

# CATSKILL

C R A F T S M E N , I N C .

## Assembly Instructions Model 15218

### *Deep Drawer Island*



#### **GENERAL:**

1. You have purchased model 15218.
2. Should you need assistance or need to replace a damaged or missing part simply give us a call M-F at 607-652-7321 from 7:30 am - 4:30 pm Eastern and we'll send you the prepaid part via UPS usually that same day! You may also email us: [info@catskillcraftsmen.com](mailto:info@catskillcraftsmen.com).
3. Read the assembly instructions and the enclosed brochure before beginning assembly. Assembly is easy if you read and follow the instructions step by step. See our website for instructions and assembly videos: [www.catskillcraftsmen.com](http://www.catskillcraftsmen.com).
4. The only tools needed are a hammer, medium and small Phillips head screwdrivers and a pencil. A power screwdriver will speed assembly, but is not required.
5. Glides are sometimes pre-packed with screws. These are not used.
6. Instructions (left/right, top/bottom) are given as you face an assembled unit.

# Parts List Model 15218

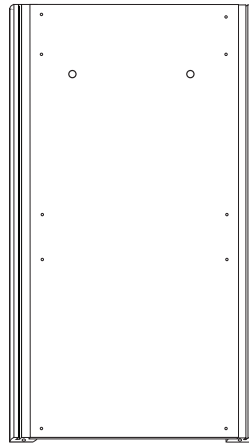
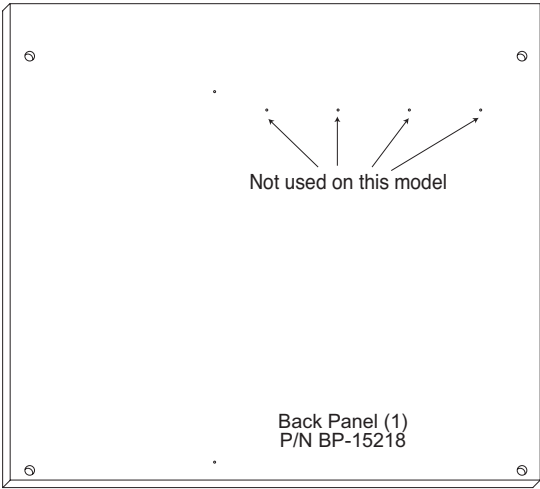

Left Side Panel (1)  
P/N LFT/SP/HDL-15218/63037

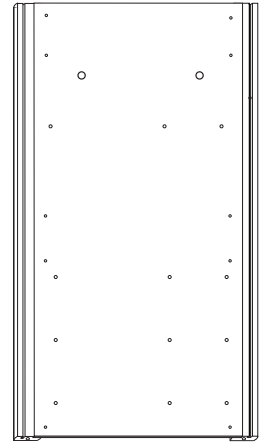

Right Side Panel (1)  
P/N RGHT/SP/HDL-15218/63037

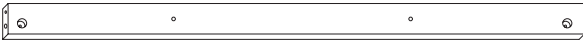

Top & Bottom Front Braces (2)  
P/N B34 1/4 / 2 1/2 /BOT-15218



Top Right Drawer Side (1)  
P/N Top DS-15218/R

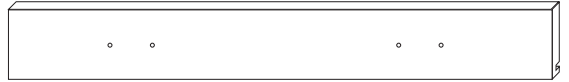

Top Drawer Front (1)  
P/N DF-15218



Top Left Drawer Side (1)  
P/N Top DS-15218/L

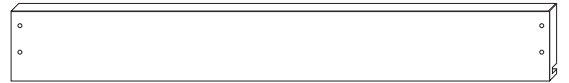

Top Drawer Back (1)  
P/N DBK-15218

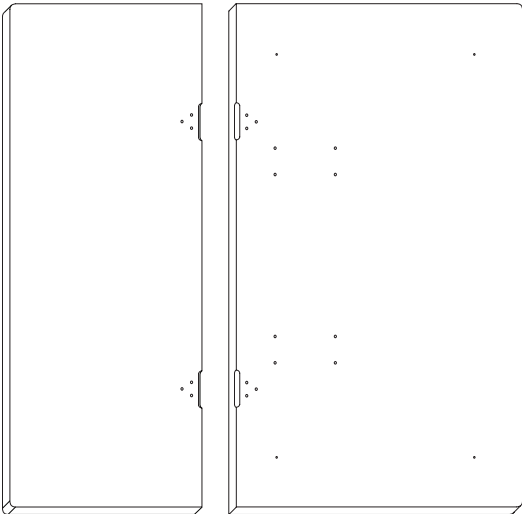

Drop Leaf (1)  
P/N DL-15218

Table Top (1)  
P/N TT-15218



Lower Left Drawer Side (2)  
P/N Low DS-15218/L



Top Drawer Bottom (1)  
P/N TDB-15218



Lower Right Drawer Side (2)  
P/N Low DS-15218/R

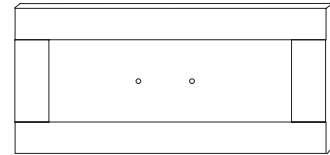

Middle Drawer Front (1)  
P/N Mid DF-15218



Lower Drawer Back (2)  
P/N Low DBK-15218

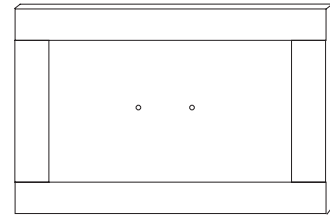

Bottom Drawer Front (1)  
P/N Bot DF-15218



Lower Drawer Bottom (2)  
P/N LBS-15218



Glide Support (2)  
P/N GLDSUP-15218

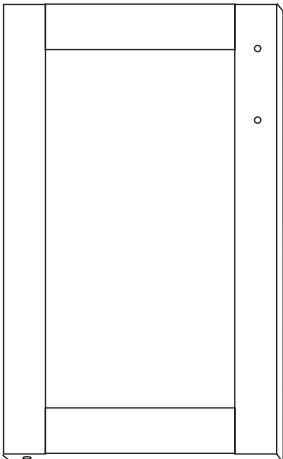

Door (1)  
P/N Dr-15218

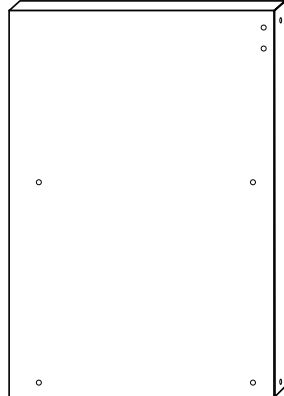

Center Divider (1)  
P/N DIV-15218  
Left Side View

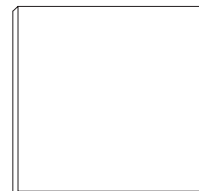

Bottom Shelf (1)  
P/N BS-15218

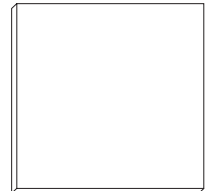

Middle Shelf (1)  
P/N MS-15218

# Hardware List Model 15218

To ease assembly, sort and count the hardware before getting started.

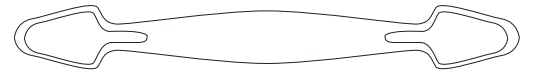

Nickel Handle (5)

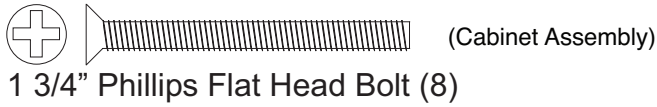

1 3/4" Phillips Flat Head Bolt (8)

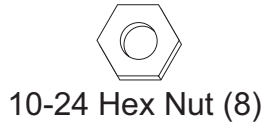

10-24 Hex Nut (8)

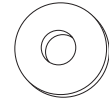

3/16" Flat Washer (13)

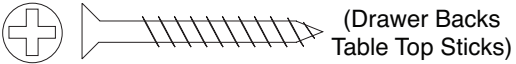

1 1/4" Phillips Flat Head #8 Screw (20)



5/8 Wooden Disk (8)

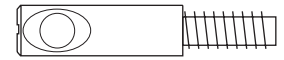

Bastion Post (10)

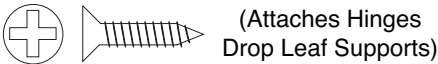

5/8" Phillips Flat Head #8 Screw (20)

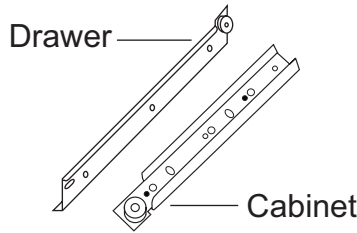

Drawer Glide (1 Set)



Bastion Set Screw (10)

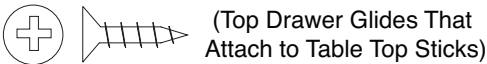

5/8" Phillips Flat Head #7 Screw (4)  
Bundled and labeled separately.

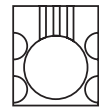

Bastion Barrel Nut (10)

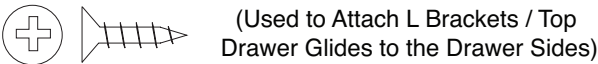

5/8" Phillips Flat Head #6 Screw (12)

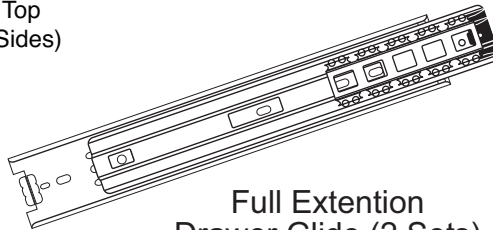

Full Extension  
Drawer Glide (2 Sets)

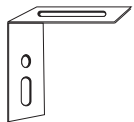

L-Bracket (4)



1" Phillips Flat Head #8 Screw (4)



Metal Middle Shelf Pin (2)



3/8" Phillips Pan Head #8 Screw (20)



Polished Nickel Towel Bar (2)



1" Truss Head Machine Screw (6)

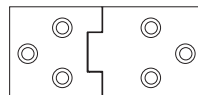

Hinge (2)

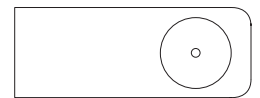

Towel Bar Post (4)



1/2" Truss Head M4x10 screw (4)

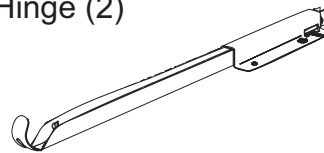

P/N Drop Leaf Support (2)

Caster Socket (4)



1 1/2" Long 3/16" DIA. Steel Pin (2)



1" Long 3/16" DIA. Steel Pin (8)



3/4" Long 3/16" DIA. Steel Pin (8)

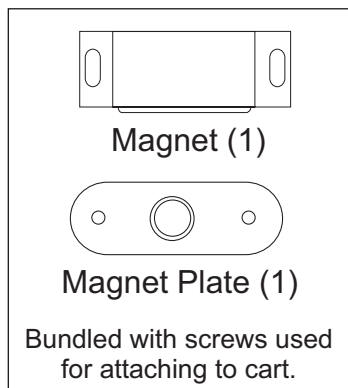

Magnet (1)



Magnet Plate (1)

Bundled with screws used  
for attaching to cart.

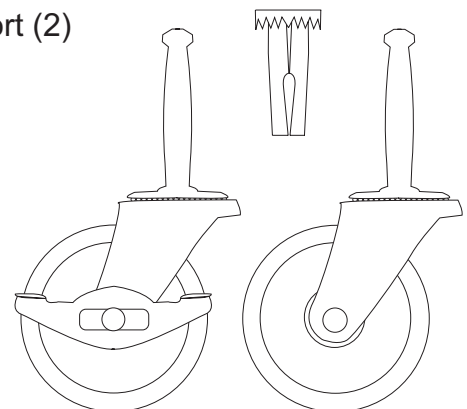

Locking Wheel  
Casters (2)

Wheel  
Casters (2)

# STEP 1A -

## Important - Please Read These Instructions Carefully!

### Attach Glides to Side Panels

1. Remove the drawer side section of the glide by pushing the black lever down and sliding the steel inner glide section all the way out of the glide assembly. Set this inner section aside as it will be used later on the lower drawer sides.

2. Next, identify the holes to be used for attaching each glide to the side panel. **IMPORTANT** as shown below, the full extension glides are only attached to the right side panel and to the center divider as shown in Step 6.

Attach glides using 3/8" #6 pan head screws. In step 9 you will loosen these screws to slide the glides flush with the back panel once it is attached.

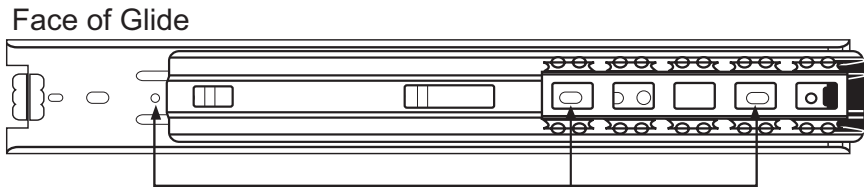
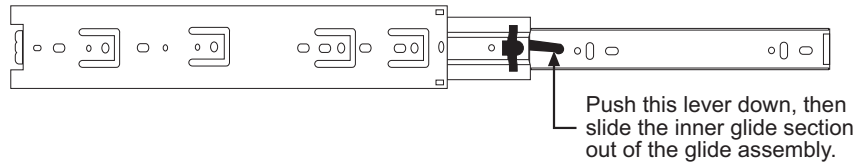

Use these three (3) holes to attach the glide to the side panel.

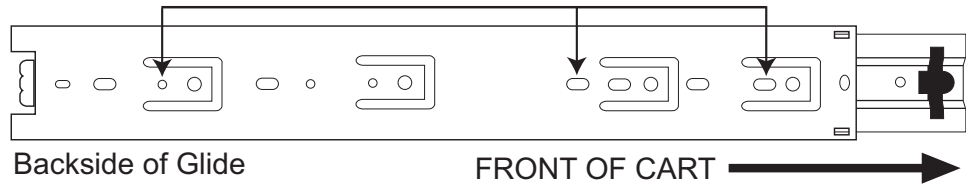

This edge will attach to back panel in the next step.

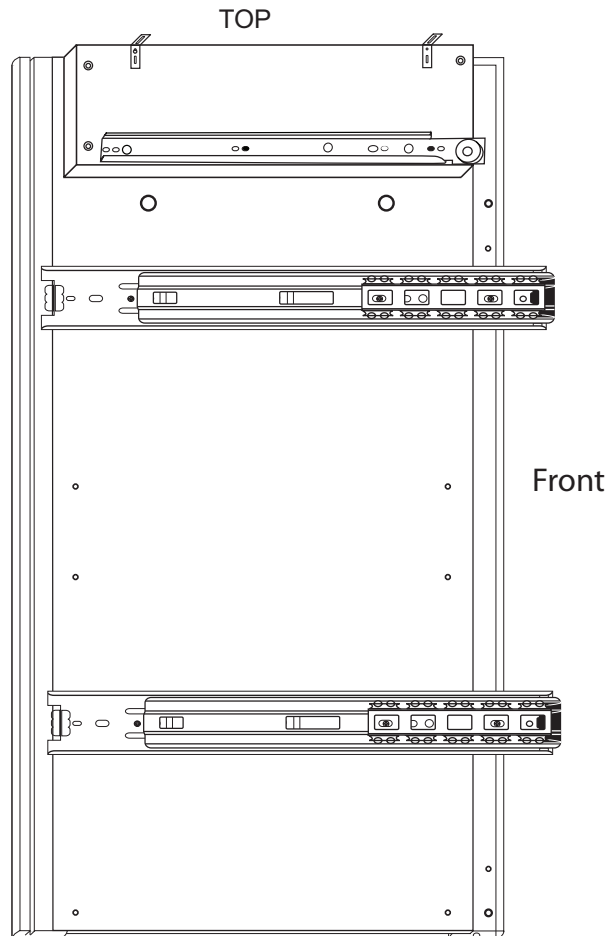

# STEP 1B

IMPORTANT - There is a right and a left side panel. Lay them out as shown below. Pay close attention to the glides so that they are properly positioned when attaching to the side panels. Review Step 1A for specific instructions on the full extension glides.

Attach L Brackets with 5/8" #6 screws. Use the small round hole, not the slot.

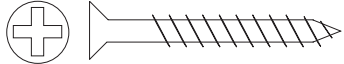
 8 Used in this step  
1-1/4" Phillips Flat Head #8 Screw

 4 Used in this step  
5/8" Phillips Flat Head #6 Screw

 4 Used in this step  
5/8" Phillips Flat Head #7 Screw

 6 Used in this step  
3/8" Phillips Pan Head #8 Screw

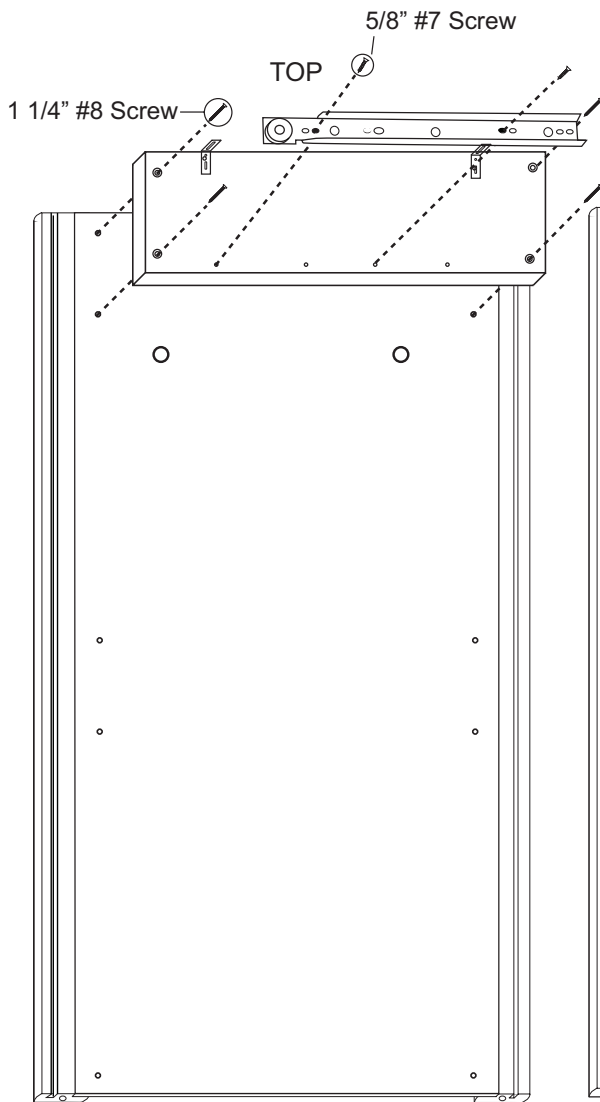

Left Side Panel

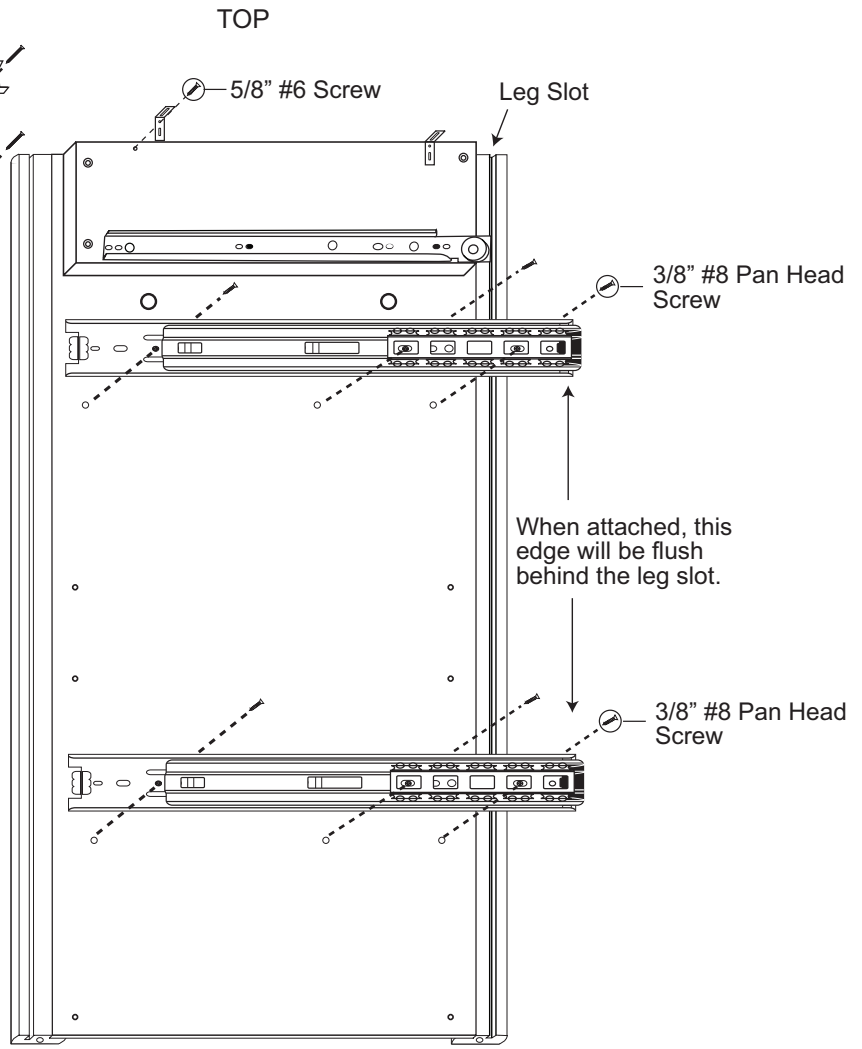

Right Side Panel

PLEASE NOTE - Some pieces are interchangeable with other units we manufacture, and thus some pilot holes may not be used. It is important to note the proper holes required for assembly in each step.

# TIPS ON HOW THE BASTION FASTENING SYSTEM WORKS

1. The Bastion fastening system consists of a steel post (threaded on one end with a hole through the shaft on the other end); a Barrel Nut (cylindrical barrel-shaped with threaded open end & holes through the sides); and a Set Screw (Phillips slot on one end, pointed on the other)

2. To attach Posts: A) Dip threads of Post in vegetable oil. B) Align threaded end of Post with hole in wood, tap on slotted end with hard hammer until threads enter, then tighten down using a flat head screw driver or the provided allen wrench (See the Illus. Bas. 3 for alternate seating methods). **DO NOT TRY TO HAMMER THE POST ALL THE WAY IN AS IT WILL STRIP THE POST HOLE.** C) When solid shaft of Post hits wood, back out approximately 1/2 turn until the hole in the posts is properly aligned as per step by step directions. For example: the holes in the posts on the inside of the drawer front will be parallel with the long length of the drawer front when properly seated.

3. A) Place a Barrel Nut into the nut access hole, so that the threads in the nut face out. The small notches on either side of the nut opening, indicate the location of the holes through the sides of the nut. B) Insert the posts through the end of the braces (or drawer sides); through the holes in the sides of the nut. When properly aligned, you will see the hole in the post inside the barrel nut. Post hole should be slightly off-center toward the wood.

4. Insert the Set Screw into the threaded end of the nut and tighten down. The tip of the Set Screw will seek the center of the hole in the Post as it is tightened down, forcing the Nut toward the main shaft of the Post. This is what tightens the wooden parts together. Set screws should thread easily – **DON'T CROSS THREAD!** If Set Screw doesn't thread easily, check position of the hole in Post.

5. If the wooden parts are not tight against each other, the Post needs to be screwed a half turn at a time until wood joints are tight.

Illustration Bas. 1

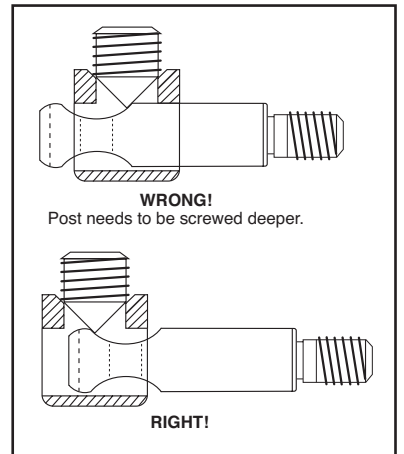

Step 1

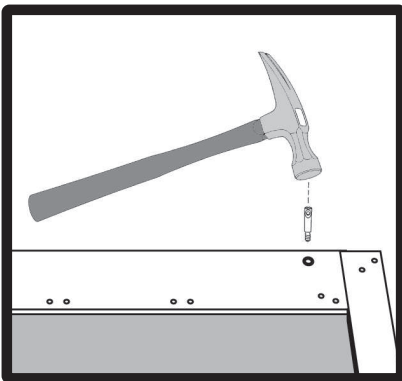
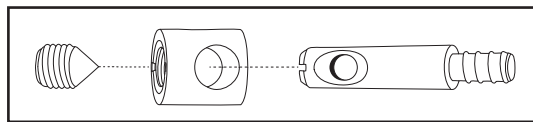
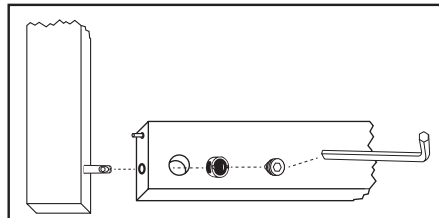

Illustration Bas. 2



Step 2



Allen Wrench Provided

Illustration Bas. 3

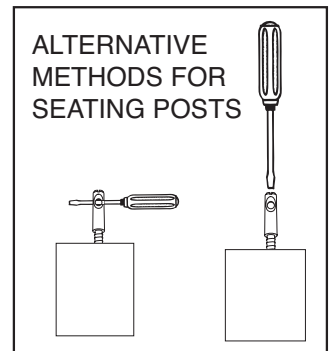

See video on our website!

If you have any questions regarding assembly or missing or damaged parts, call our customer support number:

607-652-7321 or 888-732-7321.

Customer Support Hours are 8am-5pm Mon. - Fri. Eastern Time zone.

## STEP 2

A. Attach the Top Drawer Back to the Drawer Sides with four 1 1/4" #8 screws. There are left and right sides. Make sure the slots that run the length of the Sides are aligned with the slot in the Drawer Back to accept the Drawer Bottom.

B. Slide in Drawer Bottom, best side up, to inside of drawer.

C. Take the 2 bastion posts, align the threaded end of the posts with the post holes located near the ends of the inside of the Drawer Front. Tighten posts down until the solid shaft of the posts hits the wood. Back post out one full turn until the hole/screwdriver slot in end of post is parallel and in direct line with the long edges of the Drawer Front.

D. Insert the barrel nuts into the nut access holes on the inside of the Drawer Sides with the threaded ends of the nuts facing out. Take the Drawer Front and carefully insert the posts into the ends of the Drawer Sides, through the sides of the nuts until seated. Push nut snug up against the wood in the nut access hole toward the inside of Drawer Front. Hole should be slightly off-center toward the Drawer Front. Insert the set screw and tighten down. The ends of the sides should be tight against the inside Drawer Front.

E. Attach the drawer handles with 1" Truss head machine screws.

F. Attach the drawer glides (left and right) to the Drawer Sides using two 5/8" #6 screws per side (packaged separately). Wheels go toward Drawer Back and are up. The end with no wheels should touch the Drawer Front.

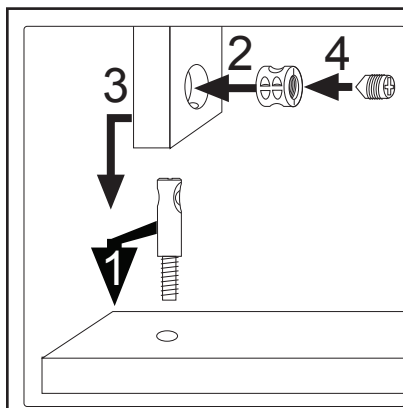
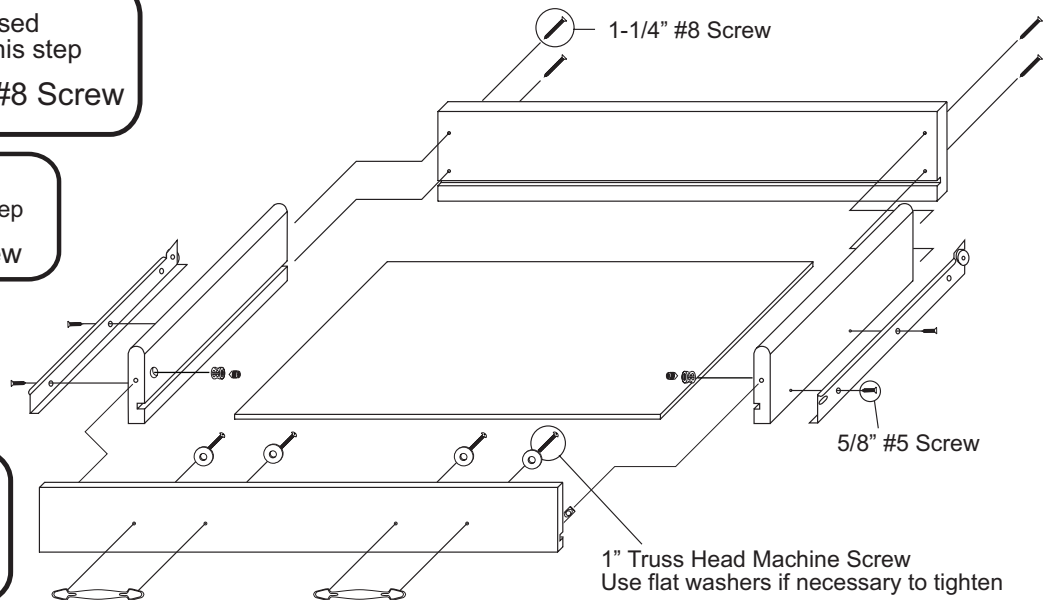
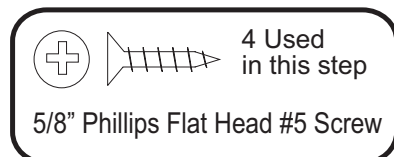
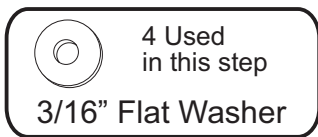
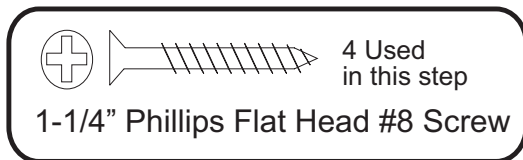

### BASTION ASSEMBLY INSTRUCTIONS

**DO NOT USE POWER SCREW DRIVER FOR THIS STEP.  
USE HAND SCREW DRIVER ONLY.**

1. Screw Bastion post into drawer front. Screw until all threads are hidden, then back out a full turn such that the hole in the post will face left to right.
2. Place the barrel nut into the side brace hole.
3. Slide the side brace onto the post such that the post also slides into the barrel nut.
4. Screw the set screw into place, tightening such that the side brace and drawer front pull together tightly.



# STEP 3

Perform a similar drawer assembly as Step 2 for the lower drawers.

- A. Using 1-1/4" #8 screws, attach the drawer back to the drawer sides as shown below.
- B. Slide the drawer bottom into the slots.
- C. Insert Bastion Posts into the drawer front and tighten into position.
- D. Insert Barrel Nuts into the holes on the drawer sides, and slide the drawer front into place. Tighten with the set screws. Use hand screwdriver or hex wrench.
- E. Attach the full extension glides to the drawer sides. See step 1B to locate the correct part of the glide for this step.
- F. Using 1/2" Truss head screws with two washers each, attach the handle to the drawer front.

FOR TIPS ON HOW THE BASTION SYSTEM WORKS SEE LAST PAGE!

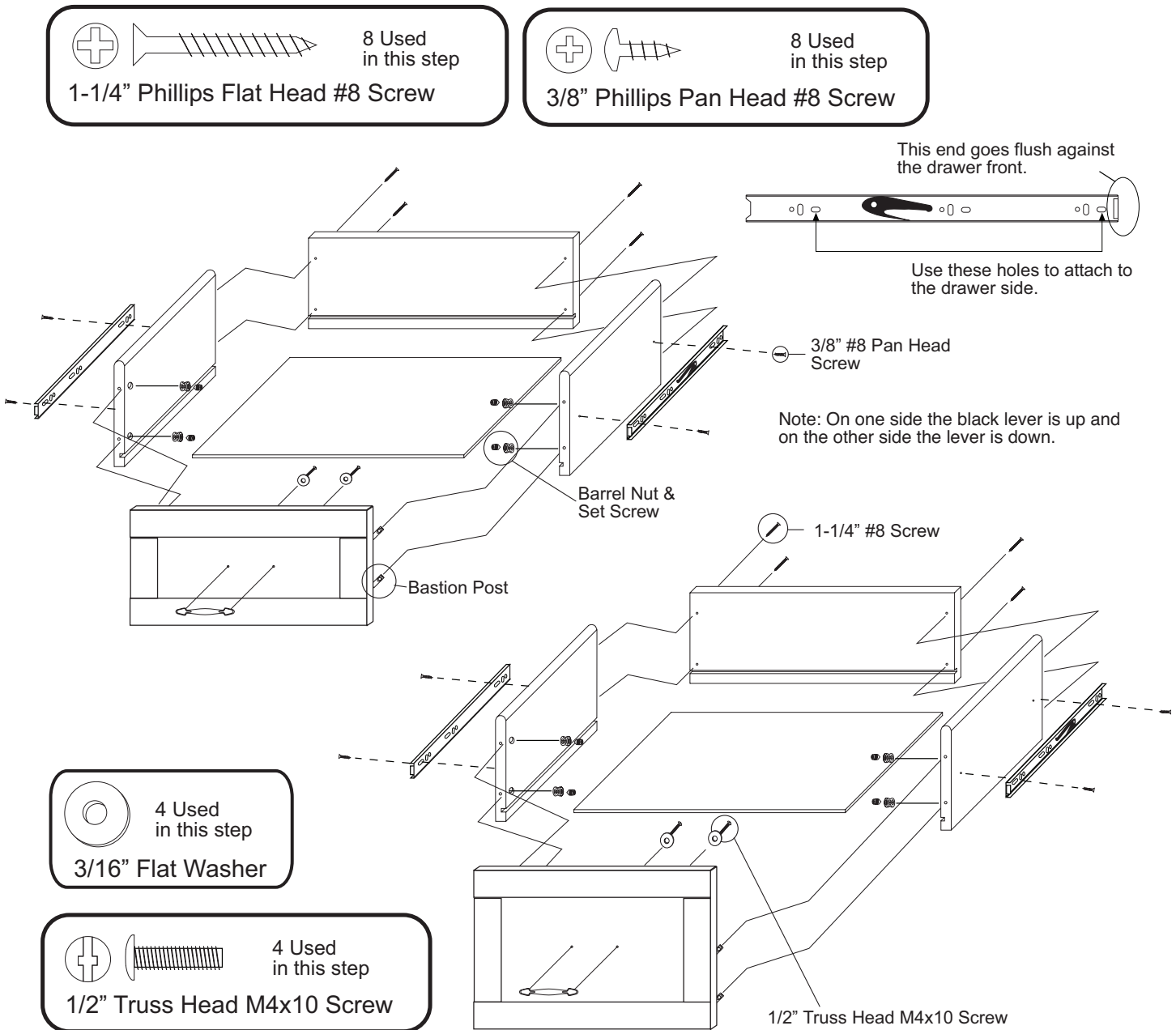



## STEP 4

A. Tap/insert ONE 1 1/2" pin into each end of the door. DON'T OVERDRIVE PINS! Pins should stick up about 1/2" when seated. Ok if loose.

B. Attach the magnet plate (may be stuck to magnet in the hardware pack!) with a 1/2" #4 screw to the top of the door. Bumps go toward the wood, and the plate should be vertical.

C. Attach door handle with 1" truss head machine screws. Use washers if necessary to tighten.

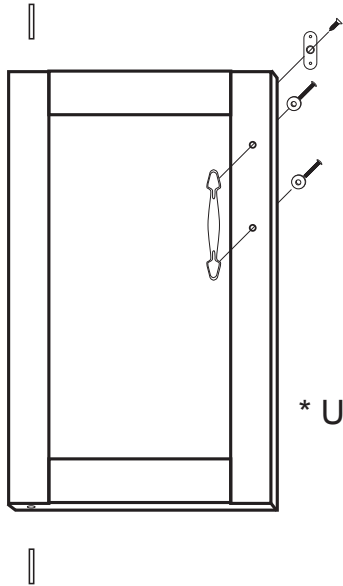

2 Used  
in this step

1" Truss Head Machine Screw

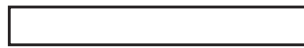

2 Used  
in this step

1 1/2" Long 3/16" DIA. Steel Pin

\* Use flat washers to tighten handle if necessary.

## STEP 5

A. Take the 2 front braces and tap/insert one 3/4" steel pin into each end of both braces until seated. About 3/8" will stick out when seated. OK if loose.

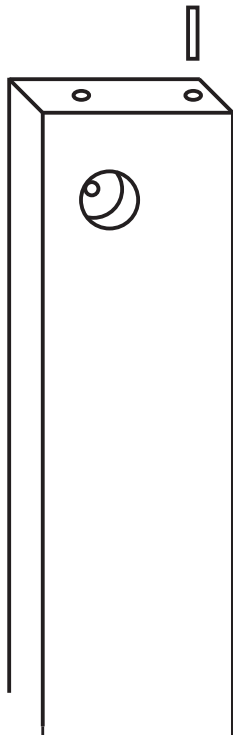

4 Used  
in this step

3/4" Long 3/16" DIA. Steel Pin

## STEP 6

- A. Tap/insert 3/4" pin into each long edge of the center divider. DON'T OVERDRIVE PINS! Pins should stick up about 1/4" when seated. Ok if loose.
- B. Attach the magnet with 1/2" #4 screws to the top of the door.
- C. Attach full extension glides to the center divider as shown. Note that the glides should slide out towards the same edge with the attached magnet.
- D. Tap 1" steel pins into the left side of the center divider to be used as shelf supports in a later step.

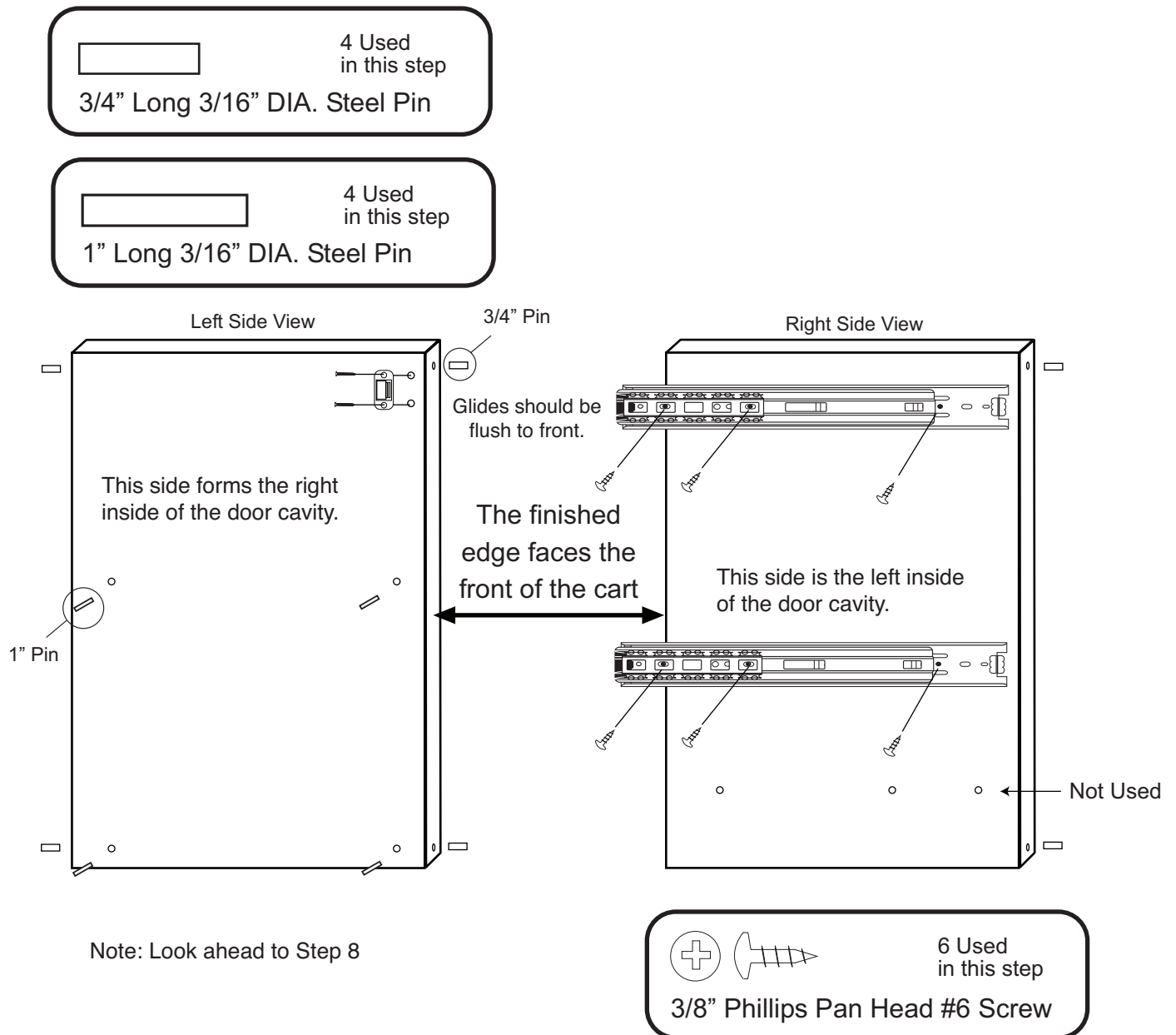

## STEP 7

A. Lay Back Panel flat on a smooth surface with holes up.

B. Attach Side Panels with 1 3/4" machine screws (bolts) and hex nuts. After inserting bolts(s) thru the holes in the Side Panels, thru the holes in the long edges of the Back Panel, place a hex nut on the tip of your finger, align nut with bolt and tighten.

C. Look ahead to step 8 which shows side panels attached to back panel.

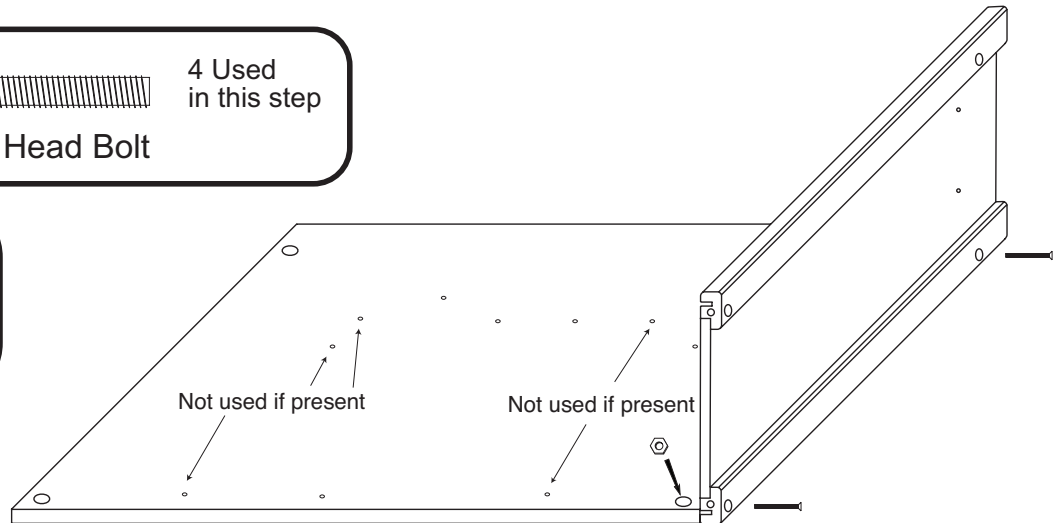
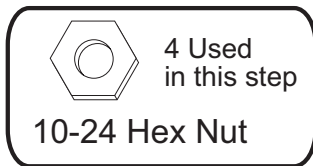
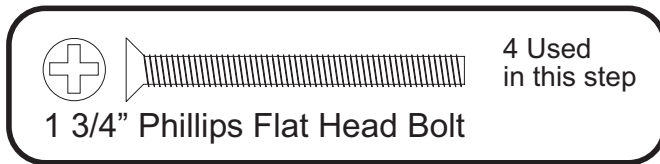

## STEP 8

A. Upright the unit. Place the center divider pins into the holes in the back panel.

B. Take the Bottom Front Brace and insert the pin in the right end of the brace into the slot in the top of the right front leg and slide down as in the illustration. The pin in the left end of the brace will be outside the slot at this time. Loosely secure the right side of the brace with 1 3/4 in. machine screw/nut. Align the bottom pin in the divider with the hole (closest to the left side) on the inside of the bottom front brace. Spread the left side panel until the pin in the left end of the brace can enter the slot and secure brace with 1 3/4 in. machine screw/nut. Tighten right side bolt/nut.

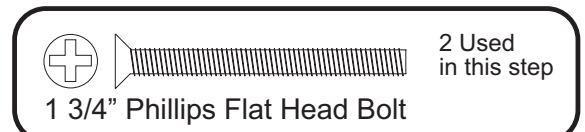
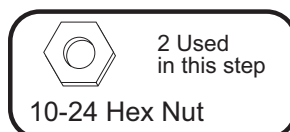
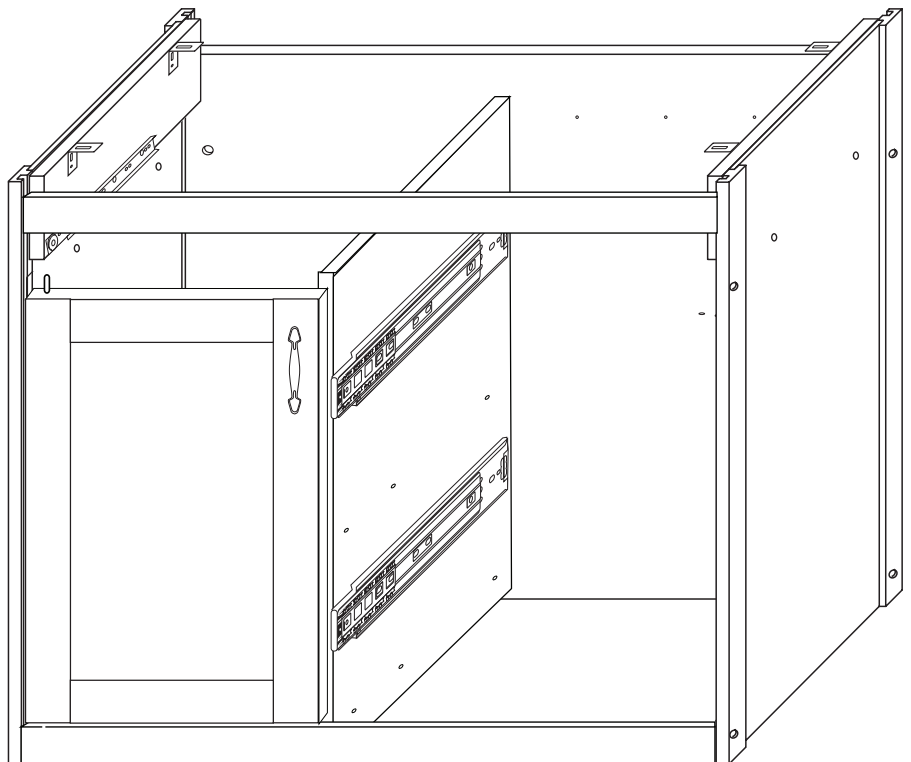

## STEP 9

A. Fit a washer onto the bottom door pin and slide the pin into the bottom front brace.

B. Loosely secure the left side of the Top Front Brace with a 1 3/4" machine screw/nut after inserting the top door pin into the hole in the bottom edge of the brace. With the right side of the brace/pin still outside the opposite leg slot, insert the top pin in the divider into the hole on the inside face of the brace. Secure right side of brace by spreading the (top) right side and inserting the brace pin into the slot. Secure brace with 1 3/4" machine screw/nut.

C. Tap two Metal Shelf Pins into Side Panel as in illustration 9B. These will hold the shelves.

**IMPORTANT!** - To guarantee proper positioning, loosen the screws holding in the full extension drawer glides, and shift the glides back as far as possible. Retighten the screws.

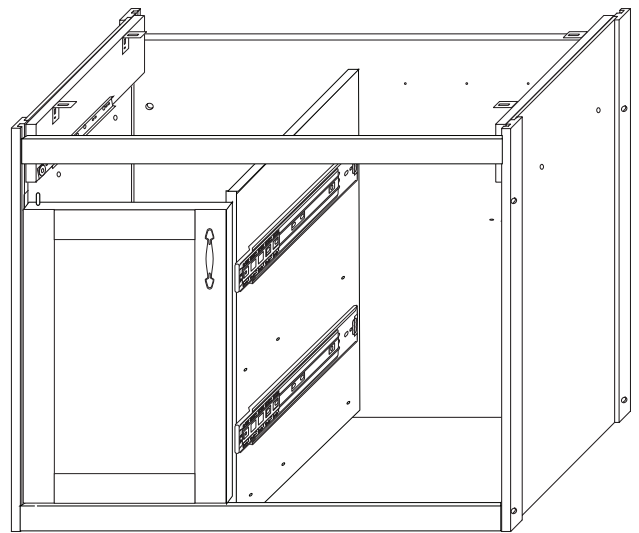
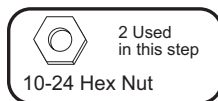
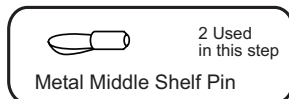

ILLUSTRATION 9A

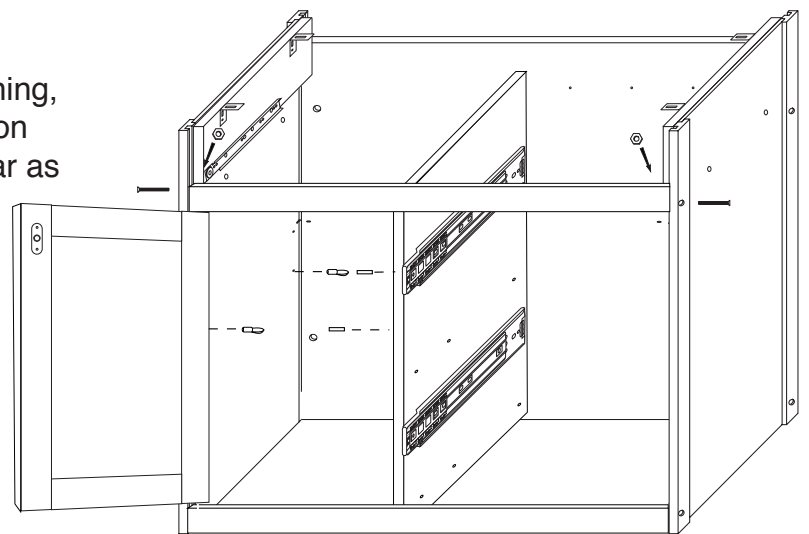

ILLUSTRATION 9B

## STEP 10

Invert unit, or lay the unit on its back to insert the wheels. Have a friend help with this step as the unit can be heavy and awkward to move.

A. Insert and tap caster sockets with hammer until the teeth grab the wood. **DON'T POUND SOCKET FLAT OR CASTER SHAFT WILL NOT ENTER.**

B. Insert casters and seat by pushing straight downward with heel of your hand, or tap into place with a hammer. Don't be afraid to give them a good downward whack on the solid metal part of the caster!

C. Locking wheels usually go on front.

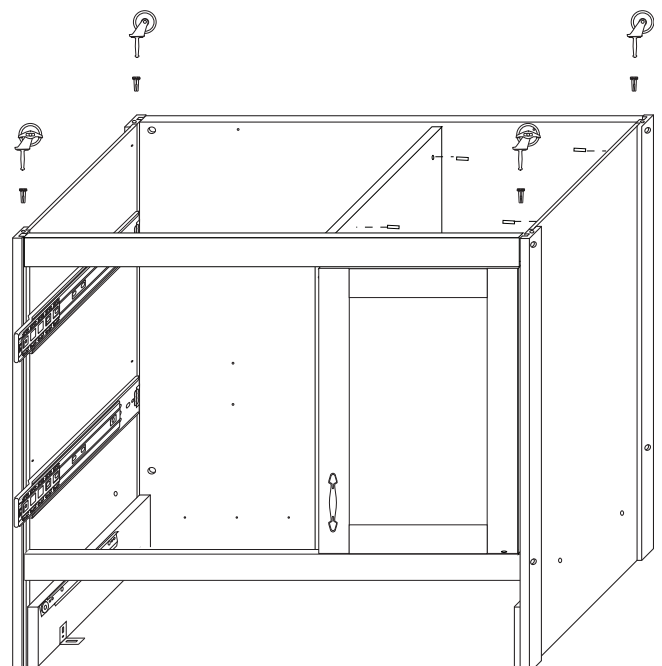

## STEP 11

A. Upright unit.

B. Attach Towel Bars to the Side Panels with 1" #8 screws from inside each Side Panel. Place a washer over the screws.

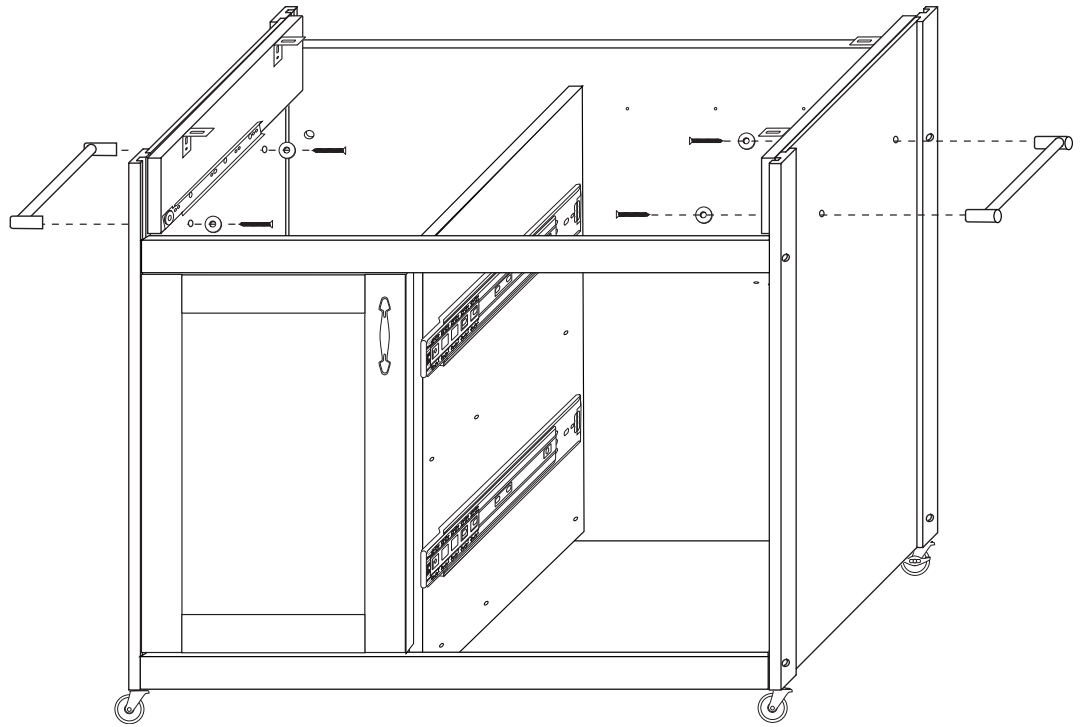

## STEP 12

A. Assemble top by placing the top and the drop leaf upside down on a smooth flat surface. Install hinges using 5/8" #8 screws. The longer part of the hinge goes on the drop leaf with the short part on the cart top. Fasten the drop leaf supports using 5/8" #8 screws. Attach Drop Leaf Supports with 5/8" #8 screws. See illustration 12A.

B. Make a large ( X ) mark over each of the 4 pilot holes in the bottom. Make marks about 1/2-1" long. These marks will help you align the cabinet with the pilot holes in the bottom of the Top.

C. Place the Cart Top on the cabinet. Open the outside doors. Maneuver the Cart Top so that the ( X ) marks/pilot holes in the bottom of the Top align with the slots in the "L" brackets. Secure top to "L" brackets with 5/8" #6 screws.

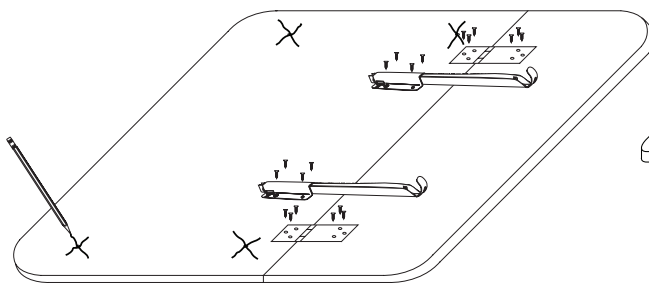
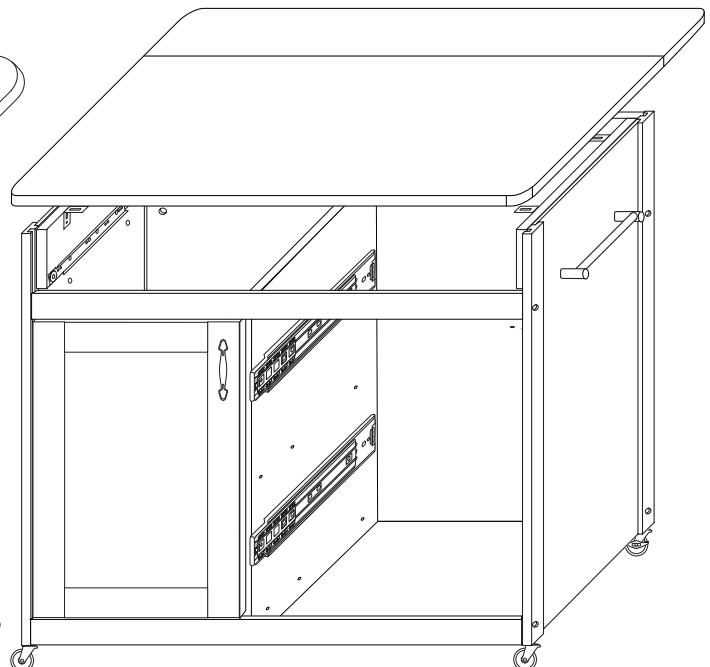

ILLUSTRATION 12A

Note: If you have problems using this method, get help and invert the table top on a smooth flat surface. Invert the cabinet onto the table top and align pilot holes with L Bracket and secure using 5/8" #6 screws.

ILLUSTRATION 12B



## STEP 13

Slide the lower drawers into place. In initially seating the glides the drawer will stop about 2/3 of the way in when the glides hit the plastic tabs. At this point just shove the drawer in with a little force. Once the glides are properly seated, the drawers should pull out and slide in with ease.

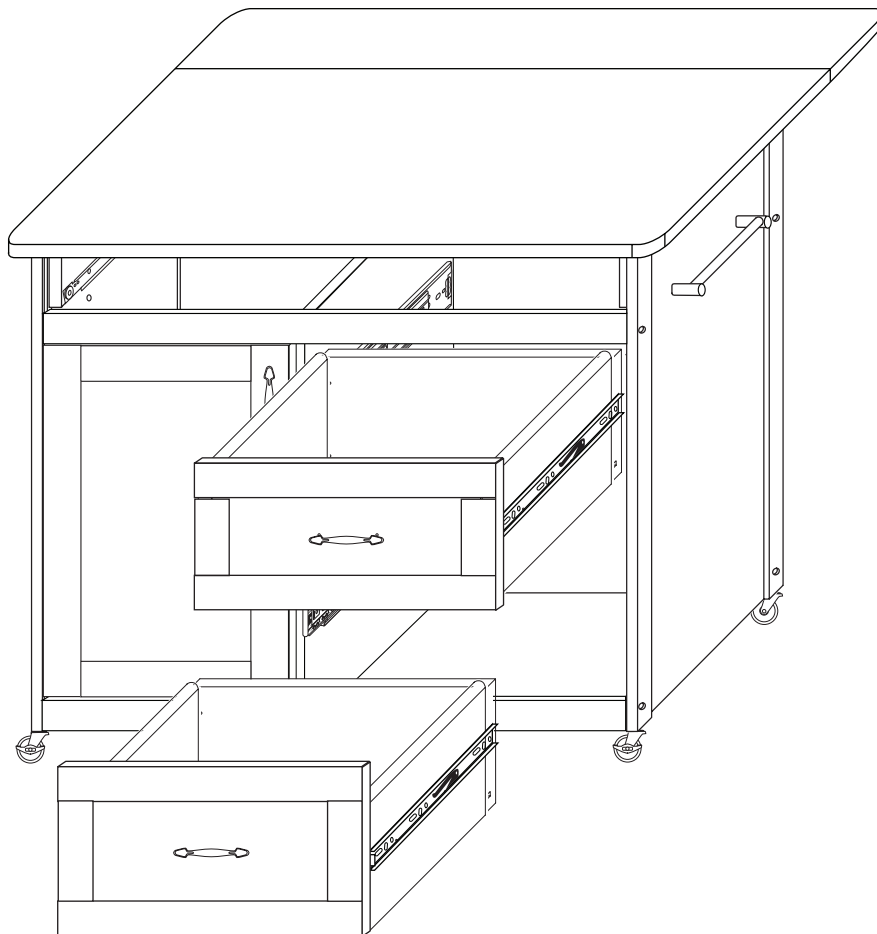

## STEP 14

A. Tilt the bottom shelf and set down onto the pins.

B. Fit the middle shelf into the cart and rest it on the pins. Edge banding should face out.

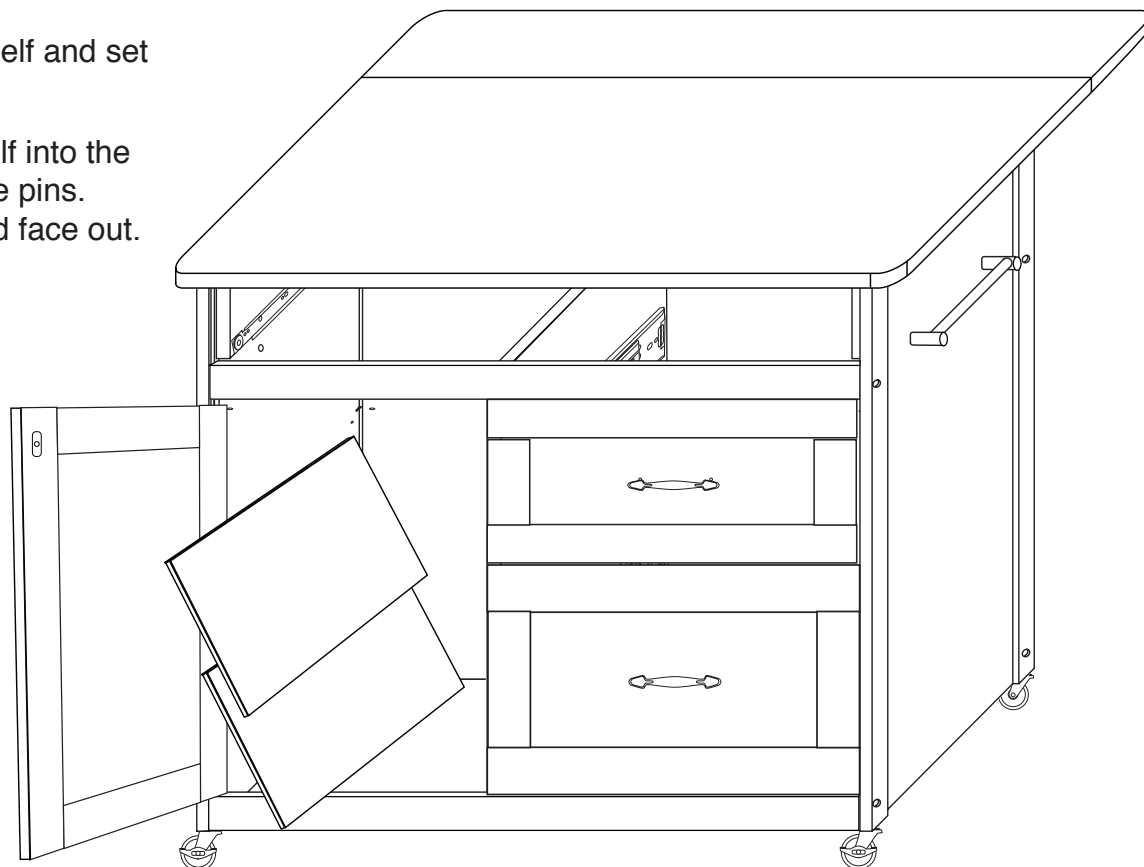

## STEP 15

A. Slide the top drawer into the front of the cart.

B. Retighten all 1 3/4 in. machine screws and nuts. Tap in the 5/8 wooden plugs into the holes on the legs.

C. Illustration 15B shows completed 1521.

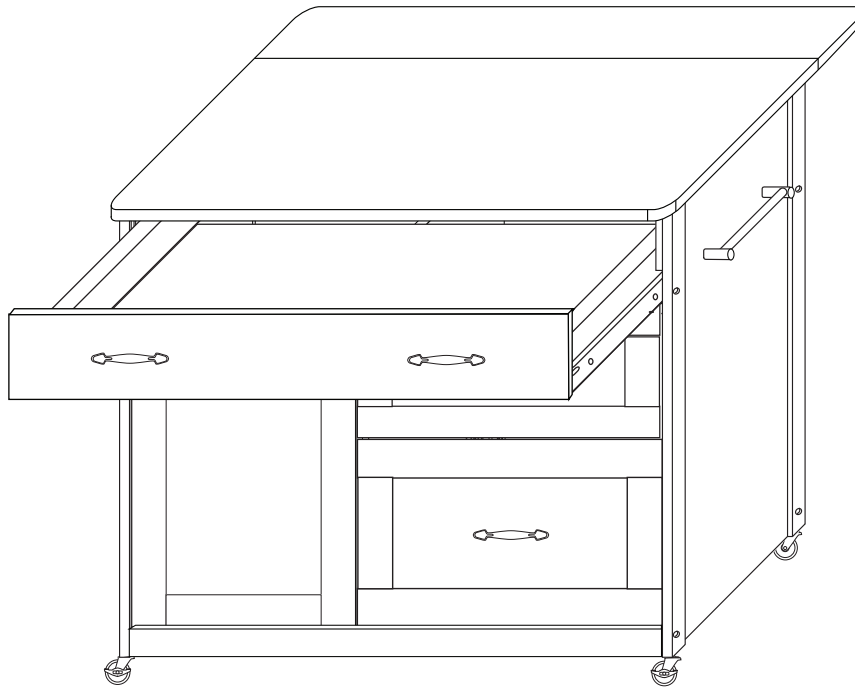

**ILLUSTRATION 15A**

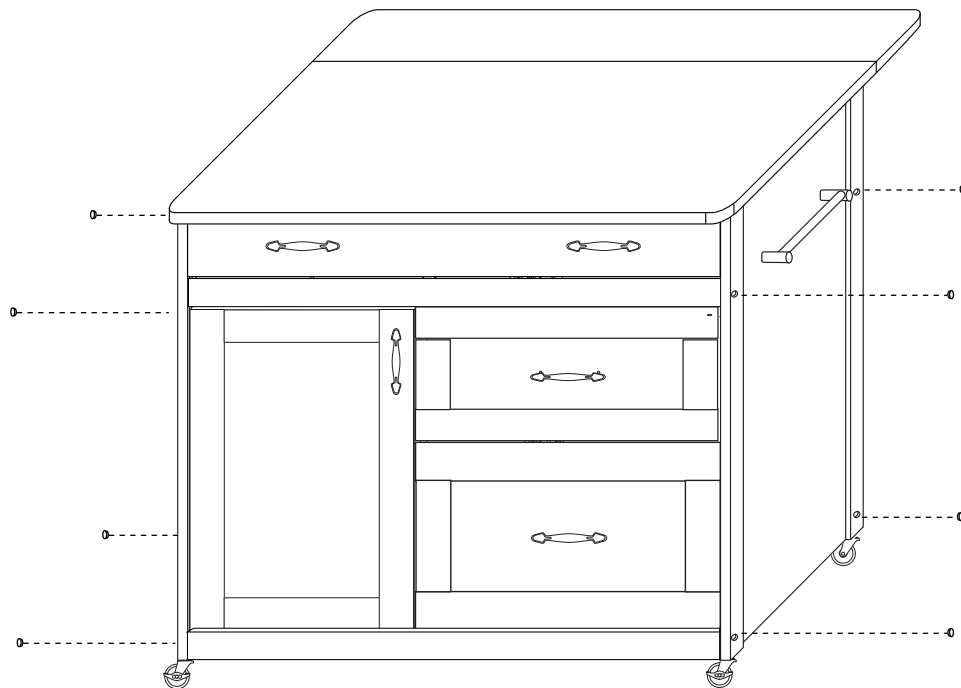

**ILLUSTRATION 15B**





For continued beauty and long life of your Catskill Craftsmen cart, we recommend Catskill Craftsmen's Butcher Block Oil.

Our Butcher Block Oil is available directly from Catskill Craftsmen's factory. For one eight ounce (8 fl. oz.) bottle, which is sufficient for two applications, simply send \$6.95 along with the completed coupon to the address below. Visit us online at [www.catskillcraftsmen.com](http://www.catskillcraftsmen.com) to browse our assortment of butcher block care products. Visa and Mastercard are accepted online.



Catskill Craftsmen, Inc.  
15 West End Ave.  
Stamford, NY 12167-1296



### BUTCHER BLOCK OIL COUPON

Please send me \_\_\_\_\_ # of bottle(s) of the Catskill Craftsmen Butcher Block Oil at \$6.95 per bottle. My check or money order is enclosed for a total of \$\_\_\_\_\_.

Item code: 15218

Name \_\_\_\_\_

Address \_\_\_\_\_

City \_\_\_\_\_

State \_\_\_\_\_ Zip \_\_\_\_\_

Please make checks payable to Catskill Craftsmen Inc. 15 West End Ave., Stamford, NY 12167-1296