

INSTALLATION INSTRUCTIONS

Solaia Sentry

HW+

System Manager



Keep these instructions with the boiler at all times for
future reference

BOYERTOWN FURNACE CO.

PO Box 100

BOYERTOWN, PA 19512

1-610-369-1450

www.boyertownfurnace.com

Be Aware of Hazard Definitions

Danger

Denotes presence of a hazard which, if ignored, will result in severe personal injury, death or property damage

Warning

Denotes presence of a hazard which, if ignored could result in severe personal injury, death or substantial property damage.

Caution

Denotes the presence of a hazard, which if ignored, could result in minor personal injury or property damage

Notice

Intended to bring attention to information, but not related to personal injury or property damage.

Danger

This equipment must be installed, adjusted, serviced and started only by a qualified service agency – an individual or agency, licensed and experienced with all codes and ordinances, and who is responsible for the installation and adjustment of the equipment. The installation must comply with all local codes and ordinances and with the latest revision of the National Fire Protection Standard for Oil Burning Equipment, NFPA 31.

Read all instructions before proceeding. Follow all instructions completely. Failure to follow these instructions could result in equipment malfunction causing severe personal injury, death or substantial property damage.

Do not alter this kit or the boiler in any way. The manufacturer will not be liable for any damage resulting from changes made in the field to the boiler or its components or from improper installation. Failure to comply could result in severe personal injury, death, or substantial property damage.

Your oil fired boiler is designed to burn No. 1 and No. 2 heating oil only. Never use gasoline or a mixture of gasoline and oil.

Do not store gasoline or other flammable vapors and liquids in the vicinity of this or any other appliance.

The area around the boiler should be kept free and clear of combustible materials.

Never burn garbage or refuse in your boiler.

Never try to ignite oil by tossing burning papers or other material into your boiler.

Do not attempt to start the burner when excess oil has accumulated or the boiler is full of vapors.

Do not operate boiler if the heat exchanger is damaged.

Do not jumper, attempt to bypass or override any of the safety limit controls.

Do not use this boiler if any part has been under water. Immediately call a qualified service technician to inspect the boiler and replace any part of the boiler, control system or burner that has been under water.

All installations must conform to the requirements of the authority having jurisdiction. Such applicable requirements take precedence over the general instructions of this manual.

Where required by the authority having jurisdiction, the installation must conform to the American Society of Mechanical Engineers Safety Code for Controls and Safety Devices for Automatically Fired Boilers, ANSI/ASME CSD-1.

Notice

Concealed Damage- If you discover damage to the burner, boiler or controls during unpacking, notify the carrier at once and file the appropriate claim. When calling or writing about the boiler please have the following information available: The boiler model number and serial number.

Table of Contents

Operational Theory.....	4
Installing the Sentry to the Boiler.....	5
Aquastat Installation.....	6
Primary Water Sensor Installation.....	7
Domestic Water Sensor Installation.....	7
Wiring.....	8
System Check Out.....	10
Control Circuit Safety Checks.....	10
Trouble Shooting.....	11
HW+ Programming.....	12
HW+ Trouble Shooting.....	14

Operational Theory

The Solaia Sentry integrates the HW+ control allowing the burner firing pattern to accurately match the boiler output of the homes heat load.

The boiler and your heating systems are designed to ensure comfort at outdoor temperatures well below the average winter temperatures. At any temperature warmer than the coldest design temperature, the boiler is able to provide more heat than the home requires. The result is that the burner cycles on and off many times per hour to keep the home from overheating. This repeated on/off cycling is a very inefficient way for the boiler system to operate.

The HW+ uses a single temperature sensor attached to the boiler supply pipe to measure both heat load and boiler water temperature. Every time the burner shuts off the supply mounted sensor takes 3 readings per second and transmits them back to the HW+. The HW+ then determines the heat load by analyzing the temperature drop off rate during the burner off cycle.

After determining the heat load, the HW+ uses a patented algorithm to determine the minimum boiler water temperature needed to maintain comfort at the measured heat load. Energy savings which are derived from maintaining the optimal boiler temperature include reduced average flue gas temperatures, reduced off cycle flue losses, reduced distribution losses, reduced pre/post purge losses and improved burner life.

There has been substantial testing done to validate the energy savings by Brookhaven National Laboratory and Atlantic Testing Laboratory. Their test results show burner run time is reduced by 10% – 20 % and the number of burner on/off cycles is reduced by 30%.

After installation, setting the switch on the controller to the 'ON' position activates the control. The LCD display indicates the various 'modes' of the device, sensed temperatures, and percent savings.:

The additional three status lights on the Solaia Sentry indicate that the low water cut off is enabled and functioning properly, that a call for heat has been established and that the burner has been energized. See figure below for the location of lights and switches.

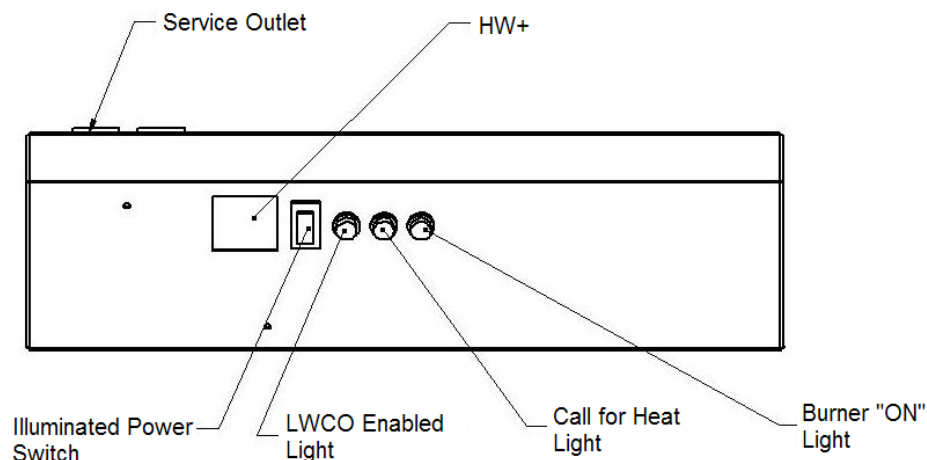

Standby Mode

The boiler is operating under its own internal operating-control, which has turned the burner off. This occurs for a period of time after the burner has shut down.

Economizer Mode

The boiler operating-control has requested the burner to come on but the controller has sensed that there is available heat which can be used without burning fuel. The burner will remain off and useful heat will be delivered from the boiler's existing supply of residual heat.

Heating Mode

The controller has released the burner to fire.

Heating / Lo Lim

The controller has released the burner to fire due to a load condition that has caused the water temperature to go below the programmed low limits. This condition may occur occasionally. If this message appears frequently, the boiler operating-control may need to be increased in 5°F(3°C) increments until the condition stops or the low limits may need to be adjusted (see Programming section)

During normal operation one of the messages will be alternated with the messages below.

Heat Temp = xxx °F

The measured value of the boiler outflow water temperature is displayed in °F.

DOM Temp = xxx °F

The measured value of the domestic hot water outflow temperature is displayed in °F (may be programmed for °C). This message will only appear if the boiler supplies domestic hot water and the optional second sensor is installed (see Sensor Section of these instructions).

EST Save = xx.x%

The calculated estimated savings of all valid burner cycles since commissioning of the controller. Note: This message will display after a minimum of 72 Hours of operation. During this time the power/fault indicator will flicker every second.

ET Hrs = xxxxx.x

Total hours of Economizer time. (maximum = 65,535.9 hours). The option to display this screen is programmable (Default = ON).

RT Hrs = xxxxx.x

Total hours of Burner run-time. (maximum = 65,535.9 hours). The option to display this screen is programmable (Default = ON).

Installing The Solaia Sentry To The Boiler

1. Lift and remove the jacket front panel.
2. Remove the two 7/8" knockouts in the jacket top panel. See figure below. Remove the lower lock nuts from the box connectors located on the Solaia Sentry.
3. Insert the box connectors through the 7/8" hole in the jacket top panel. Thread on the lock nuts to the box connector and tighten.

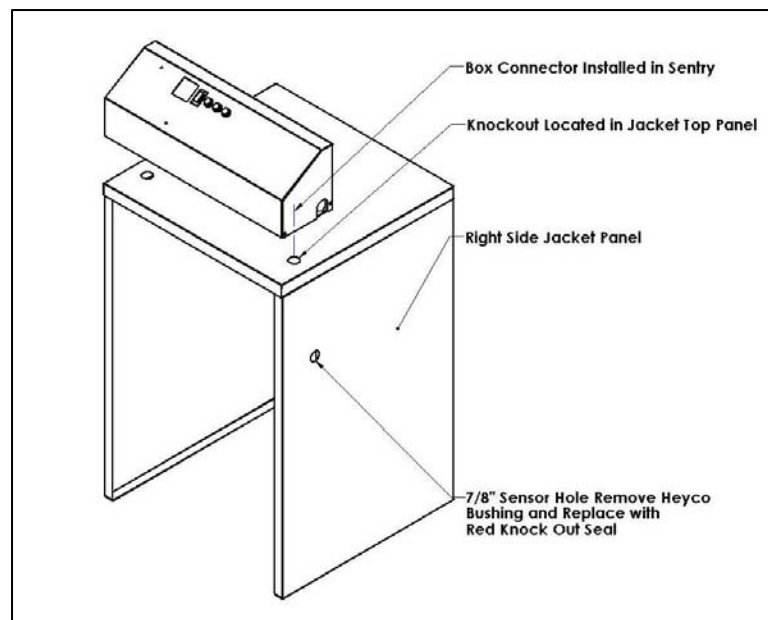

Aquastat Installation

1. Remove the aquastat from the burner box.
2. Open the Solaia Sentry box by removing only the two rear 10-32 hex washer head screws and pivoting the box top forward on the front two 10-32 hex washer heads screws. See Figure 3.
3. Install the aquastat on the base using the 10-32 hex washer head screws provided. See figure below for screw hole locations for the Honeywell Aquastat.
4. Install the Heyco bushings into the aquastat knockouts to prevent damage to the wires.
5. Remove the aquastat sensor wires which are running through the side of the jacket and feed them through the box connector of the Solaia Sentry and attach to the aquastat.

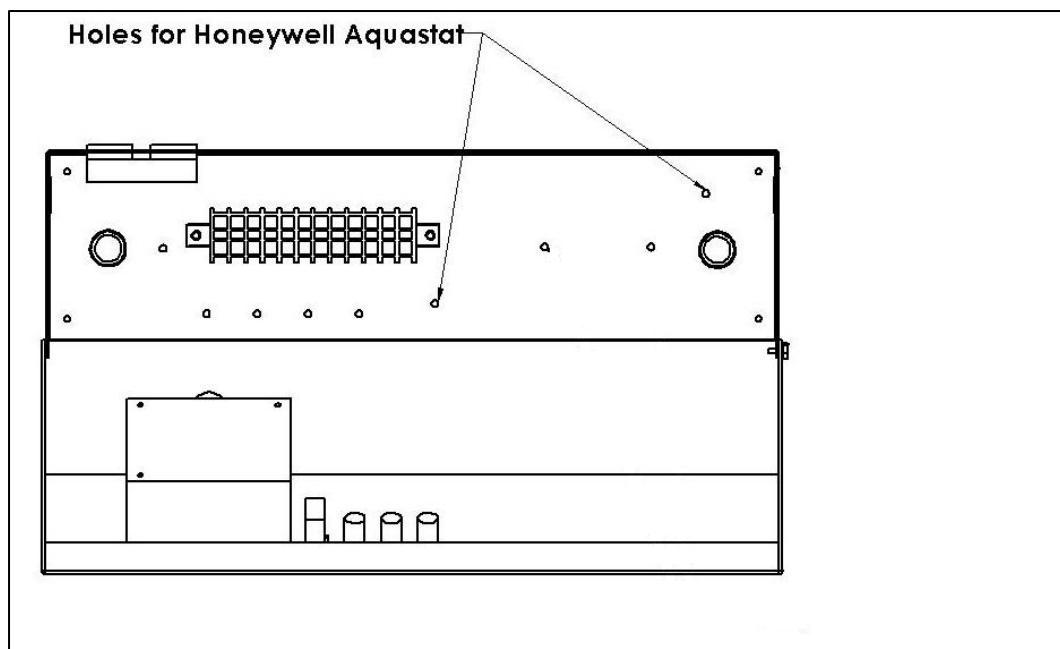
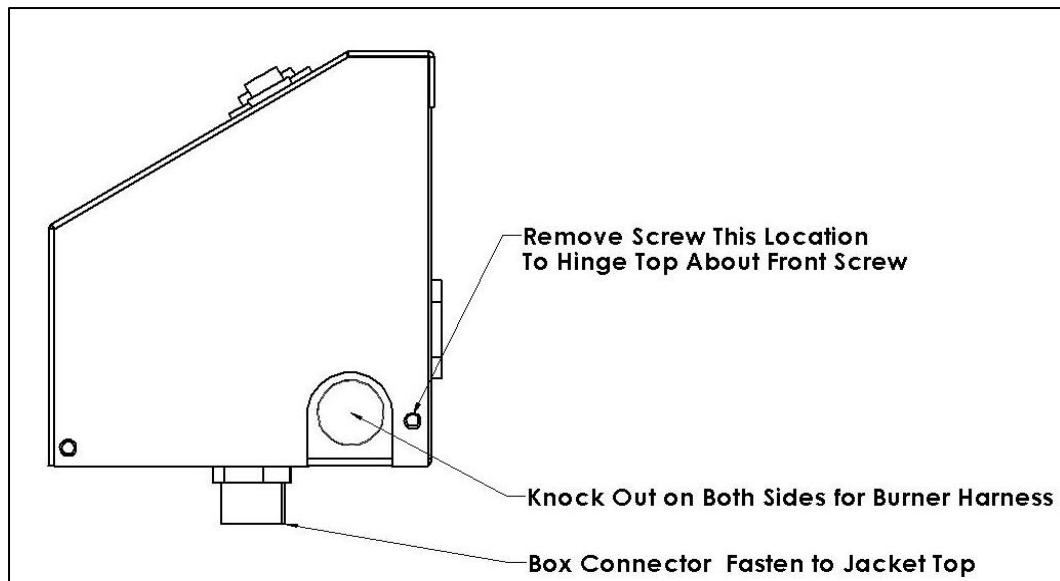

Primary Water Sensor Installation

The primary water sensor plugs into the upper jack of the HW+ module.

1. Route the sensor wire through one of the box connectors in the Solaia Sentry, under the jacket top and through the Heyco bushings which are inserted in jacket top brackets. These brackets also carry the Aquastat sensor to the back of the boiler.
2. Attach the HW+ sensor to the boiler supply pipe as close to the boiler as possible preferably on the nipple inserted directly into the rear boiler section using the wire ties provided. Make sure that the sensor makes good thermal contact with the pipe. See Figures Below.
3. Cover the sensor with a piece of insulation and tape in place.

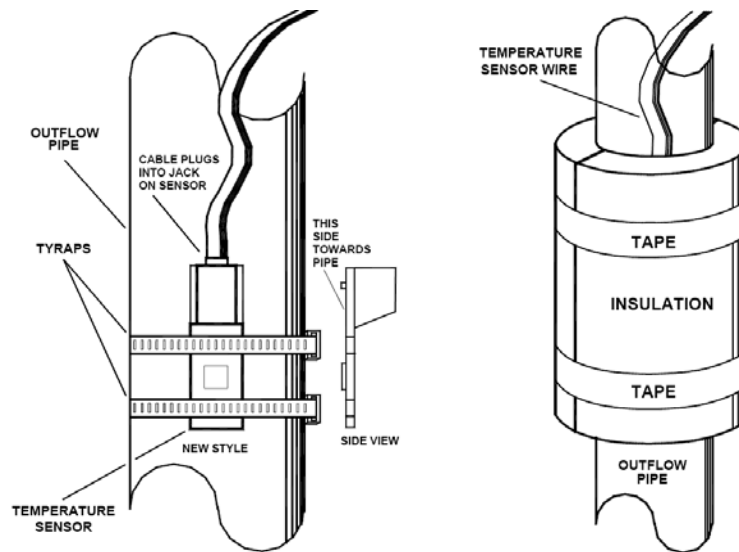

Domestic Water Sensor

The domestic water sensor if used plugs into the lower jack of the HW+ module.

The purpose of the second sensor is to detect a drop in the temperature of the domestic hot water. If it detects a drop in temperature it will override the economizing mode and allow the burner to fire if there is a call for heat already established.

This sensor is typically not required when using an indirect hot water heater. The indirect water heater functions just like any other zone in the heating system. When more domestic hot water is required, the indirect water heater will call for heat. The heat manager will detect this heat load demand through its standard sensor that is installed on the boiler supply pipe.

Electrical Wiring

Danger Electrical Wiring Must Conform to The National Electrical Code, ANSI/NFPA and Local Codes.

The boiler must be electrically grounded and on a separate fused disconnect switch.

Electrical shock is hazardous. Turn off all power supplies before starting to make any wiring connections or repairs.

Refer to wiring diagrams in this manual for electrical connections. The boiler should be connected to a separate, electrical supply circuit with a minimum 15 amp fused rating. Use No. 14 AWG wires rated for at least 90° C. Install a separate fused disconnect or safety switch near the boiler so all power can be shut off for servicing.

Caution: Label all wires prior to disconnection when servicing controls. Wiring errors can cause improper and dangerous operation. Verify proper operation after servicing.

1. Install the burner wiring harness supplied with the Solaia Sentry into the knockout on the side opposite of the burner door hinges. The 26" long harness supplied is for the Riello Burner. When using with a Beckett burner harness length needs to be reduced to approximately 9" by removing the 90° connector and cutting only the BX to length. Reinstall the 90° connector. When properly installed the burner swing door should not be able to be opened beyond a safe distance without separating the Molex plug connection.
2. Wire the incoming power to the Solaia Sentry as indicated in the wiring diagrams providing overload and disconnect means as required by code.
3. Wire the Low Water Cut Off into the control circuit. Refer to the Low Water Cut Off manufacturer's instructions for wiring of LWCO switch into the Solaia Sentry control circuit.
4. Install the room thermostat on an inside wall away from fireplaces, appliances or sunlight. Set the heat anticipator according to the instructions from the aquastat manufacturer. Connect the thermostat leads to the "TT" connections on the aquastat control or system control.
5. The indirect water heater, if used, may be wired in such a fashion that the indirect water heater has priority over the building heat. Commercially available circulator prioritizing packages are available.

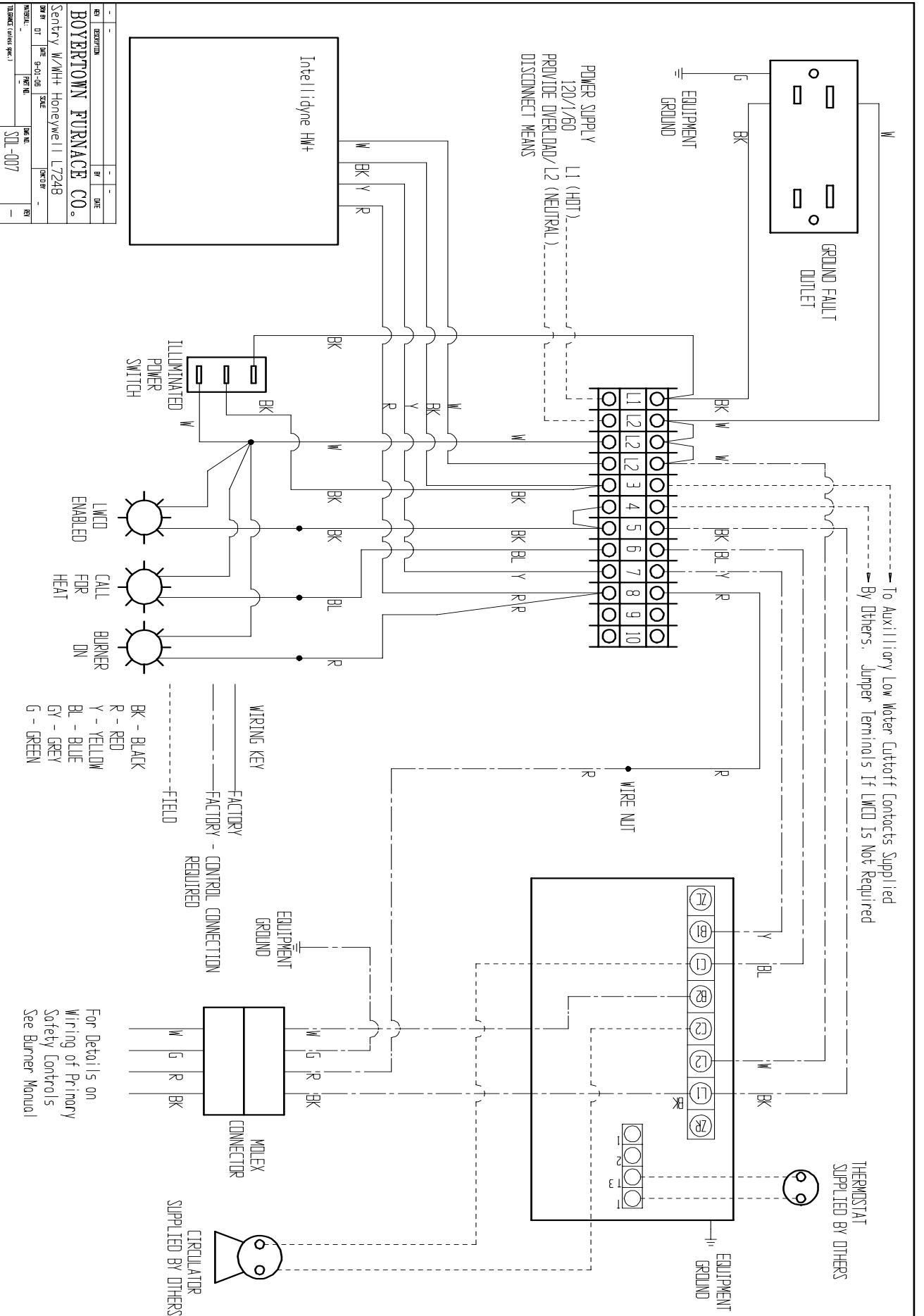

REV	DESCRIPTION	BY	DATE
1			

BOYERTOWN FURNACE CO.
Sentry W/WH Honeywell L724B

DATE	SIZE	PROJECT
9-01-96		

PROJECT: _____
JOB NO: _____
TITLE: SOL-007

System Checkout

1. Recheck all wiring connections.
2. Verify the proper installation of the HW+ sensor to the boiler supply piping and that it is plugged into the proper jack.
3. Set the HW+ switch to the Off/Bypass.
4. Restore power to the Solaia Sentry and turn the “Power Switch” to the on position as indicated by the illuminated switch.
5. To ensure the maximum savings, adjust the aquastat high limit set point temperature to a minimum of 170°F.
6. Set the HW+ switch to the “On” position. The HW+ will now go through a self test process.
7. If the HHW+ comes on and goes into the “Standby Mode”, force a call for heat by turning up the thermostat and verifying the change in the mode of the HW+ to either “Economizing” or “Burner Enabled”.
8. If the boiler water temperature is already below 120°F when a call for heat is established, the HW+ will go into the “Burner Enabled” mode and the burner will immediately start.

Control Circuit Safety Checks

Check the safety controls on the boiler after completing the oil burner adjustments. A safety control check for satisfactory performance must be performed.

1. High limit control - Remove the aquastat control cover as needed and note temperature setting. With the burner running reduce the high limit setting until the burner shuts off. Return the high limit to its original setting.
2. With the oil burner running verify proper operation of the low water cut off. Refer to the instructions provided by the low water cut off manufacturer for testing of the low water cut off. The oil burner should shut off when the low water cut off is functioning properly.
3. To check the primary control and flame sensor shut off oil supply with hand valve while burner is running, fifteen seconds after flameout, the safety switch locks out, ignition stops and the oil valve should close. To restart, open oil supply valve and reset safety switch.

Trouble Shooting Guide

Burner Will Not Start

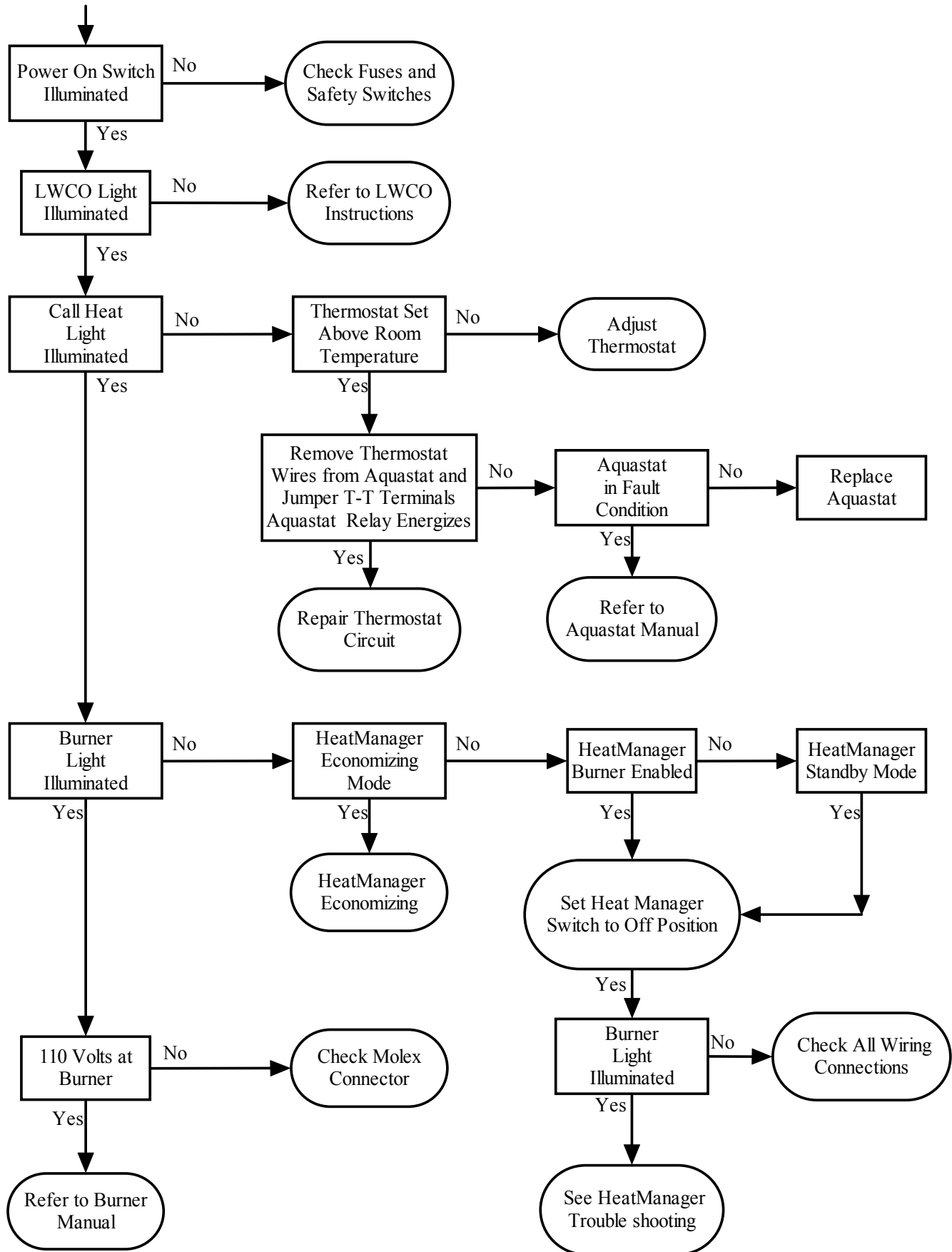

HW+ Programming

The following parameters may be changed in the field by following these instructions. *Pre-Purge time, Temperature indication in either degrees F or C, Heating Water Low-Limit, Domestic Water Low-Limit, Maximum Economizer Hold-Off Time, Standby-Timer Override, and whether or not the Economizer Time and/or Burner Run-Time Hour accumulators are Displayed.* The system may also be returned to factory default values and the Average Savings, Economizer Time, and Run-Time accumulators may be cleared.

All of the default values have been carefully selected to result in the greatest savings for the broadest scope of heating system applications. Individual system requirements may require changes. Please note that all of these programmable parameters will affect the amount of savings. Prudent changes are strongly advised. The default values are as follows:

Pre-Purge = 4 Seconds	HLOLIM = 120 ⁰ F
Temperature = F	DLIM = 115 ⁰ F
MAX ECON = 45 Minutes	RUN TIME = ON
ECON TIMER = ON	MAX STBY = 180 Minutes

To enter configuration mode, the controller must be powered up without any sensors connected. When prompted insert a water sensor plug into the DOM SENSOR connector. To confirm, remove the plug when prompted. The unit will then indicated that it has entered “***Config Mode***”. After a 4 second delay the display will advance to the first programmable parameter (RESET DEFAULTS?)

ALL PROGRAMMING IS ACHIEVED BY INSERTING AND REMOVING A WATER TEMPERATURE SENSOR PLUG INTO THE DOM SENSOR CONNECTOR, WHEN DIRECTED TO DO SO VIA THE DISPLAY ON THE CONTROLLER. THE SENSOR MUST BE CONNECTED TO THE CABLE OR THIS WILL NOT WORK!

YOU HAVE TEN (10) SECONDS TO RESPOND TO ANY OF THE DISPLAY PROMPTS. THE 10 SECOND COUNTDOWN IS DISPLAYED ON THE CONTROLLER’S LCD DISPLAY.

PROGRAMMING MAY BE STOPPED OR ABORTED AT ANY TIME BY TURNING THE CONTROLLER OFF. ANY PARAMETERS THAT WERE CHANGED WILL REMAIN CHANGED.

Reset Defaults

This parameter will reset all of the programmable parameters to factory defaults. It will not clear any of the accumulators.

Reset Savings

This parameter will clear the Estimated Savings accumulator.

Reset Econ Timer

This parameter will clear the Economizer Time accumulator.

Reset Run Time

This parameter will clear the Run-Time accumulator. *(Note: This value is accumulated even if not being displayed.)*

Prepurge = xxx Sec

This parameter indicates the pre-purge time currently programmed into the controller (default value 004 seconds). Next you will be prompted to change by inserting the sensor plug within 10 seconds. If not inserted within the 10 seconds the controller will advance to the next programmable parameter (For Degrees F or C). If inserted you will be prompted to force a burner call, typically done by increasing the set-point of the operating-control, and then to remove the sensor plug when the burner starts. When prompted to “FORCE A HEATING CALL” the controller will wait indefinitely (NO 10 second time-out) for the CALL. So it is not necessary to rush.

For Degrees C or For Degrees F

The controller will prompt you to change to whatever value is NOT currently selected (default value = F). For example, if the parameter is currently set for degrees F, the only choice will be to change to degrees C. This setting will alter the indicated values of the next two (2) programmable parameters, and how the indicated temperatures are displayed when the controller is in operation.

HLOLIM = xxx F

This parameter is used by the controller to set the low-limit temperature for the heating water. When the heating water temperature goes below this setting, the controller will no longer attempt to achieve any savings and will return control to the operating-control.

To change this setting, plug in the sensor when prompted. The indicated value will be what is currently set in the controller (default = 145°F / 62°C). Next the controller will count up until the maximum settable value is reached (160°F/71°C), and then will jump to the minimum settable value (90°F/32°C). Remove the sensor when the desired value is reached. If the ‘Heating’ water temperature goes below this value while the operating-control is calling for the burner to run, the controller will indicate “HEATING/LOLIM” on the display.

DLOLIM = XXX F

This parameter is used by the controller to set the low-limit temperature for the domestic hot water. When the domestic water temperature goes below this setting, the controller will no longer attempt to achieve any savings and will return control to the operating-control.

To change this setting, plug in the sensor when prompted. The indicated value will be what is currently set in the controller (default = 115°F / 46°C). Next the controller will count up until the maximum settable value is reached (150°F/66°C), and then will jump to the minimum settable value (90°F/32°C). Remove the sensor when the desired value is reached. If the ‘Domestic’ water temperature goes below this value while the operating-control is calling for the burner to run, the controller will indicate “HEATING/LOLIM” on the display.

MAX ECON = XXX MIN

This feature of the controller is to limit the maximum amount of time that the controller is allowed to remain in the Economizer Mode.

To change this setting, plug in the sensor when prompted. The indicated value will be what is currently set in the controller (default = 45 minutes). Next the controller will count up until the maximum settable value is reached (120 minutes), then “DISABLED”, and then will jump to the minimum settable value (10 minutes). Remove the sensor when the desired value is reached. If the controller goes in to the “HEATING MODE” as a result of this feature, there will be a period (“.”) appended to the word “MODE” on the display.

ECON TIMER OFF? or ECON TIMER ON?

This parameter controls whether or not the Economizer Time accumulator is displayed.

The controller will prompt you to change to whatever value is NOT currently selected (default value = ON). For example, if the parameter is currently set for “ON”, the only choice will be to change to “OFF”. Note – the accumulator is active even if not displayed.

RUN TIME OFF? or RUN TIME ON?

This parameter controls whether or not the Burner Run-Time accumulator is displayed.

The controller will prompt you to change to whatever value is NOT currently selected (default value = ON). For example, if the parameter is currently set for “ON”, the only choice will be to change to “OFF”. Note – the accumulator is active even if not displayed.

MAX STBY = XXX MIN

This feature of the controller is to limit the maximum amount of time that the controller is allowed to remain in the Standby Mode as a means of monitoring the internal electronics against failure. If a heating call is not sensed within the prescribed time period, the timer will expire and the control will take itself out of the circuit (fail-safe). A period (“.”) will be appended the “**STANDBY MODE.**” message to indicate that this timer has expired for service personnel. It will only reset upon sensing a call from the aqua-stat. Cycling power to the control will NOT reset the timer.

To change this setting, plug in the sensor when prompted. The indicated value will be what is currently set in the controller (default = 180 minutes). The controller will count up until the maximum settable value is reached (180 minutes), then “DISABLED”, and then will jump to the minimum settable value (45 minutes). Remove the sensor when the desired value is reached. **It is NOT recommended to disable the function.** This condition is not necessarily a fault. It will occur naturally if the heating system has been “off” or there are long periods of time between aqua-stat heating calls. The only time that this should be considered a problem is if the controller is in “STANDBY MODE.” and the burner is running. This would indicate a failure of the on-board electronics and that the IntelliCon has taken itself out of the circuit.

AFTER THE LAST PARAMETER IS REACHED THERE WILL BE A BRIEF DELAY AND THE CONTROLLER WILL RESET. DURING THIS TIME THE SENSOR(S) SHOULD BE RECONNECTED OR THE CONTROLLER WILL ATTEMPT TO GO INTO THE CONFIGURATION MODE AGAIN. IF YOU DON'T REACT QUICKLY ENOUGH, SIMPLY TURN THE CONTROLLER OFF, CONNECT THE SENSOR(S) AND TURN THE CONTROLLER BACK ON.

HW+ Trouble Shooting

After Installation and Checkout, the controller does not require maintenance and will provide years of trouble free operation. The unit may be taken out of the circuit at any time by placing the switch to the

‘Off/Bypass’ position. In this position, the unit has no effect on the system and the burner is controlled as it was prior to the IntelliCon controller’s installation. This allows service personnel to troubleshoot or work on the system without the controller intervening.

If at any time the Power/Normal light on the front panel blinks continuously, a sensor is not operating properly and The *IntelliCon*® controller has automatically gone into ‘bypass mode’.

If the message “TIMER FAULT” is displayed the switch should be placed into the OFF/Bypass position and service called.

If the burner is running and the control is in “STANDBY MODE” a problem exists and service should be contacted.

Limited Manufacturers Warranty

The Energy Manager Plus is warranted by Boyertown Furnace Company to be free from defects in material and workmanship for a period of two years from the date of manufacture or one year from the date of installation, whichever ever occurs first.

In the event of any claim under this warranty or otherwise with respect to this product is made within such period, we will repair or replace such products. In no event shall Boyertown Furnace Company be liable for any other loss or damage, whether direct, indirect, incidental or consequential.

This warranty is your exclusive remedy and shall be in place of any other warranty or guarantee, express or implied, including, without limitation, any warranty of merchantability or fitness for a particular purpose.

This warranty may not be assigned or transferred and any unauthorized transfer or assignment thereof shall be void and of no force or effect.

-----Cut and Return This Form or Register Online at www.boyertownfurnace.com-----

Warranty Registration

Boyertown Furnace Co.

P.O. Box 100

Boyertown, PA 19512

Date Installed: _____

Model Number: _____

Serial Number: _____

Name of Purchaser: _____

Purchaser's Address: _____

Dealer's Name: _____

Dealer's Address: _____
