

KALVIS[®]

**CENTRAL HEATING
SOLID FUEL BOILER**

**KALVIS-5-16(10), 5-20, 5-30
KALVIS-5-16(10)W, 5-20W, 5-30W**



**USER'S INSTALLATION
AND OPERATION MANULA**



LST EN 303-5

ГОСТ 9817-95

ЇСТ 144948958.13:2004

Barcode

ATTENTION !

Get acquainted with this technical certificate before installing the boiler. It shall help you to mount and operate the boiler as efficiently as possible.

1. Basic engineering data

Central heating solid fuel boiler "**Kalvis-5-...**", "**Kalvis-5-...W**" (hereinafter referred to as the boiler) is used for heating various premises where central heating system with natural or forced circulation is arranged.

Boiler has a socket for mounting 3x1,5...3x2 kW electric heating devices (with 2" thread) with temperature control and emergency thermostats or without them (devices not included).

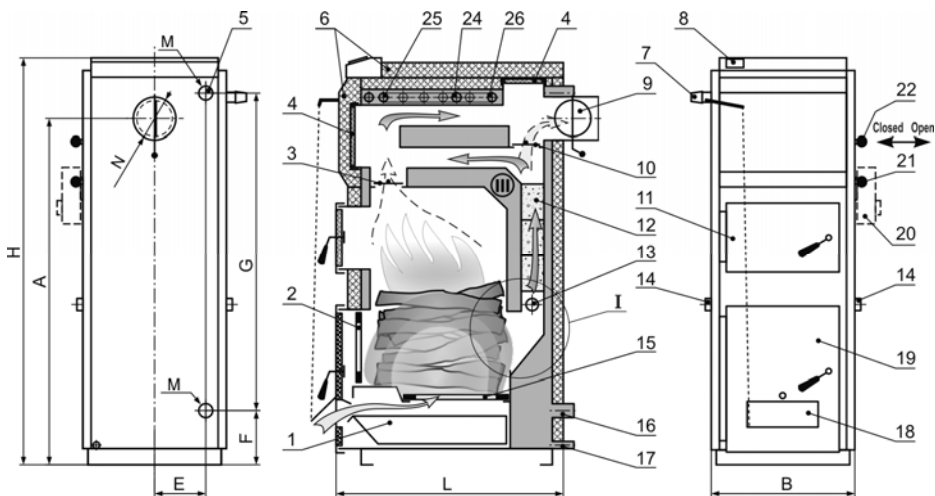

1 fig.

- 1. Ash tray. 2. Cast iron door. 3. Exhaust damper. 4. Servicing covers. 5. Hot water pipe. 6. Insulating shields. 7. Draught adjuster. 8. Thermomanometer. 9. Draught damper. 10. Ignition damper. 11. Fuel loading door. 12. Refractory bricks. 13. Secondary air pipe. 14. Secondary air damper. 15. Fire grate. 16. Return water pipe. 17. Drainage pipe. 18. Air supply damper. 19. Servicing door. 20. Electric heating. 21. Exhaust damper's handle. 22. Ignition damper's handle. 23. Removable refractory brick (only for **K-5-16(10)** and **K-5-16(10)W** types). 24. temperature sensor socket*. 25. Cooling water supply pipe*. 26. Cooling water exit pipe*.

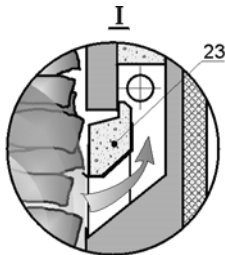

Letters mark dimensions provided in the basic engineering data table.

* Boiler cooling is only installed in "**Kalvis-5-...W**" types of boilers.

F-02/IN-04

To _____

Guarantee servicing request

Having acquainted with fireplace's "**Kalvis**" user's manual (Products No. _____) and having installed it as required I have following claims:

I. _____

I consider it a manufacturing error and I ask you to send your representatives to inspect the fireplace, determine the defects and remove them.

If the aforementioned defects are due to wrong installation and operation of the fireplace I shall cover the arrival costs of your representatives (_____) and the time spent for travel and on site at ____/hour for each representative including the driver.

My address _____ Phone number. _____

Surname

Signature

Notice: Request should be sent by a registered mail to the address specified in this passport, in case of emergency call specified phone number.



Boiler sold by: Company _____
 Sales date: _____
 Address _____
 Phone _____

Boiler installed by: Company _____
 Address _____
 Phone _____
 Foreman _____
 (name, last name, signature)

In case of a breakdown contact Company _____
 Address _____
 Phone _____

Manufacturer
UAB "Šiaulių tauro kalvis"
Pramonės 15,
LT-78137 Šiauliai, Lithuania
Phone: (+370 41) 540556
E-mail: prekyba@kalvis.lt

Basic engineering data:

Boiler type	<i>K-5-16 (10)</i> <i>K-5-16 (10)W</i>		<i>K-5-20</i> <i>K-5-20W</i>	<i>K-5-30</i> <i>K-5-30W</i>
Nominal output*, kW	10 **	16	20	31,5
Minimum output*, kW	6 **	10,5	12,5	20
Area heated when the thermal resistance of the building is 2,5, m ²	60 – 120 **	100 – 200	120 – 280	200 – 400
Fuel used	Fire wood, waste wood, saw dust and peat briquettes, coal			
Wood size L x Ø, iki, cm	37 x 10			40 x 10
Combustion chamber volume, dm ³ (l)	50		80	120
Fuel* combustion duration, val.				
- at nominal output:	2,8 **	2,5	2,8	2,8
- at minimum output:	4,8 **	4,0	4,8	4,8
Fuel used per heating season, m ³	8 – 12 **	10 – 16	15 – 20	20 – 25
Efficiency at nominal output not less than, %	80			
Boiler grade according to EN 303-5	3			
Water volume in the boiler, l	64		74	92
Water pressure in the boiler, not greater than, MPa (kgf/cm ²)	0,15 (1,5)			
Maximum permitted water temperature in the boiler, °C	100			
Minimal return water temperature during operation, °C	57			
Ambient temperature, °C	3 – 60			
Temperature adjuster control range, °C	65 – 90			
Parameters for the cooling water used to remove excessive heat ***, pressure, bar			≥ 2,0	
temperature, °C			≤ 15 ***	
Minimum chimney draught, Pa	16 **	18	19	21
Exhaust temperature*, °C:				
- at nominal output	226 **	249	245	242
- at minimum output	165 **	180	178	176
Loading hole dimensions, mm	230 x 2 92			
Overall dimensions, mm:	H	1160	1370	1370
	B	530	530	640
	L	980	980	1000
Connection pipe's dimensions:	M, G N, mm	G1½-B Ø158		G2-B 178 x 178
Cooling pipe's dimensions:	D; V1; V2, G	G ½-B; G ¾-B; G ¾-B		
Pipe location dimensions, mm:	A	1015	1180	1190
	E	145	145	195
	F	140	145	145
	G	925	1115	1115
Weight (<i>K-5...</i> / <i>K-5...W</i>) not greater than, kg	243 / 248		283 / 288	400 / 405

* 18-20 % moist content birch wood.

Firing boiler with wood that has more than 30moist content is not recommended%.

** With refractory brick (p.23, 1 fig.) in combustion chamber.

*** For the boilers with installed emergency cooling.

2. Design description

Due to constant development of design, minor inconsistencies with the manual are possible.

Boiler frame is welded from special sheet steel has water cavities, where water is heated (see 1 fig.). Internal boiler frame is made of 6 mm thick steel, external – 3 mm. Exterior of the boiler is covered with insulating shields. (p.6). On the front side of the boiler there is a draught adjuster (p.7), that controls the air supply damper (p.18), thermomanometer (p.8), door (p.19) beyond which there are cast iron doors (p.2) and an ash tray (p.1). Loading chamber is closed by the door (p.11). Inside the frame there is an exhaust damper (p.3) and ignition damper (p.10), that open up the flue way directly into the chimney and that are used when fuel is ignited or adding more fuel into the boiler; also there is a fire grate (p.15) and a secondary air pipe (p.13). In the secondary combustion chamber there are refractory bricks (p.12) that maintain the high temperature of combustion. Below the shields (p.6) there is a servicing cover (p.4) which allows access for cleaning of boiler internal surfaces.

On the side walls of the boiler there are secondary air control dampers (p.14).

On the backside of the boiler there is a drainage pipe (p.17), return (p.16) and hot (p.5) water pipes; smoke outlet with a draught damper (p.9).

On the side wall of **K-5...W** there are pipes for the emergency cooling. In the hole (p.24) (G ½-B) a bushing with the temperature sensor is mounted. Water from the main is connected into pipe (p.25) (pressure 4 ÷ 2 bar.); (p. 26) is for removal of heated water.

Electric heating device automatically turns electric heating on, when fuel runs out and temperature fall to the preset stand-by mode temperature.

In the combustion chambers of boilers **K-5-16(10)** and **K-5-16(10)W** there is a removable refractory brick (p.23). When it is set into the boiler, boiler output may be decreased from 16 to 10 kW, prolonging the combustion duration

It is prohibited to alter the design of the boiler.

3. Transportation and storage

Transport boilers only in the vertical position by all types of covered transport. Transporting by not covered transport is possible only when the weather is dry. Use additional protection means to protect boilers against fall downing and scratching. Striking, turning over or throwing boilers during loading, unloading or transportation time is strictly prohibited.

The boilers are to be stored in the dry rooms, where is no vapour of chemically active materials.

4. Boiler installation

Boiler has to be installed in the premises that meet, RSN-159-95 and RPST-01-97 requirements.

It is recommended to have mounted a smoke collecting cover above boiler. Boiler should be mounted vertically, or with forward inclination, which would not exceed 1 degree.

When boilers are installed outside of Lithuania it is necessary to meet the national requirements for installation of such equipment.

10. Complement.

1. Boiler " Kalvis-5- _____ "	- 1 unit
2. Poker	- 1 unit
3. Grinder	- 1 unit
4. Ash scoop	- 1 unit
5. Draught adjuster C20/25	- 1 unit
6. User's manual	- 1 unit

Electric heating device and temperature valve are not included

11. Guarantee

- Manufacturer guarantees that boiler conforms to manufacturing drawings, provisions and regulations of IST144948958.13:2004, and LST EN 303-5.
- Manufacturer applies the following guarantee servicing terms from the date of sales:

- Boiler frame – 24 months.
- Complement – 12 months.
- Consumables (para7) – 6 months.

Manufacturer will repair any malfunctions in the product that appear due to manufacturer's fault.

- Manufacturer will not acknowledge any quality claims for boiler operation and consequences if the product has been wrongly chosen, mounted, installed or serviced.

I am acquainted with rules of installation and servicing and guarantee policy:

Purchaser: _____
(name, last name, signature)

Use only boiler manufacturer's consumables and spare parts.

8. Fuel types and properties

Combustion heat of absolutely dry wood does not depend on the wood type and equals 4510 kcal/kg. So in order to compare different kinds of wood we need to assume their relative weight. 1m³ weighs:

- oak wood - 500 kg;
- birch wood - 450 kg;
- fir wood - 330 kg;
- asp wood - 330 kg.

The higher wood humidity is, the smaller calorific value. Decrease in calorific value of humid wood in comparison to 20% humidity wood:

- 30 % humidity - 10 ÷ 15 %;
- 50 % humidity - 35 ÷ 40 %.

Fresh cut tree has about 35 ÷ 60 % maist content. Wood cut in the beginning of winter or hard wood has the least amount of moist.

Peat and wood calorific value is similar.

1 kg of coal gives 2 ÷ 3 times more heat than 1 kg of wood.

Combustion of 1 kg of wood requires 4 ÷ 5 m³ of air, coal – around 10 m³.

The more ash is left – the worse fuel is.

Energy radiation from combustion of 1 dm³ of wood of 20 % humidity:

Wood type	Kcal	Kwh	Comparison to oak %
Oak, maple	2520	2,93	100 %
Ash	2460	2,86	98 %
Birch	2270	2,64	90 %
Alder	1900	2,21	75 %
Pine	1850	2,15	73 %
Asp	1810	2,10	72 %
Polar	1680	1,95	67 %
Fir	1610	1,87	64 %

Average coal caloric value 6500 kcal/kg (7,56 kWh/kg).

9. Certificate of acceptance.

Central heating solid fuel boiler "Kalvis-5-_____" factory Nr. _____ conforms to manufacturing drawings, provisions and regulations of IST144948958.13:2004, and LST EN 303-5 and is suitable for commissioning.

Boiler tested at 0,4 MPa pressure.

Hydraulic pressure test date _____

Date of manufacturing _____

Quality assurance manager _____

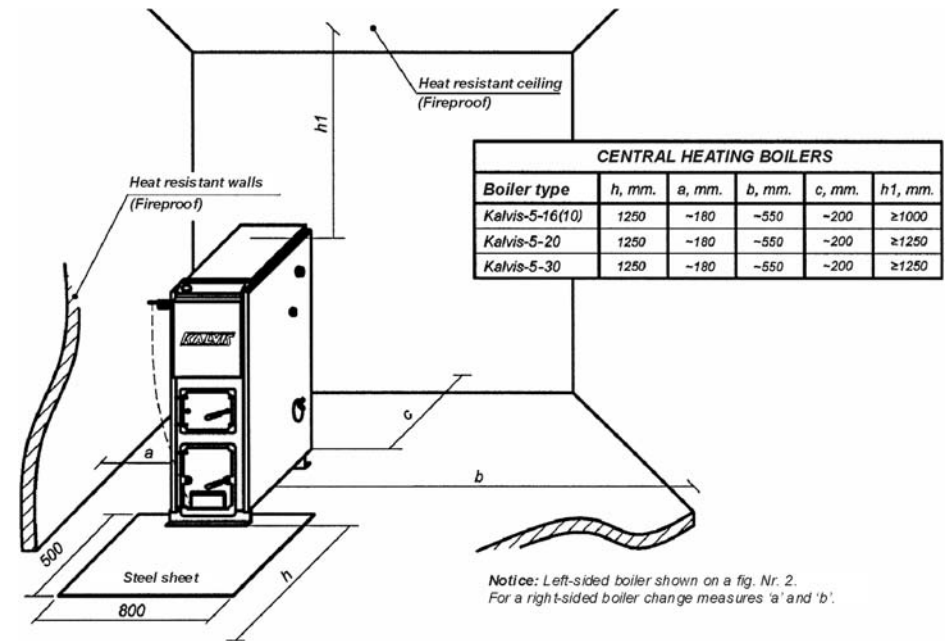

2 fig.
Recommended distance from the non flammable partitions

4.1. Fire precautions:

- * Boiler should be placed on the incombustible material;
- * If boiler is connected to the chimney by metal pipes, pipes should be not thinner than 1,5mm and they have to be covered by thermal insulation

Attention !

When chimney's draught is too great and sawdust is used for fuel sparks may fly out through the chimney.

It is prohibited to use sawdust for fuel, if the distance between chimney and flammable roof or other flammable structures is less than 20 m!

4.2. Requirements for chimney

Chimney design and boiler connections into it are shown on the fig 2 and 3.

- Chimney draught is not less than specified in main technical data table;
- Chimney hole's cross section should be not less than 120x270 mm;
- Boiler needs a separate hole for the chimney connection. No other connections through that hole are allowed.
- If chimney is connected with additional elbow, it's cross section has to be not less than that of the boiler smoke pipe, and bending radii not less than 100mm;
- Pipe from the smoke pipe to chimney may not be longer than 1,5 m and lean upwards toward chimney;

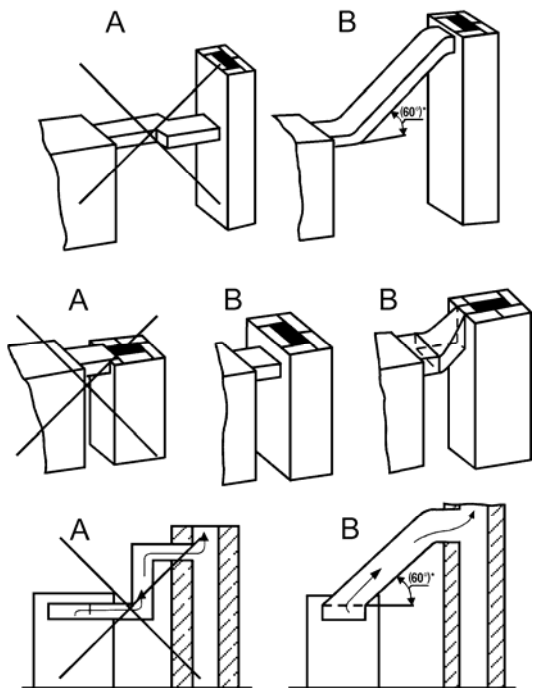

3a fig.

Boiler to chimney connection.

* not less than 60° A - incorrect B - correct

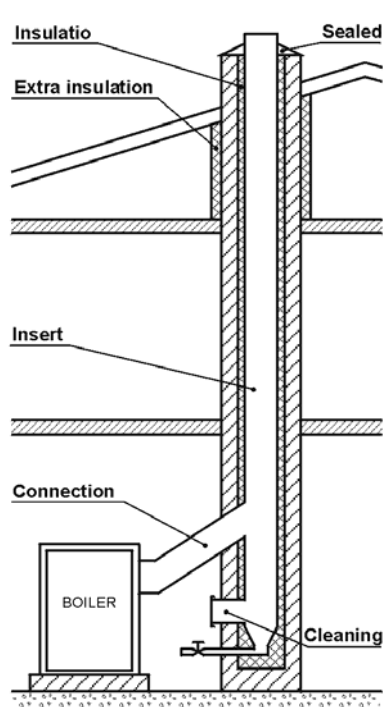

3b fig.

Chimney insert installation

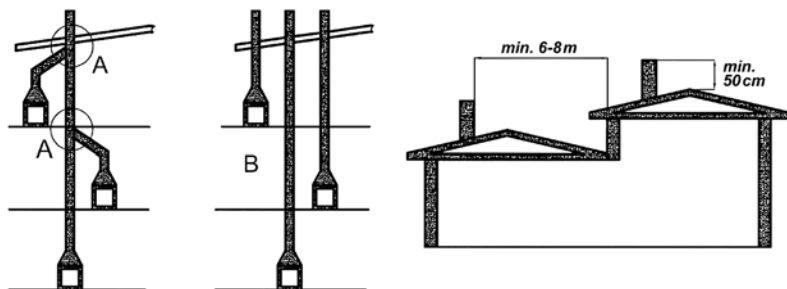

3c fig.

- Joints have to be well sealed;
- Chimney hole has to be cleaned periodically.

It is necessary to know that:

- Smoke continues to cool in the chimney, vapor condenses on the chimney walls, especially in the unheated loft and on the outside of the building;
- Condensate acids and erosion may destroy the chimney in few years;
- Not cleaned soot in the chimney may self-combust and become the cause of fire.

Malfunction	Reason	Removal
Boiler overheats	Too intensive combustion. Power outage (for systems with forced circulation).	Close air supply dampers, monitor boiler temperature. When temperature falls return to the regular firing.
Power outage		Call the electrician. During winter when the power is out for a prolonged period of time when there is a risk of system freezing down, drain the system.
Boiler does not reach nominal output	Bad, humid fuel. Poor draught.	Use dry fuel, open up ignition damper. Check chimney draught.
Boiler "tears"	Bad fuel. Return water temperature is too low (>57°C !). Poor draught.	Use dry fuel. Adjust the mixing valve.
Overpressure in the boiler	Boiler overheats. Protection valve malfunctions. Expansion tank malfunctions.	Close air supply dampers, monitor boiler temperature. Check and replace in case of necessity protection valve and an expansion tank.

6. Safety precautions

It is prohibited to:

- Disassemble boiler or electric installation;
- Connect boiler to the system without protection valve, that keeps pressure in the system below 0,15MPa (1,5 kgf/cm²);
- Close hot or return water valves when boiler is operated;
- Store dry fuels or other combustible materials close to or on top of the boiler;
- Store fuel closer than 500 mm to boiler;
- Ignition fuel with combustible liquids (petroleum, kerosene etc.);
- Operate boiler with doors and covers open;
- Allow children into the boiler room without adult supervision;
- Operate boiler with electric heating devices without having it grounded;
- Rapidly open loading doors during combustion (open a little, wait, then slowly open wide);

Necessary to:

- Monitor grounding efficiency.

7. Consumables

Glazing gaskets, secondary air pipe, fire grate and cast iron doors, refractory bricks may all fail during operation.

Consumables may be purchase from authorized distributors or the manufacturer of the boiler.

Firing the boiler requires a lot of air, so it is important that the sufficient amount is supplied into the boiler room.

Recommended fuel moisture content is not greater than 15-22 %.

Notice: Upon ignition of fuel, when there is still no soot on the boiler internal walls, water condensate forms that gives the impression that the boiler is not water tight. Water vapour condensate disappears when the temperature in the boiler reaches 70-80°C degrees. It is recommended to keep the water temperature in the boiler as high as possible. When the return water temperature is lower than 57°C, water vapours condense on the internal boiler walls and condensate together with products of combustion forms aggressive acids that may significantly decrease the lifespan of the boiler.

To make sure that the boiler is water tight it has to be fired intensively for several hours. The firing has to be stopped and the amount of condensate forming has to be monitored. If the amount of condensate does not increase – boiler is water tight.

5.3. Installing and adjusting the draught adjuster

Draught adjusters manufactured by Swedish ESBE C20/25 with protection from boiler overheating or without it are used. Adjuster is turned into a socket, scotch tape is used for sealing, Attach chain to air supply damper.

When boiler heats up to 70°C, adjust adjusters handle to position "4" and shorten the chain so that, air supply damper is closed. Turning adjuster to the correspondent position sets desired temperature. Position "6" corresponds to 90°C. Temperature increment between positions is 10°C.

5.4. Katilo valymas.

Ash that settles down beneath the fire grate may restrict air access to the combustion chamber. Ash tray and ash pit has to be emptied once every 2 days.

In order to ensure efficient boiler operation soot from the internal boiler frame walls has to be periodically. Cleaning intervals depend on fuel quality (especially moisture content) and chimney draught. Cleaning should be performed when the layer of soot reaches 3mm, but not less frequently than 2-3 times per month. Remove covers p4 and dampers 3; 10 before cleaning the internal boiler surfaces.

Hard solids may be removed by chemical cleaners. Swedish „Fauch 300“ cleaner or cleaners used for fireplaces glass may be used.

Chimney should be cleaned at least once a year before the heating season.

Notice: During the first ignition (or after not having fired the boiler for a long time) smoke may be blocked in the chimney. In such an event, during ignition, open up the chimney connection or cleaning hole and stick a burning piece of paper through it. Close the door when it burns down. Draught should improve.

5.5. Possible dangers and means of their removal

Boiler is protected against the overpressure by the protection valve and the expansion tank.

It is recommended:

- Install a stainless steel insert in the chimney. Well installed insert protects chimney from the effects of condensate and moisture;
- Insert should not significantly decrease chimney hole's cross section;
- Connected parts of the insert should be well sealed (not by soldering);
- Condensate collector should be mounted in the bottom;
- The gap between the chimney and an insert should be filled with non flammable material at least at the top of the chimney. The gap on top should be sealed and covered with steel sheet with a lean towards the edge of the chimney;
- Chimney in the cold loft should be insulated by a non flammable insulation;
- If residue in the chimney catches fire close the air supply into the boiler and call the firefighters.;
- Arrange holes in the chimney connection for periodic soot cleaning (once in a month);
- It is recommended that chimney is inspected at least once a year by a qualified chimney supervisor.

4.3. Requirements for the connection to the heating system:

- Boiler may be connected to the heating system according to the project prepared by heating equipment specialists or works may be performed by a well qualified plumbing welder who is well acquainted with this manual and boiler design.
- Boiler should be connected by hot and return water pipes not smaller than 1.5'' in diameter
- Boiler may be connected to the heating system with the expansion tank, where operating pressure does not exceed 0,15 MPa (1,5 kgf/cm²);
- If system pipes have valves, that disconnect boiler from the system, mounted, they have to be fully opened. To avoid break down due to inadvertence, valve handles should be removed.
- It is necessary to mount the protection valve that keeps the operating pressure in the system not greater than 0,15 MPa (1,5 kgf/cm²). Valve's operation should be checked upon ignition by turning it's handle.
- In order to avoid forming of the condensate, which may significantly reduce the lifespan of the boiler it is necessary to install the four way mixing or thermostatic valves into the system (see recommended connection schemas). These valves allow to maintain the return water temperature not lower than 57°C;
- it is recommended that boiler is inspected at least once a year by a qualified boiler supervisor;
- Drainage pipe is used to remove water from the boiler and the system when there is a risk that the system will freeze.
Recommended boiler connection schemas are shown in figures 4a – 4d.
- When boiler is operated at lower than nominal output efficiency drops, environmental indicators are getting worse as well. In case of an emergency (when the circulation pump is not working) boiler may overheat. That is why it is recommended to use boiler connection schemas with accumulation tanks (fig. 4c, 4d). Minimum volume of the accumulation tank has to be calculated according to the formula given by the fig. 4d.

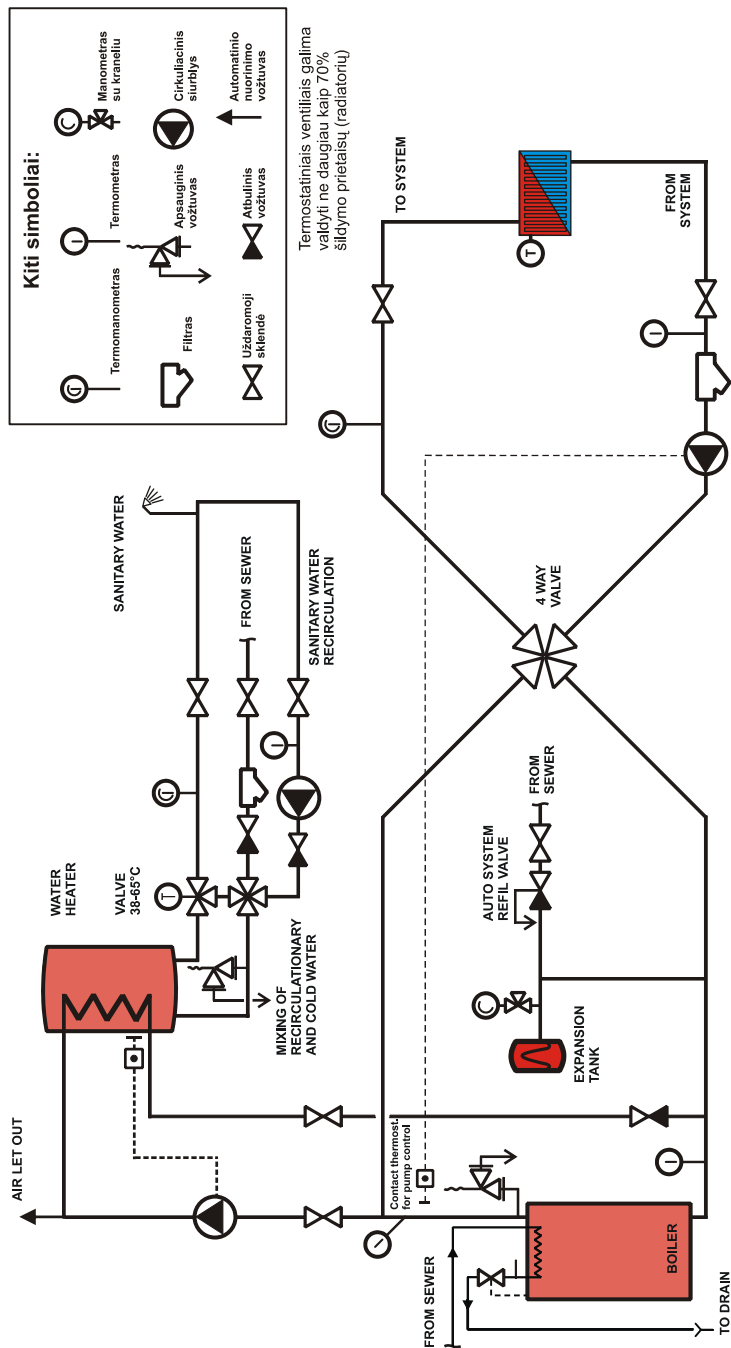

4a fig.
Recommended local heating system schema with the four way valve.

5. Servicing of the boiler

Only adults that are well acquainted with the design and users manual may service the boiler.

Attention! When firing the boiler with humid fuel or sawdust condensate and combustible gases form acids that significantly decrease the lifespan of the boiler.

Firing boiler with fine fuels is prohibited due to a danger of explosion and draughting out of the burning particles through the chimney.

5.1. System preparation for heating

Fill system with water and let the air out. Check if valves disconnecting boiler from the heating system are fully opened and remove their handles.

5.2. Firing the boiler (fig. 1)

Open exhaust damper (p.9) and ignition damper (p. 10) before firing the boiler. Place some chopped wood on the fire grate through the door (p.2)and ignite it. Secondary air pipe's (p.13) dampers have to be closed. Dampers (p.14) are adjusted reguliuojamos, when water temperature in the boiler rises up to 60°C.

When fuel is well ignited, combustion chamber may be loaded with fire wood or coal. Ignition damper (p.10) is closed. Finer wood increases boiler output. Chimney draught is adjusted by damper (p.9).

Wood should be loaded freely, so that it is able to fall down during combustion.

Coal is added in layers, depending on quality and required heat amount. 10cm thick layer of coal should be added for about 5-10kg of fire wood.

When adding more fuel:

- Open exhaust damper (p.3);
- Open ignition damper (p.10);
- Open door (p.19) and check if the ash does not block the air passages in the fire grate. Stir the bottom layer of fuel if necessary;
- Remove the chain of the draught adjuster (p.7) from the damper (p.18), so that the damper is tightly closed;
- Open up the loading door (p.11) slightly, in 5...10 seconds open it fully and add more fuel;
- Close loading door and dampers tightly;
- Attach the draught adjuster's chain to the damper.

Check the smoke color flowing out of chimney. Smoke should be thin of a light grey color. If smoke is thick and black it means incomplete combustion, not enough secondary air. Open secondary air supply dampers.

As a part of combustion process ash is formed, it blocks the openings in fire grate, boiler output and combustion intensity drops. Stir the fuel and ash. Excessive ash in an ash tray blocks primary air supply, that is why ash needs removal.

Keep the loading doors (p.11) shut when firing the boiler.

4.4. Boiler cooling system connection

A cooling loop is installed into the boiler *Kalvis-5...W* which serves as a protection against overheating.. When water in the boiler heats up to 95°C valve is opened and cold water from the main flowing through the cooling loop cools the water in the boiler. Water after the boiler is directed into the sewer via pipes that are not smaller than pipes shown in 1 fig., p. 26. (water has to flow freely into the sewer).

Honeywell TS 130 ttemperature valve is included.

In case of a power failure in the house where the water supply is local (water is supplied by a pump) boiler may overheat (water circulation pumps stopped). It is necessary to have an additional water supply into the cooling system f. e. an extra tank.

Recommended cooling schemas are shown in 4a – 4d figures.

Cooling loop may also be used for preparation of a small quantity of hot sanitary water. Tests show that when the water temperature in the boiler is 75°C, and the temperature of the water supplied into the cooling loop at 2.2l/min is 15°C, water in the cooling loop upon exit warms up to 42°C. But when the water flow is increased up to 5 l/min., temperature upon exit reaches only 32°C. In order to use the cooling loop for whot sanitary water preparation it is necessary to know that the temperature upon exit depends on:

- Boiler water temperature;
- Temperature of water upon entrance into the cooling loop and the amount of hot water used, i.e. the water flow through the cooling loop.

4.5. Requirements for electric connection

If electric heating devices are installed:

- Electric heating devices may be installed into the boiler when boiler was connected to the system according to fig. 4a;
- Only a qualified and licenced electrician may install the heating devices;
- Installation works should be performed according to the prepared project (assuming the total output of the main.).

Recommended electric heating device connection schema is shown on fig. 5.

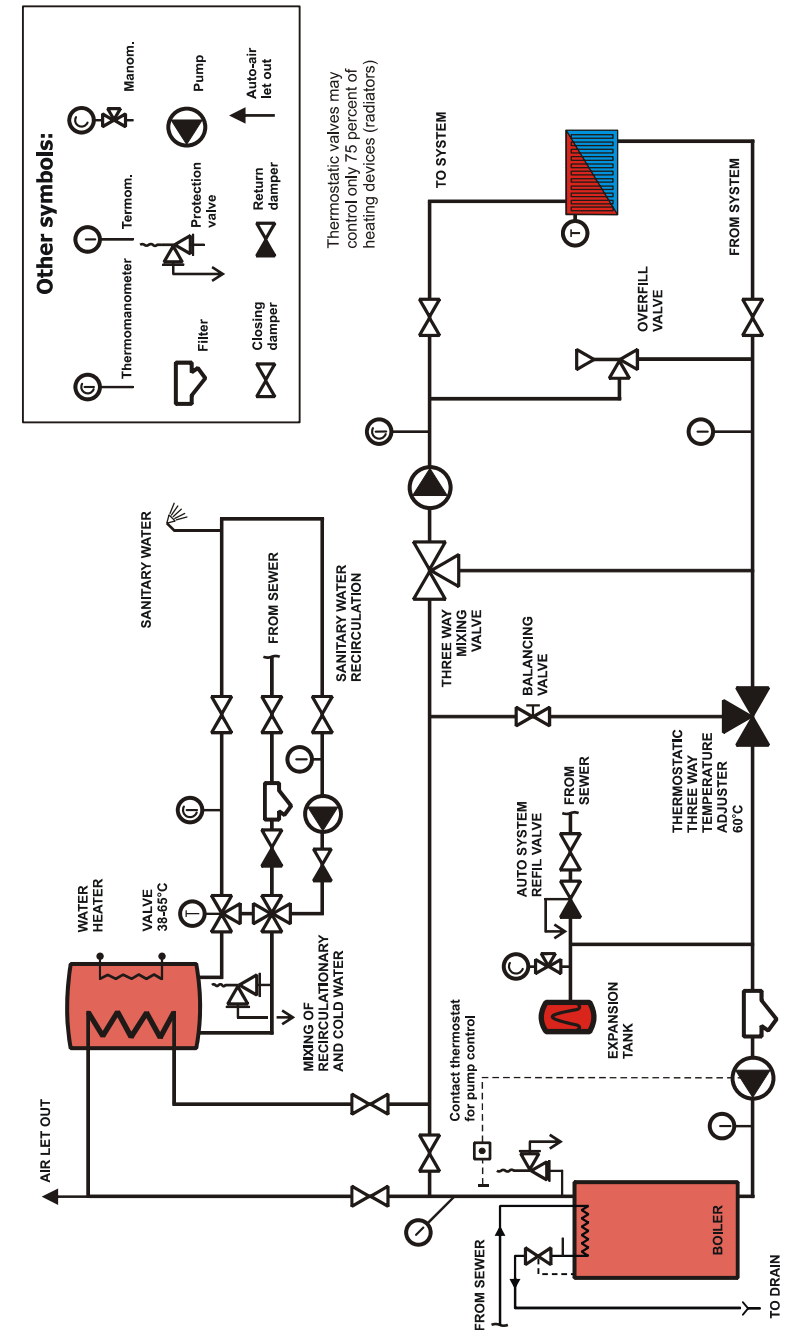
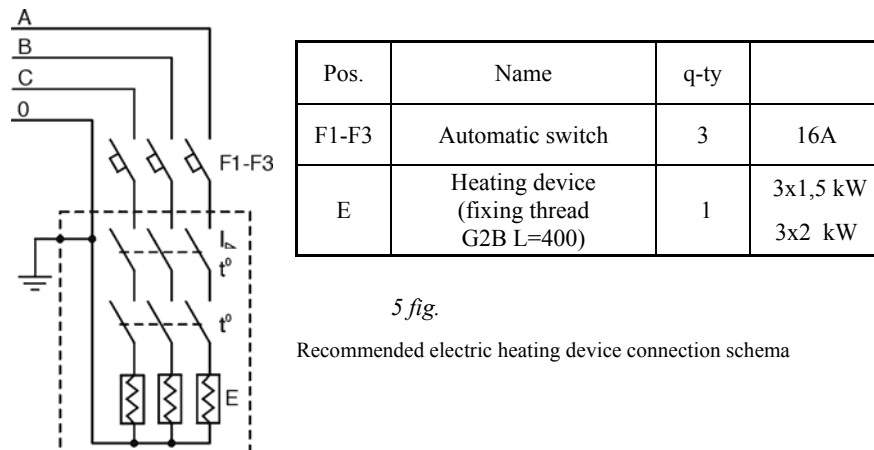

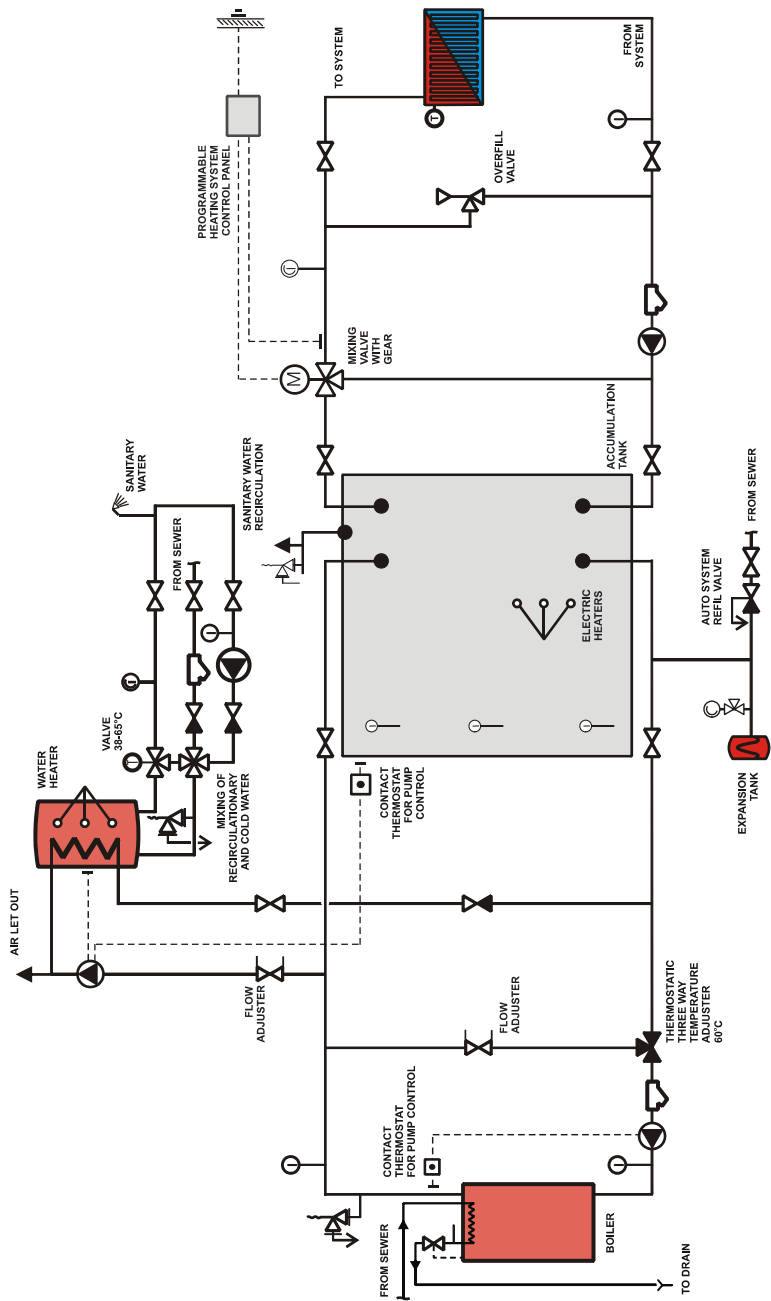

4c fig.

Recommended local heating system schema with the 3 way valve and accumulation tank.

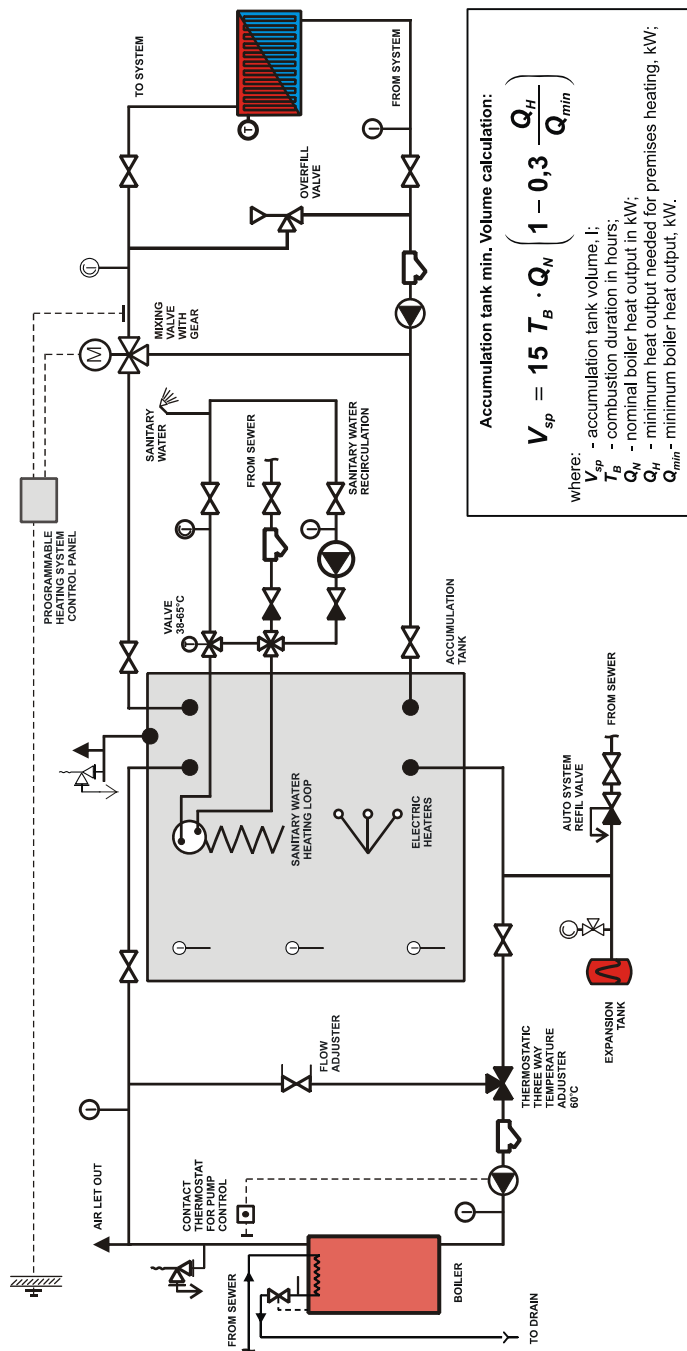

4d fig.

Recommended local heating system schema with the 3 way valve and accumulation tank.