

OWNER'S MANUAL

Belmont 3 Drawer Media Chest

5681026KP

caution

carefully read instructions and procedures for safe operation

product code

0-07816202-1

upc code

0-2998656811-3

date of purchase

____/____/____
receipt of purchase



attach here



Visit www.ameriwood.com to view the limited warranty valid in the U.S. and Canada.

Visite www.ameriwood.com para ver la garantía limitada válida solamente en Estados Unidos y Canadá.

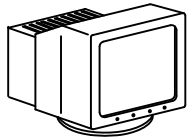
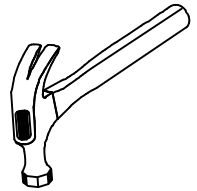
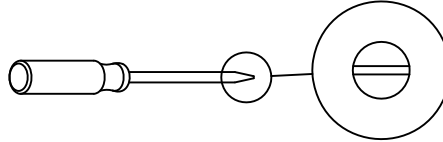
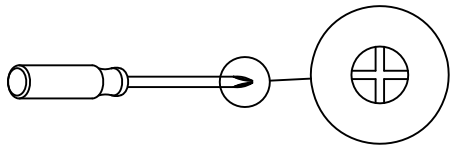

WWW.AMERIWOOD.COM/PARTS

(available 24 hours a day, 7 days a week)

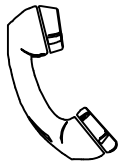

1-800-489-3351

(in U.S.A. only)

Monday - Friday
9:00 am - 5:00 pm
Central Time



1-636-745-1005

Lunes - Viernes
9:00 am - 5:00 pm
Tiempo Central



AMERIWOOD
410 East First Street South
Wright City, MO 63390 USA
Attention: Consumer Service

PARTS - PIEZAS

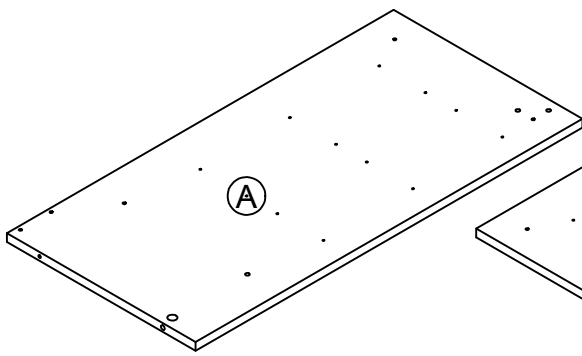

left panel
panel izquierdo
35681026010

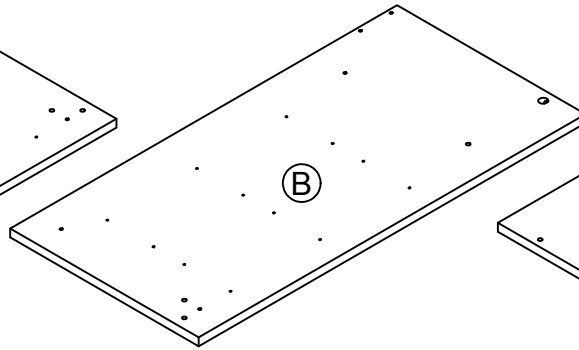

right panel
panel derecho
35681026020

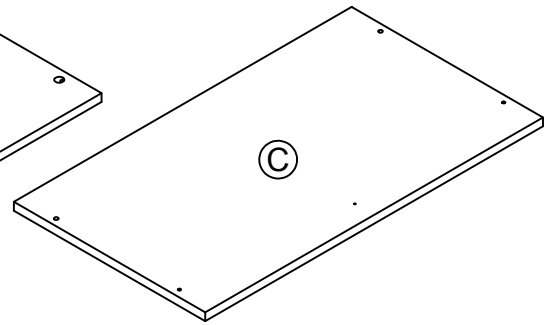

top
parte superior
35681026030

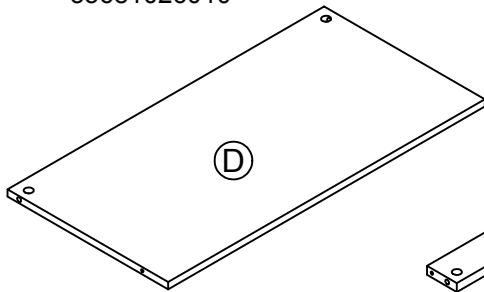

bottom
fondo
35681000040

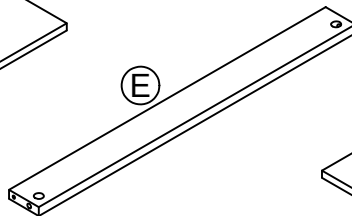

front rail
carril de frente
35681026050

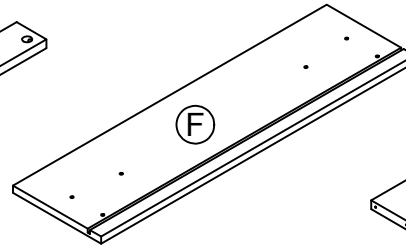

3 drawer fronts
3 frentes del cajón
35681026060

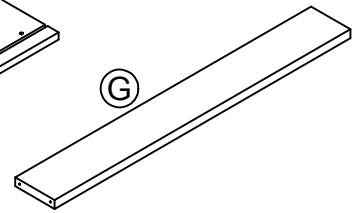

3 drawer backs
3 traseros del cajón
35681000070

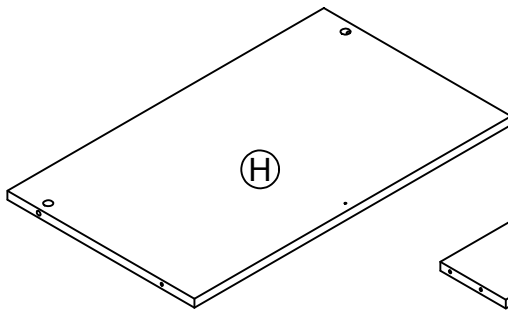

fixed shelf
estante fijo
35681026080

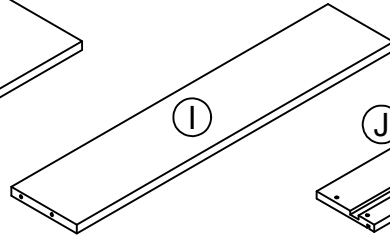

solid back
panel trasero solido
35681026090

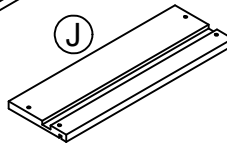

6 drawer sides
6 lados del cajón
399900810

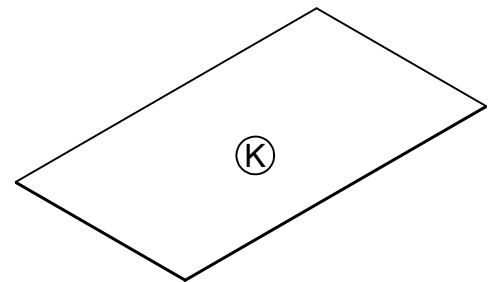

3 drawer bottoms
3 partes inferiores del cajón
K6340064

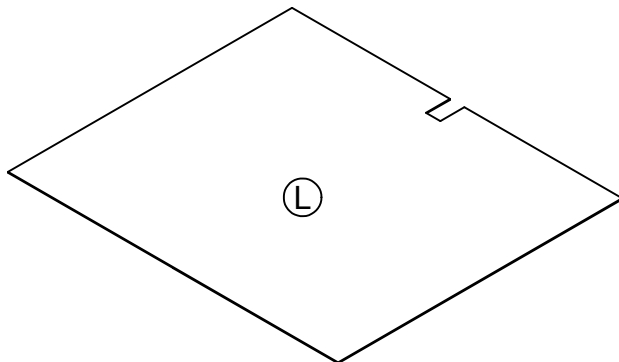

back panel
panel trasero
K56810000

stopper pins
pasadores de tope

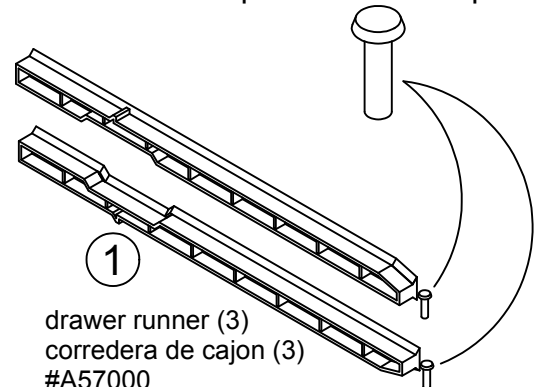

1
drawer runner (3)
corredera de cajon (3)
#A57000

PARTS - PIEZAS

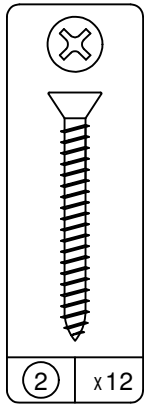

#A11600
1-1/4" flat head
cabeza plano 1-1/4"

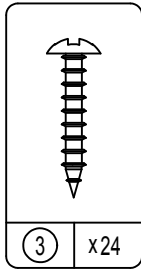

#A12610
3/4" pan head
cabeza redondo 3/4"

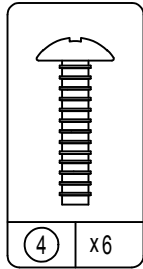

#A17300
3/4" machine screw
tornillo de máquina 3/4"

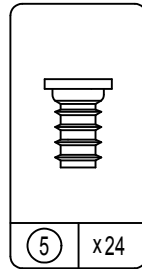

#A15600
drawer screw
tornillo de cajón

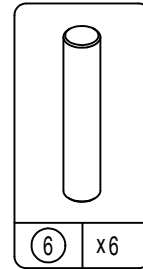

#A21500
steel dowel
clavija de acero

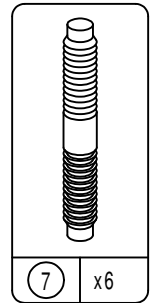

#A21520
compression dowel
clavija de compresión

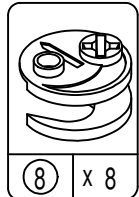

#A22500
cam lock
cerradura de leva

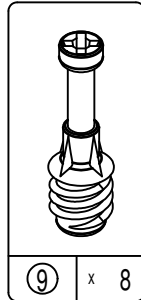

#A22510
cam bolt
perno de leva

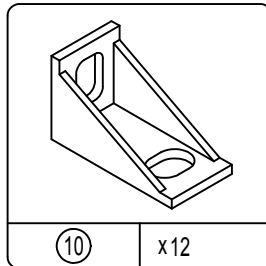

#A53760
drawer bracket
soporte del cajón

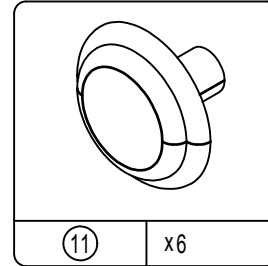

#A51960
knob
tiron

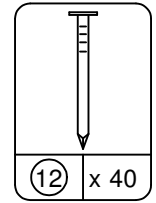

#A21110
nail
clavo

This illustration shows how the cam fastening system works.
Esta ilustración muestra el sistema de fijación de leva y como funciona.

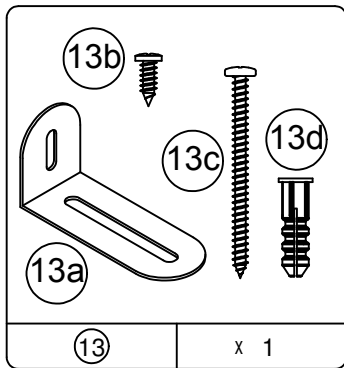

#A84050
safety bracket kit
estuche de soporte de seguridad

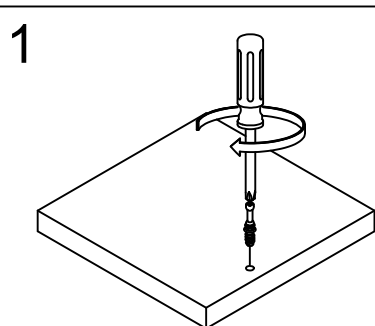

Tighten to fully seat. Do not over tighten.
Apriétese a totalmente asiento. No haga encima de apriétese.

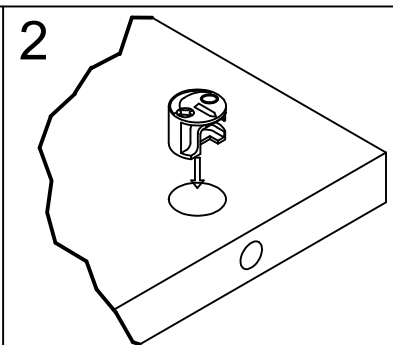

Proper orientation of cam.
La orientación apropiada de leva.

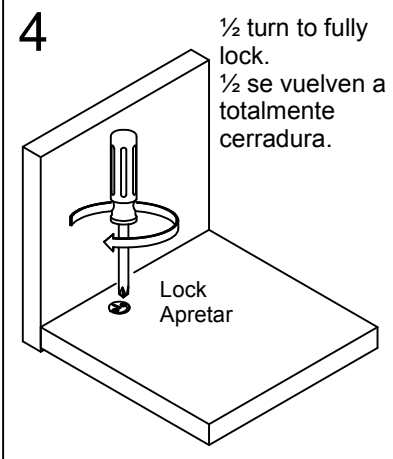
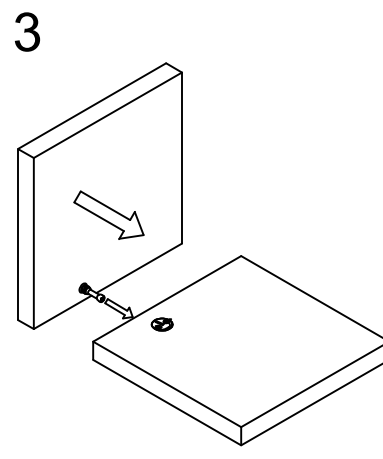

1/2 turn to fully lock.
1/2 se vuelven a totalmente cerradura.

Lock
Apretar

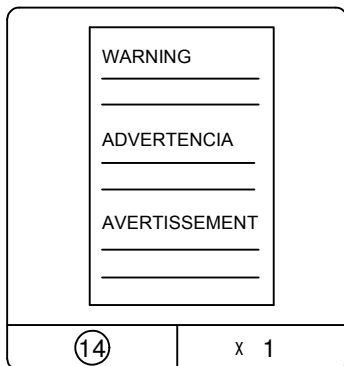

#B64325
TV warning label
Etiqueta de advertencia de TV

1

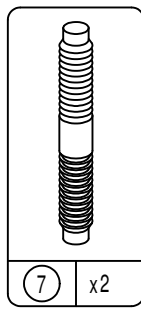
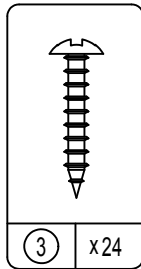
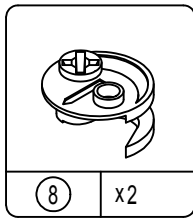
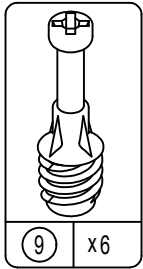

marked with an "L"
marcado con un "L"

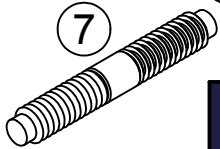
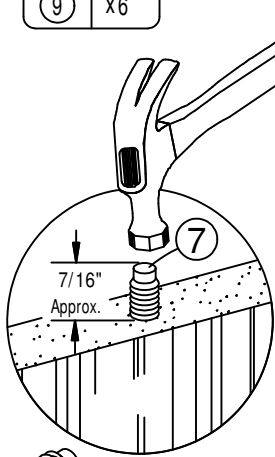
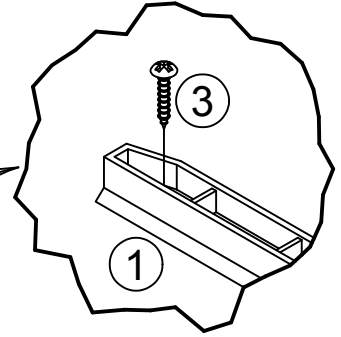

**RAW EDGE
BORDE CRUDO**

A

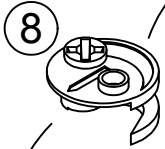

proper orientation
posición correcta

B

**RAW EDGE
BORDE CRUDO**

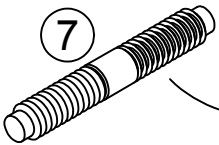

marked with an "R"
marcado con un "R"

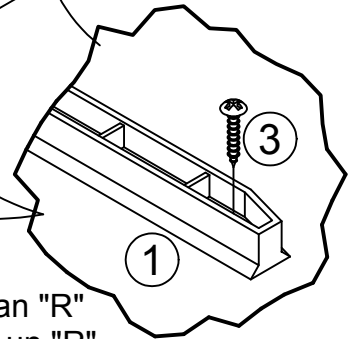

2

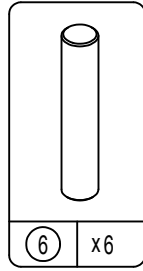
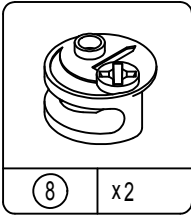

proper orientation
posición correcta



proper orientation
posición correcta

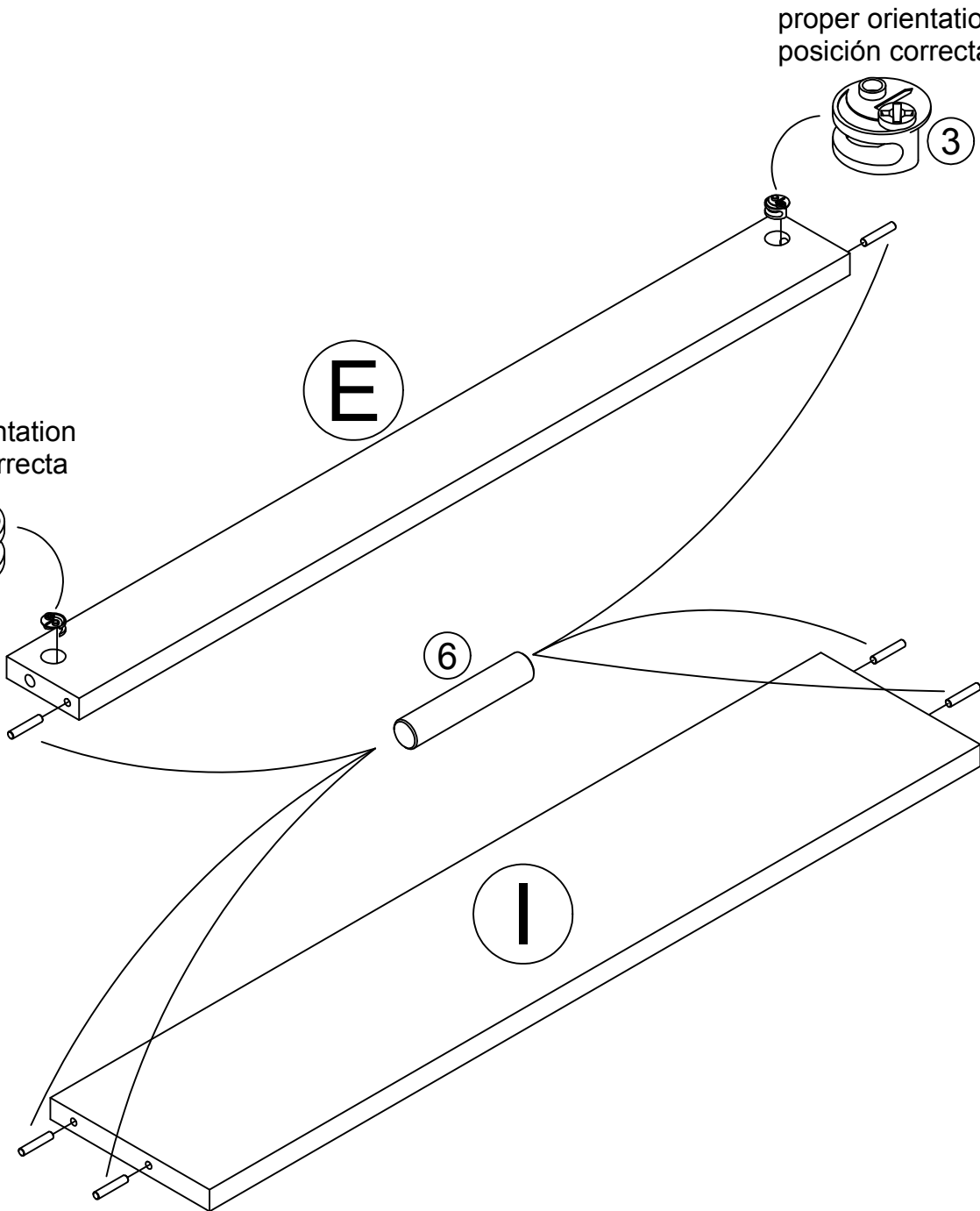
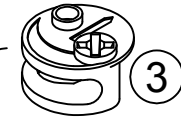

3

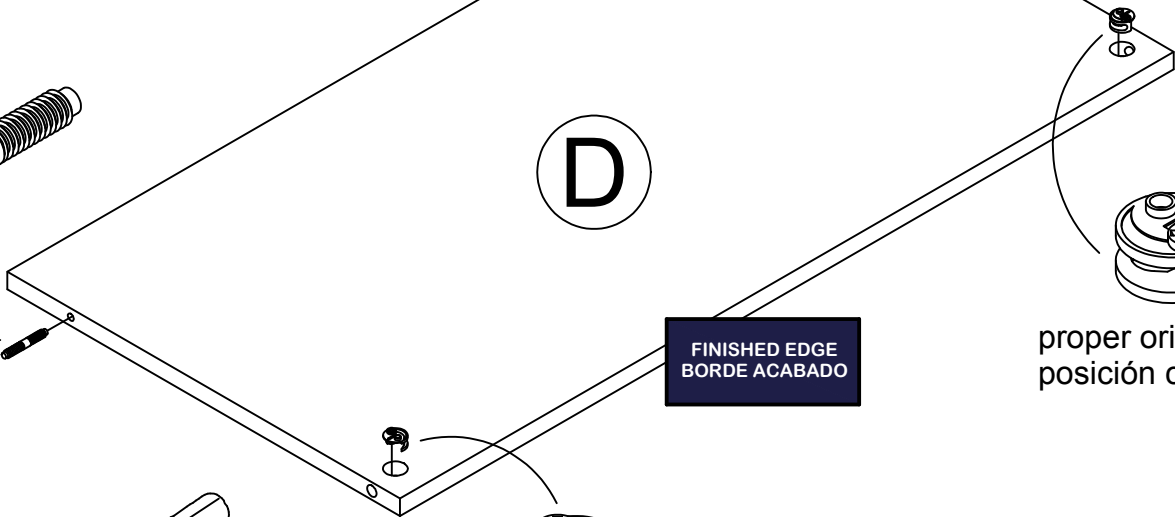
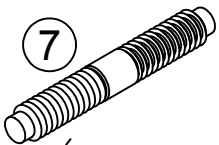
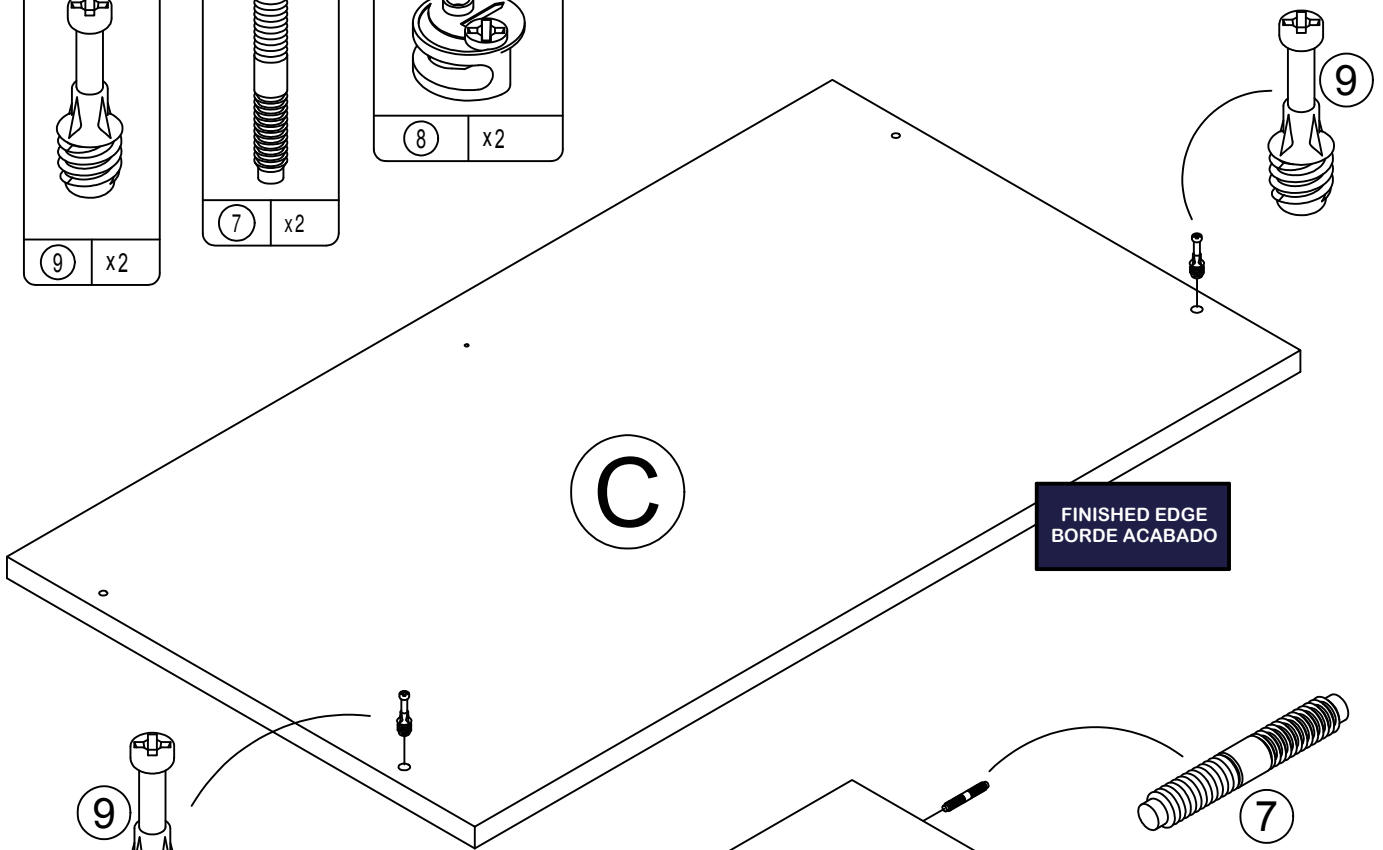
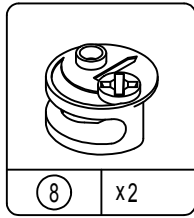
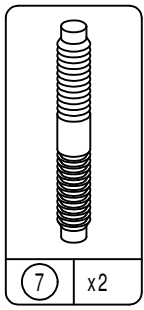
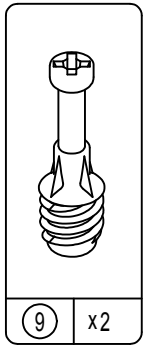

proper orientation
posición correcta



proper orientation
posición correcta

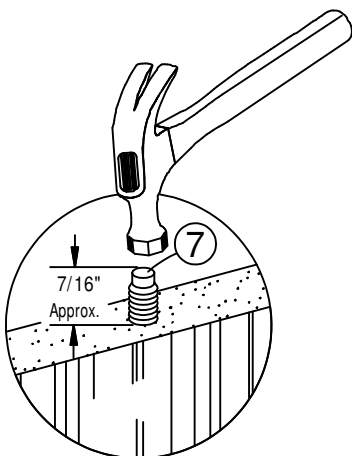

4

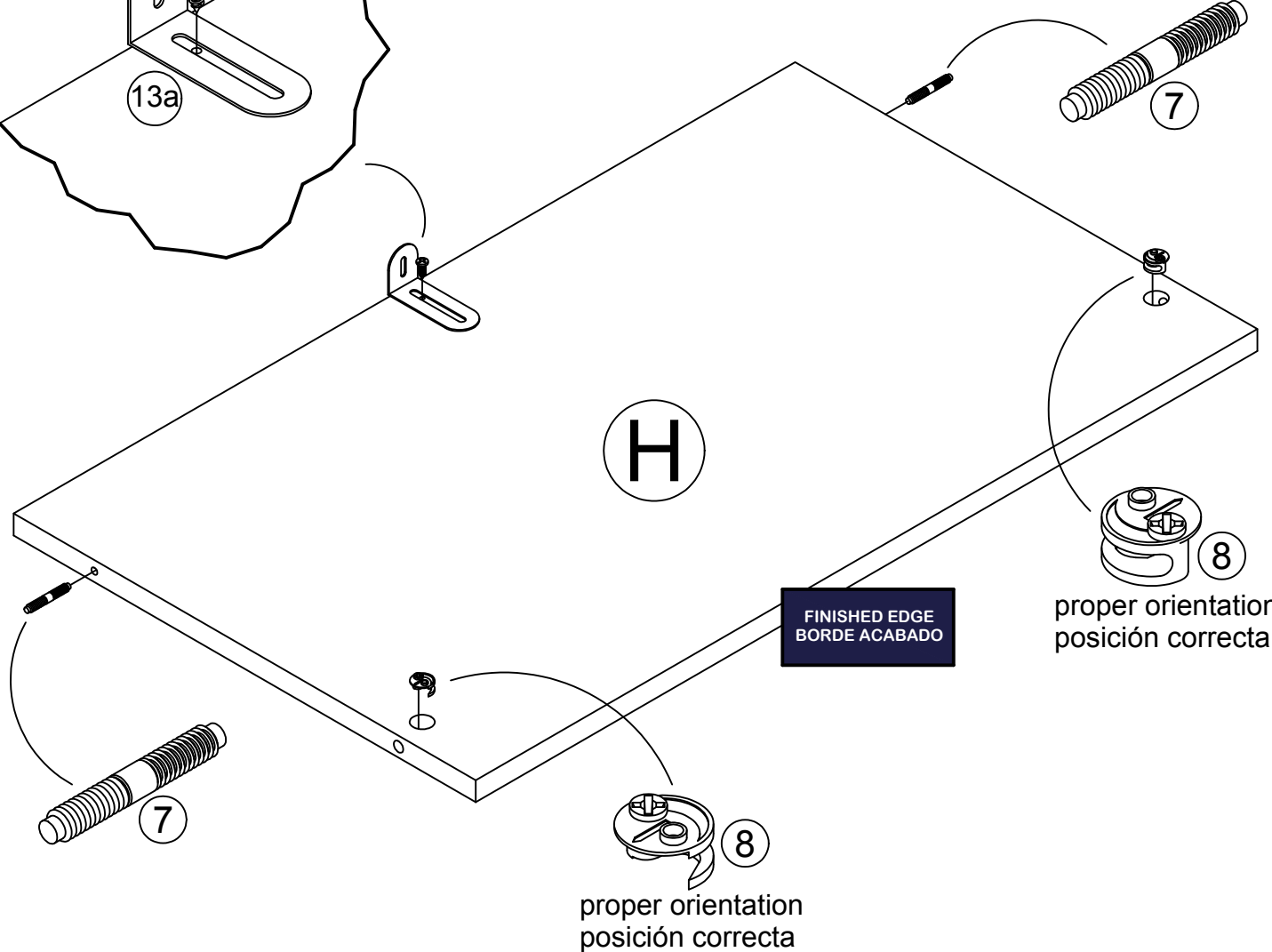
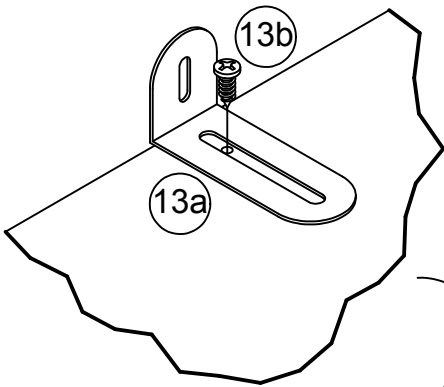
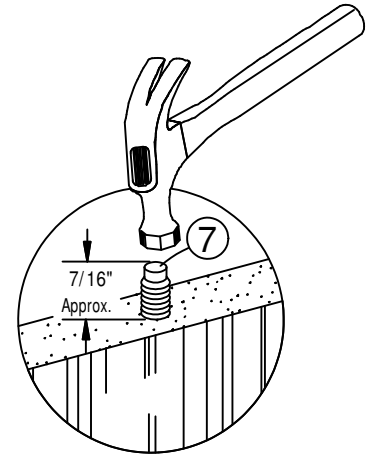
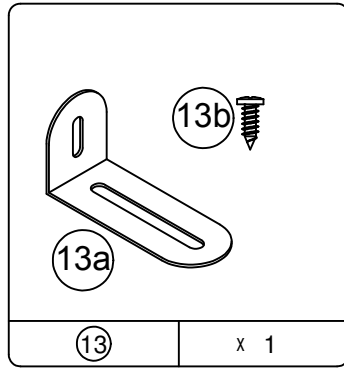
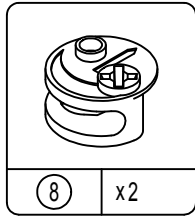
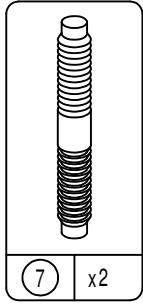

5

**finished edges are facing up
los bordes acabados se vean hacia arriba**

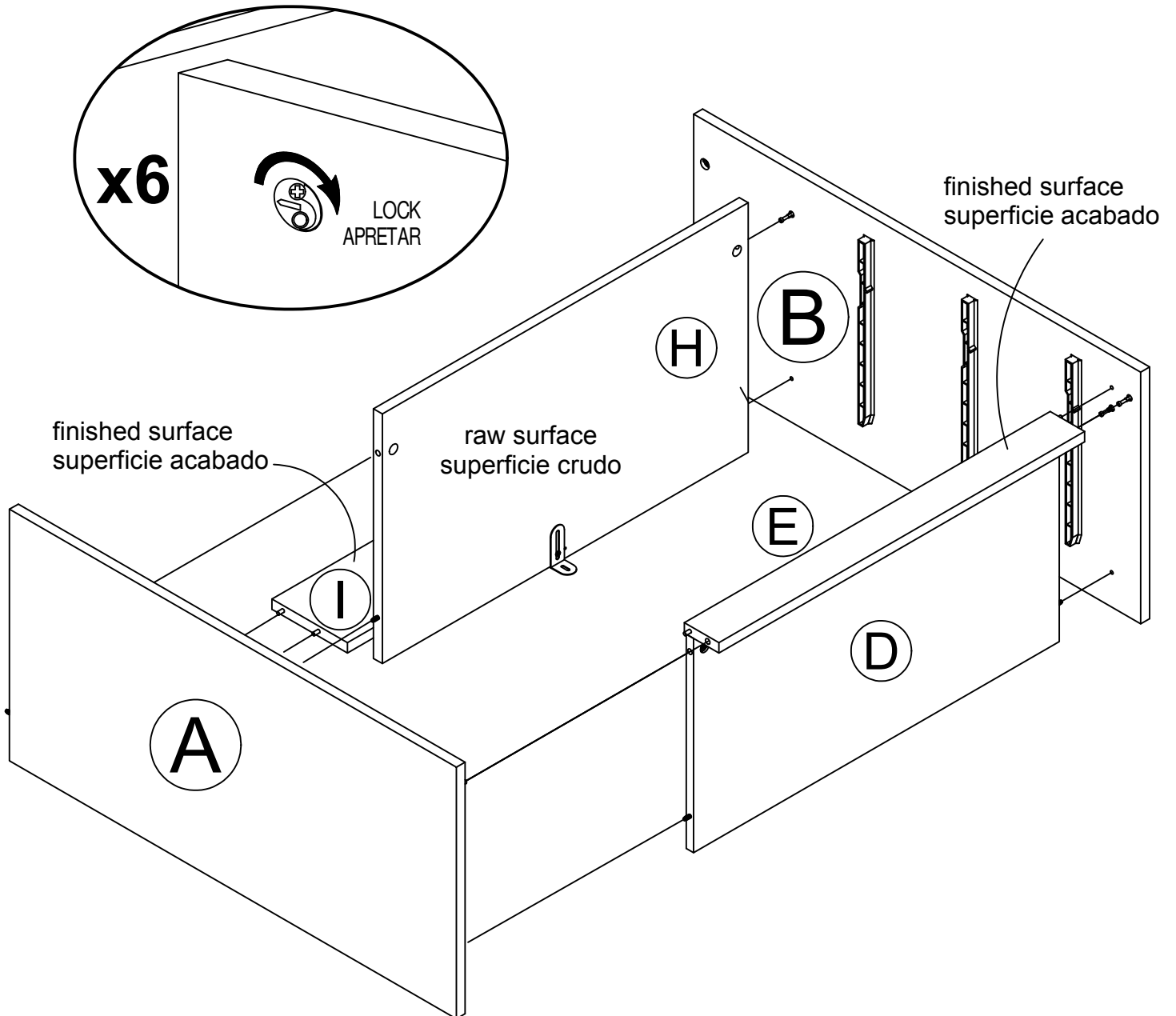

6

finished edges are facing up
los bordes acabados se vean hacia arriba

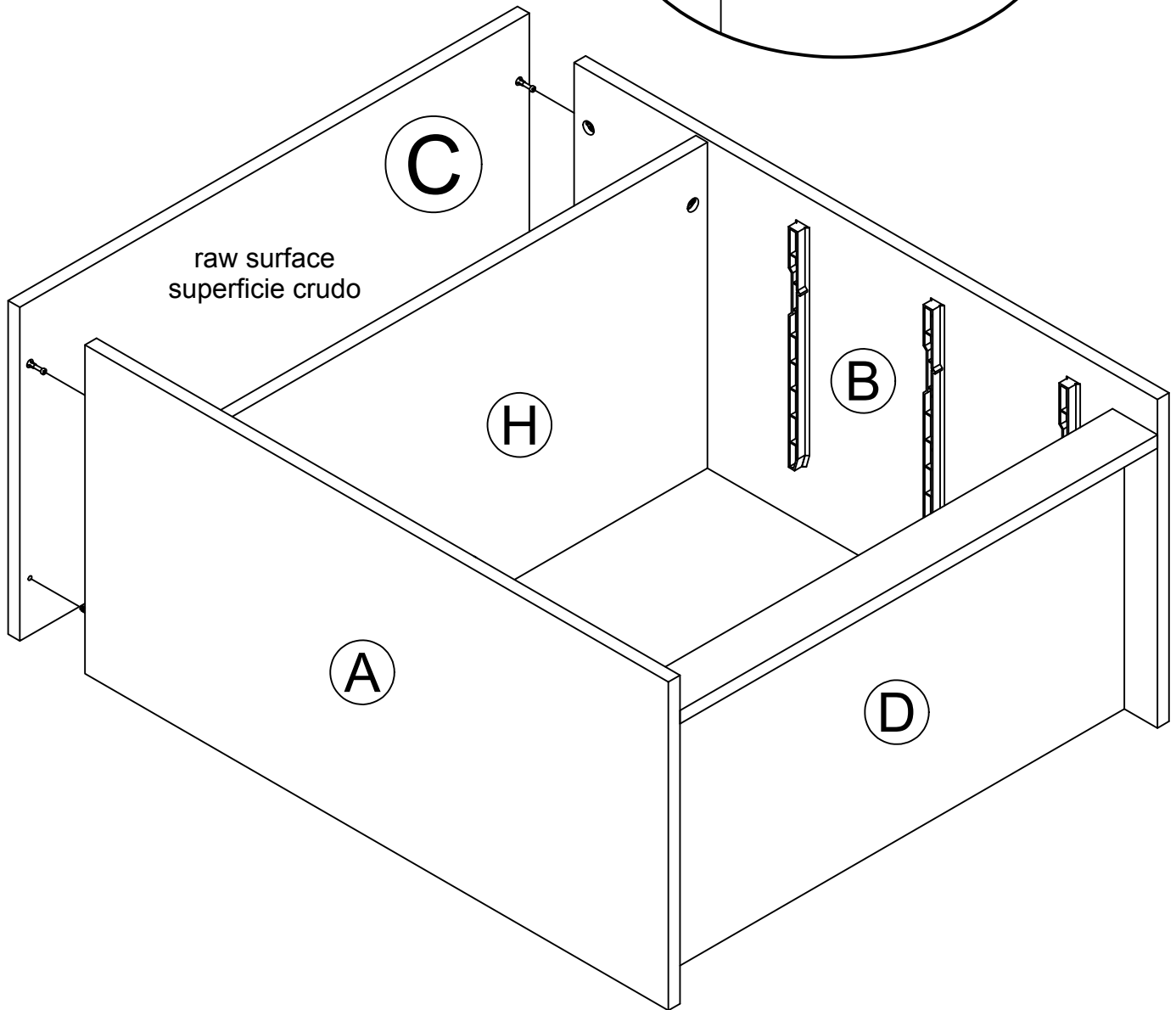
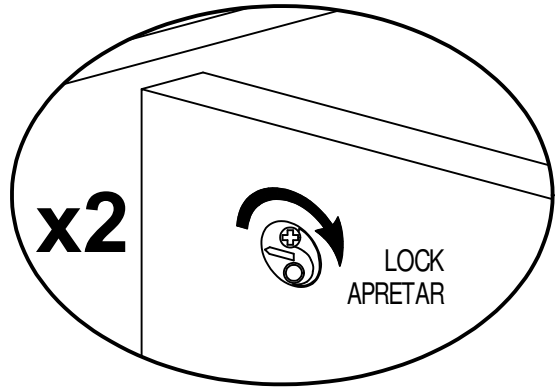

7

place the unit onto its finished edges
coloque la unidad sobre los bordes acabados

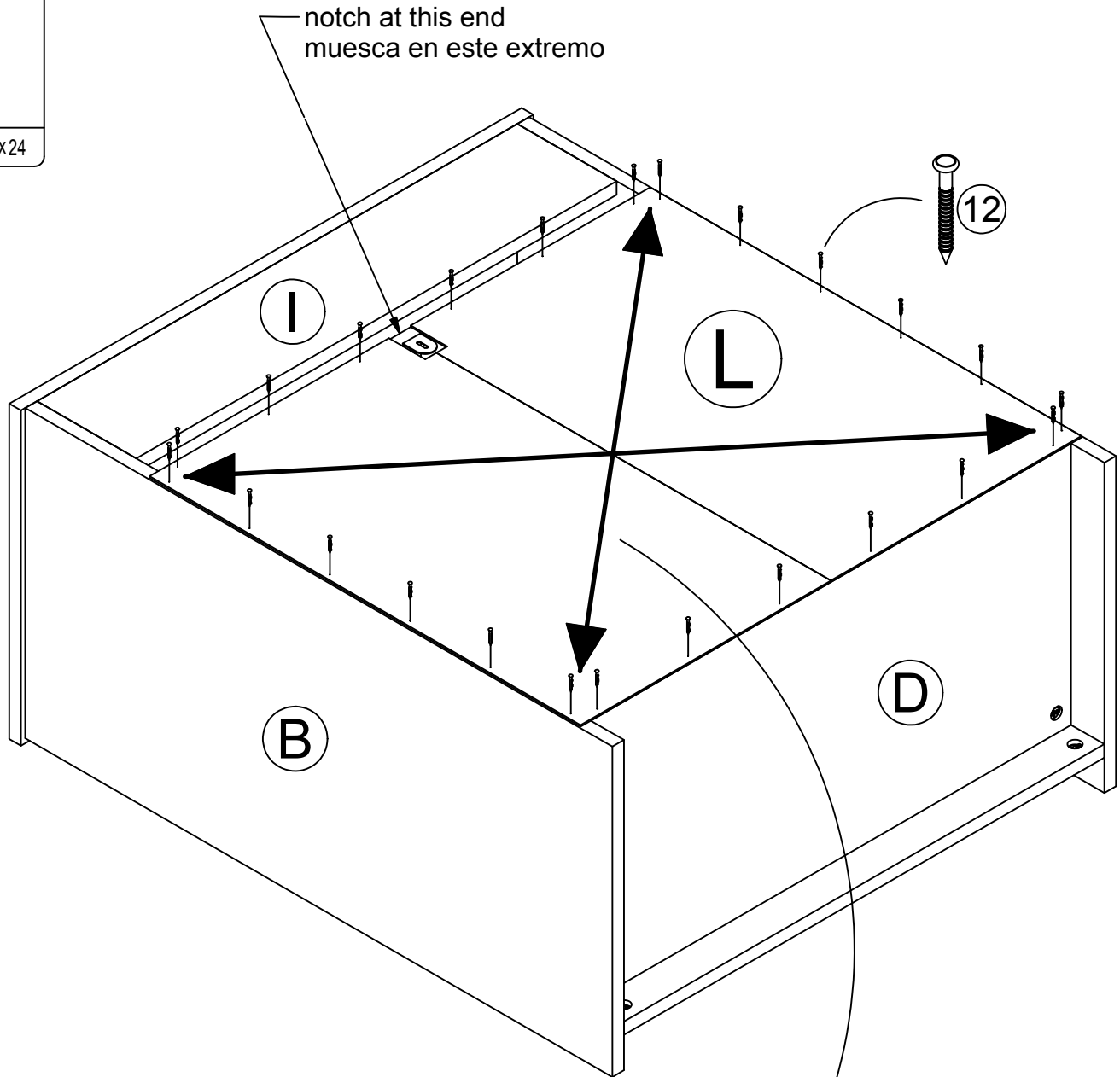
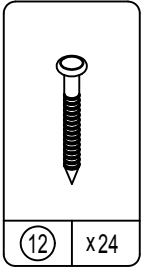

⚠ WARNING

Please make sure that the back panel is attached securely. All nails must be driven into the parts straight. Failure to do so could cause instability, product collapse, and/or serious injury.

⚠ ADVERTENCIA

Por favor asegúrese que el panel trasero es atado firmemente. Todos los clavos deben manejarse en las partes recto y firmemente. El fracaso para hacer para que podría causar inestabilidad, derrumbamiento del producto, y/o la lesión seria.

Make sure that the unit is square.
Distance from corner to corner must be equal.
Asegura la unidad es cuadrada.
Distancia de esquina a esquina deben ser iguales.

8

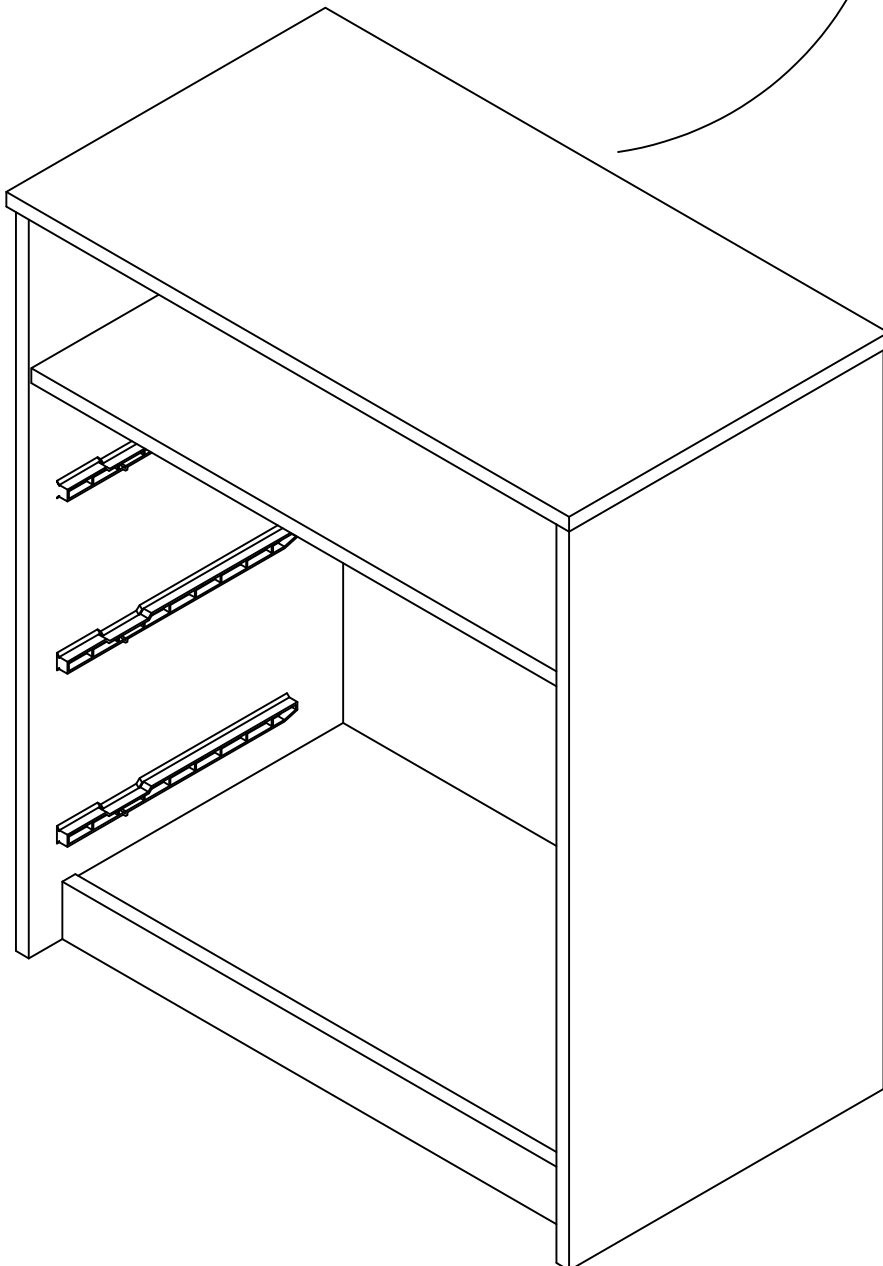
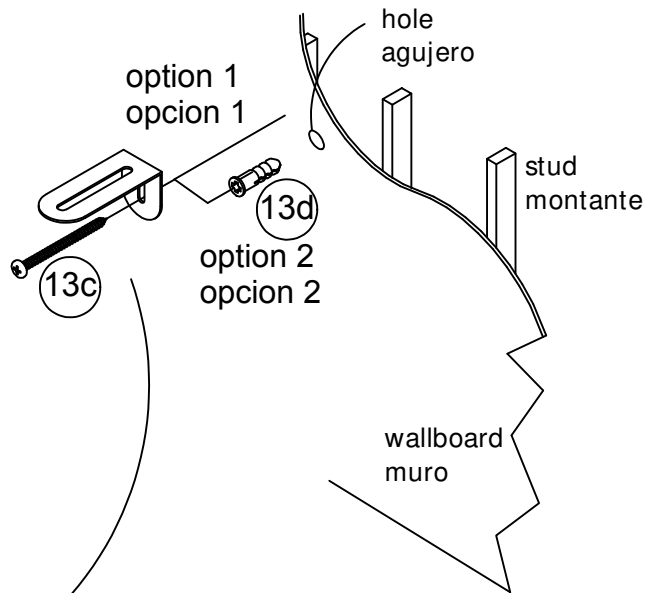
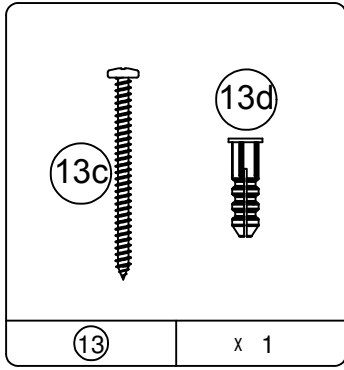

Option 1:

Securely screw (13c) into solid area of the wall as shown.

Opción 1:

Atornille firmemente el tornillo (13c) en el área sólida de la pared como mostrado.

Option 2:

Drill a 3/16" diameter hole (5mm) in the wallboard. Tap the wall anchor (13d) into the hole until it is flush. Fasten the wall bracket (13a) to the wall anchor (13d) with the screw (13c).

Opción 2:

Taladre un agujero de 3/16" de diámetro (5mm) en la pared. Golpea la ancla de pared (13d) en el agujero hasta que sea parejo. Abroche la escuadra de pared (13a) al la ancla de la pared (13d) con el tornillo (13c).

9

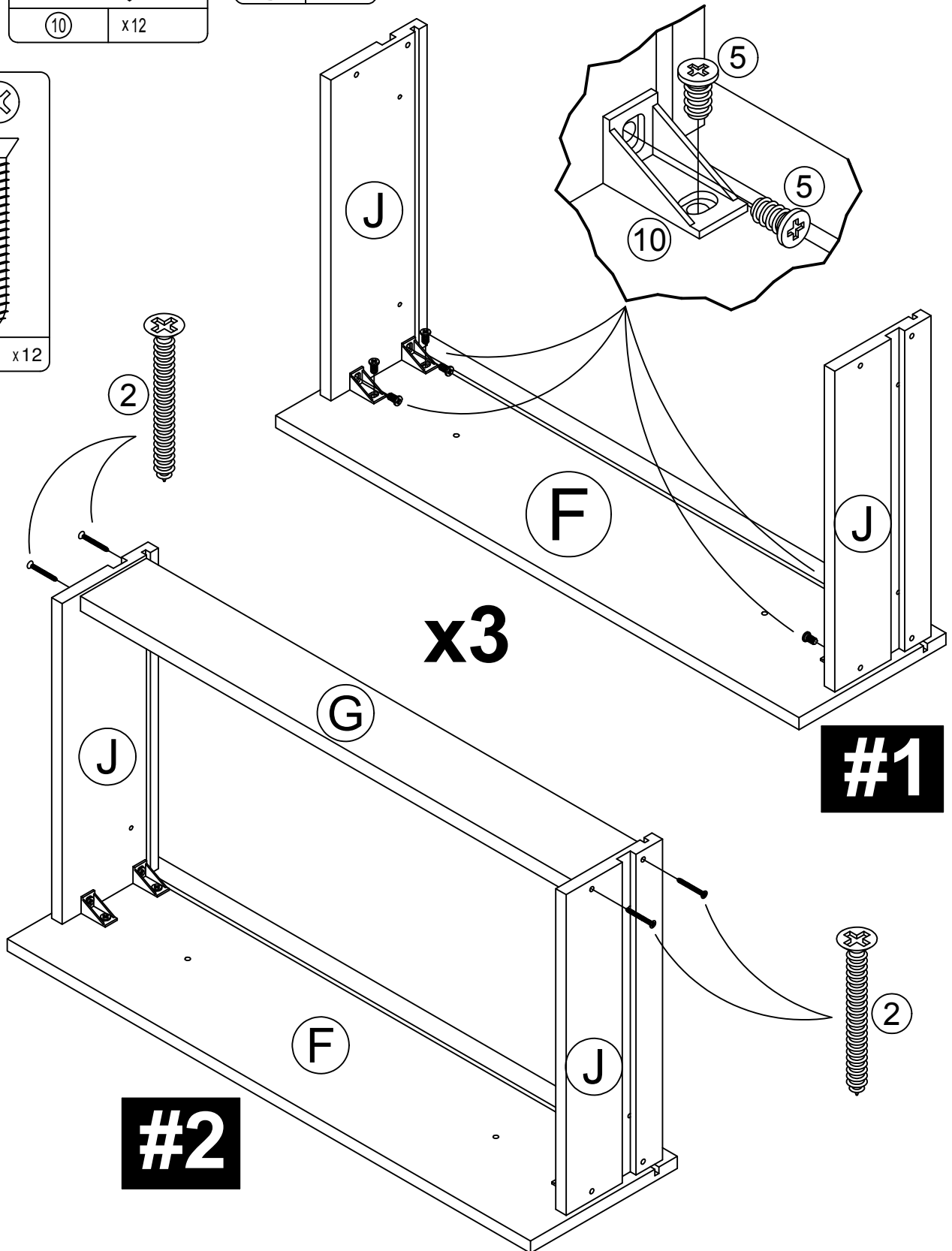
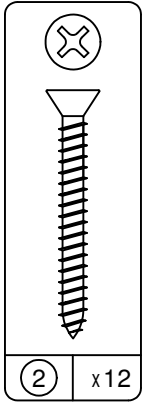
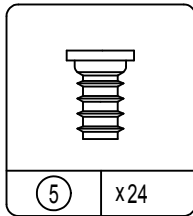
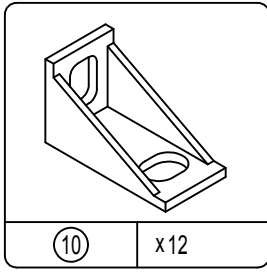

10

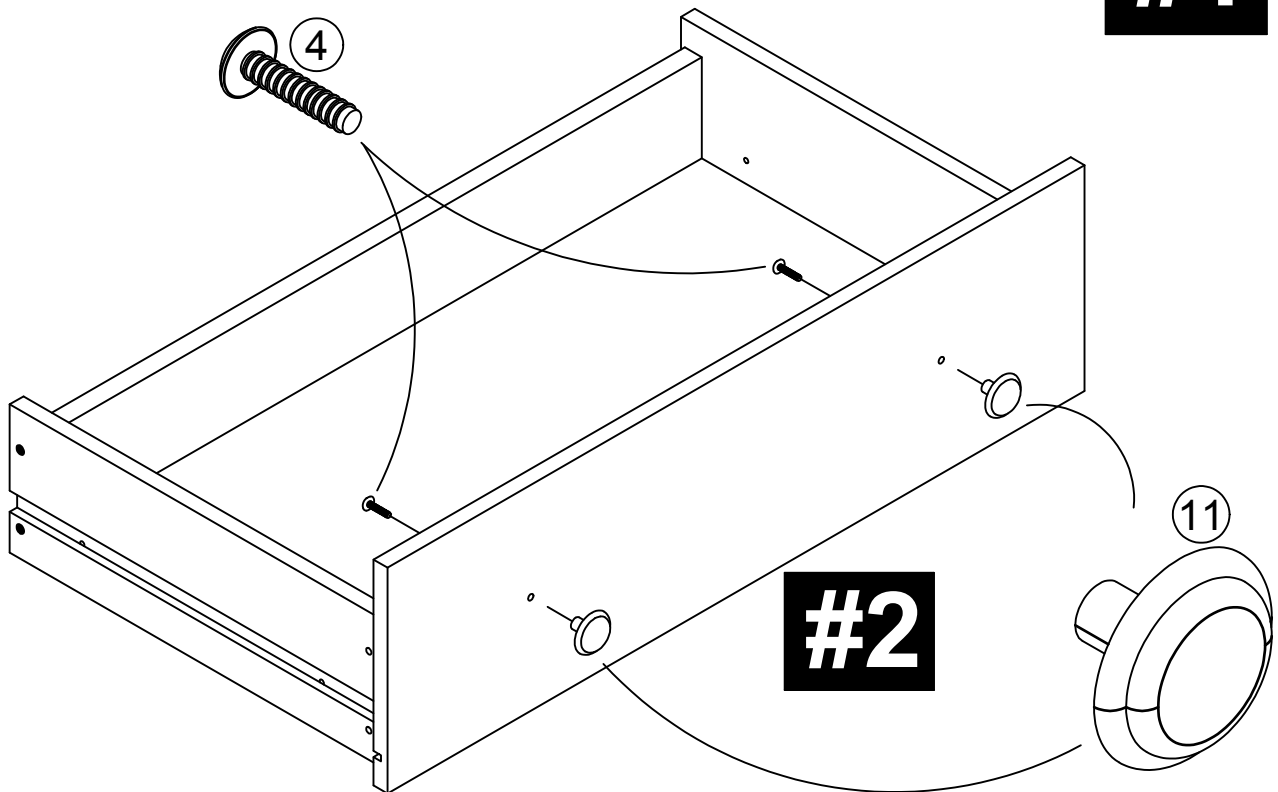
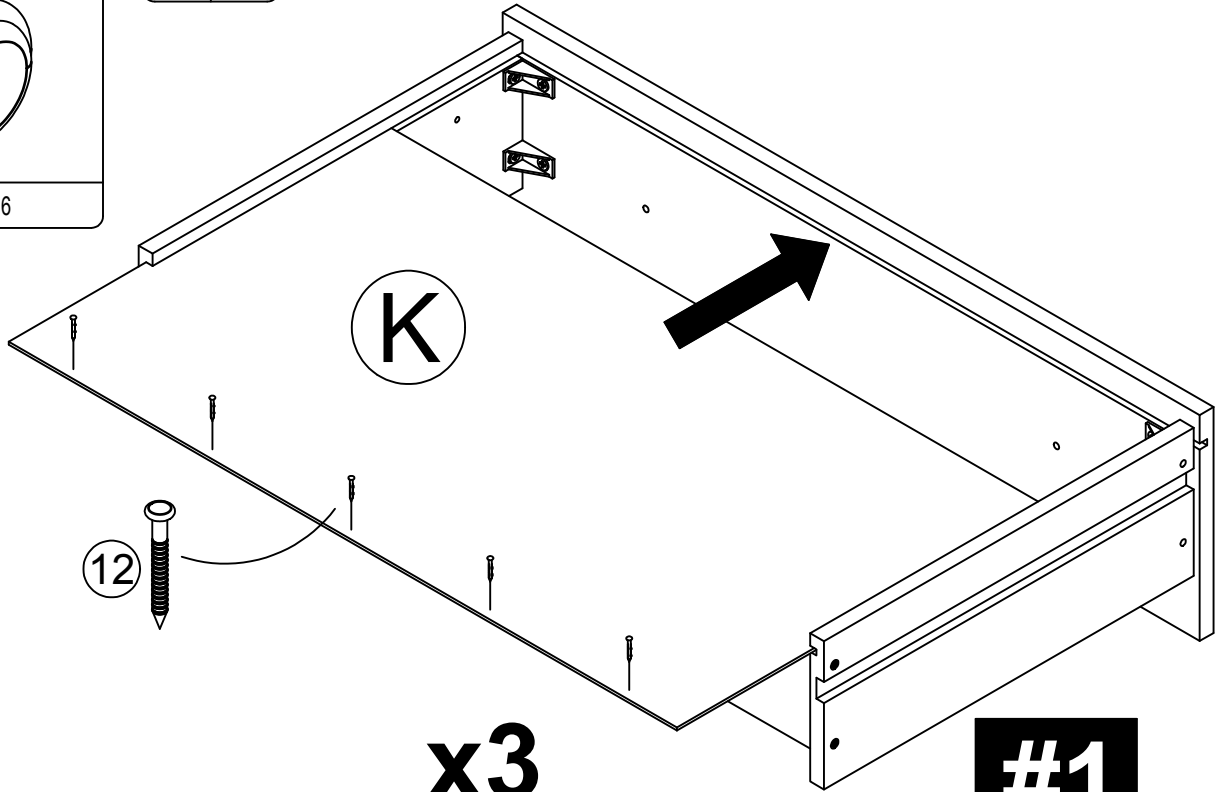
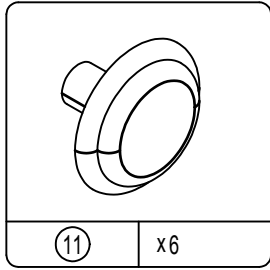
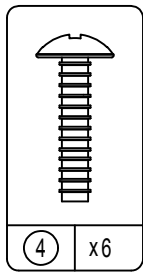
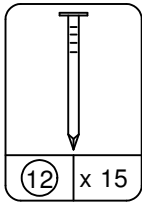

11

Slide the drawers onto the drawer runners 2/3 of the way and insert the stopper pins into the drawer sides.

Deslice los cajones en los corredores del cajón 2/3 de la manera y inserte los pasadores de tope en los lados del cajón.

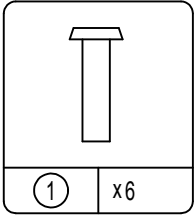

stopper pins are located at the end of the drawer runners
los pasadores de tope se localizan a la extremidad de los correderas de cajón

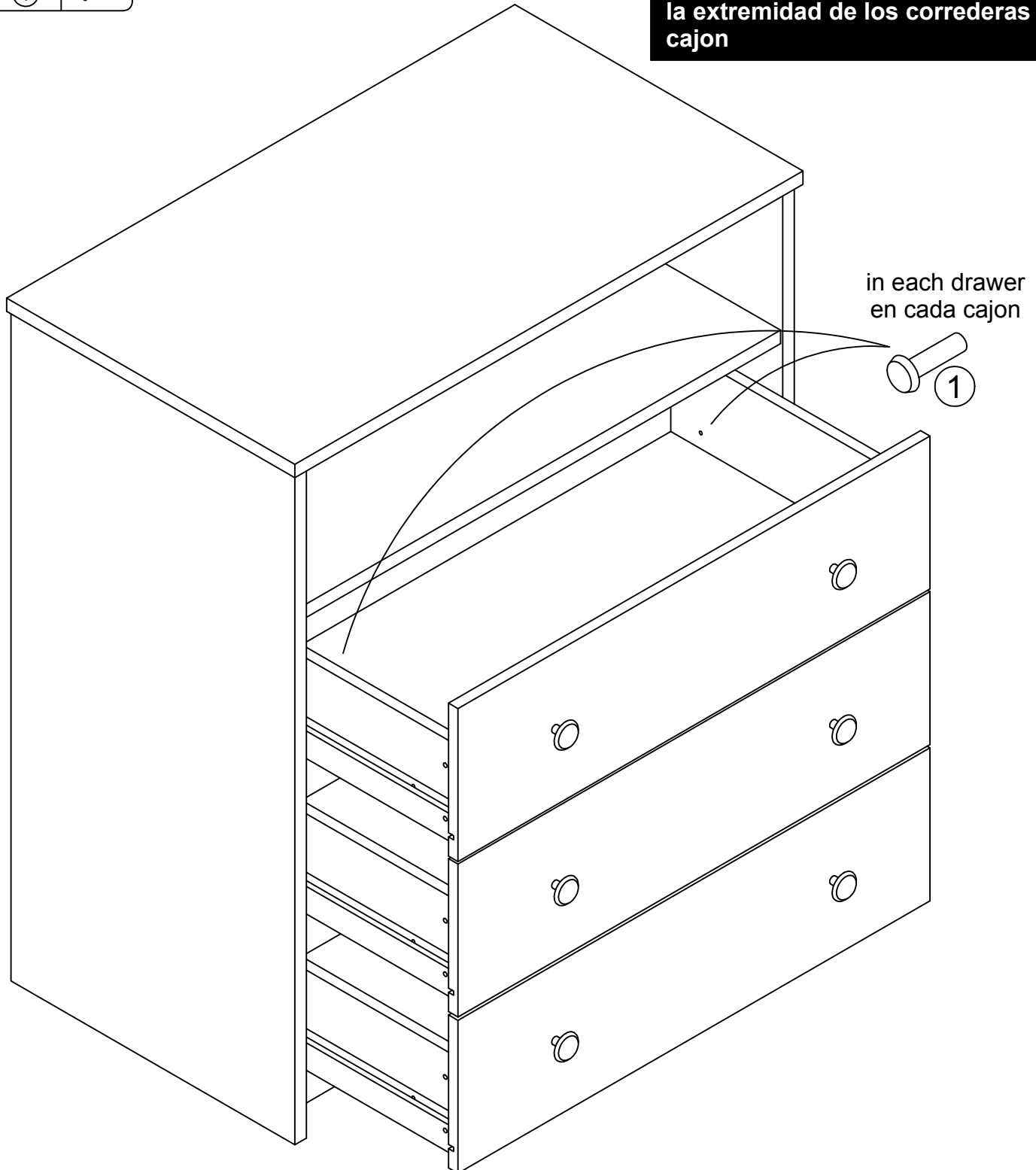

MAXIMUM LOADS – CARGA MAXIMA - CHARGES MAXIMALES

This unit has been designed to support the maximum loads shown. Exceeding these load limits could cause sagging, instability, product collapse, and/or serious injury.

Esta unidad ha sido diseñada para soportar la carga máxima anotada. El exceder estos límites puede causar inestabilidad, colapsarse y/o causar serias lesiones.

Apply the TV warning label (14) onto the top where the base of the TV will cover it.

Aplica la etiqueta de advertencia de TV (14) en la parte superior donde la base de la TV lo cubrirá.

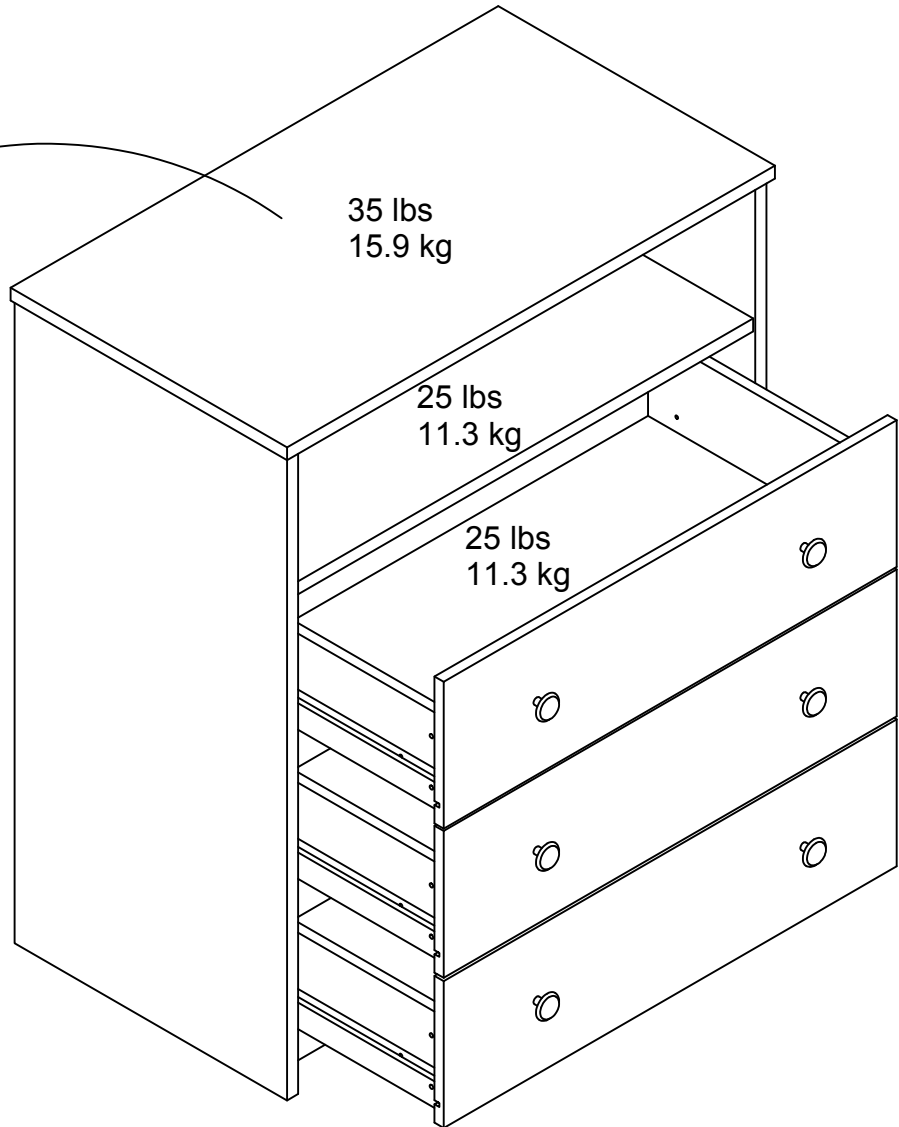

Certificate of Conformity

1. This certificate applies to the Ameriwood Industries Inc. product identified by this instruction manual.
2. This certificate applies to compliance of this product with the CPSC Ban on Lead-Containing Paint (16 CFR 1303).
3. This product is distributed by: Ameriwood Industries Inc.
410 East First Street South
Wright City, MO 63390
1-636-745-3351
4. Site of Manufacture:
 Cornwall ON
5. See front page of instruction manual for date of manufacture.