



Ninz s.p.a. Corso Trento, 2/A  
 I-38061 ALA (TN) / ITALY [www.ninz.it](http://www.ninz.it)  
 Tel. + 39 0 464 678300  
 Fax. +39 0 464 679025 [info@ninz.it](mailto:info@ninz.it)

# EXUS LX A

## PANIC EXIT DEVICE for emergency exits

**A077-GB**

5001174 /2- 05/10

*Denomination* **EXUS PANIC EXIT DEVICE**

*Producer* **Ninz s.p.a. Corso Trento, 2/A  
I-38061 ALA (TN) / ITALY**

*Year application  
trademark* **07**



*N° and year of the  
regulation* **EN 1125:2008**

*Certification authority* **0425**

*N° of CE certificate* **1228-CPD-2007**

*Classification* **3 7 7 B 1 3 2 1 A A**

*Commercial codes*

**EXUS LX A**

**art. 4201101.040**

*Classification no.*

- 1<sup>st</sup> Character - grade 3 - Category of use high frequency
- 2<sup>nd</sup> Character - grade 7 - Durability: 200,000 cycles
- 3<sup>rd</sup> Character - grade 7 - Mass of the door: over 200 kg
- 4<sup>th</sup> Character - grade B - Suitable for use on fire/smoke doors
- 5<sup>th</sup> Character - grade 1 - Safety, suitable for evacuation routes
- 6<sup>th</sup> Character - grade 3 - Highly resistant to corrosion 96h
- 7<sup>th</sup> Character - grade 2 - Safety of goods: 1000N
- 8<sup>th</sup> Character - grade 1 - Projection of the bar up to 150 mm
- 9<sup>th</sup> Character - grade A - Type of activation "push-bar"
- 10<sup>th</sup> Character - grade A - Suitable for one- or two-leaf doors

**Suitable for the passive (secondary) leaf of two-leaf door sets up to 1350 x 2880 mm/leaf in size, with a mass of up to 300 kg/leaf, mounted on hinges or pivots, with fire resistance up to EI<sup>2</sup>120 - REI120 and smoke proof. Projection of the bar: 125 mm.**

### SYMBOLS EMPLOYED



#### CAUTION

Indicates a danger that threatens people and/or material goods. Failure to observe the warnings indicated by this symbol may have serious consequences, such as personal injury and property damage.



#### ATTENTION

Indicates a danger that threatens material goods. Failure to observe the warnings indicated by this symbol may result in damage to material goods.



#### NOTICE

Warnings related to important technical aspects.

### PRODUCT DESCRIPTION

Panic exit device for the passive (secondary) leaf of two-leaf door sets located at emergency exits and activated by a push bar. Composed of stainless steel controls, casings and link arms, plus panic safety lock, vertical rods, upper device, upper counterstrike, floor bushing.

**This product does not contain or release any hazardous materials, as per UNI EN regulation 1125 appendix ZA.**

### OPERATION

The EXUS LX A exit bar is does not include external opening controls because it is always used in combination with a second EXUS LX on the active (principal) leaf.

From the push side, opening is possible at any time by pushing on the horizontal bar, which causes the vertical rods to retract and pulls back the latch bolt of active leaf's latch mechanism, unlatching both doors.

### WARNINGS

**EXUS panic exit devices activated by horizontal push bars are intended for use on doors with lock mechanisms at emergency exits in areas where panic situations could develop.**

**The safety features of this product are of fundamental importance to ensure its conformity with EN 1125. It is strictly forbidden to introduce any type of modifications apart from those described in the instructions below.**

### RECOMMENDATIONS

For the panic exit device to ensure high levels of personal safety and appropriate safety levels for material goods, it should only be mounted on doors and doorframes that are in good condition. The door itself, therefore, should be checked to ensure that it was installed properly and that nothing obstructs its normal movement.

If door gaskets have been mounted on the door, make sure they do not inhibit proper functioning of the panic exit device.



It is essential to check that each leaf opens when its respective panic exit device is activated, and that both leaves open freely when the bars are activated simultaneously.

The fastening instructions in the present document should be followed scrupulously during installation. Once installation is complete, the installer must give this document to the owner of the activity.

The bar should be installed in a way that maximizes its useable length.

For securing the door in the closed position, do not employ any latching devices other than those specified in the present document. This does not preclude the installation of automatic closing devices.

The EXUS panic exit device is also designed for installation on hollow metal doors with an internal cell structure.

If a 'door closer' is needed to return the door to the closed position, care should be taken not to make the opening step more difficult for children, the elderly and the disabled.

A pictogram (arrow) should be positioned immediately above the activation bar on the internal side of the door.



**All of the included components described herein must be positioned and mounted in conformity with the present document.**

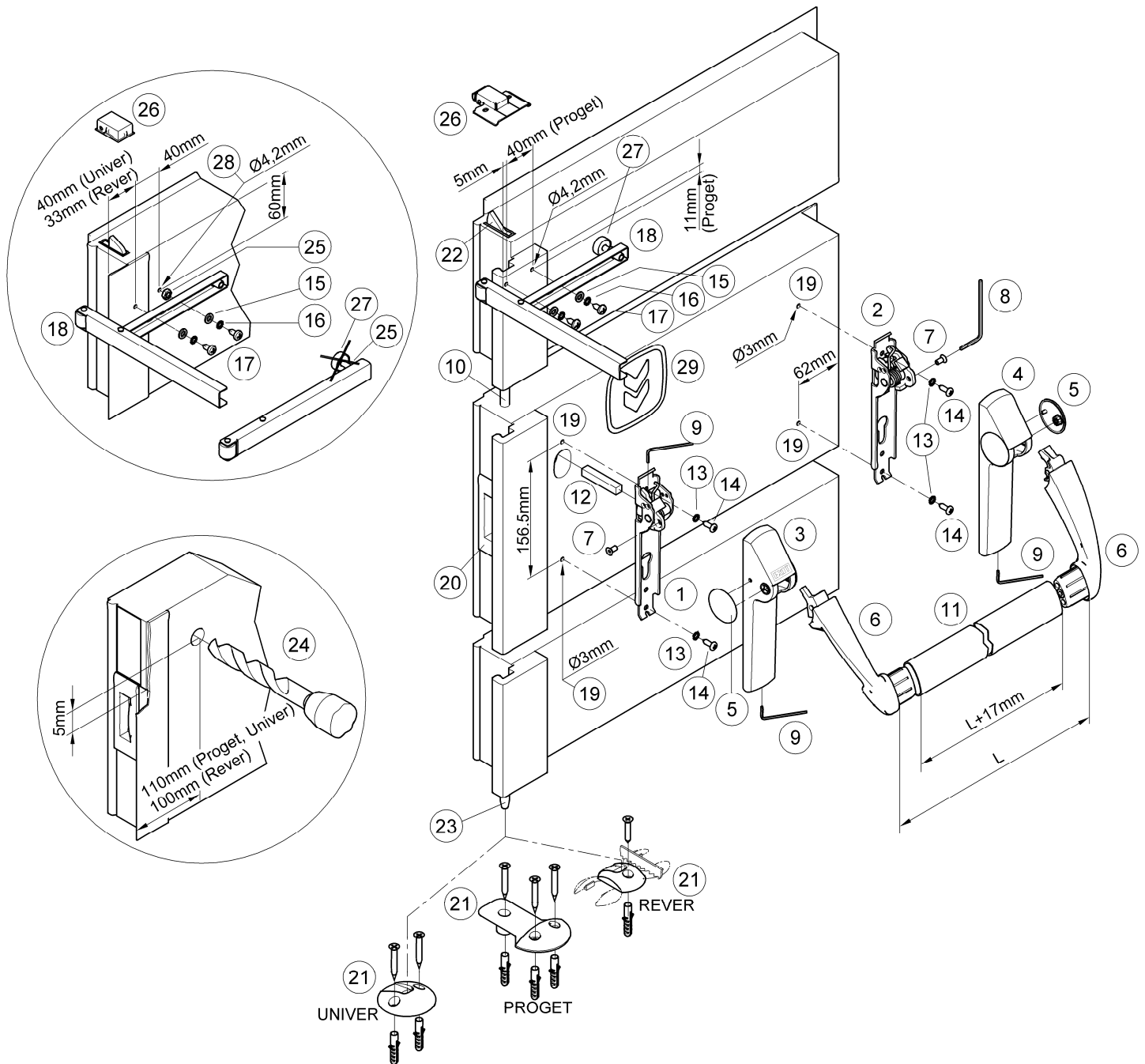

### CONTENTS OF THE EXUS LX A EXIT BAR PACKAGE

Position	pz	Description	Position	pz	Description
1, 2	01	Exus LX mechanism assembly	15	02	Washer
3, 4, 5	01	Exus LX casing package with plugs	16	02	Toothed washer
6	01	EXUS lever-arm package	17	02	Self-tapping screws with cylindrical heads, 5.5x13 mm
7	02	M5x10 mm screws, hex socket	18	01	Companion link-arm (for Multipurpose doors by request only - idem pos. 15, 16, 17)
8	01	S3 Hex wrench	21	01	Proget bushing (Counterstrike) and 3 fasteners
9	01	S2 Hex wrench	21	01	Univer bushing (Counterstrike) and 2 fasteners
11	01	Stainless steel bar	21	01	Rever bushing (Counterstrike) and 1 fastener
12	01	Square pivot 9x9x52 mm	29	01	Adhesive pictogram (green arrow)
13	04	Toothed washer	-	01	A034 hole-drilling template
14	04	Self-tapping screws with cylindrical heads, 4.8x16mm	-	01	EXUS LX A Kit exit bar installation instructions



Please note that article 4 of the MD of 03 November 2004 obliges the Installer to write up, sign and provide the owner of the activity with a declaration of proper installation that makes explicit reference to the instructions supplied by the exit device manufacturer.

**N.B.** The door is provided with the safety lock (20), rods (10, 23), upper relatch device (22) and upper counterstrike (26) already installed.



### TOOLS REQUIRED

Medium-sized philips-head screwdriver or electric screwdriver, electric drill with Ø 3 mm, Ø 4,2 mm and Ø 20 mm drill bits for steel, hack-saw for stainless steel.

## IMPORTANT

- Installation should be carried out by qualified personnel only and in strict conformity with the instructions supplied below.
- Proper installation incorporates all supplied components, including the toothed washers.
-  • No variations are allowed, and only components indicated in the package contents may be used.
- Given its function, the EXUS LX A panic exit device should only be mounted on the push side of the passive leaf and always be combined with the panic exit device of the active leaf.
- Prior to assembly, check all the contents of the package.
- Check whether the panic safety lock on the passive leaf was applied in the right direction.
- The only installation configurations that may be used are described in the outline on pages 2-4.
- Ensure that the main leaf is also equipped with the EXUS LX panic exit device.

## INSTALLATION

- If not already installed, apply the floor-mounted bushing (21) by attaching it with the appropriate screws and fasteners according to the door installation instructions.
- Proceed with assembly of the exit bar. If no hole is present for passage of the follower, drill the hole in the metal panel from the push side of the door using the Ø 20 mm drill bit, positioning it as indicated in the figure (24).
- Level the template and drill the holes (19) using the Ø 3 mm drill bit, drilling the internal reinforcement as well.
-  - Insert the follower (12) on the control mechanism (1) until it just touches the spring, then block it with the threaded pin and tighten using the S2 hex wrench (9).
- Apply the mechanism (1) by centering the follower (12) carefully over the hole in the safety lock (20), supporting it against the surface of the door and attaching it with self-tapping screws 4.8x16 mm (14) and their toothed washers (13).
- Fasten the exit bar mechanism (2) at the hinge end using self-tapping screws 4.8x16mm (14) and their toothed washers (13).
- Apply the casing (3) to the mechanism (1) after removing the externally-facing plug (5). To do this, insert a finger inside the casing and push the plug out, being careful not to remove the plastic insert. Repeat the same operation with the casing (4) and the mechanism (2). Do not fasten the pins, so as to leave some play in the two casings.
- Apply the link arms (6) and fasten them with the dedicated screws (7), securing them with the included S3 wrench (8).
- Make a precise "L" measurement and cut the stainless steel bar (11), adding 17 mm; remove the burs from the bar; remove one link arm, attach the bar and re-fasten the assembly.
- Finish fastening the casings (3) and (4), using the wrench (9) to screw in the pins without using excess force, then apply the plugs (5).
- Apply the companion link arm (18) as shown in the drawing, fastening it with two self-tapping screws 5.5x13 mm (17) and their washers (15 and 16).
- For PROGET doors, the holes for the link arm are already provided, simply regulate the rubber spacer (27) so that it rests properly on the leaf.
- For UNIVER and REVER doors, alternatively, drill 2 holes (28) with the Ø 4.2 mm drill bit 60 mm away from the upper rabbet of the leaf and 40 mm apart. For UNIVER doors, the first hole should be made 40 mm from the lateral edge of the centerpost, while for Rever doors the distance is 33 mm.
- For UNIVER and REVER doors, unscrew the rubber spacer (27) and keep the nut (25), which will serve as a spacer for attaching the link arm through the third slot.
- Adjust the position of the companion link arm so that it acts on the exit bar of the passive leaf. The active leaf is pushed just enough to ensure the correct closing sequence for the two leaves (active leaf held in waiting position by the closing regulator).
-  - Activate the EXUS LX A exit device at any point along the horizontal bar and check for the complete exit of the counter-latchbolt and full retraction of the relatch device (22) and lower rod (23). Test the system with the doors open and closed. For fire doors, verify that the self-closing sequence of the two leaves functions properly.



- Apply the pictogram (29) with the green arrow on the internal surface of the door, just above the activation bar.
  - Lastly, use a dynamometer to measure the force required on the horizontal bar of the EXUS LX A bar to free the passive leaf from the latch bolt of the latch mechanism and the upper and lower latches. Record this force measurement in the present document.

## USE

- Ensure that the door always opens easily.
- Avoid unnecessary strains on or handling of the exit bar.
- Protect the exit bar from external atmospheric agents.
- Ensure that nothing obstructs free movement of the exit bar.
- Do not paint the safety lock or the upper and lower latch devices.
- Use the bar properly, do not pull it in the wrong direction.
-  • Make sure that any damaged or malfunctioning parts are replaced immediately.

## MAINTENANCE

To ensure that door usage conforms with regulations, the following maintenance checks should be carried out at least once a month:

- Confirm that all of the installed components correspond with those listed in the present instructions, and that no latching devices other than those originally installed have been added to the door.
- Inspect and activate the panic exit device to verify that all of its components are in satisfactory operational condition.
- Use a dynamometer to confirm that the release force shows no significant differences from the forces recorded at the time of installation.
-  - Check whether all screws are fully tightened, tightening any that may have loosened.
- Activate the EXUS LX A panic exit device by pushing it all the way down at any point along the horizontal bar in order to verify that the counter-latchbolt of the latch mechanism comes completely out, and that the upper relatch device (22) and the lower rod (23) retract all the way. Test the system with the doors open and closed.
- Check whether the counter-latchbolt fully re-inserts upon release of the exit bar, and that the upper device and lower rod come completely out.
- For fire doors, open the two leaves by activating the exit bar of the secondary leaf, then confirm the correct closing sequence of the two doors.
- Check the stainless steel bar and replace it if any damage or deformities are detected.
-  - Ensure that the upper and floor-mounted counterstrikes are not blocked; if so, remove the obstruction.
- The product requires no special maintenance. Grease spray should be used to lubricate the upper relatch device, the lower rod guide, internal workings of the safety lock and the exit bar on a regular basis - the latter has a hole on the underside of its casing for this purpose.
- For normal cleaning, use a cleaning agent designed specifically for stainless steel.

 **Any adjustments that become necessary must be carried out by qualified personnel using original NINZ replacement parts.**

 **The owner of the activity is responsible for keeping the declaration of correct installation on file, conducting proper exit bar maintenance in accordance with all of the manufacturer's maintenance guidelines, keeping maintenance and check-up records and preserving the present document.**

 <b>ATTESTATO DI CONFORMITÀ</b> DIRETTIVA 89/106/CEE <b>CERTIFICATE OF CONFORMITY</b> DIRECTIVE 89/106/CEE		 0425
<small>Questo certificato è rilasciato in conformità a quanto prescritto dall'Art.6 par.2 lettera b) del DPR 21 aprile 1993, n°246 (Direttiva 89/106/CEE) ed attesta la conformità del prodotto di seguito identificato agli Art.1, Art.2 ed allegato A del DPR 21 aprile 1993, n°246 (Direttiva 89/106/CEE)          This certificate has been issued in conformity to what prescribed by the Art.6 par.2 letter b) of the DPR 21/04/1993, n°246 (Directive 89/106/EEC) and certifies the conformity of the product described below to the Art.1, Art.2 and attachment A of DPR 21/04/1993, n°246 (Directive 89/106/EEC)</small>		
<b>ATTESTATO N°</b>	<b>1228 - CPD - 2007</b>	<b>CERTIFICATE N°</b>
<b>Organismo notificato</b>	<b>ICIM S.p.A. - Piazza Don Mapelli, 75 - 20099 Sesto San Giovanni (MI) ITALY</b>	<b>Notified Body</b> Identification number: 0425
<b>Dati Fabbricante</b>	<b>NINZ S.p.A. Corso Trento, 2/A - 38061 ALA (TN) ITALY</b>	<b>Manufacturer</b> Head office Operative unit
<b>Dati prodotto</b>	<b>Product</b>	
Tipologia	DISPOSITIVI ANTIPANICO PER USCITE DI SICUREZZA AZIONATI MEDIANTE UNA BARRA ORIZZONTALE <b>PANIC EXIT DEVICES</b>	
Denominazione	Dispositivo antipatico serie "TWIST" "EXUS LP" "EXUS LA" "EXUS LX".	Denomination
	Serrature antipatico art. AP1618, SCA 1 3201001.019020, MAC 1 3201001.041042, 4506002.17 (V), 3201001.018, 485-65-0.	
	Controserrature antipatico art. AP020P, AP020U, 4506002.18 (V), 3201001.6, 43190-85.	
	Dispositivo superiore art. 3105080, 3105024, 4506003 (V), 3305003.	
	Riscontro asta art. 2401036, 2401046, 2401044, 4506005 (V), 2401002.	
	Boccola pavimento art. 2401001, 2401007, 3105091, 4509006 (V), 2401020, 4419008.	
	Deviatori art. 4201010.	
	Aste verticali art. 3305015, 3305016, 3305002, 4509003 (V), 3305013, 990637.	
	Riscontro serratura art. 2401005, 2401005, 2401015, 2401014, 4506006 (V), 2401005, 2401035, 3412001.	
	Comandi esterni art. BM, BSP, BS, BMC, BC, B, A, BM alu, BM inox, BSP inox, BSP alu.	
Sistema di attestazione della conformità	1	Attestation of conformity
Norma di riferimento	EN1125:2008	Standard
Classificazione	3   7   7   B   1   3   2   1   A   A	Classification
<b>Eventuali estensioni</b>	<b>Nessuna / None</b>	<b>Extensions</b>
<b>Eventuali condizioni di subordinazione della Certificazione CE</b>	<b>Nessuna / None</b>	<b>Possible conditions of subordination of the CE Certification</b>
<small>Il presente attestato è valido esclusivamente per il prodotto indicato. Eventuali varianti da apportare devono essere approvate da ICIM S.p.A.          The present issue is valid only for the product described above. Possible changes to be brought in have to be approved by ICIM S.p.A.</small>		
<b>Data di emissione</b> First issue	<b>Emissione corrente</b> Current issue	<b>Data di scadenza</b> Expiring date
18/04/2007	04/08/2010	17/04/2017
		 ICIM S.p.A. Il Presidente Ing. Tullio Badino

REPLACEMENT PARTS (see expanded drawing, pages 2-4)		
Position	Code	Description
1, 2, 3, 4, 5, 6, 7, 8, 29	3102061	Exus LX Base
1, 2	3105127	Stainless steel Exus mechanism assembly
3, 4, 5	3105163	Exus LX casing package with plugs
6	3105140	Exus LX lever-arm package
7, 8	3105026	Exus LX bag
11	4204016	Stainless steel bar package
9, 12, 13, 14, 21	4211101.041	Twist/Exus Proget package A
9, 12, 13, 14, 21	4211101.042	Twist/Exus Univer package A
9, 12, 13, 14, 21	4211101.043	Twist/Exus Rever package A
20	3201001.024	AP020P Panic safety lock for Proget and Univer fire doors
20	3201001.008	AP020U Panic safety lock for Rever and Univer multipurpose doors
22	3105080	Proget relatch device
22	3105024	Univer and Rever relatch device
10	3305015	Proget, Univer and Rever upper rod
23	3305016	Proget lower rod
23	3305002	Univer and Rever lower rod
26	2401046	Proget upper counterstrike
26	2401044	Univer and Rever upper counterstrike
15, 16, 17, 18	3305001	Companion link arm with washers and screws



**ANY REPLACEMENTS MUST USE ORIGINAL NINZ REPLACEMENT PARTS FROM ITS FULL CERTIFIED SYSTEM!**

### Certified EXUS LX A components

Panic exit device series:

"EXUS LX A"

Panic safety lock devices: art. AP020P, AP020U  
 Upper device: art. 3105080, 3105024  
 Rod counterstrike: art. 2401036, 2401046, 2401044  
 Floor-mounted bushing: art. 2401001, 2401007, 3105091  
 Vertical rods: art. 3305015, 3305016, 3305002  
 Safety lock controls: art. A

### PROPER DISASSEMBLY

When some or all of the bar needs to be replaced, the general approach is to reverse the order of the original installation instructions. Replacement of rods and/or the upper device first requires that the safety lock be disassembled. Replacement of the safety lock first requires that all parts of the exit bar in the latch mechanism zone be disassembled. The safety lock (20) can be disassembled by unscrewing the 2 frontal screws, first detach the heat-expanding seal that is glued over the fastener screws (only for fire doors).



The operation should be carried out with great care, being sure not to ruin or displace any of the components inside the safety lock housing, and re-attaching the rods with great care!

### MAINTENANCE RECORD

Date	Description of intervention	Release force checked	Operator
_____	_____	_____	_____
_____	_____	_____	_____
_____	_____	_____	_____
_____	_____	_____	_____
_____	_____	_____	_____
_____	_____	_____	_____



These instructions should be given to the owner of the activity, who shall preserve them as a record of the maintenance operations carried out on the panic exit device.