

GENERAL NOTES:

1. DIMENSIONS
  - SHOWN IN INCHES W/ MM EQUIVALENTS IN BRACKETS
  - OVERALL LENGTH = CENTERS + FLOAT LENGTH + 2 \* MATING FLANGE THICKNESS + 6.25" [159]
2. OPERATING CONDITIONS
  - MAX PRESSURE, MAX TEMPERATURE, & MIN SPECIFIC GRAVITY REQUIRED FOR PROPER GAGE DESIGN
3. PART NUMBER
  - CONSULT "MAGNICATOR® II MAGNETIC LIQUID LEVEL INDICATION PRODUCTS" (BULLETIN M100.01) FOR COMPLETE PART NUMBER DETAILS & LIST OF AVAILABLE OPTIONS
4. STANDPIPE SIZE
  - 2 1/2" [65] SCH. 40 (STANDARD)
  - CONSULT FACTORY FOR OPTIONAL STANDPIPE SIZE AND/OR SCHEDULE (DEPENDENT ON OPERATING CONDITIONS)
5. MATERIALS OF CONSTRUCTION
  - 304/304LSS W/ CS TRIM (FLANGES, BOLTING, & PLUGS) (STANDARD)
  - 316/316LSS W/ CS TRIM (FLANGES, BOLTING, & PLUGS) (STANDARD)
  - ALL 304/304LSS (316SS BOLTING) (STANDARD)
  - ALL 316/316LSS (316SS BOLTING) (STANDARD)
  - CONSULT "MAGNICATOR® II MAGNETIC LIQUID LEVEL INDICATION PRODUCTS" (BULLETIN M100.01) FOR A COMPLETE LIST OF AVAILABLE MATERIALS
6. FLOAT MATERIALS
  - 316LSS (STANDARD)
  - TITANIUM (STANDARD)
  - MONEL 400
  - HASTELLOY C276
7. FLOAT LENGTHS
  - 12" [305] (STANDARD)
  - 17" [432] (STANDARD)
  - 22" [559] (STANDARD)
  - LENGTHS DEPENDENT ON OPERATING CONDITIONS
  - CONSULT FACTORY FOR CUSTOM LENGTHS
8. GASKET MATERIALS
  - FLEXITALLIC "CGI" (OR EQUAL) SPIRAL-WOUND (STANDARD) W/ CS OUTER RING, 304 OR 316SS INNER RING, & GRAPHITE FILLER
  - CONSULT FACTORY FOR OPTIONAL GASKET MATERIALS
9. PROCESS FLANGES
  - 1/2" [15] THRU 1" [25] ANSI/ASME RAISED-FACE SOCKET WELD FLANGES (STANDARD) (MAY REQUIRE INCREASE IN SECTION A-A DIMENSION SHOWN)
  - 1 1/2" [40] THRU 6" [150] ANSI/ASME RAISED-FACE SOCKET WELD FLANGES (REDUCED TO 1") AVAILABLE ON REQUEST (WILL REQUIRE INCREASE IN SECTION A-A DIMENSION SHOWN)
  - RAISED-FACE DIN FLANGES AVAILABLE ON REQUEST
  - (2) SIDE FLANGES (STANDARD)
  - (2+) SIDE FLANGES AVAILABLE ON REQUEST
10. VENT / DRAIN CONNECTIONS
  - 1/2" [15] FNPT (SHOWN) (STANDARD)
  - 1/2" [15] THRU 1 1/2" [40] FNPT, MNPT, FSW, & MSW
  - 1/2" [15] TO 3" [80] RAISED-FACE ANSI/ASME & DIN FLANGED
11. INDICATION
  - YELLOW / BLACK FLAGS IN ALUMINUM HOUSING (SHOWN) (STANDARD)
  - HERMETICALLY-SEALED FLAGS IN POLYCARBONATE TUBE W/ 316SS FRAME (BULLETIN M100.110)
  - HERMETICALLY-SEALED FLAGS IN GLASS TUBE W/ 316SS FRAME (BULLETIN M100.110)
  - NIGHTSTAR™ (ILLUMINATED FLAGS) (120 OR 240 VAC)(BULLETIN M100.140)
  - LEVELSTAR™ (LED ILLUMINATOR) (120 OR 240 VAC)(BULLETIN M100.120)
12. SCALES
  - FEET / INCHES (SHOWN) (STANDARD)
  - METER / CENTIMETER
  - PERCENT
  - CONSULT FACTORY FOR SPECIAL SCALES
13. POINT LEVEL SWITCHES
  - 0 SAS-16 TRI-MAGNET (BULLETIN M100.27)
  - 0 RS-2 (SPDT) HERMETICALLY-SEALED REED (BULLETIN M100.20)
  - 0 RS-2/2 (DPDT) HERMETICALLY-SEALED REED (BULLETIN M100.20)
14. 4-20mA TRANSMITTERS
  - 0 MTII-4200 MAGNETOSTRICTIVE (BULLETIN M100.23)
  - 0 RST2 REED SWITCH (BULLETIN M100.22)

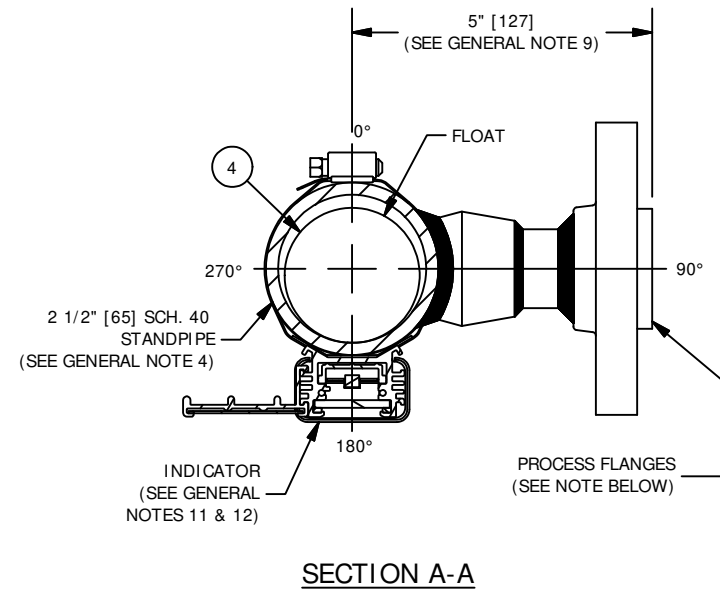
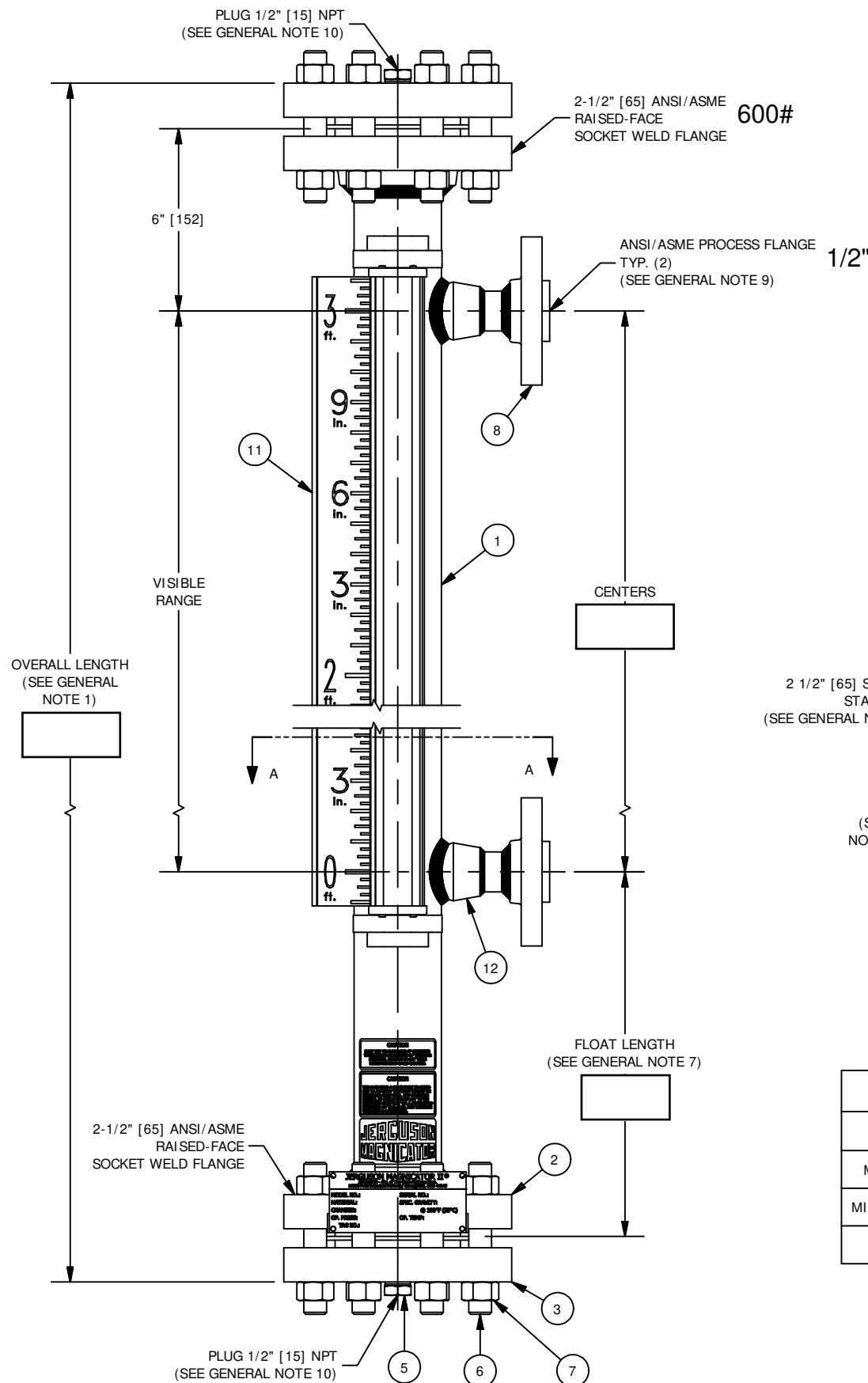

NOTE: AS STANDARD, PROCESS FLANGES WILL BE ORIENTED AT 0°. THEY ARE SHOWN IN THIS DRAWING AT 90° FOR EASE OF VIEWING.

OPERATING CONDITIONS	
MAX PRESSURE	
MAX TEMPERATURE	
MIN SPECIFIC GRAVITY	
PROCESS FLUID	

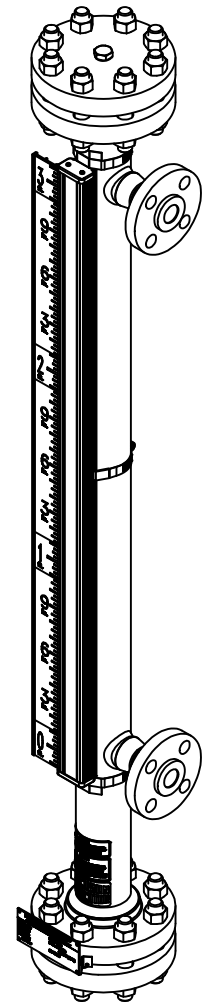

BILL OF MATERIAL

NO.	NAME OF PART	MATERIAL	REMARKS
1	STANDPIPE		
2	FLANGE, SOCKET WELD		
3	FLANGE, THREADED		
4	FLOAT		
5	PLUG		
6	STUD		
7	HEAVY HEX NUT		
8	PROCESS FLANGE		
9	NIPPLE		
10	GASKET		
11	INDICATOR		
12	PIPET, SW		

MANUFACTURED BY  
**Clark-Reliance®**  
 16633 FOLTZ PARKWAY  
 STRONGSVILLE, OH 44149 USA  
 (440) 572-1500 | www.clarkreliance.com  
 © Clark-Reliance® Corporation. All Rights Reserved.

**JERGUSON®**  
 MODEL MIIH-ESF  
 MAGNICATOR II  
 (W/ 600-2500# ANSI/ASME FLANGES)

DRAWN: TJB  
 CHECKED: MK  
 DATE: 4/8/2013  
 REVISION: 2  
 DRAWING NO.: **MIIH-ESF6**  
 REV.: **2**