



F1200 + BNK

VERTICAL FORM, FILL AND
SEAL PACKAGING MACHINE



ESSE GI F1200 + BNK

DIMENSIONS

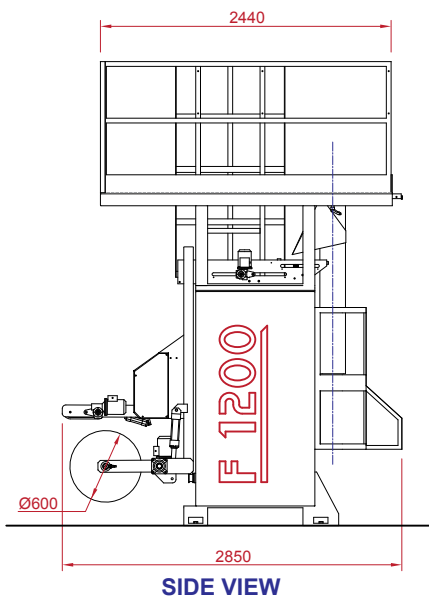
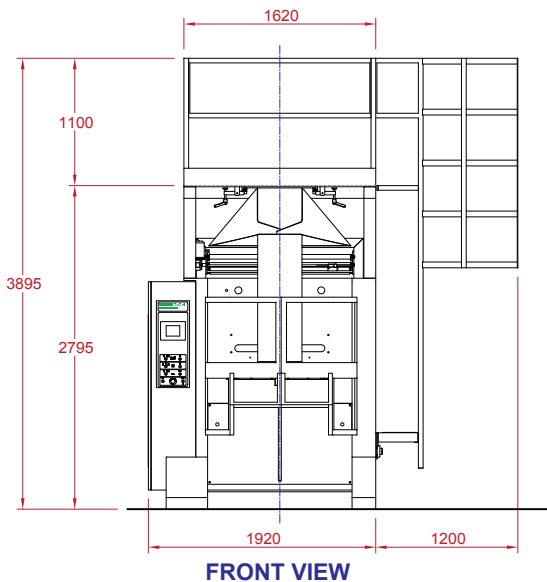

TECHNICAL DATA

Power Input	5kW
Air Consumption	300 L/Minute
Operating Pressure	6-8 Bars
Bags Per Hour	Up to 1,200
Maximum Reel Band	1,180mm
Minimum Reel Band	600mm
Maximum Reel Diameter	600mm
Maximum Bag Length	1,000mm
Maximum Bag Width	570mm

DESCRIPTION

What sets the model F1200 vertical form, fill and sealing machine apart from other machines is its ability to fill and seal large capacity bags up to 50kg. This is a distinct limitation with other machines.

The F1200 has in fact been designed to cater for the needs of even the most discerning customers while maintaining the simple construction and ease of use that has always distinguished this range of machine.

The F1200 packaging machine has been designed to work with several different types of films and with different batching and weighing systems. This sort of versatility makes it possible to work with many different kinds of products such as: short pasta, dried fruit, legumes, coffee, rice, frozen foods, bread yeast, salt, sugar, pepper, flour, detergent, chemical additives, cements, resins, animal feed, pet food, sand, various granules, fertilisers, earths, seeds, pellets and many others.

FEATURES

- Touch Screen
- Film Reel Hydraulic Lifting
- Film Reel Self-Centring Locking
- Film Reel Automatic Centring
- End-of-Film-Reel Reading Sensors
- Automatic Print Centring
- Quick Film Reel Change Device
- Bag Bottom Vibrator Device
- Different-Size Program Storage
- Sealing Pincers Adjustable Opening
- Sealing Parameter Setting
- Automatic Bag Kicker
- Film Drive Speed Setting

OPTIONS

- Blower Unit and Square Bottom
- Bag Piercing Devices
- Bag Shaking Devices
- Antistatic
- Markers and Coders of Various Types
- Equipped for Dust Extraction

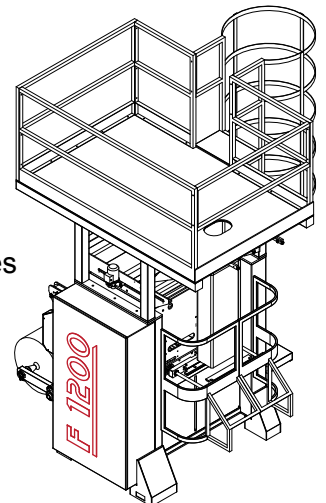

Accuweigh Pty Ltd

by **ESSE GI**

BROCHURE: AW193 | REVISION: F12

WESTERN AUSTRALIA (HEAD OFFICE):
PHONE: (08) 9259 5535

SOUTH AUSTRALIA OFFICE:
PHONE: (08) 8447 5011

NEW SOUTH WALES (SYDNEY) OFFICE:
PHONE: (02) 9728 4877

ACCUWEIGH

www.accuweigh.com.au

VICTORIA OFFICE:
PHONE: (03) 9548 5554

NEW SOUTH WALES (NEWCASTLE) OFFICE:
PHONE: (02) 4966 8900

QUEENSLAND OFFICE:
PHONE: (07) 3265 5520