

"TENNYSON" PAIR OF BOOKCASES

FA8544BO - IVORY

FA8545BO - ESPRESSO

FA8546BO - PLANTATION OAK

FA8547BO - CLASSIC MAHOGANY

FA8543BO - GLAZED PINE

Assembly Instructions



For assistance with assembly contact:

Southern Enterprises Inc.

Customer Service 1-800-633-5096

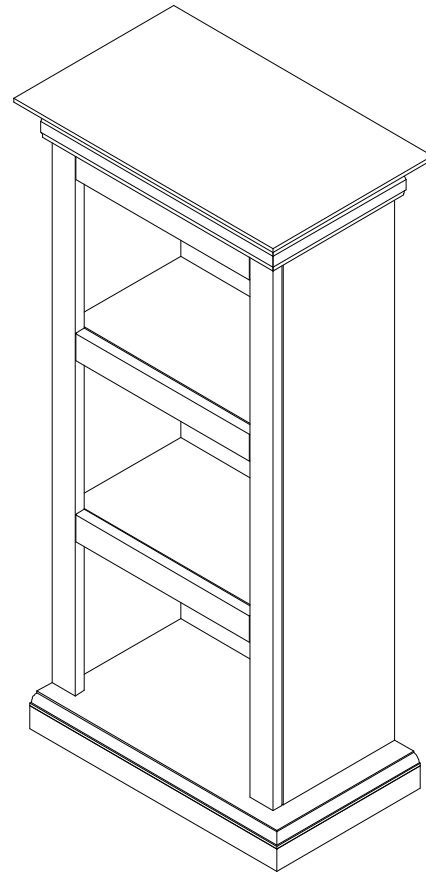
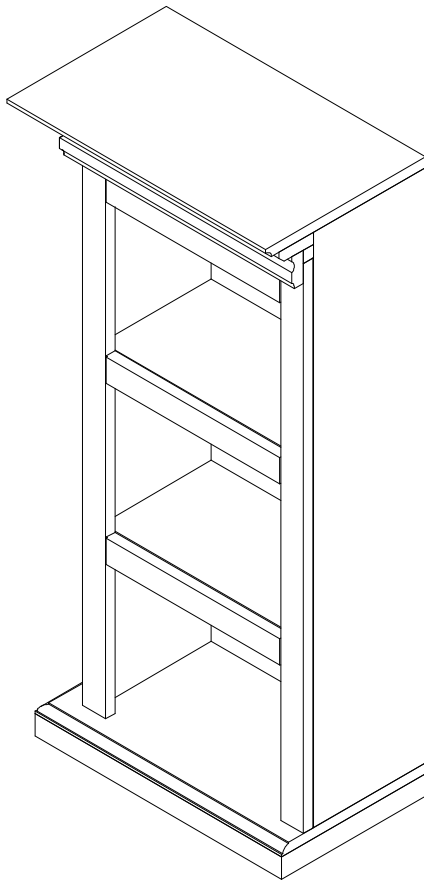

[service@seidal.com](mailto:service@seidal.com)

[www.seidal.com](http://www.seidal.com)

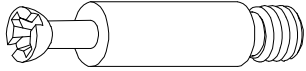

# " TENNYSON "PAIR OF BOOKCASES Parts List

Please review all parts and hardware before disposing of any packaging.  
Call Customer Service if missing hardware. Do not return to store/retailer.  
Using a screw that is too long will cause damage.  
Before beginning assembly, separate each type of screw. Carefully study the  
screw diagrams below . You may receive extra hardware with your unit.

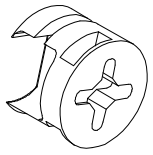
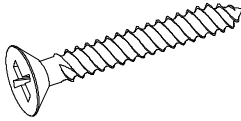
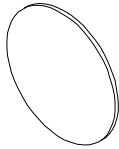
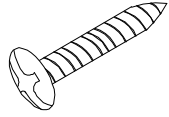
<b>A</b>  Quantity of 24  CAM BOLT	<b>B</b>  Quantity of 32  WOOD DOWEL
<b>C</b>  Quantity of 24  CAM LOCK	<b>D</b>  Quantity of 12  FLAT HEAD LONG SCREW
<b>E</b>  Quantity of 16  COVER	<b>F</b>  Quantity of 36  WOOD SCREW

# "TENNYSON" PAIR OF BOOKCASES

## Parts List

Please review all parts and hardware before disposing of any packaging. Call Customer Service if missing hardware. Do not return to store/retailer. Using a screw that is too long will cause damage. Before beginning assembly, separate each type of screw. Carefully study the screw diagrams below. You may receive extra hardware with your unit.

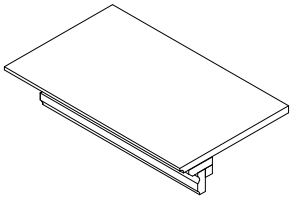
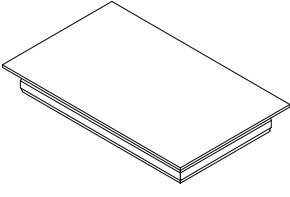
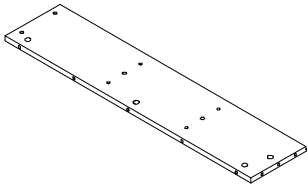
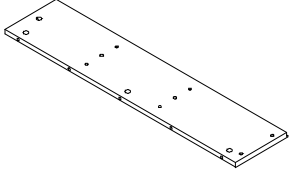
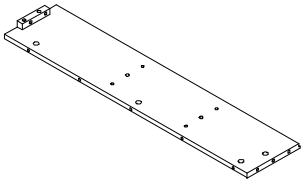
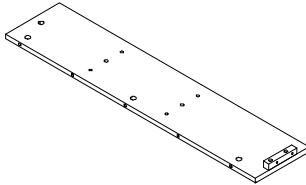
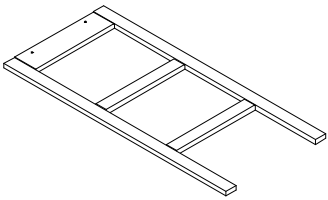
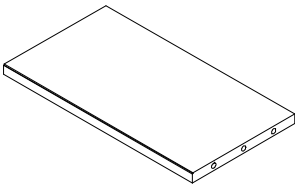
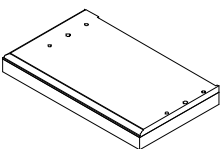
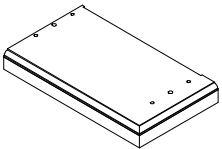
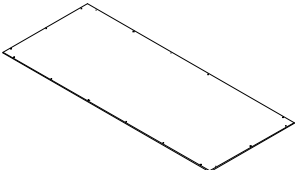
<p>(1)</p>  <p>Quantity of 1</p> <p>LEFT BOOKCASE TOP</p>	<p>(2)</p>  <p>Quantity of 1</p> <p>RIGHT BOOKCASE TOP</p>
<p>(3)</p>  <p>Quantity of 1</p> <p>LEFT SIDE OF LEFT BOOKCASE</p>	<p>(4)</p>  <p>Quantity of 1</p> <p>RIGHT SIDE OF RIGHT BOOKCASE</p>
<p>(5)</p>  <p>Quantity of 1</p> <p>LEFT SIDE OF RIGHT BOOKCASE</p>	<p>(6)</p>  <p>Quantity of 1</p> <p>RIGHT SIDE OF LEFT BOOKCASE</p>
<p>(7)</p>  <p>Quantity of 2</p> <p>FRONT FRAMEI</p>	<p>(8)</p>  <p>Quantity of 4</p> <p>FIXED SHELF</p>
<p>(9)</p>  <p>Quantity of 1</p> <p>LEFT BOOKCASE BASE</p>	<p>(10)</p>  <p>Quantity of 1</p> <p>RIGHT BOOKCASE BASE</p>
<p>(11)</p>  <p>Quantity of 2</p> <p>BACK PANEL</p>	

**Care and Cleaning Instructions:**  
 Before using, wipe with a clean, dry cloth. Periodically apply furniture wax to renew the finish. Avoid rubbing or scratching the surface with rough or abrasive objects.

For replacement parts or questions, please Call Customer Service at 1-800-633-5096 Do not return product to store, please call Manufacturer for assistance, questions or Parts.

**Assembly Tool Required**  
**No.2 Phillips Screw driver (Not Included)**



# " TENNYSON "PAIR OF BOOKCASES Assembly Instructions

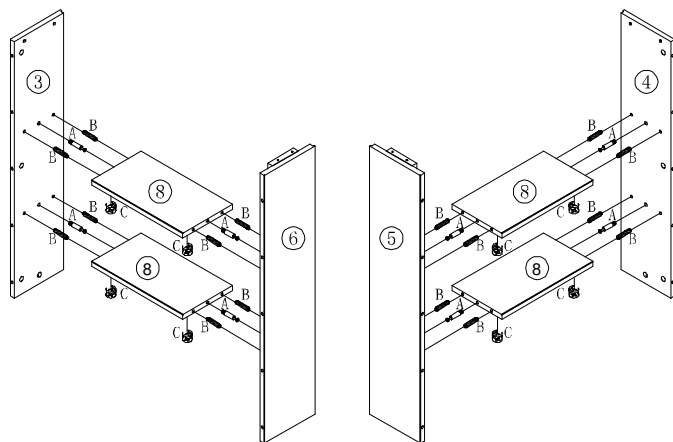

**Figure 1**

USE GLUE (F) TO FILL 1/4 CORRESPONDING HOLES OF LEFT/RIGHT SIDES OF BOOKCASES (3,4,5,6), INSERT 8PCS CAM-BOLTS (A), 16PCS WOOD DOWELS (B) INTO PREDRILLED HOLES ON INSIDES OF LEFT AND RIGHT SIDES OF BOOKCASES (3,4,5,6) AND FIT INTO CORRESPONDING HOLES ON ENDS OF FIXED SHELVES (8). INSERT 8PCS CAM-LOCKS (1) INTO BIG HOLES ON UNDERSIDE OF FIXED SHELVES (8) WITH SLOT FOR SCREWDRIVER FACING OUTWARD. ROTATE CAM-LOCKS (C) CLOCKWISE TO SECURE CAM-BOLTS (A). PUSH COVERS (E) INTO CAM-LOCKS (C). AS FIGURE 1 SHOWN.

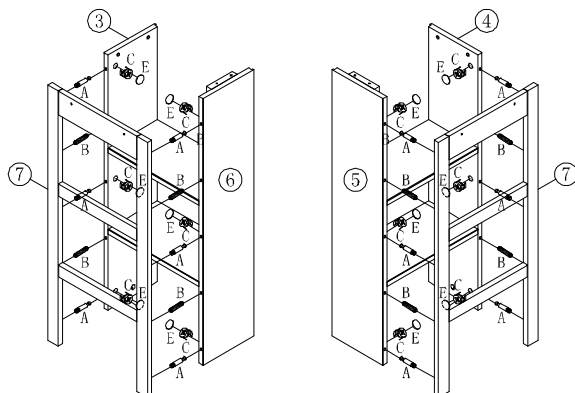

**Figure 2**

INSERT 12PCS CAM-BOLTS (A), 8PCS WOOD DOWELS (B) INTO PREDRILLED HOLES ON BACK OF FRONT FRAMES (7) AND FIT INTO CORRESPONDING HOLES ON FRONT EDGES OF LEFT AND RIGHT SIDES OF BOOKCASES (3,4,5,6). INSERT 12PCS CAM-LOCKS (C) INTO BIG HOLES ON INSIDES OF LEFT AND RIGHT SIDES OF BOOKCASES (3,4,5,6) WITH SLOT FOR SCREWDRIVER FACING OUTWARD. ROTATE CAM-LOCKS (C) CLOCKWISE TO SECURE CAM-BOLTS (A). PUSH COVERS (E) INTO CAM-LOCKS (C). AS FIGURE 2 SHOWN.

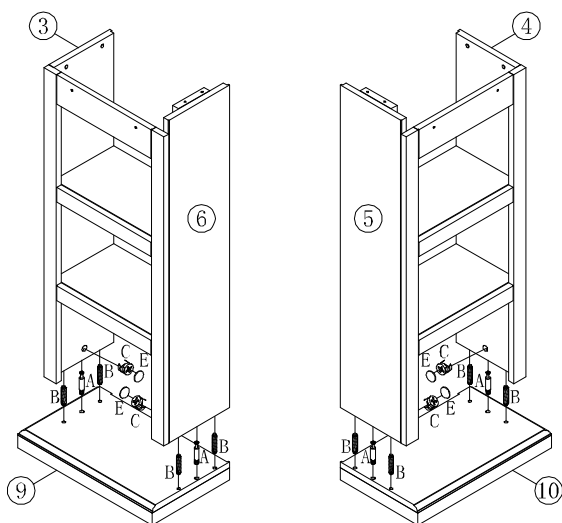

**Figure 3**

INSERT 4PCS CAM-BOLTS (A), 8PCS WOOD DOWELS (B) INTO PREDRILLED HOLES ON UPSIDE OF LEFT AND RIGHT BASES (9&10) AND FIT INTO CORRESPONDING HOLES ON BOTTOM EDGES OF LEFT AND RIGHT SIDES OF BOOKCASES (3,4,5,6). INSERT 4PCS CAM-LOCKS (C) INTO BIG HOLES ON INSIDES OF LEFT AND RIGHT SIDES OF BOOKCASE (3, 4, 5, 6) WITH SLOT FOR SCREWDRIVER FACING OUTWARD. ROTATE CAM-LOCKS (C) CLOCKWISE TO SECURE CAM-BOLTS (A). PUSH COVERS (E) INTO CAM-LOCKS (C). AS FIGURE 3 SHOWN.

# " TENNYSON "PAIR OF BOOKCASES Assembly Instructions

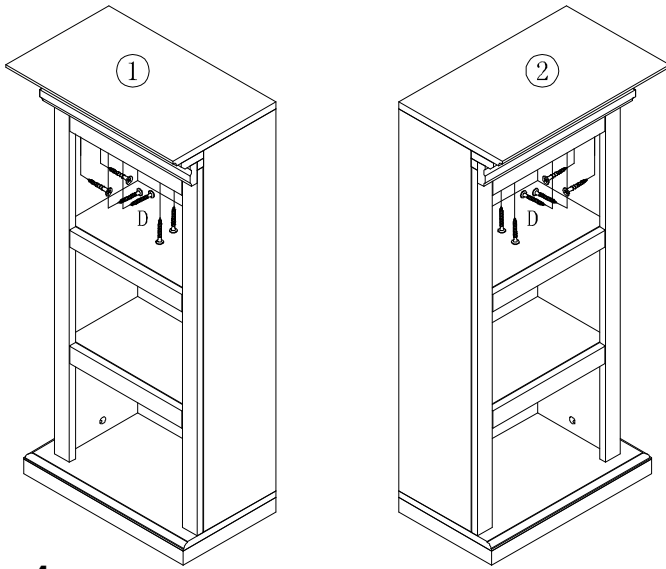

Figure 4

PLACE THE BOOKCASE TOPS (1,2) ONTO TOP EDGES OF LEFT AND RIGHT SIDES OF BOOKCASES (3,4,5,6). INSERT 12PCS FLAT HEAD LONG SCREWS (D) THROUGH PREDRILLED HOLES ON PARTS (3, 4, 5, 6 ) AND TIGHTEN INTO CORRESPONDING HOLES ON UNDERSIDE OF BOOKCASE TOPS (1.2). AS FIGURE 4 SHOWN.

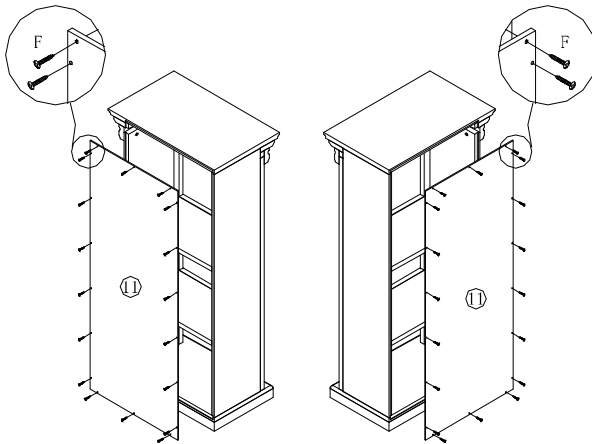

Figure 5

ATTACH THE BACK PANELS (11) ONTO THE UNITS BY USING 36PCS WOOD SCREWS (G) AS FIGURE 5 SHOWN.

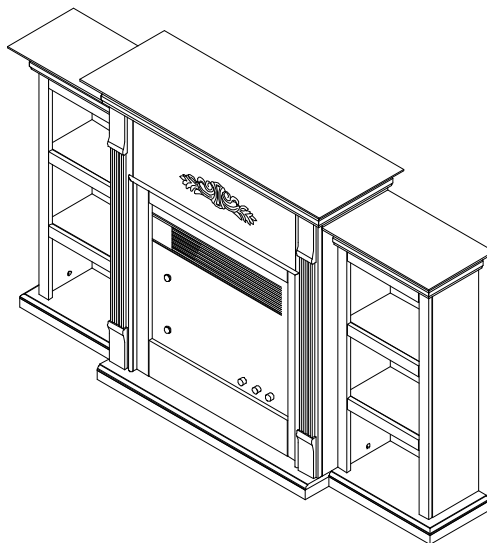

Figure 6

PLACE THE TERRI BOOKCASES BESIDE THE TERRI FIREPLACE.



Customer Service 1-800-633-5096

[service@seidal.com](mailto:service@seidal.com)

Southern Enterprises, Inc.

600 Freeport Parkway, Suite 200

Coppell, Texas, 75019

## FA8543/44/45/46/47B0 - Parts Replacement Form

### Customer Information

Name

Address

City/State/Zip Code

Phone Number

Please indicate where you purchased this item: Store/Website/Catalog

Please indicate color/size/style number:

Style No	Parts Letter	Parts Description	Quantity Needed
<input type="text"/>	<input type="text"/>	<input type="text"/>	<input type="text"/>
<input type="text"/>	<input type="text"/>	<input type="text"/>	<input type="text"/>
<input type="text"/>	<input type="text"/>	<input type="text"/>	<input type="text"/>

Missing or damaged hardware and/or parts will be replaced free of charge. We do not sell parts. Southern Enterprises Inc. will provide replacement parts for only those items purchased within the last 9 months. If this product has not been purchased from our retail affiliates (within 9 months), we are under no obligation to provide parts or replacement merchandise. Parts will not be available for items arriving fully assembled. Parts will be sent if available from SEI

Please contact Southern Enterprises at 800-633-5096 or in Dallas (972) 869-0111/ 9am – 4pm Mon-Fri Central time if you have product issues with your purchase. Please ask for a customer service representative for issues involving damages or replacement parts. Please ask for a technical assistance representative for any issues with product assembly and product construction.

Please contact the retailer that you purchased from for returns.

We'd love to hear from you! Email us photos of our products in your home at [sei@seidal.com](mailto:sei@seidal.com) and we might feature it on our site or use it to model one of our inspirational photos.