

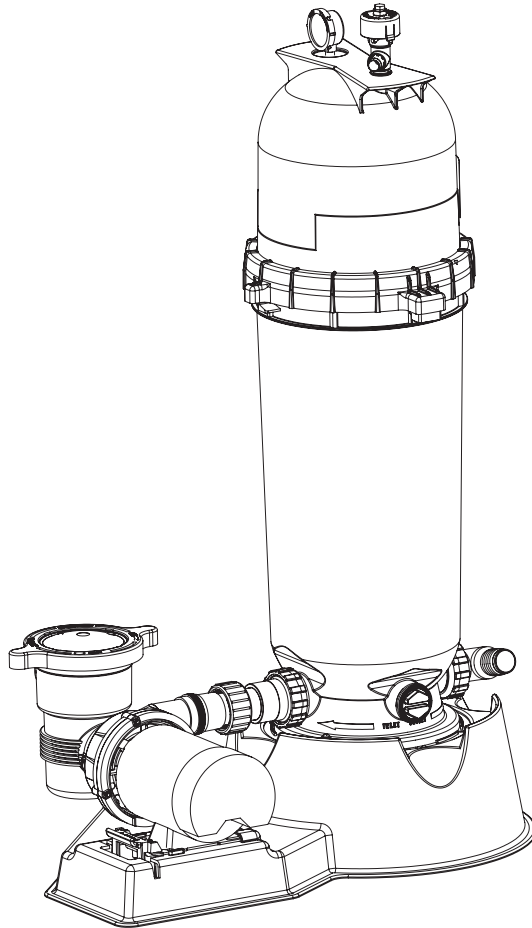

Pump and DE Element Filter System



Installation and User's Guide

IMPORTANT SAFETY INSTRUCTIONS
READ AND FOLLOW ALL INSTRUCTIONS
SAVE THESE INSTRUCTIONS

Technical Support

Sanford, North Carolina (8 A.M. to 5 P.M. ET)

Moorpark, California (8 A.M. to 5 P.M. PT)

Phone: (800) 831-7133

Fax (800) 284-4151

Web sites: visit www.pentairpool.com and staritepool.com

Contents	
Warnings and Important Safety Precautions	i
Section 1: Pump and DE Element Filter Overview	1
Section 2: Installation	2
Section 3: Operation and Maintenance	11
Initial Start-Up	11
Lock Ring Installation.....	12
System Restart	14
Cleaning the Filter	15
Replacing the Filter Element	16
Cleaning the High Flow Manual Air Relief Valve	16
Winterizing the System	18
Technical Data Replacement Parts	18
Section 4: Troubleshooting	19

© 2009 Pentair Water Pool and Spa, Inc. All rights reserved

This document is subject to change without notice

1620 Hawkins Ave., Sanford, NC 27330 • (919) 566-8000

10951 West Los Angeles Ave., Moorpark, CA 93021 • (805) 553-5000

Pentair Water Pool and Spa®, EasyClean™ and High Flow™ are trademarks and/or registered trademarks of Pentair Water Pool and Spa, Inc. and/or its affiliated companies in the United States and/or other countries. Teflon™ is a trademark of E. I. du pont de Nemours and Company Corporation. Baquacil® and Baqua® are registered trademarks of Arch Chemicals, Inc. Unless noted, names and brands of others that may be used in this document are not used to indicate an affiliation or endorsement between the proprietors of these names and brands and Pentair Water Pool and Spa, Inc. Those names and brands may be the trademarks or registered trademarks of those parties or others.

P/N 196043 Rev A - 12/07/09

WARNINGS AND IMPORTANT SAFETY PRECAUTIONS

⚠ DANGER SERIOUS BODILY INJURY OR DEATH CAN RESULT IF THIS PUMP AND DE ELEMENT FILTER ARE NOT INSTALLED AND USED CORRECTLY.

⚠ DANGER INSTALLERS, POOL OPERATORS AND POOL OWNERS MUST READ THESE WARNINGS AND ALL INSTRUCTIONS BEFORE USING THIS PUMP AND DE ELEMENT FILTER.

⚠ WARNING This pump and DE element filter system is intended for use in swimming pool applications.

⚠ WARNING Most states and local codes regulate the construction, installation, and operation of public pools and spas, and the construction of residential pools and spas. It is important to comply with these codes, many of which directly regulate the installation and use of this product. Consult your local building and health codes for more information.



IMPORTANT NOTICE - Attention Installer: This Installation and User's Guide ("Guide") contains important information about the installation, operation and safe use of this pump and DE element filter. This Guide should be given to the owner and/or operator of this equipment.

⚠ WARNING Before installing this product, read and follow all warning notices and instructions in this Guide. Failure to follow warnings and instructions can result in severe injury, death, or property damage. Call (800) 831-7133 for additional free copies of these instructions. Please refer to www.pentair.com for more information related to these products.



⚠ DANGER Water temperature in excess of 100° F (37.7° C) may be hazardous to your health. Prolonged immersion in hot water may induce hyperthermia. Hyperthermia occurs when the internal temperature of the body reaches a level several degrees above normal body temperature of 98.6° F (37° C.). Effects of hyperthermia include: (1) Unawareness of impending danger. (2) Failure to perceive heat. (3) Failure to recognize the need to leave the spa. (4) Physical inability to exit the spa. (5) Fetal damage in pregnant women. (6) Unconsciousness resulting in danger of drowning. The use of alcohol, drugs, or medication can greatly increase the risk of fatal hyperthermia in hot tubs and spas.

⚠ WARNING To reduce the risk of injury, do not permit children to use or operate this pump and DE element filter.

⚠ WARNING When setting up pool water turnovers or flow rates the operator must consider local codes governing turnover as well as disinfectant feed ratios.

⚠ WARNING DO NOT increase pump size; this may increase the flow rate through the system and exceed the maximum flow rate stated on the drain cover.

⚠ WARNING If this pump and DE element filter is intended for use in other than single-family dwellings, a clearly labeled emergency switch shall be provided as part of the installation. The switch shall be readily accessible to the occupants and shall be installed at least 5 feet (1.52 m) away, adjacent to, and within sight of, this pump and DE element filter system.

WARNINGS AND IMPORTANT SAFETY PRECAUTIONS

⚠ DANGER High Pressure from the DE element filter can cause severe injury or major property damage due to tank separation.



Release all pressure and read instructions before working on the DE element filter. If the filter lock ring is adjusted under pressure, the tank can separate, causing serious injury or major property damage.

⚠ WARNING BEFORE WORKING ON FILTER!

- (1) Stop pump.
- (2) Open air release valve.
- (3) Release all pressure from system.

⚠ DANGER RISK OF ELECTRICAL SHOCK OR ELECTROCUTION:



PUMPS REQUIRE HIGH VOLTAGE WHICH CAN SHOCK, BURN, OR CAUSE DEATH. BEFORE WORKING ON PUMP!

Always disconnect power to the pool pump at the circuit breaker from the pump before servicing the pump. Failure to do so could result in death or serious injury to service person, pool users or others due to electric shock.

⚠ WARNING A pool or spa pump must be installed by a qualified pool and spa service professional in accordance with the National Electrical Code and all applicable local codes and ordinances. Improper installation may create an electrical hazard which could result in death or serious injury to pool users, installers, or others due to electrical shock, and may also cause damage to property.

⚠ WARNING Pumps improperly sized or installed or used in applications other than for which the pump was intended can result in serious personal injury or death. These risks may include but not be limited to electric shock, fire, flooding, suction entrapment or serious injury or property damage caused by a structural failure of the pump or other system component.

⚠ WARNING Never exceed the maximum stated pump flow rating.

Only use a pumping system rated for the corresponding flow. FAILURE TO DO SO CAN RESULT IN HAIR OR BODY ENTRAPMENT WHICH CAN CAUSE SERIOUS PERSONAL INJURY OR DEATH. If in doubt about the rating of your system, consult a qualified pool service professional.

⚠ WARNING Pumps are not a substitute for properly installed and secured pool drain covers. An ANSI/ASME A112.19.8 approved anti-entrapment drain cover must be used for each drain. Pools and spas should utilize a minimum of two drains per pump. Regularly inspect all covers for cracks, damage and advanced weathering. If a cover becomes loose, cracked, damaged, broken or is missing, close the pool or spa immediately, shut off the pump, post a notice and keep the pool or spa closed until an appropriate VGB 2008 certified cover is properly installed. Covers deteriorate over time due to exposure to sunlight and pool chemicals. This cover must be replaced within seven (7) years from installation (or earlier if the cover becomes damaged in any way).

WARNINGS AND IMPORTANT SAFETY PRECAUTIONS



SUCTION ENTRAPMENT HAZARD

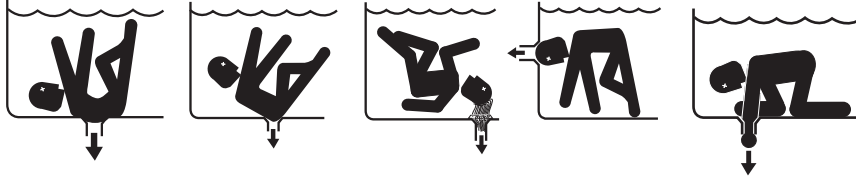

Pool and spa pumps move large volumes of water, which can pose extreme danger if a person's hair comes in close proximity to a drain that is not the proper size for the pump or pumps.

Hair Entanglement – When the hair tangles or knots in the drain cover, trapping the swimmer underwater. This hazard is present when the flow rating of the cover is too small for the pump or pumps.

Limb Entrapment – When a limb is sucked or inserted into an opening resulting in a mechanical bind or swelling. This hazard is present when a drain cover is missing, broken, loose, cracked or not properly secured.

Body Entrapment – When a portion of the body is held against the drain cover trapping the swimmer underwater. This hazard is present when the drain cover is missing, broken or the cover flow rating is not high enough for the pump or pumps.

Evisceration/Disembowelment – When a person sits on an open pool (particularly a child wading pool) or spa outlet and suction is applied directly to the intestines, causing severe intestinal damage. This hazard is present when the drain cover is missing, loose, cracked, or not properly secured.

Mechanical Entrapment – When jewelry, swimsuit, hair decorations, finger, toe or knuckle is caught in an opening of an outlet or drain cover. This hazard is present when the drain cover is missing, broken, loose, cracked, or not properly secured.

WARNINGS AND IMPORTANT SAFETY PRECAUTIONS

The Virginia Graeme Baker Pool and Spa Safety Act imposes certain new requirements on owners and operators of swimming pools and spas. Pools or spas constructed on or after December 20, 2008, shall utilize:

- (A) No submerged suction outlets, a gravity drainage system with ASME/ANSI cover(s), one or more unblockable outlets; or
- (B) A multiple main drain system without isolation capability with suction outlet covers that meet ASME/ANSI A112.19.8 Suction Fittings for Use in Swimming Pools, Wading Pools, Spas, and Hot Tubs and either:
 - (i) A safety vacuum release system (SVRS) meeting ASME/ANSI A112.19.17 Manufactured Safety Vacuum Release Systems (SVRS) for Residential and Commercial Swimming Pool, Spa, Hot Tub, and Wading Pool Suction Systems and/or ASTM F2387 Standard Specification for Manufactured Safety Vacuum Release Systems (SVRS) for Swimming Pools, Spas and Hot Tubs or
 - (ii) A properly designed and tested suction-limiting vent system or
 - (iii) An automatic pump shut-off system.

Pools and spas constructed prior to December 20, 2008, with a single submerged suction outlet shall use a suction outlet cover that meets ASME/ANSI A112.19.8 and either:

- (A) A multiple main drain system without isolation capability, or
- (B) A safety vacuum release system (SVRS) meeting ASME/ANSI A112.19.17 and/or ASTM F2387, or
- (C) A properly designed and tested suction-limiting vent system, or
- (D) An automatic pump shut-off system, or
- (E) Disabled submerged outlets, or
- (F) Suction outlets shall be reconfigured into return inlets.

For information about the Virginia Graeme Baker Pool and Spa Safety Act, contact the Consumer Product Safety Commission at (301) 504-7908 or visit www.cpsc.gov.

NOTE: Always turn off all power to the pool pump before installing the cover or working on any suction outlet.

Two Speed Pump Controls Notice (Title 20 Compliance)

Please read the following important Safety Instructions. When using two-speed pumps manufactured on or after January 1, 2008, the pump's default circulation speed **MUST** be set to the **LOWEST SPEED**, with a high speed override capability being for a temporary period not to exceed one normal cycle, or two hours, whichever is less.

Section 1

Pump and DE Element Filter Overview

This system operates under pressure and if assembled improperly or operated with air in the water circulation system it can separate and result in an accident causing serious bodily injury. A warning label has been affixed to the filter and should not be removed. Keep safety labels in good condition and replace if missing or illegible. (For free labels call, (919)-774-4151). Pumps and filters should never be tested or subjected to air or gas under pressure. All gases are compressible and under pressure create a danger. Serious bodily injury or property damage could occur if the pump or filter is subjected to air or gas pressure.

The system consists primarily of a centrifugal pump, a DE element filter, a connecting hose and a mounting base. Your centrifugal pump is driven by an electric motor. The motor is directly attached to the pump impeller. As the electric motor turns it causes the water to flow. The water flows into the hair and lint pot inlet and through the basket assembly to pre-strain large particles. The flow then enters the center of the pump housing. The flow goes through the impeller into the stationary diffuser, out the pump discharge port, through the connecting hose and into the filter inlet port at the bottom of the filter. The water is distributed evenly across the DE filter element. The dirt is removed by the element and the clean water flows through the outlet port at the bottom of the tank. The clean water then returns to the pool through the piping or hoses.

After a period of time, dirt will accumulate in the filter element causing a resistance to the flow of water through the filter. This resistance results in a diminished flow of water and a rise in the pressure of the filter. Eventually the filter element will have removed so much dirt and the filter pressure risen to such a point that it will be necessary to clean your filter.

The function of the filter is to remove suspended matter from the water. It does not sanitize the water. For sparkling clear water, the water must be sanitized as well as chemically balanced. Pool chemistry is a specialized area, please consult your local pool specialist for specific details. In general, proper pool sanitation requires a free chlorine level of 2 to 4 ppm and a pH range of 7.2 to 7.8. Your filtration system should be designed to meet your local health codes. As a minimum, you must be sure that your system will turn over the total volume of water in your pool at least twice in a 24 hour period.

⚠ WARNING

This filter operates under high pressure. When any part of the circulating system (e.g., clamp, pump, filter, valves, etc.) is serviced, air can enter the system and become pressurized. Pressurized air can cause the lid or lock ring to separate which may result in serious injury, death, or property damage. To avoid this potential hazard, follow these instructions.

1. Before the assembly, disassembly, or adjustment of the lid or lock ring or any other service of the circulating system:
 - (a) Turn the pump off and shut off any automatic controls to ensure the system is not inadvertently started during the servicing;
 - (b) Open manual air relief valve;
 - (c) Wait until all pressure is relieved, pressure gauge must read zero (0).
2. Whenever installing the filter lock ring, follow the filter lid and lock ring installation instructions exactly.
3. Once service on the circulating system is complete, follow system restart instructions exactly.
4. Maintain circulation system properly. Replace worn or damaged parts immediately (e.g., lock ring, pressure gauge, relief valve, o-rings, etc.).
5. Be sure that the filter is properly mounted and positioned according to instructions provided.

⚠ WARNING

Failure to operate your filter system or inadequate filtration can cause poor water clarity obstructing visibility in your pool and can allow diving into or on top of obscured objects, which can cause serious personal injury or drowning.

Section 2

Installation

1. **Read and understand all instructions before attempting to install, operate or maintain your pump and DE filter system.**
2. Provide space and lighting for routine maintenance access. Locate the system close to the pool. Install electrical controls (e.g., on/off switches, timers, control systems, etc.) at least five (5) feet from the filter. This will allow you enough room to stand clear of the filter during system start up. Systems that are unassembled should be assembled at this point. See special instructions A through P.
 - A. Make sure all electrical breakers and switches to the pump are switched off, and disconnect the communication cable from the pump before installing the base.
 - B. Remove all individual components from carton and inspect for any visible damage. If carton or parts are damaged contact seller or freight company.
 - C. Place the system support base on the ground close to the final location of the unit. See Figure 1.

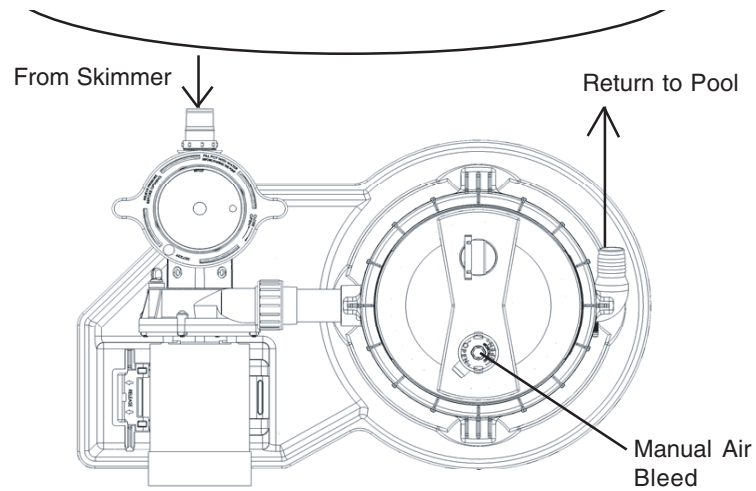

Figure 1.

- D. Place the filter tank foot on the filter end of the system base.
- E. Position the filter tank foot so that the filter tank inlet faces the pump end of the system base. See Figure 2.

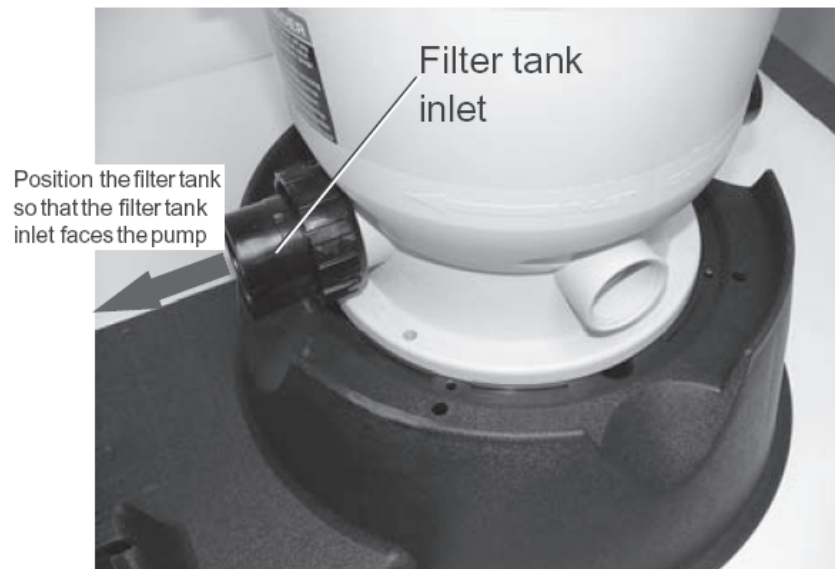

Figure 2.

4

- F. The system base provides screw holes that align with the screw holes in the foot of the filter tank. See Figure 3.

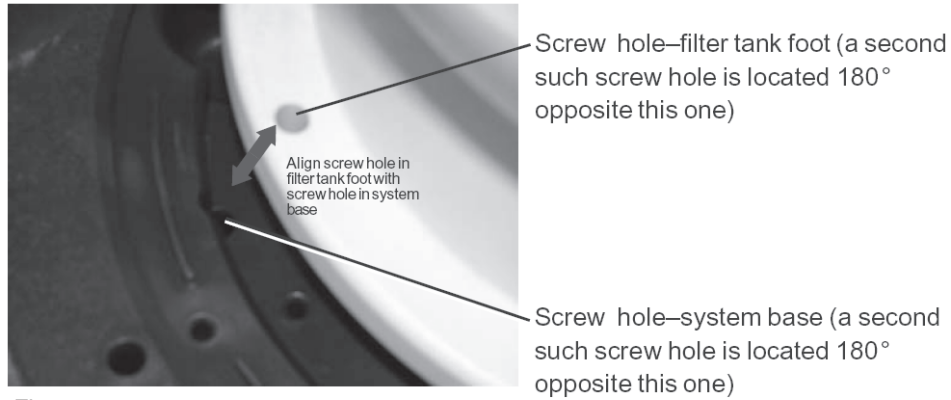

Figure 3.

- G. Remove the filter from the base.
- H. Hand seat the 1/4-20 brass inserts (larger inserts) into the identified holes in the systems base. See Figure 4.
- I. Using a flat-head screw driver, drive the 1/4-20 brass inserts into the holes in the system base. Note: The blade of the screw driver must be wide enough to catch both slots in the end of the insert. See Figure 5.

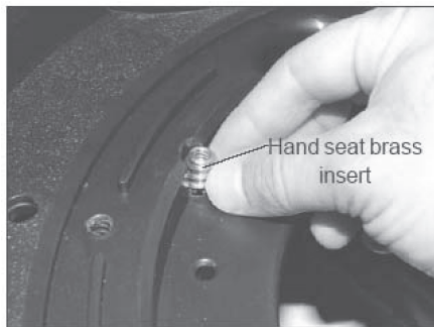

Figure 4.



Figure 5.

- J. Place the filter tank back onto the filter end of the systems base and align the two screw holes in the tank foot with the two holes in the system base that now contain the brass inserts.
- K. Install a ¼-20 x 1-1/2” long screw and ¼” flat washer through one of the screw holes in the tank foot. Tighten the screw into the brass insert in the systems base. Repeat with the other hole located 180° opposite the first one. See Figure 6.



Figure 6.

- L. Install the pump to filter connection hose to the inlet port of the filter. Tightening the union nut that is attached to the filter only hand tight.
- M. The pump may now be attached to the pump support side of the base. The pump should be oriented as indicated in Figure 1.

6

- N. Slide the pump foot between the claw fasteners and the release latch. See Figure 7. Seat the pump by pushing down on it until the release latch clicks into place on the pump foot. See Figure 8.
- O. Connect the pump to filter connection to the discharge port of the pump. Tighten the union nut hand tight.
- P. Install the two (2) push-in fasteners through the slots in the foot of the motor, into the two (2) holes in the system base near the release latch.

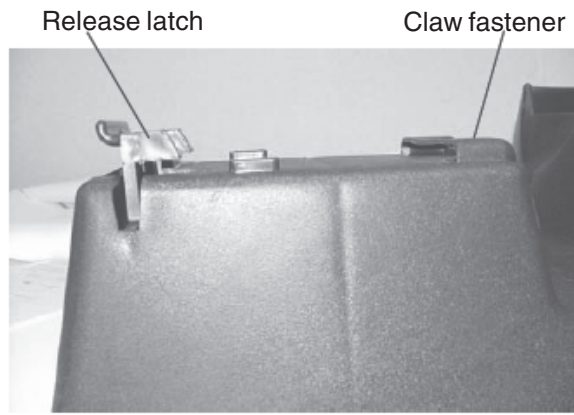

Figure 7.

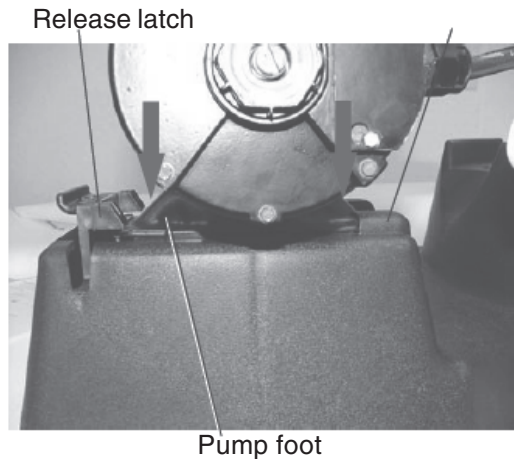

Figure 8.

3. Insert the check valve into the outlet port of the filter, making sure that the rubber diaphragm is facing outward. See Figure 9.

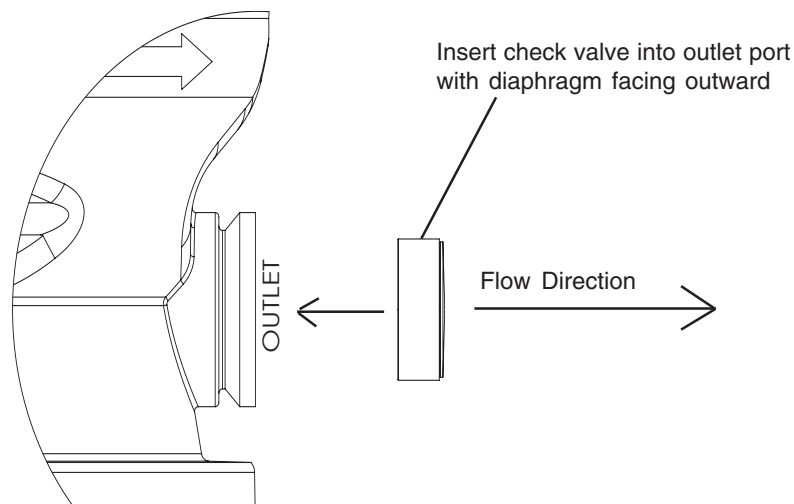

Figure 9.

4. Install the union elbow adaptor to the outlet port of the tank. Tighten the union nut that is attached to the filter only hand tight. Secure the flex hose with a hose clamp. Tighten the clamp with a screwdriver.
5. Screw the hose adaptor, item number 711006, into the inlet port of the pump. This is the opening in the sidewall of the pump pot. Use Teflon™ tape on the threads and tighten no more than one (1) turn past hand tight. Connect the flex hose to this adaptor with a hose clamp and tighten with a screwdriver.
6. Install the High Flow™ manual air relief valve to the lid of the filter. The High Flow manual air relief uses the O-ring only, there is no need for thread sealing compound. Position the system to safely direct water drainage. Rotate the High Flow™ manual air relief valve to safely direct purged air or water. Water discharged from an improperly position filter or valve can create an electrical hazard as well as damage property.
7. Install the pressure gauge in the ¼" NPT threaded hole in the tank lid, using Teflon® tape on the threads.
8. Now, move the system to its final position. The system must be placed on level solid earth. The entire system filled with water can weigh over one hundred pounds. Position the system so that the instructions, warnings and pressure gauge are visible to the operator. Also, position the system so that the piping connections and drain port are convenient and accessible for servicing and winterizing.
9. Provide sufficient clearance around the filter to permit visual verification that the lock ring is properly installed. See Figure 10.

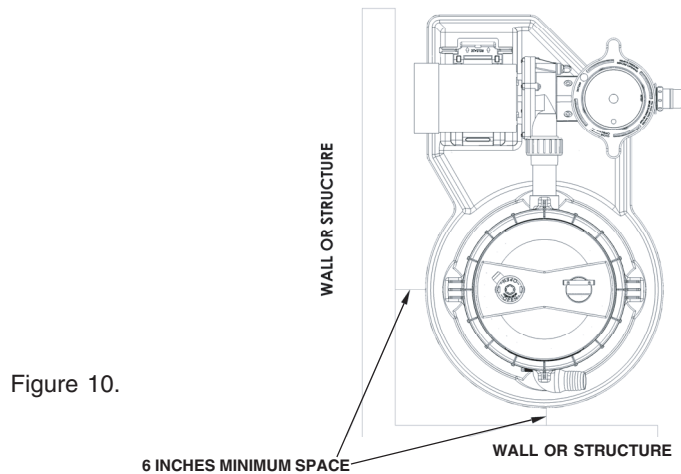

Figure 10.

10. Provide sufficient space above the filter to remove the filter lid or for cleaning and servicing. This distance will vary with the model of filter you are using. See Table 1 below for required vertical distance.

Table 1.

Model	Size	Required vertical clearance
ECDE60	15 sq. ft.	43 in
ECDE90	30 sq. ft.	75 in

11. Connect the flex hose from the outlet side of the filter to the return fitting on the pool wall, using a hose clamp. Connect the flex hose from the inlet side of the pump pot to the skimmer, using a hose clamp.

⚠ DANGER

Risk of electrical shock or electrocution. Position the filter and High Flow manual air relief valve to safely direct water drainage and purged air or water. Water discharged from an improperly positioned filter or valve can create an electrical hazard that can cause severe personal injury as well as damage property.



12. Make all plumbing connections in accordance with local plumbing and building codes. Filter plumbing connections are provided with an O-ring seal. Use only a silicone based lubricant on the O-rings. Do not use pipe joint compound, glue or solvent on the bulkhead connections
13. The maximum working pressure of this filter is 50 psi. Never subject this filter to pressure in excess of this amount, even when conducting hydrostatic pressure tests. Pressure above 50 psi can cause the lid to separate, which can result in severe injury, death, or property damage.

When performing hydrostatic pressure tests or when testing for external leaks of the completed filter and plumbing system, insure that the Maximum Pressure that the filtration system will be subjected to DOES NOT EXCEED THE MAXIMUM WORKING PRESSURE OF ANY OF THE COMPONENTS CONTAINED WITHIN THE SYSTEM. In most cases, the maximum pressure will be stated on each component of the system.



High Pressure:
Improper tank lid and lock ring assembly could cause the lid to separate and cause serious injury and/or major property damage.

If doubt exists as to the pressure to which the system will be subjected, install an ASME approved automatic Pressure Relief or Pressure Regulator in the circulation system for the lowest working pressure of any of the components in the system.

14. Use sealant on all tapered male connections of pipes and fittings. Use only sealant compounds suited for plastic pipe. Support pipe to prevent strains on filter, pump or valve. **DO NOT USE PETROLEUM BASED PRODUCTS**
15. Never store pool chemicals within ten (10) feet of your pool filter or pump. Pool chemicals should always be stored in a cool, dry, well ventilated area.

WARNING Chemical fumes and/or spills can cause serious corrosion to the filter and pump structural components. Structurally weakened components can cause filter, pump or valve attachments to separate and could cause serious bodily injury or property damage.

WARNING The system's centrifugal pump operates with electrical voltage, and can generate both vacuum and pressure in the water system. When properly wired and plumbed, this pump will operate in a safe manner.

WARNING High voltage can cause serious or fatal injury. Always install a suitable GFCI at the power source of this unit as an added safety precaution. Article 681-31 of the NEC requires that a GFCI be used if this pump is used with a storable pool.

16. Avoid over tightening the pipe threads when connecting fittings to pump or filter. Proper procedure is to apply a pipe sealant to the thread and then install hand tight plus one (1) turn. **DO NOT OVER TIGHTEN.**

17. The pump suction line should not be smaller than the pipe on the inlet of the pump.
18. **Electrical connection of the pump should be performed by a qualified pool and spa service professional in accordance with the National Electrical Code or your local electrical code.**

Recommended Circuit Breaker and Wiring Data					
Motor HP	Branch Circuit	Volts/Hz/Phase	Distance in Feet of Branch Circuit		
			0-50 Ft.	50-100 Ft.	
3/4	15 AMP	115/60/1	No. 14	No. 14	Min. Service
1	15 AMP	115/60/1	No. 12	No. 12	Wire
1-1/2	20 AMP	115/60/1	No. 12	No. 10	Size
1-1/2	15 AMP	230/60/1	No. 14	No. 14	To Motor

⚠ WARNING	Blockage of suction fittings can cause serious or fatal injury due to drowning. To reduce the risk of injury, do not permit children to operate this product.
⚠ WARNING	Never work on the pump while it is running or power is still connected. High voltage can cause serious or fatal injury. A suitable ground fault interrupter should always be installed at the power supply source of this unit. Be sure to ground the motor before connecting to electrical AC power supply. Failure to ground the motor can cause serious or fatal electrical shock hazard. DO NOT ground to a gas supply pipe line.

19. Use lug on top of motor frame to bond together motor and all metallic parts of pool, spa, or hot tub structure and all electrical equipment, metal conduit, and metal piping with a solid copper conductor not less than No. 8 A.W.G.
20. The pump motor must be wired for the proper voltage in accordance with the diagram supplied with the motor. Note: Wiring the motor with the incorrect supply voltage will cause damage to the motor and void warranty.
21. The product may be furnished with a 6 ft. three (3) prong test cord. The cord is provided for your convenience to allow you to check the pump operation before installing the system on the pool. The test cord should NOT be used for permanent connection. When checking the pump operation, do not run the pump longer than 30 seconds. Damage to the pump's mechanical seal could result if ran longer than 30 seconds.

⚠ WARNING**⚠ DANGER****FOR CORD AND PLUG-CONNECTED UNITS****RISK OF ELECTRICAL SHOCK:**

Connect only to a ground type receptacle protected by a Ground Fault Circuit Interrupter (GFCI). Contact a qualified electrician if you cannot verify that the receptacle is protected by GFCI.

Do Not Bury Cord. Locate cord to minimize abuse from lawn mowers, hedge trimmers, and other equipment.
To reduce the risk of electrical shock, replace damaged cord immediately.
To reduce the risk of electrical shock, Do Not Use an extension cord to connect unit to electrical supply; provide a properly located outlet.

Section 3**Operation and Maintenance****Initial Start-Up**

1. Be sure all connections have been made and are secure.
2. Make sure the hair and lint pot of the pump is filled with water. **FAILURE TO FILL THE HAIR AND LINT POT WITH WATER WILL RESULT IN DAMAGE TO THE PUMP AND PUMP SEAL.**
3. **OPEN THE HIGH FLOW MANUAL AIR RELIEF VALVE UNTIL IT SNAPS INTO THE FULL OPEN POSITION. THIS ONLY REQUIRES A ¼ TURN COUNTERCLOCKWISE.**
4. **STAND CLEAR OF THE FILTER.** Start the pump allowing the filter tank to fill with water. Close the High Flow manual air relief valve after a steady stream of water appears.
5. Remove the skimmer lid, put the recommended amount of diatomaceous earth (D.E) into the skimmer. The D.E. will be drawn into the filter and deposited evenly upon the element cartridge. Now the filter is providing the pool with bright, clean water. **NOTE: DO NOT OPERATE FILTER WITHOUT D.E. CHARGE FOR MORE THAN TWO MINUTES. DO NOT USE MORE THAN THE RECOMMENDED AMOUNT OF D.E. IN YOUR FILTER.**

REGENERATIVE D.E. RECOMMENDATION

The amount of D.E. should be between 1 and 2 pounds for each 10 square feet of filter area or:

MODEL	Pounds of D.E.
ECDE60	1.5
ECDE90	3.0

Note: 1/2 lb of D.E. will fill a 13oz. coffee can.

6. Your filter has now started its filter cycle. You should check that the water is returning to the pool and take note of the operating pressure.
 7. Check the system for water leaks. If a leak is found, shut off pump before correcting leak.
 8. The pressure gauge is the primary indicator of how the filter is operating. Maintain your pressure gauge in good working order.
 9. Clean your filter when pressure reads between 8-10 psi higher than the original starting pressure. Your filter pressure reading will increase as it removes dirt from your pool. However, this buildup of pressure will vary due to different bathing loads, temperature, weather conditions, etc.
- A. My original starting pressure is _____ psi with the clean filter.

I SHOULD CLEAN THE DE FILTER ELEMENT AT _____ PSI.

⚠ DANGER	 <p>This filter operates under pressure. With the lock ring and lid installed properly and operated without air in the system, this filter will operate in a safe manner. Air entering the filter and the lock ring or lid not installed correctly can cause the lid to separate, which could cause serious personal injury and/or property damage.</p>
-----------------	--

⚠ WARNING	<p>DO NOT attempt to disassemble or adjust the filter unless you fully understand it's operation. Serious injury or death can occur if the equipment is improperly handled. Consult a pool service professional for maintenance and service assistance.</p>
------------------	---

LOCK RING INSTALLATION

These instructions **MUST BE FOLLOWED EXACTLY** to prevent the lid from separating during system restart or later operation .

1. Perform the following steps before working on any part of the circulating system (e.g., lock ring, pump, filter, valves, etc.).
 - a.) Turn the pump off and shut off any automatic controls to ensure that the system is not inadvertently started during servicing.
 - b.) Open the air relief valve.
 - c.) Wait until pressure is relieved. Never attempt to assemble, disassemble, or adjust the lock ring while there is any pressure in the filter.
2. Be certain the O-ring is in position in the lower tank half. Place the filter lid over the lower tank half. Make sure it is fully and firmly seated on the tank half. See Figure 11 on the following page.

⚠ DANGER This filter operates under pressure. With the lock ring and lid installed properly and operated without air in the system, this filter will operate in a safe manner. Air entering the filter and the lock ring or lid not installed correctly can cause the lid to separate, which could cause serious personal injury and/or property damage.



⚠ DANGER THIS FILTER OPERATES UNDER HIGH PRESSURE. WHEN ANY PART OF THE CIRCULATING SYSTEM (e.g., LOCK RING, PUMP, FILTER, VALVES, ETC.) IS SERVICED, AIR CAN ENTER THE SYSTEM AND BECOME PRESSURIZED. PRESSURIZED AIR CAN CAUSE THE LID TO SEPARATE WHICH CAN RESULT IN SEVERE INJURY, DEATH, OR PROPERTY DAMAGE. TO AVOID THIS POTENTIAL HAZARD, FOLLOW THESE INSTRUCTIONS.



3. Place locking ring over tank lid, and centering the lock ring on the threads of the tank body, turn the lock ring clockwise until the safety latches click and the lock ring hits the stops on the body. **DO NOT ATTEMPT TO OVER-TIGHTEN THE LOCK RING AFTER LOCK RING HAS HIT THE STOPS ON THE BODY.**
4. **Proceed to “System Restart.”**

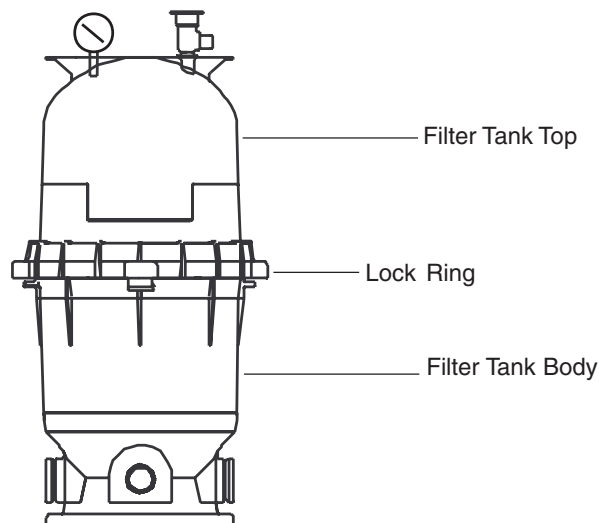



Figure 11.

SYSTEM RESTART

	<p>⚠ DANGER THIS FILTER OPERATES UNDER HIGH PRESSURE. WHEN ANY PART OF THE CIRCULATING SYSTEM (e.g., LOCK RING, PUMP, FILTER, VALVES, ETC.) IS SERVICED, AIR CAN ENTER THE SYSTEM AND BECOME PRESSURIZED. PRESSURIZED AIR CAN CAUSE THE LID TO SEPARATE WHICH CAN RESULT IN SEVERE INJURY, DEATH, OR PROPERTY DAMAGE. TO AVOID THIS POTENTIAL HAZARD, FOLLOW THESE INSTRUCTIONS.</p>
---	---

1. **Open the High Flow manual air relief valve until it snaps into the full open position (this only requires a quarter turn counterclockwise).** Opening this valve rapidly releases air trapped in the filter.
2. Stand clear of the filter tank, then start the pump.
3. Close the High Flow manual air relief valve after a steady stream of water appears.
4. The system is not working properly if either of the following conditions occur.
 - a. A solid stream of water does not appear within 30 seconds after the pump's inlet basket fills with water.
 - b. The pressure gauge indicates pressure before water outflow appears.

If either condition exists, **shut off the pump immediately**, open valves in the water return line to relieve pressure, and clean the air relief valve, see “Cleaning the High Flow Manual Air Relief Valve” on page 16. If the problem persists, call Technical Support (1-800-831-7133) for assistance.

	<p>WARNING The following information should be read carefully since it outlines the proper manner of care and operation for your filter system. As a result of following these instructions and taking the necessary preventative care, you can expect maximum efficiency and life from your filtration system.</p>
---	--

	<p>CAUTION Please pay attention to all manufacturers' posted instructions, warnings and cautions when using Baquacil® Filter Cleaner.</p>
---	--

CLEANING THE FILTER

1. Turn the pump off, shut off any automatic controls to ensure that the system is not inadvertently started during servicing.
2. Open the filter High Flow manual air relief valve, (and the waste drain valve, or cap, if your system has one).

NOTE: Special care must be taken when cleaning the filter element used in a swimming pool or spa using Baquacil® Filter Cleaner as a sanitizer. Because of the way Baquacil works, the filter media must be cleaned more thoroughly and more frequently than in a chlorine system. If extreme care is not taken to completely remove all residue from the filter element a buildup will occur. This buildup will significantly shorten the life of the filter element. Baquacil is a mild coagulant which combines bacterial cells as well as other small particles contributed by the environment, bathers, etc. into particles large enough to be trapped by the filter. In comparison with all other trapped contaminants in a typical pool or spa the amount of bacterial cells that are deposited on the filter is minimal. The resulting deposit is a gray sticky film which can only be removed with Baqua® Spa cleaner. If TSP (Trisodium Phosphate) or any TSP type cleaner is used prior to stripping the film, the cleaner and the gray film will combine to form a gum-like substance. Once this occurs, the substance cannot be removed from the media and the filter media must be replaced.

3. Remove hair and lint strainer pot lid and clean basket. Replace basket and secure lid.
4. Disconnect air relief drain hose if installed.
5. Remove locking ring by depressing safety latches on both sides of ring and rotate counterclockwise, then remove tank lid.
6. Remove the DE Cartridge style element assembly by placing hands in lifting handles and pulling straight up on the element assembly.
7. Using a garden hose with a nozzle, direct water spray at the element to dislodge and wash away accumulated foreign matter.
8. Clean and remove debris from inside the filter tank and from O-ring and O-ring groove on tank body.
9. Replace the clean element assembly into the filter tank body, making sure it is fully seated. Align the arrow on the handle frame with inlet port of filter.

10. Replace the tank lid onto the tank body making sure it is fully and firmly seated on the tank body.
11. Place lock ring over tank lid, and centering the lock ring on the threads of the tank body, turn the lock ring clockwise until the safety latches click and the lock ring hits the stops on the body. **DO NOT ATTEMPT TO OVER-TIGHTENED THE LOCK RING AFTER LOCK RING HAS HIT THE STOPS ON THE BODY.**

A yellow rectangular box with a black border containing a black triangle with an exclamation mark and the word "CAUTION" in bold black capital letters.

Any time the filter tank is opened, and/or element assembly is removed, be sure to generously coat the O-ring with silicone lubricant before reassembling the unit. **DO NOT USE PETROLEUM BASED LUBRICANTS BECAUSE THEY HAVE A DETERIORATING EFFECT ON RUBBER.**

12. Replace drain cap and reinstall air relief valve drain hose if used.

REPLACING FILTER ELEMENT

Element life will vary with pool conditions such as bather load, wind, dust, etc. You can expect an average media life of three years under normal conditions.

1. To replace the element, follow “Cleaning The Filter” instructions on page 15.

CLEANING THE HIGH FLOW MANUAL AIR RELIEF VALVE

1. Turn the pump off and shut off any automatic controls to ensure that the system is not inadvertently started during servicing.
2. **OPEN THE HIGH FLOW MANUAL AIR RELIEF VALVE UNTIL IT SNAPS INTO THE FULL OPEN POSITION, THEN WAIT UNTIL ALL PRESSURE IS RELIEVED.**
3. With the relief valve attached to the filter tank, pull out the locking tabs and remove the valve stem and cover assembly with a counterclockwise and lifting motion, see Figure 12.

4. Clean debris from the valve stem and body. Verify that the filter tank's air passage is open by inserting a 5/16" drill bit through the valve body. Verify that the O-rings are in good condition, properly positioned, and lubricated with a silicone base lubricant.
5. Reinstall the valve stem and cover assembly with a downward and clockwise motion until it snaps into position.

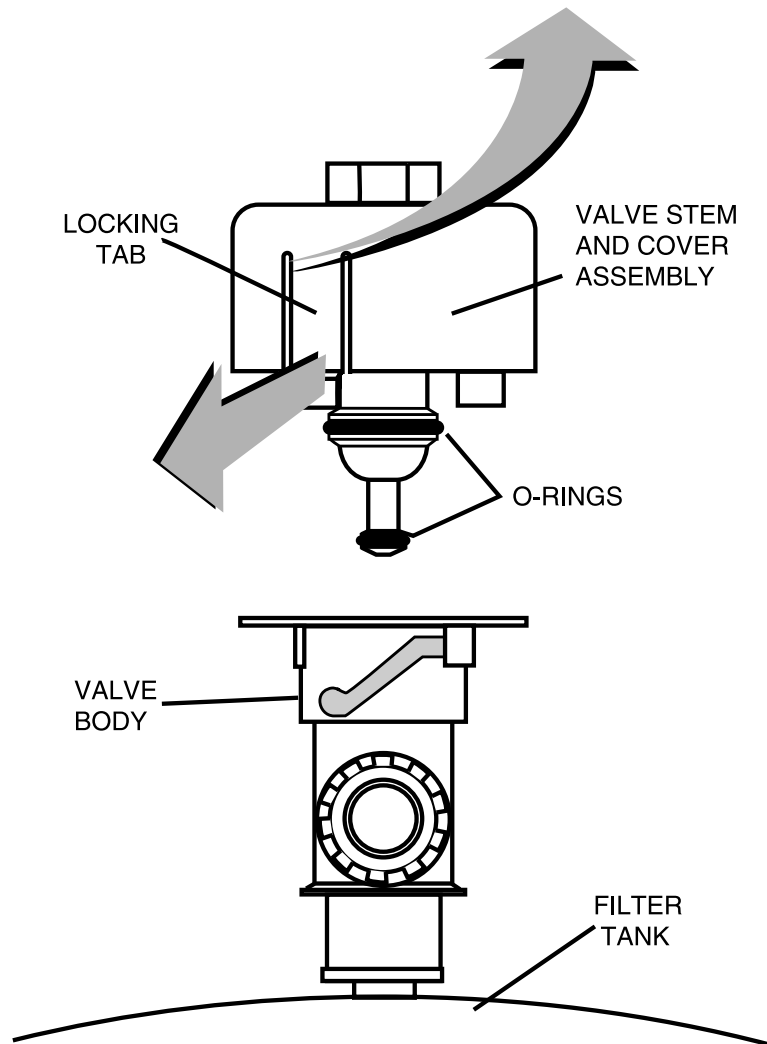

Figure 12.

Winterizing the System

⚠ CAUTION Allowing water to freeze in the system will damage the system and cause potential water damage/flooding and potential property damage.

1. In areas that have freezing winter temperatures, the pool equipment must be winterized to protect it from damage.
2. Open the High Flow manual air relief valve.
3. Remove the drain port cap at the bottom of the filter.

IMPORTANT NOTE: Remove drain port cap for draining water from filter. Leave the drain port cap off and store it during the time the system is shut down.

4. Drain all appropriate system piping.
5. It is recommended that the pump and filter be covered with a tarpaulin or plastic sheet to inhibit deterioration from the weather. DO NOT wrap the pump motor with plastic.
6. In installations where the pump cannot be drained, a 40% Propylene Glycol 60% water solution will protect to -50° F (-45.5° C)

Note: Do not use anti-freeze solutions except Propylene Glycol; as other anti-freeze are highly toxic and will damage the pump.

Technical Data and Replacement Parts

Note

Please see the provided insert sheet for Technical Data and Replacement Parts information specific to your system.

Section 4

Troubleshooting

- A. Air entering your filter is dangerous and can cause the lid to separate. Correct any conditions in your filtration system that allows air to enter the system.
1. Some common ways to identify air entering the system:
 - a. Low water level in pool or spa - skimmer is starving for water with pump running. Add water to pool or spa.
 - b. Air bubbles or low water level in pump hair and lint pot are caused by; low water level, clogged skimmer basket, split suction cleaner hose, leak in pump hair and lint pot lid, or leak in pump suction line.
 - c. Air bubbles coming out of water return lines into pool or spa with pump running, see items 1.a and 1.b of this section.
 - d. Air is discharged from the air relief valve on top of the filter when the valve is opened with the pump running, see items 1.a and 1.b of this section, above.
- B. Until the water initially put into the pool has been completely filtered, short filter cycles in between cleanings are normal. In most cases pool owners are dismayed by the undesirable color and appearance of water in a newly filled pool. Plaster dust can be responsible for short filter cycles, requiring frequent cleaning.
- C. If pressure drops on gauge, check skimmer basket and pump basket first for debris. If the baskets are clean, shut off power to pump and turn off any automatic controls. Then turn motor shaft with your fingers. If it turns freely, then the pump must be disassembled and the impeller checked to see if it is clogged. If it is not frozen or clogged, then there is an obstruction in the line between the pool and the pump.
- D. The pressure gauge is an important part of the filter system. It is your primary indicator of how the system is operating. Maintain your pressure gauge in good working order. Check the operation of your pressure gauge in the following manner:
1. The pressure gauge should go to zero (0) when the system is turned off and pressure is relieved.
 2. The pressure gauge should indicate pressure when the system is operating.
 3. The pressure gauge should be readable and not damaged in any way.
 4. Replace the pressure gauge if it is not meeting the requirements of items D.1 through D.3 of this section, above.

Problem	Cause	Action
Pool water not sufficiently clean.	<ol style="list-style-type: none"> 1. Pool chemistry not adequate to inhibit algae growth. 2. Too frequent an element cleaning cycle. 3. Inadequate turnover rate. 	<p>Maintain pool chemistry or consult service technician.</p> <p>Allow pressure to build to 10psi above clean filter condition before cleaning element.</p> <p>Run system for longer time or consult dealer or pool service technician.</p>
Higher filter pressure.	<ol style="list-style-type: none"> 1. Insufficient element cleaning 2. Partially closed valve or restriction. 	<p>Clean until all debris is removed.</p> <p>Open valve or remove obstruction in return line.</p>
Short filter cycles.	<ol style="list-style-type: none"> 1. Improper element cleaning 2. Pool chemistry not adequate to inhibit algae growth. 3. Flow rate too high. 	<p>Clean until all debris is removed.</p> <p>Maintain pool chemistry or consult pool service technician.</p> <p>Restrict flow to capacity of filter.</p>
Return flow to pool diminished, low filter pressure.	<ol style="list-style-type: none"> 1. Obstruction in the pump hair and lint pot. 2. Obstruction in pump. 3. Obstruction in suction line to pump. 	<p>Clean basket in strainer.</p> <p>Disassemble and clean pump.</p> <p>Clean skimmer basket. Remove obstruction in lines.</p> <p>Open valves in suction line.</p>

Notes



P/N 196043 Rev A



DE Element Filter

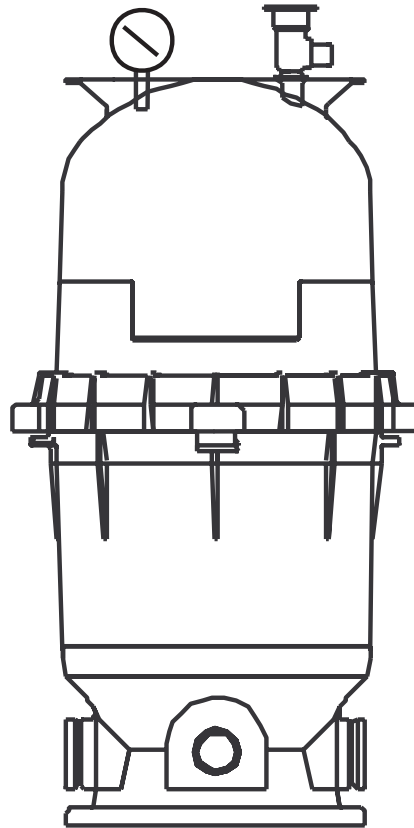

Installation and User's Guide

IMPORTANT SAFETY INSTRUCTIONS
READ AND FOLLOW ALL INSTRUCTIONS
SAVE THESE INSTRUCTIONS

Technical Support

Sanford, North Carolina (8 A.M. to 5 P.M. ET)

Moorpark, California (8 A.M. to 5 P.M. PT)

Phone: (800) 831-7133

Fax (800) 284-4151

Web sites: visit www.pentairpool.com and staritepool.com

Contents

Warnings and Important Safety Precautions.....	i
Section 1: Filter Overview	1
Section 2: Installation	2
Section 3: Operation and Maintenance	6
Initial Start-Up	6
Lock ring Installation	8
Filter Restart	9
Cleaning the Filter	10
Replacing Filter Element	11
Cleaning the High Flow™ Manual Air Relief Valve	11
Winterizing the System	13
Technical Data and Replacement Parts	13
Section 4: Troubleshooting	14

© 2009 Pentair Water Pool and Spa, Inc. All rights reserved

This document is subject to change without notice

1620 Hawkins Ave., Sanford, NC 27330 • (919) 566-8000
10951 West Los Angeles Ave., Moorpark, CA 93021 • (805) 553-5000

Pentair Water Pool and Spa® and High Flow™ are registered trademarks and/or trademarks of Pentair Water Pool and Spa, Inc. and/or its affiliated companies in the United States and/or other countries. Baquacil® and Baqua® are registered trademarks of Arch Chemicals, Inc. Unless noted, names and brands of others that may be used in this document are not used to indicate an affiliation or endorsement between the proprietors of these names and brands and Pentair Water Pool and Spa, Inc. Those names and brands may be the trademarks or registered trademarks of those parties or others.

P/N 196042 Rev A - 12/07/09

DE Element Filter Installation and User's Guide

WARNINGS AND IMPORTANT SAFETY PRECAUTIONS

⚠ DANGER SERIOUS BODILY INJURY OR DEATH CAN RESULT IF THIS FILTER IS NOT INSTALLED AND USED CORRECTLY.

⚠ DANGER INSTALLERS, POOL OPERATORS AND POOL OWNERS MUST READ THESE WARNINGS AND ALL INSTRUCTIONS BEFORE USING THIS DE ELEMENT FILTER.

⚠ WARNING This filter is intended for use in swimming pool applications.

⚠ WARNING Most states and local codes regulate the construction, installation, and operation of public pools and spas, and the construction of residential pools and spas. It is important to comply with these codes, many of which directly regulate the installation and use of this product. Consult your local building and health codes for more information.



IMPORTANT NOTICE - Attention Installer: This Installation and User's Guide ("Guide") contains important information about the installation, operation and safe use of this DE element filter. This Guide should be given to the owner and/or operator of this equipment.

⚠ WARNING Before installing this product, read and follow all warning notices and instructions in this Guide. Failure to follow warnings and instructions can result in severe injury, death, or property damage. Call (800) 831-7133 for additional free copies of these instructions. Please refer to www.pentair.com for more information related to this product.

⚠ DANGER Water temperature in excess of 100° F (37.7° C) may be hazardous to your health. Prolonged immersion in hot water may induce hyperthermia. Hyperthermia occurs when the internal temperature of the body reaches a level several degrees above normal body temperature of 98.6° F. (37° C.). Effects of hyperthermia include: (1) Unawareness of impending danger. (2) Failure to perceive heat. (3) Failure to recognize the need to leave the spa. (4) Physical inability to exit the spa. (5) Fetal damage in pregnant women. (6) Unconsciousness resulting in danger of drowning. The use of alcohol, drugs, or medication can greatly increase the risk of fatal hyperthermia in hot tubs and spas.



⚠ WARNING To reduce the risk of injury, do not permit children to use or operate this DE element filter.

⚠ WARNING When setting up pool water turnovers or flow rates the operator must consider local codes governing turnover as well as disinfectant feed ratios.

DO NOT increase pump size; this will increase the flow rate through the system and may exceed the maximum flow rate stated on the drain cover.

⚠ WARNING For filters intended for use in other than single-family dwellings, a clearly labeled emergency switch shall be provided as part of the installation.

⚠ WARNING The switch shall be readily accessible to the occupants and shall be installed at least 5 feet (1.52 m) away, adjacent to, and within sight of, the filter.

WARNINGS AND IMPORTANT SAFETY PRECAUTIONS



DANGER High Pressure from the Filter can cause severe injury or major property damage due to tank separation.

Release all pressure and read instructions before working on the DE element filter.

If the Lock Ring is adjusted under pressure, the tank can separate, causing serious injury or major property damage.



BEFORE WORKING ON FILTER!

- (1) Stop pump.
- (2) Open air relief valve.
- (3) Release all pressure from system.



RISK OF ELECTRICAL SHOCK OR ELECTROCUTION:

PUMPS REQUIRE HIGH VOLTAGE WHICH CAN SHOCK, BURN, OR CAUSE DEATH. BEFORE WORKING ON PUMP!

Always disconnect power to the pool pump at the circuit breaker from the pump before servicing the pump. Failure to do so could result in death or serious injury to service person, pool users or others due to electric shock.



A pool or spa pump must be installed by a qualified pool and spa service professional in accordance with the National Electrical Code and all applicable local codes and ordinances. Improper installation may create an electrical hazard which could result in death or serious injury to pool users, installers, or others due to electrical shock, and may also cause damage to property.



Pumps are not a substitute for properly installed and secured pool drain covers. An ANSI/ASME A112.19.8 approved anti-entrapment drain cover must be used for each drain. Pools and spas should utilize a minimum of two drains per pump. If a drain cover becomes loose, broken or is missing, close the pool or spa immediately and shut off the pump until an approved anti-entrapment drain cover is properly installed with the manufacturer's supplied screws.

For information about the Virginia Graeme Baker Pool and Spa Safety Act, contact the Consumer Product Safety Commission at (301) 504-7908 or visit www.cpsc.gov.

Important Note: Always turn off all power to the pool pump before installing the cover or working on any suction outlet.

Section 1

Filter Overview

Your high rate Diatomaceous Earth (DE) filter is designed to filter out particles as small as five microns to produce clear, sparkling water. The DE filter element life will vary with pool conditions such as bather load, wind, dust, etc. Water enters the filter through the “inlet” port at the bottom of the filter and is distributed evenly across the DE filter element. The dirt is removed by the element and the clean water flows through the “outlet” port at the bottom of the tank. The clean water is then returned to the pool through the piping or hoses.

⚠ WARNING

This filter operates under high pressure. When any part of the circulating system (e.g., clamp, pump, filter, valves, etc.) is serviced, air can enter the system and become pressurized. Pressurized air can cause the lid or lock ring to separate which may result in serious injury, death, or property damage. To avoid this potential hazard, follow these instructions.

1. Before the assembly, disassembly, or adjustment of the lid, or lock ring or any other service of the circulating system:
 - (a) Turn the pump off and shut off any automatic controls to ensure the system is not inadvertently started during the servicing;
 - (b) Open manual air relief valve;
 - (c) Wait until all pressure is relieved, pressure gauge must read zero (0).
2. Whenever installing the filter lock ring, follow the filter lid and lock ring installation instructions exactly.
3. Once service on the circulating system is complete, follow system restart instructions exactly.
4. Maintain circulation system properly. Replace worn or damaged parts immediately (e.g., lock ring, pressure gauge, relief valve, o-rings, etc.).
5. Be sure that the filter is properly mounted and positioned according to instructions provided.

After a period of time, dirt will accumulate in the filter element causing a resistance to the flow of water through the filter. This resistance results in a diminished flow of water and a rise in the pressure of the filter. Eventually the filter element will have removed so much dirt and the filter pressure risen to such a point that it will be necessary to clean your filter.

The filter's function is to remove suspended matter from the water. It does not sanitize the water. For sparkling clear water, the water must be sanitized as well as balanced. Pool chemistry is a specialized area, and you should consult your local pool service specialist for specific details. In general, proper pool sanitation requires a free chlorine level of 1 to 2 PPM and a pH range of 7.2 to 7.6. Your filtration system should be designed to meet your local health codes. As a minimum, you must be sure that your system will turnover the total volume of water in your pool at least twice in a twenty-four hour period.

⚠ WARNING

Failure to operate your filter system or inadequate filtration can cause poor water clarity obstructing visibility in your pool. Poor water clarity may obscure objects in the water which while swimming and diving could cause serious personal injury or death. Never swim in a pool with poor water clarity.

Section 2

Installation

1. **Read and understand all instructions before attempting to install, operate or maintain your pump and DE filter system.**
2. Provide space and lighting for routine maintenance access. Locate the system close to the pool. Install electrical controls (e.g., on/off switches, timers, control systems, etc.) at least five (5) feet from the filter. This will allow you enough room to stand clear of the filter during system start up.
3. Remove all individual components from carton and inspect for any visible damage. If carton or parts are damaged contact seller or freight company.

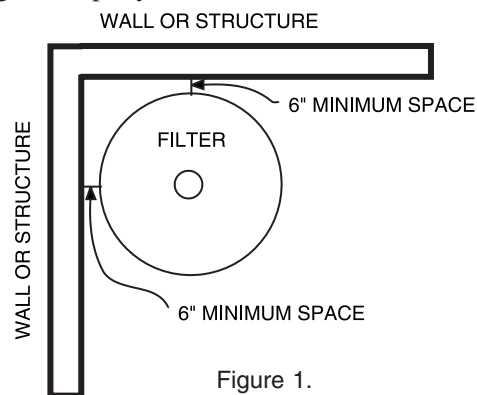

⚠ WARNING Blockage of suction fittings can cause serious or fatal injury due to drowning. To reduce the risk of injury, do not permit children to use this product.

⚠ WARNING Never work on the pump while it is running or power is still connected. High voltage can cause serious or fatal injury. A suitable ground fault interrupter (GFCI) should always be installed at the power supply source of this unit. Be sure to ground the motor before connecting to electrical AC power supply. Failure to ground the motor can cause serious or fatal electrical shock hazard. **DO NOT** ground to a gas supply pipe line.

4. The filter should be mounted on a level concrete slab. Position the filter so that the instructions, warnings and pressure gauge are visible to the operator. Also, position the filter so that the piping connections and drain port are convenient and accessible for servicing and winterizing.
5. Install electrical controls (e.g., on/off switches, timers control systems, etc.) at least five (5) feet from the filter. This will allow you enough room to stand clear of the filter during system start up.
6. Provide sufficient clearance around the filter to permit visual verification that the lock ring is properly installed, see Figure 1.
7. Provide sufficient space above the filter to remove the filter lid or for cleaning and servicing. This distance will vary with the model of filter you are using. See Table 1 below for the required vertical clearance.

⚠ DANGER Risk of electrical shock or electrocution. Position the filter and High Flow™ manual air relief valve to safely direct water drainage and purged air or water. Water discharged from an improperly positioned filter or valve can create an electrical hazard that can cause severe personal injury as well as damage property.



Table 1.

Model	Size	Required vertical clearance
ECDE60	15 sq. ft	36 in
ECDE90	30 Sq. ft	68 in

8. When installing the High Flow™ manual air relief valve use the O-ring only, there is no need for thread sealing compounds. Position the filter to safely direct water drainage. Rotate the High Flow™ manual air relief valve to safely direct purged air or water. Water discharged from an improperly positioned filter or valve can create an electrical hazard as well as damage property.
9. Make all plumbing connections in accordance with local plumbing and building codes. Filter plumbing connections are provided with an O-ring seal. Use only a silicone base lubricant on the O-rings. Do not use pipe joint compound, glue or solvent on the bulkhead connections.
10. The base of this filter is provided with two (2) mounting bosses for the purpose of anchoring the filter to the concrete.
11. The maximum working pressure of this filter is 50 psi. Never subject this filter to pressure in excess of this amount, even when conducting hydrostatic pressure tests. Pressures above 50 psi can cause the lid to separate, which can result in severe injury, death or property damage.

When performing hydrostatic pressure tests or when testing for external leaks of the completed filtration and plumbing system, insure that the Maximum Pressure that the filtration system will be subjected to DOES NOT EXCEED THE MAXIMUM WORKING PRESSURE OF ANY OF THE COMPONENTS CONTAINED WITHIN THE SYSTEM. In most cases, the maximum pressure will be stated on each component of the system.



High Pressure:
Improper tank lid and lock ring assembly could cause the lid to separate and cause serious injury and/or major property damage.

If doubt exists as to the pressure to which the system will be subjected, install an ASME approved automatic Pressure Relief or Pressure Regulator in the circulation system for the lowest working pressure of any of the components in the system.

12. Use sealant on all tapered male connections of pipes and fittings. Use only sealant compounds suited for plastic pipe. Support pipe to prevent strains on filter, pump or valve. **DO NOT USE PETROLEUM BASED PRODUCTS.**
13. Install pressure gauge in 1/4" NPT port located in the tank lid.
14. Never store pool chemicals within ten (10) feet of your pool filter or pump. Pool chemicals should always be stored in a cool, dry, well ventilated area.

⚠ WARNING Chemical fumes and/or spills can cause serious corrosion to the filter and pump structural components. Structurally weakened components can cause filter, pump or valve attachments to separate and could cause serious bodily injury or property damage.

⚠ WARNING The system's centrifugal pump operates with electrical voltage, and can generate both vacuum and pressure in the water system. When properly wired and plumbed, this pump will operate in a safe manner.

⚠ WARNING High voltage can cause serious or fatal injury. Always install a suitable GFCI at the power source of this unit as an added safety precaution. Article 681-31 of the NEC requires that a GFCI be used if this pump is used with a storable pool.

15. Avoid over tightening the pipe threads when connecting fittings to the pump or filter. Proper procedure is to apply a pipe sealant to the thread and then install hand tight plus one turn. **DO NOT OVER TIGHTEN.**

Section 3

Operation and Maintenance

Initial Start-Up

1. This filter operates under pressure. When the lock ring is installed properly and operated without air in the water system, this filter will operate in a safe manner.
2. The maximum working pressure of this filter is 50 psi. Never subject this filter to pressure in excess of this amount - even when conducting hydrostatic pressure tests. Pressures above 50 psi can cause the lid to separate, which can result in severe injury, death or property damage. When performing hydrostatic pressure tests or when testing for external leaks of the completed filtration and plumbing system, insure that the Maximum Pressure that the filtration system will be subjected to **DOES NOT EXCEED THE MAXIMUM WORKING PRESSURE OF ANY OF THE COMPONENTS CONTAINED WITHIN THE SYSTEM.** In most cases, the maximum pressure will be stated on each component of the system. If you are not sure what the system pressure will be, install an ASME approved automatic Pressure Relief or Pressure Regulator in the circulation system for the lowest working pressure of any of the components in the system.

	<p>This filter operates under pressure. With the lock ring and lid installed properly and operated without air in the system, this filter will operate in a safe manner. Air entering the filter and the lock ring or lid not installed correctly can cause the lid to separate, which could cause serious personal injury and/or property damage.</p>
---	--

	<p>DO NOT attempt to disassemble or adjust the filter unless you fully understand it's operation. Serious injury or death can occur if the equipment is improperly handled. Consult a pool service professional for maintenance and service assistance.</p>
---	--

1. Be sure all connections have been made and are secure.
2. Make sure the hair and lint pot of the pump is filled with water.
FAILURE TO FILL THE HAIR AND LINT POT WITH WATER WILL RESULT IN DAMAGE TO THE PUMP AND PUMP SEAL.
3. **OPEN THE HIGH FLOW MANUAL AIR RELIEF VALVE UNTIL IT SNAPS INTO THE FULL OPEN POSITION. THIS ONLY REQUIRES A ¼ TURN COUNTERCLOCKWISE.**

4. **STAND CLEAR OF THE FILTER.** Start the pump allowing the filter tank to fill with water. Close the High Flow manual air relief valve after a steady stream of water appears.
5. Remove the skimmer lid, put the recommended amount of diatomaceous earth (D.E) into the skimmer. The D.E. will be drawn into the filter and deposited evenly upon the element cartridge. Now the filter is providing the pool with bright, clean water.

NOTE: DO NOT OPERATE FILTER WITHOUT D.E. CHARGE FOR MORE THAN TWO MINUTES. DO NOT USE MORE THAN THE RECOMMENDED AMOUNT OF D.E. IN YOUR FILTER.

REGENERATIVE D.E. RECOMMEDATION

The amount of D.E. should be between one (1) and two (2) pounds for each 10 square feet of filter area or:

MODEL	Pounds of D.E.
ECDE60	1.5
ECDE90	3.0

6. Your filter has now started its filter cycle. You should check that the water is returning to the pool and take note of the operating pressure.
7. Check the system for water leaks. If a leak is found, shut off pump before correcting leak.
8. The pressure gauge is the primary indicator of how the filter is operating. Maintain your pressure gauge in good working order.
9. Clean your filter when pressure reads between 8-10 psi higher than the original starting pressure. Your filter pressure reading will increase as it removes dirt from your pool. However, this buildup of pressure will vary due to different bathing loads, temperature, weather conditions, etc.
 - a. MY ORIGINAL STARTING PRESSURE IS _____ psi (pounds per square inch). I SHOULD CLEAN THE FILTER DE ELEMENT AT _____ psi.

LOCK RING INSTALLATION

These instructions **MUST BE FOLLOWED EXACTLY** to prevent the lid from separating during system restart or later operation.

1. Perform the following steps before working on any part of the circulating system (e.g., lock ring, pump, filter, valves, etc.).
 - a. Turn the pump off and shut off any automatic controls to ensure that the system is not inadvertently started during servicing.
 - b. Open the air relief valve.
 - c. Wait until all pressure is relieved. **Never attempt to assemble, disassemble or adjust the filter lock ring while there is any pressure in the filter.**
2. Be certain the O-ring is in position in the lower tank half. Place the filter lid over the lower tank half. Making sure it is fully and firmly seated on the tank half, see Figure 2 on page 8.

⚠ DANGER This filter operates under pressure. With the lock ring and lid installed properly and operated without air in the system, this filter will operate in a safe manner. Air entering the filter and the lock ring or lid not installed correctly can cause the lid to separate, which could cause serious personal injury and/or property damage.



⚠ DANGER **THIS FILTER OPERATES UNDER HIGH PRESSURE. WHEN ANY PART OF THE CIRCULATING SYSTEM (e.g., LOCK RING, PUMP, FILTER, VALVES, ETC.) IS SERVICED, AIR CAN ENTER THE SYSTEM AND BECOME PRESSURIZED. PRESSURIZED AIR CAN CAUSE THE LID TO SEPARATE WHICH CAN RESULT IN SEVERE INJURY, DEATH, OR PROPERTY DAMAGE. TO AVOID THIS POTENTIAL HAZARD, FOLLOW THESE INSTRUCTIONS.**



3. Place lock ring over tank lid, and centering the lock ring on the threads of the tank body, turn the lock ring clockwise until the safety latches click and the lock ring hits the stops on the body. **DO NOT ATTEMPT TO OVER-TIGHTEN THE LOCK RING AFTER LOCK RING HAS HIT THE STOPS ON THE BODY.**
4. Proceed to **“Filter Restart”** on page 9.

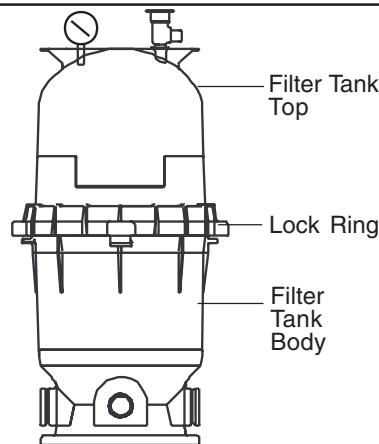



Figure 2.

FILTER RESTART

	<p>⚠ DANGER THIS FILTER OPERATES UNDER HIGH PRESSURE. WHEN ANY PART OF THE CIRCULATING SYSTEM (e.g., LOCK RING, PUMP, FILTER, VALVES, ETC.) IS SERVICED, AIR CAN ENTER THE SYSTEM AND BECOME PRESSURIZED. PRESSURIZED AIR CAN CAUSE THE LID TO SEPARATE WHICH CAN RESULT IN SEVERE INJURY, DEATH, OR PROPERTY DAMAGE. TO AVOID THIS POTENTIAL HAZARD, FOLLOW THESE INSTRUCTIONS.</p>
---	---

1. **Open the High Flow™ manual air relief valve until it snaps into the full open position (this only requires a quarter turn counterclockwise).** Opening this valve rapidly releases air trapped in the filter.
2. Stand clear of the filter tank, then start the pump.
3. Close the High Flow™ manual air relief valve after a steady stream of water appears.
4. The system is not working properly if either of the following conditions occur.
 - a. A solid stream of water does not appear within 30 seconds, after the pump's inlet basket fills with water.
 - b. The pressure gauge indicates pressure before water outflow appears.

If either condition exists, **shut off the pump immediately**, open valves in the water return line to relieve pressure, and clean the air relief valve, see “Cleaning the High Flow™ Manual Air Relief Valve” on page 11. If the problem persists, call Technical Support (1-800-831-7133) for assistance.

<p>⚠ WARNING</p>	<p>The following information should be read carefully since it outlines the proper manner of care and operation for your filter system. As a result of following these instructions and taking the necessary preventative care, you can expect maximum efficiency and life from your filtration system.</p>
-------------------------	---

⚠ CAUTION

Please heed all manufacturers' posted instructions, warnings and cautions when using Baquacil® or Baqua Clean®.

CLEANING THE FILTER

1. Turn the pump off, shut off any automatic controls to ensure that the system is not inadvertently started during servicing.
2. Open the filter High Flow™ manual air relief valve, (and the waste drain valve, or cap, if your system has one).

NOTE: Special care must be taken when cleaning the filter element used in a swimming pool or spa using Baquacil® as a sanitizer. Because of the way Baquacil works, the filter media must be cleaned more thoroughly and more frequently than in a chlorine system. If extreme care is not taken to completely remove all residue from the filter element a buildup will occur. This buildup will significantly shorten the life of the filter element. Baquacil is a mild coagulant which combines bacterial cells as well as other small particles contributed by the environment, bathers, etc. into particles large enough to be trapped by the filter. In comparison with all other trapped contaminants in a typical pool or spa the amount of bacterial cells that are deposited on the filter is minimal. The resulting deposit is a gray sticky film which can only be removed with Baqua® Clean. If TSP or any TSP type cleaner is used prior to stripping the film, the cleaner and the gray film will combine to form a gum-like substance. Once this occurs, the substance cannot be removed from the media and the filter media must be replaced.

3. Remove hair and lint strainer pot lid and clean basket. Replace basket and secure lid.
4. Disconnect air relief drain hose if installed.
5. Remove locking ring by depressing safety latches on both sides of ring and rotate counterclockwise, then remove tank lid.
6. Remove the DE Cartridge style element assembly by placing hands in lifting handles and pulling straight up on the element assembly.
7. Using a garden hose with a nozzle, direct water spray at the element to dislodge and wash away accumulated foreign matter.
8. Clean and remove debris from inside the filter tank and from O-ring and O-ring groove on tank body.
9. Replace the clean element assembly into the filter tank body, making sure it is fully seated. Align the arrow on the handle frame with inlet port of filter.

10. Replace the tank lid onto the tank body making sure it is fully and firmly seated on the tank body.
11. Place lock ring over tank lid, and centering the lock ring on the threads of the tank body, turn the lock ring clockwise until the safety latches click and the lock ring hits the stops on the body. **DO NOT ATTEMPT TO OVER-TIGHTENED THE LOCK RING AFTER LOCK RING HAS HIT THE STOPS ON THE BODY.**

⚠ CAUTION

Any time the filter tank is opened, and/or element assembly is removed, be sure to generously coat the O-ring with silicone lubricant before reassembling the unit. **DO NOT USE PETROLEUM BASED LUBRICANTS BECAUSE THEY HAVE A DETERIORATING EFFECT ON RUBBER.**

12. Replace drain cap and reinstall air relief valve drain hose if used.

REPLACING FILTER ELEMENT

Element life will vary with pool conditions such as bather load, wind, dust, etc. You can expect an average media life of three years under normal conditions.

1. To replace the element, follow “Cleaning The Filter” instructions on page 10.

CLEANING THE HIGH FLOW MANUAL™ AIR RELIEF VALVE

1. Turn the pump off and shut off any automatic controls to ensure that the system is not inadvertently started during servicing.
2. **OPEN THE HIGH FLOW™ MANUAL AIR RELIEF VALVE UNTIL IT SNAPS INTO THE FULL OPEN POSITION, THEN WAIT UNTIL ALL PRESSURE IS RELIEVED.**
3. With the relief valve attached to the filter tank, pull out the locking tabs and remove the valve stem and cover assembly with a counterclockwise and lifting motion, see Figure 3 on page 12.

4. Clean debris from the valve stem and body. Verify that the filter tank's air passage is open by inserting a 5/16" drill bit through the valve body. Verify that the O-rings are in good condition, properly positioned, and lubricated with a silicone base lubricant.
5. Reinstall the valve stem and cover assembly with a downward and clockwise motion until it snaps into position.

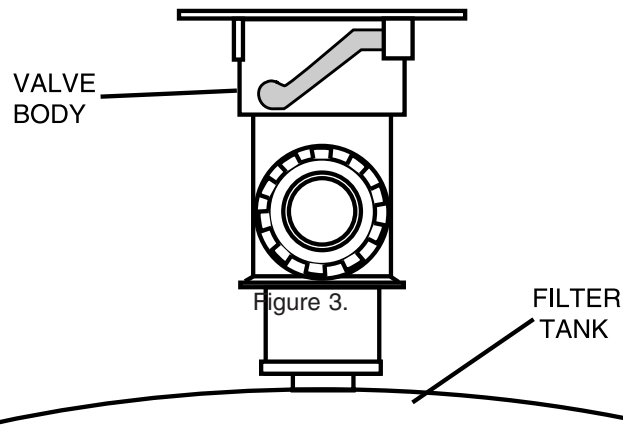
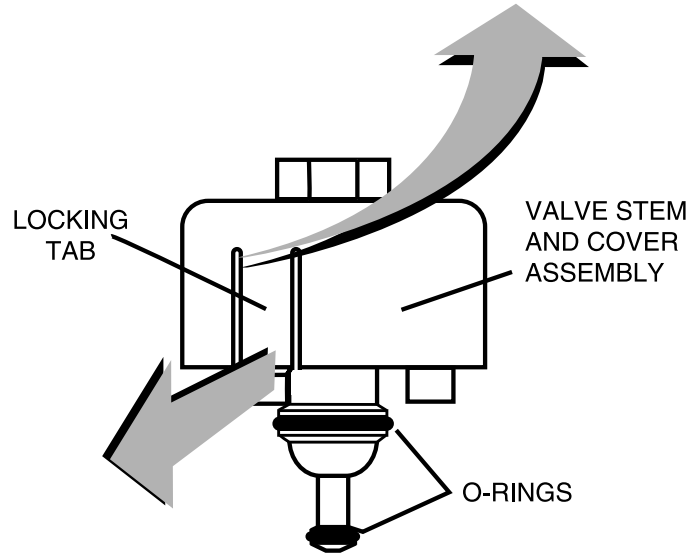

Figure 3.

Winterizing the System

CAUTION Allowing water to freeze in the system will damage the system and cause potential water damage/flooding and potential property damage.

1. In areas that have freezing winter temperatures, the pool equipment must be winterized to protect it from damage.
2. Open the High Flow™ manual relief valve.
3. Remove the drain port cap at the bottom of the filter.

IMPORTANT NOTE: Remove drain port cap for draining water from filter. Leave the drain port cap off and store it during the time the system is shut down.

4. Drain all appropriate system piping.
5. It is recommended that the pump and filter be covered with a tarpaulin or plastic sheet to inhibit deterioration from the weather. DO NOT wrap the pump motor with plastic.
6. In installations where the pump cannot be drained a 40% Propylene Glycol 60% water solution will protect to -50° F (-45.5° C)

Note: Do not use anti-freeze solutions except Propylene Glycol; as other anti-freeze are highly toxic and will damage the pump.

Technical Data and Replacement Parts

Note
Please see the provided insert sheet for Technical Data and Replacement Parts information specific to your Filter.

Troubleshooting

- A. Air entering your filter is dangerous and can cause the lid to separate. Correct any conditions in your filtration system that allows air to enter the system.
1. Some common ways to identify air entering the system:
 - a. Low water level in pool or spa - skimmer is starving for water with pump running. Add water to pool or spa.
 - b. Air bubbles or low water level in pump hair and lint pot are caused by; low water level, clogged skimmer basket, split suction cleaner hose, leak in pump hair and lint pot lid, or leak in pump suction line.
 - c. Air bubbles coming out of water return lines into pool or spa with pump running, see items 1.a and 1.b of this section.
 - d. Air is discharged from the air relief valve on top of the filter when the valve is opened with the pump running, see items 1.a and 1.b of this section, above.
- B. Until the water initially put into the pool has been completely filtered, short filter cycles in between cleanings are normal. In most cases pool owners are dismayed by the undesirable color and appearance of water in a newly filled pool. Plaster dust can be responsible for short filter cycles, requiring frequent cleaning.
- C. If pressure drops on gauge, check skimmer basket and pump basket first for debris. If the baskets are clean, shut off power to pump and turn off any automatic controls. Then turn motor shaft with your fingers. If it turns freely then the pump must be disassembled and the impeller checked to see if it is clogged. If it is not frozen or clogged then there is an obstruction in the line between the pool and the pump.
- D. The pressure gauge is an important part of the filter system. It is your primary indicator of how the system is operating. Maintain your pressure gauge in good working order. Check the operation of your pressure gauge in the following manner:
1. The pressure gauge should go to zero (0) when the system is turned off and pressure is relieved.
 2. The pressure gauge should indicate pressure when the system is operating.
 3. The pressure gauge should be readable and not damaged in any way.
 4. Replace the pressure gauge if it is not meeting the requirements of items D.1 through D.3 of this section, above.

Problem	Cause	Action
Pool water not sufficiently clean.	<ol style="list-style-type: none"> 1. Pool chemistry not adequate to inhibit algae growth. 2. Too frequent an element cleaning cycle. 3. Inadequate turnover rate. 	<p>Maintain pool chemistry or consult service technician.</p> <p>Allow pressure to build to 10psi above clean filter condition before cleaning element.</p> <p>Run system for longer time or consult dealer or pool service technician.</p>
Higher filter pressure.	<ol style="list-style-type: none"> 1. Insufficient element cleaning 2. Partially closed valve or restriction. 	<p>Clean until all debris is removed.</p> <p>Open valve or remove obstruction in return line.</p>
Short filter cycles.	<ol style="list-style-type: none"> 1. Improper element cleaning 2. Pool chemistry not adequate to inhibit algae growth. 3. Flow rate too high. 	<p>Clean until all debris is removed.</p> <p>Maintain pool chemistry or consult pool service technician.</p> <p>Restrict flow to capacity of filter.</p>
Return flow to pool diminished, low filter pressure.	<ol style="list-style-type: none"> 1. Obstruction in the pump hair and lint pot. 2. Obstruction in pump. 3. Obstruction in suction line to pump. 	<p>Clean basket in strainer.</p> <p>Disassemble and clean pump.</p> <p>Clean skimmer basket. Remove obstruction in lines.</p> <p>Open valves in suction line.</p>



P/N 196042 Rev A