

Practice Multiple-Choice Tests

Your Signature (do not print): _____

Print Your Name Here: _____

Your Date of Birth:									
<input type="text"/>	<input type="text"/>	-	<input type="text"/>	<input type="text"/>	-	<input type="text"/>	<input type="text"/>	<input type="text"/>	<input type="text"/>
Month		Day		Year					

Form 0661C

2007 | 2008 ACT ASSESSMENT[®]

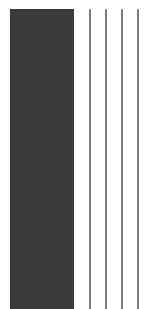

Directions

This booklet contains tests in English, Mathematics, Reading, and Science. These tests measure skills and abilities highly related to high school course work and success in college. ***CALCULATORS MAY BE USED ON THE MATHEMATICS TEST ONLY.***

The questions in each test are numbered, and the suggested answers for each question are lettered. On the answer document, the rows of ovals are numbered to match the questions, and the ovals in each row are lettered to correspond to the suggested answers.

For each question, first decide which answer is best. Next, locate on the answer document the row of ovals numbered the same as the question. Then, locate the oval in that row lettered the same as your answer. Finally, fill in the oval completely. Use a soft lead pencil and make your marks heavy and black. ***DO NOT USE A BALLPOINT PEN.***

Mark only one answer to each question. If you change your mind about an answer, erase your first mark thoroughly before marking your new answer. For each question, make certain that you mark in the row of ovals with the same number as the question.

Only responses marked on your answer document will be scored. Your score on each test will be based only on the number of questions you answer correctly during the time allowed for that test. You will NOT be penalized for guessing. ***IT IS TO YOUR ADVANTAGE TO ANSWER EVERY QUESTION EVEN IF YOU MUST GUESS.***

You may work on each test ONLY when your test supervisor tells you to do so. If you finish a test before time is called for that test, you should use the time remaining to reconsider questions you are uncertain about in that test. You may NOT look back to a test on which time has already been called, and you may NOT go ahead to another test. To do so will disqualify you from the examination.

Lay your pencil down immediately when time is called at the end of each test. You may NOT for any reason fill in or alter ovals for a test after time is called for that test. To do so will disqualify you from the examination.

Do not fold or tear the pages of your test booklet.

**DO NOT OPEN THIS BOOKLET
UNTIL TOLD TO DO SO.**



ENGLISH TEST

45 Minutes—75 Questions

DIRECTIONS: In the five passages that follow, certain words and phrases are underlined and numbered. In the right-hand column, you will find alternatives for the underlined part. In most cases, you are to choose the one that best expresses the idea, makes the statement appropriate for standard written English, or is worded most consistently with the style and tone of the passage as a whole. If you think the original version is best, choose “NO CHANGE.” In some cases, you will find in the right-hand column a question about the underlined part. You are to choose the best answer to the question.

You will also find questions about a section of the passage, or about the passage as a whole. These questions do not refer to an underlined portion of the passage, but rather are identified by a number or numbers in a box.

For each question, choose the alternative you consider best and fill in the corresponding oval on your answer document. Read each passage through once before you begin to answer the questions that accompany it. For many of the questions, you must read several sentences beyond the question to determine the answer. Be sure that you have read far enough ahead each time you choose an alternative.

PASSAGE I

The Music of the O’odham

[1]

For some people, traditional American Indian music is associated and connected¹ with high penetrating vocals accompanied by a steady drumbeat. In tribal communities in the southwestern United States, however, one is likely to hear something similar to the polka-influenced dance music of northern Mexico. The music is called “waila.” Among the O’odham tribes of Arizona, waila has been popular for² more than a century. The music is mainly instrumental—the bands generally³ consist of guitar, bass guitar, saxophones, accordion, and drums.

[2]

Unlike some traditional tribal music, waila does not serve a religious or spiritual purpose. It is a social music that performed⁴ at weddings, birthday parties,

1. A. NO CHANGE
 B. connected by some of them
 C. linked by association
 D. associated
2. F. NO CHANGE
 G. popular, one might say, for
 H. really quite popular for
 J. popular for the duration of
3. Which of the following alternatives to the underlined portion would NOT be acceptable?
 A. instrumental; in general, the bands
 B. instrumental, the bands generally
 C. instrumental. The bands generally
 D. instrumental; the bands generally
4. F. NO CHANGE
 G. music in which it is performed
 H. music, performing
 J. music, performed



and feasts. The word itself⁵ comes from the Spanish

word for dance, *baile*. Cheek to cheek, the dance is⁶
performed to the relaxed two-step tempo, and the bands⁶

often play long past⁷ midnight. As the dancers step to the

music, they were also stepping⁸ in time to a sound that

embodies their⁹ unique history and suggests the influence

of outside cultures on their music. 10

[3]

The O'odham in the 1700s¹¹ first encountered the
guitars of Spanish missionaries. In the 1850s the O'odham

have borrowed¹² from the waltzes and mazurkas of
people of European descent on their way to California.

5. A. NO CHANGE
B. word, itself,
C. word, itself
D. word itself,
6. F. NO CHANGE
G. Couples dance cheek to cheek to the relaxed two-step tempo,
H. A relaxed two-step tempo, the couples dance cheek to cheek,
J. Cheek to cheek, the two-step tempo relaxes dancing couples,
7. A. NO CHANGE
B. play long, past,
C. play, long past,
D. play, long past
8. F. NO CHANGE
G. are also stepping
H. have also stepped
J. will also step
9. A. NO CHANGE
B. they're
C. it's
D. its'
10. At this point, the writer is considering adding the following true statement:
The agricultural practices of the O'odham are similar to those of the Maya.
Should the writer make this addition here?
F. Yes, because the sentence establishes that the O'odham often borrowed ideas from other groups.
G. Yes, because the sentence provides important information about the O'odham people.
H. No, because the sentence is not supported by evidence of a connection between the O'odham and the Maya.
J. No, because the sentence distracts from the paragraph's focus on waila's uses and influences.
11. All of the following would be acceptable placements for the underlined portion EXCEPT:
A. where it is now.
B. at the beginning of the sentence (revising the capitalization accordingly).
C. after the word *guitars*.
D. after the word *missionaries* (ending the sentence with a period).
12. F. NO CHANGE
G. have been borrowing
H. were borrowed
J. borrowed



In the early 1900s the O’odham became acquainted with marching bands and woodwind instruments (which explains the presence of saxophones in waila).¹³ Around this time the polka music and button accordion

played by German immigrant railroad workers; left their mark on waila.¹⁴

[4]

It should be no surprise that musicians these days are adding touches of rock, country, and reggae to waila. Some listeners fear that an American musical form may soon be lost. But the O’odham are playing waila with as much energy and devotion as ever. A unique blend of traditions, waila will probably continue changing for as long as the O’odham use it to express their own sense of harmony and tempo.

PASSAGE II

How Old Am I?

Many people might be surprised to learn that the American way of computing a person’s age differs from the traditional Korean way. In Korean tradition, a person is considered to be already one year old at the time of his or her birth.

As a child growing up in two cultures, I found this contest a bit confusing. When I was in the fifth grade, was I ten or eleven years old? To add to the confusion, every New Year’s Day a person according to this Korean counting system, becomes a year

13. Given that all of the choices are true, which one is most relevant to the focus of this paragraph?
- A. NO CHANGE
 - B. (although fiddles were once widely used in waila bands).
 - C. (even though they’re now often constructed of metal).
 - D. (which are frequently found in jazz bands also).
14. F. NO CHANGE
- G. workers
 - H. workers;
 - J. workers,

Question 15 asks about the preceding passage as a whole.

15. Upon reviewing this essay and finding that some information has been left out, the writer composes the following sentence incorporating that information:
- Those same German influences helped spawn a similar musical form in northern Mexico known as *norteño*.
- This sentence would most logically be placed after the last sentence in Paragraph:
- A. 1.
 - B. 2.
 - C. 3.
 - D. 4.

16. F. NO CHANGE
- G. change
 - H. dispute
 - J. difference
17. A. NO CHANGE
- B. person,
 - C. person;
 - D. person who,



older, regardless of his or her actual birthday.

Birthdays are important throughout the world. A person ¹⁸ who is sixteen years old on his or her birthday in March would become seventeen years old on the following New Year's Day, even though he or she isn't expected to turn seventeen (in "American" years) until that next birthday in March. Perhaps the celebration of New Year's Day in Korean culture is heightened because it is thought of as ¹⁹

everyone's birthday party. 20

Today, after many birthdays and New Year's Days, I now find meaningful the difference I once found confusing. Otherwise, this difference points ²¹

to significant underlying cultural values. The practice of ²²

advancing a person's age seems to me to reflect the value a ²³

society places on life experience and longevity. Their idea ²⁴

was demonstrated often when my elderly relatives, who ²⁵ took pride in reminding younger folk of their "Korean

age." With great enthusiasm, they added on a year every ²⁶

18. F. NO CHANGE
G. Most cultures celebrate birthdays.
H. Birthdays focus attention on a culture's youth.
J. DELETE the underlined portion.

19. A. NO CHANGE
B. raised
C. lifted
D. lighted

20. Upon reviewing this paragraph, the writer considers deleting the preceding sentence. If the writer were to delete the sentence, the paragraph would primarily lose:
F. a comment on the added significance of the Korean New Year celebration.
G. a repetitive reminder of what happens every birthday.
H. a defense of the case for celebrating every birthday.
J. an illustration of the Korean counting system.

21. A. NO CHANGE
B. Though,
C. In fact,
D. Then,

22. F. NO CHANGE
G. on
H. at
J. DELETE the underlined portion.

23. A. NO CHANGE
B. persons' age
C. persons age
D. person's age,

24. F. NO CHANGE
G. One's
H. Its
J. This

25. A. NO CHANGE
B. by
C. while
D. as if

26. Which choice would most clearly communicate the elderly relatives' positive attitude toward this practice?
F. NO CHANGE
G. Duplicating an accepted practice,
H. Living with two birthdays themselves,
J. Obliging,



New Year's Day. By contrast American society has often been described as one that values the vibrant energy of

27

youth over the wisdom and experience gained with age. After a certain age, many Americans I know would

28

balk, refuse, and hesitate at the idea of adding a year or two to what they regard as their actual age.

29

Even something as visibly simple or natural as computing a person's age can prove to be not so clear-cut. Traditions like celebrating birthdays reveal how deeply we are affected by the culture we live in.

30

27. A. NO CHANGE

B. whose

C. this

D. whom

28. If the writer were to delete the phrases "the vibrant energy of" and "the wisdom and experience gained with" from the preceding sentence, the sentence would primarily lose:

F. its personal and reflective tone.

G. an element of humor.

H. details that illustrate the contrast.

J. the preference expressed by the writer.

29. A. NO CHANGE

B. balk and hesitate

C. refuse and balk

D. balk

30. F. NO CHANGE

G. apparently

H. entirely

J. fully

PASSAGE III

Wearing Jeans in School

In 1970, the school board in Pittsfield, New Hampshire, approved a dress code that prohibited students from wearing certain types of clothing. The school board members believed that wearing "play clothes" to school made the students

31

inefficient toward their school work, while more formal attire established a positive educational climate. When twelve-year-old Kevin Bannister wore a pair of blue jeans to school, he was sent home for violating the dress code.

32

31. Given that all of the choices are true, which one would best illustrate the term *dress code* as it is used in this sentence?

A. NO CHANGE

B. clothing that was inappropriate.

C. clothing, including sandals, bell-bottom pants, and "dungarees" (blue jeans).

D. clothing that is permitted in some schools today.

32. F. NO CHANGE

G. lazy and bored to tears with

H. blow off

J. lax and indifferent toward



Kevin and his parents believed that his constitutional
rights had been violated. ³³ The United States District
³³

Court of New Hampshire; agreed to hear Kevin's case.
³⁴
His claim was based on the notion of personal liberty—the
right of every individual to the control of his or her own
person—protected by the Constitution's Fourteenth
Amendment. The court agreed with Kevin that a person's
right for wearing clothing of his or her own choosing is,
³⁵
in fact, protected by the Fourteenth Amendment.

The court noted, however that restrictions may be justified
³⁶
in some circumstances, such as in the school setting.

So did Kevin have a right to wear blue jeans to
school? The court determined that the school board had
failed to show that wearing jeans actually inhibited the
educational process, which is guided by authority figures.
³⁷

Furthermore, the board offered no evidence to back up it's
³⁸

claim that such clothing created a negative educational
³⁹
environment. Certainly the school board would
be justified in prohibiting students from wearing
clothing that was unsanitary, revealing, or obscene.

33. Given that all of the choices are true, which one would most effectively introduce the main idea of this paragraph?

- A. NO CHANGE
- B. The principal said dungarees and blue jeans were the same thing, so Kevin should have known better.
- C. If Kevin's jeans had been dirty and torn, the principal might have been justified in expelling him.
- D. These events occurred in a time of social unrest, and emotions were running high.

34. F. NO CHANGE
G. Court, of New Hampshire
H. Court of New Hampshire
J. Court of New Hampshire,

35. A. NO CHANGE
B. of wearing
C. to wear
D. wearing

36. F. NO CHANGE
G. court noted, however,
H. court, noted however,
J. court noted however,

37. A. NO CHANGE
B. process, which has undergone changes since the 1970s.
C. process, a process we all know well.
D. process.

38. F. NO CHANGE
G. they're
H. its
J. ones

39. A. NO CHANGE
B. where
C. which
D. in which



The court remained unconvinced, therefore, that

40

when wearing jeans would actually impair the learning
process of Kevin or of his fellow classmates.

41

Kevin Bannister's case was significant in that it
was the first in the United States to address clothing
prohibitions of a school dress code. His challenge

42

42

42

initiated a review, of students' rights and administrative

43

responsibility in public education.

44

40. F. NO CHANGE
G. thus,
H. moreover,
J. however,

41. A. NO CHANGE
B. by wearing
C. wearing
D. having worn

42. Which choice would most effectively open this paragraph and convey the importance of this case?
F. NO CHANGE
G. Therefore, Kevin's case reminds us that you should stand up for your rights, no matter how old you are.
H. The case for personal liberty means the right to speak up must be taken seriously by the courts.
J. All in all, clothing is an important part of our identity.

43. A. NO CHANGE
B. review, of students' rights,
C. review of students' rights
D. review of students' rights,

44. F. NO CHANGE
G. on
H. with
J. about

Question 45 asks about the preceding passage as a whole.

45. Suppose the writer's goal had been to write a brief persuasive essay urging students to exercise their constitutional rights. Would this essay fulfill that goal?
A. Yes, because the essay focuses on how Kevin encouraged other students to exercise their constitutional rights.
B. Yes, because the essay focuses on various types of clothing historically worn by students as a freedom of expression.
C. No, because the essay suggests that the right to wear blue jeans was not a substantial constitutional right in the 1970s.
D. No, because the essay objectively reports on one case of a student exercising a particular constitutional right.



PASSAGE IV

The Case of the Trick Photographs

You might think that Sir Arthur Conan Doyle, the writer who invented Sherlock Holmes, the most logical of detectives, would have harbored strictly logical beliefs himself. But the author entertained a variety of fanciful ideas, including a belief in the mythical beings known as fairies. Since that belief, he was fooled in 1920 by two
46

schoolgirl cousins. 47

One day, Elsie Wright and Frances Griffiths returned from a walk in the English countryside with news that they had seen fairies. They had even taken photographs that showed several of the tiny sprites, some dancing in a ring in the grass, some fluttering in front of the girl's faces.
48
Many people were excited when they heard about

this seemingly true and factual proof of the existence of
49
fairies, but Conan Doyle was more excited than most.

To make sure that he wasn't being deceived, Conan Doyle had the original photographic plates examined by experts, however, they found no evidence of
50
double exposures. He then wrote an enthusiastic article for *Strand* magazine, being the place in which most of his
51
Sherlock Holmes stories had first appeared, and later wrote a book on the subject titled *The Coming of the Fairies*.

46. F. NO CHANGE
G. Because of
H. Concerning
J. For

47. If the writer were to delete the opening sentence of this paragraph (beginning the essay with "Sir Arthur Conan Doyle entertained a variety of fanciful..."), the essay would primarily lose:
A. information that sets up a contrast that follows.
B. an irrelevant but humorous digression.
C. information that explains Doyle's motivations.
D. an important description of the setting.

48. F. NO CHANGE
G. girls' faces.
H. girls faces.
J. girls face's.

49. A. NO CHANGE
B. this seemingly evident but apparent
C. what seemed to be an apparent
D. this apparent

50. F. NO CHANGE
G. who
H. which
J. they

51. A. NO CHANGE
B. in which the magazine where
C. in which
D. being where



Conan Doyle sent a copy of one of the photographs to his friend Harry Houdini, the famous magician and escape artist. Houdini, who devoted considerable effort to exposing hoaxes involving spiritualism and was

52

skeptical about the existence of supernatural beings. 53

When Houdini remained unconvinced by the evidence, Conan Doyle became angry. Though the two

remained cordial, but their friendship was damaged

54

due to the fact that they had the disagreement.

55

Some sixty years later, an elderly Frances Griffiths

56

publicly admitted that her and her cousin had staged the photographs as a practical joke. Shortly after her revelation, computer enhancement revealed the hatpins that were used to prop up the cardboard-cutout fairies.

58

Scientific analysis, since photography was a new art, finally closed the Case of the Trick Photographs.

59

52. F. NO CHANGE
 G. spiritualism, being
 H. spiritualism, was
 J. spiritualism and
53. If the writer were to delete the preceding sentence, the paragraph would primarily lose:
 A. details that provide an explanation for the friendship between Conan Doyle and Houdini.
 B. information that helps set the stage for what happens next in the essay.
 C. a description of the reasons behind Houdini's skepticism about the supernatural.
 D. nothing at all, since this sentence provides irrelevant information.
54. F. NO CHANGE
 G. cordial and
 H. cordial that
 J. cordial,
55. A. NO CHANGE
 B. because of the fact that they had a
 C. due to the fact of their
 D. by the
56. F. NO CHANGE
 G. (Do NOT begin new paragraph) After some
 H. (Begin new paragraph) Since some
 J. (Begin new paragraph) Some
57. A. NO CHANGE
 B. her cousin and herself
 C. she and her cousin
 D. her cousin and her
58. Which of the following alternatives to the underlined portion would NOT be acceptable?
 F. that had been used
 G. the girls used
 H. using
 J. used
59. Which choice would best tie the conclusion of this essay to its opening sentence?
 A. NO CHANGE
 B. of the kind a modern-day Sherlock Holmes might use,
 C. which the great Houdini himself would have appreciated,
 D. a methodology that was still in its infancy,



Question 60 asks about the preceding passage as a whole.

60. Suppose the writer had decided to write an essay that summarizes how beliefs in the supernatural have influenced the writing of famous authors. Would this essay fulfill the writer's goal?
- F. Yes, because the essay makes the point that Conan Doyle's belief in fairies clearly influenced his Sherlock Holmes stories.
 - G. Yes, because the essay indicates that Conan Doyle's disagreement with Houdini motivated him to write about the supernatural.
 - H. No, because the essay argues that the author's belief in fairies and the supernatural did not in any way affect his writing.
 - J. No, because the essay limits its focus to the particular events surrounding one author's reaction to evidence of the supernatural.

PASSAGE V

Her Letters to the World

Emily Dickinson, one of America's great nineteenth-century poets, was a prolific letter writer. Although her physical contact with the world was limited by caring for her invalid mother and by her own poor health, whose correspondence was

61

extensive: over one thousand letters to upwards of one hundred correspondents. These letters provide insight into her daily life and her poetry.

62

Dickinson's lifetime of letters range from playful to serious. As a young woman she wrote, of pining for a

63

valentine and of visiting the Chinese Museum in Boston. Her letters in later years reveal that she missed friends and

64

61. A. NO CHANGE
B. their
C. Dickinson's
D. who's
62. F. NO CHANGE
G. extensive, and over
H. extensive; over
J. extensive. Over
63. A. NO CHANGE
B. (Do NOT begin new paragraph) As a young woman, she wrote
C. (Begin new paragraph) As a young woman, she wrote,
D. (Begin new paragraph) As a young woman, she wrote
64. F. NO CHANGE
G. visiting to
H. of her visiting to
J. of her visiting at

encouraged them to visit. Dickinson stayed in contact with correspondents for many years. In a teasing letter to her brother, she bemoaned the fact that a big barn fire couldn't have waited until he returned to see it, since he "enjoyed

such things so much." Other letters are solemn; speaking

of relatives and friends whom had died.

Perhaps the correspondent who came to know Dickinson best through their thirty-six-year exchange of letters was Emily's friend, sister-in-law, and neighbor, Susan Gilbert Dickinson. Susan was a spiritual, social, and intellectual companion for Emily. In fact, in one letter, Emily stated that Shakespeare was the only person who had taught her more than Susan had.

One significant aspect of this relationship was: that Susan was perhaps the only reader of Emily's poems-in-progress. Letters between the two suggest that Susan might frequently have given feedback on her work, including some of her most famous

poems, composed at her home in Amherst, Massachusetts.

At one point, Emily sent a draft of her poem "Safe in Their

Alabaster Chambers" to Susan, who read the poem. As

65. Given that all of the choices are true, which one best develops the paragraph's focus on the roles that letters played in Emily Dickinson's life?

- A. NO CHANGE
- B. Her personal interests also included keen observation of the natural world around her.
- C. Though she produced volumes of letters, none were shared publicly until after her death.
- D. She enjoyed hearing their news and reflecting with them on political events.

66. F. NO CHANGE
G. solemn they speak
H. solemn, speaking
J. solemn. Speaking

67. A. NO CHANGE
B. who
C. who they
D. of whom

68. F. NO CHANGE
G. was that Susan
H. was, that Susan
J. was that Susan,

69. A. NO CHANGE
B. her feedback on Emily's
C. Emily feedback on her
D. her feedback on her

70. F. NO CHANGE
G. poems, which varied in form, style, and line length.
H. poems, most without obvious rhyme.
J. poems.

71. Given that all the choices are true, which one would most clearly describe an interaction between Susan and Emily during Emily's writing process?

- A. NO CHANGE
- B. liked the poem tremendously.
- C. considered and thought about the poem.
- D. praised the poem but suggested revisions.



a result, Emily wrote two other versions of the second stanza.

72

Dickinson's last twenty years of letters—many over 1,500 words in length—reveals the breadth and depth of

73

one's connection to the world through a wide circle of

74

correspondents. Perhaps, this legacy of letters, explains what she meant when she said that her friends were her “estate.”

75

72. F. NO CHANGE
 G. rewrote two other alternate
 H. rewrote two additional alternate
 J. wrote two alternate revised

73. A. NO CHANGE
 B. reveal
 C. will of revealed
 D. would of revealed

74. F. NO CHANGE
 G. people's
 H. her
 J. their

75. A. NO CHANGE
 B. Perhaps this, legacy of letters,
 C. Perhaps this legacy of letters,
 D. Perhaps this legacy of letters

END OF TEST 1

STOP! DO NOT TURN THE PAGE UNTIL TOLD TO DO SO.



MATHEMATICS TEST

60 Minutes—60 Questions

DIRECTIONS: Solve each problem, choose the correct answer, and then fill in the corresponding oval on your answer document.

Do not linger over problems that take too much time. Solve as many as you can; then return to the others in the time you have left for this test.

You are permitted to use a calculator on this test. You may use your calculator for any problems you choose,

but some of the problems may best be done without using a calculator.

Note: Unless otherwise stated, all of the following should be assumed.

1. Illustrative figures are NOT necessarily drawn to scale.
2. Geometric figures lie in a plane.
3. The word *line* indicates a straight line.
4. The word *average* indicates arithmetic mean.

1. Two enterprising college students decide to start a business. They will make up and deliver helium balloon bouquets for special occasions. It will cost them \$39.99 to buy a machine to fill the balloons with helium. They estimate that it will cost them \$2.00 to buy the balloons, helium, and ribbons needed to make each balloon bouquet. Which of the following expressions could be used to model the total cost for producing b balloon bouquets?
 - A. $\$ 2.00b + \39.99
 - B. $\$37.99b$
 - C. $\$39.99b + \$ 2.00$
 - D. $\$41.99b$
 - E. $\$79.98b$
2. What is the value of the expression $(x - y)^2$ when $x = 5$ and $y = -1$?
 - F. 4
 - G. 6
 - H. 16
 - J. 24
 - K. 36
3. On the first day of school, Mr. Vilani gave his third-grade students 5 new words to spell. On each day of school after that, he gave the students 3 new words to spell. In the first 20 days of school, how many new words had he given the students to spell?
 - A. 28
 - B. 62
 - C. 65
 - D. 68
 - E. 152
4. Which of the following is equivalent to $(4x^2)^3$?
 - F. $64x^8$
 - G. $64x^6$
 - H. $12x^6$
 - J. $12x^5$
 - K. $4x^6$
5. Which of the following lists all the positive factors of 8?
 - A. 1, 8
 - B. 2, 4
 - C. 2, 4, 6
 - D. 8, 16, 32
 - E. 1, 2, 4, 8
6. Which of the following is an equivalent simplified expression for $2(4x + 7) - 3(2x - 4)$?
 - F. $x + 2$
 - G. $2x + 2$
 - H. $2x + 26$
 - J. $3x + 10$
 - K. $3x + 11$
7. To determine a student's overall test score for the semester, Ms. Lopez throws out the lowest test score and takes the average of the remaining test scores. Victor earned the following test scores in Ms. Lopez's class this semester: 62, 78, 83, 84, and 93. What overall test score did Victor earn in Ms. Lopez's class this semester?
 - A. 67.6
 - B. 80.0
 - C. 83.0
 - D. 83.5
 - E. 84.5
8. Uptown Cable, a cable TV provider, charges each customer \$120 for installation, plus \$25 per month for cable programming. Uptown's competitor, Downtown Cable, charges each customer \$60 for installation, plus \$35 per month for cable programming. A customer who signs up with Uptown will pay the same total amount for cable TV as a customer who signs up with Downtown if each pays for installation and cable programming for how many months?
 - F. 3
 - G. 6
 - H. 10
 - J. 18
 - K. 30



9. In the 8-sided figure below, adjacent sides meet at right angles and the lengths given are in meters. What is the perimeter of the figure, in meters?

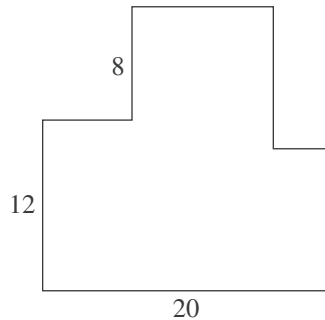

- A. 40
B. 80
C. 120
D. 160
E. 400
10. The sum of the real numbers x and y is 11. Their difference is 5. What is the value of xy ?

- F. 3
G. 5
H. 8
J. 24
K. 55

11. For all x , $(3x + 7)^2 = ?$

- A. $6x + 14$
B. $6x^2 + 14$
C. $9x^2 + 49$
D. $9x^2 + 21x + 49$
E. $9x^2 + 42x + 49$

12. What is the slope of the line through $(-5, 2)$ and $(6, 7)$ in the standard (x, y) coordinate plane?

- F. 9
G. 5
H. -5
J. $\frac{5}{11}$
K. $-\frac{5}{11}$

13. When $\frac{1}{3}k + \frac{1}{4}k = 1$, what is the value of k ?

- A. $\frac{1}{7}$
B. $\frac{12}{7}$
C. $\frac{7}{2}$
D. 6
E. 12

14. What is the length, in feet, of the hypotenuse of a right triangle with legs that are 6 feet long and 7 feet long, respectively?

- F. $\sqrt{13}$
G. $\sqrt{85}$
H. 13
J. 21
K. 42

15. Hexagon $ABCDEF$ shown below was drawn on a grid with unit squares. Each vertex is at the intersection of 2 grid lines. What is the area of the hexagon, in square units?

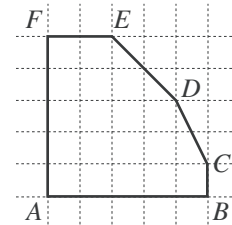

- A. 18
B. 19
C. 20
D. 22
E. 25

16. In the figure below, \overline{AD} is perpendicular to \overline{BD} , \overline{AC} is perpendicular to \overline{BC} , and $AD \cong BC$. Which of the following congruences is NOT necessarily true?

- F. $\overline{AC} \cong \overline{BD}$
G. $\overline{AD} \cong \overline{AE}$
H. $\overline{AE} \cong \overline{BE}$
J. $\angle DAB \cong \angle CBA$
K. $\angle EAB \cong \angle EBA$

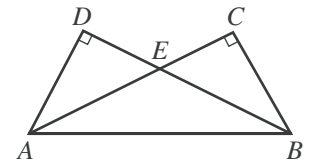

17. Leticia went into Discount Music to price CDs. All CDs were discounted 23% off the marked price. Leticia wanted to program her calculator so she could input the marked price and the discounted price would be the output. Which of the following is an expression for the discounted price on a marked price of p dollars?

- A. $p - 0.23p$
B. $p - 0.23$
C. $p - 23p$
D. $p - 23$
E. $0.23p$

18. In the figure below, A , D , B , and G are collinear. If $\angle CAD$ measures 76° , $\angle BCD$ measures 47° , and $\angle CBG$ measures 140° , what is the degree measure of $\angle ACD$?

- F. 12°
G. 14°
H. 17°
J. 36°
K. 43°

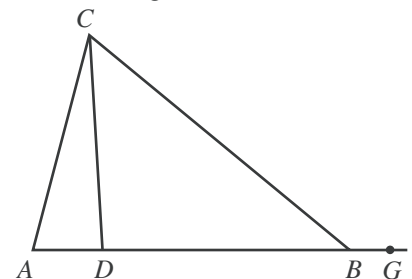



19. Ms. Lewis plans to drive 900 miles to her vacation destination, driving an average of 50 miles per hour. How many miles per hour faster must she average, while driving, to reduce her total driving time by 3 hours?

A. 5
B. 8
C. 10
D. 15
E. 18

20. For all positive integers x , what is the greatest common factor of the 2 numbers $216x$ and $180x$?

F. 6
G. 72
H. x
J. $12x$
K. $36x$

21. The table below shows the price of different quantities of standard-sized lemons at Joe's Fruit Stand. What is the least amount of money needed to purchase exactly 20 standard-sized lemons if the bags must be sold intact and there is no tax charged for lemons?

Number of lemons:	1	bag of 6	bag of 12
Total price:	\$0.30	\$1.20	\$2.10

A. \$3.60
B. \$3.90
C. \$4.20
D. \$4.50
E. \$6.00

22. The diameter, d centimeters, of the metal poles Goodpole Manufacturing produces must satisfy the inequality $|d - 3| \leq 0.001$. What is the maximum diameter, in centimeters, such a metal pole may have?

F. 1.4995
G. 1.5005
H. 2.999
J. 3.000
K. 3.001

23. Which of the following is a factored form of the expression $5x^2 - 13x - 6$?

A. $(x - 3)(5x + 2)$
B. $(x - 2)(5x - 3)$
C. $(x - 2)(5x + 3)$
D. $(x + 2)(5x - 3)$
E. $(x + 3)(5x - 2)$

24. A bag contains 6 red marbles, 5 yellow marbles, and 7 green marbles. How many additional red marbles must be added to the 18 marbles already in the bag so that the probability of randomly drawing a red marble is $\frac{3}{5}$?

F. 12
G. 16
H. 18
J. 24
K. 36

25. Which of the following trigonometric equations is valid for the side measurement x inches, diagonal measurement y inches, and angle measurement w° in the rectangle shown below?

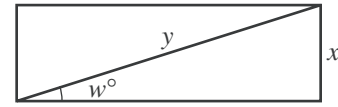

A. $\cos w^\circ = \frac{x}{y}$
B. $\cot w^\circ = \frac{x}{y}$
C. $\sec w^\circ = \frac{x}{y}$
D. $\sin w^\circ = \frac{x}{y}$
E. $\tan w^\circ = \frac{x}{y}$

26. The slope of the line with equation $y = ax + b$ is greater than the slope of the line with equation $y = cx + b$. Which of the following statements *must* be true about the relationship between a and c ?

F. $a \leq c$
G. $a < c$
H. $a = c$
J. $a > c$
K. $a \geq c + 1$

27. Minh cuts a board in the shape of a regular hexagon and pounds in a nail at an equal distance from each vertex, as shown in the figure below. How many rubber bands will she need in order to stretch a different rubber band across every possible pair of nails?

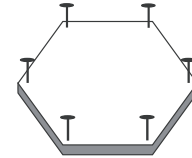

A. 15
B. 14
C. 12
D. 9
E. 6

28. There are 280 runners registered for a race, and the runners are divided into 4 age categories, as shown in the table below.

Age category:	under 16	16–25	26–35	over 35
Number of runners:	40	76	112	52

The prize committee has 60 prizes to award and wants the prizes to be awarded in proportion to the number of runners registered in each category. How many prizes should be designated for the 26–35 age category?

F. 15
G. 17
H. 24
J. 36
K. 40

GO ON TO THE NEXT PAGE.



Use the following information to answer questions 29–32.

The youth center has installed a swimming pool on level ground. The pool is a right circular cylinder with a diameter of 24 feet and a height of 6 feet. A diagram of the pool and its entry ladder is shown below.

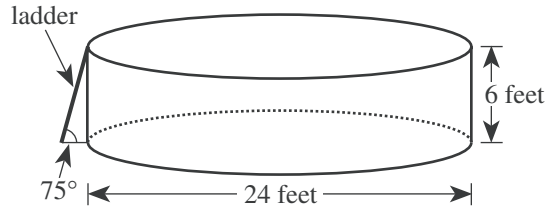

29. To the nearest cubic foot, what is the volume of water that will be in the pool when it is filled with water to a depth of 5 feet?

(Note: The volume of a cylinder is given by $\pi r^2 h$, where r is the radius and h is the height.)

- A. 942
- B. 1,885
- C. 2,262
- D. 9,047
- E. 11,310

30. A plastic cover is made for the pool. The cover will rest on the top of the pool and will include a wedge-shaped flap that forms a 45° angle at the center of the cover, as shown in the figure below. A zipper will go along 1 side of the wedge-shaped flap and around the arc. Which of the following is closest to the length, in feet, of the zipper?

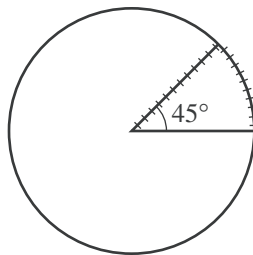

- F. 17
- G. 22
- H. 24
- J. 29
- K. 57

31. Two hoses are used to fill the pool. Twice as many gallons of water per minute flow through one of the hoses as through the other. Both hoses had been on for 12 hours and had filled the pool to the 4-foot mark when the hose with the faster flow stopped working. The hose with the slower flow then finished filling the pool to the 5-foot mark. Which of the following graphs shows the relationship between the time spent filling the pool and the height of the water in the pool?

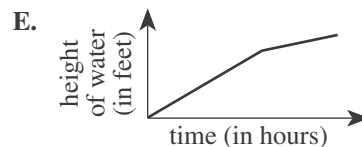
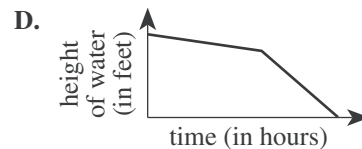
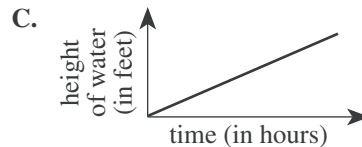
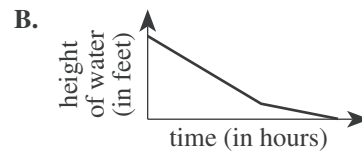
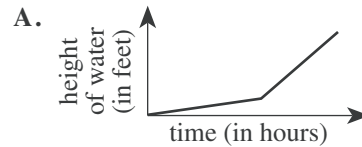

32. The directions for assembling the pool state that the ladder should be placed at an angle of 75° relative to level ground. Which of the following expressions involving tangent gives the distance, in feet, that the bottom of the ladder should be placed away from the bottom edge of the pool in order to comply with the directions?

F. $\frac{6}{\tan 75^\circ}$

G. $\frac{\tan 75^\circ}{6}$

H. $\frac{1}{6 \tan 75^\circ}$

J. $6 \tan 75^\circ$

K. $\tan(6 \cdot 75^\circ)$

GO ON TO THE NEXT PAGE.

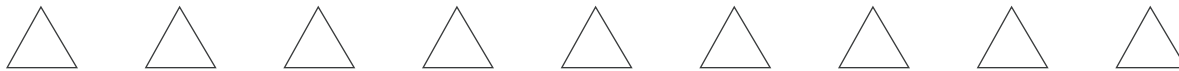

33. For a population that grows at a constant rate of $r\%$ per year, the formula $P(t) = p_0\left(1 + \frac{r}{100}\right)^t$ models the population t years after an initial population of p_0 people is counted.

The population of the city of San Jose was 782,000 in 1990. Assume the population grows at a constant rate of 5% per year. According to this formula, which of the following is an expression for the population of San Jose in the year 2000?

- A. $782,000(6)^{10}$
 B. $782,000(1.5)^{10}$
 C. $782,000(1.05)^{10}$
 D. $(782,000 \times 1.5)^{10}$
 E. $(782,000 \times 1.05)^{10}$
34. Tom's long-distance service charges \$0.10 per minute from 7:00 P.M. to 7:00 A.M. on weekdays, all day on Saturdays, and all day on holidays; \$0.05 per minute all day on Sundays; and \$0.25 per minute at all other times. The table below gives his long-distance calls for 1 week, including the date and day of each call, the time it was placed, and the number of minutes it lasted.

Date and day	Time	Number of minutes
11/22 Tuesday	5:00 P.M.	8
11/23 Wednesday	10:30 A.M.	10
11/24 Thursday Thanksgiving holiday	11:30 A.M.	15
11/26 Saturday	9:30 A.M.	17
11/27 Sunday	12:15 P.M.	22

What did Tom's long-distance service charge him for the calls in the table?

- F. \$7.30
 G. \$7.60
 H. \$7.95
 J. \$8.80
 K. \$9.90
35. The parallel sides of the isosceles trapezoid shown below are 10 feet long and 16 feet long, respectively. What is the distance, in feet, between these 2 sides?

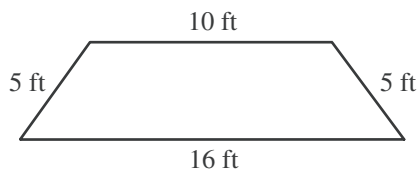

- A. 3
 B. 4
 C. 5
 D. 10
 E. 16

36. The inequality $3(x + 2) > 4(x - 3)$ is equivalent to which of the following inequalities?

- F. $x < -6$
 G. $x < 5$
 H. $x < 9$
 J. $x < 14$
 K. $x < 18$

37. In the standard (x,y) coordinate plane, the midpoint of \overline{AB} is $(4,-3)$ and A is located at $(1,-5)$. If (x,y) are the coordinates of B , what is the value of $x + y$?

- A. 19
 B. 8
 C. 6
 D. -1.5
 E. -3

38. For all x in the domain of the function $\frac{x+1}{x^3-x}$, this function is equivalent to:

- F. $\frac{1}{x^2} - \frac{1}{x^3}$
 G. $\frac{1}{x^3} - \frac{1}{x}$
 H. $\frac{1}{x^2-1}$
 J. $\frac{1}{x^2-x}$
 K. $\frac{1}{x^3}$

39. In the figure below, line l is parallel to line m . Transversals t and u intersect at point A on l and intersect m at points C and B , respectively. Point X is on m , the measure of $\angle ACX$ is 130° , and the measure of $\angle BAC$ is 80° . How many of the angles formed by rays of l , m , t , and u have measure 50° ?

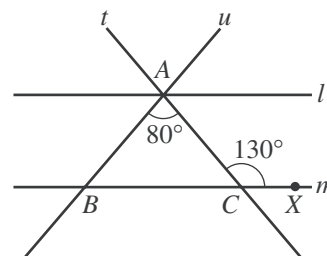

- A. 4
 B. 6
 C. 8
 D. 10
 E. 12



40. Tickets for the Senior Talent Show at George Washington Carver High School are \$3 for adults and \$2 for students. To cover expenses, a total of \$600 must be collected from ticket sales for the show. One of the following graphs in the standard (x,y) coordinate plane, where x is the number of adult tickets sold and y is the number of student tickets sold, represents all the possible combinations of ticket sales that cover at least \$600 in expenses. Which graph is it?

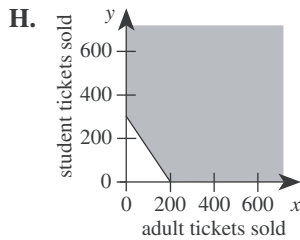
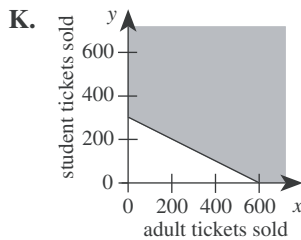
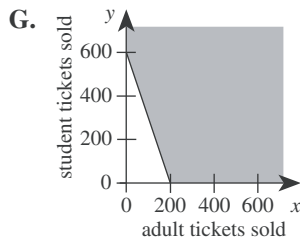
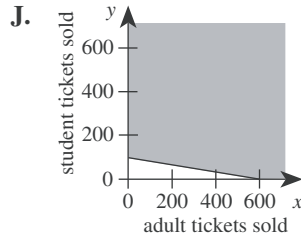
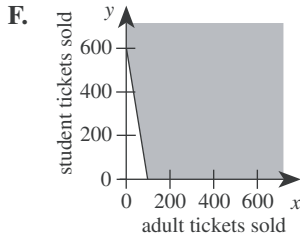

41. What is the median of the following 7 scores?

42, 67, 33, 79, 33, 89, 21

- A. 42
- B. 52
- C. 54.5
- D. 56
- E. 79

42. What are the real solutions to the equation $|x|^2 + 2|x| - 3 = 0$?

- F. ± 1
- G. ± 3
- H. 1 and 3
- J. -1 and -3
- K. ± 1 and ± 3

43. The point $(2,5)$ is shown in the standard (x,y) coordinate plane below. Which of the following is another point on the line through the point $(2,5)$ with a slope of $-\frac{2}{3}$?

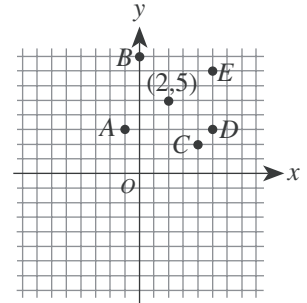

- A. $A(-1,3)$
- B. $B(0,8)$
- C. $C(4,2)$
- D. $D(5,3)$
- E. $E(5,7)$

44. For the triangles in the figure below, which of the following ratios of side lengths is equivalent to the ratio of the perimeter of $\triangle ABC$ to the perimeter of $\triangle DAB$?

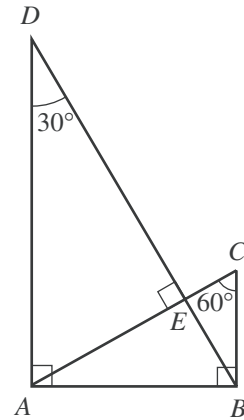

- F. $AB:AD$
- G. $AB:BD$
- H. $AD:BD$
- J. $BC:AD$
- K. $BC:BD$

45. In the figure below, 2 nonadjacent sides of a regular pentagon (5 congruent sides and 5 congruent interior angles) are extended until they meet at point X . What is the measure of $\angle X$?

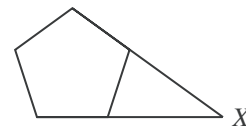

- A. 18°
- B. 30°
- C. 36°
- D. 45°
- E. 72°

46. The edges of a cube are each 3 inches long. What is the surface area, in square inches, of this cube?

- F. 9
- G. 18
- H. 27
- J. 36
- K. 54



47. A number is increased by 25% and the resulting number is then decreased by 20%. The final number is what percent of the original number?
- A. 90%
B. 95%
C. 100%
D. 105%
E. 120%
48. Two numbers are *reciprocals* if their product is equal to 1. If x and y are reciprocals and $x > 1$, then y must be:
- F. less than -1 .
G. between 0 and -1 .
H. equal to 0.
J. between 0 and 1.
K. greater than 1.

49. The number line graph below is the graph of which of the following inequalities?



- A. $-1 \leq x$ and $3 \leq x$
B. $-1 \leq x$ and $3 \geq x$
C. $-1 \leq x$ or $3 \leq x$
D. $-1 \geq x$ or $3 \leq x$
E. $-1 \geq x$ or $3 \geq x$
50. All of the following graphs have equal scales on the axes. One of the graphs shows only points for which the y -coordinate is 1 less than the square of the x -coordinate. Which one?

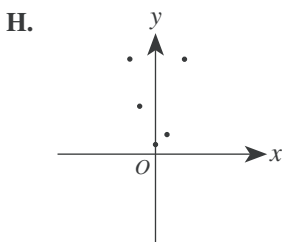
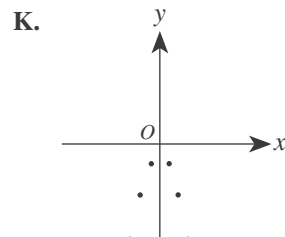
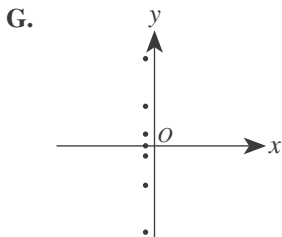
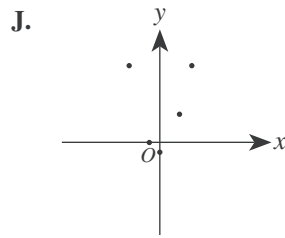
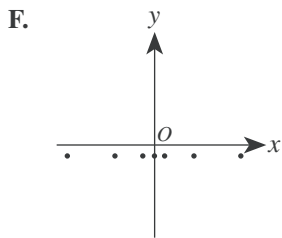

51. In teaching a lesson on the concept of thirds, Ms. Chu uses a divide-and-set-aside procedure. She starts with a certain number of colored disks, divides them into 3 equal groups, and sets 1 group aside to illustrate $\frac{1}{3}$. She repeats the procedure by taking the disks she had NOT set aside, dividing them into 3 equal groups, and setting 1 of these groups aside. If Ms. Chu wants to be able to complete the divide-and-set-aside procedure at least 4 times (without breaking any of the disks into pieces), which of the following is the minimum number of colored disks she can start with?

- A. 12
B. 15
C. 27
D. 54
E. 81

52. Which of the following is true for all consecutive integers m and n such that $m < n$?

- F. m is odd
G. n is odd
H. $n - m$ is even
J. $n^2 - m^2$ is odd
K. $m^2 + n^2$ is even

53. A function P is defined as follows:

$$\begin{aligned} \text{for } x > 0, P(x) &= x^5 + x^4 - 36x - 36 \\ \text{for } x < 0, P(x) &= -x^5 + x^4 + 36x - 36 \end{aligned}$$

What is the value of $P(-1)$?

- A. -70
B. -36
C. 0
D. 36
E. 70

54. For a project in Home Economics class, Kirk is making a tablecloth for a circular table 3 feet in diameter. The finished tablecloth needs to hang down 5 inches over the edge of the table all the way around. To finish the edge of the tablecloth, Kirk will fold under and sew down 1 inch of the material all around the edge. Kirk is going to use a single piece of rectangular fabric that is 60 inches wide. What is the shortest length of fabric, in inches, Kirk could use to make the tablecloth without putting any separate pieces of fabric together?

- F. 15
G. 24
H. 30
J. 42
K. 48



55. The equations of the 2 graphs shown below are $y_1(t) = a_1 \sin(b_1 t)$ and $y_2(t) = a_2 \cos(b_2 t)$, where the constants b_1 and b_2 are both positive real numbers.

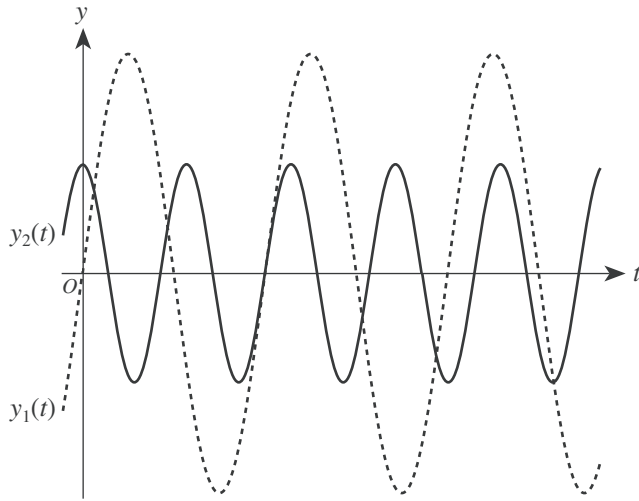

Which of the following statements is true of the constants a_1 and a_2 ?

- A. $0 < a_1 < a_2$
 B. $0 < a_2 < a_1$
 C. $a_1 < 0 < a_2$
 D. $a_1 < a_2 < 0$
 E. $a_2 < a_1 < 0$
56. For x such that $0 < x < \frac{\pi}{2}$, the expression $\frac{\sqrt{1 - \cos^2 x}}{\sin x} + \frac{\sqrt{1 - \sin^2 x}}{\cos x}$ is equivalent to:
- F. 0
 G. 1
 H. 2
 J. $-\tan x$
 K. $\sin 2x$
57. Consider the functions $f(x) = \sqrt{x}$ and $g(x) = 7x + b$. In the standard (x,y) coordinate plane, $y = f(g(x))$ passes through $(4,6)$. What is the value of b ?
- A. 8
 B. -8
 C. -25
 D. -26
 E. $4 - 7\sqrt{6}$

58. The triangle, $\triangle XYZ$, that is shown below has side lengths of x , y , and z inches and is not a right triangle. Let X' be the image of X when the triangle is reflected across \overline{YZ} . Which of the following is an expression for the perimeter, in inches, of quadrilateral $X'YXZ$?

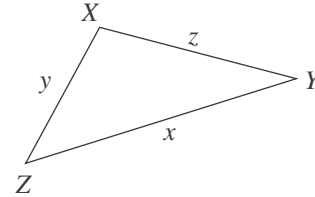

- F. $2(y + z) + x$
 G. $2(x + y + z)$
 H. $2(x + y)$
 J. $2(x + z)$
 K. $2(y + z)$
59. A function f is an *odd* function if and only if $f(-x) = -f(x)$ for every value of x in the domain of f . One of the functions graphed in the standard (x,y) coordinate plane below is an odd function. Which one?

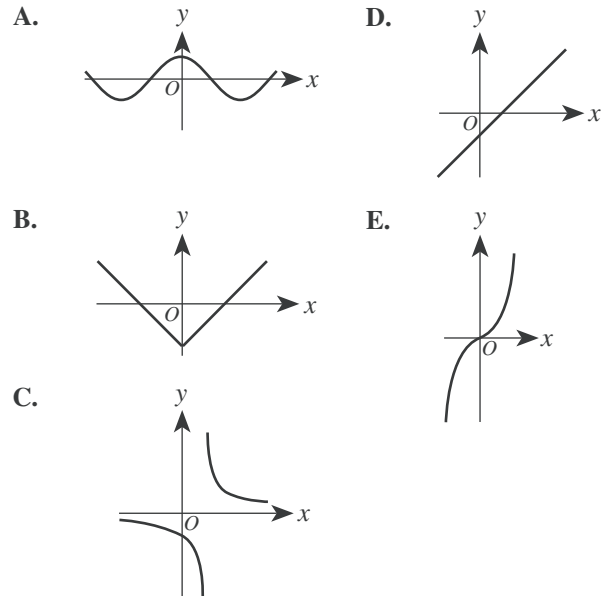

60. What is the real value of x in the equation $\log_2 24 - \log_2 3 = \log_5 x$?
- F. 3
 G. 21
 H. 72
 J. 125
 K. 243

END OF TEST 2

STOP! DO NOT TURN THE PAGE UNTIL TOLD TO DO SO.

DO NOT RETURN TO THE PREVIOUS TEST.

READING TEST

35 Minutes—40 Questions

DIRECTIONS: There are four passages in this test. Each passage is followed by several questions. After reading a passage, choose the best answer to each question and fill in the corresponding oval on your answer document. You may refer to the passages as often as necessary.

Passage I

PROSE FICTION: This passage is adapted from the short story “American History” by Judith Ortiz-Cofer (©1992 by Judith Ortiz-Cofer). The story appeared in the anthology *Iguana Dreams: New Latino Fiction*.

There was only one source of beauty and light for me my ninth grade year. The only thing I had anticipated at the start of the semester. That was seeing Eugene. In August, Eugene and his family had moved
5 into the only house on the block that had a yard and trees. I could see his place from my bedroom window in El Building. In fact, if I sat on the fire escape I was literally suspended above Eugene’s backyard. It was my favorite spot to read my library books in the summer.
10 Until that August the house had been occupied by an old couple. Over the years I had become part of their family, without their knowing it, of course. I had a view of their kitchen and their backyard, and though I could not hear what they said, I knew when they were arguing,
15 when one of them was sick, and many other things. I knew all this by watching them at mealtimes. I could see their kitchen table, the sink, and the stove. During good times, he sat at the table and read his newspapers while she fixed the meals. If they argued, he would leave and
20 the old woman would sit and stare at nothing for a long time. When one of them was sick, the other would come and get things from the kitchen and carry them out on a tray. The old man had died in June. The house had stood empty for weeks. I had had to resist the temptation to
25 climb down into the yard and water the flowers the old lady had taken such good care of.

By the time Eugene’s family moved in, the yard was a tangled mass of weeds. The father had spent several days mowing, and when he finished, from where I sat, I didn’t see the red, yellow, and purple clusters that meant flowers to me. I didn’t see this family sit down at the kitchen table together. It was just the mother, a red-headed tall woman who wore a white uniform; the father was gone before I got up in the morning and was
35 never there at dinner time. I only saw him on weekends when they sometimes sat on lawn-chairs under the oak tree, each hidden behind a section of the newspaper; and there was Eugene. He was tall and blond, and he wore glasses. I liked him right away because he sat at the kitchen table and read books for hours. That
40 summer, before we had even spoken one word to each other, I kept him company on my fire escape.

Once school started I looked for him in all my classes, but P. S. 13 was a huge place and it took me
45 days and many discreet questions to discover Eugene. After much maneuvering I managed “to run into him” in the hallway where his locker was—on the other side of the building from mine—and in study hall at the library where he first seemed to notice me, but did not
50 speak; and finally, on the way home after school one day when I decided to approach him directly, though my stomach was doing somersaults.

I was ready for rejection, snobbery, the worst. But when I came up to him and blurted out: “You’re
55 Eugene. Right?” he smiled, pushed his glasses up on his nose, and nodded. I saw then that he was blushing deeply. Eugene liked me, but he was shy. I did most of the talking that day. He nodded and smiled a lot. In the weeks that followed, we walked home together. He
60 would linger at the corner of El Building for a few minutes then walk down to his house.

I did not tell Eugene that I could see inside his kitchen from my bedroom. I felt dishonest, but I liked my secret sharing of his evenings, especially now that I
65 knew what he was reading since we chose our books together at the school library.

I also knew my mother was unhappy in Paterson, New Jersey, but my father had a good job at the blue-jeans factory in Passaic and soon, he kept assuring us,
70 we would be moving to our own house there. I had learned to listen to my parents’ dreams, which were spoken in Spanish, as fairy tales, like the stories about life in Puerto Rico before I was born. I had been to the island once as a little girl. We had not been back there
75 since then, though my parents talked constantly about buying a house on the beach someday, retiring on the island—that was a common topic among the residents of El Building. As for me, I was going to go to college and become a teacher.

But after meeting Eugene I began to think of the present more than of the future. What I wanted now was to enter that house I had watched for so many years. I wanted to see the other rooms where the old people had lived, and where the boy spent his time. Most of all, I
85 wanted to sit at the kitchen table with Eugene like two adults, like the old man and his wife had done, maybe drink some coffee and talk about books.

GO ON TO THE NEXT PAGE.

1. The main theme of this passage concerns the:
 - A. difficulty of first starting and then maintaining a friendship.
 - B. process of making a new friend and how the friendship changes the narrator.
 - C. problems the narrator has dealing with the loss of her former neighbors.
 - D. differences in the lives led by two pairs of adults who at different times lived in the same house.
2. Which of the following questions is NOT answered by information in the passage?
 - F. Has the narrator ever walked around inside Eugene's house?
 - G. What hobby or interest do Eugene and the narrator share?
 - H. What makes Eugene's house different from other houses on the block?
 - J. What careers other than teaching has the narrator considered pursuing?
3. The narrator draws which of the following comparisons between the old couple and Eugene's parents?
 - A. The old couple were more socially outgoing and had many more friends than Eugene's parents.
 - B. Eugene's parents are just as interested in tending the lawn and flowers as the old couple were.
 - C. Eugene's parents are less nurturing of each other and spend less time together than the old couple did.
 - D. Just like the old man and old woman, both of Eugene's parents appear to have jobs outside the home.
4. In terms of developing the narrative, the last two paragraphs (lines 67–87) primarily serve to:
 - F. provide background details about the narrator and her family in order to highlight the narrator's unique and shifting perspective.
 - G. describe the narrator's family in order to establish a contrast between her parents and Eugene's parents.
 - H. portray the narrator's family in order to show how her friendship with Eugene affected the various members of her family.
 - J. depict the hopes and dreams of the narrator's parents in order to show how her parents' aspirations changed over time.
5. It can most reasonably be inferred from the passage that when the narrator says, "I didn't see the red, yellow, and purple clusters that meant flowers to me" (lines 30–31), she is most nearly indicating that:
 - A. from her current position, she couldn't see the old woman's flowers, which were still growing near the house.
 - B. the flowers grown by the old woman had died because the narrator had stopped watering them.
 - C. the flowers grown by the old woman had been cut down when Eugene's father mowed the lawn.
 - D. the weeds that had grown up in the old couple's lawn had intertwined with the flowers, making the flowers hard to see.
6. According to the narrator, which of the following statements was true about Eugene at the moment when she first talked to him?
 - F. Due to the size of the school, he had not even noticed the narrator until she started talking to him.
 - G. He had searched unsuccessfully for the narrator's locker several different times and had been too shy to ask someone where it was.
 - H. He had first noticed the narrator in study hall but had been uninterested in her until she introduced herself.
 - J. He had apparently taken notice of the narrator at school and had come to like her but felt nervous about introducing himself.
7. When the narrator says, "I began to think of the present more than of the future" (lines 80–81), she most likely means that meeting Eugene led her to:
 - A. shift some of her attention away from her career plans and onto the developing friendship.
 - B. think more about her own work interests than about the career her parents thought she should pursue.
 - C. put off her plans of returning to Puerto Rico for a visit in favor of continuing to prepare for college.
 - D. want to spend more time with him instead of helping her parents plan a vacation to Puerto Rico.
8. The narrator most nearly portrays her parents' dreams as:
 - F. close to being realized because of her father's good job.
 - G. somewhat uncommon among the other residents of the family's building.
 - H. ones she has heard about many times but that seem far off and remote to her.
 - J. ones she shares with her parents and longs to fulfill.
9. The narrator claims that she felt close to the old couple because she had:
 - A. listened in on so many of their conversations over the years.
 - B. helped take care of the old woman's flowers after the woman's husband had died.
 - C. been able to watch them as they moved through their entire house.
 - D. regularly observed them during their mealtimes.
10. Which of the following best describes the narrator's feelings about secretly observing Eugene at his home?
 - F. Joy tinged with suspicion
 - G. Enjoyment mixed with guilt
 - H. Happiness overwhelmed by a sense of betrayal
 - J. Pleasure lessened by having actually met him

Passage II

SOCIAL SCIENCE: This passage is adapted from volume 2 of Blanche Wiesen Cook's biography *Eleanor Roosevelt* (©1999 by Blanche Wiesen Cook).

Eleanor Roosevelt [ER] is the most controversial First Lady in United States history. Her journey to greatness, her voyage out beyond the confines of good wife and devoted mother, involved determination and
5 amazing courage. It also involved one of history's most unique partnerships. Franklin Delano Roosevelt [FDR] admired his wife, appreciated her strengths, and depended on her integrity.

However, ER and FDR had different priorities,
10 occasionally competing goals, and often disagreed. In the White House they ran two distinct and separate courts.

By 1933 [her first year as First Lady], ER was an accomplished woman who had achieved several of her
15 life's goals. With her partners, ER was a businesswoman who co-owned the Val-Kill crafts factory, a political leader who edited and copublished the *Women's Democratic News*, and an educator who co-owned and taught at a New York school for girls.

As First Lady, Eleanor Roosevelt did things that
20 had never been done before. She upset race traditions, championed a New Deal for women, and on certain issues actually ran a parallel administration. On housing and the creation of model communities, for
25 example, ER made decisions and engineered policy.

At the center of a network of influential women who ran the Women's Committee of the Democratic Party led by Molly Dewson, ER worked closely with
30 the women who had dominated the nation's social reform struggles for decades. With FDR's election, the goals of the great progressive pioneers, Jane Addams, Florence Kelley, and Lillian Wald, were at last at the forefront of the country's agenda. ER's mentors since
35 1903, they had battled on the margins of national politics since the 1880s for public health, universal education, community centers, sanitation programs, and government responsibility for the welfare of the nation's poor and neglected people.

Now their views were brought directly into the
40 White House. ER lobbied for them personally with her new administrative allies, in countless auditoriums, as a radio broadcaster, and in monthly, weekly, and, by 1936, daily columns. Called "Eleanor Everywhere," she was interested in everyone.

Every life was sacred and worthy, to be improved
45 by education, employment, health care, and affordable housing. Her goal was simple, a life of dignity and decency for all. She was uninterested in complex theories, and demanded action for betterment. She feared
50 violent revolution, but was not afraid of socialism—and she courted radicals.

As fascism and communism triumphed in Europe and Asia, ER and FDR were certain that there was a middle way, what ER called an American "revolution
55 without bloodshed." Her abiding conviction, however, was that nothing good would happen to promote the people's interest unless the people themselves organized to demand government responses. A people's movement required active citizen participation, and
60 ER's self-appointed task was to agitate and inspire community action, encourage united democratic movements for change.

Between 1933 and 1938, while the Depression raged and the New Deal unfolded, ER worked with the
65 popular front. She called for alliances of activists to fight poverty and racism at home, and to oppose isolationism internationally.

Active with the women's peace movement, ER spoke regularly at meetings of the Women's International League for Peace and Freedom, and the Conference on the Cause and Cure of War. She departed,
70 however, from pacifist and isolationist positions and encouraged military preparedness, collective security, and ever-widening alliances.

Between 1933 and 1938 ER published countless
75 articles and six books. She wrote in part for herself, to clear her mind and focus her thoughts. But she also wrote to disagree with her husband. From that time to this, no other First Lady has actually rushed for her pen
80 to jab her husband's public decisions. But ER did so routinely, including in her 1938 essay *This Troubled World*, which was a point-by-point rejection of FDR's major international decisions.

To contemplate ER's life of example and responsibility is to forestall gloom. She understood, above all,
85 that politics is not an isolated individualist adventure. She sought alliances, created community, worked with movements for justice and peace. Against great odds, and under terrific pressure, she refused to withdraw
90 from controversy. She brought her network of agitators and activists into the White House, and never considered a political setback a permanent defeat. She enjoyed the game, and weathered the abuse.

11. As she is revealed in the passage, ER is best described as:
- A. socially controversial but quietly cooperative.
 - B. politically courageous and socially concerned.
 - C. morally strong and deeply traditional.
 - D. personally driven but calmly moderate.

12. The author presents ER's accomplishments as exceptional because ER:
- F. brought politically unpopular views to the forefront of the nation's politics.
 - G. was the first public figure to introduce political roles for women.
 - H. was a political pioneer struggling alone for social reform.
 - J. replaced community action with more powerful White House networks.
13. According to the passage, ER believed that social reform should include all of the following EXCEPT:
- A. promoting community action.
 - B. developing universal education.
 - C. supporting affordable housing.
 - D. establishing involved theories.
14. Based on the passage, ER's approach to social reform can best be characterized as:
- F. passionate and theoretical.
 - G. patient and flexible.
 - H. simplistic and isolationist.
 - J. progressive and determined.
15. It can reasonably be inferred from the passage that at the time ER began working for social reform, the United States was:
- A. deeply committed to reforms in education and health care.
 - B. experiencing a time of national prosperity that contributed to ER's ideals concerning the public welfare.
 - C. concentrating on affairs at home due to isolationist policies and the spread of democracy overseas.
 - D. unsupportive of the idea that the government was responsible for the welfare of its poor and neglected.
16. According to the last paragraph, which of the following statements would the author most likely make with regard to ER's vision and ideals?
- F. ER considered politics a game and played only when she knew she could win.
 - G. ER worked with agitators and remained dedicated to the pursuit of justice and peace in victory and defeat.
 - H. ER placed herself in the position of president, making decisions that determined White House policy.
 - J. ER saw herself as the country's role model and personally responsible for bringing about change.
17. In terms of the passage as a whole, one of the main functions of the third paragraph (lines 13–19) is to suggest that:
- A. ER's successes in various professional pursuits helped prepare her to take action in the political world.
 - B. ER had avoided the political spotlight in her personal pursuits.
 - C. ER had competing and conflicting interests during her first year as first lady.
 - D. while ER had many personal accomplishments, little could have prepared her for life as the first lady.
18. According to the passage, the primary principle underlying ER's goals was that:
- F. every person deserved a dignified and decent life.
 - G. as first lady, she could talk about things that had never been discussed before.
 - H. through radio and columns, she could show she was interested in every person.
 - J. she must lead a bloodless American revolution.
19. The passage states that ER believed the relationship between a people and their government should be:
- A. begun and carried out as if it were an isolated, individualist adventure.
 - B. formed and modeled by the White House.
 - C. based on organized, widespread citizen participation.
 - D. controlled through radio broadcasts and formal channels.
20. In the context of the passage, the author's statement that ER "enjoyed the game, and weathered the abuse" (line 93) most nearly means that ER:
- F. enjoyed her individualist adventure in politics even if criticized.
 - G. preferred to be a team player rather than take the lead.
 - H. embraced the political life and accepted criticism as part of her work.
 - J. understood political games and so did not take politics or criticism very seriously.

Passage III

HUMANITIES: This passage is adapted from the essay “The Interior Life” by Annie Dillard, which appeared in her book *An American Childhood* (©1987 by Annie Dillard).

The interior life is often stupid. Its egoism blinds it and deafens it; its imagination spins out ignorant tales, fascinated. It fancies that the western wind blows on the Self, and leaves fall at the feet of the Self for a reason, and people are watching. A mind risks real ignorance for the sometimes paltry prize of an imagination enriched. The trick of reason is to get the imagination to seize the actual world—if only from time to time.

When I was five, I would not go to bed willingly because something came into my room. My sister Amy, two years old, was asleep in the other bed. What did she know? She was innocent of evil. There was no messiness in her, no roughness for things to cling to, only a charming and charmed innocence that seemed then to protect her, an innocence I needed but couldn’t muster. Since Amy was asleep, furthermore, and since when I needed someone most I was afraid to stir enough to wake her, she was useless.

I lay alone and was almost asleep when the thing entered the room by flattening itself against the open door and sliding in. It was a transparent, luminous oblong. I could see the door whiten at its touch; I could see the blue wall turn pale where it raced over it, and see the maple headboard of Amy’s bed glow. It was a swift spirit; it was an awareness. It made noise. It had two joined parts, a head and a tail. It found the door, wall, and headboard; and it swiped them, charging them with its luminous glance. After its fleet, searching passage, things looked the same, but weren’t.

I dared not blink or breathe. If it found another awareness, it would destroy it.

Every night before it got to me it gave up. It hit my wall’s corner and couldn’t get past. It shrank completely into itself and vanished. I heard the rising roar it made when it died or left. I still couldn’t breathe. I knew that it could return again alive that same night.

Sometimes it came back, sometimes it didn’t. Most often, restless, it came back. The light stripe slipped in the door, ran searching over Amy’s wall, stopped, stretched lunatic at the first corner, raced wailing toward my wall, and vanished into the second corner with a cry. So I wouldn’t go to bed.

It was a passing car whose windshield reflected the corner streetlight outside. I figured it out one night.

Figuring it out was as memorable as the oblong itself. Figuring it out was a long and forced ascent to the very rim of being, to the membrane of skin that both separates and connects the inner life and the outer world. I climbed deliberately from the depths like a diver who releases the monster in his arms and hauls

himself hand over hand up an anchor chain till he meets the ocean’s sparkling membrane and bursts through it; he sights the sunlit, becalmed hull of his boat, which had bulked so ominously from below.

I recognized the noise it made when it left. That is, the noise it made called to mind, at last, my daytime sensations when a car passed—the sight and noise together. A car came roaring down hushed Edgerton Avenue in front of our house, stopped, and passed on shrieking as its engine shifted up the gears. What, precisely, came into the bedroom? A reflection from the car’s oblong windshield. Why did it travel in two parts? The window sash split the light and cast a shadow.

Night after night I labored up the same long chain of reasoning, as night after night the thing burst into the room where I lay awake.

There was a world outside my window and contiguous to it. Why did I have to keep learning this same thing over and over? For I had learned it a summer ago, when men with jackhammers broke up Edgerton Avenue. I had watched them from the yard. When I lay to nap, I listened. One restless afternoon I connected the new noise in my bedroom with the jackhammer men I had been seeing outside. I understood abruptly that these worlds met, the outside and the inside. “Outside,” then, was conceivably just beyond my windows.

The world did not have me in mind. It was a coincidental collection of things and people, of items, and I myself was one such item—a child walking up the sidewalk, whom anyone could see or ignore. The things in the world did not necessarily cause my overwhelming feelings; the feelings were inside me, beneath my skin, behind my ribs, within my skull. They were even, to some extent, under my control.

I could be connected to the outer world by reason, if I chose, or I could yield to what amounted to a narrative fiction, to a show in light projected on the room’s blue walls.

21. Which of the following statements best describes the structure of this passage?

- A. It begins and ends with a series of assertions that surround a story used by the narrator to support and elaborate on those assertions.
- B. It contains a highly detailed anecdote that the narrator uses to show how the claims she makes in the first paragraph are wrong.
- C. It compares and contrasts the narrator’s perspective on an incident in her life with the perspectives of several other people, such as her parents.
- D. It consists mainly of a story about a recent event in the narrator’s life that she feels taught her an interesting but ultimately insignificant lesson.

22. In terms of mood, which of the following best describes lines 9–44?
- F. A steadily increasing feeling of tension
 - G. A consistently high level of tension
 - H. A growing feeling of tension that is finally broken
 - J. A feeling of tension frequently undermined by the narrator’s use of irony and humor
23. The narrator develops the third paragraph (lines 19–29) mainly through:
- A. detached philosophical musings on the nature of the object she sees.
 - B. a detailed description of what she did to try to keep the object out of her room.
 - C. sensory details vividly depicting the object and its movements.
 - D. imaginative speculation on what might be causing the object to appear.
24. The narrator indicates that one reason she did not wake her sister Amy when “something” came into their room was because:
- F. Amy had previously asked the narrator to stop waking her up during the night.
 - G. the narrator knew she could muster her own charmed innocence.
 - H. Amy had already figured out what the thing was before going to sleep.
 - J. the narrator was afraid of alerting the thing to her own presence.
25. It can reasonably be inferred from the passage that the narrator regards her initial discovery of the truth about the object entering her bedroom as:
- A. deflating, because the object turned out to be so ordinary.
 - B. disappointing, because she felt she should have solved the mystery many years ago.
 - C. satisfying, because she could at last ignore the object and go to sleep.
 - D. significant, because solving the mystery led to important insights.
26. It can most reasonably be inferred that for the narrator, the image of the diver bursting through “the ocean’s sparkling membrane” (line 52) symbolizes her:
- F. fear of monsters and of the object in her bedroom.
 - G. crossing of the boundary separating her inner and outer lives.
 - H. struggle to maintain the separation between her inner and outer worlds.
 - J. bitterness at entering reality and leaving behind her comforting memories.
27. As it is used in line 87, the phrase “a show in light” most nearly refers to:
- A. a fictional story the narrator has read.
 - B. a movie the narrator saw at a theater.
 - C. the work of reason in linking a person to the outer world.
 - D. a fantasy created by the mind.
28. The narrator uses the images in lines 3–5 primarily to depict the interior life’s tendency to engage in:
- F. deceptive self-absorption.
 - G. vital self-examination.
 - H. useful analysis of nature.
 - J. fierce debates with itself.
29. Which of the following statements best paraphrases lines 5–8?
- A. The imagination lacks value and should be ignored in favor of paying attention to the actual world.
 - B. Reason can enhance the imagination but at the expense of experience in the actual world.
 - C. Rather than become isolated, the imagination should connect to the actual world at least occasionally.
 - D. Reason, not the imagination, is the best way to appreciate and enrich the actual world.
30. By her statements in lines 77–80, the narrator is most nearly asserting that:
- F. in her world, adults are generally considered more important than children.
 - G. she, like everyone and everything else, was a small part of a larger world.
 - H. it still mattered greatly whether people saw or ignored her.
 - J. she was less valuable than other people in her world.

Passage IV

NATURAL SCIENCE: This passage is adapted from “Publish and Punish: Science’s Snowball Effect” by Jon Van (©1997 by The Chicago Tribune Company).

It’s a scientific finding so fundamental that it certainly will make the history books and maybe snag a Nobel Prize if it pans out, but the notion that cosmic snowballs are constantly pelting Earth is something
5 Louis Frank just as soon would have ducked.

Frank is the University of Iowa physicist whose research led him to declare more than a decade ago that Earth is being bombarded by hundreds of house-sized comets day after day that rain water on our planet and
10 are the reason we have oceans. That weather report caused the widely respected scientist to acquire a certain reputation among his colleagues as a bit unstable, an otherwise estimable fellow whose hard work may have pushed him over the edge.

Frank and his associate, John Sigwarth, probably went a way toward salvaging their reputations when they presented new evidence that leaves little doubt Earth is indeed being bombarded by *something* in a manner consistent with Frank’s small-comet theory.
20 Rather than gloating or anticipating glory, Frank seemed relieved that part of a long ordeal was ending. “I knew we’d be in for it when we first put forth the small-comet theory,” Frank conceded, “but I was naive about just how bad it would be. We were outvoted by
25 about 10,000 to 1 by our colleagues. I thought it would have been more like 1,000 to 1.”

To the non-scientist this may seem a bit strange. After all, the point of science is to discover information and insights about how nature works. Shouldn’t every
30 scientist be eager to overturn existing ideas and replace them with his or her own? In theory, that is the case, but in practice, scientists are almost as loath to embrace radically new ideas as the rest of us.

“Being a scientist puts you into a constant schizophrenic existence,” contends Richard Zare, chairman of the National Science Board. “You have to believe and yet question beliefs at the same time. If you are a complete cynic and believe nothing, you do nothing and get
40 nowhere, but if you believe too much, you fool yourself.”

It was in the early 1980s when the small-comet theory started to haunt Frank and Sigwarth, who was Frank’s graduate student studying charged particles called plasmas, which erupt from the sun and cause the
45 aurora borealis (northern lights). As they analyzed photos of the electrical phenomena that accompany sunspots, they noted dark specks appearing in several images from NASA’s Dynamics Explorer 1 satellite. They assumed these were caused by static in the transmission.
50

After a while their curiosity about the dark spots grew into a preoccupation, then bordered on obsession.

Try as they did, the scientists couldn’t find any plausible explanation of the pattern of dark spots that
55 appeared on their images. The notion that the equipment was picking up small amounts of water entering Earth’s upper atmosphere kept presenting itself as the most likely answer.

Based on their images, the Iowa scientists estimated 20 comets an hour—each about 30 feet or so
60 across and carrying 100 tons of water—were bombarding the Earth. At that rate, they would produce water vapor that would add about an inch of water to the planet every 10,000 years, Frank concluded. That may
65 not seem like much, but when talking about a planet billions of years old, it adds up.

Such intimate interaction between Earth and space suggests a fundamentally different picture of human evolution—which depends on water—than is commonly presented by scientists. Frank had great difficulty getting his ideas into a physics journal 11 years ago and was almost hooted from the room when he presented his theory at scientific meetings. Despite the derision, colleagues continued to respect Frank’s main-
70 stream work on electrically charged particles in space and the imaging cameras he designed that were taken aboard recent NASA spacecraft to explore Earth’s polar regions.

Unbeknown to most, in addition to gathering information on the northern lights, Frank and Sigwarth designed the equipment to be able to snatch better views of any small comets the spacecraft might happen upon. It was those images from the latest flights that caused even harsh critics of the small-comet theory to
80 concede that some water-bearing objects appear to be entering Earth’s atmosphere with regularity.
85

To be sure, it has not been proved that they are comets, let alone that they have anything to do with the oceans. But Frank’s evidence opens the matter up to
90 study. Had he been a researcher of lesser standing, his theory probably would have died long ago.

31. Which of the following conclusions about new theories in science can reasonably be drawn from the passage?
- A. Important new theories will eventually be accepted, no matter how controversial they are or who proposes them.
 - B. Important but unusual new theories have a better chance at acceptance when they are proposed by well-respected scientists.
 - C. Research on new, nontraditional theories is widely respected within the scientific community.
 - D. Scientists welcome the opportunity to overturn existing ideas in favor of useful new theories.

32. Which of the following best describes how Frank's colleagues perceived him after he first presented the small-comet theory?
- F. Their doubts about the theory led them to also question his work on particles in space.
 - G. They felt his theory had ruined his reputation as a widely respected scientist.
 - H. He acquired a reputation among them as someone who had worked hard to develop his theory.
 - J. They still respected his traditional research but felt he was overly committed to an improbable theory.
33. The passage indicates that at the time Frank and Sigwarth presented new evidence supporting the small-comet theory, Frank most nearly felt:
- A. relieved but bitter about how he had been treated.
 - B. grateful that ridicule of his work would end.
 - C. proud that he had been proved right.
 - D. satisfied and filled with anticipation of glory.
34. The author uses the fourth paragraph (lines 27–33) primarily to:
- F. continue his earlier criticisms of scientists.
 - G. reveal the role science serves in society.
 - H. present then undermine common perceptions of scientists.
 - J. explain the difference between theoretical and practical scientific research.
35. According to the passage, the research that led to the development of the small-comet theory began with a project originally intended to study:
- A. the electrical activity accompanying sunspots.
 - B. water entering Earth's upper atmosphere.
 - C. static in satellite transmissions.
 - D. specks in satellite images.
36. The main function of lines 64–66 in terms of the eighth paragraph (lines 59–66) as a whole is to:
- F. give a sense of proportion to the numbers provided earlier in the paragraph.
 - G. point out the limitations of the evidence provided by the Iowa scientists.
 - H. supplement the paragraph's description of the comets with additional details about their size and capacity.
 - J. provide readers with a sense of how old the planet really is.
37. It can reasonably be inferred from the passage that within the scientific community the year the passage was published, the small-comet theory was:
- A. tremendously unpopular and condemned for its incompleteness.
 - B. widely accepted and seen as conclusive.
 - C. regarded as tentative but deemed worthy of consideration.
 - D. seen as correct by most scientists but was highly criticized by some.
38. The author italicizes the word *something* in line 18 most likely to emphasize the:
- F. great skepticism with which critics regard Frank and Sigwarth's new evidence.
 - G. remaining uncertainty about what exactly is bombarding Earth.
 - H. lack of doubt among scientists about the small-comet theory's practical value.
 - J. concern among scientists about the usefulness of Frank and Sigwarth's methods of collecting evidence.
39. When Richard Zare says that scientists lead a "constant schizophrenic existence" (lines 34–35), he most nearly means that they:
- A. often suffer psychologically from the demands of their work.
 - B. tend to be either complete cynics or people who believe too much.
 - C. are often guilty of either doing nothing or of fooling themselves.
 - D. have to maintain a balance between accepting and challenging ideas.
40. It can reasonably be inferred that Frank and Sigwarth conducted the study of the dark specks they found with a:
- F. detached, scientific mindset.
 - G. casual interest that developed into a mild curiosity.
 - H. steadily increasing level of involvement.
 - J. great intensity that began when they discovered the specks.

END OF TEST 3

STOP! DO NOT TURN THE PAGE UNTIL TOLD TO DO SO.

DO NOT RETURN TO A PREVIOUS TEST.



SCIENCE TEST

35 Minutes—40 Questions

DIRECTIONS: There are seven passages in this test. Each passage is followed by several questions. After reading a passage, choose the best answer to each question and fill in the corresponding oval on your answer document. You may refer to the passages as often as necessary.

You are NOT permitted to use a calculator on this test.

Passage I

Many bacteria contain *plasmids* (small, circular DNA molecules). Plasmids can be transferred from 1 bacterium to another. For this to occur, the plasmid *replicates* (produces a linear copy of itself). The relative position of the genes is the same on the original plasmid and on the linear copy, except that the 2 ends of the linear copy do not immediately connect.

While replication is occurring, 1 end of the linear copy leaves the donor bacterium and enters the recipient bacterium. Thus, the order in which the genes are replicated is the same as the order in which they are transferred. Unless this process is interrupted, the entire plasmid is transferred, and its 2 ends connect in the recipient bacterium.

Four students studied the way in which 6 genes (F, X, R, S, A, and G) on a specific plasmid were donated by a type of bacterium (see the figure). The students determined that the entire plasmid is transferred in 90 min and that the rate of transfer is constant. They also determined that the genes are evenly spaced around the plasmid, so 1 gene is transferred every 15 min. They disagreed, however, about the order in which the genes are replicated and thus transferred. Four models are presented.

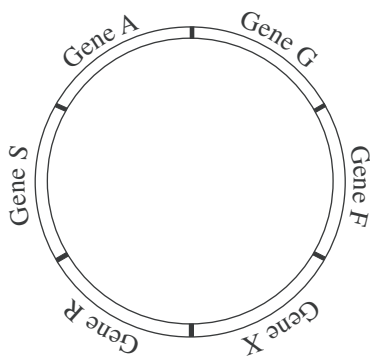

Student 1

Replication always begins between Gene F and Gene X. Gene X is replicated first and Gene F is replicated last.

Student 2

Replication always begins between Gene F and Gene X. However, the direction of replication varies. If Gene F is replicated first, Gene X is replicated last. Conversely, if Gene X is replicated first, Gene F is replicated last.

Student 3

Replication can begin between any 2 genes. Replication then proceeds around the plasmid in a clockwise direction (with respect to the figure). Thus, if Gene S is replicated first, Gene A is replicated second, and Gene R is replicated last.

Student 4

Replication can begin between any 2 genes. Likewise, replication can proceed in either direction. So the order of replication varies.

- Based on the information presented, if the transfer of the linear copy was interrupted 50 min after transfer began, how many complete genes would have been transferred to the recipient bacterium?

A. 2
B. 3
C. 4
D. 5

- Based on the model presented by Student 3, if all 6 genes are replicated and the first gene replicated is Gene G, the third gene replicated would be:

F. Gene F.
G. Gene A.
H. Gene S.
J. Gene X.



3. Which students believe that any of the 6 genes on the plasmid can be the first gene transferred to a recipient bacterium?
- A. Students 2 and 3
 - B. Students 2 and 4
 - C. Students 3 and 4
 - D. Students 2, 3, and 4
4. Suppose that the model presented by Student 1 is correct and that the transfer of genes between 2 bacteria was interrupted after 45 min. Based on the information provided, which of the following genes would NOT have been transferred from the donor bacterium to the recipient bacterium?
- F. Gene G
 - G. Gene X
 - H. Gene R
 - J. Gene S
5. Suppose that Student 2's model is correct and that the transfer of genes between 2 bacteria was interrupted after 30 min. Under these conditions, which of the following genes would definitely NOT be transferred from the donor bacterium to the recipient bacterium?
- A. Gene A
 - B. Gene R
 - C. Gene G
 - D. Gene X
6. Suppose that all 6 genes are transferred from a donor bacterium to a recipient bacterium. Under this condition, which student(s) would argue that Gene A could be the last gene transferred?
- F. Student 2 only
 - G. Student 4 only
 - H. Students 2 and 4 only
 - J. Students 3 and 4 only
7. Suppose that the transfer of genes between 2 bacteria was interrupted, that the last gene transferred was Gene A, and that no incomplete copies of a gene were transferred. Based on this information, Student 1 would say that transfer was most likely interrupted how many minutes after the transfer began?
- A. 15
 - B. 30
 - C. 45
 - D. 60

**Passage II**

Color images of the surface of Io, one of Jupiter's moons, show plumes of gas that resemble Earth's geysers and active volcanoes that emit flows of molten material. The materials ejected from Io's volcanoes and plumes rapidly solidify at Io's cold surface temperatures. Scientists believe that these materials may be one of several *allotropes* (forms) of sulfur (S), or a sulfur compound. The following studies were performed to determine the composition of these materials.

Study 1

In a laboratory, scientists measured the *reflectances* (the fraction of light striking a surface that is reflected by that surface) of 4 allotropes of S (red, white, orange, and brown) and of a sulfur compound (sulfur dioxide [SO_2]). Reflectances were measured at visible-light wavelengths between $0.35 \mu\text{m}$ (micrometers) and $0.60 \mu\text{m}$. Figure 1 shows the data for the various S allotropes and for SO_2 .

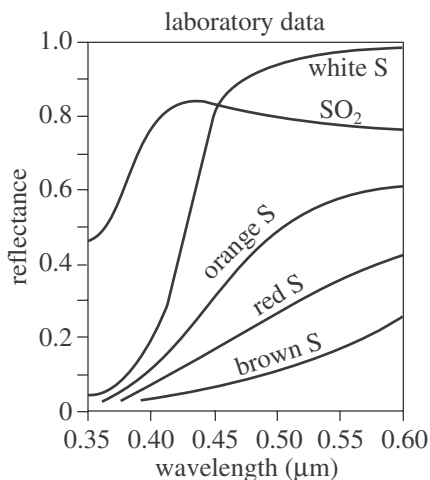

Figure 1

Io's *whole-disk reflectance* (the reflectance of Io's entire visible surface measured all at once) was measured at 2 different times. Figure 2 shows these data along with reflectance data calculated using a computer model. This model shows what combination of materials from Figure 1 would produce the closest match to the measured reflectance data. According to the model, the overall composition of Io's surface is 15% SO_2 , 50% orange S, 20% red S, and 15% white S.

whole-disk data and computer model

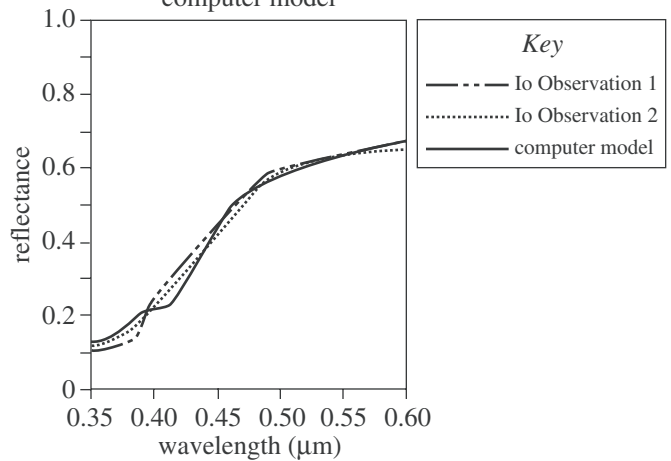

Figure 2

Study 2

At 2 different times, reflectances were measured of the crater floors of 2 volcanoes on Io: Pele and Surt. Figure 3 shows the reflectance data.

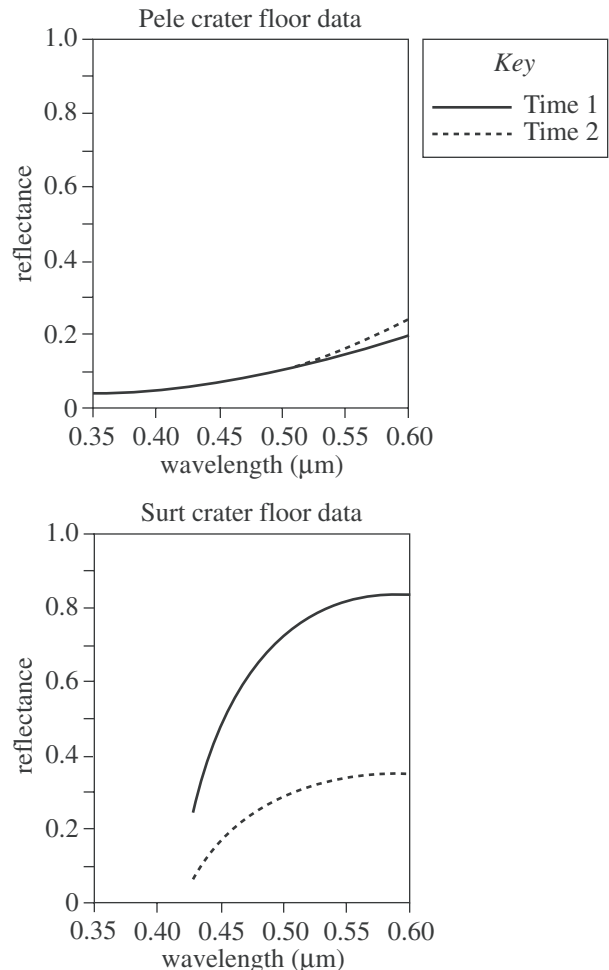

Figure 3



Study 3

Reflectance data were taken from several large plumes and several small plumes on Io. The averaged data are in Figure 4.

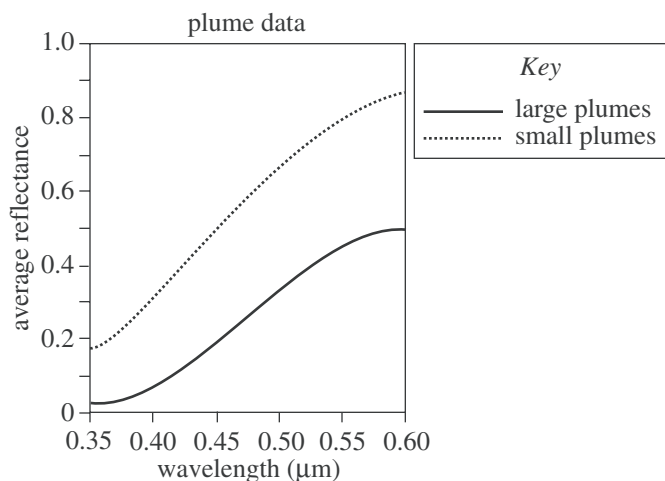

Figure 4

Figures 1, 3, and 4 adapted from Alfred McEwen and Laurence Soderblom, "Two Classes of Volcanic Plumes on Io." ©1983 by Academic Press, Inc.

Figure 2 adapted from Julianne Moses and Douglas Nash, "Phase Transformations and the Spectral Reflectance of Solid Sulfur: Can Metastable Sulfur Allotropes Exist on Io?" ©1991 by Academic Press, Inc.

8. At the wavelengths used in Study 1, as the wavelength of the light increases, the reflectances of the S allotropes and of SO₂ do which of the following?

	S allotropes	SO ₂
F.	Increase only	Increase only
G.	Increase only	Increase, then decrease
H.	Decrease only	Decrease only
J.	Decrease only	Increase, then decrease

9. According to Study 3, compared with the corresponding average reflectance for small plumes, large plumes on Io have an average reflectance at a given wavelength that is:

- A. always higher.
 B. always the same.
 C. always lower.
 D. sometimes higher and sometimes lower.

10. According to Study 1, the reflectance of white S at a wavelength of 0.40 μm is closest to which of the following?

- F. 0.0
 G. 0.1
 H. 0.2
 J. 0.3

11. According to Study 1 and Study 2, the crater floor of the volcano Pele has reflectances most similar to which of the following S allotropes?

- A. White S
 B. Orange S
 C. Red S
 D. Brown S

12. If the averaged reflectances for large plumes and for small plumes had been measured at a wavelength of 0.61 μm in Study 3, those reflectances would have been closest to which of the following?

	Large plumes	Small plumes
F.	0.2	0.5
G.	0.5	0.2
H.	0.5	0.9
J.	0.9	0.5

13. According to Study 1, white S has a reflectance of 0.98 at a wavelength of 0.60 μm. This means that white S reflects:

- A. 2% of the 0.60 μm wavelength light that strikes its surface.
 B. 98% of the 0.60 μm wavelength light that strikes its surface.
 C. 2% of all the visible light that strikes its surface.
 D. 98% of all the visible light that strikes its surface.

**Passage III**

An electrical circuit contained a 12-volt (V) battery, a *resistor* (a device that resists the flow of electricity), a *capacitor* (a device that stores electrical charge and electrical energy), a *voltmeter* (an instrument for measuring voltage), and a switch, as shown in Figure 1.

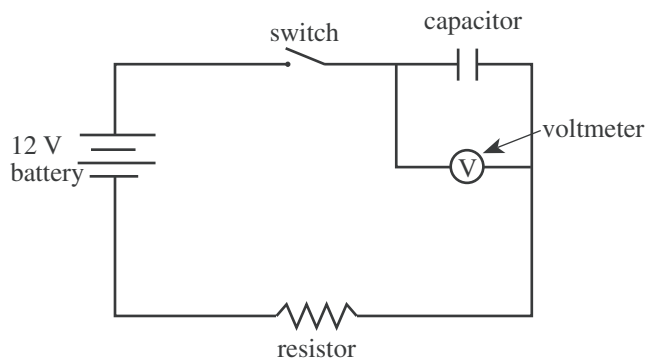

Figure 1

Some students studied the behavior of the circuit.

Experiment 1

The students used a 1×10^7 ohm (Ω) resistor and a capacitor with a *capacitance* of 1×10^{-6} farad (F). (Capacitance is a measure of the maximum amount of electrical charge and electrical energy a capacitor can store.) The capacitor was initially uncharged. At time zero, the students simultaneously closed the switch and started a stopwatch. At time zero and at 12 sec intervals thereafter, they recorded the voltage across the capacitor. Their results are shown in Table 1.

Time (sec)	Voltage across capacitor (V)
0	0.0
12	8.4
24	10.9
36	11.7
48	11.9
60	12.0

Experiment 2

Using the $1 \times 10^7 \Omega$ resistor and several different capacitors, the students determined the length of time from when the switch was closed until the voltage across the capacitor reached 6 V. Their results are shown in Table 2.

Capacitance ($\times 10^{-6}$ F)	Time to reach 6 V across capacitor (sec)
1.2	8.3
0.6	4.2
0.3	2.1
0.1	0.7

Experiment 3

The students conducted the same procedure described in Experiment 2, except that they used a constant capacitance of 1×10^{-6} F and several different resistors. Their results are shown in Table 3.

Resistance ($\times 10^7 \Omega$)	Time to reach 6 V across capacitor (sec)
0.75	5.2
0.50	3.5
0.25	1.7

14. In Experiment 1, the *time constant* of the circuit was the time required for the voltage across the capacitor to reach approximately 7.6 V. The time constant of the circuit used in Experiment 1 was:

- F. less than 12 sec.
- G. between 12 sec and 24 sec.
- H. between 24 sec and 36 sec.
- J. greater than 36 sec.

15. If, in Experiment 2, a 1.5×10^{-6} F capacitor had been used, the time required for the voltage across the capacitor to reach 6 V would have been closest to:

- A. 4.2 sec.
- B. 7.0 sec.
- C. 10.5 sec.
- D. 15.0 sec.



16. The main purpose of Experiment 3 was to determine how varying the:

- F. battery's voltage affected the resistor's resistance at a given time.
- G. capacitor's capacitance affected the time required for the voltage across the capacitor to reach a set value.
- H. capacitor's capacitance affected the voltage across the battery at a given time.
- J. resistor's resistance affected the time required for the voltage across the capacitor to reach a set value.

17. Based on Figure 1, to measure the voltage across the resistor only, which of the following circuits should one use?

A.

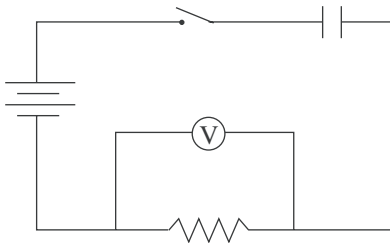

B.

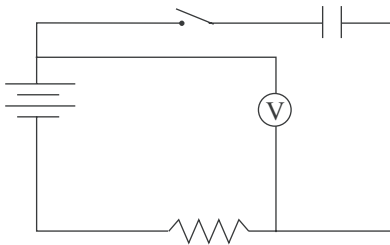

C.

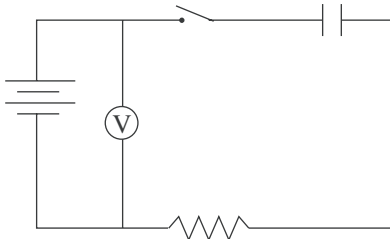

D.

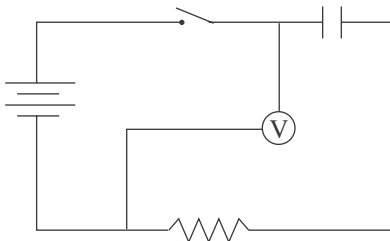

18. Consider a circuit like that shown in Figure 1. Based on Experiments 2 and 3, the voltage across the capacitor will reach a given value in the shortest amount of time if the circuit contains which of the following capacitances and resistances, respectively?

- F. 0.1×10^{-6} F, $0.3 \times 10^7 \Omega$
- G. 0.1×10^{-6} F, $1.0 \times 10^7 \Omega$
- H. 1.2×10^{-6} F, $0.3 \times 10^7 \Omega$
- J. 1.2×10^{-6} F, $1.0 \times 10^7 \Omega$

19. Consider the following hypothesis: In a circuit arranged as in Figure 1 containing a battery, a capacitor, and a constant resistance, as capacitance increases, the time required to reach a given voltage across the capacitor increases. Do the experiments support this hypothesis?

- A. Yes; in Experiment 1, as capacitance increased, the time required to reach a given voltage increased.
- B. Yes; in Experiment 2, as capacitance increased, the time required to reach a given voltage increased.
- C. No; in Experiment 1, as capacitance increased, the time required to reach a given voltage decreased.
- D. No; in Experiment 2, as capacitance increased, the time required to reach a given voltage decreased.

Passage IV

A *bomb calorimeter* is used to determine the amount of heat released when a substance is burned in oxygen (Figure 1). The heat, measured in kilojoules (kJ), is calculated from the change in temperature of the water in the bomb calorimeter. Table 1 shows the amounts of heat released when different foods were burned in a bomb calorimeter. Table 2 shows the amounts of heat released when different amounts of sucrose (table sugar) were burned. Table 3 shows the amounts of heat released when various chemical compounds were burned.

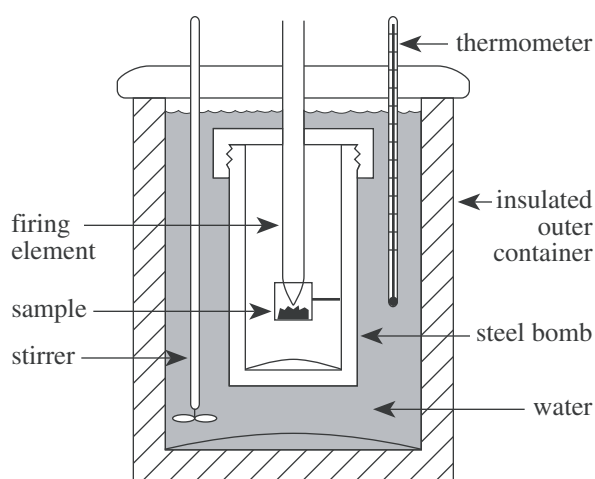

Figure 1

Figure 1 adapted from Antony C. Wilbraham, Dennis D. Staley, and Michael S. Matta, *Chemistry*. ©1995 by Addison-Wesley Publishing Company, Inc.

Food	Mass (g)	Change in water temperature (°C)	Heat released (kJ)
Bread	1.0	8.3	10.0
Cheese	1.0	14.1	17.0
Egg	1.0	5.6	6.7
Potato	1.0	2.7	3.2

Table 1 adapted from American Chemical Society, *ChemCom: Chemistry in the Community*. ©1993 by American Chemical Society.

Amount of sucrose (g)	Heat released (kJ)
0.1	1.6
0.5	8.0
1.0	16.0
2.0	32.1
4.0	64.0

Chemical compound	Molecular formula	Mass (g)	Heat released (kJ)
Methanol	CH ₃ OH	0.5	11.4
Ethanol	C ₂ H ₅ OH	0.5	14.9
Benzene	C ₆ H ₆	0.5	21.0
Octane	C ₈ H ₁₈	0.5	23.9

20. According to Tables 1 and 2, as the mass of successive sucrose samples increased, the change in the water temperature produced when the sample was burned most likely:

F. increased only.
 G. decreased only.
 H. increased, then decreased.
 J. remained the same.



21. Which of the following graphs best illustrates the relationship between the heat released by the foods listed in Table 1 and the change in water temperature?

A.

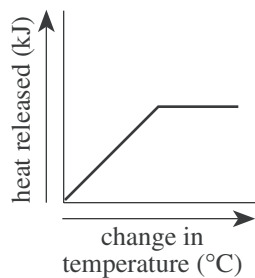

C.

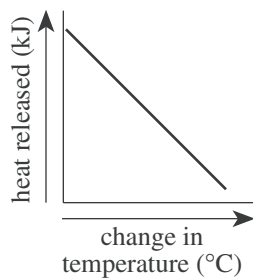

B.

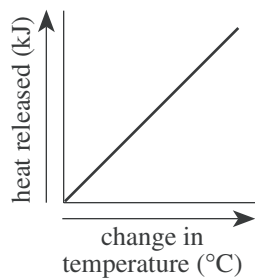

D.

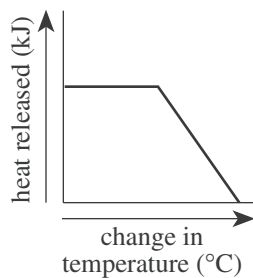

22. Based on the data in Table 2, one can conclude that when the mass of sucrose is decreased by one-half, the amount of heat released when it is burned in a bomb calorimeter will:

- F. increase by one-half.
- G. decrease by one-half.
- H. increase by one-fourth.
- J. decrease by one-fourth.

23. Which of the following lists the foods from Tables 1 and 2 in increasing order of the amount of heat released per gram of food?

- A. Potato, egg, bread, sucrose, cheese
- B. Sucrose, cheese, bread, egg, potato
- C. Bread, cheese, egg, potato, sucrose
- D. Sucrose, potato, egg, bread, cheese

24. Based on the information in Tables 1 and 2, the heat released from the burning of 5.0 g of potato in a bomb calorimeter would be closest to which of the following?

- F. 5 kJ
- G. 10 kJ
- H. 15 kJ
- J. 20 kJ

**Passage V**

Density is defined as the mass of a substance divided by its volume:

$$\text{density} = \frac{\text{mass}}{\text{volume}}$$

Table 1 lists the phases and the densities, in grams per cubic centimeter (g/cm^3), of various pure substances at 25°C and 1 atmosphere (atm) of pressure.

Table 1		
Substance	Phase	Density (g/cm^3)
Arsenic	solid	5.73
Glucose	solid	1.56
Iron	solid	7.86
Lead	solid	11.34
Zinc	solid	7.14
Ethanol	liquid	0.79
Ethyl ether	liquid	0.71
Glycerol	liquid	1.26
Mercury	liquid	13.59
Freon-12	gas	0.00495
Krypton	gas	0.00343
Methane	gas	0.00065

Figure 1 shows how the density of liquid water changes with temperature.

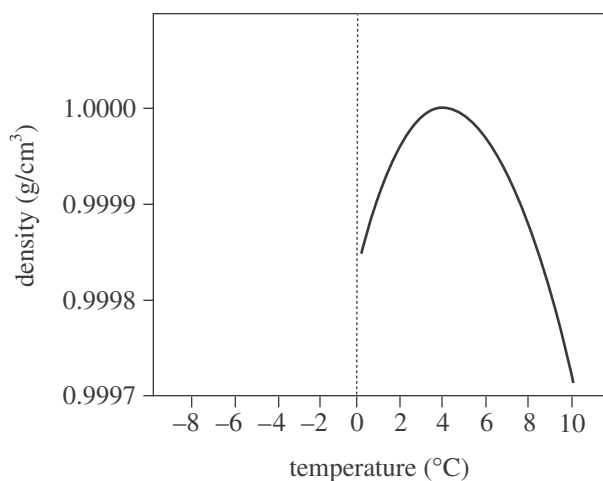

Figure 1

Figure 2 shows how the density of solid water changes with temperature.

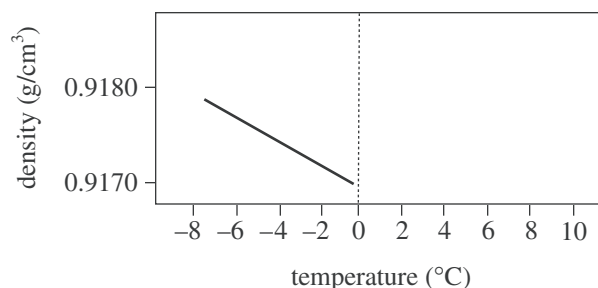

Figure 2

Figures adapted from John C. Kotz and Keith F. Purcell, *Chemistry & Chemical Reactivity*. ©1987 by CBS College Publishing.

25. According to Figure 1, as the temperature of liquid water decreases from 10°C to 0°C , the density:
- increases only.
 - decreases only.
 - decreases, then increases.
 - increases, then decreases.
26. A student claimed that "If the masses of 1 cm^3 of any solid and 1 cm^3 of any liquid are compared, the mass of the solid will be greater." Do the data in Table 1 support his claim?
- No; lead has a higher density than any of the liquids listed.
 - No; mercury has a higher density than any of the solids listed.
 - Yes; lead has a higher density than any of the liquids listed.
 - Yes; mercury has a higher density than any of the solids listed.
27. Which of the following hypotheses about the relationship between the temperature and the density of a solid is best supported by the data in Figure 2? As the temperature of a solid increases, the density of the solid:
- increases only.
 - decreases only.
 - increases, then decreases.
 - decreases, then increases.



28. Equal amounts of ethyl ether, mercury, and water (density = 0.9971 g/cm^3) at 25°C are poured into a single beaker. Three distinct layers of liquid form in the beaker. Based on the data in Table 1, which of the following diagrams represents the order, from top to bottom, of the liquids in the beaker?

F.

Ethyl ether
Water
Mercury

G.

Ethyl ether
Mercury
Water

H.

Mercury
Water
Ethyl ether

J.

Water
Ethyl ether
Mercury

29. According to Figure 1, 100 g of water at 4°C would exactly fill a container having which of the following volumes?

- A. 1 cm^3
 B. 10 cm^3
 C. 100 cm^3
 D. $1,000 \text{ cm}^3$

**Passage VI**

The clearing of rain forests results in *forest fragmentation* (the breakup of large forest tracts into small patches). Researchers predicted that fragmentation would result in a decrease in animal populations and *aboveground tree biomass* (AGTB) in the resulting fragments. They did 4 studies to test this prediction.

Study 1

The researchers monitored the AGTB of twenty-five 100 m × 100 m forest plots near areas that had recently been cleared of vegetation. The distance from the center of each plot to the nearest clearing was measured. Figure 1 shows the average change per plot in AGTB in metric tons per year (t/yr) over 17 yr.

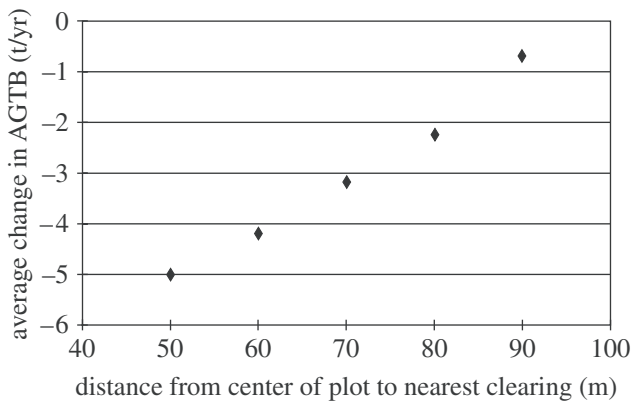

Figure 1

Study 2

Twenty-five 100 m × 100 m forest plots were monitored as in Study 1. The center of each of these plots was at least 500 m from the nearest clearing. The average change in AGTB over 17 yr for these 25 plots was 0 t/yr.

Study 3

Researchers monitored sixteen 100 m × 100 m forest plots near areas that had recently been cleared of vegetation. Each plot was bordered on 1 side by a clearing. Figure 2 shows the average cumulative percent change in AGTB at these plots following fragmentation. (Note: Year 0 represents results prior to fragmentation.)

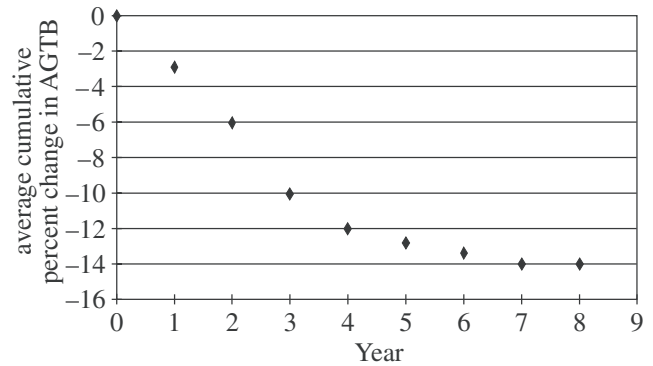

Figure 2

Study 4

Researchers trapped and released birds in 10 forest fragments adjacent to areas that had recently been cleared of vegetation. Three types of birds were monitored: insectivores, frugivores (fruit eaters), and hummingbirds. Figure 3 shows the number of captures per 1,000 hours (hr) of trapping. (Note: Year 0 represents results prior to fragmentation.)

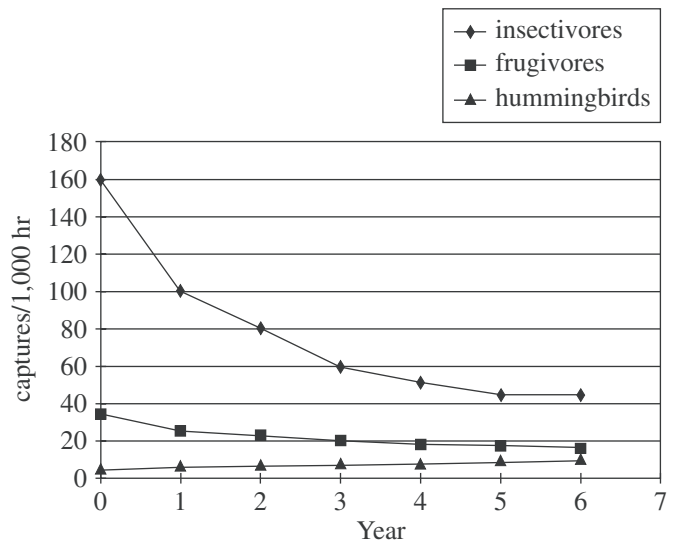
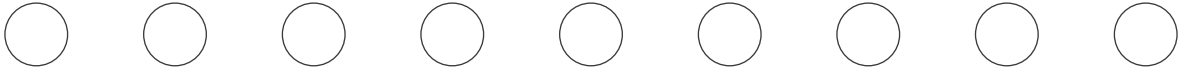

Figure 3

Figures adapted from William F. Laurance et al., "Biomass Collapse in Amazonian Forest Fragments." ©1998 by the American Association for the Advancement of Science.



30. In Study 4, as time increased from Year 0 to Year 6, the captures/1,000 hr of frugivores:
- F. decreased only.
 - G. increased only.
 - H. decreased, then increased.
 - J. increased, then decreased.
31. Based on the results of Study 4, how did fragmentation most likely affect the population sizes of insectivores and hummingbirds in the fragments studied?
- A. Fragmentation increased the population sizes of both insectivores and hummingbirds.
 - B. Fragmentation decreased the population sizes of both insectivores and hummingbirds.
 - C. Fragmentation increased the population size of insectivores and decreased the population size of hummingbirds.
 - D. Fragmentation decreased the population size of insectivores and increased the population size of hummingbirds.
32. Based on the results of Study 1, if the distance from the center of a $100\text{ m} \times 100\text{ m}$ plot were 75 m from the nearest clearing, the expected average change in AGTB at the plot over 17 yr would be closest to which of the following values?
- F. -1.1 t/yr
 - G. -2.6 t/yr
 - H. $+1.1\text{ t/yr}$
 - J. $+2.6\text{ t/yr}$
33. After examining the results of Study 2, a student concluded that the AGTB at each of the 25 plots remained constant. Which of the following alternative explanations is also consistent with the results?
- A. The AGTB at all 25 plots increased.
 - B. The AGTB at all 25 plots decreased.
 - C. The AGTB at some of the plots increased and the AGTB at some of the plots decreased.
 - D. The AGTB at plots bounded by forest increased and the AGTB at plots bounded by clearings remained constant.
34. Which of the following sets of results from the studies is *least* consistent with the prediction proposed by the researchers?
- F. The results of Study 1 for AGTB
 - G. The results of Study 3 for AGTB
 - H. The results of Study 4 for frugivores
 - J. The results of Study 4 for hummingbirds
35. In Study 4, the researchers trapped birds for 10,000 hr per year. Thus, how many insectivores were trapped in Year 2 ?
- A. 80
 - B. 100
 - C. 800
 - D. 1,000



Passage VII

Glaciers deposit *till* (a poorly sorted sediment). If glaciers repeatedly advance over an area and then melt back, thick till deposits may form. Figure 1 shows a vertical core taken through layers of till, non-glacial sediments, and bedrock at a site in Canada. The *resistivity* (an electrical property of a material) and CO₂ measurements taken along the core are also shown. Resistivity is related to a sediment's particle sizes, compaction, and mineral composition. Table 1 shows the average percent sand, silt, and clay contents and descriptions of the various till layers.

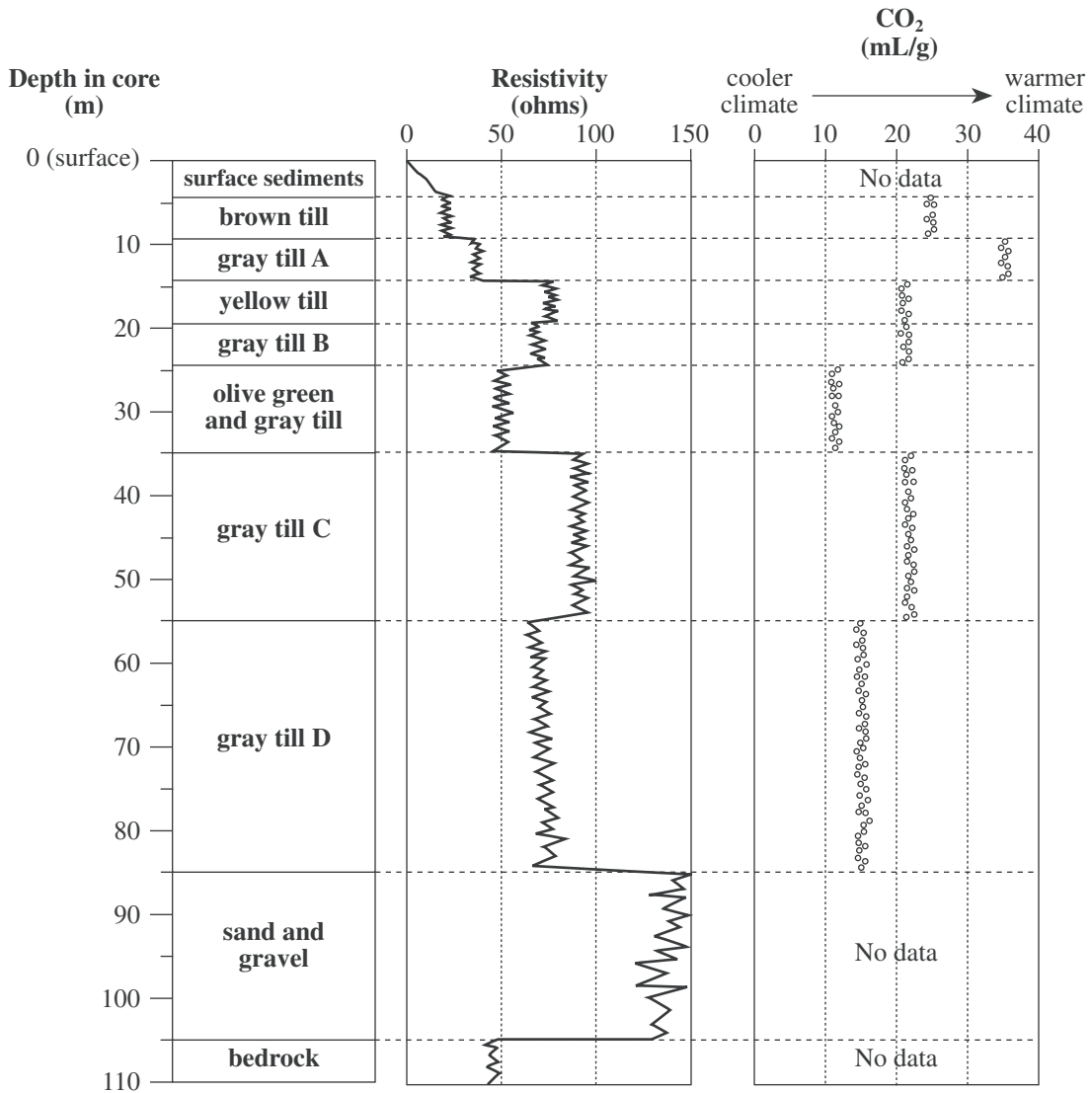

Figure 1



Depth of till layer (m)	Description of till	Average percent by volume of:		
		larger particle → smaller particle		
		sand	silt	clay
4–9	brown (oxidized*)	54.1	31.7	14.2
9–14	gray A	44.8	36.6	18.6
14–19	yellow (oxidized)	43.5	31.7	24.8
19–24	gray B	37.4	34.3	28.3
24–35	olive green and gray	25.5	34.3	40.2
35–55	gray C	31.7	33.6	34.7
55–85	gray D	37.5	31.7	30.8

*Oxidized sediments have at some time been exposed to the air. Sediments that have been *deprived* of oxygen will be gray or green.

Figure 1 and Table 1 adapted from E. A. Christiansen, "Pleistocene Stratigraphy of the Saskatoon Area, Saskatchewan, Canada: An Update." ©1992 by the Geological Association of Canada.

36. A sample of gray till was recovered from another core taken from a nearby area. The table below shows the results of an analysis of the sample.

Percent by volume of:			Resistivity (ohms)	CO ₂ content (mL/g)
sand	silt	clay		
31.5	33.7	34.8	85	22

Based on these data and the data provided in Figure 1 and Table 1, the sample of gray till corresponds most closely with which till from Figure 1 ?

- F. Gray till A
 G. Gray till B
 H. Gray till C
 J. Gray till D
37. According to Figure 1, the *oldest* glacial advance in this area deposited which of the following till layers?
 A. Gray till A
 B. Yellow till
 C. Olive green and gray till
 D. Gray till D
38. According to Figure 1, which of the following statements best describes how the resistivity of the sand and gravel layer compares to the resistivity of the till layers? The resistivity measured in the sand and gravel layer is:
 F. lower than the resistivities measured in any of the till layers.
 G. higher than the resistivities measured in any of the till layers.
 H. the same as the resistivities measured in the surface sediments.
 J. lower than the resistivities measured in the bedrock.
39. The average resistivity of the bedrock in the core is most similar to the average resistivity of which of the following till layers?
 A. Yellow till
 B. Gray till B
 C. Olive green and gray till
 D. Gray till C
40. The sediments being deposited at the present time at the site where the core was taken have a much higher CO₂ content than any of the tills. Given this information and the information in Figure 1, the CO₂ content of sediments recently deposited at the site would most likely be in which of the following ranges?
 F. Less than 10 mL/g
 G. Between 10 mL/g and 25 mL/g
 H. Between 25 mL/g and 35 mL/g
 J. Greater than 35 mL/g

END OF TEST 4

STOP! DO NOT RETURN TO ANY OTHER TEST.

[See Note on page 56.]

Practice Writing Test

Your Signature (do not print): _____

Print Your Name Here: _____

Your Date of Birth:									
<input type="text"/>	<input type="text"/>	-	<input type="text"/>	<input type="text"/>	-	<input type="text"/>	<input type="text"/>	<input type="text"/>	<input type="text"/>
Month		Day		Year					

Form 06A

ACT ASSESSMENT® WRITING TEST BOOKLET



Directions

This is a test of your writing skills. You will have thirty (30) minutes to write an essay in English. Before you begin planning and writing your essay, read the writing prompt carefully to understand exactly what you are being asked to do. Your essay will be evaluated on the evidence it provides of your ability to express judgments by taking a position on the issue in the writing prompt; to maintain a focus on the topic throughout the essay; to develop a position by using logical reasoning and by supporting your ideas; to organize ideas in a logical way; and to use language clearly and effectively according to the conventions of standard written English.

You may use the unlined pages in this test booklet to plan your essay. These pages will not be scored. ***You must write your essay in pencil on the lined pages in the answer folder.*** Your writing on those lined pages will be scored. You may not need all the lined pages, but to ensure you have enough room to finish, do NOT skip lines. You may write corrections or additions neatly between the lines of your essay, but do NOT write in the margins of the lined pages. ***Illegible essays cannot be scored, so you must write (or print) clearly.***

If you finish before time is called, you may review your work. Lay your pencil down immediately when time is called.

DO NOT OPEN THIS BOOKLET UNTIL TOLD TO DO SO.

ACT Assessment Writing Test Prompt

Many high school libraries use some of their limited funding to subscribe to popular magazines with articles that are interesting to students. Despite limited funding, some educators support this practice because they think having these magazines available encourages students to read. Other educators think school libraries should not use limited funds to subscribe to these magazines because they may not be related to academic subjects. In your opinion, should high school libraries subscribe to popular magazines?

In your essay, take a position on this question. You may write about either one of the two points of view given, or you may present a different point of view on this question. Use specific reasons and examples to support your position.

Note

- Your actual test booklet will have blank space for you to plan your essay. For this practice test, you can use scratch paper.
- You may wish to remove pages 75–78 to respond to this prompt.
- When you have finished, read pages 66–72 for information and instructions on scoring your practice Writing Test.

Please enter the information at the right before beginning the Writing Test.

Use a soft lead No. 2 pencil only. Do NOT use a mechanical pencil, ink, ballpoint, or felt-tip pen.

WRITING TEST BOOKLET NUMBER

Print your 6-digit Booklet Number in the boxes at the right.

--	--	--	--	--	--

WRITING TEST FORM

○ 06A

--	--	--

Print your 3-character Test Form in the boxes above and fill in the corresponding oval at the right.

Begin WRITING TEST here.

If you need more space, please continue on the next page.

Do not write in this shaded area.

Cut Here

WRITING TEST

Lined writing area with 25 horizontal lines.

If you need more space, please continue on the next page.

3

Cut Here

PLEASE DO NOT WRITE IN THIS AREA.



SERIAL #

Scoring Keys for the ACT Practice Tests

Use the scoring key for each test to score your answer document for the multiple-choice tests. Mark a "1" in the blank for each question you answered correctly. Add up the numbers in each subscore area and enter the total number correct for each subscore area in the blanks provided. Also enter the total number correct for each test in the blanks provided. The total number correct for each test is the sum of the number correct in each subscore area.

Test 1: English—Scoring Key

		Subscore Area*				Subscore Area*				Subscore Area*	
	Key	UM	RH		Key	UM	RH		Key	UM	RH
1.	D		_____	26.	F		_____	51.	C		_____
2.	F		_____	27.	A	_____	_____	52.	H	_____	_____
3.	B	_____	_____	28.	H	_____	_____	53.	B	_____	_____
4.	J	_____	_____	29.	D	_____	_____	54.	J	_____	_____
5.	A	_____	_____	30.	G	_____	_____	55.	D	_____	_____
6.	G	_____	_____	31.	C	_____	_____	56.	J	_____	_____
7.	A	_____	_____	32.	J	_____	_____	57.	C	_____	_____
8.	G	_____	_____	33.	A	_____	_____	58.	H	_____	_____
9.	A	_____	_____	34.	H	_____	_____	59.	B	_____	_____
10.	J		_____	35.	C	_____	_____	60.	J	_____	_____
11.	C	_____	_____	36.	G	_____	_____	61.	C	_____	_____
12.	J	_____	_____	37.	D	_____	_____	62.	F	_____	_____
13.	A		_____	38.	H	_____	_____	63.	B	_____	_____
14.	G	_____	_____	39.	A	_____	_____	64.	F	_____	_____
15.	C		_____	40.	J	_____	_____	65.	D	_____	_____
16.	J		_____	41.	C	_____	_____	66.	H	_____	_____
17.	B	_____	_____	42.	F	_____	_____	67.	B	_____	_____
18.	J		_____	43.	C	_____	_____	68.	G	_____	_____
19.	A		_____	44.	F	_____	_____	69.	C	_____	_____
20.	F		_____	45.	D	_____	_____	70.	J	_____	_____
21.	C		_____	46.	G	_____	_____	71.	D	_____	_____
22.	F	_____	_____	47.	A	_____	_____	72.	F	_____	_____
23.	A	_____	_____	48.	G	_____	_____	73.	B	_____	_____
24.	J	_____	_____	49.	D	_____	_____	74.	H	_____	_____
25.	B	_____	_____	50.	G	_____	_____	75.	D	_____	_____

Number Correct (Raw Score) for:	
Usage/Mechanics (UM) Subscore Area	_____ (40)
Rhetorical Skills (RH) Subscore Area	_____ (35)
Total Number Correct for English Test (UM + RH)	_____ (75)

* UM = Usage/Mechanics
RH = Rhetorical Skills

0661C

Test 2: Mathematics—Scoring Key

		Subscore Area*					Subscore Area*		
	Key	EA	AG	GT		Key	EA	AG	GT
1.	A	_____			31.	E		_____	
2.	K	_____			32.	F			_____
3.	B	_____			33.	C	_____		
4.	G		_____		34.	J	_____		
5.	E	_____			35.	B			_____
6.	H	_____			36.	K		_____	
7.	E	_____			37.	C		_____	
8.	G	_____			38.	J		_____	
9.	B			_____	39.	C			_____
10.	J		_____		40.	H		_____	
11.	E	_____			41.	A	_____		
12.	J		_____		42.	F		_____	
13.	B	_____			43.	D		_____	
14.	G			_____	44.	F			_____
15.	C			_____	45.	C			_____
16.	G			_____	46.	K			_____
17.	A	_____			47.	C	_____		
18.	H			_____	48.	J	_____		
19.	C	_____			49.	D		_____	
20.	K	_____			50.	J		_____	
21.	B	_____			51.	E	_____		
22.	K		_____		52.	J	_____		
23.	A	_____			53.	A		_____	
24.	F	_____			54.	K			_____
25.	D			_____	55.	B			_____
26.	J		_____		56.	H			_____
27.	A	_____			57.	A		_____	
28.	H	_____			58.	K			_____
29.	C			_____	59.	E		_____	
30.	G			_____	60.	J		_____	

Number Correct (Raw Score) for:	
Pre-Alg./Elem. Alg. (EA) Subscore Area	_____ (24)
Inter. Alg./Coord. Geo. (AG) Subscore Area	_____ (18)
Plane Geo./Trig. (GT) Subscore Area	_____ (18)
Total Number Correct for Math Test (EA + AG + GT)	_____ (60)

* EA = Pre-Algebra/Elementary Algebra
 AG = Intermediate Algebra/Coordinate Geometry
 GT = Plane Geometry/Trigonometry

0661C

Test 3: Reading—Scoring Key

		Subscore Area*				Subscore Area*				Subscore Area*	
Key		SS	AL	Key		SS	AL	Key		SS	AL
1.	B		_____	15.	D	_____		29.	C		_____
2.	J		_____	16.	G	_____		30.	G		_____
3.	C		_____	17.	A	_____		31.	B	_____	
4.	F		_____	18.	F	_____		32.	J	_____	
5.	C		_____	19.	C	_____		33.	B	_____	
6.	J		_____	20.	H	_____		34.	H	_____	
7.	A		_____	21.	A		_____	35.	A	_____	
8.	H		_____	22.	H		_____	36.	F	_____	
9.	D		_____	23.	C		_____	37.	C	_____	
10.	G		_____	24.	J		_____	38.	G	_____	
11.	B	_____		25.	D		_____	39.	D	_____	
12.	F	_____		26.	G		_____	40.	H	_____	
13.	D	_____		27.	D		_____				
14.	J	_____		28.	F		_____				

Number Correct (Raw Score) for:	
Social Studies/Sciences (SS) Subscore Area	_____ (20)
Arts/Literature (AL) Subscore Area	_____ (20)
Total Number Correct for Reading Test (SS + AL)	_____ (40)

* SS = Social Studies/Sciences
AL = Arts/Literature

Test 4: Science—Scoring Key

Key	Key	Key
1. B	15. C	29. C
2. J	16. J	30. F
3. C	17. A	31. D
4. F	18. F	32. G
5. A	19. B	33. C
6. J	20. F	34. J
7. D	21. B	35. C
8. G	22. G	36. H
9. C	23. A	37. D
10. H	24. H	38. G
11. D	25. D	39. C
12. H	26. G	40. J
13. B	27. B	
14. F	28. F	

Number Correct (Raw Score) for:	
Total Number Correct for Science Test	_____ (40)

0661C

TABLE 1**Procedures Used to Obtain Scale Scores From Raw Scores for the ACT Practice Tests**

On each of the four multiple-choice tests on which you marked any responses, the total number of correct responses yields a raw score. Use the table below to convert your raw scores to scale scores. For each test, locate and circle your raw score or the range of raw scores that includes it in the table below. Then, read across to either outside column of the table and circle the scale score that corresponds to that raw score. As you determine your scale scores, enter them in the blanks provided on the right. The highest possible scale score for each test is 36. The lowest possible scale score for any test on which you marked any response is 1.

Next, compute the Composite score by averaging the four scale scores. To do this, add your four scale scores and divide the sum by 4. If the resulting number ends in a fraction, round it off to the nearest whole number. (Round down any fraction less than one-half; round up any fraction that is one-half or more.) Enter this number in the blank. This is your Composite score. The highest possible Composite score is 36. The lowest possible Composite score is 1.

	<u>Your Scale Score</u>
English	_____
Mathematics	_____
Reading	_____
Science	_____
<hr/>	
Sum of scores	_____
Composite score (sum ÷ 4)	_____

NOTE: If you left a test completely blank and marked no items, do not list a scale score for that test. If any test was completely blank, do not calculate a Composite score.

Scale Score	Raw Scores				Scale Score
	Test 1 English	Test 2 Mathematics	Test 3 Reading	Test 4 Science	
36	75	60	38-40	40	36
35	73-74	58-59	37	—	35
34	71-72	56-57	36	39	34
33	70	55	35	—	33
32	69	54	34	38	32
31	68	52-53	—	—	31
30	67	50-51	33	37	30
29	65-66	48-49	32	36	29
28	64	46-47	30-31	35	28
27	62-63	43-45	29	34	27
26	60-61	41-42	28	32-33	26
25	57-59	39-40	27	30-31	25
24	55-56	37-38	26	29	24
23	53-54	35-36	25	27-28	23
22	50-52	33-34	24	25-26	22
21	47-49	31-32	23	23-24	21
20	44-46	30	22	21-22	20
19	42-43	27-29	21	18-20	19
18	39-41	25-26	20	16-17	18
17	37-38	22-24	19	14-15	17
16	34-36	18-21	17-18	13	16
15	30-33	15-17	16	12	15
14	28-29	12-14	14-15	10-11	14
13	26-27	09-11	12-13	09	13
12	24-25	08	10-11	08	12
11	22-23	06-07	08-09	07	11
10	20-21	05	07	06	10
9	18-19	04	06	05	9
8	15-17	—	05	04	8
7	13-14	03	—	03	7
6	10-12	02	04	—	6
5	08-09	—	03	02	5
4	06-07	—	02	—	4
3	04-05	01	—	01	3
2	02-03	—	01	—	2
1	00-01	00	00	00	1

Marking Directions: Mark only **one** oval for each question. Fill in response completely. Erase errors cleanly without smudging.

Correct mark:

Do NOT use these incorrect or bad marks.

- Incorrect marks:
- Overlapping mark:
- Cross-out mark:
- Smudged erasure:
- Mark is too light:

BOOKLET NUMBER

1	1	1	1	1	1
2	2	2	2	2	2
3	3	3	3	3	3
4	4	4	4	4	4
5	5	5	5	5	5
6	6	6	6	6	6
7	7	7	7	7	7
8	8	8	8	8	8
9	9	9	9	9	9
0	0	0	0	0	0

FORM

--	--	--

BE SURE TO FILL IN THE CORRECT FORM OVAL.

0661C

Print your 3-character **Test Form** in the boxes above and fill in the corresponding oval at the right.

TEST 1

- | | | | | | |
|------------|------------|------------|------------|------------|------------|
| 1 A B C D | 14 F G H J | 27 A B C D | 40 F G H J | 53 A B C D | 66 F G H J |
| 2 F G H J | 15 A B C D | 28 F G H J | 41 A B C D | 54 F G H J | 67 A B C D |
| 3 A B C D | 16 F G H J | 29 A B C D | 42 F G H J | 55 A B C D | 68 F G H J |
| 4 F G H J | 17 A B C D | 30 F G H J | 43 A B C D | 56 F G H J | 69 A B C D |
| 5 A B C D | 18 F G H J | 31 A B C D | 44 F G H J | 57 A B C D | 70 F G H J |
| 6 F G H J | 19 A B C D | 32 F G H J | 45 A B C D | 58 F G H J | 71 A B C D |
| 7 A B C D | 20 F G H J | 33 A B C D | 46 F G H J | 59 A B C D | 72 F G H J |
| 8 F G H J | 21 A B C D | 34 F G H J | 47 A B C D | 60 F G H J | 73 A B C D |
| 9 A B C D | 22 F G H J | 35 A B C D | 48 F G H J | 61 A B C D | 74 F G H J |
| 10 F G H J | 23 A B C D | 36 F G H J | 49 A B C D | 62 F G H J | 75 A B C D |
| 11 A B C D | 24 F G H J | 37 A B C D | 50 F G H J | 63 A B C D | |
| 12 F G H J | 25 A B C D | 38 F G H J | 51 A B C D | 64 F G H J | |
| 13 A B C D | 26 F G H J | 39 A B C D | 52 F G H J | 65 A B C D | |

TEST 2

- | | | | | | |
|--------------|--------------|--------------|--------------|--------------|--------------|
| 1 A B C D E | 11 A B C D E | 21 A B C D E | 31 A B C D E | 41 A B C D E | 51 A B C D E |
| 2 F G H J K | 12 F G H J K | 22 F G H J K | 32 F G H J K | 42 F G H J K | 52 F G H J K |
| 3 A B C D E | 13 A B C D E | 23 A B C D E | 33 A B C D E | 43 A B C D E | 53 A B C D E |
| 4 F G H J K | 14 F G H J K | 24 F G H J K | 34 F G H J K | 44 F G H J K | 54 F G H J K |
| 5 A B C D E | 15 A B C D E | 25 A B C D E | 35 A B C D E | 45 A B C D E | 55 A B C D E |
| 6 F G H J K | 16 F G H J K | 26 F G H J K | 36 F G H J K | 46 F G H J K | 56 F G H J K |
| 7 A B C D E | 17 A B C D E | 27 A B C D E | 37 A B C D E | 47 A B C D E | 57 A B C D E |
| 8 F G H J K | 18 F G H J K | 28 F G H J K | 38 F G H J K | 48 F G H J K | 58 F G H J K |
| 9 A B C D E | 19 A B C D E | 29 A B C D E | 39 A B C D E | 49 A B C D E | 59 A B C D E |
| 10 F G H J K | 20 F G H J K | 30 F G H J K | 40 F G H J K | 50 F G H J K | 60 F G H J K |

TEST 3

- | | | | | | |
|-----------|------------|------------|------------|------------|------------|
| 1 A B C D | 8 F G H J | 15 A B C D | 22 F G H J | 29 A B C D | 36 F G H J |
| 2 F G H J | 9 A B C D | 16 F G H J | 23 A B C D | 30 F G H J | 37 A B C D |
| 3 A B C D | 10 F G H J | 17 A B C D | 24 F G H J | 31 A B C D | 38 F G H J |
| 4 F G H J | 11 A B C D | 18 F G H J | 25 A B C D | 32 F G H J | 39 A B C D |
| 5 A B C D | 12 F G H J | 19 A B C D | 26 F G H J | 33 A B C D | 40 F G H J |
| 6 F G H J | 13 A B C D | 20 F G H J | 27 A B C D | 34 F G H J | |
| 7 A B C D | 14 F G H J | 21 A B C D | 28 F G H J | 35 A B C D | |

TEST 4

- | | | | | | |
|-----------|------------|------------|------------|------------|------------|
| 1 A B C D | 8 F G H J | 15 A B C D | 22 F G H J | 29 A B C D | 36 F G H J |
| 2 F G H J | 9 A B C D | 16 F G H J | 23 A B C D | 30 F G H J | 37 A B C D |
| 3 A B C D | 10 F G H J | 17 A B C D | 24 F G H J | 31 A B C D | 38 F G H J |
| 4 F G H J | 11 A B C D | 18 F G H J | 25 A B C D | 32 F G H J | 39 A B C D |
| 5 A B C D | 12 F G H J | 19 A B C D | 26 F G H J | 33 A B C D | 40 F G H J |
| 6 F G H J | 13 A B C D | 20 F G H J | 27 A B C D | 34 F G H J | |
| 7 A B C D | 14 F G H J | 21 A B C D | 28 F G H J | 35 A B C D | |

ACT STUDENT REVIEW: The test supervisor will give you instructions for completing this section.



Student Review: Your responses to these items will assist ACT and your test center in providing the best possible conditions for testing and planning for the future. Fill in the oval indicating your response to each item printed on the back of your test booklet.

- | | | | | | |
|-------------------------|-----------------------|--------------------------|-----------------------|--------------------------|-----------------------|
| Yes | No | Yes | No | Yes | No |
| 1 <input type="radio"/> | <input type="radio"/> | 6 <input type="radio"/> | <input type="radio"/> | 11 <input type="radio"/> | <input type="radio"/> |
| 2 <input type="radio"/> | <input type="radio"/> | 7 <input type="radio"/> | <input type="radio"/> | 12 <input type="radio"/> | <input type="radio"/> |
| 3 <input type="radio"/> | <input type="radio"/> | 8 <input type="radio"/> | <input type="radio"/> | 13 <input type="radio"/> | <input type="radio"/> |
| 4 <input type="radio"/> | <input type="radio"/> | 9 <input type="radio"/> | <input type="radio"/> | 14 <input type="radio"/> | <input type="radio"/> |
| 5 <input type="radio"/> | <input type="radio"/> | 10 <input type="radio"/> | <input type="radio"/> | 15 <input type="radio"/> | <input type="radio"/> |