

## COMBO® MODELS REFRIGERATOR / FREEZER MODELS

### COMBO® MODELS



U-CO2175FB-00  
U-CO2175FS-00  
U-CO2175FS-01  
U-CO2175FW-00  
U-CO29B-00  
U-CO29B-03  
U-CO29B-20  
U-CO29BTP-20  
U-CO29FB-00  
U-CO29FB-98  
U-CO29FB-99  
U-CO29FWH-00  
U-CO29WH-03  
U-CO29WHTP-20

### REFRIGERATOR FREEZER MODELS



U-2175RFB-00  
U-2175RFS-00  
U-2175RFS-01  
U-2175RFW-00

### DRAWER COMBO® MODELS



U-C2275DWROL-00  
U-C2275DWRS-00

## Introduction



Congratulations on your purchase of a U-Line refrigerator.

For nearly five decades and three generations, U-Line continues to be the leader in innovation, quality and value in the premium built-in undercounter ice making, refrigeration and wine preservation market. U-Line has captivated those with an appreciation for the finer things with exceptional functionality, style, inspired innovation and attention to even the smallest details. We are known and respected for our unwavering dedication to product design, quality and selection.

In 1962, Henry Uihlein founded U-Line Corporation as an outgrowth of Ben-Hur Freezer Company and was the first to develop and patent an automatic stand-alone undercounter residential ice maker. His foresight and determination to develop new ideas and to succeed when there were no clear guidelines or solutions are evident today. The newest Uihlein generation continues to build upon the family's innovative legacy at the Milwaukee, Wisconsin based business by providing continuity and vision from which new designs and technology continue to be born.

Today the complete U-Line product collection includes Ice Makers, Wine Captain® Models, Combo® Models, a Refrigerator / Freezer, Refrigerators, Drawers and Beverage Centers. The U-Line brand offers products in the 1000 Series, 2000 Series and the Modular 3000 Series. The 1000 Series offers a more targeted priced product with appropriate features, while the 2000 Series offers upscale features, advanced technology and specialized product families. U-Line's approach to its breadth of products, multiple price points and features allows a choice and product that will fit any lifestyle.

## Read and save this Use and Care Guide.

### NOTICE

**READ all instructions in this guide completely before using the appliance for the first time.**

For future reference, keep this guide in a safe, accessible location. If you need additional information or assistance, please contact U-Line Corporation direct. Contact information appears on the back cover of this guide.

**Before Calling Service.** If you think your U-Line product is malfunctioning, read the OPERATION section of this guide to understand clearly the function of the control. If the problem persists, read the TROUBLESHOOTING GUIDE section of this guide to help you quickly identify common problems, and provide information on possible causes and remedies.

## Please Record Your Model Information

You will need your product model and serial number when you request additional information or services. You can find this information on the serial plate located on the upper right or back wall in the interior of your product. This information also appears on the warranty registration card. Please complete and mail your warranty registration card. You may also register online at [www.u-line.com](http://www.u-line.com)



Please record the model number (1), serial number (2), date of purchase, and dealer contact information for your U-Line product below:

**Model Number:**

---

**Serial Number:**

---

**Purchase Date:**

---

**Dealer Name:**

---

**Dealer Address:**

---

**Dealer Telephone:**

---

## Table of Contents

---

<b>Safety Precautions</b>	
Safety Alert Definitions .....	1
General Precautions .....	1
<b>Product Features</b>	
Combo® Model Features: .....	2
Ice Makers Features: .....	2
<b>Product Operation Touch Control</b>	
Control Systems .....	3
Air Flow .....	3
Initial Startup .....	3
Electronic Control Panel .....	3
Electronic Control Quick Guide .....	5
<b>Product Operation Manual Control</b>	
Air Flow .....	6
Initial Startup .....	6
Control Dial .....	6
Adjusting Air Temperature .....	7
Checking Product Temperature .....	7
<b>Food Storage</b>	
Drawers .....	8
<b>Ice Maker</b>	
Ice Maker Operation .....	9
Ice Maker Adjustment .....	9
<b>Maintenance</b>	
Leveling .....	10
<b>Doors (Self-Closing)</b>	
Door Systems .....	12
Door Alignment and Adjustment .....	12
Reversing Black or White Doors .....	13
<b>Standard Doors</b>	
Door Alignment and Adjustment .....	15
Door Reversability .....	15
Reversing the Door .....	15
<b>Standard Drawers</b>	
Checking Drawer Alignment .....	17
Adjusting Drawer Alignment .....	17
Re-installation of Drawer .....	18
<b>Cleaning</b>	
Exterior Cleaning .....	19
Interior Cleaning .....	19
Defrosting .....	19
Condensor Cleaning .....	20
Storage, Vacation and Moving .....	20
Product Disposal .....	20
<b>Service</b>	
Before Calling for Service .....	21
If Service is Required .....	21
Replacement Parts .....	21
Normal Operating Sounds .....	21
Troubleshooting Guide .....	21

## Safety Precautions

### NOTICE

- **PLEASE READ** all instructions before installing, operating, or servicing the appliance.
- Proper installation procedures must be followed when completing an installation or relocation of a unit. An **INSTALLATION GUIDE** for the unit, providing complete installation information, is available from U-Line Corporation direct. Consult the installation guide before any installation begins. U-Line contact information appears on the rear cover of this guide.
- This unit requires connection to a dedicated 15 Amp grounded (three-prong), polarized receptacle, installed by a qualified electrician, compliant with applicable electrical codes.

## Safety Alert Definitions

Throughout this guide are safety items labeled with a Danger, Warning or Caution based on the risk type:

### DANGER

*Danger means that failure to follow this safety statement will result in severe personal injury or death.*

### WARNING

Warning means that failure to follow this safety statement could result in serious personal injury or death.

### CAUTION

Caution means that failure to follow this safety statement may result in minor or moderate personal injury, property or equipment damage.

## General Precautions

Use this appliance for its intended purpose only. Follow these general precautions with those listed throughout this guide:

### DANGER

**RISK OF CHILD ENTRAPMENT.** Before you throw away your old refrigerator or freezer, take off the doors and leave shelves in place so children may not easily climb inside.

### WARNING

**SHOCK HAZARD - Electrical Grounding Required.**

- Never attempt to repair or perform maintenance on the unit until the electricity has been disconnected.
- Never remove the round grounding prong from the plug and never use a two-prong grounding adapter.
- Altering, cutting of power cord, removal of power cord, removal of power plug, or direct wiring can cause serious injury, fire and or loss of property and/or life, and will void the warranty.
- Never use an extension cord to connect power to the unit.
- Always keep your working area dry.

### WARNING

Install provided Anti-Tip kit. Serious personal injury could occur.

### CAUTION

- Use care when moving and handling the unit. Use gloves to prevent personal injury from sharp edges.
- If your model requires defrosting, **DO NOT** use an ice pick or other sharp instrument to help speed up defrosting. These instruments can puncture the inner lining or damage the cooling unit. **DO NOT** use any type of heater to defrost. Using a heater to speed up defrosting can cause personal injury and damage to the inner lining.

### NOTICE

- Do not lift unit by door handle.
- Never install or operate the unit behind closed doors. Be sure front grille is free of obstruction. Obstructing free airflow can cause the unit to malfunction and will void the warranty.
- Failure to clean the condenser every six months can cause the unit to malfunction. This could void the warranty.
- Do not Block any internal Fans.

Use only genuine U-Line replacement parts. Imitation parts can damage the unit, affect its operation or performance and may void the warranty.

## Product Features

---



### Combo® Model Features:

**Built-in or Freestanding.** Provides custom look when built-in with no additional venting clearance needed on sides, top or rear. Do not obstruct the grille.

**Ice making and refrigeration in one unit.** Provides both ice production and refrigeration in one compact unit.

#### CO2175FF & C2275DWR

**Digital Controls.** Provides ability to set and see the temperature. Manages key model functions and provides user alerts.

**Sabbath or “Black Out” mode.** Easily turn off all lights and control display.

**Contemporary grille design.** Integrates seamlessly into surrounding cabinetry.

**Stainless Steel Models.** Offers a bold, full wrap, stainless steel door.

**Overlay Model.** The C2275DWR includes full overlay drawer capability. Provides a fully integrated appearance with surrounding décor.

**Vinyl clad cabinets.** Black vinyl cabinet on all models provides a rich textured look.

**Leveling Legs.** More precise under counter fit, durable, factory installed.

**Recessed interior lights.** Automatically illuminate when the door is opened.

#### CO29FF

**Two Tempered glass shelves.** Generous amount of shelf space, Easy to clean.

**In door storage.** 3 shelves provide easy access.

**Flat recessed grille.** Blends with and integrates with surrounding cabinetry.

### Ice Makers Features:

**High ice production and storage.** Combo® Models provide both ice production and refrigeration in one compact unit. CO2175FF and CO29FF models produce up to 8 pounds of ice per day and store 13 pounds. C2275DWR models produce up to 6 pounds of ice per day and store 10 pounds. C2275DWR has 3 cubic feet while the CO2175FF has 4.2 cubic feet and the CO29FF has 2.1 cubic feet of refrigeration storage.

**No drain required.** Easy and inexpensive to install. Only requires a 1/4" outside diameter water line.

**Conserves on water.** Uses under 3 gallons of water to produce 22 pounds of ice or 2-1/4 gallons for 18 pounds.

## Product Operation Touch Control

### Control Systems

A portion of models covered in this guide use an electronic touch control while others use a manual control system. See the table below to identify your model and equipped control system. Users with models using manual control should reference “Product Operation Manual Control” on page 6.

Model	Control	Model	Control
U-CO2175FB-00	Electronic	U-CO29FB-99	Manual
U-CO2175FS-00	Electronic	U-CO29FWH-00	Manual
U-CO2175FS-01	Electronic	U-CO29WH-03	Manual
U-CO2175FW-00	Electronic	U-CO29WHTP-20	Manual
U-CO29B-00	Manual	U-C2275DWROL-00	Electronic
U-CO29B-03	Manual	U-C2275DWRS-00	Electronic
U-CO29B-20	Manual	U-2175RFB-00	Electronic
U-CO29BTP-20	Manual	U-2175RFS-00	Electronic
U-CO29FB-00	Manual	U-2175RFS-01	Electronic
U-CO29FB-98	Manual	U-2175RFW-00	Electronic

### Air Flow

#### NOTICE

The unit requires proper air flow to perform at its highest efficiency.

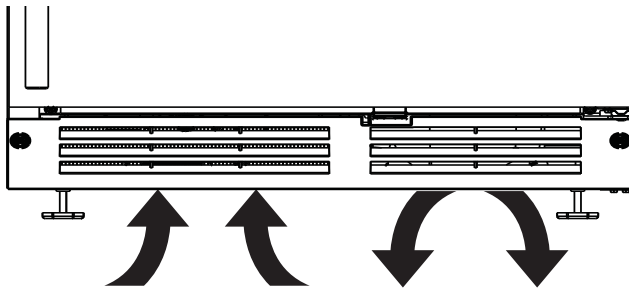

### Initial Startup

All U-Line controls are preset at the factory. Initial startup requires no adjustments.

#### NOTICE

**U-Line recommends allowing the unit to run overnight before loading refrigerator or freezer with product.**

To turn the unit on or off, press and hold POWER  (1) for ten seconds and release. The display will show the unit set point temperature when turned on and display “OFF” when the unit is off.

## Electronic Control Panel

### Digital Display

The electronic control with digital display shows a single continuous set point temperature. This set point is for the middle zone, it is a base number used by the controller to maintain the multiple temperature zones in the unit. The factory default set point for Beverage Center and Refrigerator models is 38°F. The set point temperature is a gauge for further temperature adjustments.



### Adjusting Air Temperature

#### NOTICE

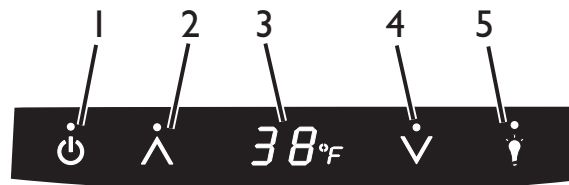

**Adjust the set point temperature in single increments, and wait 24 hours for the temperature to stabilize before rechecking.**



#### To adjust the set point temperature:



1. Press and release either WARMER  (2) or COOLER  (4) to put the controller in the SET TEMPERATURE mode. The display (3) will begin to flash the °F (or °C) symbol.

NOTE: This mode will self-cancel in five seconds, and the display (3) will show the original set-point temperature.

2. Within five seconds (while the °F (or °C) symbol is flashing), press WARMER  or COOLER  as required to adjust the set point temperature.
3. The change is committed 5 seconds after adjusting the temperature, and the display (3) will show the new set point temperature.

**Temperature Selection (°F °C).** U-Line products supplied for 110 VAC have temperatures displayed (3) by default in Fahrenheit (°F). Models supplied for 220 VAC have temperatures displayed (3) by default in Celsius (°C).

Easily adjust the display for either type of temperature display.

1. Press and hold LIGHT  (1) and simultaneously within five seconds press COOLER  (5) three times to change the display (3) as needed.

**Temperature Display.** The digital display shows set-point. Under normal operating conditions the temperatures will fluctuate based on a number of factors including door openings, product load, room temperature, and humidity. On passive cooled units the temperature will always be cool toward the top and coolest toward the bottom.

1. Press WARMER  (2) for five seconds. The display (3) will indicate the actual temperature.
2. After 10 seconds, the set point temperature will return to the display.

## Checking Product Temperature

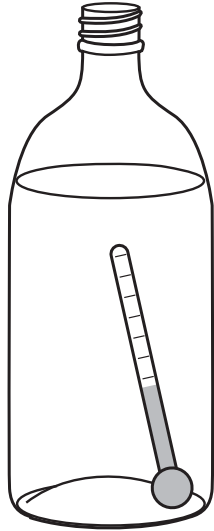

### To check the actual product temperature in the unit.

1. Partially fill a plastic (nonbreakable) bottle with water.
2. Insert an accurate thermometer.
3. Tighten the bottle cap securely.
4. Place the bottle in the desired area for 24 hours.
5. Avoid opening the unit during the testing period.
6. After 24 hours, check the temperature of the water. If required, adjust the temperature control in small increments (See ADJUSTING TEMPERATURE).

### Causes which affect the internal temperatures of the cabinet include:

- Temperature setting.
- Ambient temperature where installed.
- Installation in direct sunlight or near a heat source.
- The number of door openings and the time the door is open.
- The time the internal light is illuminated. (This mainly affects product on the top rack or shelf.)
- The front grille or condenser are obstructed.

## Interior Lighting

**Normal Operation.** Opening the door will cause the interior of the cabinet to illuminate.

Use LIGHT  (5) on the control panel to change the lighting functions.

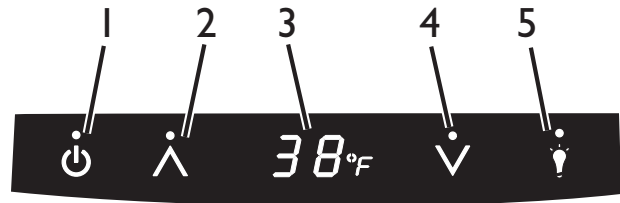















**Blackout (Sabbath) Mode.** The interior of the cabinet and control display remains darkened for a 36-hour period. Blackout (Sabbath) Mode is not Star K certified.

To turn the lights and display OFF for a preset 36-hour interval.

1. Press and hold LIGHT  (5) for ten seconds and release (the °F symbol will flash briefly at the end of the ten second period).
2. The interior light and control display (3) will go dark for the next 36 hours.
3. NOTE: Although the display will not be visible, the temperature controls in the unit remain active, and preserve the interior temperature.

To exit Blackout (Sabbath) Mode before the 36-hour period, repeat Step 1.

## Electronic Control Quick Guide

Task	Touch	Touch	Display	Comment
Turn ON/OFF	 Hold 10 seconds	Release when °F flashes.	 or 	
Adjust Temperature	 or  Touch and release	 or  Touch to change temperature.		°F flashes after first touch, set-point saved after 5 seconds of inactivity and °F stops flashing.
View Actual Temp	 Hold 5 seconds	Release when °F flashes.		WC models will scroll top/mid/bottom temps.
Change F/C	 Hold		 or 	
Blackout Mode	 Hold 10 seconds		Display (and cabinet light) will not operate in Blackout Mode.	Blackout will end in 36 hours, or hold again to terminate early.

**NOTE:** 38°F is an example; the display will vary with actual setpoint.



## Product Operation Manual Control

### Air Flow

#### NOTICE

The unit requires proper air flow to perform at its highest efficiency. Do not block the front grille or internal fans at any time, or the unit will not perform as expected. Do not install the unit behind a door.

CO29FF

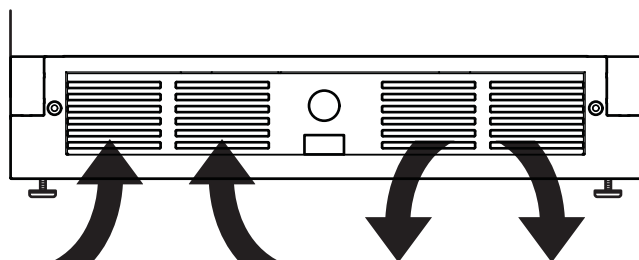

### Initial Startup

All U-Line controls are preset at the factory. Initial startup requires no adjustments.

#### NOTICE

U-Line recommends allowing the unit to run overnight before loading refrigerator or freezer with product.

#### NOTICE

On ice maker equipped units, it is possible that dirt or scale will dislodge in the water line. Always throw away all ice cubes made during the first two to three hours of operation.



#### To turn the unit on or off:

Depending on model, a rocker switch will be located below the temperature control dial in the center of the grille (2), inside the door on the front panel, or behind the grille. To toggle the power state simply switch the rocker from one side to the other.

### Control Dial

Combo Models provide two temperature zones within the cabinet to satisfy the specific storage requirements.

The control dial sets a single continuous temperature. This setpoint temperature is a base setting used by the controller to maintain the temperature zone in the unit. The factory default setting is number 3 or 4. The setpoint temperature is a gauge for further temperature adjustments.

## Adjusting Air Temperature

Combo Models

### NOTICE

- Adjust the set point temperature in single increments, and wait 24 hours for the temperature to stabilize before rechecking.
- Factory recommended set-point is between 3 & 4 on the dial control.

#### To adjust the set point temperature:

Adjust the temperature by turning the numbered dial (1) in small increments.

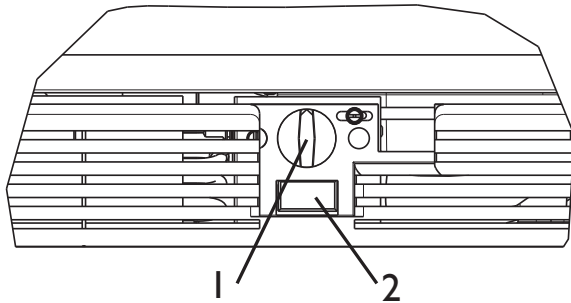

## Checking Product Temperature

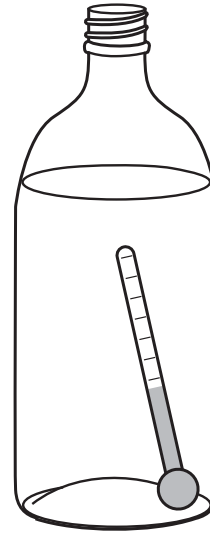

#### To check the actual product temperature in the unit:

1. Partially fill a plastic (nonbreakable) bottle with water.
2. Insert an accurate thermometer.
3. Tighten the bottle cap securely.
4. Place the bottle in the desired area for 24 hours.
5. Avoid opening the unit during the testing period.
6. After 24 hours, check the temperature of the water. If required, adjust the temperature control in a small increment (See ADJUSTING TEMPERATURE).

#### Causes which affect the internal temperatures of the cabinet include:

- Temperature setting.
- Ambient temperature where installed.
- Installation in direct sunlight or near a heat source.
- The number of door openings and the time the door is open.
- The time the internal light is illuminated. (This mainly affects product on the top rack or shelf.)
- The front grille or condenser are obstructed.

## Food Storage

### Drawers

The drawers should only be removed for servicing by a trained and certified repair person.

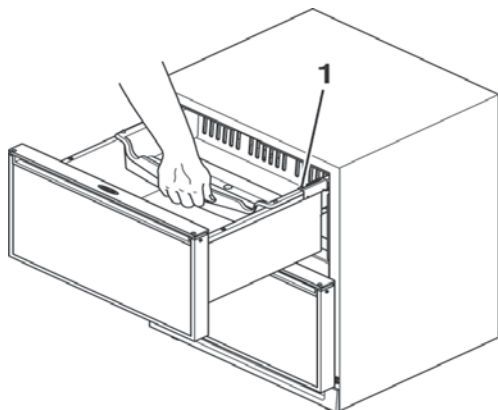

### Top Storage Bin

Grasp the bin handle and slide backward to access the contents below. The bin may be completely removed for cleaning once it is slid forward, making sure it clears the guides on each side of the drawer. Then lift straight up. If heavy items are stored in bin, push front of bin down slightly while sliding. Slide bin forward, especially with heavy items, to ensure that drawer closes completely.

### Crispers

#### **CAUTION**

**When opening or closing the crisper, pull or push slowly and carefully. If the crisper is pulled out too far or pushed in too hard, it could come out all the way and possibly cause product damage or personal injury.**

Your models may have a lower crisper drawer for storage.

To open, grasp the crisper handle and slowly pull out to access the drawer contents. The crisper may be completely removed for cleaning.

If the drawer is pulled out too far, it will come out of the cabinet, and may be damaged by falling.

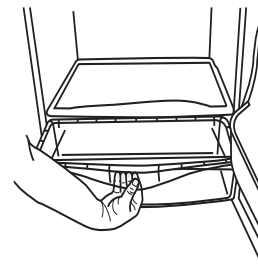

## Ice Maker

### Ice Maker Operation

When the ice bucket is full, the ice making mechanism will shut off. However, the refrigeration system will continue to cool and maintain the ice supply. Frost-free ice maker units have lower ice production than manual defrost units.

#### NOTICE

**Do not place cans or bottles in the ice compartment because they will freeze.**

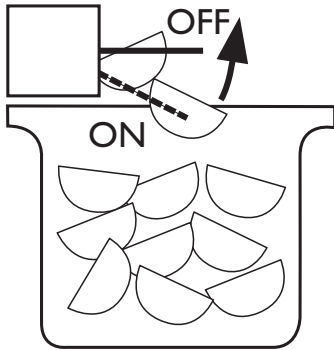

**To turn off ice production:** Raise the bin arm into an upright and locked position. The unit will preserve temperature for ice storage.

#### NOTICE

**If not intending to use the ice maker turn the water supply valve off, it is important to raise the bin arm of the ice maker (Figure 1). Failure to raise the bin arm may result in damage to the water valve.**

Certain sounds are normal during the unit's operation. You may hear the compressor or fan motor, the water valve, or ice dropping into the ice bucket.

#### CAUTION

**NEVER use an ice pick, knife or other sharp instrument to separate cubes. Shake the ice bucket instead.**

During periods of limited use or high ambient temperatures, it is common for cubes to fuse together. Gently shake the bucket to break apart cubes. If not using the ice maker regularly, empty the ice bucket periodically to ensure fresh cubes.

It is normal for cubes to appear cloudy. The cause is air trapped in the water because of fast freezing. It is not caused by the health, taste or chemical make up of the water. It is the same air that is in every glass of water you drink.

Remove the ice bucket for emptying and cleaning. To remove the ice bucket, raise the bin arm and remove the bucket from the ice compartment. Use the ice bucket for ice storage only.

## Ice Maker Adjustment Ice Cube Thickness Adjustment

### Interval - As Required

On ice maker equipped models, adjust the cube size by changing water amount injected into the ice maker assembly as follows:

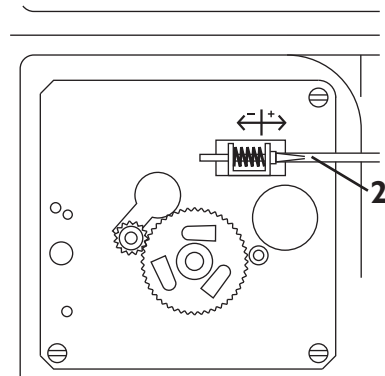
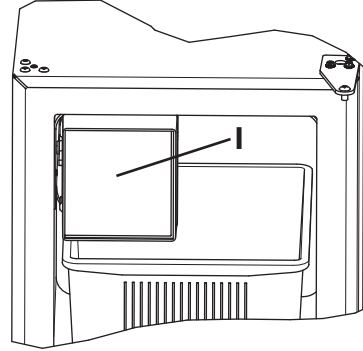

1. Remove the ice maker assembly cover (1).
2. Find the adjusting screw on the ice maker assembly control box (2). The adjusting screw is just below the minus (-) and plus (+) signs on the control box.

#### CAUTION

**Too large of an adjustment to the screw can cause the water to overflow the ice maker and can cause property damage.**

3. Turn the adjusting screw toward the minus (-) sign (clockwise) for smaller cubes or toward the plus (+) sign (counterclockwise) for larger cubes.
4. Install the ice maker assembly cover.

## Maintenance

### Leveling

#### NOTICE

Unit must be level, for proper door and ice maker (if equipped) operation.

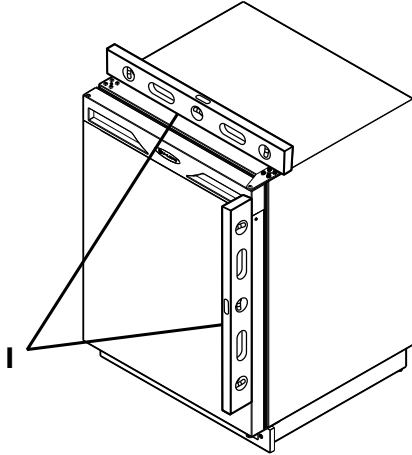

#### For Models with adjustable leveling feet:

1. Use a level to check the levelness of the unit from front to back and from side to side. Place the level along top edge and side edge as shown (1).
2. If the unit is not level, rotate the adjustable leveling legs to raise or lower each corner of the unit as necessary.
3. Check levelness after each adjustment and repeat the previous steps until the unit is level.

#### For Models without adjustable leveling feet:

#### NOTICE

The unit must be located on a level surface, for proper door and ice maker (if equipped) operation.

Use a level to check the levelness of the unit from front to back and from side to side. Place the level along top edge and side edge as shown (1).

## Removing and Installing Interior Shelves

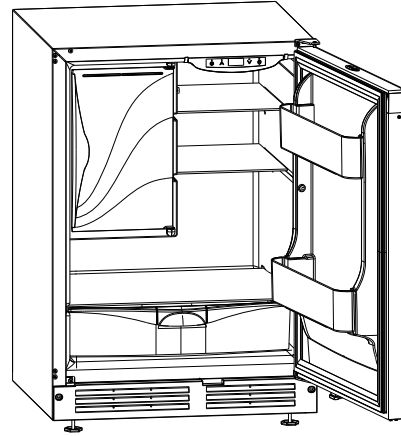

For models equipped with glass shelves having shelf supports, remove the shelves as follows:

1. Open door completely.
2. Grasp the shelf edge in the center and slide the shelf from the unit.

Insert the shelves as follows:

1. Reposition the shelf as required, ensure the raised white edge strip is toward the rear of the unit and graphics, if applied, are on the underside of the shelves.
2. Gently slide the shelf back in to the cabinet at the desired position.

## Removing and Installing Grille

### **WARNING**

Disconnect electric power to the unit before removing the grille.

### **WARNING**

**DO NOT** touch the condenser fins (4). The condenser fins are **SHARP** and can be easily damaged.

#### Removing the grille.

1. Disconnect power to the unit.
2. Remove control knob (6) if equipped.
3. Loosen the two screws (1). Some models may have only one screw in the center.
4. Remove grille (2) and grille cap (if equipped) (3) from unit.

#### Installing the grille:

1. For 15 and 29 models make sure grille cap (3) is behind grille in slots provided in grille before attaching grille to unit.
2. For 75 models place the hook-hinge located on the rear bottom side of the grille (2) onto the front lip of the unit base. Swing the grille up into position.
3. Align cabinet and grill holes and secure, but do not overtighten grille screws (1).
4. Install control knob (6) if equipped.
5. Reconnect power to the unit.

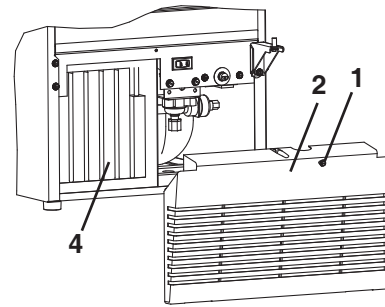
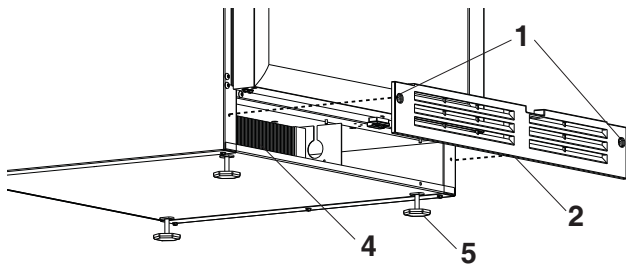
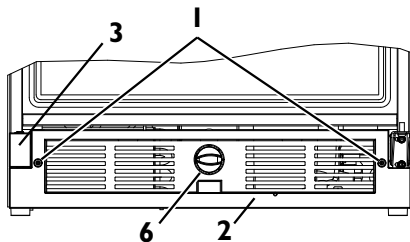

## Removing and Installing Door Shelves

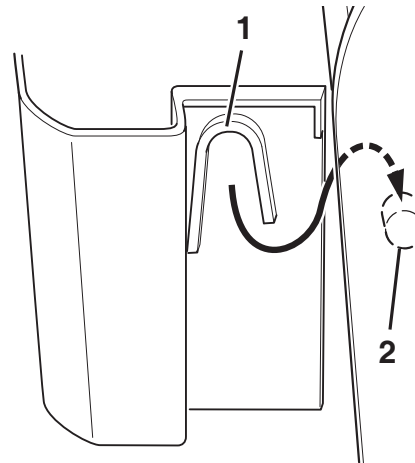

For models equipped with door shelves:

To remove the door shelf:

1. Grasp shelf in center, and lift until the shelf notches (1) clear the pins (2).
2. Carefully pull the shelf away from the door.

To install the door shelf:

1. Holding the shelf in the center, center the shelf in the door at the desired location, slightly above the pins (2).
2. Lower the shelf onto the pins (2).

## Doors (Self-Closing)

### Door Systems

A portion of models covered in this guide use the “Self-Closing” door system while others use the standard door system. See the table below to help identify which door system your model is equipped with. Standard doors should reference “Standard Doors” on page 15. Units equipped with drawers should reference “Standard Drawers” on page 17.

Model	Door Type	Model	Door Type
U-CO2175FB-00	Self-Closing	U-CO29FB-99	Standard
U-CO2175FS-00	Self-Closing	U-CO29FWH-00	Standard
U-CO2175FS-01	Self-Closing	U-CO29WH-03	Standard
U-CO2175FW-00	Self-Closing	U-CO29WHTP-20	Standard
U-CO29B-00	Standard	U-C2275DWROL-00	Drawer
U-CO29B-03	Standard	U-C2275DWRS-00	Drawer
U-CO29B-20	Standard	U-2175RFB-00	Self-Closing
U-CO29BTP-20	Standard	U-2175RFS-00	Self-Closing
U-CO29FB-00	Standard	U-2175RFS-01	Self-Closing
U-CO29FB-98	Standard	U-2175RFV-00	Self-Closing

### Door Alignment and Adjustment

Align and adjust the door if it is not level, or is not sealing properly. If the door is not sealed the unit may not cool properly, or excessive frost may form in the interior.

#### NOTICE

- Properly aligned, the door’s gasket should be firmly in contact with the cabinet all the way around the door (no gaps). Carefully examine the door’s gasket to ensure that it is firmly in contact with the cabinet. Also make sure the door gasket is not pinched on the hinge side of the door.
- The door will not be flush with the top of the cabinet. The top edge of the door will be 1/8 in. (3.175 mm) below the cabinet top.

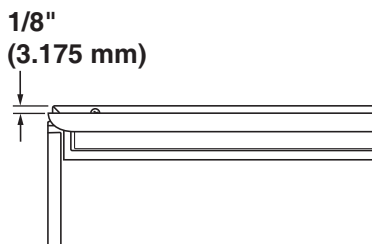

#### To align and adjust the door:

1. Compare the top edge of the door (opposite the hinges) to the top edge of the cabinet and note the type (up or down) of adjustment needed.

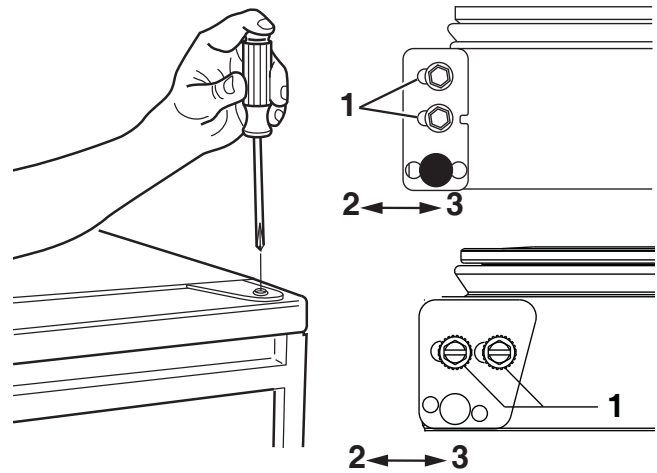

2. Remove the top hinge pivot pin with a Phillips screwdriver and lift door off bottom hinge pin. Be careful not to lose the door closer insert sets.
3. Turn the door upside down and inspect the hinge plate mounting holes. The plate has slotted mounting holes. Loosen but do not remove the two hinge plate screws (1).
4. If door edge opposite the hinges needs to move up, move plate toward outside of door (2). If door edge needs to move down, move plate toward inside of door (3). Repeat until top edge of door is parallel with top of cabinet and tighten screws (1) securely.

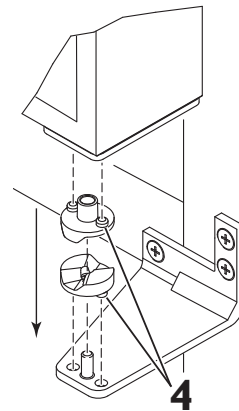

5. After adjustment is complete, remove the door closers from the bottom hinge, clean thoroughly and apply petroleum jelly to the mating surfaces of the closers. Be sure that pins on closers align with holes in the door and bottom cabinet hinge plates. Mount door and install top hinge pivot pin.

## Door Reversability

Location of the unit may make it desirable to mount the door on the opposite side of the cabinet. Many doors are reversible. See table below.

Model	Reverse	Model	Reverse
U-2175RFB-00	YES	U-CO2175FB-00	YES
U-2175RFS-00	NO	U-CO2175FS-00	NO
U-2175RFS-01	NO	U-CO2175FS-01	NO
U-2175RFW-00	YES	U-CO2175FW-00	YES

## Reversing Black or White Doors

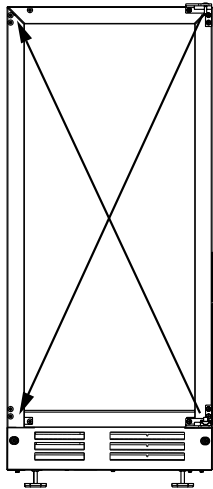

- The hinge hardware will be removed and reinstalled on the opposite side of the cabinet.
- The top hinge hardware will be reinstalled on the bottom of the opposite side of the cabinet.
- The bottom hinge hardware will be reinstalled on the top of the opposite side of the cabinet.

### Remove Door

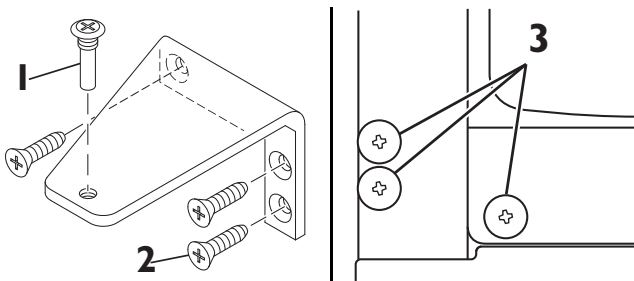

1. Hold door to keep it from falling.
2. Remove hinge screw pin (1) from top hinge using a Phillips screwdriver.
3. Remove door by tilting forward and lifting door off bottom hinge closer inserts.
4. Reinstall hinge screw pin (1) into top hinge using a Phillips screwdriver.

### Remove hole plugs.

Remove plastic screw plugs (three each, top and bottom) (3) from new hinge location. Save for reinstallation later.

### Remove existing top hinge.

Remove existing top hinge (three screws) (2).

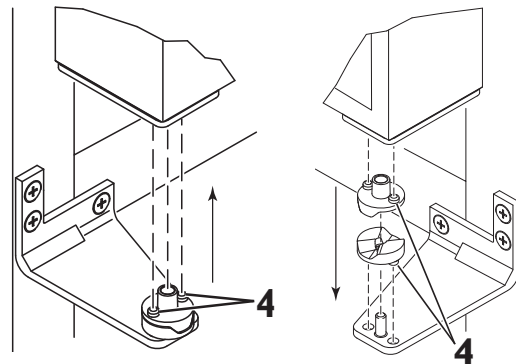

### Reinstall hinge to bottom opposite.

1. Install the hinge just removed from the top to the **BOTTOM** opposite side of the cabinet (three screws) (2).
2. Remove the two door closer inserts (4) from the existing bottom hinge.
3. Install door closer inserts as shown on the new bottom hinge (4).

### Remove preexisting bottom hinge.

1. Remove the preexisting bottom hinge (three screws) (2).

### Reinstall hinge to top opposite.

1. Install the hinge just removed from the bottom to the **TOP** opposite side of the cabinet (three screws) (2).

### Reinstall Hole Plugs.

1. Install plastic screw plugs (three each, top and bottom) (3) into holes where hinge hardware was removed.

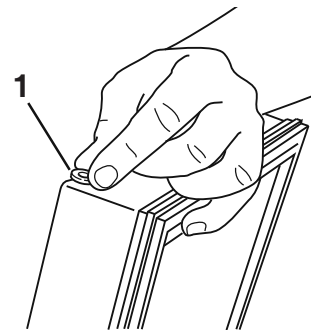



**Prepare door for reinstallation.**

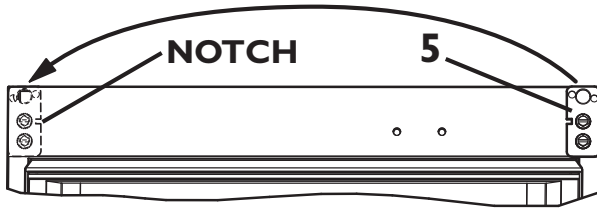

1. Remove plastic hole plug from top of door handle and reinstall on opposite side.
2. With bottom of door facing up, remove pivot plate (5) (two screws).
3. Flip over and install pivot plate on opposite side of door. Ensure notch in plate faces center.

**Install Door.**

1. Hold door upright and tilted forward.
2. Lift door on to bottom hinge closer inserts.
3. Tilt door forward into position.
4. Hold door to keep it from falling.
5. Reinstall hinge screw pin (1) into top hinge using a Phillips screwdriver.

**Align and adjust the door:**

Align and adjust the door, see DOOR ALIGNMENT AND ADJUSTMENT on page 12.

## Standard Doors

### Door Alignment and Adjustment

Align and adjust the door if it is not level, or is not sealing properly. If the door is not sealed the unit may not cool properly, or excessive frost may form in the interior.

#### NOTICE

Properly aligned, the door's gasket should be firmly in contact with the cabinet all the way around the door (no gaps). Carefully examine the door's gasket to ensure that it is firmly in contact with the cabinet. Also make sure the door gasket is not pinched on the hinge side of the door.

#### To align and adjust the door:

1. Loosen (do not remove) top and bottom hinge screws.
2. Align door squarely with cabinet.
3. Make sure gasket is firmly in contact with cabinet all the way around the door (no gaps).
4. Tighten bottom hinge screws.
5. Tighten top hinge screws.

### Door Reversability

Location of the unit may make it desirable to mount the door on the opposite side of the cabinet.

Models with black and white doors are field-reversible.

Stainless steel models with glass doors without locks are field-reversible.

Stainless steel models without glass doors must be ordered right- or left-hand hinged.

### Reversing the Door

The hinge hardware will be removed and reinstalled on the opposite side of the cabinet.

The hinge plate is flipped over when it is reinstalled on the opposite side of the cabinet.

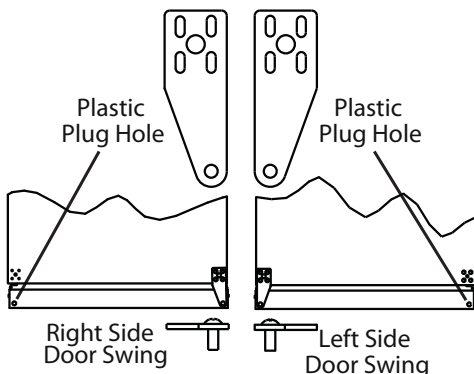

#### To reverse the door:

##### Remove grille:

Remove the grille, see MAINTENANCE section of this guide.

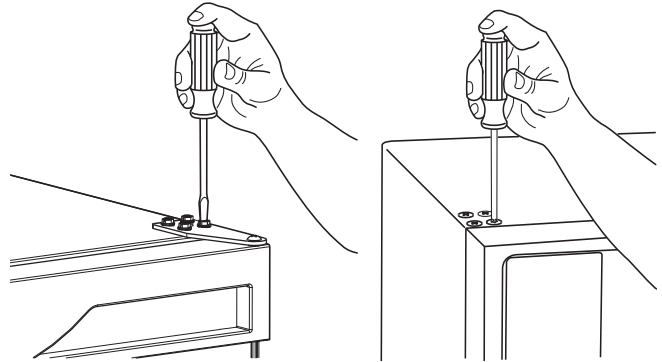

##### Remove top hinge, and door:

1. Hold door to keep it from falling.
2. Remove top hinge from cabinet by removing three or four screws, depending on model.
3. Remove door by tilting forward and lifting door off bottom hinge.
4. Remove three or four plastic screw plugs from hinge holes on the opposite side. Reinstall into holes where the hinge was removed. Ensure not to scratch cabinet.

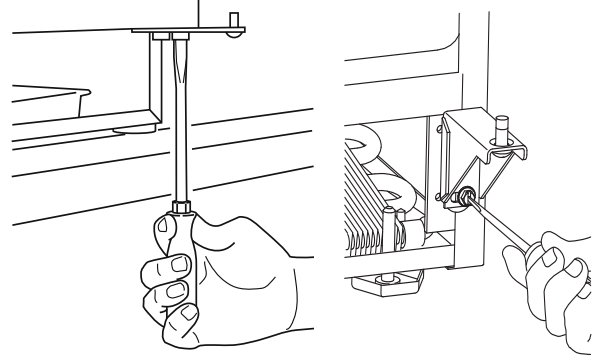

##### Remove bottom hinge:

1. Remove bottom hinge from cabinet. Some models will have a gusset with two screws. Other models will have a plate with three screws.
2. Remove corresponding screws on opposite side of cabinet. On some models there may be a nut behind one or both screws on either side.

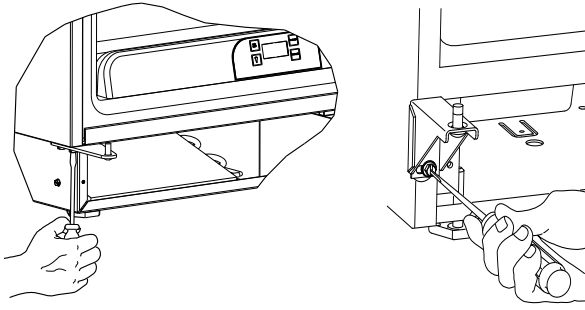

**Install bottom hinge:**

1. If you have a plate hinge, reorient the pivot screw so it protrudes the opposite direction from the hinge. Remove the pivot screw from the hinge. Turn the plate over and reinstall the screw.
2. Align hinge outer edge with cabinet. For models with a plate hinge, the flat edge of the hinge aligns with the outer edge of the cabinet.

Install two or three screws, depending on model. Replace nuts if used.

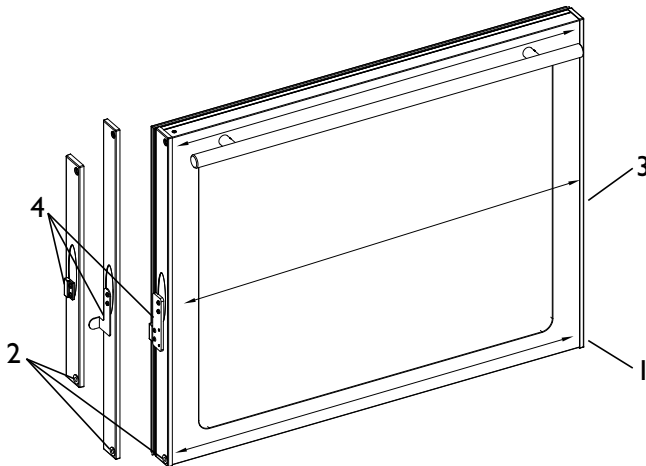

**Prepare door for reinstallation:**

**For stainless steel models with glass doors:**

1. Stainless glass doors are flipped upside down to be reversed.
2. Lay the door on it's side. Remove the plastic hole plug (1) and install in the corner opposite of where it was removed.
3. Remove the plastic hinge bushing (2) and install in the corner opposite of where it was removed.
4. Remove the U-Line nameplate (3) from door. This will reveal mounting holes for the door actuator bracket.
5. Remove door actuator (4) from door. Be sure to only remove the two screws holding the actuator to the door. Reinstall the actuator (4) on the opposite end of the door where the nameplate was removed.
6. Install new nameplate where the actuator assembly was removed.

7. Install screws into holes on opposite side, where the hinge was removed. Replace nuts if used.

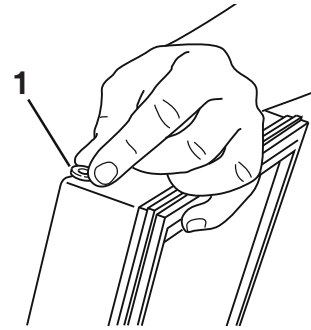

**Prepare door for reinstallation:**

**For black or white doors:**

1. Remove plastic hole plug from top of door handle and reinstall on opposite side.
2. Remove plastic hinge bushing on bottom of door and reinstall on opposite side. Clean out bushing hole in door bottom with a screwdriver if necessary.

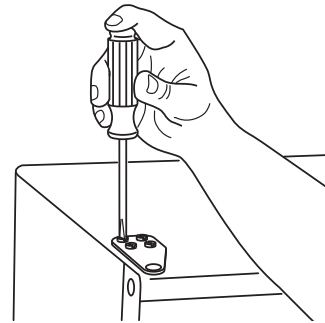

**Install top hinge, and door:**

1. Reorient the pivot screw so it protrudes the opposite direction from the hinge. Remove the pivot screw from the hinge. Turn the plate over and reinstall the screw.
2. Hold door to keep it from falling.
3. Lift the door on to the bottom hinge.
4. Align flat edge of the hinge with the outer edge of the unit.
5. Install three or four screws, depending on model.

**Align and adjust the door:**

1. Align and adjust the door, see DOOR ALIGNMENT AND ADJUSTMENT.

**Install grille:**

Install the grille, see MAINTENANCE section of this guide.

## Standard Drawers

### Checking Drawer Alignment

The unit's drawers are aligned at the factory before shipment. However, their alignment could have been disturbed during shipment or during overlay panel installation. Check each drawer to confirm that it is aligned:

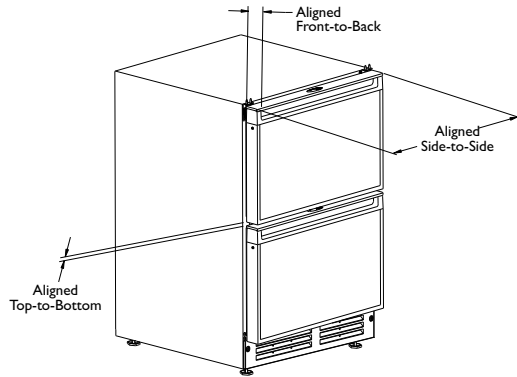

- **Side-to-Side** — When viewed from the top, the drawer front should be square with the sides of the cabinet.
- **Front-to-Back** — When viewed from the side, the drawer front should be straight with the cabinet's sides, not cocked forward or back.
- **Top-to-Bottom** — When viewed from the front, the drawer should be level horizontally.

### Adjusting Drawer Alignment

#### **WARNING**

**SHOCK HAZARD** — The unit must be unplugged from the wall outlet during drawer removal, adjustment and re-installation.

#### Drawer Removal:

1. Confirm that the unit is unplugged from wall outlet.
2. Unplug the drawer's connection wiring (top drawer only).
3. Remove the mounting screws.
4. Pull the drawer completely out of the unit.

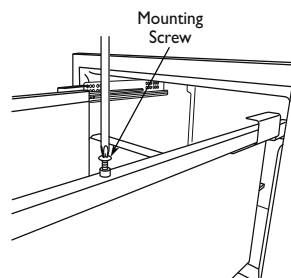

#### **CAUTION**

Use care when handling the drawer. Drawer edges, drawer rail and the unit's slide may be sharp.

## NOTICE

Drawer adjustments are made by moving the slide that carries the drawer's rail. Minor adjustments may be made by loosening one of the slide's mounting screws, adjusting the slide and retightening the screw. Severe adjustments may be made by removing the slides' mounting screws, drilling new mounting holes and remounting the slide.

#### Side-to-Side Adjustment:

The drawer will need a Side-to-Side Adjustment if, when viewed from the top, the drawer front is not square with the sides of the cabinet. This is caused by one of the slides being mounted too far forward on the unit's liner.

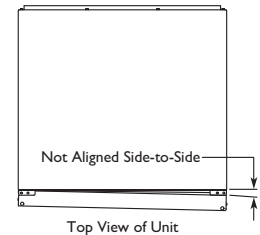

#### Minor Adjustment:

*Note:* The mounting holes on the slide are slightly larger than the screws' diameter.

1. Loosen the slide's mounting screws.
2. Push the slide backward.
3. Retighten the screws.

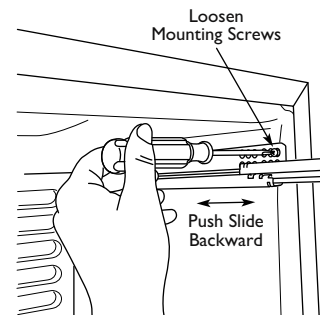

#### Severe Adjustment:

*Note:* The slides have extra mounting holes that may be used.

1. Remove the slide's mounting screws.
2. Reposition the slide so it is the same distance from the front of the liner as the other slide. Measure to confirm.
3. Mark new drilling holes using different sets of mounting holes on the slide.

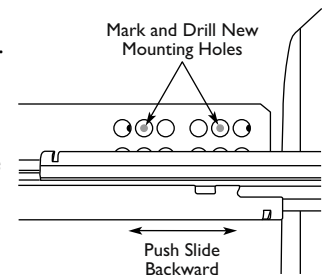

*Note:* Front location holes are shown. Corresponding rear holes will also need to be marked.

4. Drill all the new holes with a #30 drill bit.
5. Remount the slide.

#### Front-to-Back Adjustment:

The drawer will need a Front-to-Back Adjustment if, when viewed from the side, the drawer front is cocked forward or back. This is caused by the front slide mountings not being level with the rear slide mountings.

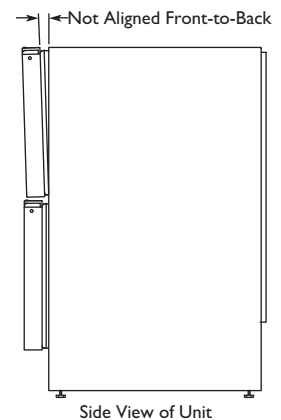

### Minor Adjustment:

Note: The mounting holes on the slide are slightly larger than the screws' diameter.

1. Loosen one slide's mounting screws.
2. Level the slide.
3. Retighten the screws.
4. Repeat procedure for the other slide.

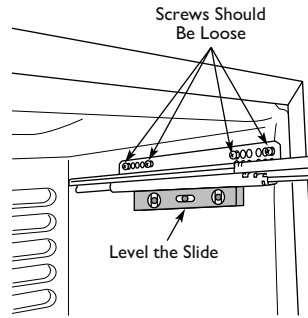

### Minor Adjustment:

Note: The mounting holes on the slide are slightly larger than the screws' diameter.

1. Loosen one slide's mounting screws.
2. Push the slide upward or downward to match the position of the other slide.
3. Retighten the screws.
4. Repeat the procedure with the other slide if necessary.

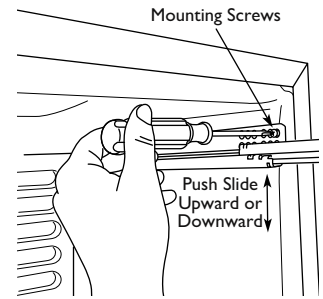

### Severe Adjustment:

Note: The slides have extra mounting holes that may be used.

1. Loosen one slide's rear mounting screws.
2. Remove the slide's front mounting screws.
3. Reposition the slide so it is level.
4. Mark new front drilling holes using a different set of mounting holes on the slide.
5. Drill the new holes with a #30 drill bit.
6. Remount the slide.
7. Repeat procedure for the other slide.

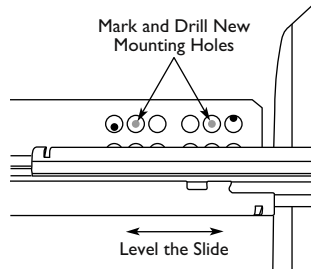

### Severe Adjustment:

Note: The slides have extra mounting holes that may be used.

1. Remove one slide's mounting screws.
2. Reposition the slide so it is the same distance from the bottom of the liner as the other slide. Measure to confirm.
3. Mark new drilling holes using different sets of mounting holes on the slide.

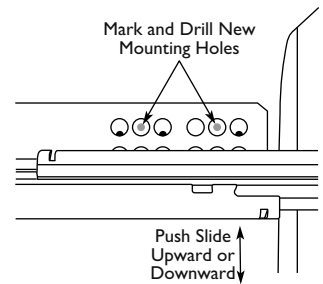

Note: Front location holes are shown. Corresponding rear holes will also need to be marked.

4. Drill all the new holes with a #30 drill bit.
5. Remount the slide.

### Top-to-Bottom (and Left-to-Right) Adjustment:

The drawer will need a Top-to-Bottom Adjustment if, when viewed from the front, the drawer is not level horizontally. Viewed from the top, one side will protrude. This is caused by one of the slides being mounted higher than the other slide on the unit's liner.

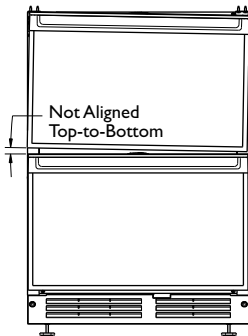

Front View of Unit

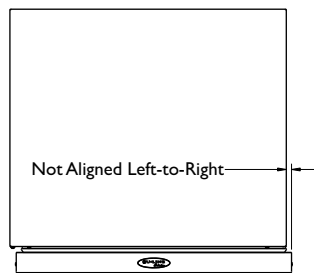

Top View of Unit

### Re-installation of Drawer



Use care when handling the drawer. Drawer edges, drawer rail and the unit's slide may be sharp.

1. Set the drawer's rails onto the slides.
2. Re-install the rails' mounting screws.
3. Plug in the drawer's connection wiring (top drawer only).

## Cleaning

### Exterior Cleaning

#### Vinyl Clad (Black or White) Models:

- Clean surfaces with a mild detergent and warm water solution. Do not use solvent-based or abrasive cleaners. Use a soft sponge and rinse with clean water. Wipe with a soft, clean towel to prevent water spotting.
- Clean any glass surfaces with a non-chlorine glass cleaner.

#### Stainless Models:

- Stainless door panels, handles and frames can discolor when exposed to chlorine gas, pool chemicals, saltwater or cleaners with bleach.
- Keep your stainless unit looking new by cleaning with a good quality all-in-one stainless steel cleaner polish monthly. For best results use Claire® Stainless Steel Polish and Cleaner, which can be purchased from U-Line Corporation (Part Number 173348). Comparable products are acceptable. Frequent cleaning will remove surface contamination that could lead to rust. Some installations may require cleaning weekly.
- **Do not clean with steel wool pads.**
- **Do not use stainless steel cleaners or polishes on any glass surfaces.**
- Clean any glass surfaces with a non-chlorine glass cleaner.
- **Do not use cleaners not specifically intended for stainless steel on stainless surfaces, this includes glass, tile and counter cleaners.**
- If any surface discoloring or rusting appears, clean it quickly with Bon-Ami® or Barkeepers Friend Cleanser® and a nonabrasive cloth. Always clean towards the grain. Always finish with Claire Stainless Steel Polish and Cleaner or comparable product to prevent further problems.
- **Using abrasive pads such as ScotchBrite™ will cause the graining in the stainless to become blurred.**
- Rust not cleaned up promptly can penetrate the surface of the stainless steel and complete removal of the rust may not be possible.

### Interior Cleaning

- **Disconnect power to the unit.**
- Clean the interior and all removed components using a mild nonabrasive detergent and warm water solution applied with a soft sponge or non-abrasive cloth.
- Rinse the interior using a soft sponge and clean water.
- **Do not use any solvent-based or abrasive cleaners.** These types of cleaners may transfer taste to the interior products and damage or discolor the interior.

### Defrosting

#### Automatic Defrost Models

Frost on the rear wall is normal and will melt during each off cycle. If there is excessive build-up of 1/4" or more, manually defrost the unit.

- Ensure the door is closing and sealing properly.
- High ambient temperature and excessive humidity can also produce frost.

#### **CAUTION**

**DO NOT use an ice pick or other sharp instrument to help speed up defrosting. These instruments can puncture the inner lining or damage the cooling unit. DO NOT use any type of heater to defrost. Using a heater to speed up defrosting can cause personal injury and damage to the inner lining.**

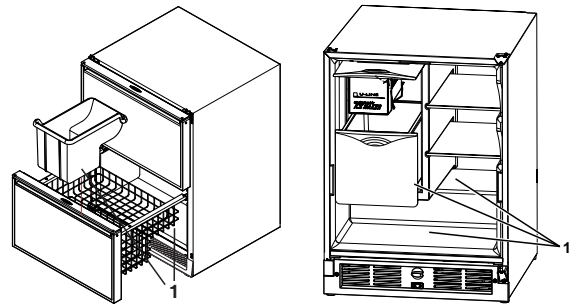

#### To defrost:

1. **Disconnect power to the unit.**
2. For combo models remove all products from the interior.
3. Remove ice bucket and discard ice.
4. Place towel or other absorbent material on bottom of ice bin. For combo models, also place in bottom of unit.
5. Fill the ice bucket half full with warm, not hot water. This will help the unit defrost faster.
6. Place the ice bucket back into the unit on top of the towel or other absorbent material.
7. Prop the door in an open position (2 in. [5 cm] minimum).
8. After about 1 hour remove the ice bin and discard water.
9. Allow the frost to melt naturally.
10. After the frost melts completely clean the interior and all removed components. (See INTERIOR CLEANING)

#### **NOTICE**

**DO NOT clean ice bucket using a dishwasher. The bucket is not dishwasher safe and will be damaged.**

11. When the interior is dry, reconnect power and turn unit on.

**NOTE:** To safeguard against contaminants in ice, discard first three batches of ice after defrosting.

## Condenser Cleaning

### Interval - Every Three Months

To maintain operational efficiency, keep the front grille free of dust and lint, and clean the condenser every three months. Depending on environmental conditions, more or less frequent cleaning may be necessary.

#### **WARNING**

Disconnect electric power to the unit before cleaning the condenser.

#### **WARNING**

DO NOT touch the condenser fins. The condenser fins are SHARP and can be easily damaged.

#### **NOTICE**

DO NOT use any type of cleaner on the condenser unit.

1. Remove the grill. (See MAINTENANCE)
2. Clean the condenser coil (4) using a using a soft brush with a “combing” action or vacuum cleaner. Do not touch the condenser coil.
3. Install the grill. (See MAINTENANCE)

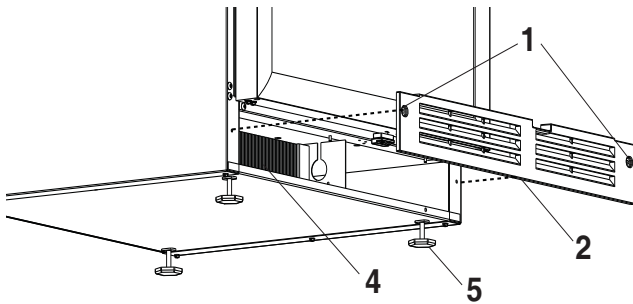

75 Models  
Typical Model Shown

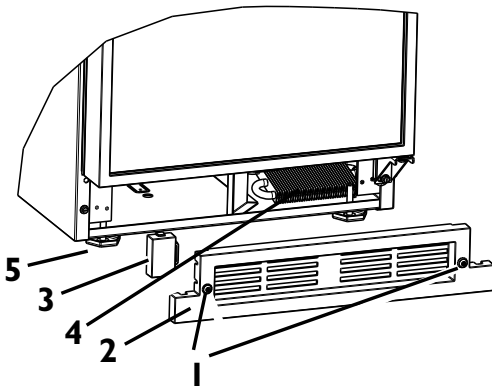

29 Models  
Typical Model Shown

## Storage, Vacation and Moving

If not using the unit for an extended period, or otherwise stored, follow these steps completely:

#### **WARNING**

Electrical Shock Hazard. Disconnect power before servicing. Before operating, replace all panels. Failure to do so may result in death or electrical shock.

#### **NOTICE**

If the ambient temperature is expected to drop below 50°F, turn off and unplug unit, and drain all water from the unit to prevent freezing damage not covered by the warranty.

1. Remove all consumable contents from the unit.
2. Disconnect the power cord from its outlet, and leave it disconnected until the unit is returned to service.
3. Clean and dry the interior of the cabinet.
4. During periods of nonuse, the cabinet must remain open to prevent formation of mold and mildew. Open door a minimum of 2 in. (5 cm) to provide the necessary ventilation.

## Product Disposal

If the unit is being removed from service for disposal, check and obey all Federal, State and or Local regulations regarding the disposal and recycling of refrigeration appliances, and follow these steps completely:

1. Remove all consumable contents from the unit.
2. Disconnect power to the unit and unplug the power cord from its outlet.

#### **DANGER**

RISK OF CHILD ENTRAPMENT. Before you throw away your old refrigerator or freezer, take off the doors and leave shelves in place so children may not easily climb inside.

3. Remove the cabinet door.



## Service

### Before Calling for Service

If you think your U-Line product is malfunctioning, read the OPERATION section of this guide to clearly understand the function of the control.

If the problem persists, read the NORMAL OPERATING SOUNDS and TROUBLESHOOTING GUIDE section of this guide to help you quickly identify common problems, and possible causes and remedies. Most often, this will resolve the problem without the need to call for service.

### If Service is Required

If you do not understand a troubleshooting remedy, or your product needs service, contact U-Line Corporation directly. Contact information appears on the rear cover of this guide.

When you call, you will need your product Model and Serial Numbers. This information can be recorded inside the front cover of this guide. It also appears on the Model and Serial number plate located on the upper right or rear wall of the interior of your product.

### Replacement Parts

When you need replacement parts, always request genuine U-Line replacements. U-Line designs and engineers products using components that work efficiently, and provide superior service life and performance. The use of aftermarket parts or components may affect the safety, operation, performance or durability of your product, and may also void its warranty.

### Normal Operating Sounds

All models incorporate rigid foam insulated cabinets to provide high thermal efficiency and maximum sound reduction for its internal working components. Despite this technology, your model may make sounds that are unfamiliar.

Normal operating sounds may be more noticeable because of the unit's environment. Hard surfaces such as cabinets, wood, vinyl or tiled floors and paneled walls have a tendency to reflect normal appliance operating noises.

Listed below are common refrigeration components with brief description of the normal operating sounds they make. NOTE: Your product may not contain all the components listed.

- Compressor: The compressor makes a hum or pulsing sound that may be heard when it operates.
- Evaporator: Refrigerant flowing through an evaporator may sound like boiling liquid.
- Condenser Fan: Air moving through a condenser may be heard.
- Automatic Defrost Drain Pan: Water may be heard dripping or running into the drain pan when the unit is in the defrost cycle.

## Troubleshooting Guide

### DANGER

**ELECTROCUTION HAZARD.** Never attempt to repair or perform maintenance on the unit until disconnecting the main electrical power.

**Troubleshooting** - What to check when problems occur:

Problem	Possible Cause and Remedy
Interior Light Does Not Illuminate.	The light bulb may be defective. (See MAINTENANCE)
Light Remains on When Door is Closed.	Adjust light actuator bracket on bottom of door.
Unit Develops Frost on Internal Surfaces.	If unit is a manual defrost model it will require occasional defrosting. When there is build-up of 1/4" or more, manually defrost the unit. Ensure the door is closing and sealing properly. High ambient temperature and excessive humidity can also produce frost.
Unit Develops Condensation on External surfaces	The unit is exposed to excessive humidity, moisture will dissipate as humidity levels decrease.
Product is Freezing in Combo Models.	Adjust the temperature to a warmer set-point. (See OPERATION)
Product is Not Cold Enough in Combo Models.	Air temperature does not indicate product temperature. See OPERATION - Checking Product Temperature. Adjust the temperate to a cooler set-point. (See OPERATION) Ensure unit is not located in excessive ambient temperatures or in direct sunlight. Ensure the door is closing and sealing properly. Ensure the interior light has not remained on too long. Ensure nothing is blocking the front grille, found at the bottom of the unit. Ensure the condenser coil is clean and free of any dirt or lint build-up.
Ice Cubes Sticking Together	During periods of limited use or high ambient temperatures, it is common for cubes to fuse together. Gently shake the bucket to break apart cubes.
No Ice Production	Ensure the bin arm is not in the up (off) position.
Not Enough Ice	Ensure the condenser coil is clean and free of any dirt or lint build-up.
Water in Bucket	Ensure cube size adjustment is not set too high.



## PRODUCT INFORMATION

Complete Installation Guides, Use and Care Guides, Specifications & Features and Benefits, CAD Drawings, Overlay Panel/Frame and Toe-Kick Specifications and Instructions, Compliance Documentation and Applicable Energy Guides are available for reference and download at [u-line.com](http://u-line.com).

## SERVICE INFORMATION

Please consult your Use and Care Guide for troubleshooting information. Answers to Customer Frequently Asked Questions are available at [u-line.com](http://u-line.com) under Customer Service. You may contact U-Line directly:

### GENERAL INQUIRIES:

U-Line Corporation  
P.O. Box 245040  
Milwaukee, Wisconsin 53224-9540 U.S.A.  
Phone 1-414-354-0300  
FAX 1-414-354-7905  
Email: [sales@u-line.com](mailto:sales@u-line.com)  
[u-line.com](http://u-line.com)

### SERVICE ASSISTANCE:

Phone 1-800-779-2547  
FAX 1-414-354-5696  
Email: [onlineservice@u-line.com](mailto:onlineservice@u-line.com)  
[u-lineservice.com](http://u-lineservice.com)

### PARTS ASSISTANCE:

E-mail: [onlineparts@u-line.com](mailto:onlineparts@u-line.com)

---

## BUILDING ON THREE GENERATIONS OF INNOVATION

For over five decades and through three generations, U-Line continues to be the leader in innovation, quality and performance in the premium built-in undercounter ice making, refrigeration and wine preservation market. U-Line has captivated those with an appreciation for the finer things with exceptional functionality, style, inspired innovation and attention to even the smallest details. We are known and respected for our unwavering dedication to product design, quality and selection.

In 1962, Henry Uihlein founded U-Line Corporation as an outgrowth of Ben-Hur Freezer Company and was the first to develop and patent an automatic stand-alone undercounter residential ice maker. His foresight and determination to develop new ideas and to succeed when there were no clear guidelines or solutions are evident today. The newest Uihlein generation continues to build upon the family's innovative legacy at the Milwaukee, Wisconsin based business by providing continuity and vision from which new designs and technology continue to be born.

Today the complete U-Line product collection includes Ice Makers, Ice Machines, Wine Captain<sup>®</sup> Models, Combo<sup>®</sup> Models, Refrigerator / Freezers, Refrigerators, Drawer Models and Beverage Centers. The U-Line brand offers products in the 1000 Series, 2000 Series and the Modular 3000 Series. The 1000 Series offers a more targeted priced product with appropriate features, while the 2000 Series offers upscale features, advanced technology and specialized product families. Our Modular 3000 Series provides sleek design and versatile temperature settings with our U-Select<sup>®</sup> control. U-Line's approach to its breadth of products, multiple price points and features allows a choice and product that will fit any lifestyle.

## DESIGNED, ENGINEERED AND ASSEMBLED IN WISCONSIN, USA