

# STANLEY

®

# HD08

## HYDRAULIC HAMMER DRILL

### **⚠ WARNING**

SERIOUS INJURY OR DEATH  
COULD RESULT FROM IM-  
PROPER REPAIR OR SERVICE  
OF THIS TOOL.

REPAIRS AND/OR SERVICE  
TO THIS TOOL MUST ONLY  
BE DONE BY AN AUTHORIZED  
AND CERTIFIED DEALER.



### **⚠ WARNING**

To avoid serious injury or death



Read the Manual



Wear Eye  
Protection



Wear Ear  
Protection



Wear Dust Mask

47351

## SAFETY, OPERATION AND MAINTENANCE SERVICE MANUAL



© Stanley Hydraulic Tools 2004  
OPS/MAINT USA  
Printed in U.S.A.  
17487 9/2005 ver 3

**Stanley Hydraulic Tools**  
3810 SE Naef Road  
Milwaukie OR 97267-5698  
503-659-5660  
FAX 503-652-1780  
[www.stanley-hydraulic-tools.com](http://www.stanley-hydraulic-tools.com)

---

---

---

# TABLE OF CONTENTS

---

CERTIFICATE OF CONFORMITY.....	4
SAFETY SYMBOLS.....	5
SAFETY PRECAUTIONS.....	6
TOOL STICKERS & TAGS.....	7
HYDRAULIC HOSE REQUIREMENTS.....	8
HTMA REQUIREMENTS.....	9
OPERATION.....	10
PREOPERATION PROCEDURES.....	10
CHECK POWER SOURCE.....	10
CHECK THE TOOL.....	10
CONNECT HOSES.....	10
DETERMINE TOOL MODEL.....	10
FORWARD/REVERSE.....	10
HAMMER DRILL OR DRILL ONLY.....	11
BIT INSTALLATION.....	11
DRILL OPERATION.....	12
MODES OF OPERATION.....	12
DRILLING (NON-PERCUSSION).....	12
HAMMER DRILLING (PERCUSSION).....	12
CHISELLING.....	12
TOOL EQUIPMENT & CARE.....	14
TROUBLESHOOTING.....	15
SPECIFICATIONS.....	17
ACCESSORIES.....	17
SERVICE PARTS.....	17
SERVICE.....	18
PARTS ILLUSTRATION.....	24
PARTS LIST.....	25
WARRANTY.....	26

**SERVICING THE STANLEY HYDRAULIC HAMMER DRILL.** This manual contains safety, operation, and routine maintenance instructions. Servicing of hydraulic tools, other than routine maintenance, must be performed by an authorized and certified dealer. Please read the following warning.

** WARNING**

**SERIOUS INJURY OR DEATH COULD RESULT FROM THE IMPROPER REPAIR OR SERVICE OF THIS TOOL.**

**REPAIRS AND / OR SERVICE TO THIS TOOL MUST ONLY BE DONE BY AN AUTHORIZED AND CERTIFIED DEALER.**

For the nearest authorized and certified dealer, call Stanley Hydraulic Tools at the number listed on the back of this manual and ask for a Customer Service Representative.

# CERTIFICATE OF CONFORMITY

CERTIFICATE OF CONFORMITY  
ÜBEREINSTIMMUNGS-ZERTIFIKAT  
CERTIFICAT DE CONFORMITE CEE  
CERTIFICADO DE CONFORMIDAD  
CERTIFICATO DI CONFORMITA

**STANLEY**

Hydraulic Tools

I, the undersigned:  
Ich, der Unterzeichnende:  
Je soussigné:  
El abajo firmante:  
Io sottoscritto:

**Burrows, James**

Surname and First names/Familiennamen und Vornamen/Nom et prénom/Nombre y apellido/Cognome e nome

hereby certify that the construction plant or equipment specified hereunder:  
bestätige hiermit, daß das im folgenden genannten Werk oder Gerät:  
certifies par ceci que l' usine ou l' équipement de construction indiqué cidessous:  
por el presente certifico que la fabrica o el equipo especificado a continuacion:  
certifico che l'impianto o l'attrezzatura sotto specificata:

- Category: Hammer Drill, Hydraulic  
Kategorie:  
Catégorie:  
Categoria:  
Categoria:
- Make/Ausführung/Marque/Marca/Marca **Stanley**
- Type/Typ/Type/Tipo/Tipo: **HD0853101**
- Serial number of equipment:  
Seriennummer des Geräts:  
Numéro de série de l'équipement:  
Numero de serie del equipo:  
Matricola dell' attrezzatura: **All**

5. Year of manufacture/Baujahr/année de fabrication/Año de fabricación/Anno di fabbricazione **2005**

Has been manufactured in conformity with - EEC Type examination as shown.

Wurde hergestellt in Übereinstimmung mit - EEC Typ-Prüfung nach.

Est fabriqué conformément - au(x) type(s) examiné(s) comme indiqué dans le tableau ci-après.

Ha sido fabricado de acuerdo con - tipo examen EEC como dice.

E' stata costruita in conformità con - le norme CEE come illustrato.

	Examen CEE de type			
Directive Richtlinie Directives particulières Directriz Direttiva	No. Nr Numéro No n.	Date Datum Date Fecha Data	Approved body Prüfung durch Organisme agréé Aprobado Collaudato	Date of expiry Ablaufdatum Date d'expiration Fecha de caducidad Data di scadenza
EN	292		Self	NA
EN ISO	8662-3	1992	Self	NA
EN	792-5	1994	Self	NA
EN ISO	3744	1994	Self	NA
Machinery directive	98/37/EC	1998	Self	NA

- Special Provisions: None  
Spezielle Bestimmungen:  
Dispositions particulières:  
Provisiones especiales:  
Disposizioni speciali:

Done at/Ort/Fait à/Dado en/Fatto a Stanley Hydraulic Tools, Milwaukie, Oregon USA Date/Datum/le/Fecha/Data 9/14/05

Signature/Unterschrift/Signature/Firma/Firma

Position/Position/Fonction/Puesto/Posizione Engineering Manager

---

# SAFETY SYMBOLS

---

Safety symbols and signal words, as shown below, are used to emphasize all operator, maintenance and repair actions which, if not strictly followed, could result in a life-threatening situation, bodily injury or damage to equipment.



This is the safety alert symbol. It is used to alert you to potential personal injury hazards. Obey all safety messages that follow this symbol to avoid possible injury or death.



This safety alert and signal word indicate an imminently hazardous situation which, if not avoided, will result in death or serious injury.



This safety alert and signal word indicate a potentially hazardous situation which, if not avoided, could result in death or serious injury.



This safety alert and signal word indicate a potentially hazardous situation which, if not avoided, may result in minor or moderate injury.



This signal word indicates a potentially hazardous situation which, if not avoided, may result in property damage.



This signal word indicates a situation which, if not avoided, will result in damage to the equipment.



This signal word indicates a situation which, if not avoided, may result in damage to the equipment.

Always observe safety symbols. They are included for your safety and for the protection of the tool.

## LOCAL SAFETY REGULATIONS

Enter any local safety regulations here. Keep these instructions in an area accessible to the operator and maintenance personnel.

---

---

---

---

---

# SAFETY PRECAUTIONS

---



Tool operators and maintenance personnel must always comply with the safety precautions given in this manual and on the stickers and tags attached to the tool and hose.

These safety precautions are given for your safety. Review them carefully before operating the tool and before performing general maintenance or repairs.

Supervising personnel should develop additional precautions relating to the specific work area and local safety regulations. If so, place the added precautions in the space provided on page 5.

The model HD08 Hydraulic Hammer Drill will provide safe and dependable service if operated in accordance with the instructions given in this manual. Read and understand this manual and any stickers and tags attached to the tool and hose before operation. Failure to do so could result in personal injury or equipment damage.

- The operator must start in a work area without bystanders. Flying debris can cause serious injury.
- Do not operate the tool unless thoroughly trained or under the supervision of an instructor. Establish a training program for all operators to ensure safe operation.
- Always wear safety equipment such as goggles, ear and head protection, and safety shoes at all times when operating the tool. Use gloves and aprons when necessary.
- The operator must be familiar with all prohibited work areas such as excessive slopes and dangerous terrain conditions.
- Do not inspect, clean or replace any part(s) if the hydraulic power source is connected. Do not inspect or clean the tool while the hydraulic power source is connected. Accidental engagement of the tool can cause serious injury.
- Always connect hoses to the tool hose couplers before energizing the hydraulic power source. Be sure all hose connections are tight and are in good condition.
- Do not operate the tool at oil temperatures above 140°F/60°C. Operation at higher temperatures can cause higher than normal temperatures at the tool which can result in operator discomfort.
- Do not operate a damaged, improperly adjusted, or incompletely assembled hammer drill.
- Never wear loose clothing that can get entangled in the working parts of the tool.
- Keep all parts of your body away from the drill and maintain proper footing and balance at all times.
- When working near electrical conductors, always assume that all conductors are energized and that insulation, clothing and hoses can conduct electricity. Stay a safe distance away from electrical conductors.
- If the hydraulic power supply has been interrupted, place the hammer drill in the OFF position before restarting the hydraulic power supply.
- To avoid personal injury or equipment damage, all tool repair, maintenance and service must only be performed by authorized and properly trained personnel.

# TOOL STICKERS & TAGS

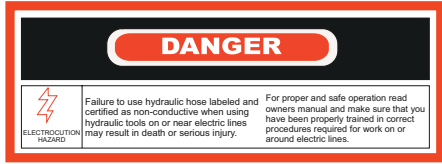

17160  
Electrical Danger Decal

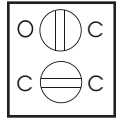

17162  
OC/CC Decal

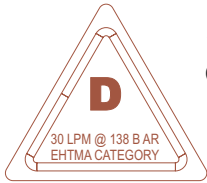

11206  
Circuit C Decal



11207  
Circuit D Decal

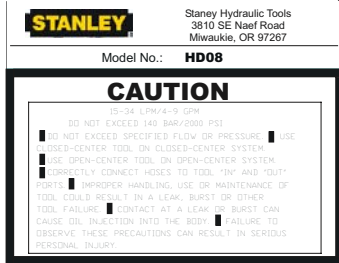

17161  
HD08 Name Tag/GPM Decal

**NOTE**

THE INFORMATION LISTED ON THE STICKERS SHOWN, MUST BE LEGIBLE AT ALL TIMES.

REPLACE DECALS IF THEY BECOME WORN OR DAMAGED. REPLACEMENTS ARE AVAILABLE FROM YOUR LOCAL STANLEY DISTRIBUTOR.

The safety tag (p/n 15875) at right is attached to the tool when shipped from the factory. Read and understand the safety instructions listed on this tag before removal. We suggest you retain this tag and attach it to the tool when not in use.



17179  
Stanley Decal

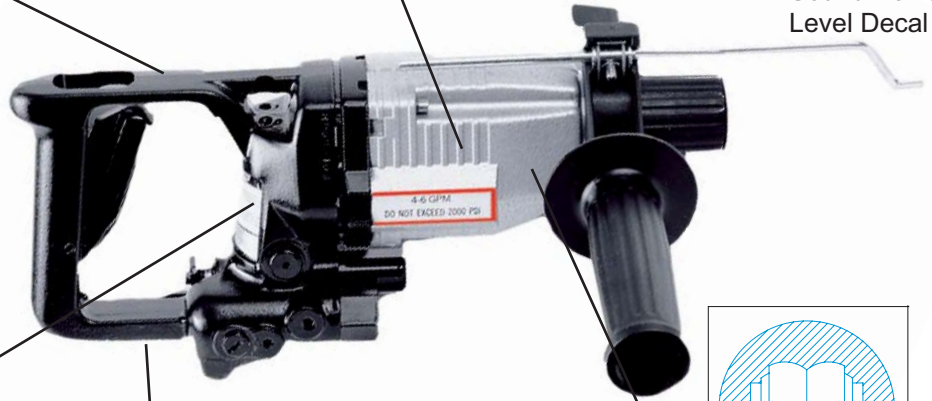

11354  
OC/CC Decal



28323  
CE Decal

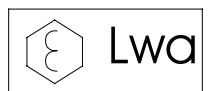

**105**

22796  
Sound Power Level Decal

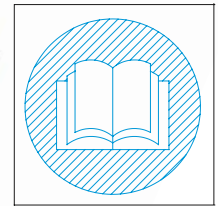

28788  
Manual Decal

**DANGER**

- FAILURE TO USE HYDRAULIC HOSE LABELED AND CERTIFIED AS NON-CONDUCTIVE WHEN USING HYDRAULIC TOOLS ON OR NEAR ELECTRICAL LINES MAY RESULT IN DEATH OR SERIOUS INJURY.

BEFORE USING HOSE LABELED AND CERTIFIED AS NON-CONDUCTIVE ON OR NEAR ELECTRIC LINES BE SURE THE HOSE IS MAINTAINED AS NON-CONDUCTIVE. THE HOSE SHOULD BE REGULARLY TESTED FOR ELECTRIC CURRENT LEAKAGE IN ACCORDANCE WITH YOUR SAFETY DEPARTMENT INSTRUCTIONS.

- A HYDRAULIC LEAK OR BURST MAY CAUSE OIL INJECTION INTO THE BODY OR CAUSE OTHER SEVERE PERSONAL INJURY.
  - DO NOT EXCEED SPECIFIED FLOW AND PRESSURE FOR THIS TOOL. EXCESS FLOW OR PRESSURE MAY CAUSE A LEAK OR BURST.
  - DO NOT EXCEED RATED WORKING PRESSURE OF HYDRAULIC HOSE USED WITH THIS TOOL. EXCESS PRESSURE MAY CAUSE A LEAK OR BURST.
  - CHECK TOOL HOSE COUPLERS AND CONNECTORS DAILY FOR LEAKS. DO NOT FEEL FOR LEAKS WITH YOUR HANDS. CONTACT WITH A LEAK MAY RESULT IN SEVERE PERSONAL INJURY.

**IMPORTANT**

READ OPERATION MANUAL AND SAFETY INSTRUCTIONS FOR THIS TOOL BEFORE USING IT.

USE ONLY PARTS AND REPAIR PROCEDURES APPROVED BY STANLEY AND DESCRIBED IN THE OPERATION MANUAL.

TAG TO BE REMOVED ONLY BY TOOL OPERATOR.

SEE OTHER SIDE

**DANGER**

- DO NOT LIFT OR CARRY TOOL BY THE HOSES. DO NOT ABUSE HOSE. DO NOT USE KINKED, TORN OR DAMAGED HOSE.
- MAKE SURE HYDRAULIC HOSES ARE PROPERLY CONNECTED TO THE TOOL BEFORE PRESSURING SYSTEM. SYSTEM PRESSURE HOSE MUST ALWAYS BE CONNECTED TO TOOL "IN" PORT. SYSTEM RETURN HOSE MUST ALWAYS BE CONNECTED TO TOOL "OUT" PORT. REVERSING CONNECTIONS MAY CAUSE REVERSE TOOL OPERATION WHICH CAN RESULT IN SEVERE PERSONAL INJURY.
- DO NOT CONNECT OPEN-CENTER TOOLS TO CLOSED-CENTER HYDRAULIC SYSTEMS. THIS MAY RESULT IN LOSS OF OTHER HYDRAULIC FUNCTIONS POWERED BY THE SAME SYSTEM AND/OR SEVERE PERSONAL INJURY.
- BYSTANDERS MAY BE INJURED IN YOUR WORK AREA. KEEP BYSTANDERS CLEAR OF YOUR WORK AREA.
- WEAR HEARING, EYE, FOOT, HAND AND HEAD PROTECTION.
- TO AVOID PERSONAL INJURY OR EQUIPMENT DAMAGE, ALL TOOL REPAIR MAINTENANCE AND SERVICE MUST ONLY BE PERFORMED BY AUTHORIZED AND PROPERLY TRAINED PERSONNEL.

**IMPORTANT**

READ OPERATION MANUAL AND SAFETY INSTRUCTIONS FOR THIS TOOL BEFORE USING IT.

USE ONLY PARTS AND REPAIR PROCEDURES APPROVED BY STANLEY AND DESCRIBED IN THE OPERATION MANUAL.

TAG TO BE REMOVED ONLY BY TOOL OPERATOR.

SEE OTHER SIDE

SAFETY TAG P/N 15875 (shown smaller than actual size)

# HYDRAULIC HOSE REQUIREMENTS

## HOSE TYPES

Hydraulic hose types authorized for use with Stanley Hydraulic Tools are as follows:

- ❶ Certified non-conductive
- ❷ Wire-braided (conductive)
- ❸ Fabric-braided (not certified or labeled non-conductive)

Hose ❶ listed above is the only hose authorized for use near electrical conductors.

Hoses ❷ and ❸ listed above are **conductive** and **must never** be used near electrical conductors.

## HOSE SAFETY TAGS

To help ensure your safety, the following DANGER tags are attached to all hose purchased from Stanley Hydraulic Tools. **DO NOT REMOVE THESE TAGS.**

If the information on a tag is illegible because of wear or damage, replace the tag immediately. A new tag may be obtained from your Stanley Distributor.

### THE TAG SHOWN BELOW IS ATTACHED TO “CERTIFIED NON-CONDUCTIVE” HOSE

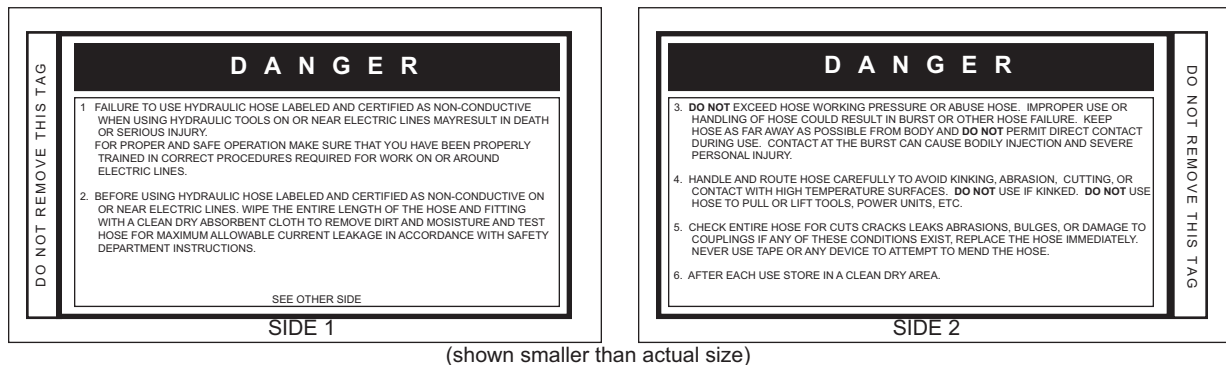

(shown smaller than actual size)

### THE TAG SHOWN BELOW IS ATTACHED TO “CONDUCTIVE” HOSE.

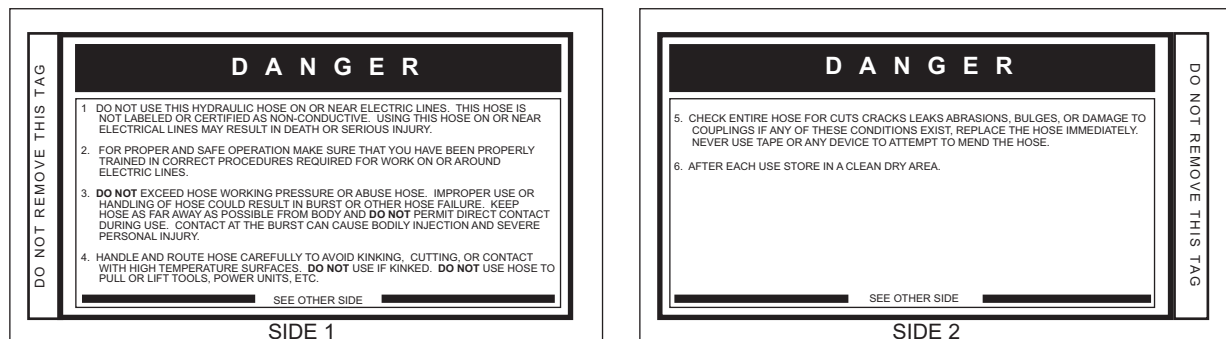

(shown smaller than actual size)

## HOSE PRESSURE RATING

The rated working pressure of the hydraulic hose **must be equal to or higher than** the relief valve setting on the hydraulic system.



# HTMA REQUIREMENTS

## TOOL CATEGORY



## HYDRAULIC SYSTEM REQUIREMENTS

**TYPE I**

**TYPE II**

**TYPE III**

**TYPE RR**

FLOW RATE	4-6 gpm (15-23 lpm)	7-9 gpm (26-34 lpm)	11-13 gpm (42-49 lpm)	9-10.5 gpm (34-40 lpm)
TOOL OPERATING PRESSURE (at the power supply outlet)	2000 psi (138 bar)	2000 psi (138 bar)	2000 psi (138 bar)	2000 psi (138 bar)
SYSTEM RELIEF VALVE SETTING (at the power supply outlet)	2100-2250 psi (145-155 bar)	2100-2250 psi (145-155 bar)	2100-2250 psi (145-155 bar)	2200-2300 psi (152-159 bar)
MAXIMUM BACK PRESSURE (at tool end of the return hose)	250 psi (17 bar)	250 psi (17 bar)	250 psi (17 bar)	250 psi (17 bar)
Measured at a max. fluid viscosity of: (at min. operating temperature)	400 ssu* (82 centistokes)	400 ssu* (82 centistokes)	400 ssu* (82 centistokes)	400 ssu* (82 centistokes)
TEMPERATURE Sufficient heat rejection capacity to limit max. fluid temperature to: (at max. expected ambient temperature)	140° F (60° C)	140° F (60° C)	140° F (60° C)	140° F (60° C)
Min. cooling capacity at a temperature difference of between ambient and fluid temps	3 hp (2.24 kW) 40° F (22° C)	5 hp (3.73 kW) 40° F (22° C)	7 hp (4.47 kW) 40° F (22° C)	6 hp (5.22 kW) 40° F (22° C)
<b>NOTE:</b> Do not operate the tool at oil temperatures above 140° F (60° C). Operation at higher temperatures can cause operator discomfort at the tool.				
FILTER Min. full-flow filtration Sized for flow of at least: (For cold temp. startup and max. dirt-holding capacity)	25 microns 30 gpm (114 lpm)	25 microns 30 gpm (114 lpm)	25 microns 30 gpm (114 lpm)	25 microns 30 gpm (114 lpm)
HYDRAULIC FLUID Petroleum based (premium grade, anti-wear, non-conductive) VISCOSITY (at min. and max. operating temps)	100-400 ssu*	100-400 ssu* (20-82 centistokes)	100-400 ssu*	100-400 ssu*
<b>NOTE:</b> When choosing hydraulic fluid, the expected oil temperature extremes that will be experienced in service determine the most suitable temperature viscosity characteristics. Hydraulic fluids with a viscosity index over 140 will meet the requirements over a wide range of operating temperatures.				

\*SSU = Saybolt Seconds Universal

### NOTE:

These are general hydraulic system requirements. See tool Specification page for tool specific requirements.

# OPERATION

## PREOPERATION PROCEDURES

### CHECK POWER SOURCE

1. Using a calibrated flowmeter and pressure gauge, check that the hydraulic power source develops a flow of 4-9 gpm/15-34lpm at 950-2000 psi/66-140 bar.
2. Make certain that the hydraulic power source is equipped with a relief valve set to open at 2100-2250 psi/145-155 bar.
3. Check that the hydraulic circuit matches the tool for open-center (OC) or closed-center (CC) operation.

### CHECK THE TOOL

1. Make certain all tool accessories are correctly installed. Failure to install tool accessories properly can result in damage to the tool or personal injury.
2. There should be no signs of leaks.
3. The tool should be clean and dry with all fittings and fasteners tight.

### CONNECT HOSES

1. Wipe all hose couplers with a clean lint-free cloth before making connections.
2. Connect the hoses from the hydraulic power source to the tool fittings or quick disconnects. Connect the return hose first and disconnect it last to eliminate or reduce trapped pressure for easier quick-connect fitting attachment.

### Note:

If uncoupled hoses are left in the sun, pressure increase within the hoses can make them difficult to connect. Whenever possible, connect the free ends of hoses together.

3. Observe the flow indicators stamped on the hose couplers to ensure that the flow is in the proper direction. The female coupler on the tool's "IN" port is the inlet coupler. See illustration in back of this manual for tool port identification.

4. Squeeze the drill trigger momentarily. If the drill does not operate, the hoses might be reversed. Verify correct connection of the hoses before continuing.

### DETERMINE TOOL MODEL

#### Open-center or Closed-center Models

Closed-center models have a closed-center decal on the bottom of the handle.

If you are in doubt about the type, test the tool by connecting it to an open-center circuit with the trigger released. If pressure rises more in the circuit with the trigger released than when the trigger is pulled, the tool is closed-center.

#### Open-center/Closed-center Selectable Models

The open-center/closed-center selectable model has a decal on the trigger strut to remind you of the knob positions to select.

## IMPORTANT

Failure to set this spool correctly can cause a mismatch with the hydraulic circuit. This can result in rapid tool heating, seal failure, and poor tool performance.

### Note:

All models have a knurled knob on the spool. This knob cannot be rotated on single-circuit type tools.

## CONTROLS

### FORWARD/REVERSE

Forward/Reverse rotation is selected by the lever on the left-hand side of the tool, as shown in Figure 1.

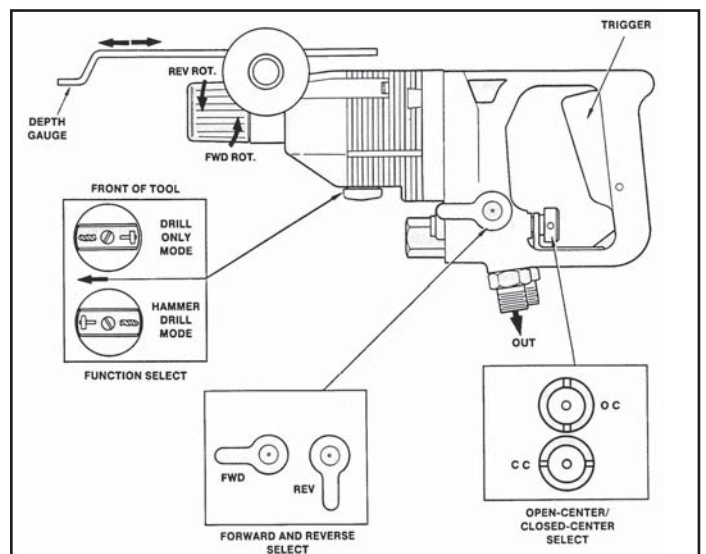

Figure 1. Operator Controls

# OPERATION

## HAMMER DRILL OR DRILL ONLY

Most HD08 operations will be to drill holes in brittle materials such as rock, concrete, or other aggregate. This mode of operation is selected at the knob below the tool nose by aiming the picture of the hammer toward the SDS chuck. For light drilling, the hammering action is turned off by turning the knob so the picture of a drill bit aims at the chuck. In both cases the tool must not be operated without the knob pointing straight front-to-back.

There is no setting for hammering only, however, Figure 2 shows a bull-point chisel bit that can be inserted to chip while the chuck is turning in the hammer drill mode.

## IMPORTANT

Do not operate the tool unless the hammer/drill knob is set to one of the positions described above.

## OPEN-CENTER CLOSED-CENTER OC/CC

The OC/CC selectable model has a knurled knob on the spool end holding the trigger strut and has two opposing set screws showing the circuit setting. If the set screws are horizontal (cross-wise), the setting is for closed-center circuits. If the set screws are on a vertical line, the setting is for open-center circuits. The knob can be twisted to change and should be checked to avoid a wrong setting. A decal on the trigger strut helps remind you of the knob positions to select.

### Note:

Single circuit type tools now have a knob on the spool but it cannot be rotated.

## DEPTH GAUGE

Drilling depth can be set using the depth gauge shown in Figure 1. To set the gauge, loosen the side handle, slide the gauge to the desired position, and tighten the locking knob. Be sure the side handle is tight before operating the tool.

The spacing between lines on the gauge is approximately 10 mm. The depth gauge can be removed when not in use.

## SIDE HANDLE

The side handle assembly, including the depth gauge, fits over the front housing of the hammer drill to assist the operator in maneuvering the tool.

To adjust the side handle to a comfortable position, twist the handgrip in a counterclockwise direction and reposition the handle assembly. Once in position, tighten the handle

assembly by twisting the handgrip in a clockwise direction. Do not clamp the side handle to the black chuck collar. Clamp the handle only to the housing, against the body shoulder. The side handle should be securely attached to the hammer drill during operation.

## BIT INSTALLATION

Bits with SDS Plus shanks are mounted directly into the tool holder of the hammer drill. It is a good practice to slightly grease or oil the bit shanks before inserting them.

To install SDS Plus shanked bits or the bull-point chisel bit, insert the shank into the tool holder at the nose of the hammer drill. Then slightly turn the bit until it can be pushed into the socket. To remove the bit, turn the tool holder sleeve clockwise (while looking from the handle of the drill to the bit holder) until it stops. Then pull the bit out of the tool.

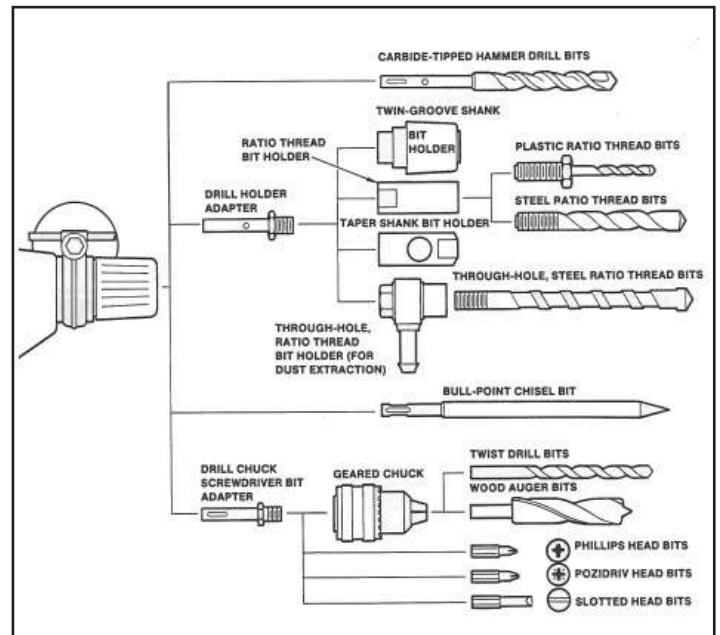

Figure 2. Hammer Drill Accessories

---

# OPERATION

---

To install twin-groove shank, ratio thread shank, taper shank, or through-hole shank bits, install the Drill Holder Adapter as described above. Then simply screw the appropriate bit holder onto the drill holder adapter. Figure 2 illustrates these adapters and bit holders.

To install the Geared Chuck for use with standard drill bits and screwdriver bits in non-percussion drill mode, install the Drill Chuck/Screwdriver Bit Adapter as described above. Then install the appropriate bit into the Geared Chuck and tighten with the chuck key. Figure 2 illustrates the adapter, Geared Chuck, and various standard bits.

---

## DRILL OPERATION

---

Operate the HD08 Hammer Drill as follows:

1. Observe all safety precautions.
2. Install the appropriate adapters and/or bits into the hammer drill. Refer to the BIT INSTALLATION for details.
3. Set the hammer drill controls, side handle, and depth gauge. Refer to the CONTROLS section for details.

### **IMPORTANT**

When operating the hammer drill in hammer mode, always use drill bits and accessories designed for impact type applications. **DO NOT USE STANDARD DRILL BITS OR ACCESSORIES. THESE CAN CRACK OR FRACTURE DURING OPERATION.**

4. Move the hydraulic circuit control valve to the "ON" position.
5. Squeeze the trigger to activate the drill.
6. Release the trigger to stop the drill.

### **MODES OF OPERATION**

The hammer drill can operate in either drill only mode (without percussion) or hammer drill mode (with percussion). In drill only mode, the hammer drill can be used for periodic

light duty drilling. For extended use or heavy duty drilling use the Stanley DLO7 Hydraulic Drill.

The following sections provide operational guidelines for drilling, hammer drilling or chiseling.

### **DRILLING (NON-PERCUSSION)**

Use the Drill Chuck/Screwdriver Bit Adapter and the Geared Chuck for periodic, light-duty drilling applications.

With the Geared Chuck mounted on the tool, loosen the chuck first with the chuck key, and then turn the chuck sleeve counterclockwise (looking at the chuck end of the tool) by hand. Loosen until the bit shank fits into the hole for the shank. Insert the appropriate bit shank into the chuck and tighten the chuck sleeve clockwise by hand. Tighten further by applying the chuck key successively to all three guide holes of the chuck.

The chuck key must not be attached to the tool with a chain, cord, or similar means.

When drilling into small work pieces, secure the piece (by clamping in a vise or otherwise securing it to the work surface) so that the piece is not turned by the drill bit during drilling.

### **IMPORTANT**

When drilling into a structure that might contain electrical wiring, be sure to know the location of the wiring and avoid drilling into it. The housing can carry electrical current from live electrical wires into which the drill is accidentally drilled resulting in injury or death.

### **HAMMER DRILLING (PERCUSSION)**

Press the hammer drill bit against the work surface before squeezing the trigger. Do not operate the drill before contacting the work surface.

When hammer drilling, do not exert heavy pressure on the tool. Applying heavy pressure does not increase the drilling speed. You need only press lightly. When the drill is withdrawn from the work surface, the percussion action of the hammer drill stops.

### **CHISELLING**

Use the Bull-point Chisel Bit for light-duty chiselling work. Press the hammer drill chisel bit against the work surface

---

# OPERATION

---

before squeezing the trigger. As with hammer drilling, do not exert heavy pressure on the tool. Press lightly.

The rotary motion of the hammer drill does not stop when chiselling. The bull-point chisel turns during chiselling. When the chisel is withdrawn from the work surface, the percussion action of the hammer drill stops.

Bull-point chisels that become blunt can be sharpened on a grinding machine.

---

## COLD WEATHER OPERATION

---

If the drill is to be used during cold weather, preheat the hydraulic fluid at low engine speed. When using the normally recommended fluids, fluid temperature should be at or above 50°F/10°C (400 SSU/ 82 centistokes) before use.

Damage to the hydraulic system or drill can result from use with fluid that is too viscous or too thick.

---

# TOOL EQUIPMENT & CARE

---

## NOTICE

In addition to the Safety Precautions on page in this manual, observe the following for equipment protection and care.

- Make sure all couplers are wiped clean before connection.
- The hydraulic circuit control valve must be in the “OFF” position when coupling or uncoupling hydraulic tools. Failure to do so may result in damage to the quick couplers and cause overheating of the hydraulic system.
- Always store the tool in a clean dry space, safe from damage or pilferage.
- Make sure the circuit PRESSURE hose (with male quick disconnect) is connected to the “IN” port. The circuit RETURN hose (with female quick disconnect) is connected to the opposite port. Do not reverse circuit flow. This can cause damage to internal seals.
- Always replace hoses, couplings and other parts with replacement parts recommended by Stanley Hydraulic Tools. Supply hoses must have a minimum working pressure rating of 2500 psi/172 bar.
- Do not exceed the rated flow. Refer to the Specifications page in this manual for correct flow rate and model number. Rapid failure of the internal seals may result.
- Always keep critical tool markings, such as warning stickers and tags legible.
- Tool repair should be performed by experienced personnel only.
- Make certain that the recommended relief valves are installed in the pressure side of the system.
- Do not use the tool for applications for which it was not intended.

# TROUBLESHOOTING

If symptoms of poor performance develop, the following chart can be used as a guide to correct the problem.

When diagnosing faults in operation of the hammer drill, always check that the hydraulic power source is supplying the correct hydraulic flow and a pressure to the tool as

listed in the table. Use a flowmeter known to be accurate. Check the flow with the hydraulic fluid temperature at least 80° F / 27° C.

PROBLEM	CAUSE	SOLUTION
Drill will not start	Power not being supplied.	Check to make certain that both hoses are connected.
		Turn hydraulic circuit control valve ON.
	Defective quick-disconnect.	Check each disconnect separately. Replace as necessary.
	Jammed motor and/or parts.	Separate modules and inspect. See Service Instructions. Do not force parts together.
	Flow reversed through hoses.	Correct the power source control valve position. Prevent reverse flow by using only one port from the valve for pressure, the return tool hose to the cooler and the filter line. Correct the quick-disconnect male/female routing per instructions and arrows on the fittings.
Low hammer impact or drilling torque.	Incorrect hydraulic flow.	Check that the hydraulic power source is producing 4-9 gpm / 15-34 lpm at 750-2000 psi / 53-140 bar.
	Defective quick-disconnect.	Check each disconnect separately.
	Worn impact mechanism.	Separate modules and repair or replace impact mechanism. See Service Instructions.
	Incorrect grease.	Metabo (forward module) mechanism is full of fluid or contaminants or is improperly greased. "Clean out, re-lubricate, and/or repair per Metabo instructions. See instructions for separating the rear module to supply Metabo portion to the dealer for service".
	Reversing spool incorrectly installed.	Reversing spool upside down. Do not separate modules. See Service Instructions.
	Hydraulic circuit relief set too low, hoses too restrictive or the hydraulic fluid is too thick.	Set relief valve at 2100 psi / 145 bar. See Service Instructions.
	Fluid restriction in hose or valve. Excess back pressure.	Locate and remove restriction.
		Use correct fluid.
		Fluid not warmed-up. Preheat system.
		Hoses too long for hose ID. Use shorter hose.
	Priority flow control valve or reverse check valve is malfunctioning.	Do not separate modules. See Service Instructions.

# TROUBLESHOOTING

PROBLEM	CAUSE	SOLUTION
Low hammer impact or drilling torque. <i>(continued)</i>	Flow reversed through hoses.	Correct the power source control valve position. Prevent reverse flow by using only one port from the valve for pressure, the return tool hose to the cooler and the filter line. Correct the quick-disconnect male/female routing per instructions and the arrows on the fittings.
Drill operates in only one direction. Forward or reverse.	Reverse spool incorrectly installed.	Do not separate modules. Reassemble. See Service Instructions.
	Reverse spool faulty.	Do not separate modules. Replace reverse spool. See Service Instructions.
	Tool hose flow is reversed.	Tool must not be reversed by reversing hose flow. The tool is only designed for flow as indicated by the designations cast on the housing.
Drill runs too fast. Impact mechanism or screws broken.	Incorrect hydraulic flow.	Check the hydraulic power source is not producing over 9 gpm / 34 lpm at 750-2000 psi / 53-140 bar.
	Hydraulic flow reversed.	Correct the tool hoses. IN and OUT per instructions and if the power supply valve is reversible, reconnect the tool return hose to the oil cooler or to the filter directly.
	Priority valve faulty.	Do not separate modules. Remove, inspect and replace priority valve if necessary. See Service Instructions.
Trigger operation erratic. Control difficult.	Trigger mechanism and strut area blocked by debris.	Do not separate modules. Clean trigger area. See Service Instructions.
Fluid leaks at housing seam.	Motor screws loose.	Separate modules. Tighten to recommended torque.
	Motor cap seal worn or missing.	Separate modules. Replace as required.
	Motor cap/main housing damaged.	Separate modules. Replace as required.
Fluid leaks at reversing spool.	Damaged o-rings.	Do not separate modules. Replace them as required.
	Wrong hydraulic fluid. Circuit too hot.	See Operating Instructions for correct fluid/circuit specifications.
	Hydraulic pressure and return hoses reversed.	Correct hose connections.
Fluid leak at air gap between module.	Oil leak at motor shaft seal.	Repair or replace. See Service Instructions.
Fluid gets hot. Power unit working hard.	Open center tool on a closed center circuit or vice versa.	Use tools to match circuit.
	Circuit relief set too low.	Adjust relief valve to 2100-2250 psi / 135-155 bar.
	Too much fluid going through tool.	Adjust flow for 9 gpm / 34 lpm maximum.
	Circuit is generating high heat with flow controls.	Use pump size and rpm for producing needed flow only. Eliminate circuit heating causes.
	Circuit has contaminants that have caused wear and high heat generation.	Replace worn pump and valves. Install a large clean filter and keep the fluid clean.



# SPECIFICATIONS

Rotation Speed at 6 gpm .....	1175 rpm
Blows per Minute at 6 gpm .....	4500 blows
Weight .....	6 lbs / 2.7 kg
Length .....	13.8 in. / 35 cm
Height .....	5.5 in. / 14 cm
Pressure .....	750-2000 psi / 50-114 bar
Flow Range .....	3-9 gpm / 11-34 lpm
Optimum Flow .....	6 gpm / 22.8 lpm
Porting .....	-8 SAE O-Ring
Connect Size and Type .....	-8 SAE O-Ring
Motor .....	Integral
Bit Type.....	SDS Plus

SOUND POWER AND VIBRATION DECLARATION	
Measured A-weighted sound power level, Lwa (ref. 1pW) in decibels	102 dBA
Uncertainty, Kwa, in decibels	3 dBA
Measured A-weighted sound pressure level, Lpa (ref. 20 µPa) at operator's position, in decibels	94 dBA
Uncertainty, Kpa, in decibels	3 dBA
Values determined according to noise test code given in ISO 15744, using the basic standard ISO3744 NOTE- The sum of a measured noise emission value and its associated uncertainty represents an upper boundry of the range of values which is likely to occur in measurements.	
Declared vibration emission value in accordance with EN 12096	
Measured vibration emission value: a	10.3 m/sec <sup>2</sup>
Uncertainty: K	0.8 m/sec <sup>2</sup>
Values determined according to ISO 8662-3	

# ACCESSORIES

Part Number	Description
16769.....	1/2-inch Geared Chuck (requires chuck adapter p/n 16770)
16770.....	Chuck Adapter (used with geared chuck p/n 16769)

Figure 2 illustrates the hammer drill accessories listed above.

# SERVICE PARTS

Part Number	Description
17183.....	Service Kit, Includes Shaft Keeper and Knob
18142.....	Seal Kit

---

# SERVICE

---

Good maintenance practice keeps the hammer drill on the job and increases its service life.

The most important maintenance practice is to keep the hydraulic fluid clean at all times. Contaminated fluid causes rapid wear and/or failure of internal parts.

Follow the procedure contained in the “HYDRAULIC SYSTEM REQUIREMENTS” section of this manual to ensure peak performance from the tool.

Do not disassemble the tool until you know whether the problem is in the hydraulic power supply, the front module, or the Stanley power and control (rear) module. Then only disassemble the tool as necessary to repair as required. KEEP CONTAMINANTS SUCH AS DIRT AND GRIT AWAY FROM INTERNAL PARTS AT ALL TIMES

Always determine and correct the cause of the problem prior to reassembly. Further wear and tool failure can result if the original cause is not corrected.

---

## TOOL MODULE ASSEMBLIES

---

The HD08 Hammer Drill consists of two distinct modules that can be serviced independently; a forward module and rear module.

- The forward module, consists of the chuck, side handle, reduction gearing, and pneumatic-coupled impact mechanism. Metabo Corporation distributors can service this module.
- The rear module, consists of the main housing assembly motor, trigger, on-off spool, reversing valve, flow control valve, and reverse check valve. Stanley Hydraulic Tool dealers can service this module.

Figure 3 illustrates the service modules of the hammer drill.

Isolate the service problem to the circuit, forward module or rear module before separating the modules. Repairs involving the control valves, trigger, and strut do not require separation of the modules. The TROUBLESHOOTING section contains information to help isolate the problem.

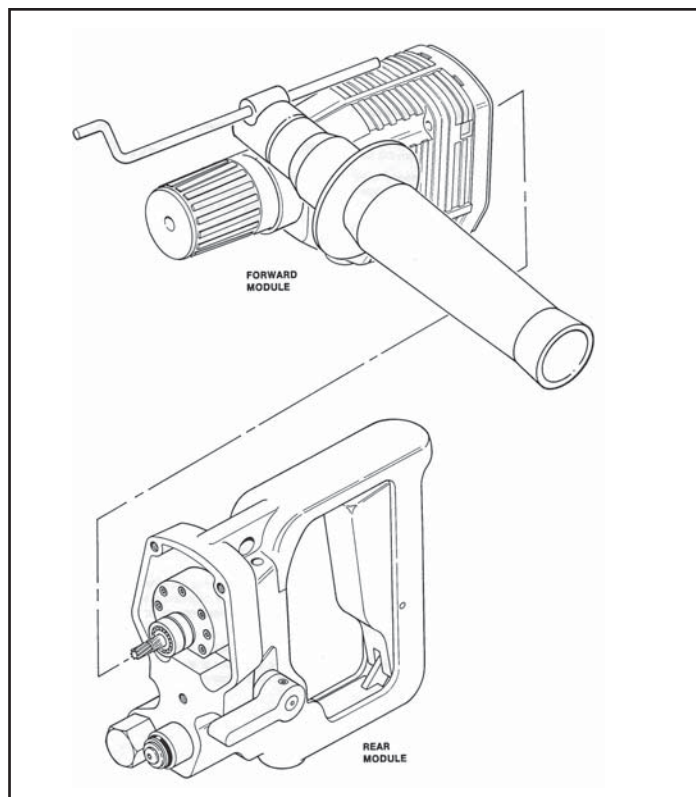

Figure 3. Hammer Drill Service Modules

---

## PRIOR TO DISASSEMBLY

---

- Clean the exterior of the tool.
- Obtain Seal Kit (Part Number 18142) so all seals exposed during disassembly can be replaced during reassembly. Note the orientation of seals before removal. Install new seals in the same position as the original seals. Note: For orientation of the parts identified in the following procedures, refer to the parts illustration located at the center of this manual.

---

## SERVICE NOT REQUIRING MODULE SEPARATION

---

If the reversing spool is identified as the faulty part, remove it as described below.

1. Identify the reversing spool in the parts illustration.
2. Remove the reversing lever from the reversing spool by loosening the set screw until the lever is free. Do not let the reversing spool slide toward the center of the housing.

---

# SERVICE

---

3. Remove the retaining ring from the other end of the reversing spool, again ensuring that the spool does not slide.

4. Push in on the reversing spool from the retaining ring side only until the o-ring on the other side is exposed. To prevent damage to the opposite o-ring, keep it from passing near the center of the housing. Remove the exposed o-ring.

5. Push in on the lever end of the reversing spool until it slides out the outer side of the housing. Remove the remaining o-ring.

Inspect the through bore for scoring or scratching. Scores or scratches in the bore indicate contaminated hydraulic fluid. Flush out the hydraulic power supply, replace filters and then replace the fluid using Stanley recommended fluids. Inspect the o-rings for damage. If pieces of the o-rings are missing, they might remain inside the tool where they can block hydraulic passages. Locate and remove these o-ring fragments from the tool.

10. Install the retaining ring.

11. Assemble the lever to the reversing spool.

## PRIORITY VALVE SERVICE

The priority valve, located at the bottom-right of the Stanley power and control (rear) module, prevents excessive flow and motor overspeed that can destroy the Metabo (forward) module. If the tool has low performance, or closed-center flow through is high when the trigger is released, the problem can be either the valve is stuck open or the o-rings around the valves are damaged, missing or leaking fluid. If this is the case, inspect and assemble as follows:

1. Identify the priority valve in the parts illustration.

2. Loosen the priority valve by turning its hex end with a wrench. Remove the valve.

3. Inspect and remove the priority valve o-rings. If pieces of the o-rings are missing, they might remain inside the tool where they can block fluid passages. Locate and remove these o-ring fragments.

4. Inspect the priority valve, making sure the orifice in the small end is not blocked and that the plunger is not jammed. The plunger is spring-loaded toward the small end and should be pressed toward the hex end with a soft, flat-end rod. Replace the priority valve if necessary.

5. Clean the priority valve and the valve bore with a degreasing solvent. Replace all a-rings and apply clean grease or o-ring lubricant to all parts.

6. Replace the priority valve and tighten.

## CHECK VALVE SERVICE

The check valve does not require regular maintenance. During normal operation, the check valve blocks fluid flow from the "IN" port to the "OUT" port, but allows fluid flow the other way if the tool is reverse plumbed. If this valve is identified as faulty, inspect and assemble as follows.

1. Identify the check valve (consisting of the check plug, o-ring, compression coil spring, and steel ball) in the parts illustration.

2. Shake the tool and listen for the steel ball rattling in the check valve chamber. The steel ball should be held against the seat by the spring and should not rattle.

3. Loosen the check plug by turning the plug with a large screwdriver. Remove the plug, compression coil spring, and steel ball.

4. Inspect the surface around the small hole where the steel ball normally seats. If the surface around the hole is cut or worn, fluid bypasses the motor and reduces performance.

5. Inspect and remove the check valve o-ring. If pieces of the o-ring are missing, they might remain inside the tool where they can block hydraulic passages. Locate and remove these o-ring fragments.

6. Clean the check plug, compression coil spring, and steel ball with a degreasing solvent. Replace the o-ring. Apply clean grease or o-ring lubricant to all parts.

7. Place the steel ball in the hole and tap on the ball with a soft brass or aluminum rod and a small hammer. This tapping action seats the ball.

8. If the steel ball rattled when the tool was shaken in Step 2, replace the compression coil spring.

9. Replace the check plug and tighten with a large screwdriver.

## ON/OFF SPOOL SERVICE

Your HD08 Hammer Drill has one of two types of On/Off valve assemblies depending upon the date of manufacturer. On/Off valve assemblies prior to S/N 737 configured for use in OC circuits or CC circuits are attached to the trigger strut with a retaining ring. Combination On/Off valve assemblies or after S/N 737 configured for use in either OC or CC circuits are attached to the trigger strut through

---

# SERVICE

---

a knob, which is either fixed or is used to select the proper circuit type.

To service this component, first identify which style On/Off valve assembly with which your drill is equipped. Follow the corresponding removal instructions:

**Note:**

**Do not remove the stop washer and sealed screw from the spool assembly front end. The screw must remain sealed in the threads so it does not leak.**

If your hammer drill is equipped with the early OC or CC circuit On/Off valve assembly, remove the assembly as follows:

1. Remove the retaining ring attaching the spool end to the trigger strut.
2. Push the spool from the trigger end, out the front of the drill housing.

If your hammer drill is equipped with the combination OC/CC circuit On/Off valve assembly, or OC or CC after S/N 865 remove the assembly as follows:

1. Identify the On/Off valve assembly in the parts illustration.
2. Remove the set screw under the o-ring in the front of the spool cartridge on single circuit type tools.
3. Twist the circuit selection knob (located forward of the trigger mechanism) to 45 degrees and pick out the o-ring from the front end of the spool. Remove the two steel balls from the holes under the o-ring.
4. Loosen the two hex socket set screws in the circuit selection knob and remove the knob to free the spool assembly.
5. Push the spool from the trigger end, out of the front of the drill housing.

Inspect and remove the o-rings from the On/Off spool. If pieces of the o-rings are missing, they might remain inside the tool where they can block fluid passages. Locate and remove these o-ring fragments.

Clean the spool and spool housing with a degreasing solvent, then inspect for scratches and other signs of wear. Replace any worn parts.

**Note:**

**DO NOT remove the stop washer and sealed screw from the spool assembly front end. It must be sealed in the thread to hold fluid in the spool center.**

**Note:**

**If the OC/CC valve is to be assembled, do not install the steel balls until after the spool assembly is installed.**

6. Grease the o-rings and install in the groove of the valve bore and on the spool groove with the backup rings nearest the valve end.
7. Push the spool assembly into the valve bore and through the hole at the end of the trigger strut.
8. Secure the spool to the trigger strut by the retaining ring, for early open-center or closed-center valves, or by aligning the hex socket set screw holes in the knob with the cross hole in the spool. Secure the selector knob to the spool end using the two hex socket set screws.
9. On single circuit applications, rotate the valve spool to the desired position (ie. the set screws in the knob are side to side for CC and up and down aligned with the trigger for OC) and install the set screw in the spool housing using a small amount of locktite. Advance the screw until snug, then withdraw 1/2 turn check the spool to make sure it moves freely.
10. Place the two 1/8-inch steel balls in the opposing holes at the groove in the other end of the valve extension and retain them with an o-ring.

**Note:**

**The spool must stroke from the position where the trigger strut contacts the valve sleeve (with the trigger pulled to the stop washer). The spool stop washer must also contact the valve sleeve front end when the trigger is released.**

## TRIGGER SERVICE

If the trigger mechanism is identified as the faulty area, disassemble and clean the mechanism as follows:

1. Remove the retaining ring, or knob and two set screws attaching the On/Off spool end to the trigger strut.
2. Squeeze the trigger. If the trigger does not move freely through the normal operating range, proceed to Step 3. Otherwise, the trigger mechanism is operating properly.

---

# SERVICE

---

3. Remove the trigger pivot roll pin that extends through the tool handle.
4. Lift the trigger and strut out of the trigger cavity.
5. Clean the trigger, compression coil spring, strut, and trigger cavity. Remove any debris that could block the operation of the trigger mechanism.
6. Grease the compression coil spring and the trigger pivot hole with a light, water-resistant lubricant.
7. Place the trigger and strut into the trigger cavity.
8. Install the trigger pivot roll pin that extends through the tool handle.
9. Install the retaining ring, or knob and two set screws attaching the On/Off spool end to the trigger strut.

---

## SEPARATION OF MODULES

---

### **IMPORTANT**

Do *not* separate the modules until you read the following procedures, and procure the Stanley seal kit. Hold the motor shaft in place, until all seven motor cap bolts are removed and the motor is lifted from the housing.

Two types of attachments are used to connect the forward and rear modules. The early module attachment consists of two 10-24 x 2-inch hex socket capscrews and lockwashers (high) and one 10-24 hex socket Allen nut with lockwasher (low) around the Metabo (forward) module. The Allen head nut is on a stud that remains with the Stanley power and control (rear) module when separated.

Later models, designated with a suffix "A," use 8-32 hex socket head caps crews and Metabo dowel sleeves at the three attachment points.

1. Loosen the three fasteners around the red Metabo plate and lift the mechanism from the rear module straight up. The motor ball bearing must stay against the rear module as viewed between the modules. Gradually lift the forward module off. **DO NOT LET THE BALL BEARING PULL AWAY FROM THE REAR MODULE. THE MOTOR BEARING AND SEALING SYSTEM CAN BE DAMAGED.**

2. Attach the motor shaft retaining bridge (from the service kit) over the ball bearing in place and secure with the 10-24 caps crews or 8-32 capscrews to fit the hammer drill being repaired.

---

## FORWARD MODULE SERVICE

---

The forward module should be cleaned and lubricated at least once a year (more often if the drill is used frequently). Be sure to use the proper grease in the correct amounts and locations. Contact your local Metabo (electric hammer drill) dealer for regular maintenance instructions.

If the forward module is faulty or malfunctioning, it can be serviced by your Metabo dealer. Since your Metabo dealer is not equipped to service or operate the rear module, the two modules must be separated before sending the forward module for service. Your Metabo dealer tests the forward module using Metabo's electric rear module or returns the module to you for testing after service.

---

## REAR MODULE SERVICE

---

### DISASSEMBLY

### **IMPORTANT**

The shaft/ball bearing must be held against the module until the motor bolts and motor cap are free of the module. Failure to do so can cause damage to the cap, bearings and seal.

If the rear module is malfunctioning and separation of the forward and rear modules is required for service, proceed as follows:

1. Obtain Service Kit (Part Number 17183) before disassembly of the module.
2. Separate the forward and rear modules. Refer to the SEPARATION OF MODULES section.
3. Position the retainer bridge (from the service kit) over the rear module's motor shaft and bearing and secure with the hex socket capscrews. (See Figure 4). The rear module can be operated separately only when the retainer bridge is installed.

---

# SERVICE

---

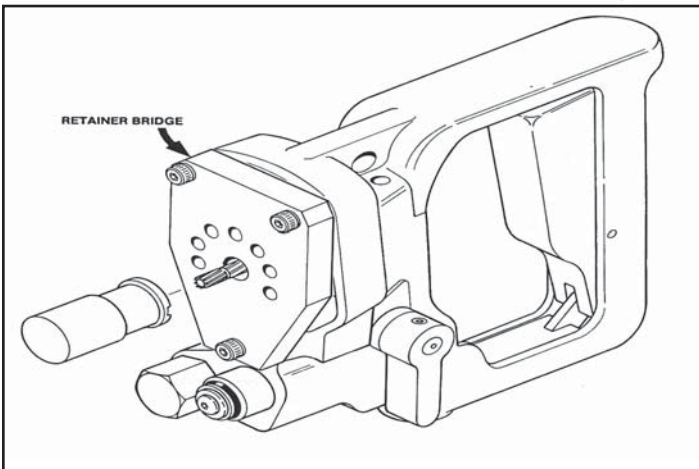

Figure 4. Rear Module with Retainer Bridge

## INSPECTION

Clean and inspect all parts.

Gears should have square corners, straight and evenly polished flanks, and smooth ends. Shafts must be smooth and not discolored and should show no wear on the shaft diameters under the bushings or the seal. Both drive shaft bushings and both idler shaft bushings should be smooth and grey. If they are bronze in color, fluid contamination has caused wear. The flat surfaces of the motor cap and housing provide a fluid seal and must be smooth and free of scratches, grooves or nicks. Grooves are a sure sign of fluid contamination. If any components do not appear as described, replace them. If wear indicates fluid contamination, clean the power supply before use.

The bearing should spin smoothly on the motor shaft without rattle or roughness. Slight drag should be apparent, because of the grease inside of the bearing. Pack the bearing with Exxon "Andok C" grease and spin to remove excess grease.

Assure that all fluid holes are clean. Use degreasing solvent and compressed air to clear clogged holes. Dry and apply clean grease or a-ring lubricant to all parts.

## ASSEMBLY

Assemble the module as follows:

1. After the parts have been inspected and new parts collected, cleaned, and greased for assembly, perform the following steps in the order given.

2. The ball bearing must be on the shaft against the gear side of the retaining ring. Press a bearing on the shaft by pressing against the inner race ONLY. Place the backup washer (hollow end against the ball bearing) on from the keyway end. Install new seals in the sealiner. The quad ring shaft seal is inserted into the counter bore followed by the metal backup washer. Liberally grease these parts and press them into the motor cap, shaft seal end first.

3. Apply thick grease to the shaft keyway, then slide the shaft through the sealiner. Place the key and drive gear on the shaft. Add the idler shaft and gear. With heavy grease in the face groove around the gears, install the o-ring into the face groove. Be sure the dowels are located in both holes either in motor cap or main housing.

4. Holding the motor cap and shaft assembly in one hand and the main housing in the other hand, carefully align the parts and ease the two assemblies together. Holding the two portions straight allows them to be slipped together smoothly without forcing. The motor cap assembly must

4. When the ball bearing and shaft is secured against the module, with the service bridge. hydraulic power can be connected. After connecting hydraulic power, notice if any leaks occur around the seal retainer (shaft seal failure) or around the motor cap (motor face seal failure). The trigger can be pulled to test the motor for starting and smooth running. If the motor does not start, it can be turned by gripping it with the plastic shaft knob supplied in the service kit. Do not use pliers or hard metal tools on the helical gear.

5. Disconnect the hoses and drain all fluid from the tool.

6. Remove the seven hex capscrews from the motor cap, then remove the center bridge.

7. With the shaft pointing up, pry around the motor cap (without tipping it) until it is loose. Remove the motor cap with the attached shaft and bearing. **DO NOT PULL ON THE BALL BEARING OR SHAFT.**

8. From the internal side of the motor cap, remove the drive gear, idler gear, and drive key. If these pieces are already dislodged, locate them in the main housing and remove. The key under the drive gear must be removed before the ball bearing (with the shaft and seal) can be separated from the motor cap.

9. Remove the shaft and the attached bearing from the motor cap. Remove the shaft back-up washer from the motor cap.

10. To remove the sealiner and shaft seals, place the backup washer on the shaft, lightly grease the shaft OD and insert it into the sealiner partially engaging the inner bushing. Lightly apply shop air pressure from the bushing side of the shaft bore until the sealiner slides onto the shaft. Exercise caution during this procedure to avoid damage to the sealiner or causing the parts to be forcibly ejected.

---

# SERVICE

---

rest flat in the housing.

5. Position the retainer bridge (from the service kit) over the motor shaft and bearing. Secure with the three fasteners.

6. Slide the plastic shaft knob (from the service kit) over the motor shaft and turn the knob with your fingers. The motor should turn without forcing. If the shaft turns freely, lubricate the seven hex capscrews and install them through the clearance holes in the retainer bridge. If the shaft does not turn freely, disassemble and repeat steps 4 and 5. Tighten the seven hex capscrews to a torque value of 20 in. lb/2.25 Nm.

7. Turn the plastic shaft knob again to verify that the motor shaft turns freely.

8. Remove the plastic shaft knob. With the retainer bridge in place, the motor should operate smoothly without binding. Attach the tool to the hydraulic power source as described in the PREOPERATION PROCEDURES section. Connect hydraulic power to the ports (not reversed) and pull the trigger several times in each rotation direction using the reversing lever on the left side.

9. If the motor starts smoothly and consistently, attach the shaft knob. Hold the shaft from turning, then pull the trigger. SLOWLY turn the shaft in the direction chosen with the reversing lever and make sure the motor tries to make the shaft go faster through at least two turns in each direction (using the reversing lever to change the motor direction).

10. If the motor does not pull in each direction, it must be disassembled, checked, and assembled again. If any parts were forced together, if foreign particles are inside, or the motor is not accurately aligned, the motor will not run properly.

used in the tool being assembled.

The model with a 10-24 stud in the new module below the motor is secured by two 10-24 x 2-inch hex socket cap-screws above and an Allen nut on the stud (each with lock-washers). Lubricate the threads before assembling, then tighten them to a torque value of 44 in. lb / 5 Nm.

Later models need the three hollow sleeves inserted around the 8-32 hex socket capscrew threads in the Metabo (forward module) mechanism mount face. Threads should be lubricated and tightened to a torque value of 29 in. lb/3.3 Nm.

---

## REJOINING THE MODULES

---

After servicing the forward or rear module, verify that the module is operating properly. For forward module service, have your local Metabo (electric hammer drill) dealer test the module with their electric rear module. For rear module service, run the module with the retainer bridge installed. After verifying proper operation of each module, rejoin the modules as follows:

1. Release the service bridge from the front of the new module housing by removing the three fasteners while carefully retaining the shaft in place until it is secured by the Metabo (forward module) mechanism.

2. Check the parts illustration to locate the type of fasteners

# PARTS ILLUSTRATION

Model HD08531G  
HD0835101 (CE Only)

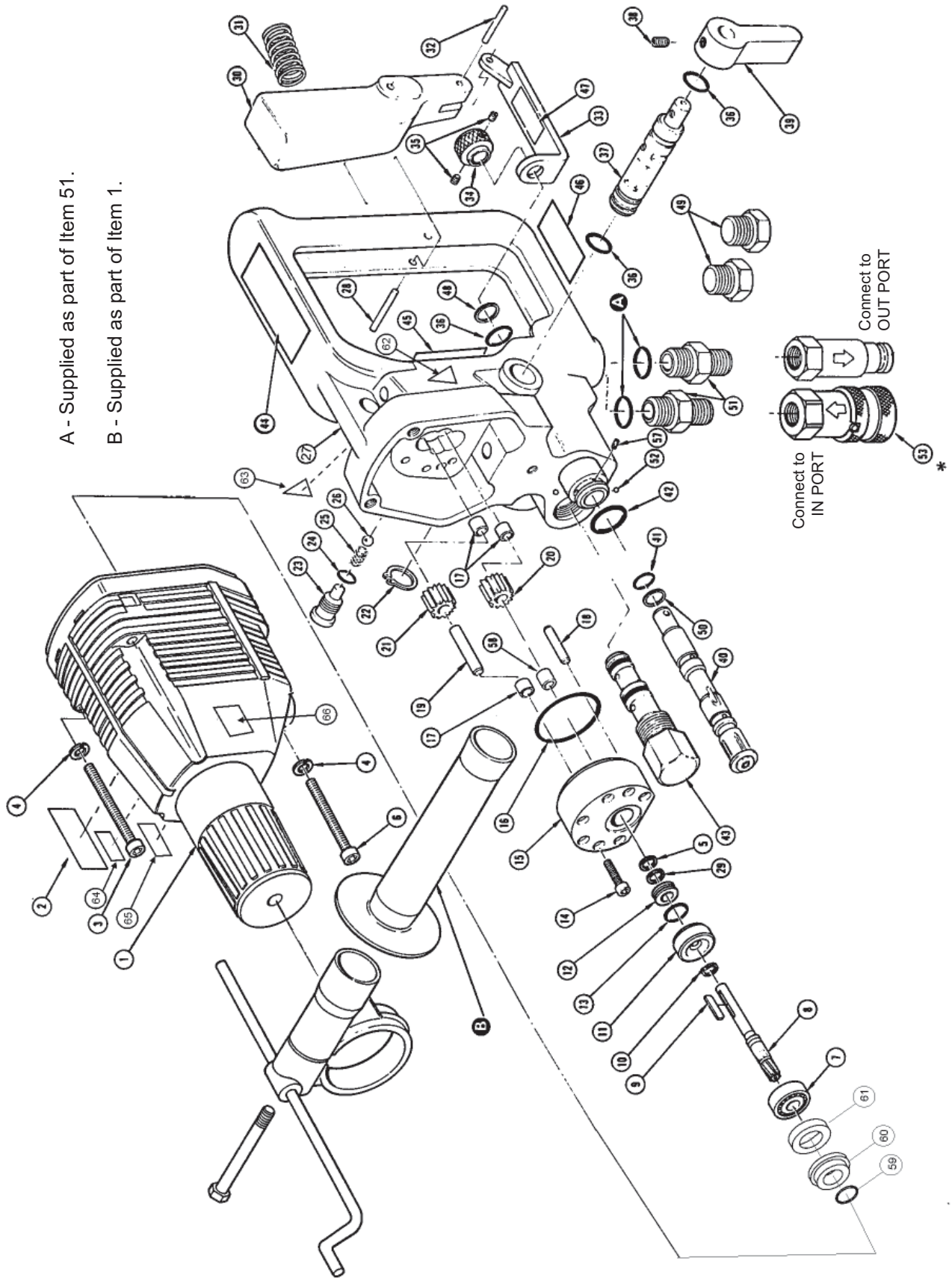



# PARTS LIST

Item	Part No.	Qty	Description
1	47450	1	Hammer Drill Mechanism
2	17179	1	Stanley Decal
3	56713	2	Capscrew
4	00341	3	Lockwasher, #8
5	00179	1	Motor Seal Washer
6	00068	1	Capscrew
	<b>47451</b>	<b>1</b>	<b>Main Housing Assembly (Includes Items 17 &amp; 23 thru 27)</b>
7	15905	1	Bearing
8	56711	1	Motor Shaft
9	15896	1	Key
10	00224	1	Retaining Ring
11	15893	1	Back-up Washer
12	23327	1	Seal Liner
13	00106	1	O-Ring
14	15909	7	Capscrew
15	<b>23330</b>	<b>1</b>	<b>Motor Cap Assembly (Includes Items 17, 18 &amp; 59)</b>
16	00621	1	O-Ring
17	05205	3	Busing
18	00289	2	Dowel Pin
19	15890	1	Idler Shaft
20	15895	1	Drive Gear
21	15894	1	Idler Gear
22	17904	1	Retaining Ring
23	15956	1	Check Plug
24	350792	1	O-Ring
25	01602	1	Compression Coil Spring
26	15966	1	Steel Ball
27	35541	1	Main Housing
28	17668	1	Roll Pin, 3/16 x 1-1/4
29	00112	1	Quad Ring
30	16598	1	Trigger
31	16647	1	Compression Coil Spring
32	16648	1	Roll Pin, 5/32 x 5/8
33	17815	1	Trigger Strut
34	17817	1	Knob
35	02837	2	Set Screw

Item	Part No.	Qty	Description
36	07626	3	O-Ring, 1/2 x 5/8 x 1/16
37	15904	1	Reversing Spool
38	17897	1	Set Srew
39	04939	1	Lever
40	17899	1	On-Off Spool OC/CC
41	17924	1	O-Ring, 3/8 x 1/2 x 1/16
42	350810	1	O-Ring, 9/16 x 3/4 x 3/32
43	15908	1	Priority Valve, 6 gpm
44	17160	1	Electrical Danger Decal
45	17161	1	Name Tag/Caution Decal
46	11354	1	OC/CC Decal (OC/CC Models Only)
47	17162	1	OC/CC Decal (OC/CC Models Only)
48	07224	1	Back-up Ring, 1/2 x 1/16
49	06345	2	Plastic Plug
50	07223	1	Back-up Ring, 3/8 x 1/16
51	00936	2	Adapter Fitting
52	21338	2	Ball, 5/32 SST (OC/CC Only)
53	03971	1	Coupler Set
54	--	-	No Item
55	--	-	No Item
56	--	-	No Item
57	22668	1	Set Screw
58	23328	1	Bushing
59	18660	1	O-Ring, Metabo
60	56712	1	Slinger, Metabo
61	66380	1	Spacer
62	11206	1	Circuit Type C Decal (CE Only)
63	11207	1	Circuit Type D Decal (CE Only)
64	28323	1	CE Decal (CE Only)
65	28788	1	Manual Decal (CE Only)
66	22796	1	Sound Power Decal (CE Only)
	26428	1	Lock-Out Kit (Shipped Un-Installed)
	18142	1	Seal Kit

---

# WARRANTY

---

Stanley Hydraulic Tools (hereinafter called "Stanley"), subject to the exceptions contained below, warrants new hydraulic tools for a period of one year from the date of sale to the first retail purchaser, or for a period of 2 years from the shipping date from Stanley, whichever period expires first, to be free of defects in material and/or workmanship at the time of delivery, and will, at its option, repair or replace any tool or part of a tool, or new part, which is found upon examination by a Stanley authorized service outlet or by Stanley's factory in Milwaukie, Oregon to be DEFECTIVE IN MATERIAL AND/OR WORKMANSHIP.

## EXCEPTIONS FROM WARRANTY

**NEW PARTS:** New parts which are obtained individually are warranted, subject to the exceptions herein, to be free of defects in material and/or workmanship at the time of delivery and for a period of 6 months after the date of first usage. Seals and diaphragms are warranted to be free of defects in material and/or workmanship at the time of delivery and for a period of 6 months after the date of first usage or 2 years after the date of delivery, whichever period expires first. Warranty for new parts is limited to replacement of defective parts only. Labor is not covered.

**FREIGHT COSTS:** Freight costs to return parts to Stanley, if requested by Stanley for the purpose of evaluating a warranty claim for warranty credit, are covered under this policy if the claimed part or parts are approved for warranty credit. Freight costs for any part or parts which are not approved for warranty credit will be the responsibility of the individual.

**SEALS & DIAPHRAGMS:** Seals and diaphragms installed in new tools are warranted to be free of defects in material and/or workmanship for a period of 6 months after the date of first usage, or for a period of 2 years from the shipping date from Stanley, whichever period expires first.

**CUTTING ACCESSORIES:** Cutting accessories such as breaker tool bits are warranted to be free of defects in material and or workmanship at the time of delivery only.

**ITEMS PRODUCED BY OTHER MANUFACTURERS:** Components which are not manufactured by Stanley and are warranted by their respective manufacturers.

- a. Costs incurred to remove a Stanley manufactured component in order to service an item manufactured by other manufacturers.

**ALTERATIONS & MODIFICATIONS:** Alterations or modifications to any tool or part. All obligations under this warranty shall be terminated if the new tool or part is altered or modified in any way.

**NORMAL WEAR:** any failure or performance deficiency attributable to normal wear and tear such as tool bushings, retaining pins, wear plates, bumpers, retaining rings and plugs, rubber bushings, recoil springs, etc.

**INCIDENTAL/CONSEQUENTIAL DAMAGES:** To the fullest extent permitted by applicable law, in no event will STANLEY be liable for any incidental, consequential or special damages and/or expenses.

**FREIGHT DAMAGE:** Damage caused by improper storage or freight handling.

**LOSS TIME:** Loss of operating time to the user while the tool(s) is out of service.

**IMPROPER OPERATION:** Any failure or performance deficiency attributable to a failure to follow the guidelines and/or procedures as outlined in the tool's operation and maintenance manual.

**MAINTENANCE:** Any failure or performance deficiency attributable to not maintaining the tool(s) in good operating condition as outlined in the Operation and Maintenance Manual.

**HYDRAULIC PRESSURE & FLOW, HEAT, TYPE OF FLUID:** Any failure or performance deficiency attributable to excess hydraulic pressure, excess hydraulic back-pressure, excess hydraulic flow, excessive heat, or incorrect hydraulic fluid.

**REPAIRS OR ALTERATIONS:** Any failure or performance deficiency attributable to repairs by anyone which in Stanley's sole judgement caused or contributed to the failure or deficiency.

**MIS-APPLICATION:** Any failure or performance deficiency attributable to mis-application. "Mis-application" is defined as usage of products for which they were not originally intended or usage of products in such a manner which exposes them to abuse or accident, without first obtaining the written consent of Stanley. PERMISSION TO APPLY ANY PRODUCT FOR WHICH IT WAS NOT ORIGINALLY INTENDED CAN ONLY BE OBTAINED FROM STANLEY ENGINEERING.

**WARRANTY REGISTRATION:** STANLEY ASSUMES NO LIABILITY FOR WARRANTY CLAIMS SUBMITTED FOR WHICH NO TOOL REGISTRATION IS ON RECORD. In the event a warranty claim is submitted and no tool registration is on record, no warranty credit will be issued without first receiving documentation which proves the sale of the tool or the tools' first date of usage. The term "DOCUMENTATION" as used in this paragraph is defined as a bill of sale, or letter of intent from the first retail customer. A WARRANTY REGISTRATION FORM THAT IS NOT ALSO ON RECORD WITH STANLEY WILL NOT BE ACCEPTED AS "DOCUMENTATION".

## NO ADDITIONAL WARRANTIES OR REPRESENTATIONS

This limited warranty and the obligation of Stanley thereunder is in lieu of all other warranties, expressed or implied including merchantability or fitness for a particular purpose except for that provided herein. There is no other warranty. This warranty gives the purchaser specific legal rights and other rights may be available which might vary depending upon applicable law.



Stanley Hydraulic Tools  
3810 SE Naef Road  
Milwaukie, Oregon  
503-659-5660 / Fax 503-652-1780  
[www.stanley-hydraulic-tools.com](http://www.stanley-hydraulic-tools.com)

---