



FISH DISPLAY

MANUAL OF INSTRUCTIONS FOR USE AND INSTALLATION



MODELS: VML12	VML15	VML18	Fish displays case Malaga Series
----------------------	--------------	--------------	---



VML 18

General Strengths

- ✓ **Sanitation.** Quick ability to take off shelves and slides for interior cleaning. Each cabinet has a drain at the bottom of the unit. When cleaning the unit make sure the drain hose is routed to a floor drain.
- ✓ **Control systems.** Higher precision in managing temperature settings. Greater ability to adjust of temperature ranges as per the end user's requirement.
- ✓ **100% Tested.** All condenser units are tested 100%, in helium chambers to refrigerant leak detections.
- ✓ **Certified.** AENOR audited and certified by internationally recognized firm. ISO 9001:2008 (Quality); ISO 14001:2004 (Environmental); OSHAS 18001:2007 (Prevention and Worker Safety).
- ✓ **Lighting.** LED lighting in the canopy and shelves reduces the energy consumption by 80% and 90% compared to a traditional bulb. Provides a much better light quality.

MODELS	Dimensions (mm)			Lateral Thickness (mm)	Surface Exposure (m ²)	Gross Volume (L)	Regimen Temp. (°C)	Ref.	Ref. Weight (gr.)	Net Weight (Kg.)
	Width	Depth	High							
VML 12	1250	900	1235	40 + 40	0,79	1480	-1°C / +1°C	R134a	360	142
VML 15	1562	900	1235	40 + 40	0,99	1825	-1°C / +1°C	R134a	550	163
VML 18	1875	900	1235	50 + 50	1,19	2173	-1°C / +1°C	R134a	650	187

WE RESERVE THE RIGHT TO CHANGE SPECIFICATIONS WITHOUT PRIOR NOTICE

MODELS: VML12	VML15	VML18	Fish displays case Malaga Series
----------------------	--------------	--------------	---

STANDARD FEATURES

➤ **Exterior**

- Exterior of Stainless Steel AISI 304,
- Worktop of stainless steel AISI 304,
- Sliding door back,
- Curved tempered security glass system.

➤ **Interior**

- Interior of Stainless Steel AISI 304,
- Base of enameled steel tube,
- Drain inside,
- LED lighting.

➤ **Insulation**

- Insulation by free CFC's polyurethane foam high-pressure injected with density 40 Kg/m³,
- Zero ODP and Low GWP.

➤ **Refrigeration**

- Temperature and defrost regulated by a digital controller,
- Manual defrost,
- System of Ventilated condensation
- System of Static+Board Evaporation,
- Evaporator coil coated with anti-corrosion material,
- Climate class 4 (32°C, 55HR).

➤ **Electrical**

- Electrical connection: 220 V / 1 ph / 50 Hz



OPTIONAL

- Wheels,
- Frontal LED lighting,
- Electrical connection 220 V / 1 ph / 60 Hz.,
- Electrical connection 115 V / 1 ph / 60 Hz.

MODELS	Dimensions Palletizing (mm)			Crated Weight (Kg.)	Power (W)	Comp. (HP)	Cooling Power (W to -10°C)	Cons. (kWh/24h)	Inten. (A)	Level Noise (dB)	Container 20'/40'/40'HC	Trailer
	Width	Depth	High									
VML12	1340	1020	1340	155	620	1/3	464	8,7	3,1	54,7	8 / 17 / 17	23
VML15	1720	1020	1340	182	895	1/2	1208	12,5	3,2	55,6	6 / 13 / 13	15
VML18	2030	1020	1340	195	1094	7/8	1606	15,3	4,5	56,4	5 / 11 / 11	13

WE RESERVE THE RIGHT TO CHANGE SPECIFICATIONS WITHOUT PRIOR NOTICE

MODELS: VML12	VML15	VML18	Fish displays case Malaga Series
----------------------	--------------	--------------	---

PLAN VIEW

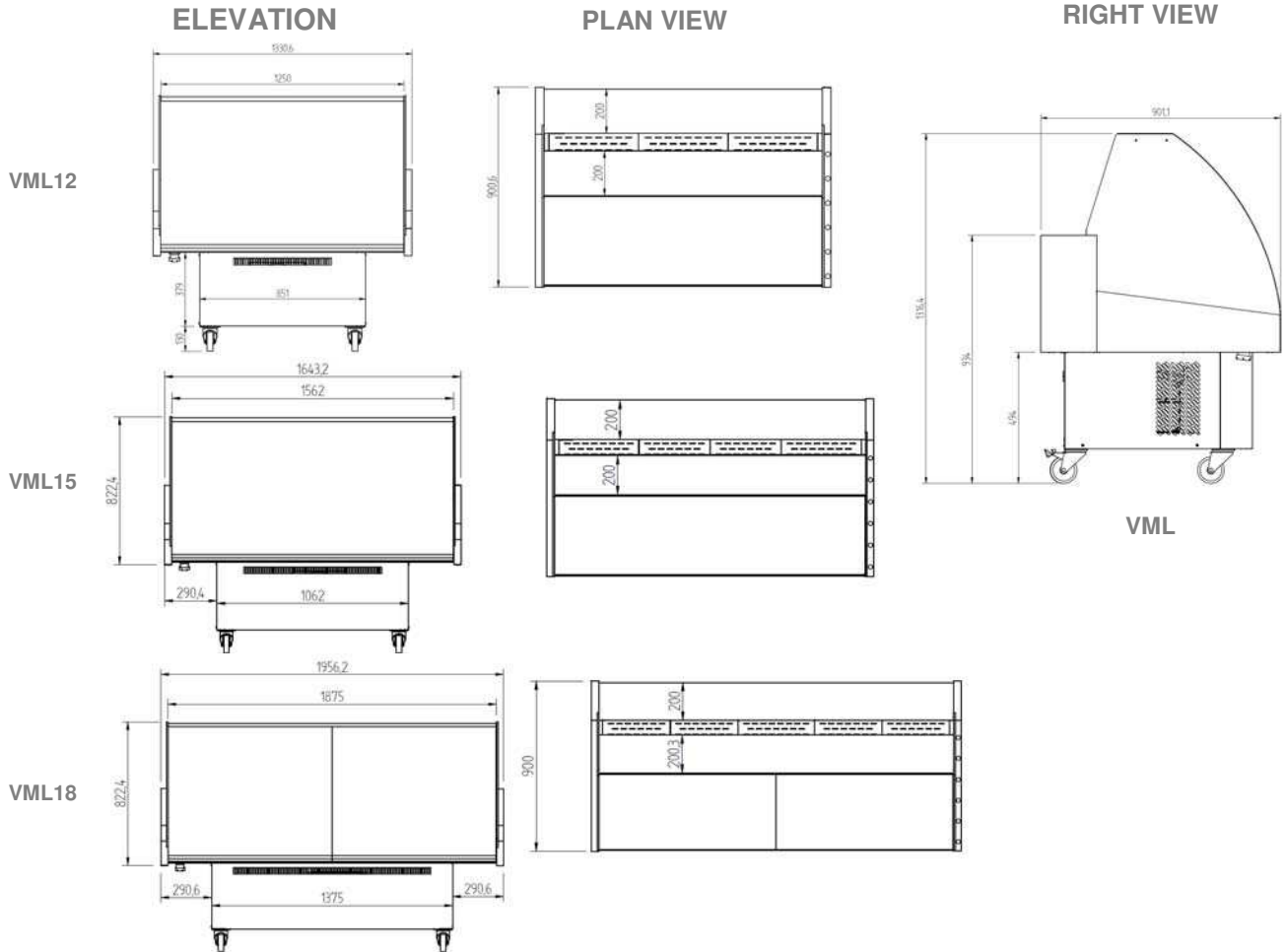

CONNECTIONS

MODELS	A (mm)	B (mm)	C (mm)	D (mm)	E (mm)
VML12	110,6	430	164	140,5	468
VML15	110,6	430	164	140,5	468
VML18	110,6	430	164	140,5	468

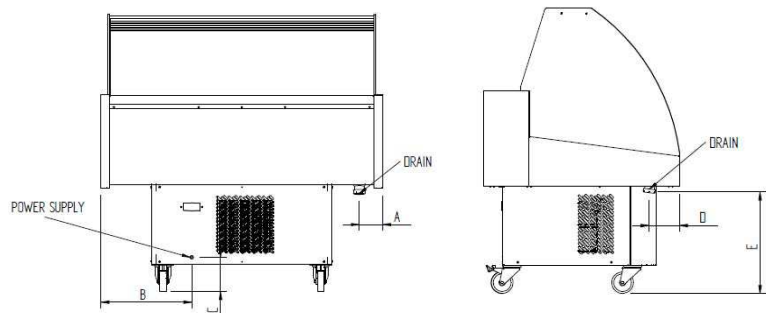

Review: 01 Date: 10/02/2014

WE RESERVE THE RIGHT TO CHANGE SPECIFICATIONS WITHOUT PRIOR NOTICE