

Douglas County, Oregon

ARES

(Amateur Radio Emergency Services)

Annex A to the Section Operations Manual

2015 Annual Training Plan



Revised Aug 10, 2015

Table of Contents

Mission Statement	4
Goals for 2015:	4
Basic Elements:	5
Procedures:	5
Expectations of Members:	5
Douglas County ARES Training Calendar – 2015	6
Pictorial Representation of Section Training Program	9
ARES/RACES Communications Technician Skills-based Task List	11
ARES/RACES Operations AEC Skills-based Task List	12
ARES/RACES EC Skills-based Task List	13
Training Topics:	14
Winlink System Design:.....	14
RMSExpress Basics – Telnet:	14
RMSExpress Intermediate – Telnet, VHF/UHF, HF:	14
RMSExpress Advanced – Telnet, VHF/UHF, HF and Peer-To-Peer:	14
Jump Kit Preparation:.....	15
Message traffic training using ICS 213, 309:.....	15
Task Book Certification Training:.....	15
Emergency Communication:	15
Hand Held Radio Programming:	15
IS 100/144/200/700:	16
Repeaters – overview:	16
Douglas County ARES Emergency Communications Plan Review:.....	16
Douglas County Emergency Operations Center Operations:	16
Western Douglas County Operations Center (Reedsport) Operations:	16
Set up and operate Incident Communications trailer:	16
Winmor RMS Express Training – HF radio:.....	17
WSPR – (Weak Signal Propagation Reporting) – HF radio - Introduction:	17
SAR (Search and Rescue) Repeater Training, maintenance and deployment:.....	17
Visiting the Douglas County Dispatch Center (911):.....	17
Antenna Design and Testing:	17

Anderson Power Poles:..... 17
Fox Hunt – ELT (Emergency Location Transmitter):..... 17
Telephone Call Down Review: 17
Ham equipment grounding principles: 18
ORSDF (Oregon State Defense Force) – function and support: 18
Quarterly Reports: 18
Search and Rescue Support: 18
Incident Command Trailer: 18
Basic Mapping and GPS for ARES Members..... 18
Douglas County River and Stream Gauges 18

Mission Statement

Oregon Douglas County Section ARES exists to provide a viable first response to local or regional communications system outages or overloads. Using Amateur Radio equipment, systems, and operators as directed by the local Emergency Manager, ARES provides back-up voice and digital communications networks to designated agencies.

Goals for 2015:

1. Maintain Intermediate Unit Certification
2. Increase the number of active Red Card members with Radio Operator Skills-Based Task list completion from 59% in 2014 to 75% by the end of 2015.
3. Provide Emergency Communications Training to Supported Agency Members
4. Increase active Red Card members by 10% (from 27 to 30).
5. Increase active White Card Members by 10% (from 8 to 9).

Douglas County ARES

Individualized Training Program

Basic Elements:

General meetings are scheduled on the second Thursday of each month at the Roseburg Emergency Operations Center. The meeting will be followed with one or more trainings. Some of the meetings and trainings will be held at the Western Douglas County Operations Center in Reedsport or other facilities.

Members are expected to take training and practice regularly to adequately to perform in an exercise or an actual deployment.

Procedures:

- Members will select the Skills Based Tasks they want to complete (Radio Operator, Communications Technician, Operations Assistant Emergency Coordinator or Emergency Coordinator). Trainings will be offered through the year.
- Members will receive training Skills Based Tasks after the General Membership meetings and can be certified at that time. Certificates of completion will be issued to the member and record keeping by the Emergency Coordinator to assure credit for the member. Completion records will be provided to the ASEC for Training upon request.
- Members wishing additional or personal training can request one-on-one training at a time suitable to the participant and a qualified instructor. Ask any AEC or the EC.

Expectations of Members:

- Members must have completed all required FEMA course work (IS 100, 200 and 700) before entering into the Skills based Task Training program.
- Members must complete 2-hours of training or participate for two hours in activities each month that develop/maintain the skills for voice and/or Winlink communications.
- Members should participate in at least one State SET, exercise, or actual event each year, as many NETs (VHF and HF) and meetings as their schedule allows. Attendance records are kept for all scheduled events and NETS..
- Current members shall complete the minimum tasks for Radio Operator by the end of 2015.
- Members will complete an appropriate level of Winlink training by the end of 2015.

Douglas County ARES Training Calendar – 2015

Trainings may be offered concurrently as member attendance dictates.
Schedule may be revised as necessary throughout the year

January 8 10am – Noon Roseburg EOC

New Member Orientation (if necessary)
Radio Operator Task Training
Discussion of training and exercises scheduled for 2015
Distribution of the ARES member roster and revised Emergency Communication Plan
Presentation about and tour of Dispatch Center – Kathy Cross

February 12 10am – Noon Roseburg EOC

New Member Training (if necessary)
Radio Operator Task Training
Anderson Power Pole presentation – Roth
Antenna Design and Testing – Williams W6QWK
Review of Emergency Plan - Roth

February 27 10am – 2pm Western Douglas County EOC - 2680 Frontage Rd, Reedsport

Review of equipment in Communications Facility – located behind Fire Station.
A tour of the communications facility and EOC. Training will be provided on all Ham equipment, satellite Internet, IP Phones, local Wi-Fi and computer systems including use of shared printer will be conducted. There will be a discussion of the operation of the automatic natural gas generator system.

March 12 10am – Noon Roseburg EOC

Radio Operator Tasks Training
Message Traffic Handling – Roth
Search and Rescue support – Harbin W7OEN
Maintenance and deployment of portable SAR Repeater – Harbin W7OVN and Eifert AE7ER
Quarterly testing and reports for OEM - Roth

April 9 10am – Noon Roseburg EOC

SET review and Planning
RMSExpress Intermediate – Roth
Phone call down review and practice - Roth
Preparation and planning for Spring SET - Roth
Incident Command Trailer Training – Eifert AE7ER and Hutchison KE7JFQ

April 25 8 am – 5pm Roseburg and Reedsport EOC

Spring SET (Simulated Emergency Test) QuakeEX I
Details to be distributed before SET

May TBA – Joint Exercise - Red Cross, ARES and Sheriff's Office Animal Support

This joint exercise will be coordinated by the Sheriff's office. The Red Cross will set up a sheltering site and Animal control will simulate care of shelter residents pets. Challenges with large animals (horses, cows, goats, etc) will be included as well as dogs, cats, birds, etc.

May 14 10am – Noon Roseburg Red Cross – 870 NE Alameda Ave, Roseburg

SET Review, Critique, Lessons Learned.
Handheld radio programming -

RMS Express - Advanced - Roth
Review Red Cross Equipment – VHF, HF, VHF Packet, Manual Tuner – Roth
Lowband 47.42Mhz radio will be demonstrated (base station and radio in Emergency Response Vehicle)
Demonstration of Honda 1KW gas generator and wiring to support emergency communications and lighting.
Review of how Winlink works - Roth

June 11 10am – Noon Roseburg Public Safety – 700 SE Douglas Ave, Roseburg

Field Day– planning
Review equipment at EOC site and test VHF and HF
Radio Operator Task Training (ICS 213 and 309)
Testing of communications from this facility to the County EOC will be conducted.

June 27 – 28 Field Day

Many trainings and practice at field day event
Fox Hunt – Stumpe K7AZW
ELT – Hyers – W7TCH
Various field stations operating Winlink, HF SSB, Winmor, WSPR, VHF FM, VHF Packet.

July 9 10am – Noon Roseburg EOC

New Member Training (if necessary)
Radio Operator Task Training
Ham station Grounding guidelines – Roth KE7MVX
Jump Kit Preparations - Roth

August 13 10am – Noon Roseburg EOC

New Member Training (if necessary)
Radio Operator Tasks Training
ARES Leadership Conference – Roth KE7MVX
Repeater operation in area – what is linked to what and coverage areas
Red Cross Safe and Well support training

August TBA – Red Cross Emergency Communications Plan exercise

ARES will participate in a live test of the Red Cross Emergency Communications Plan.
Testing will include the Red Cross office in Roseburg (VHF, HF, and Winlink), County EOC, Western Douglas County EOC, Medford Red Cross, Eugene Red Cross and Portland Regional Red Cross Headquarters (Winlink and HF only).

September 10 10am – Noon Roseburg EOC

New Member Training (if necessary)
Radio Operator Tasks Training
Support for Partner Agencies – Roth
ICS213 and ICS309 Review and Exercises – Roth

September – 10 – Galesville Dam Exercise – Pre Exercise Training/Exercise

ARES will set up EOC
Test all communications
Define all participants and train prior to main exercise

September 16 – Galesville Dam Exercise

EOC will be activated
ARES will be providing EOC and field support

Supported Agencies Active

September TBA 0900 – 1400 Douglas County

ARES State Wide Field Exercise – EOC's will be active
Most members can operate from home
Supported agencies active

October 8 10am – Noon Roseburg EOC

AAR/IP for Field Exercise
Radio Operator Task Training
RMSExpress Advanced - Roth
Handheld radio programming -
Emergency Communications Plan Review – Roth

October 10 and 11th – 8am – 5pm both days

QuakeEX II State Wide Exercise – details as they are released

October 15 10:15 am – from home locations

Great American Shakeout Exercise
VHF, HF Net Check in
Telephone call down exercise

November TBA 8am – 2pm Roseburg and Reedsport EOC

State SET (Simulated Emergency Test)

December 10 10am – Noon Roseburg EOC

SET Review, Critique, Lessons Learned.
Radio Operator Task Training
Quarterly equipment testing and reporting to OEM - Roth
Douglas County Linked Repeaters details - Roth

Pictorial Representation of Section Training Program

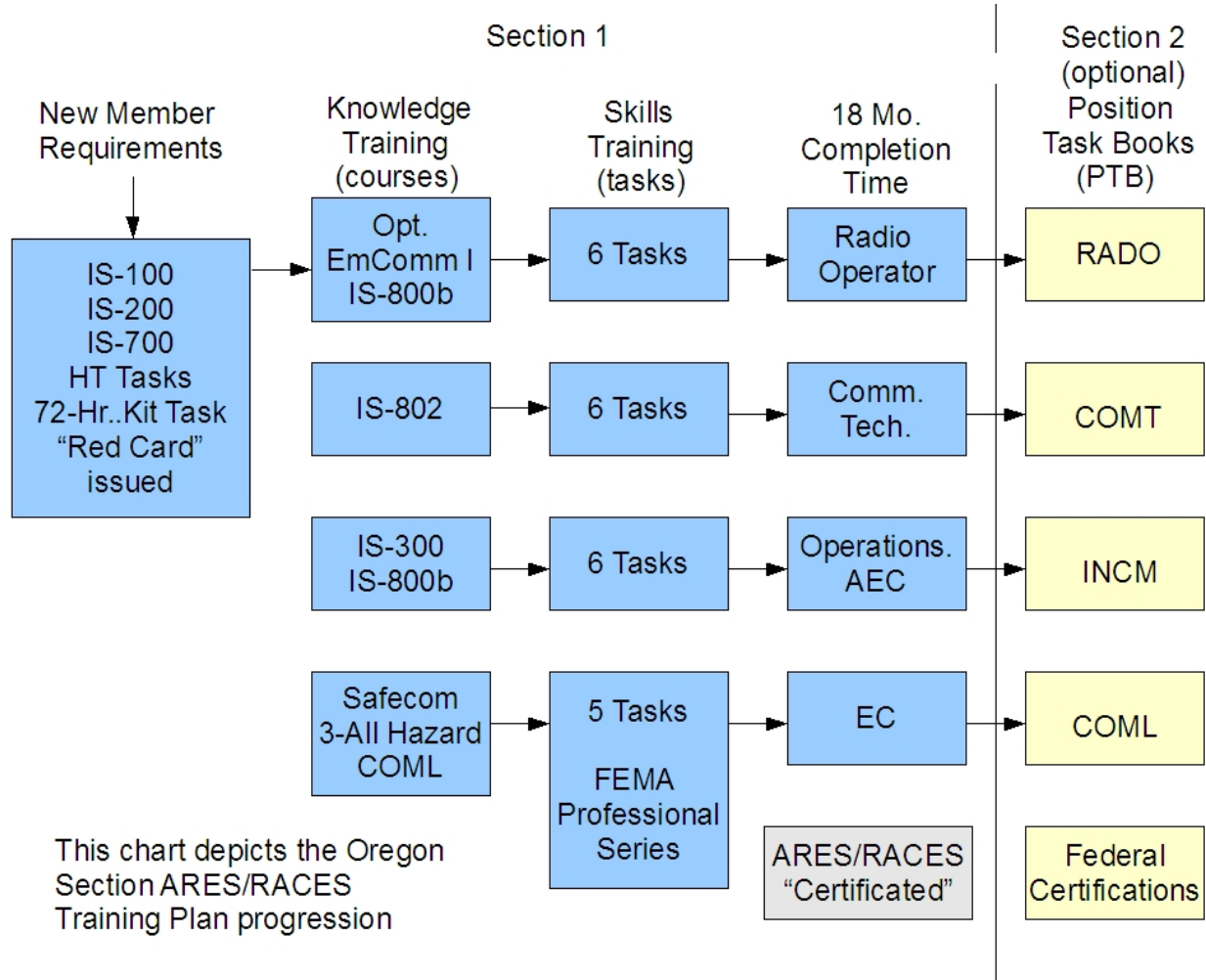

This chart depicts the Oregon Section ARES/RACES Training Plan progression

ARES/RACES Radio Operator Skills-based Task List

1. **Obtain and assemble information and materials needed for assignment.**

- Obtain a copy of the county ARES/RACES frequency plan
- Obtain and pre-program a suitable personal HT radio programmed with the county frequency plan, and have a spare battery pack (dry cell)
- Assemble a 72-hour kit suitable for your specific county mission and assignment

Completed Date: _____ Evaluator: _____

2. **Demonstrate familiarity with communications equipment, procedures and basic functions/capabilities**

- Be able to input a frequency, tone, and offset into your personal HT and mobile radio
- Be able to operate the base station radios in use at your operating position
- Know what frequencies and/or nets are present on what radios, and the purpose of each

Completed Date: _____ Evaluator: _____

3. **Correctly fill out and/or process appropriate forms.**

- ICS-309 Communications Log
- ICS-213 NCR form for tactical voice traffic and for internal use

Completed Date: _____ Evaluator: _____

4. **Communicate information effectively to Net participants.**

- Use correct Radio and Telephone protocols
- Write legibly and speak clearly
- Correctly recite the standard ITU Phonetic Alphabet
- Use standard terminology, designators, acronyms, and symbols
- Acknowledge requests, and provide feedback

Completed Date: _____ Evaluator: _____

5. **Use appropriate communication protocol when responding to emergency situations.**

- Demonstrate radio net procedures used for emergency traffic
- List types of information never to be spoken over voice nets

Completed Date: _____ Evaluator: _____

6. **Use appropriate communication protocol when responding to routine requests/information.**

- Demonstrate radio voice net procedures used for routine traffic
- Discuss the difference between tactical traffic, emergency, and health & welfare traffic
- List the preferred means and modes for processing the above

Completed Date: _____ Evaluator: _____

ARES Member name and Call Sign: _____

Reviewed and Approved for Certificate

EC: _____

ARES/RACES Communications Technician Skills-based Task List
(Tasks Required are in addition to Radio Operator Tasks, IS 800. Optional IS802)

1. **Determine appropriate location for communications equipment.**

- Observe spatial separation requirements of antenna systems
- Elevate radiating elements sufficiently

Completed Date: _____ Evaluator: _____

2. **Install communication equipment at determined locations.**

- Evaluate terrain, path, accessibility, and safety
- Select and install the correct antenna system for a given frequency and application

Completed Date: _____ Evaluator: _____

3. **Establish installation priorities while adhering to safety standards regarding communications.**

- Observe and abate RF exposure and RF burn concerns
- Avoid creating tripping hazards
- Use caution when climbing or doing overhead work
- Use appropriate headgear (hard-hats) and safety goggles
- Handle high-amperage and/or high voltage equipment with care

Completed Date: _____ Evaluator: _____

4. **Test components of communications equipment to ensure the incident systems are operational.**

- Using a Service Monitor or individual items of test equipment:
 - Measure SWR of antenna systems
 - Determine condition of a length of coaxial cable
 - Measure power output of a radio
 - Determine receiver sensitivity
 - Measure deviation of a transmitted signal
 - Determine transmit frequency
 - Rapidly assess the operational status of a radio.

Completed Date: _____ Evaluator: _____

5. **Clone or program radios.**

- OADN system radios.
- ECC standard radios.
- Help unit members with programming their personal radios.

Completed Date: _____ Evaluator: _____

6. **Perform operational test of communications systems throughout duration of the incident.**

- Demonstrate how to operationally assess distant repeaters
- Demonstrate how to assess remote packet nodes
- Accomplish minor field repair.
- Place orders for replacement of equipment.
- Plan for battery replacement.
- Minimize interruptions in system operation.

Completed Date: _____ Evaluator: _____

ARES Member Name and Call Sign: _____

Reviewed and Approved for Certificate EC: _____

ARES/RACES Operations AEC Skills-based Task List

(Tasks Required in Addition to Radio Operator Tasks: IS800, Enroll in IS300 and Optional IS802)

1. **Be self-proficient in, and supervise radio operators to:**

- Ensure use of radio/telephone logs.
 - ICS-309 Communications Log
 - ICS-214 Unit Log
- Ensure proper radio procedures and protocols
 - ICS-213 NCR form for internal use
 - ICS-213 used for tactical voice traffic
 - Properly construct an Airmail Subject Line Date/time group
 - Correct use of all Airmail Templates
 - Process ICS-213 presented on USB drive
 - Process ICS-213 accessed over LAN
 - Access Winlink over Telnet, Packet, and Pactor

Completed Date: _____ Evaluator: _____

2. **Implement a document use and filing system.**

- Property loss/damage reports
- ICS 213, General Message
- ICS 214, Unit Log
- ICS-309, RadioLog
- Agency specific forms
- Within the Airmail file structure for digital incident traffic

Completed Date: _____ Evaluator: _____

3. **Ensure communication documentation procedures are followed in the event of an emergency situation.**

- Incident within an incident
- Emergency messages

Completed Date: _____ Evaluator: _____

4. **Review the County Communications Plan, any ICS 205 or 217, with incident personnel as necessary**

Completed Date: _____ Evaluator: _____

5. **Identify and prioritize incoming information and determine appropriate response.**

Completed Date: _____ Evaluator: _____

6. **Ensure radios in use by unit or incident personnel are operational.**

- Tag non-functioning equipment.
- Clone or program radios as necessary.
- Recognize basic communications systems malfunctions (e.g., intermittent repeater transmissions, dead spots, poor quality audio, off-frequency) and alert Radio Technician, EC, or immediate supervisor.
- Order needed supplies (e.g., batteries, forms).

Completed Date: _____ Evaluator: _____

ARES Member Name and Call Sign: _____

Reviewed and Approved for Certificate EC: _____

ARES/RACES EC Skills-based Task List

(Tasks Required in Addition to Radio Operator and AEC for Ops. Tasks, IS800, IS802, IS300, enroll in COML or equivalent)

1. **Establish and maintain positive interpersonal and interagency working relationships.**
 - Get to know the EM, served agency personnel and regional telecommunications professionals with whom you will be working, and establish close working relationships before an incident occurs.

Completed Date: _____ DEC: _____

2. **Evaluate needs, materials, personnel, and training to keep unit operating effectively.**
 - Obtain equipment, materials and supplies required for the unit mission
 - Maintain quantities of supplies and materials at a level to prevent shortage of any basic needed items.
 - Ensure adequate personnel to support the unit; technicians, radio operators, etc.
 - Coordinate with the served agencies for any or additional interoperability resources that may be needed.
 - Assess current tactical communications equipment needs such as power sources, portable antennas and logistics support for extended operations.

Completed Date: _____ DEC: _____

3. **Organize and supervise unit.**
 - Brief and keep subordinates informed and updated.
 - Establish unit time frames and schedules.
 - Assign and monitor work assignments.
 - Develop team work.
 - Provide counseling and discipline as needed.
 - Brief relief personnel.

Completed Date: _____ DEC: _____

4. **Participate in served agency and area planning meetings as the technical expert for amateur radio emergency backup communications capability; coordinate with other communications professionals to share information and assure communications interoperability**
 - Determine the feasibility of providing the required communications support.
 - Provide operational and technical information on equipment available to the served agency.
 - Provide operational and technical information on communications equipment and systems capabilities and limitations.

Completed Date: _____ DEC: _____

5. **Coordinate frequencies, activities, and resources with communications professionals elsewhere.**
 - Contact adjacent county EC's and communications coordinators, and notify them of incident frequency and other shared resource assignments, as appropriate.
 - Provide a copy of the unit Comm Plan/ICS Form 217 to other agencies or to the EC and/or COML at any nearby locations as necessary to avoid interference.
 - Ensures that the Section On-Line County Unit Communications Plan is kept current.

Completed Date: _____ DEC: _____

Reviewed and Approved for Certificate DEC: _____

Training Topics:

Winlink System Design:

Objective: Attendees will understand the fundamental elements and how they work together to form the Winlink system. Presentation will cover the theory and practical implementation of the Winlink system. Specifics on the various equipment and network structure will be covered. RMS and CMS functions will be explained. Various diagrams will facilitate understanding of this communications system. Demonstration of Telenet, VHF Packet, HF Pactor and possibly HF Winmor will be demonstrated.

RMSExpress Basics – Telnet:

Objectives: Attendees will understand the basics of RMSExpress and its fundamental usage to compose, send and receive Winlink messages using the Internet (Telnet).

Basics – installing and configuring software for Telnet

Contacts – entering, maintaining and exporting/importing.

Message composing, posting, receiving and sending

Proper construction of subject line for OEM Messages

Using OEM e-mail templates ICS 213 OEM (Oregon Emergency Management) templates

White list considerations and management of White List

Use of RMS (Remote Message Server) and Peer to Peer modes, position reports using Long/Lat

BBS and keyboard modes, automatic mail checking

Using RMSExpress as a dumb terminal to configure a TNC (Terminal Node Controller)

RMSExpress Intermediate – Telnet, VHF/UHF, HF:

Objectives: Attendees will understand the basics of RMSExpress, contacts, templates and OEM Subject line construction. Using VHF packet and HF Pactor will be covered and demonstrated.

Installing and configuring software for Telnet, VHF Packet and HF Pactor

Using Contacts – entering, maintaining and exporting/importing and management of group lists

Proper construction of subject line for OEM Messages

Composing, posting, receiving and sending e-mail including OEM templates

Replying to e-mail and OEM messages

White list considerations, attachments, updating and using OEM templates

Use of VHF RMS and Peer to Peer modes will be explained and demonstrated

BBS and keyboard modes, automatic mail checking

Automatic Winlink forwarding to another address

Use as dumb terminal to configure TNC (Terminal Node Controller)

Viewing propagation information for HF RMS stations

Use of Nodes and out of County VHF/UHF RMS stations

Performance considerations with various modes

RMSExpress Advanced – Telnet, VHF/UHF, HF and Peer-To-Peer:

Objectives: Participants will be familiar with all necessary aspects of RMSExpress to independently compose, receive and send OEM template messages in an EOC.

Installing and configuring software for Telnet, VHF Packet and HF Pactor

Procedures for updating the HF Remote Message Server catalog (both public and EMCOMM)

Quarterly OADN testing and reporting procedures

Using Contacts – entering, maintaining and exporting/importing and management of group lists

Proper construction of Airmail subject line for OEM Messages

Composing, posting, receiving and sending e-mail
Replying to e-mail and OADN messages
White list updating and reporting
Appropriate use of attachments – sending and receiving
Practice with all OADN message templates
Use of HF Peer to Peer modes, VHF peer-to-peer
Examination of Log Files
BBS and keyboard modes, automatic mail checking
Automatic forwarding to another address
Dumb terminal to configure Terminal Node Controller (TNC)
Viewing propagation information for HF
Advanced use of Nodes and out of County VHF/UHF RMS stations
Performance considerations with various modes

Jump Kit Preparation:

Objective: Each participant will know how to prepare an appropriate jump kit. A complete discussion of the importance of preparedness kits and their contents will be given. Radio and personal kits are needed. Handouts of items needed for brief and extended jump kits will be distributed. List of suggested and required items will be available. Sample kits will be available. Each potential responder will be encouraged to prepare and maintain a basic preparedness kit. Different kits will be presented for different needs.

Message traffic training using ICS 213, 309:

Objective: Each participant will know the basics of proper message handling using ICS 213 and 309 forms. There will be specific group and individual practice taking and sending messages using simulated FM Voice, Telephone and Winlink. Members with Winlink installed on their laptops are encouraged to bring the laptops to the training and Wi-Fi will be available. Practice will be done with the multipart ICS 213 and the 8 X 11 format.

Task Book Certification Training:

Each ARES unit is required to provide training leading to certification of all members for some basic skills. Training will be offered for certifications for Radio Operator, Operations Assistant Emergency Coordinator, Emergency Coordinator and Communications Technician after general monthly meetings. Use of ICS 213 General Message Form, ICS 309 Communication Log, ICS 214 Unit Log, ICS 205 Radio Frequency plan, ICS 217 Radio Frequency Assignment Worksheet and others. Explanations and examples of tactical, emergency and health and welfare traffic priorities.

Emergency Communication:

Objective: Each participant will be able to explain the basic components of emergency communications. Discussion of practical ARES communications plans and strategies in the event of a large scale communications failure (failure of cell phones, land phones, power, Internet. etc.) Topics will cover the use of VHF and UHF simplex (without repeaters as they may fail in a long term power outage). Peer-to-Peer digital will be discussed. The use of HF in conjunction with VUF and UHF will be covered. Plans will be reviewed as how to set up and support emergency communications in support of County Emergency Management.

Hand Held Radio Programming:

Objective: Each participant will be able to program their handheld radio for simplex and repeater use. Participants will bring their hand held radios (with instruction manuals) or use a borrowed radio and participate in programming the radios for various frequencies. Simplex, repeater programming will be

covered. Programming radios for scanning in different circumstances will be covered. Use of various tones will be covered. The goal of the training is for participants to be comfortable adding and changing the programming of their hand held radios to meet Radio Operator Skills based Task list..

IS 100/144/200/700:

Objective: Each participant will know how to take the FEMA on-line trainings, take the exam and print their certificates of completion. This session will assist those wanting to take these on-line trainings. Assistance will include how to access the web sites, how to take the training and print certificates of completion. Each person will take the class as an individual.

Repeaters – overview:

Objective: Participants will understand the basics of repeater operation. This session will present the theory and practical use of VHF/UHF repeaters. It will also present information on the repeaters in our area including frequency, location, coverage, use, tones, etc. Diagrams showing the positions and linking features will be available.

Douglas County ARES Emergency Communications Plan Review:

Objective: Participants will know the basic components of the Douglas County Emergency Communications Plan, how to locate a copy and how to reference the plan elements. This session will review the Douglas County ARES Emergency plan. Each student should review the plan prior to the class. It is important that each ARES member be familiar with the plan and how they can assist in an emergency or training.

Douglas County Emergency Operations Center Operations:

Objective: Participants will be familiar with each radio and electronic component of the EOC and be able to explain its function. Participants will review the role of ARES in the operation of the County Emergency Operations Center in Roseburg. Discussion of the procedures and equipment will precede a tour of the communications facility. Hands on training will be provided in the use of the phones, UHF/UHF voice, Winlink - RMSExpress (Packet, Telnet and HF). Use of Satellite Internet, printers and Wi-Fi in the facility will be covered. Use of ICS 213 and 309 forms will be covered. Specific training for the radios in the center will include the Yaesu 8800, Yaesu 8000, ICOM 718, 2200H and 2820.

Western Douglas County Operations Center (Reedsport) Operations:

Objective: Participants will be familiar with each radio and electronic component of the EOC and be able to explain its function. Participants will review the role of ARES in the operation of the WDCOC. Discussion of the procedures and equipment will precede a tour of the communications facility. Hands on training will be provided in the use of the phones, IP phones, UHF voice, Winlink (using RMSExpress, VHF Packet, Telnet and HF). Use of printers, Satellite Internet and Wi-Fi in the facility will be covered. Use of ICS 213 and 309 forms will be covered. Specific training for the radios in the center will include the ICOM 718, 2200H, 2820 and others. There will be a discussion of the operation of the propane powered generator backup system.

Set up and operate Incident Communications trailer:

Objective: Participants will be familiar with the basic operation of the unit and be able to assist in its operation under supervision. Participants go to the Douglas County Facility and review the operation of the Incident Command Communications Trailer. Take the trailer to a possible site and set it up and operate all of the equipment. Take site down and return to storage. Follow check list – check tires, test generator, heat/air, all radios, connections, manuals, and other aspects of unit.

Winmor RMS Express Training – HF radio:

Objective: Participants will understand the basic concepts of RMS Express software and its use with HF radio digital communications. Participants travel to a site (probably the Roseburg Emergency Operations Center or the Western Douglas County Operations Center) to see how Winmor and RMS Express are used. See the system in operation. Members with appropriate equipment will have to bring their personal equipment to the site to demonstrate and train as neither facility has the hardware or software installed to operate Winmor.

WSPR – (Weak Signal Propagation Reporting) – HF radio - Introduction:

Objective: Participants will understand the basics of WSPR. A PowerPoint presentation will overview and detail WSPR operations and cover the software and web sites utilized. Participants will visit a site (probably the Roseburg Emergency Operations Center or the Western Douglas County Operations Center or an Official Emergency Station) and learn about WSPR and see it in operation

SAR (Search and Rescue) Repeater Training, maintenance and deployment:

Objective: Participants will understand the basics of setting up, maintaining and deploying the SAR Repeater. Training will be hands on and include setting up, maintaining and deploying the Search and Rescue portable repeater and field antenna system. The portable repeater system will be utilized in the training.

Visiting the Douglas County Dispatch Center (911):

Objective: Participants gain better understanding of the functioning of the dispatch center and how ARES members may assist in a communications event. Presentation by dispatch personnel as to how the center operates and how members may be asked to assist in communications emergencies. A tour of the center will follow the presentation.

Antenna Design and Testing:

Objective: Participants will gain insight into antenna design and how to test antennas. Presentation about how to design antenna systems and how to test for proper operation. Use of ARES antenna analyzer will be demonstrated.

Anderson Power Poles:

Objective: Attendees will understand 30amp power pole technology, usage, assembly and the importance of a universal radio power connection. Presentation with hands on items will explain how this electrical connection technology is used. Anderson Power Poles are the national ARES standard.

Fox Hunt – ELT (Emergency Location Transmitter):

Objective: Participants will understand the fundamental principles of ELT and locating a transmitter using VHF handheld radio. Presentation on the theory and practical use of radio equipment to assist in the location of an ELT. A practice session will be scheduled using a VHF unit.

Telephone Call Down Review:

Objective: Attendees will understand the procure for Douglas County ARES telephone call down to determine availability, place members on alert, standby and to deploy. Presentation detailing the Douglas County Emergency Call Down procedures. Notification of members for availability and deployment may occur even if there is no apparent emergency that would need VHF radio check in.

Ham equipment grounding principles:

Objective: Attendees will understand the basics of proper radio grounding, both electrical and RF grounding. This important aspect of radio equipment will be covered. Materials will be based on several published articles in QST magazine and include practical steps that every operator should take to assure proper electrical and RF grounding for their stations.

ORSDF (Oregon State Defense Force) – function and support:

Explanation of the Oregon State Defense Force and how it operates and can what resources it can offer.

Quarterly Reports:

Objective: Participants will learn the procedures to test the EOC radio equipment and produce the required reports to EOM. Actual EOC equipment will be used in this training.

Search and Rescue Support:

Objective: Participants will learn what kinds of tasks they can perform to support a Search and Rescue operation. There are several tasks that ARES members can perform. Some are in the field, some in the Command Trailer and some in other locations.

Incident Command Trailer:

Objective: Participants will learn about the radio equipment in the trailer and how it can be used to support field operations. Participants will have a chance to tour the trailer.

Basic Mapping and GPS for ARES Members

Objective: Participants will have a basic understanding of how GPS works, basic map reading use of coordinates including Lat/Long and UTM as they relate to ARES supporting Search and Rescue operations.

Douglas County River and Stream Gauges

Objective: Participants will have materials showing the locations of river and stream gauges in Douglas County. They will understand how to navigate to these locations and take level readings. This is important in the event of filed reporting systems and manual readings are necessary.