

KRENDL

Fiber Moving Equipment



OWNERS MANUAL MODEL #425



50 YEARS OF QUALITY AND SERVICE

KRENDL MACHINE COMPANY • 1201 SPENCERVILLE AVE
DELPHOS, OHIO 45833 • TELEPHONE 419-692-3060 • FAX 419-695-9301
E - MAIL: krendl@krendlmachine.com • WEB SITE: www.krendlmachine.com

CONGRATULATIONS ON YOUR PURCHASE OF KRENDL EQUIPMENT

**MODEL #425
OWNER'S MANUAL**

FOR ASSURED SAFETY AND CONFIDENCE, PLEASE READ THIS MANUAL CAREFULLY BEFORE INSTALLING AND OPERATING YOUR MACHINE.

**E-MAIL ADDRESS IS: krendl@krendlmachine.com
WEB SITE IS: www.krendlmachine.com**

Table of Contents

	PAGE
INTRODUCTION.....	1
GENERAL SAFETY INFORMATION.....	2-3
DECALS.....	4-5
WARRANTY.....	6
RETURNED GOODS PROCEDURE and SPECIFICATIONS	7
BASIC COMPONENTS.....	8
OPERATING INSTRUCTIONS.....	9
GENERAL MAINTENANCE.....	10-12
TROUBLESHOOTING.....	13
ELECTRICAL.....	14-18
LADDER DIAGRAM.....	19-22
PARTS LIST.....	23-26
GLOSSARY.....	27
SERVICE RECORD.....	28

INTRODUCTION

Thank you for purchasing a **KRENDL FIBER MOVING MACHINE**. With over fifty years experience in manufacturing fiber moving equipment, we have designed and built your machine with the highest quality to provide years of reliable service.

This manual has been prepared to help you obtain the maximum efficiency and service from your Krendl equipment. The machine is designed to condition and apply fibers with the utmost in dependable performance. Our primary objective is to build equipment which will provide complete satisfaction so that you may confidently recommend Krendl to others.

We do not manufacture or sell fibers. Our interest lies only in the proper performance of the equipment we manufacture. We make no recommendations or guarantees concerning various fibers.

CAUTION:



This manual contains important information regarding the **safe** assembly and operation of your machine. We urge you to read it carefully and follow the instructions provided. If your questions are not answered in this manual, may we hear from you? We want you to be able to operate this unit safely and confidently.

UNPACKING: Store and unpack carton with correct side up. Unpack your machine **IMMEDIATELY** and check for damage in shipping. **Place any damage claim with delivering carrier, saving all packing materials for inspection.** Our warranty covers manufacturer's defects only. **DO NOT** return to shipper.

FILL IN AND RETAIN:

Krendl Machine Company
1201 Spencerville Ave.
Delphos, Ohio 45833 U.S.A.

Telephone: 419-692-3060
Fax: 419-695-9301
E-mail: krendl@krendlmachine.com
Web Site: www.krendlmachine.com

For your protection in the event of theft or loss, please fill in the information requested for your own records. This information will be needed for in-warranty repairs. You may also want to attach a copy of your invoice.

Machine model number _____ Blower motor manufacturer _____
Serial number _____ Gear motor manufacturer _____
Blower(s) serial number(s) _____ Gear motor serial number _____
Supplier _____ Date of purchase _____

The model and machine serial numbers are located on the hopper of the machine unit. The blower and gearmotor serial numbers are located on the motor housing of each unit.

GENERAL SAFETY INFORMATION

 **Important:** Read **all** instructions **before** operating this unit. This equipment can be potentially dangerous and must be used in strict accordance with instructions.

 **Disclaimer Notice:** The manufacturer will not be legally responsible for any injury or damage resulting from the improper use of this equipment or the failure to follow instructions.

Unpacking

Handle cartons with care to avoid damage from dropping or bumping. Store and unpack cartons with the correct side up. Completely remove machine from the packaging and from any shipping pallet or skid to which it might be attached. In addition, completely remove all shipping materials from **inside** the machine including wheel package, manual, ect....



General Safety

1. Read this manual carefully and become familiar with your machine unit. Know its applications, limitations, and any hazards involved.
2. This machine was designed and manufactured for specific applications. Do not attempt to modify the unit or use it for any application it was not designed for. If you have any questions about your intended use or the machines suitability, ask your dealer/distributor or consult the factory. The manufacturers' could not possibly anticipate every circumstance that might involve a hazard. For that reason, warnings in the manual and warning tags or decals affixed to the unit, are **not** all-inclusive. If you intend to handle, operate, or service the unit by a procedure or method not specifically recommended by the manufacturer, first make sure that such a procedure or method will not render this equipment unsafe or pose a threat to you and others.



Electrical Safety

- The **National Electric Code** (NEC) in the United States and many international electrical codes require frame and external electrically conductive parts of this machine to be properly connected to an approved earth ground. Local electrical codes may also require proper grounding of machine. Consult with local electricians for grounding requirements in your area.
- Never handle any kind of electrical cord or device while standing in water, while barefoot or while hands or feet are wet. Dangerous electrical shock will result.
- Use a ground fault circuit interrupter (GFCI) in any damp or highly conductive area. (metal decking or steel work)
- Reference NFPA 79, 70E, or OSHA safe work practices when performing energized work procedures.



Safety/Caution

- **Be Safe** - Keep away from moving parts.
- **Be Safe** - Make sure all guards and hopper bar are in proper place **before** operating machine. Hands should **never** pass below hopper bars.
- **Be Safe** - Do not remove motors or lift hopper when unit is connected to power supply.
- **Be Safe** - Make sure machine is properly grounded. Protect all electrical supply cords from sharp objects, moisture, and other potentially hazardous materials. Keep power cords in good repair. Electrical service must be performed by a qualified electrician.
- **Be Safe** - Disconnect power supply **before** inspecting or adjusting unit.
- **Be Safe** - Consult a qualified technician to answer questions **before** attempting to operate, or injury may result.
- **Be Safe** - Wear an **approved** dust mask or respirator for operator comfort and protection.



Make Sure!

- Hopper is empty of foreign objects **before** starting.
- Adequate electrical power is supplied or damage to unit will result.
- Blower filter is kept clean and in place when blower is on.
- Machine is turned off **immediately** if hose is plugged, or blower will overheat.
- Machine must be on **before** adding fiber.
- Blower must be on, when agitators are running, or machine will bind.
- Agitator motor is not run with hopper empty for more than a few minutes, or damage to seals will result.
- Sprockets and chains are correctly **aligned** and **tensioned**.
- Pieces of bag are **not** left in the machine as this can bind and stall your machine.

DECALS



Keeping the filter clean will result in longer blower life and better performances.



Rotating parts can be dangerous! You can snag clothes, skin, hair, hands, etc. This can cause serious injury or death.



Manufacturer information is provided here along with machine model, and serial number.



Specifies the input power of the machine.



Emergency stop button for machine.

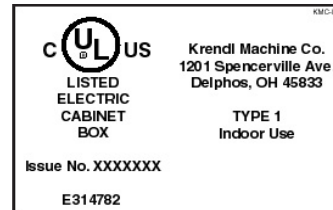

Indicates that the electrical box on the machine is in compliance with UL codes.



Rotating parts will be moving in this direction.



Identifies position of material feed gate.



Part number for identification and tracking.

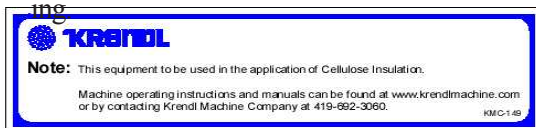

Machine should be used with these products.



Reset button for motor.



General safety information intended to reduce the risk of serious injury or death

Model 425 All-Fiber Machine

OPERATING INSTRUCTIONS

- Read all safety and operating instructions before operating this unit.
- This unit comes ready for connection with hoses, clamps, power cords, and accessories (supplied separately).
- This unit provides a check hook-up to 1" (2.54 cm) ID hose. Slide hose on blower outlet and secure with a hose clamp to provide safe working conditions. All hose connections should have hose clamps to prevent air leakage and separation of hose.
- Air hose and power should be supplied to machine at all times. Should machine need 220V power supply from each input cord should be connected to (2) individual breakers or power supplies. WHEN USING EXTENSION CORDS, WIRE GAUGE SIZE SHOULD NOT BE LESS THAN #12-2 AND NOT EXCEED 50' IN LENGTH.
- When assembling unit, make sure all controls are in OFF position. Hook up electrical supply. Follow instructions below for machines with remote control (SECTION A) or without remote control (SECTION B).
- This machine is equipped with an emergency stop button for your safety. This button must be pulled out and the start button must be pressed for the machine to start.

SECTION A (with remote control)
This unit has a separate electrical panel that has three positions as follows. (NOTE: This panel will be referred to as the CONTROL PANEL and the toggle switch at the end of the remote cord as the REMOTE CONTROL SWITCH.)

LEFT POSITION	CENTER POSITION	RIGHT POSITION
REMOTE	OFF	BLOWER ON

Remote Control operates the BLOWER MOTOR as well as AGITATOR MOTOR. (Blow frequently used.)

A Manual Operation Switch is located on the right side of control panel. Flip switch to ON position to run machine without Remote Control Switch. NOTE: Units with variable blower control turn knob to on position.

SECTION B (without remote control)

LEFT POSITION	CENTER POSITION	RIGHT POSITION
MANUAL	OFF	BLOWER ON

Operates the BLOWER MOTOR as well as AGITATOR MOTOR.

- The first bag of material into hopper should not be broken by right to avoid agitate action. CAUTION: Hopper door MUST be in place when loading hopper. NEVER put hands into or close head material by pushing down on insulation.
- If hopper with insulation and adjust SLIDE GATE. Open SLIDE GATE to allow flow to drop into the arfock, providing good production, but not beyond point where hose plugs. As hose length is increased, the SLIDE GATE should be closed proportionally.
- At the end of the workday, empty the hopper. BLOW OUT THE HOSE with the machine and clean filter.

TROUBLESHOOTING

IMPORTANT! DO NOT attempt to service unit. (Contact your dealer for further information.)

- If machine does not run:
 - Make sure emergency stop button on CONTROL PANEL is pulled out and start button is pressed.
 - Check manual reset button on circuit breaker. Press to reset.
 - Check REMOTE CONTROL CORDS for broken connections.
 - Switch blower motor toggle on CONTROL PANEL to right position, ON.
 - Check power cords for proper connection.
- Load knocking sound:
 - UNPLUG power supply. Check machine agitate on and at block for foreign objects.
 - UNPLUG power supply. Check for misaligned sprockets or loose chain.
- Poor output from machine or uneven flow through hose:
 - Open SLIDE GATE to increase material output.
 - Units with variable speed BLOWER CONTROL, turn BLOWER CONTROL up.
 - UNPLUG power supply. Check for material binding in hopper.
 - Low voltage, try another electrical source. Proper wire size for extension cord (#12-2 wire).
 - UNPLUG power supply. Check for worn or damaged rubber arfock seals.
- Too much dust or open flow:
 - Open SLIDE GATE to increase material output.
 - Units with variable speed BLOWER CONTROL, turn BLOWER CONTROL down.
- BLOWER MOTOR running hot:
 - UNPLUG power supply. Clean filter. Blow out surrounding area with air hose.
 - UNPLUG power supply. Check for restriction in blowing hose.
 - UNPLUG power supply. Check for buildup of fiber around blower.
- AGITATOR MOTOR running hot:
 - UNPLUG power supply. Check for fiber buildup around motor and blow out with air hose.
 - Low voltage can cause this condition. Try another electrical source (#12-2 wire).
 - UNPLUG power supply. Double agitate block. Rotate arfock manually and clean out.
 - UNPLUG power supply. Check for sprocket misalignment and bearing wear.

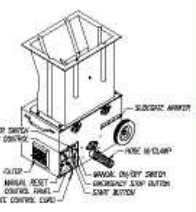

REV 2. KMC-127

Operating and troubleshooting instructions provided here.



Made in the U.S.A.



Manual switch (Bypasses remote)

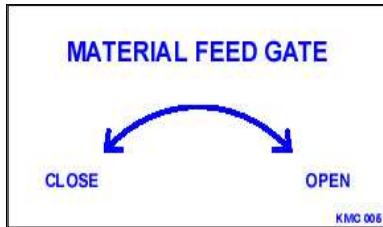

Opens and closes the material feed gate which in turn controls the production.



Indicates if blower is off, on, or on with agitator.



Indicates which employee inspected equipment and on what date.



Indicates this unit has two power sources that should be disconnected before servicing to reduce the risk of serious injury or death.

WARRANTY:

Krendl Machine Company (Company) warrants to each original purchaser (Buyer) of its equipment or accessories that such products will be free of manufacturing defects for a period of 12 months from the date of shipment to the Buyer.

No warranty is made with respect to:

1. Components or accessories manufactured and warranted by others. Warranties for purchased component parts as supplied from vendor such as engine, electric motor, blower, gearbox, transmission, etc., if furnished by the manufacturer of the component, are on file at the Company's main office and copies will be furnished at request of Buyer. Component(s), shipping costs prepaid, shall be sent to Company who in turn shall forward to vendor for evaluation and warranty determination.
2. Any defect caused by repair, alteration and/or adjustment performed by Buyer or customer/vendor of Buyer without the express written authorization of the Company.
3. The labor costs of replacing parts by parties other than the Company.
4. Any machine that has not been operated and/or maintained in accordance with normal industry practice and the written recommendations of the Company. (e.g. machine operated with an improperly sized, worn or damaged hose, improper or inattention to preventative maintenance, etc.)
5. The product has been subjected to misuse, negligence or accident or results of any application or use of the blowing equipment not in accordance with the Company recommendations.

This limited warranty does not cover the free replacement of component parts that become inoperative due to wear and usage and need to be replaced on a regular basis, including but not limited to: airlock seal(s), agitator(s), shredder(s), auger(s), fuse(s), switch(es), clutch(es), hose(s), shaft seal(s), chain(s), belt(s), sprocket(s), pulley(s), bearing(s), cable(s), battery(ies), filter(s), fan(s), etc.

The Company's obligation under this warranty is limited to repairing or replacing (at Company option) any part that is determined by the Company to be suffering from a manufacturing defect. The Company (at Company option) will provide any required parts and labor to the Buyer. If the equipment or parts must be returned to the Company for repair, all transportation costs shall be the Buyer's responsibility.

This limited warranty is expressly in lieu of any other guarantees and / or warranties, oral or written, expressed or implied, including without limitation, the implied warranty of merchantability. No warranty, express or implied, other than the aforesaid warranty is made or authorized by Company. Company shall not be liable for any direct, indirect, incidental or consequential damages to property or injury to any person or costs associated with loss of production resulting in loss of revenue, profits or loss of equipment through the use of this equipment.

Note: Special job circumstances incurring costs for specialized repair and next day delivery of parts will not be reimbursed by the manufacturer unless authorized by factory.

RETURNED GOODS PROCEDURE:

IF MACHINE WAS NOT PURCHASED DIRECTLY FROM KRENDL MACHINE COMPANY, CONTACT YOUR SUPPLIER / DISTRIBUTOR.

When returning products to Krendl for repair, first obtain a return goods authorization, at which time you will be given shipping instructions. The product must be shipped **PREPAID**:

Krendl Machine Company
1201 Spencerville Ave.
Delphos, Ohio 45833 U.S.A.

Telephone: 419-692-3060
Fax: 419-695-9301
E-mail: krendl@krendlmachine.com
Web Site: www.krendlmachine.com

Once the unit is received, it will be inspected. In-warranty units will be repaired and returned immediately. An estimate of repair charges will be provided for out-of-warranty units.

SPECIFICATIONS

MODEL#:	425 (Single Input)	425 (Double Input)
HEIGHT:	44"	44"
WIDTH (DEPTH):	36"	36"
LENGTH:	21"	21"
WEIGHT:	196 pounds	196 pounds
ELECTRICAL:	120VAC, 15 amp, S.I.	120VAC, 15 amp, D.I.
BLOWER VOLUME:	104 CFM	94 CFM
BLOWER PRESSURE:	2.0 PSI maximum	3.0 PSI maximum
HOSE OUTPUT:	2.5" diameter	2.5" diameter

MAXIMUM FEED RATES:

CELLULOSE: 1200 lbs./hr.

FIBERGLASS: 300 lbs./hr.

WARNING: Recommended hose size, type and length must be used to achieve maximum results. Krendl cannot guarantee performance of the machine if hoses are undersized, worn, damaged, or hoses other than those we recommend are used.

BEFORE YOU RUN THIS MACHINE...PLEASE READ THE REST OF THIS MANUAL!!

BASIC COMPONENTS: #425

This is a view of the basic components of your #425 machine. It shows the location of each item and gives the function of each. Use this as a guide throughout the manual.

- A) **BASE UNIT** — Lower frame unit supporting blower, gearmotor, airlock and hopper.
- B) **AIRLOCK** — Traps air and fiber while providing a metered flow.
- C) **GEAR MOTOR** — Provides driving power of agitation system. Increases output power while decreasing speed of the agitators and airlock.
- D) **BLOWER** — Creates air pressure to blow fiber out of airlock.
- E) **AGITATORS (2)** — Conditions fiber in the hopper.
- F) **HOPPER** — Upper unit of machine holding fiber.
- G) **HOPPER BAR** — Hinders operators from reaching agitators.
- H) **MAIN CONTROL PANEL** — Connects with main power, allowing operation of unit at machine.
- I) **EMERGENCY STOP BUTTON** — Safety device for immediate stopping of machine. (Located on electrical box)
- J) **SLIDEGATE** — Meters the amount of fiber dropping into airlock by controlling size of airlock opening

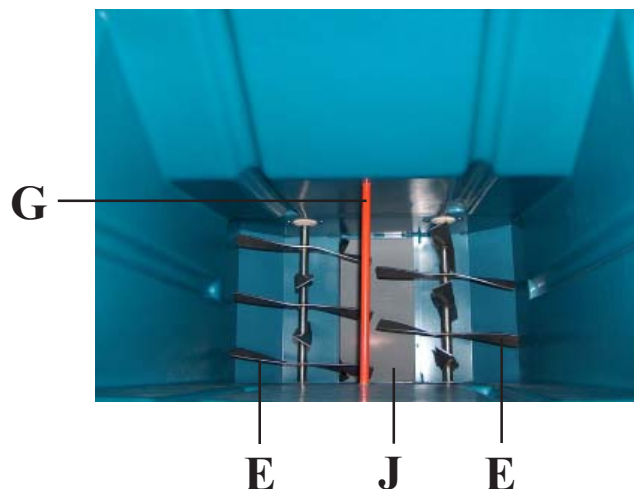
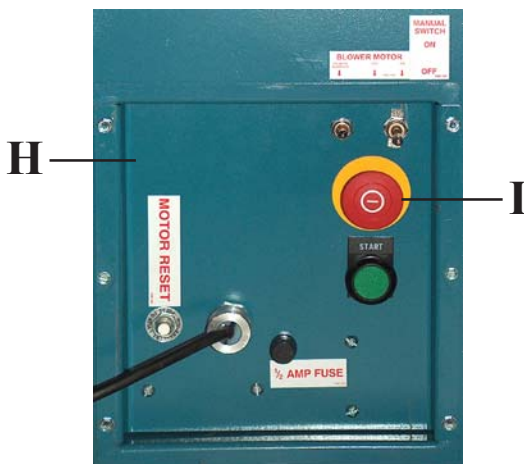
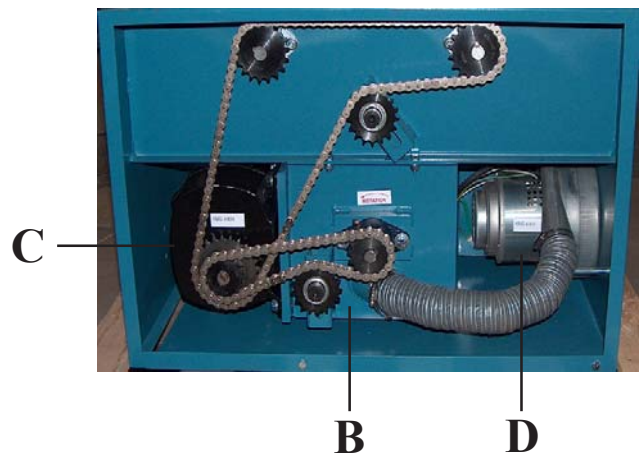
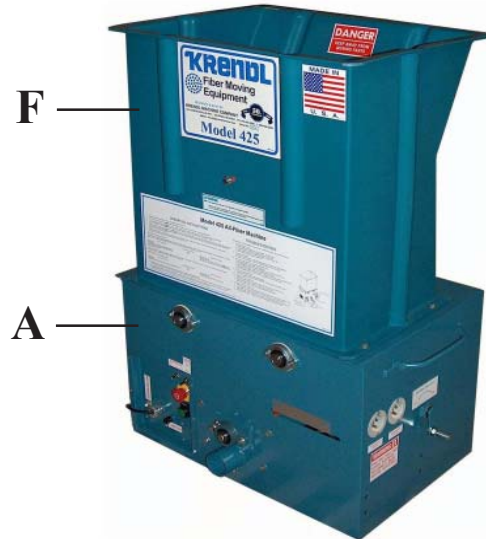

OPERATING INSTRUCTIONS

1. Read all safety and operating instructions before operating this unit.
2. This unit comes ready for connection with hose, clamps, and power cords, and accessories.
3. This unit provides a direct hook-up to 2 1/2" I.D. hose. Slide hose on blower outlet and secure with a hose clamp to provide safe working conditions. All hose connections should have hose clamps to prevent air leakage and separation of hose.
4. This unit can be supplied with power through (2) **INPUT CORDS** that connect to (2) individual breakers or power supplies. **WHEN USING EXTENSION CORDS, WIRE GAUGE SIZE SHOULD BE AT LEAST #12-3 AND NOT EXCEED 50' IN LENGTH OR #10-3 AND NOT EXCEED 100' IN LENGTH.**
5. When assembling unit, make sure all controls are in **OFF** position. Hook up electrical supply. Follow instructions below for machines with remote control (**SECTION A**) or without remote (**SECTION B**). **NOTE:** Input cords must be supplied with power from two separate sources for the unit to work properly.
6. This machine is equipped with an emergency stop button for your safety. This button must be pulled out and the start button must be pressed for the machine to start.

SECTION A (with remote control)

This unit has a separate electrical panel that has a three position switch as follows: (**NOTE:** This panel will be referred to as the **CONTROL PANEL** and the toggle switch at the end of the remote cord as the **REMOTE CONTROL SWITCH**.)

LEFT POSITION
REMOTE

Automatic side of switch which operates the **BLOWER MOTOR** on with **AGITATOR MOTOR** with the remote control switch. (Most frequently used.)

CENTER POSITION
OFF**RIGHT POSITION**
BLOWER ON

Manual side which operates the **BLOWER MOTOR** continuously while operating the **AGITATOR MOTOR** with remote control switch.

A Manual Operation Switch is located on the right side of control panel. Flip switch to **ON** position to run machine without Remote Control Switch. **NOTE:** Units with variable blower control turn to on position.

SECTION B (without remote control)**LEFT POSITION**
MANUAL

Operates the **BLOWER MOTOR** on with **AGITATOR MOTOR**

CENTER POSITION
OFF**RIGHT POSITION**
BLOWER ON

Manual side operates the **BLOWER MOTOR** continuously.

7. The first bag of insulation in the hopper should be well broken by hand to assist agitator action. **Note:** Hopper bars **MUST** be in place while loading hopper. **Caution: NEVER** put hands below bars or force-feed material by pushing down on insulation.
8. Fill hopper with insulation and adjust **SLIDEGATE**. Open **SLIDEGATE** to allow fiber to drop into the airlock providing good production, but not beyond point where hose plugs. As hose length is increased, the **SLIDEGATE** should be closed proportionally.
9. At the end of the workday, empty the hopper and **BLOW OUT THE HOSE** with the machine.

GENERAL MAINTENANCE

Periodic preventive maintenance will add years of life to your equipment. Reviewing the information in this manual will go a long way in reducing downtime. **Remove hopper** for easy maintenance of lower base unit.

⚠ KEEP CLEAN: During operation, keep material from accumulating on Blower Filter. Always keep Filter in place while operating machine. After each use, remove fiber from hopper and blow out hose.

AIRLOCK:

SEAL REPLACEMENT: The purpose of the airlock seal is to trap air and fiber until it rotates 180° to the 6:00 o'clock position. At this point, fiber is pushed by air from the blower, out of the chamber. Worn or damaged seals allow air and fiber to escape back into hopper, thus reducing production and coverage. When it is necessary to replace seals, follow these directions:

Airlock rotor plates that are damaged (bent) will need replaced. (Refer to Rotor Replacement below.) Take out rubber seal by removing the three plate fastening bolts and top plate. Install new seal. Seal should be inserted tight against the rotor plate, pressing the lower tabs of seal down under the adjacent seal with a flat blade screwdriver. (See Illustration A) Before tightening bolts make sure all bolt holes are aligned while each side of seal is equally pressed against the end plates. Seal should be bent backwards for **counterclockwise** rotation.

ROTOR REPLACEMENT:

1. To check plates for proper angle, measure distance between outer edge of metal plates. (See Illustration A) This measurement should be 2 1/2". Measure all six plates and replace rotor if needed.
2. Remove top plate and seal from rotor. Check seal and top plate for wear and/or damage.
3. Loosen set screws on locking collar of bearings on each side of airlock.
4. Remove chain, sprocket and seven bolts that secure airlock to machine.
5. Remove airlock from machine.
6. Remove old rotor and replace with new rotor.
7. Caulk endplate ring of airlock chamber with silicone. (See Illustration B)
8. Place airlock back into machine and reattach with bolts. Reinstall chain and sprocket. Tighten set screws on locking collar of bearings.
9. Install seal and top plate. As seal and top plate are installed, press bottom tab of seal under adjacent seal with flat blade screwdriver. (See Illustration A)

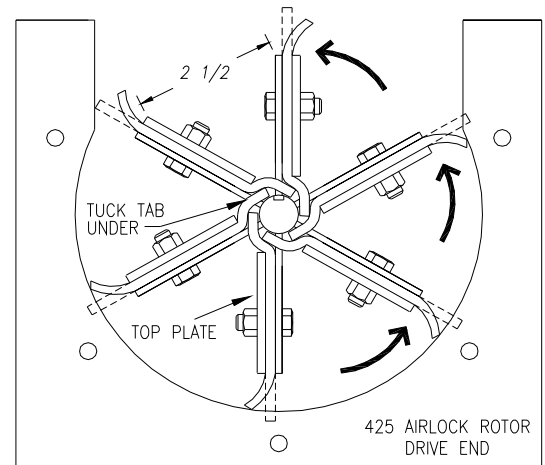

Illustration A

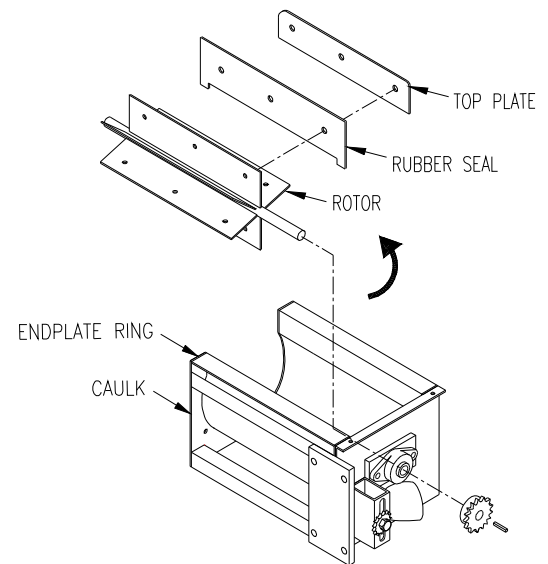

Illustration B

General Maintenance (cont.)

Make sure seal and top plate are assembled on **correct** side of rotor plate before assembling in airlock. Seal should press backward towards top plate when installed correctly into airlock chamber. The airlock runs **counterclockwise** viewing it from the sprocket drive shaft. (See illustration B)



Caution: If installed improperly, damage to seals will result and put undue stress on agitator motor. This causes overheating and poor production. Seal should be bent backward to allow for a **counterclockwise** rotation of rotor.

CHAIN: (#40 Nickel Plated)

ADJUSTMENT: A smooth operating chain drive should have a slight sag on the idler side of the chain. New chains should be installed under slight tension as they will elongate a small amount due to seating of pins and bushings during the first few days of operation. Excessive chain tension or loose chain will cause shortened life of bearings, chain, and sprocket. Chain should be kept in good condition by proper lubrication (dry film lubricant Dow 321) and occasional cleaning. Soaking chain in container of 10 weight oil will provide for internal lubrication of pins and bushings. However, excess oil must be drained and wiped away as excessive lubrication will cause fiber accumulation on chain. Worn out chain should be replaced. When chain is replaced, worn sprockets should also be replaced, preventing further damage to new chain.

SPROCKETS:

CHECK SPROCKETS FOR WEAR. Misalignment and/or loose sprockets and improper chain tension causes the premature wear of chain and sprockets. All sprockets, except the idler sprocket, have been secured with a medium grade Loctite (general purpose thread locker), to prevent gradual movement. The set screws and key are also inserted with a medium grade Loctite. If sprocket is difficult to remove, it may be heated with a propane torch to loosen.



Caution: Do not overheat sprocket or damage to bearing will result. A pulley or bearing puller can then be used to remove the sprocket and key. Replace new sprocket on shaft with key and medium grade Loctite applied to shaft. Align sprocket with corresponding sprocket, using a straightedge placed along face of teeth and tighten set screw. Gearmotor sprocket does **not** require Loctite.

BEARINGS:

AGITATOR BEARINGS in base unit are prelubricated, double-sealed, self aligning ball bearings. **No** lubrication is necessary. If bearings produce noise or heat (*too-hot-to-touch*), replace the bearings.

AGITATOR BEARING REPLACEMENT: Spray area with rust penetrant (WD-40). Remove sprocket (See SPROCKET section above). Remove the two bolts from bearing flange and outer flange from bearing insert. Loosen set screws on bearing hub at each end of agitator shaft. Since all set screws are installed with a medium grade Loctite, a propane hand torch may be used to assist in removing them. Do not overheat unit, causing shaft to expand. Using a rubber mallet, drive agitator shaft an inch in one direction, creating a space between hopper and bearing unit. A bearing puller can then be used to remove the bearing. Eliminate any metal burrs from shaft with file and install new bearings with felt seals. Use a medium grade Loctite on set screws before securing bearing to shaft.

AIRLOCK BEARINGS are prelubricated, double sealed, self aligning ball bearings. Lubrication **is** required at three month intervals of normal running time, or sooner if bearings produce a noise or become *too-hot-to-touch*. Relubrication at the grease fittings is done with a lithium base grease conforming to a NLGI GRADE TWO consistency. The grease should be pumped in slowly until a slight bead forms around the seals. This bead, in addition to acting as an indicator of adequate lubrication, provides additional protection against the entry of foreign matter. **Important:** If a slight bead does **not** form, indicating a failure of lubrication, or if bearing shows signs of wear, replace bearing.

General Maintenance (cont.)

AIRLOCK BEARING REPLACEMENT: Remove two bolts from bearing and follow steps above for agitator bearing replacement.

GEARMOTOR DRIVE:

If drive motor runs hot, or unit does not run properly, refer to troubleshooting sections of manual. The drive motor should start quickly and run smoothly. If not, shut motor off **immediately** and check for low voltage, incorrect power supply, or misconnected wiring which could cause motor failure. **These conditions void the motor warranty.** Overload conditions such as bearing failure, sprocket and chain misalignment, or gear failure in the reducer can be detected by checking the electrical current (amperage) compared with nameplate current (amperage) located on the body of the motor.

GEARMOTOR REPLACEMENT: (See Illustration C) Disconnect power from machine. Remove chain guard and drive chain. Flip base unit upside down and remove bottom guard. Take note of electrical connections and unhook gearmotor drive wires. Loosen hose clamp on rear airlock input tube. Slide hose off airlock. Remove airlock and gearmotor drive assembly out of base. Loosen set screw and take sprocket off gearmotor. Unbolt gearmotor drive from airlock. Install new gearmotor drive on airlock. Reverse procedure for assembly.

BLOWER MOTOR:

Periodically turn machine on its side and vacuum any material that has accumulated around blower motor. Blow out any remaining debris around motor and intake orifice of fan with compressed air. This will extend the life of the blower significantly. Blower filter life can be extended by occasional removing and blowing through with compressed air. Filter should be replaced periodically depending on use. If blower produces noise or heat, refer to troubleshooting section of manual.

BLOWER REPLACEMENT: (See Illustration D) Disconnect power from machine. Remove chain guard. Loosen hose clamp on blower and slide hose off blower. Take note of electrical connections on blower and unhook blower wires. Remove three bolts and spacers from machine and remove blower. Reverse procedure for assembly.

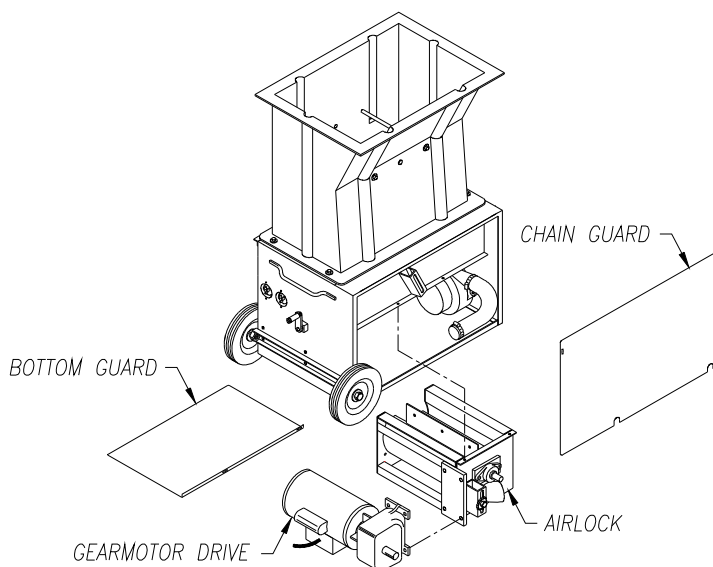

Illustration C

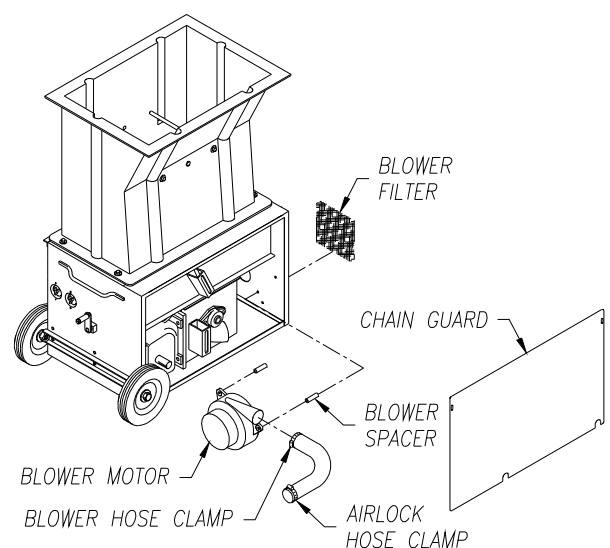

Illustration D

TROUBLESHOOTING

IMPORTANT: DO NOT attempt to service unit. (Contact your dealer for further information.)

1. If machine does not run:
 - a. Make sure emergency stop button on **CONTROL PANEL** is pulled out and start button is pressed.
 - b. Check manual reset button on circuit breaker. Press to reset. (See Illustration F)
 - c. Check **REMOTE CONTROL CORD** for broken connections.
 - d. Switch blower motor toggle on **CONTROL PANEL** to right position, **ON**. (See Illustration F)
 - e. Check power cords for proper connection.
2. Loud knocking sound:
 - a. **UNPLUG** power supply. Check machine agitators and airlock for foreign objects.
 - b. **UNPLUG** power supply. Check for misaligned sprockets or loose chain.
3. Poor output from machine or uneven flow through hose:
 - a. Open **SLIDEGATE**.
 - b. Units with variable speed **BLOWER CONTROL**, turn **BLOWER CONTROL** up.
 - c. **UNPLUG** power supply. Check for material bridging in hopper.
 - d. Low voltage, try another electrical source. Proper wire size for extension cord (#12-3 wire) for 50' or (#10-3 wire) for 100'.
 - e. **UNPLUG** power supply. Check for worn or damaged rubber airlock seals.
4. Too much dust on open blow:
 - a. Open **SLIDEGATE**.
 - b. Units with variable speed **BLOWER CONTROL**, turn **BLOWER CONTROL** down.
5. **BLOWER MOTOR** running hot:
 - a. **UNPLUG** power supply. Clean filter. Blow out surrounding area with air hose. (See Illustration E)
 - b. **UNPLUG** power supply. Check for restriction in blowing hose.
 - c. **UNPLUG** power supply. Check for buildup of fiber around blower.
6. **AGITATOR MOTOR** running hot:
 - a. **UNPLUG** power supply. Check for fiber buildup around motor and blow out with air hose.
 - b. Low voltage can cause this condition. Try another electrical source (#12-3 wire).
 - c. **UNPLUG** power supply. Debris jamming airlock. Rotate airlock manually and clean out.
 - d. **UNPLUG** power supply. Check for sprocket misalignment and bearing wear.

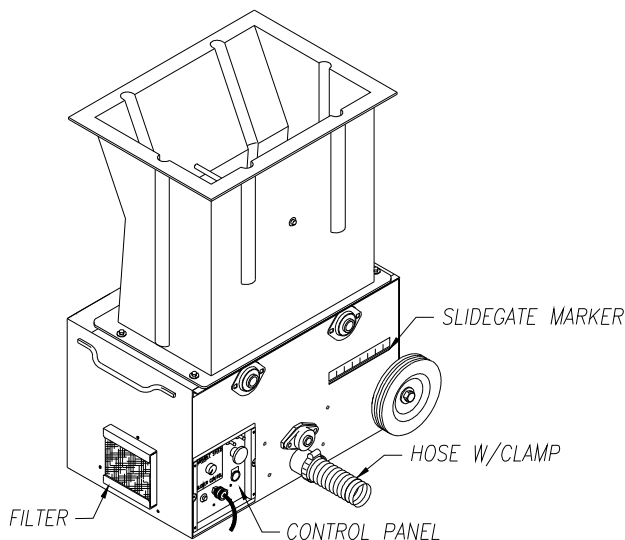

Illustration E

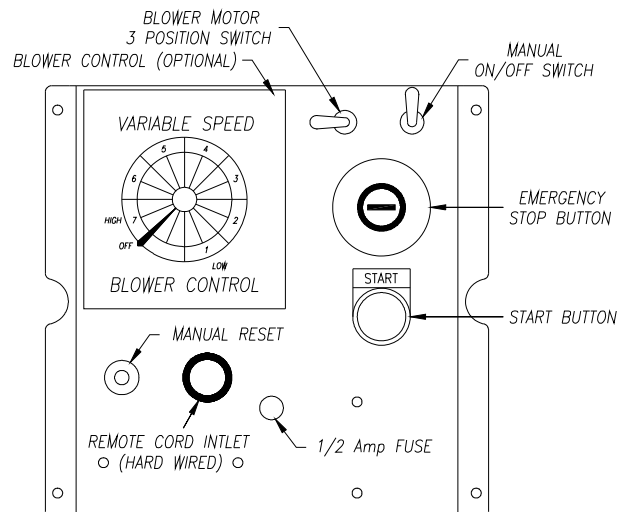

Illustration F

ELECTRICAL

ELECTRICAL DIAGRAM:

Periodically, disconnect machine from power source and check all electrical connections and components for broken or loose wires.

**MODEL #425
120 V.A.C. 60 Hz Single Input
Hardwired W/O Blower Control**

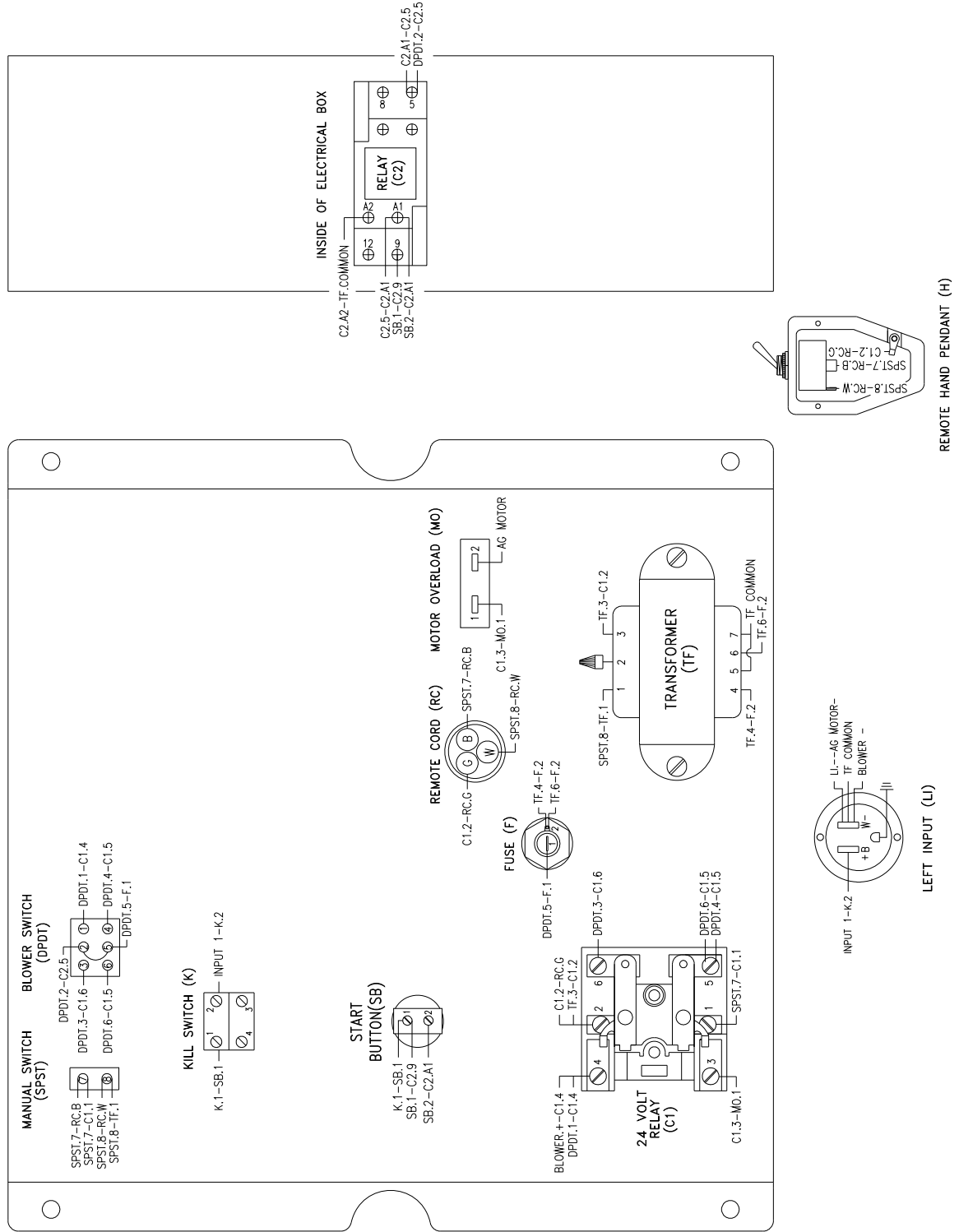

ELECTRICAL DIAGRAM: Periodically, disconnect machine from power source and check all electrical connections and components for broken or loose wires.

MODEL #425
120 V.A.C. 60 Hz Double Input
Hardwired W/O Blower Control

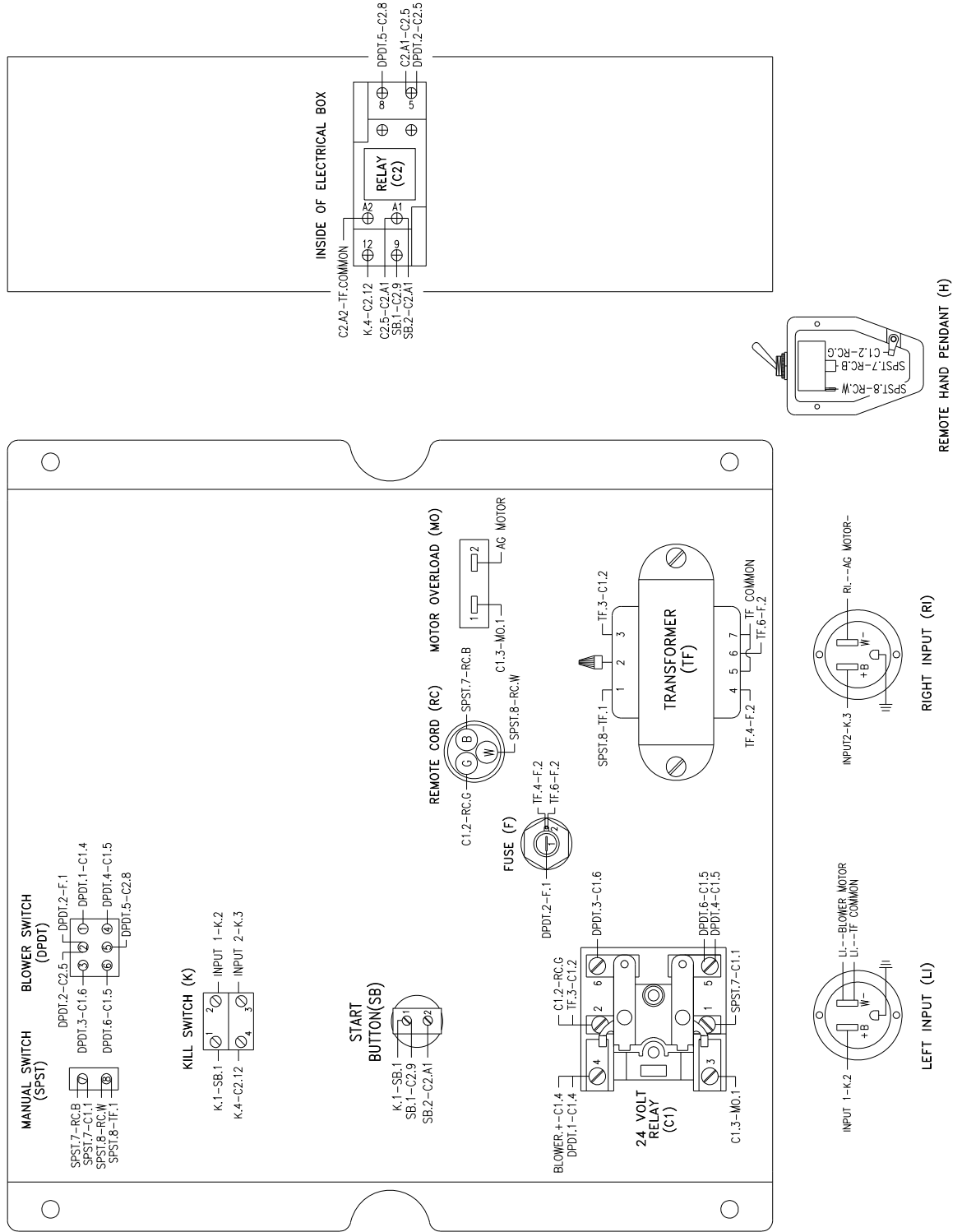

ELECTRICAL DIAGRAM:

Periodically, disconnect machine from power source and check all electrical connections and components for broken or loose wires.

MODEL #425
120 V.A.C. 60 Hz Double Input
Hardwired W/Blower Control

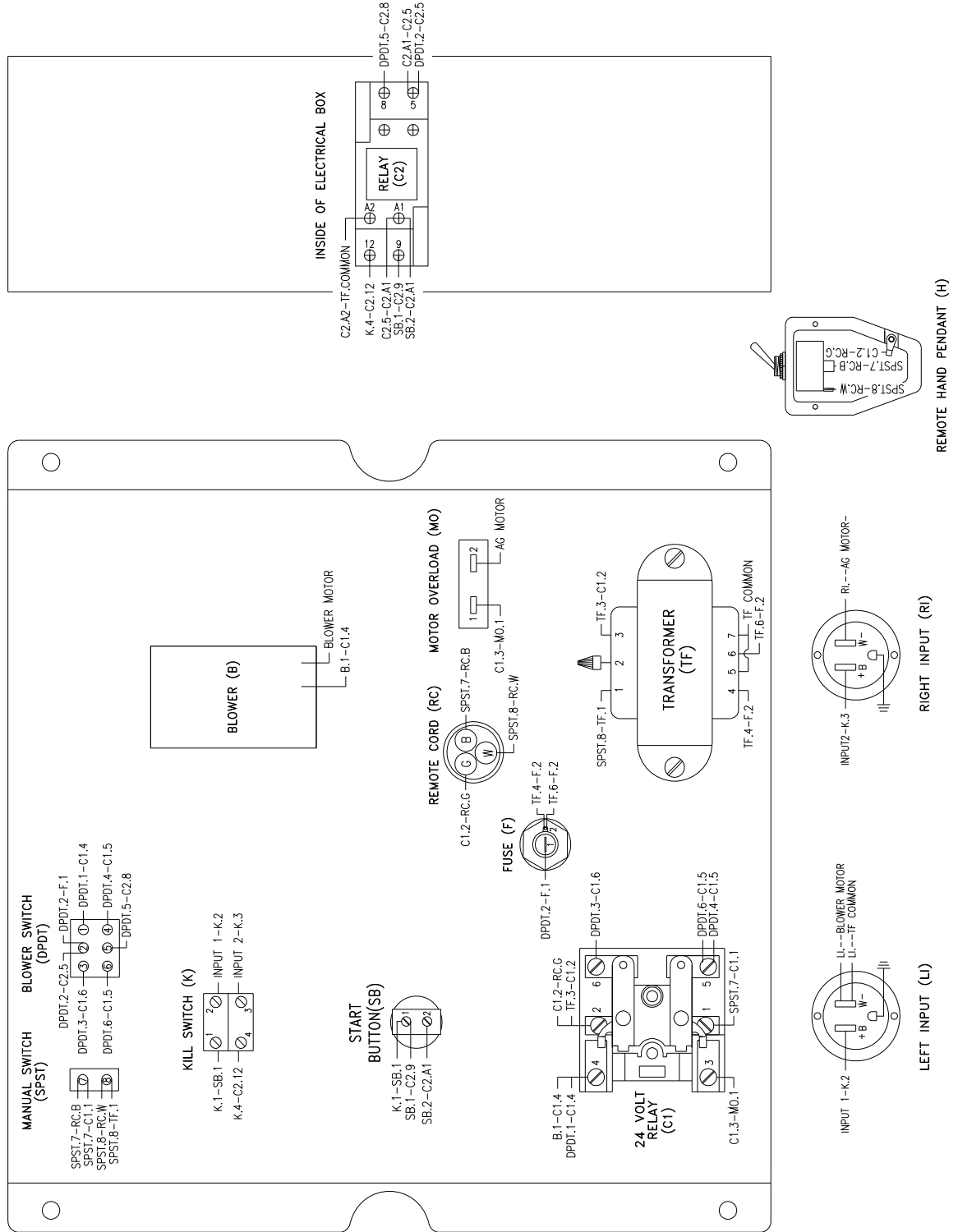

ELECTRICAL DIAGRAM: Periodically, disconnect machine from power source and check all electrical connections and components for broken or loose wires.

MODEL #425
120 V.A.C. 60 Hz Single Input
Standard Electrical W/Blower Control

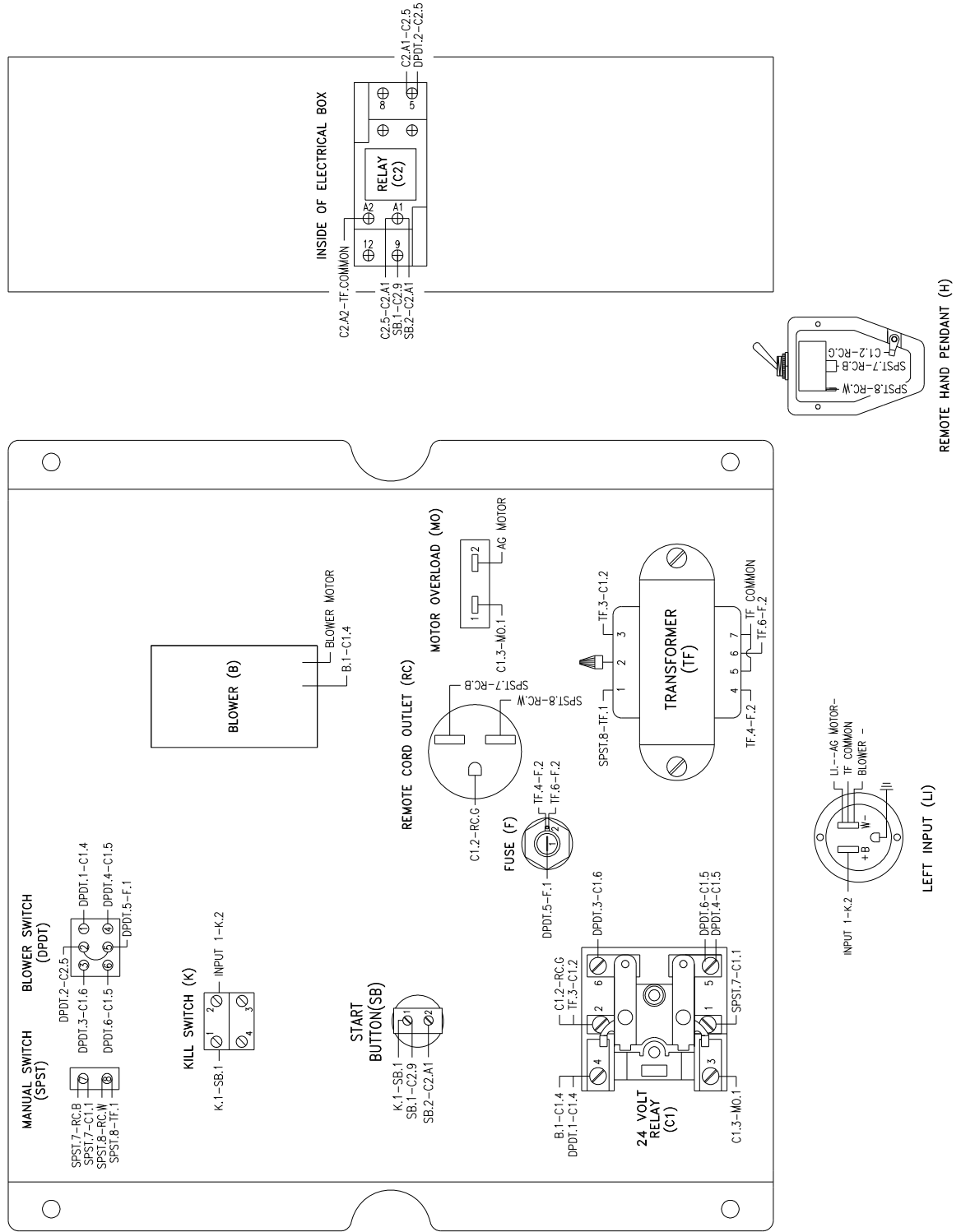

ELECTRICAL DIAGRAM:

Periodically, disconnect machine from power source and check all electrical connections and components for broken or loose wires.

MODEL #425
120 V.A.C. 60 Hz Double Input
Standard Electrical W/Blower Control

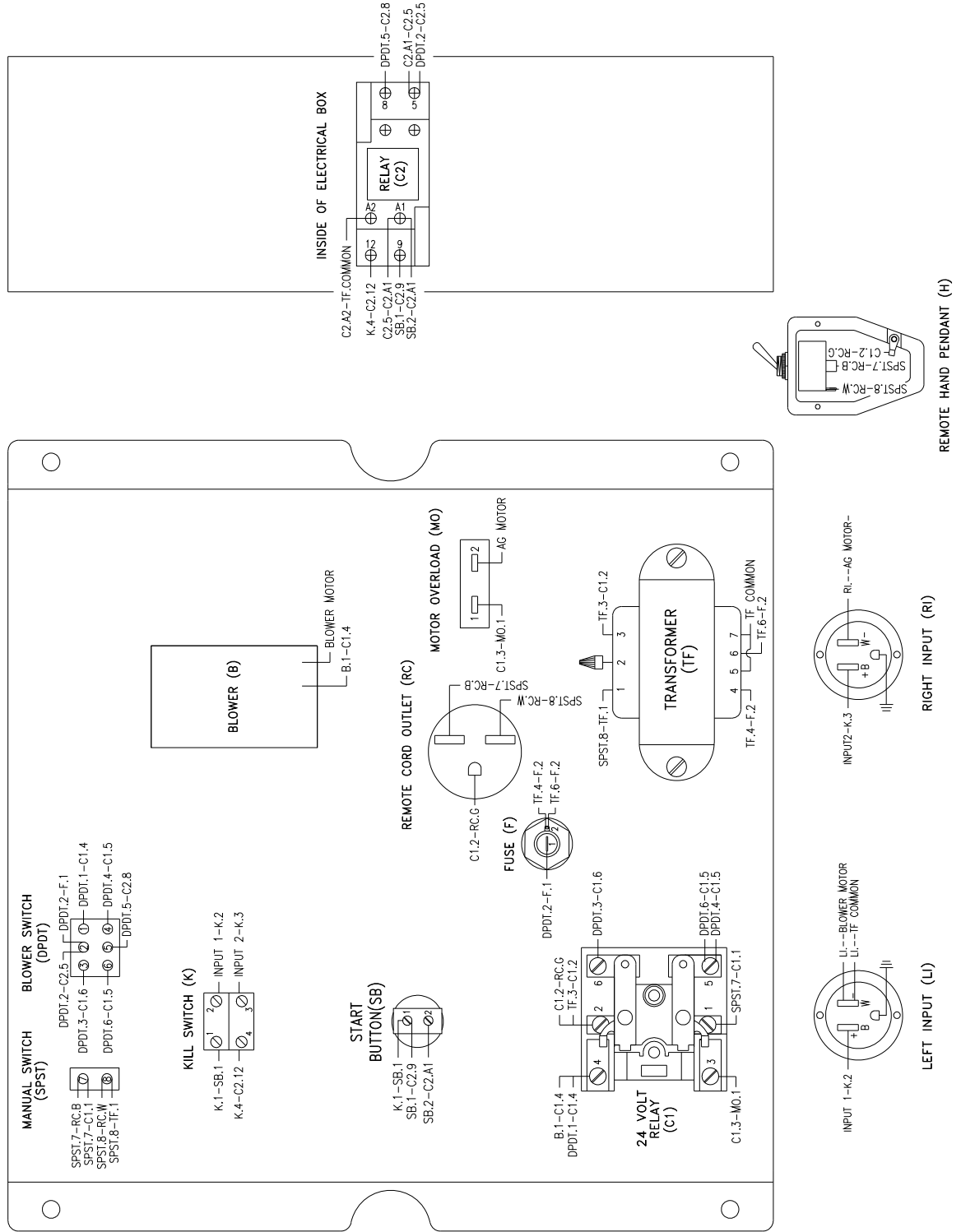

LADDER DIAGRAM

**SINGLE BLOWER CONTROL PANEL
120 VOLT 60 HZ SINGLE INPUT
W/O BLOWER CONTROL**

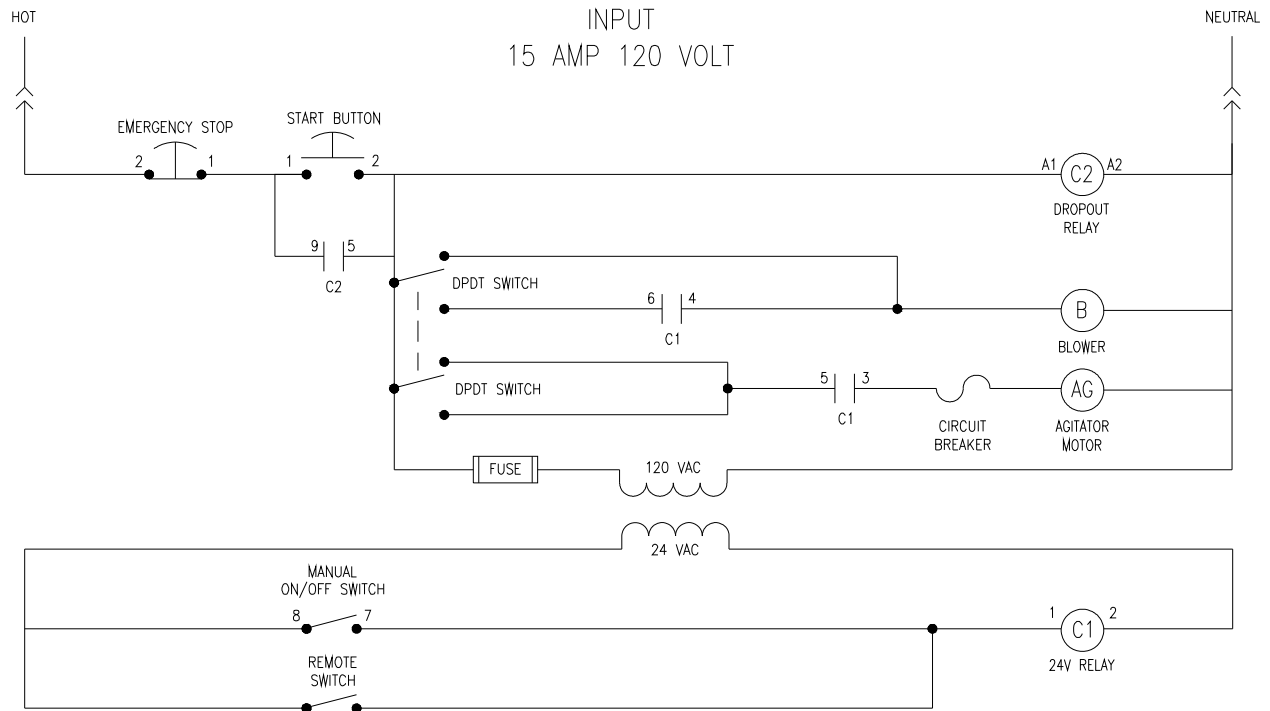

LADDER DIAGRAM

**SINGLE BLOWER CONTROL PANEL
120 VOLT 60 HZ DOUBLE INPUT
W/O BLOWER CONTROL**

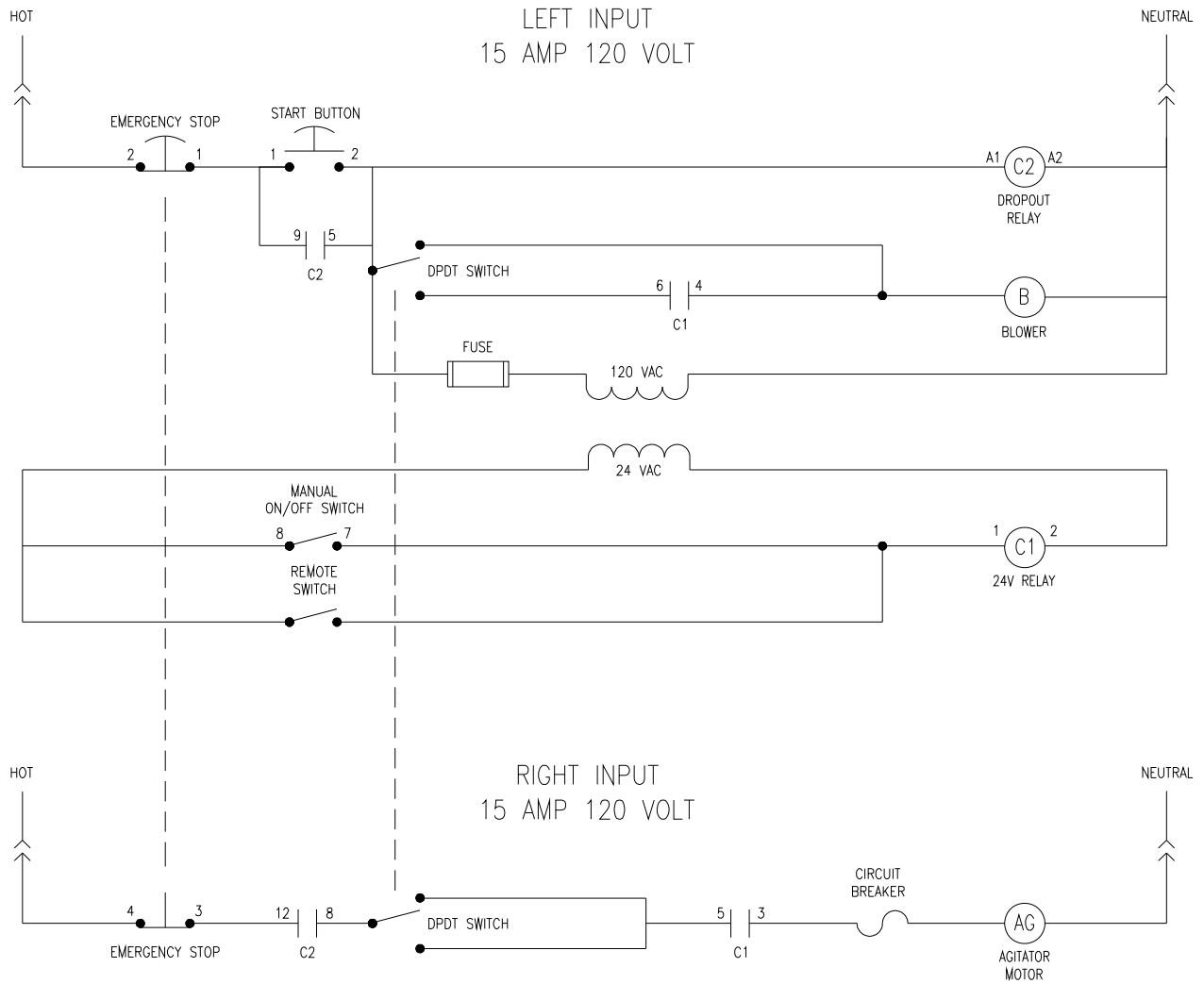

LADDER DIAGRAM

**SINGLE BLOWER CONTROL PANEL
120 VOLT 60 HZ SINGLE INPUT
W/BLOWER CONTROL**

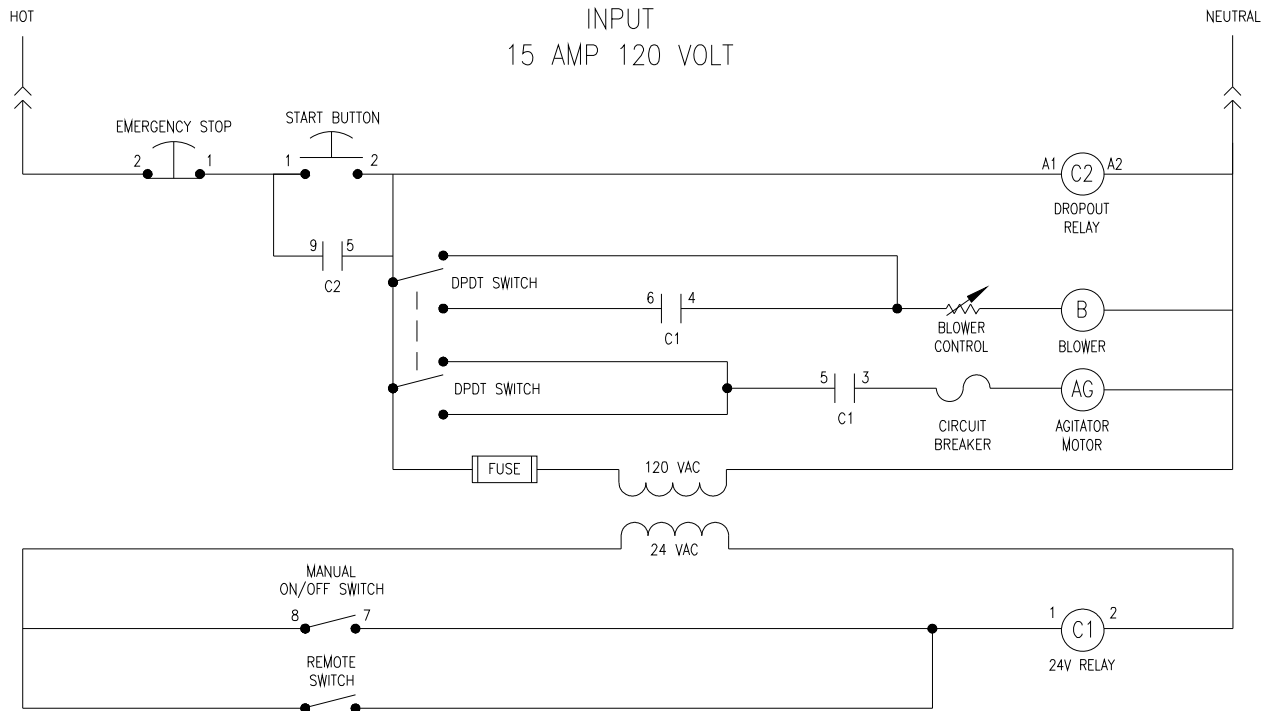

LADDER DIAGRAM

**SINGLE BLOWER CONTROL PANEL
120 VOLT 60 HZ DOUBLE INPUT
W/BLOWER CONTROL**

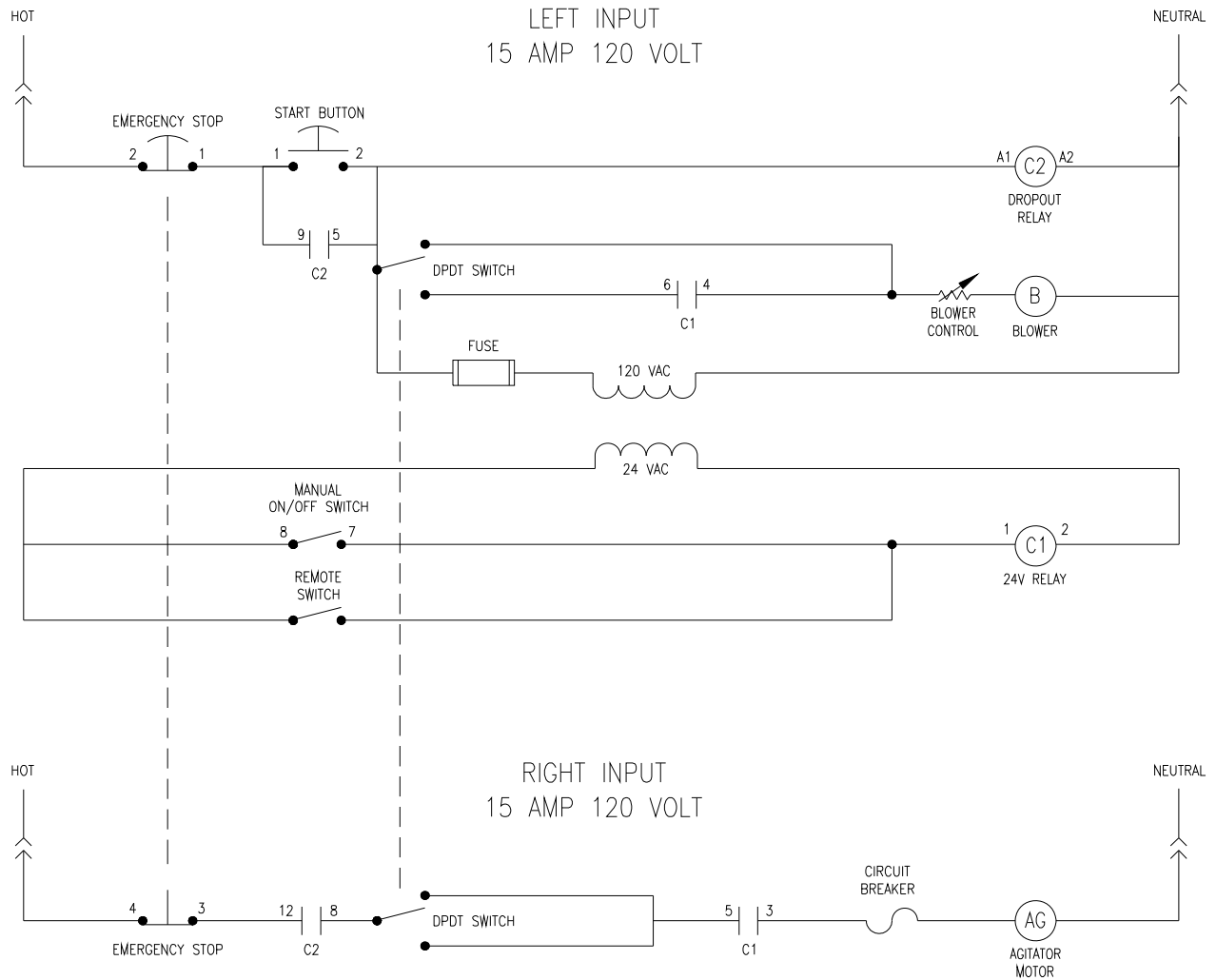

EXPLODED PARTS

#425 Machine

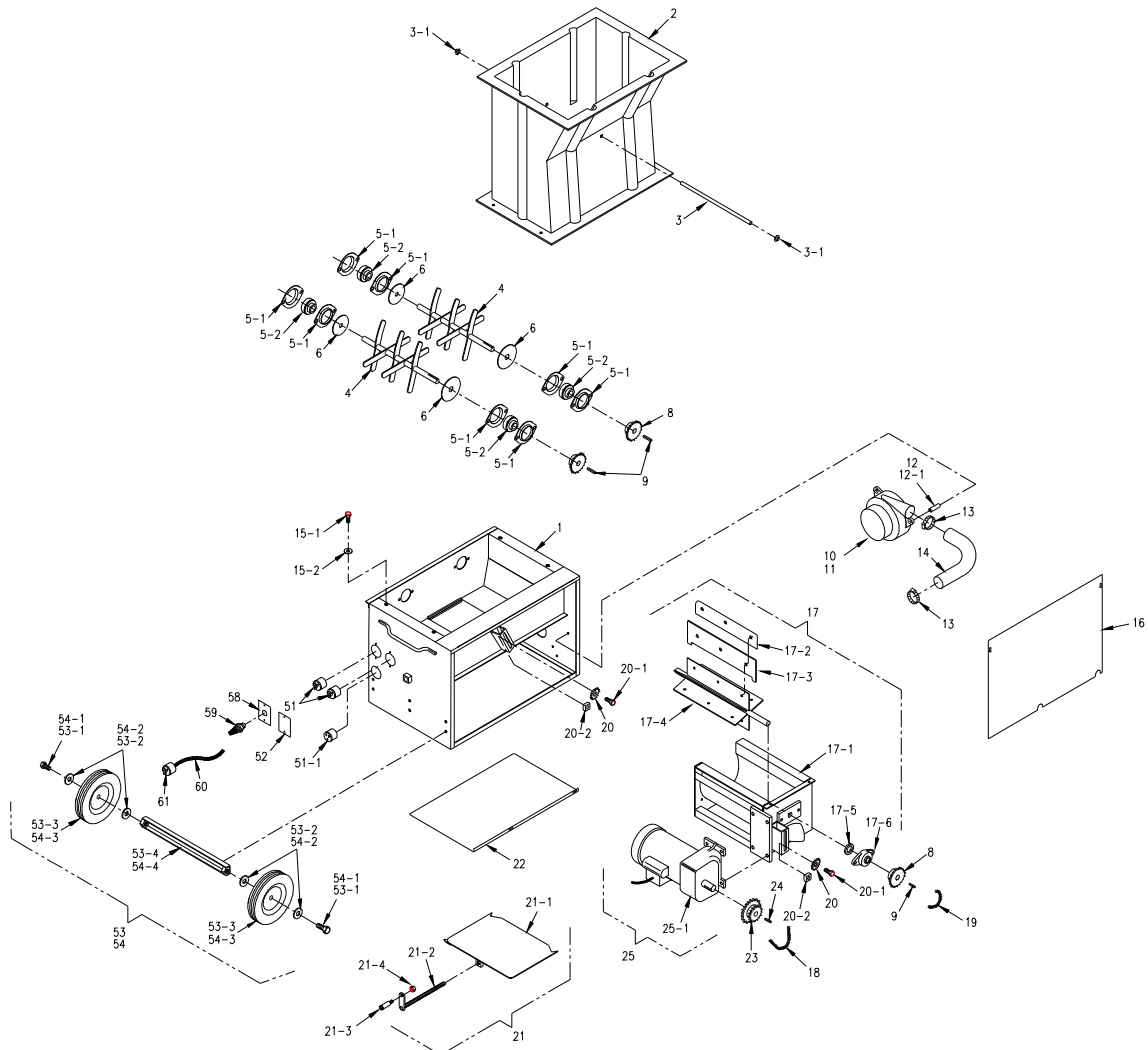
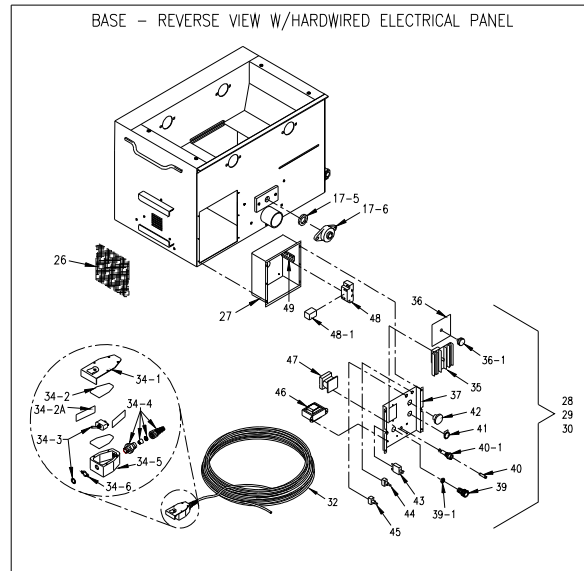
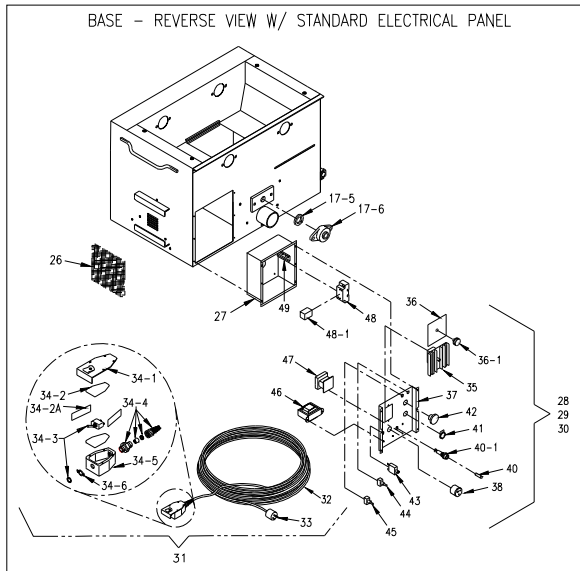

#425 PARTS LIST

Item #	Part #	Description
1	4251-R4	Base (11/09)
2	4252-P	Hopper, Plastic (11/09)
3	4252-05	13 1/2" Hopper bar
3-1	FN009	Pushnut 1/2" (2)
4	42541	Agitator (2)
5-1	1507	Housing, flange, 2-bolt 3/4" stamped (8)
5-2	107-1	Bearing, 3/4" bore (4) insert only
6	1506	Seal, felt 3/4" bore (4)
8	428	#40 Sprocket, 18T x 3/4" (3)
9	448	Key, 3/16" x 3/16" x 7/8" (3)
10	408-A	Blower motor, 8 amp, 2-stage
11	408-E	Blower motor, 12.5 amp, 3-stage
12	409-C	Spacer, blower 2", 8 amp blower (3) (only 1 shown)
12-1	409-D	Spacer, blower, 2 1/2", 12.5 amp blower (3) (only 1 shown)
13	337	Clamp, 2", hose (2)
14	42518	Vent hose, 17" long
15-1	FSB037	SB 5/16-18 x 7/8" HMS (4)
15-2	FW007	Flat Washer, 5/16" (4)
16	4253-R1	Guard, Chain
17	42522-A	Airlock, complete, assembly (8/99)
17-1	42522-1	Airlock Chamber
17-2	4512-2	Plate, top airlock (6)
17-3	4512-3	Seal, airlock (6)
17-4	4512-4	Rotor
17-5	426-7	Seal, felt, 3/4" bolt on bearing (2)
17-6	426-6	Bearing, 2 bolt flange, 3/4" (2)
18	42523	Chain, #40 x 54", N.P.
19	590	Chain, #40 x 25"
---	199	Master link, #40 (2) (not shown)
20	432	Sprocket, Idler, #40 17T x 5/8" (2)
20-1	FSB120	SB 5/8" x 3/4" Shoulder Bolt (2)
20-2	40052	Nut, 1" x 1/2" (1/2-13), plated (2)
21	4255	Slidegate assembly
21-1	4258	Slidegate
21-2	4256-A	Crankrod and bracket
21-3	4507	Handle f/crankrod
21-4	FN015	Lock Nut, 3/8"-16
22	4259-R2	Guard, bottom
23	1024	#40, Sprocket, 15T x 24T x 3/4"
24	1556	Key, 3/16" x 3/16" x 1 1/4"
25	42517-3A	Motor & Cord Assy, 1/2HP, 120V 50/60Hz
25-1	42517-3	Gearmotor, 1/2HP, 50/60Hz
26	42562	Filter, blower 6 1/4" x 6 1/4"
27	4251-32-33	Electrical Box

#425 PARTS LIST

Item #	Part #	Description
Electrical Panel Assemblies		
28	425-A	Electrical panel assy, standard remote, SI, 120V
29	425-C	Electrical panel assy, standard remote, DI, 120V
30	425-A-1	Electrical panel assy, no remote, 120V
Electrical Panel Assemblies (Hardwired)		
28	425-H	Electrical panel assy, hardwired, SI, 120V
29	425-H-M	Electrical panel assy, hardwired, DI, 120V
30	425-H-M1	Electrical panel assy, hardwired, 120V w/blower control
31	395A-B	RC cord assy, 100', style B (Standard Electrical Only)
32	18-3 SJ	Cord, #18-3 (SJ), 100 ft.
33	126-B	Plug, NEMA# 6-15P Style B (Standard Electrical Only)
34-1	1536-1-A	Cover, switch w/belt clip & guard f/hand pendant
34-2	1536-2	Insulator (2)
34-2A	1536-2A	Insulator Strip (2)
34-3	1536-3	Switch, toggle/spst
34-4	1536-4	Cord restraint, 3/8"
34-5	1536-5	Housing, switch
34-6	1536-8	On/Off plate
35	419-A	Blower, control, 120V
36	420-1	Cover, blower control
36-1	420-2	Knob, blower control
37	42564	Electrical Panel
37	42565	Electrical Panel W/O Blower Control
38	132-B	Receptacle, 6-15R (Standard Electrical Only)
39	391N-A-2	Connector, cord, liquid tite, 1/2" white (Hardwired)
39-1	391N-A-3	Locknut, steel, conduit, 1/2" (Hardwired)
40	1533-A	Fuse, 1/2 amp
40-1	1532	Holder, fuse, glass
41	543-M-59	Switch, Pushbutton On
41-1	543-M-60	Start Legend Plate (Not Shown)
42	508-2	Switch, Kill
42-1	8075-1	Contact, Kill Switch (Not Shown)
43	433-D	Manual Reset, 10 amp, 110V
44	1536-3	Switch, SPST
45	109066-9	Switch, DPDT
46	1530-C	Transformer, 1 amp
47	1529-A	Relay, 24 volt, standard
48	ELU09-4	Socket, 8 Pin Relay
48-1	ELU09-5	Relay, DPDT 120V
48-2	ELU09-6	Clip, Hold Down, Relay (Not Shown)
49	ELU07-B	1 3/8" Dinrail, 2 1/2" long

#425 PARTS LIST

Item #	Part #	Description
49-1	151080-49	Clamp, 1 3/8" Dinrail (Not Shown)
50	834	1" Cord clamp (Not Shown)
51	42528	5-15P plug, recessed, input (D.I.=2: S.I.=1)
51-1	1544	5-15R, receptacle, 120V, on/off auxiliary, (optional)
52	42510	Outlet, receptacle cover plate
53	W-6-STD	Wheel package, standard, 6"
53-1	FSB071	Bolt, 5/8-11 x 3 (2)
53-2	FW018	Washer, 9/16, flat washer, (4)
53-3	42520	Wheel, 6" (2)
53-4	4251-09/FN033	Wheel Bracket, 6"
54	W-9-B	Wheel package, 9", Pnuematic
54-1	FSB197	Bolt, 3/4-10 x 3 3/4 (2)
54-2	FW030	Washer, 3/4, flat washer, (4)
54-3	W-9	Wheel, 9" (2)
54-4	4251-09/FN036	Wheel Bracket, 9"
55	RM-CON30222-BK	Wire connector, black, large (Not Shown)
56	RM-CON30211-BK	Wire connector, black, small (Not Shown)
57	DCL425	Decal kit (not shown)
Input Cord Option		
58	42533	Outlet Cover w/hole
59	391N-A-4	Cord Restraint, Liq-Tite
60	12-3 SJ	Cord, 12-3 SJ x 72"
61	127	Plug, 5-15

GLOSSARY

BRIDGING	Tendency of fiber to cling in the hopper forming an air pocket above the airlock. This hinders the normal feeding process of the machine.
CFM	(Cubic feet per minute). A measurement of volume or quantity of air flowing at a certain rate, or air moving capability, of a blower. It is the volume of air moved per minute. Higher volume provides increased coverage and velocity of fiber as it leaves the hose.
COVERAGE	Refers to the amount of fiber coverage, usually measured in square feet, according to the R-value desired. This information is given on the fiber package.
PSI	(Pounds of pressure per square inch). The force exerted on a surface by air/liquid. High-pressure blowers push the fiber through the hose. Higher pressure provides less hose plugging and increased compaction in side wall.
PRODUCTION RATE	Pounds of fiber blown per hour.
RPM	(Revolutions per minute). Speed at which the shaft of a rotating device (i.e. blower fan, agitator) is moving.
R-VALUE	Resistance value. A precise measurement of the insulation's resistance to heat transfer. The higher the resistance value, the slower the heat will transfer through the insulating material.
SETTLED DENSITY	The point at which the fiber will not continue to settle further. Any insulation blown will have a certain amount of progressive settling that occurs after a period of time. Following the fiber manufacturers recommendations for bag rate coverage will provide useful information to accommodate for settling.
SETTLING	Compression or compaction of insulation fibers caused by the weight of the material, vibration of structure, temperature, and humidity cycles.

SERVICE RECORD

DATE	MAINTENANCE PERFORMED	COMPONENTS REQUIRED



50 YEARS OF QUALITY AND SERVICE

Made in the U.S.A.

**KRENDL MACHINE COMPANY • 1201 SPENCERVILLE AVE
DELPHOS, OHIO 45833 • TELEPHONE 419-692-3060 • FAX 419-695-9301
E - MAIL: krendl@krendlmachine.com • WEB SITE: www.krendlmachine.com**
