



Building homes for seniors – Safely, On time, On budget

MSL CONSTRUCTION

Safety Program Manual/Injury & Illness Prevention Program

120 PIKE STREET
DAYTON, NV 89403
775-468-5620 office
775-562-4757 fax

Darryl Fisher
MSL Construction – Managing Member
dfisher@msldevelopment.net
775-737-8906

Mike Deines
MSL Construction – Managing Member - Safety Officer
mdeines@msldevelopment.net
503-551-5969

MSL Construction - VP Construction
doug@msldevelopment.net
509-559-0857

120 Pike Street | Dayton, NV 89403
PH: 775-468-5620 | FX: 775-562-4757
NV LIC # 77693

Revised On: 6-3-2013

Contents

POLICY STATEMENT ON SAFETY	4
DUTIES AND RESPONSIBILITIES	5
COMPLIANCE AND ENFORCEMENT	8
Disciplinary Action	8
SAFETY COMMITTEE	10
COMMUNICATION	11
CODE OF SAFE PRACTICES	12
G. Fueling Vehicles	25
Trailer Safety	25
Using Joint Compounds	27
Applying Finishes: Plaster, Coquina, Popcorn, or other	27
TRENCHING AND SHORING PROCEDURES	49
WELDING AND CUTTING	65
A. GENERAL	65
B. RESPONSIBILITY	65
PROTECTION OF PERSONNEL	68
WELDING OPERATION	68
HEALTH PROTECTION AND VENTILATION	70
WELDING ZONE	71
INDUSTRIAL APPLICATIONS	73
TRAINING	74
COMPRESSED GAS CYLINDERS	75
BLOOD BORNE PATHOGENS	78
Exposure Controls	78
Safe Work Practices	78
Personal Protective Equipment (PPE)	79
Post-Exposure Requirements	79
HEAT ILLNESS AND PREVENTION	81
SCAFFOLDS	83
General Requirements	83
Inspections	84
Mandatory Signs and Tags	84
Modifications	84
HAZARD IDENTIFICATION AND ASSESSMENT	85
Periodic Safety Inspections	86
Documentation of Inspections	86
HAZARD PREVENTION, CORRECTION, AND CONTROL	87
Techniques for Correcting Hazards	87
Documentation of Corrective Action	87
HAZARD COMMUNICATION PROGRAM	88
Introduction	88
Hazardous Material Inventory	88
Material Safety Data Sheets (MSDS)	88
Container Labeling	89
Employee Information and Training	89
Hazardous Non-Routine Tasks	89

Informing Outside Contractors and Vendors.....	89
Employee Rights Under The Hazard Communication Standard	90
FIRST AID AND MEDICAL EMERGENCY PROCEDURES.....	91
First-Aid Kits.....	91
First Aid.....	91
Accident Procedures.....	91
ACCIDENT / EXPOSURE INVESTIGATION.....	93
Responsibility for Accident Investigation.....	93
The Purpose of Accident Investigations	93
What Types of Incidents Do We Investigate?.....	93
Procedures for Investigation of Accidents.....	93
Questions to Ask.....	94
Once the Accident Investigation is Completed.....	95
TRAINING AND INSTRUCTION	96
Documentation of Training.....	97
FIRE PREVENTION AND EMERGENCY ACTION PLAN.....	98
Facility Emergency Evacuation and Fire Prevention.....	98
During an Emergency	98
Fire Prevention in Shops and Warehouses	99
FLEET AND DRIVER SAFETY.....	100
Driver Selection	100
Driver Training.....	100
Company Vehicle Use Policy.....	100
Vehicle Inspection & Preventive Maintenance	101
Accident Investigation	101
Auto Accident Preventability Guide	101
FALL PROTECTION.....	106
Fall Protection is Required	106
Fall Protection Types	106
Standard Guardrails, Safety Cables, or Covers	106
Personal Fall Arrest Systems.....	107
Positioning Device Systems	108
Personal Fall Restraint.....	109
RESPIRATORY PROTECTION	110
General Respiratory Protection Guidelines.....	110
Respirator Selection Requirements.....	111
Medical Evaluation Procedures.....	112
Fit Testing	113
Usage Rules	113
Maintenance, Inspection and Care of Respirators	115
Training.....	116
Program Evaluation	116
Recordkeeping.....	117
Procedures for Cleaning Respirators	117
MANDATORY INFORMATION FOR EMPLOYEES USING RESPIRATORS WHEN NOT REQUIRED	118
ELECTRICAL & LOCK-OUT / TAG-OUT PROGRAM	120
All Equipment and Installations.....	120
Energized Equipment or Systems	120
De-energized Equipment or Systems.....	121
Energizing (or Re-energizing) Equipment or Systems.....	121
Accident Prevention Tags	122

Lock-out / Tag-out	122
Sequence of Lockout Procedure.....	122
Procedure Involving More Than One Person.....	122
Testing Equipment during Lockout.....	123
Restoring Equipment to Service	123
CONFINED SPACE OPERATIONS.....	124
Definitions	124
Typical Confined Spaces	124
Prior to Confined Space Entry	125
Confined Space Entry if Tests Show No Hazard.....	125
Confined Space Entry if Tests Show Hazards are Present or are Likely to Develop.....	125
Confined Spaces Where Dangerous Air Contamination Cannot be Removed by Ventilation.....	126
FORKLIFTS.....	127
General	127
Training Program Implementation	127
Training Program Content	127
Refresher Training and Evaluation	128
Avoidance of Duplicative Training	128
Certification	129
RECORDKEEPING	130
APPENDIXES.....	131
HAZARD ASSESSMENT AND CORRECTION RECORD.....	132
ACCIDENT / EXPOSURE INVESTIGATION REPORT	134
WORKER TRAINING AND INSTRUCTION RECORD.....	135
EMPLOYEE SAFETY CONTACT REPORT	136
NEW EMPLOYEE SAFETY ORIENTATION	137
CODE OF SAFE PRACTICES RECEIPT	138
COMPANY VEHICLE POLICY RECEIPT	139
SAFETY COMMITTEE MEETING MINUTES.....	140
Date of Committee Meeting	140
Minutes prepared by.....	140
SAFETY MEETING MINUTES.....	142
Company	142
Presenter	142
VEHICLE INSPECTION CHECKLIST	143
DRIVER DATE	143
FACILITY INSPECTION CHECKLIST.....	144
GENERAL WORK ENVIRONMENT.....	146

MSL CONSTRUCTION - POLICY STATEMENT ON SAFETY

The management of MSL CONSTRUCTION is very interested in working with you to provide a safe place in which to work. The prevention of accidents and injuries to our employees is the prime objective.

All company personnel are expected to take an active and constant interest in the prevention of accidents. We call upon all employees to use good common sense and in all their actions, take a second to think of the consequences to your fellow employees. We cannot overemphasize that all employees must do their part to minimize accidents.

Please show your support by demonstrating the following:

1. OBSERVING COMPANY SAFETY RULES.
2. KEEPING WORK AREAS FREE OF UNSAFE CONDITIONS.
3. AVOIDING AND ELIMINATING UNSAFE ACTS.
4. PROMPTLY REPORTING UNSAFE ACTS AND CONDITIONS.
5. REPORTING ALL ACCIDENTS IMMEDIATELY.

Accidents cause suffering and pain. We value each of you as individuals and hope you will cooperate with us in this important endeavor.

Any constructive criticism or suggestions toward improving safety on any of our jobs will be given prompt and careful consideration.

Sincerely,

Darryl Fisher
MSL Construction
775-468-5620

DUTIES AND RESPONSIBILITIES

A successful Safety and Injury and Illness Prevention Program can only be achieved and maintained when there is active interest, participation, and accountability at all levels of the organization. To ensure this, the company, delegates the following safety duties to all management personnel. In some cases employees will need to perform safety duties outside their regular responsibilities to prevent accidents.

The Safety Program Administrator must plan, organize, and administer the program by establishing policy, setting goals and objectives, assigning responsibility, motivating subordinates, and monitoring results. Company management will support and maintain an ongoing Safety and Injury and Illness Prevention Program through the following:

1. Providing clear understanding and direction to all management and employees regarding the importance of safety through the development, implementation, monitoring and revision of policy and procedures.
2. Providing financial support for the Safety / Injury and Illness Prevention Program through the provision of adequate funds for the purchase of necessary safety materials, safety equipment, proper personal protective equipment, adequate time for employee safety training, and maintenance of tools and equipment.
3. Overseeing development, implementation, and maintenance of the safety manual, IIPP, and other required safety programs.
4. Maintaining a company commitment to accident prevention by expecting safe conduct on the part of all managers, supervisors, and employees.
5. Holding all levels of management and employees accountable for accident prevention and safety.
6. Reviewing all accident investigations to determine corrective action.

Managers and Supervisors play a key role in the prevention of accidents on the job. They have direct contact with the employees and know the safety requirements for various jobs. Safety responsibilities for these individuals include:

1. Enforce all safety rules in the Code of Safe Practices and ensure safe work procedures.
2. Verifying corrective action has been taken regarding safety hazards and accident investigations.
3. Conducting periodic documented inspections of the work sites to identify and correct unsafe actions and conditions that could cause accidents.
4. Act as a leader in company safety policy and setting a good example by following all safety rules.
5. Becoming familiar with local, state, and federal safety regulations. The Safety Coordinator is available for assistance.
6. Train all new and existing employees in proper safety procedures and the hazards of the job.
7. Instruct all employees, under their supervision, in safe work practices and job safety requirements.
8. Hold weekly safety meetings with employees.
9. Ensure employee proficiency when assigning work requiring specific knowledge, special operations or equipment.

10. Ascertain that all machinery, equipment, and workstations are maintained in safe working condition and operate properly.
11. Correct unsafe acts and conditions that could cause accidents.
12. Communicate with all employees about safety and accident prevention activities.
13. Correct the cause of any accident as soon as possible.
14. Ascertain that proper first aid and firefighting equipment is maintained and used when conditions warrant its use.
15. Maintain good housekeeping conditions at all times.
16. Investigate all injuries and accidents to determine their cause and potential corrective action.
17. Ascertain that all injuries involving our employees that require medical attention are properly treated and promptly reported to the office.

The Safety Program Administrator acts as a safety resource for MSL CONSTRUCTION and is responsible for maintaining program records. They will also be our primary person to deal with outside agencies regarding the safety program and its contents. Additional duties include:

1. Coordination of all loss prevention activities as a representative of management. Acting as a consultant to management in the implementation and administration of the Safety Program.
2. Develop and implement loss prevention policies and procedures designed to insure compliance with the applicable rules and regulations of all federal, state, and local agencies.
3. Review all accident reports to determine cause and preventability.
4. Conduct periodic reviews of the program and job sites to evaluate performance, discuss problems and help solve them.
5. Consult with representatives of our insurance companies in order that their loss control services will support the Safety Program.
6. Review Workers' Compensation Claims. Help supply the insurance carrier with information about injured employees in order to keep loss reserves as low as possible.

Every employee is responsible for working safely, both for self-protection and for protection of fellow workers. Employees must also support all company safety efforts. Specific employee safety responsibilities include:

1. If you are unsure how to do any task safely, ask your supervisor.
2. Read and abide by all requirements of the Safety Manual.
3. Know and follow the Code of Safe Practices and all company safety policies and rules.
4. Wear all required personal protective equipment.
5. Report all accidents and injuries, no matter how minor, to your supervisor immediately.

6. Do not operate any equipment you have not been trained and authorized to use.
7. Report any safety hazards or defective equipment immediately to your supervisor.
8. Do not remove, tamper with or defeat any guard, safety device or interlock.
9. Never use any equipment with inoperative or missing guards, safety devices or interlocks.
10. Never possess, or be under the influence of, alcohol or controlled substances while on the premises.
11. Never engage in horseplay or fighting.
12. Participate in, and actively support, the company safety program.

COMPLIANCE AND ENFORCEMENT

The compliance of all employees with our Safety Manual / IIPP is mandatory and shall be considered a condition of employment.

The following programs will be utilized to ensure employee compliance with the safety program and all safety rules.

- Training programs
- Retraining
- Disciplinary action
- Optional safety incentive programs

Training Programs

The importance of safe work practices and the consequences of failing to abide by safety rules will be covered in the New Employee Safety Orientation and safety meetings. This will help ensure that all employees understand and abide by company safety policies.

Retraining

Employees that are observed performing unsafe acts or not following proper procedures or rules will be retrained by their supervisor. A Safety Contact Report may be completed by the supervisor to document the training. If multiple employees are involved, additional safety meetings will be held.

Safety Incentive Programs

Although strict adherence to safety policies and procedures is required of all employees, the company may choose to periodically provide recognition of safety-conscious employees and job sites without accidents through a safety incentive program.

Disciplinary Action:

The failure of an employee to adhere to safety policies and procedures can have a serious impact on everyone concerned. An unsafe act can threaten not only the health and wellbeing of the employee committing the unsafe act but can also affect the safety of his/her coworkers and customers. Accordingly, any employee who violates any of the company's safety policies will be subject to disciplinary action.

Note: Failure to promptly report any on-the-job accident or injury, on the same day as occurrence, is considered a serious violation of the Company's Code of Safe Practices. Any employee who fails to immediately report a work-related accident or injury, no matter how minor shall be subject to disciplinary action.

Employees will be disciplined for infractions of safety rules and unsafe work practices that are observed, not just those that result in an injury. Often, when an injury occurs, the accident investigation will reveal that the injury was caused because the employee violated an established safety rule and/or safe work practice(s). In any disciplinary action, the supervisor should be cautious that discipline is given to the employee for safety violations, and not simply because the employee was injured on the job or filed a Workers' Compensation claim.

Violations of safety rules and the Code of Safe Practices are to be considered equal to violations of other company policy. Discipline for safety violations will be administered in a manner that is consistent with the company's system of progressive

discipline. If, after training, violations occur, disciplinary action will be taken as follows:

1. Oral warning. Document it, including date and facts on the "Safety Contact Report" form. Add any pertinent witness statements. Restate the policy and correct practice(s).
2. Written warning. Retrain as to correct procedure/practice.
3. Written warning with suspension.
4. Termination

As in all disciplinary actions, each situation is to be carefully evaluated and investigated. The particular step taken in the disciplinary process will depend on the severity of the violation, employee history, and regard to safety. Managers and supervisors should consult with the office if there is any question about whether or not disciplinary action is justified. Employees may be terminated immediately for willful or extremely serious violations. Union or contract employees are entitled to the grievance process specified by their contract.

Note: You must be consistent in the enforcement of all safety rules.

SAFETY COMMITTEE

Purpose

The purpose of the safety committee is to promote workplace safety and health by increasing the communication, education, and involvement of company personnel. The Safety Program Administrator holds permanent membership in the safety committee in order to ensure that responsibility is delegated appropriately.

Membership

The safety committee membership shall be represented by the safety program administrator, supervisory and non-supervisory employees, with non-supervisory employees being the majority. The employees on the committee will be volunteers and will serve on the committee for a two-year term (except for the safety program administrator).

Meetings

There will be one committee meeting every quarter. The dates will be determined by the members' schedules. All committee meetings and training will be conducted during working hours. All committee members will be compensated at their normal rate of pay during the meetings, committee specific training, and any other committee related duties.

Emergency Meetings

The committee may conduct an emergency meeting if the majority of the members feel that such a meeting is necessary. If an emergency meeting is called outside regular working hours, the non-salaried employees will be compensated at their overtime rate.

Recordkeeping

Complete and accurate records of the functions and proceedings of the safety committee will be maintained by the Corporate Office with copies distributed to each worksite.

Meetings will be recorded and minutes will be prepared following each committee meeting. Copies of the minutes will be kept at each worksite. These documents will be made available for inspection upon request by any employee.

Communication

All original written communications between the company and the committee, or true copies thereof, will be maintained at each jobsite and made readily available for inspection by government agencies.

The company shall issue a timely written response to all written questions and recommendations from the safety committee.

COMMUNICATION

This section establishes procedures designed to develop and maintain employee involvement and interest in the Safety Manual. These activities will also ensure effective communication between management and employees on safety related issues that is of prime importance to the company. The following are some of the safety communication methods that may be used:

1. Periodic safety meetings with employees that encourage participation and open, two-way communication.
2. New employee safety orientation and provision of the Code of Safe Practices.
3. Provision and maintenance of employee bulletin boards discussing safety issues, accidents, and general safety suggestions.
4. Written communications from management or the Safety Program Manager, including memos, postings, payroll stuffers, and newsletters.
5. Anonymous safety suggestion program.

Employees will be kept advised of highlights and changes relating to the safety program. Management shall relay changes and improvements regarding the safety program to employees, as appropriate. Employees will be involved in future developments and safety activities, by requesting their opinions and comments, as necessary.

All employee-initiated safety related suggestions shall be properly answered, either verbally or in writing, by the appropriate level of management. Unresolved issues shall be relayed to the program manager or safety committee members.

All employees are encouraged to bring any safety concerns they may have to the attention of management. The company will not discriminate against any employee for raising safety issues or concerns.

The company also has a system of anonymous notification whereby employees who wish to inform the company of workplace hazards without identifying themselves may do so by phoning or sending written notification to the main office.

CODE OF SAFE PRACTICES

GENERAL RULES

All Employees

Ergonomics and Video Display Terminals

1. Take periodic rest breaks from repetitive or prolonged activities by standing up and stretching.
2. Use a chair that is padded, is stable, mobile, swivels, and allows operator movement.
3. Sit straight up in your chair, and when needed use a footrest that has an adjustable height and is large enough to allow operator movement.
4. Adjust your computer screen and keyboard so that they are directly in front of you. Use a table large enough to hold keyboard, the display screen and all necessary documents.
5. Place the keyboard low enough so that the operator is not required to reach up or out to the keys.
6. Keep wrists and hands in a straight position while key stroking by keeping forearms parallel to the floor and elbows at your sides.

Housekeeping

1. Do not place materials such as boxes or trash in walkways and passageways.
2. Sweep up shavings from around equipment such as drill presses, lathes, or planers by using a broom and a dustpan.
3. Mop up water around drinking fountains and drink dispensing machines immediately.
4. Do not store or leave items on stairways.
5. Do not block or obstruct stairwells, exits, or accesses to safety and emergency equipment such as fire extinguishers or fire alarms.
6. Do not block the walking surfaces of elevated working platforms with tools or materials that are not being used.
7. Straighten or remove rugs and mats that do not lie flat on the floor.
8. Remove protruding nails or bend them down into the lumber by using a claw hammer.
9. Return tools to their storage places after using them.
10. Use caution signs or cones to barricade slippery areas such as freshly mopped floors.

Ladders and Step Ladders

1. Read and follow the manufacturer's instruction label affixed to the ladder.
2. Do not use ladders that have loose rungs, cracked, or split side rails, missing rubber footpads, or are otherwise visibly damaged.
3. Keep ladder rungs clean and free of grease. Remove buildup of material such as dirt or mud.
4. Do not place ladders in a passageway or doorway without posting warning signs or cones that detour pedestrian traffic away from the ladder. Lock the doorway that you are blocking with the ladder and post signs that will detour traffic away from your work.
5. Do not place a ladder at a blind corner or doorway without diverting foot traffic by blocking or roping off the area.
6. Allow only one person on the ladder at a time.
7. Face the ladder when climbing up or down it.
8. Maintain a three-point contact by keeping both hands and one foot or both feet and one hand on the ladder at all times when climbing up or down the ladder.
9. When performing work from a ladder, face the ladder and do not lean backward or sideways from the ladder.
10. Do not stand on tables, chairs, boxes or other improvised climbing devices to reach high places. Use the ladder or stepstool.
11. Do not stand on the top two rungs of any ladder.
12. Do not stand on a ladder that wobbles, or that leans to the left or right of center.
13. When using a straight or extension ladder, extend the top of the ladder at least 3 feet above the edge of the landing.
14. Secure the ladder in place by having another employee hold it if it cannot be tied to the structure.
15. Do not move a rolling ladder while someone is on it.
16. Do not place ladders on barrels, boxes, loose bricks, pails, concrete blocks, or other unstable bases.
17. Do not carry items in your hands while climbing up or down a ladder.

18. Do not try to "walk" a ladder by rocking it. Climb down the ladder, and then move it.
19. Do not use a ladder as a horizontal platform.

Lifting Procedures

1. Plan the move before lifting; ensure that you have an unobstructed pathway.
2. Test the weight of the load before lifting by pushing the load along its resting surface.
3. If the load is too heavy or bulky, use lifting and carrying aids such as hand trucks, dollies, pallet jacks and carts, or get assistance from a co-worker.
4. If assistance is required to perform a lift, coordinate and communicate your movements with those of your co-worker.
5. Position your feet 6 to 12 inches apart with one foot slightly in front of the other.
6. Face the load.
7. Bend at the knees, not at the back.
8. Keep your back straight.
9. Get a firm grip on the object using your hands and fingers. Use handles when they are present.
10. Hold the object as close to your body as possible.
11. While keeping the weight of the load in your legs, stand to an erect position.
12. Perform lifting movements smoothly and gradually; do not jerk the load.
13. If you must change direction while lifting or carrying the load, pivot your feet and turn your entire body. Do not twist at the waist.
14. Set down objects in the same manner as you picked them up, except in reverse.
15. Do not lift an object from the floor to a level above your waist in one motion. Set the load down on a table or bench and then adjust your grip before lifting it higher.
16. Never lift anything if your hands are greasy or wet.
17. Wear protective gloves when lifting objects that have sharp corners or jagged edges.

OFFICE SAFETY

General Rules

1. Do not stand on furniture to reach high places.
2. Do not kick objects out of your pathway; pick them up or push them out of the way.
3. Do not jump from ladders or step stools.
4. Do not block your view by carrying large or bulky items; use the dolly or hand truck or get assistance from a fellow employee.
5. Do not throw matches, cigarettes or other smoking materials into trash baskets.
6. Do not tilt the chair you are sitting in. Keep all chair legs on the floor.
7. Use the ladder or step stool to retrieve or store items that are located above your head.

Doors

1. Keep doors in hallways fully open or fully closed.
2. Use the handle when closing doors.

Files

1. Open only one file cabinet drawer at a time. Close the filing cabinet drawer you are working in before opening another filing drawer in the same cabinet.
2. Put heavy files in the bottom drawers of file cabinets.
3. Use the handle when closing drawers and files.

Sharp Objects

1. Store sharp objects, such as pens, pencils, letter openers or scissors in drawers or with the tips pointing down in a container.
2. Carry pencils, scissors, and other sharp objects with the tips pointing down.

Paper Cutter/Shredder

1. Position hands and fingers on the handle of the paper cutter before pressing down on the blade.
2. Keep the paper cutter handle in the closed or locked position when it is not being used.
3. Do not use paper-cutting devices if the finger guard is missing.
4. Do not place your fingers in or near the feed of a paper shredder.

Staplers

1. Point the ejector slot away from yourself and bystanders when refilling staplers.
2. Keep fingers away from the ejector slot when loading or testing stapling devices.
Use a staple remover, not your fingers, for removing staples.

Electrical

1. Do not use frayed, cut, or cracked electrical cords.
2. Do not plug multiple electrical cords into a single outlet.
3. Do not use extension or power cords that have the ground prong removed or broken off.
4. Use a cord cover or tape the cord down when running electrical cords across aisles, between desks or across entrances or exits.
5. Turn the power switch to "Off" and unplug office machines before adjusting, lubricating or cleaning them.

Fans

1. Do not use fans that have excessive vibration or missing guards.
2. Do not place floor type fans in walkways, aisles, or doorways.

Stairs

1. Use the handrails when ascending or descending stairs or ramps.
2. Do not run on stairs or take more than one-step at a time.

Phone Use

1. Sit up straight in your chair.
2. Keep your feet on floor.
3. If the chair height is too high, use a book or other object as a footrest.
4. If you use a traditional handset, do not hold the receiver by bending your neck to trap the receiver between your head and shoulder. Hold the receiver with your hand.
5. Use your headset for extended phone use.
6. For additional lower back support, place a pillow or bundled clothing in the chair at the small of your back.

Carts

1. Do not exceed the rated load capacity noted on the manufacturer's label on the cart.
2. Ask a spotter to help guide carts around corners and through narrow aisles.
3. Do not stand on a cart or float or use it as a work platform.

Hand Truck Operations

1. When loading hand trucks, keep your feet clear of the wheels.
2. Do not exceed the manufacturer's load rated capacity. Read the capacity plate on the hand truck if you are unsure.
3. Place the load so that it will not slip, shift, or fall. Use the straps, if they are provided, to secure the load.
4. For extremely bulky or pressurized items such as gas cylinders, strap or chain the items to the hand truck.
5. Tip the load slightly forward so that the tongue of the hand truck goes under the load.
6. Push the tongue of the hand truck all the way under the load that is to be moved.
7. Keep the center of gravity of the load as low as possible by placing heavier objects below the lighter objects.
8. Push the load so that the weight will be carried by the axle and not the handles.
9. If your view is obstructed, ask a spotter to assist in guiding the load.

10. Do not walk backward with the hand truck, unless going up stairs or ramps.
11. When going down an incline, keep the hand truck in front of you so that it can be controlled at all times.
12. Move hand trucks at a walking pace.
13. Store hand trucks with the tongue under a pallet, shelf, or table.

Hazardous Materials

1. Follow the instructions on the label and in the corresponding Material Safety Data Sheet (MSDS) for each chemical product you will be using in your workplace.
2. Use personal protective clothing or equipment such as goggles, face shield, neoprene gloves, rubber boots, shoe covers, and rubber aprons, when using chemicals labeled "Flammable", "Corrosive", and "Caustic" or "Poisonous".
3. Do not use protective clothing or equipment that has split seams, pinholes, cuts, tears, or other visible signs of damage.
4. Do not use chemicals from unlabeled containers or unmarked cylinders.
5. Do not drag containers labeled "Flammable."
6. Do not store chemical containers labeled "Oxidizer" with containers labeled "Corrosive" or "Caustic".

Storeroom/Stockroom:

1. Use long handled snips when cutting strapping bands away from a shipping container.
2. Wear your safety glasses when cutting strapping bands, uncrating materials, and driving nails.
3. Stand to the side of the strapping band when cutting it. Use extreme care when removing bands from pipe on round stock loads. Chock or block loads before removing band to prevent a load shift.
4. Do not use pallets or skids that are cracked or split or have other visible damage.
5. Stack heavy or bulky storage containers on middle and lower shelves of the storage rack.
6. Do not run on stairs or take more than one-step of a staircase at a time.
7. Do not jump from elevated places such as truck beds, platforms, or ladders.
8. Do not lift slippery or wet objects; use a hand truck.
9. Follow the safe handling instructions listed on the label of the container or listed on the corresponding Material Safety Data Sheet when handling each chemical stored in the stockroom.
10. Do not handle or load any containers of chemicals if their containers are cracked or leaking.

CARPENTRY

ELECTRICAL POWERED TOOLS

1. Do not use power equipment or tools on which you have not been trained.
2. Keep power cords away from the path of drills, saws, vacuum cleaners, floor polishers, mowers, slicers, knives, grinders, irons, and presses.
3. Do not carry plugged-in equipment or tools with your finger on the switch.
4. Do not carry equipment or tools by the cord.
5. Disconnect the tool from the outlet by pulling on the plug, not the cord.
6. Turn the tool off before plugging or unplugging it.
7. Do not leave tools that are "On" unattended.
8. Do not handle or operate electrical tools when your hands are wet or when you are standing on wet floors.
9. Do not operate spark inducing tools such as grinders, drills, or saws near containers labeled "Flammable" or in an explosive atmosphere such as a paint spray booth.
10. Turn off electrical tools and disconnect the power source from the outlet before attempting repairs or service work. Tag the tool "Out of Service."
11. Do not connect multiple electrical tools into a single outlet.
12. Do not run extension cords through doorways, through holes in ceilings, walls, or floors.
13. Do not drive over, drag, step on or place objects on a cord.
14. Do not operate a power hand tool or portable appliance with a two-pronged adapter or a two-conductor extension cord.
15. Do not use a power hand tool while wearing wet cotton gloves or wet leather gloves.

16. Never operate electrical equipment barefooted. Wear rubber-soled or insulated work boots.
17. Do not operate a power hand tool or portable appliance while holding a part of the metal casing or holding the extension cord in your hand. Hold all portable power tools by the plastic handgrips or other nonconductive areas designed for gripping purposes.
18. Do not operate a power hand tool or portable appliance that has a frayed, worn, cut, improperly spliced, or damaged power cord.
19. Do not operate a power hand tool or portable appliance if the ground pin from the three-pronged power plug is missing or has been removed.

GARAGE DOORS

1. Do not use undersized rods or other improvised tools to wind garage door springs.
2. Engage garage door lock in the "locked" position before winding the springs.
3. Do not attempt to adjust winding cones or bars when the garage door is in the full open position.

HAND TOOLS

1. Use tied-off containers to keep tools from falling off scaffolds and other elevated work platforms.
2. Keep the blades of all cutting tools sharp.
3. Carry all sharp tools in sheaths or holsters.
4. Tag worn, damaged, or defective tools "Out of Service" and do not use them.
5. Do not use a tool if its handle has splinters, burrs, cracks, splits or if the head of the tool is loose.
6. Do not use impact tools such as hammers, chisels, punches, or steel stakes that have mushroomed heads.
7. When handing a tool to another person, direct sharp points and cutting edges away from yourself and the other person.
8. Do not chop at heights above your head when working with a hand axe.
9. Do not carry sharp or pointed hand tools such as screwdrivers, scribes, aviation snips, scrapers, chisels or files in your pocket unless the tool or pocket is sheathed.
10. Do not perform "make-shift" repairs to tools.
11. Do not use "cheaters" on load binders or "boomers."
12. Do not carry tools in your hand when climbing. Carry tools in tool belts or hoist the tools to the work area with a hand line.
13. Do not throw tools from one location to another, from one employee to another, from scaffolds or other elevated platforms.

Chisels

1. Keep the cutting edge of the chisel sharp.
2. Do not use chisels with damaged striking ferrules.
3. Hold a chisel with a tool holder if possible.
4. Clamp a small work piece in a vise and chip towards the stationary jaw when working with a chisel.

Clamps

1. Do not use the C-clamp for hoisting materials.
2. Do not use the C-clamp as a permanent fastening device.

Files/Rasps

1. Do not use a file as a pry bar, hammer, screwdriver, or chisel.
2. When using a file or a rasp, grasp the handle in one hand and the toe of the file in the other.
3. Do not hammer on a file.

Hammers

1. Use a claw hammer for pulling nails and driving nails.
2. Do not strike nails or other objects with the cheek of the hammer.
3. Do not strike a hardened steel surface, such as a cold chisel, with a claw hammer.

4. Do not strike one hammer against another hammer.
5. Do not use a hammer if your hands are oily, greasy, or wet.
6. Do not use a hammer as a wedge, a pry bar or for pulling large spikes.
7. Use only a sledge-type hammer on a striking face wrench.

Knives/Sharp instruments

1. When handling knife blades and other cutting tools, direct sharp points and edges away from you.
2. Store knives in knife blocks or in sheaths after use.
3. Do not use knives with dull blades.
4. Do not use honing steels that do not have disc guards.
5. Do not attempt to catch a falling knife.
6. Use knives for the operation for which they are named.
7. Do not use knives with broken or loose handles.
8. Do not use knives as screwdrivers, pry bars, can openers or ice picks.
9. Do not pick up knives by their blades.
10. Carry knives with their tips pointed towards the floor.

Pliers

1. Do not attempt to force pliers by using a hammer on them.
2. Do not slip a pipe over the handles of pliers to increase leverage.
3. Use pliers with insulated handles for electrical work.
4. Do not use pliers that are cracked, broken, or sprung.
5. When using diagonal cutting pliers, shield the loose pieces of cut material from flying into the air by using a cloth or your gloved hand.

Saws

1. Do not use an adjustable blade saw such as a hacksaw, coping saw, keyhole saw, or bow saw, if the blade is not taut.
2. Do not use a saw that has dull saw blades.
3. Keep hands and fingers away from the saw blade while using the saw.
4. Do not carry a saw by the blade.
5. When using a handsaw, hold the work piece firmly against the worktable.
6. Do not use woodworking equipment such as circular saws, radial saws, or jointers if they do not have guards on the saw blade.
7. Keep control of saws by decreasing downward pressure at the end of the stroke.
8. When operating scroll saws, stop the machine before removing scrap pieces from the table.
9. Clamp work when using a hole saw.

Screwdrivers

1. Always match the size and type of screwdriver blade to fit the head of the screw.
2. Do not hold the work piece against your body while using a screwdriver.
3. Do not put your fingers near the blade of the screwdriver when tightening a screw.
4. Use an awl, drill or a nail to make a starting hole for screws.
5. Do not force a screwdriver by using a hammer or pliers on it.
6. Do not use a screwdriver as a punch, chisel, pry bar or nail puller.
7. Use a screwdriver that has an insulated handle for electrical work.
8. Do not use a screwdriver if your hands are wet, oily, or greasy.
9. Do not use a screwdriver to test the charge of a battery.
10. When using a spiral ratchet screwdriver, push down firmly and slowly.

Snips

1. Wear safety glasses or safety goggles when using snips to cut materials.

2. Wear work gloves when cutting materials with snips.
3. Do not use straight cut snips to cut curves.
4. Keep the blade aligned by tightening the nut and bolt on the snips.
5. Do not use snips as a hammer, screwdriver, or pry bar.
6. Use the locking clip on the snips after use.

Vises

1. When clamping a long work piece in a vise, support the far end of the work piece by using an adjustable pipe stand, sawhorse, or box.
2. Position the work piece in the vise so that the entire face of the jaw supports the work piece.
3. Do not use a vise that has worn or broken jaw inserts, or has cracks or fractures in the body of the vise.
4. Do not slip a pipe over the handle of a vise to gain extra leverage.

HAZARDOUS MATERIALS

1. Follow the instructions on the label and in the corresponding Material Safety Data Sheet (MSDS) for each chemical product used in your workplace.
2. Do not use chemicals from unlabeled containers and unmarked cylinders.

HOUSEKEEPING

1. Do not place material such as boxes or trash in walkways and passageways.
2. Sweep up shavings from around equipment such as drill presses, lathes, or planers by using a broom and a dustpan.
3. Do not block or obstruct stairwells, exits or accesses to safety and emergency equipment such as fire extinguishers or fire alarms.
4. Keep walking surfaces of elevated working platforms, such as scaffolds, clear of tools and materials that are not being used.
5. Remove protruding nails or bend them down into the lumber by using a claw hammer.
6. Return tools to their storage places after use.
7. Do not use gasoline for cleaning purposes.

LADDERS AND STEP LADDERS

1. Read and follow the manufacturer's instructions label affixed to the ladder if you are unsure how to use the ladder.
2. Do not use ladders that have loose rungs, cracked or split side rails, missing rubber footpads, or are otherwise visibly damaged.
3. Keep ladder rungs clean and free of grease. Remove material buildup such as dirt or mud.
4. Do not use a metal ladder on rooftops or within 50 feet of electrical power lines.
5. Allow only one person on the ladder at a time.
6. Face the ladder when climbing up or down.
7. Maintain a three-point contact by keeping both hands and one foot or both feet and one hand on the ladder at all times when climbing up or down.
8. When performing work from a ladder, face the ladder and do not lean backward or sideways from the ladder.
9. Do not stand on the top two rungs of any ladder.
10. Do not stand on a ladder that wobbles, or that leans to the left or right.
11. When using a straight ladder, extend the top of the ladder at least 3 feet above the edge of the landing.
12. Do not move a rolling ladder while someone is on it.
13. Do not place ladders on barrels, boxes, loose bricks, pails, concrete blocks, or other unstable bases.
14. Do not carry items in your hands while climbing up or down a ladder.
15. Do not try to "walk" a ladder by rocking it. Climb down the ladder, and then move it.
16. Do not use a ladder as a horizontal platform.

LIFTING PROCEDURES

1. Plan the move before lifting; remove obstructions from your chosen pathway.

2. Test the weight of the load before lifting by pushing the load along its resting surface.
3. If the load is too heavy or bulky, use lifting and carrying aids such as hand trucks, dollies, pallet jacks and carts, or get assistance from a co-worker.
4. If assistance is required to perform a lift, coordinate and communicate your movements with those of your co-worker.
5. Position your feet 6 to 12 inches apart with one foot slightly in front of the other.
6. Face the load.
7. Bend at the knees, not at the back.
8. Keep your back straight.
9. Get a firm grip on the object with your hands and fingers. Use handles when present.
10. Never lift anything if your hands are greasy or wet.
11. Wear protective gloves when lifting objects with sharp corners or jagged edges.
12. Hold objects as close to your body as possible.
13. Perform lifting movements smoothly and gradually; do not jerk the load.
14. If you must change direction while lifting or carrying the load, pivot your feet and turn your entire body. Do not twist at the waist.
15. Set down objects in the same manner as you picked them up, except in reverse.
16. Do not lift an object from the floor to a level above your waist in one motion. Set the load down on a table or bench and then adjust your grip before lifting it higher.
17. Slide materials to the end of the tailgate before attempting to lift them off of a pick-up truck. Do not lift over the walls or tailgate of the truck bed.

PERSONAL PROTECTIVE EQUIPMENT

1. Do not paint or drill holes in hard hats.
2. Do not wear hard hats that are dented or cracked.
3. Wear safety glasses, goggles, or face shield when using chippers, grinders, lathes, or sanders.
4. Wear earplugs or earmuffs in areas posted "Hearing Protection Required."

PNEUMATIC TOOLS

1. Do not point a compressed air hose at bystanders or use it to clean your clothing.
2. Do not use tools that have handles with burrs or cracks.
3. Do not use compressors if their belt guards are missing. Replace belt guards before use.
4. Turn the tool "off" and let it come to a complete stop before leaving it unattended.
5. Disconnect the tool from the airline before making any adjustments or repairs to the tool.
6. Engage positive locks on hoses and attachments before use.
7. Shut off pressure valve and disconnect airline when not in use.
8. Tag damaged or defective pneumatic tools "Out of Service" to prevent usage of the tool by other employees.

POWDER ACTUATED TOOLS

1. Only employer-authorized personnel, with a valid certification card may operate powder-actuated tools.
2. Wear safety glasses, goggles, or face shields when operating powder actuated tools.
3. Wear earplugs or earmuffs when making fastenings.
4. Do not permit bystanders in the area when using a powder-actuated tool.
5. Do not load tool until ready to make a fastening.
6. Keep tool pointed in a safe direction (away from personnel).
7. Post a sign alerting co-workers that a powder actuated tool is being used.
8. After use, lock powder actuated tools and powder loads in a container and store in a safe place such as a locker or the trunk of a car.

SCAFFOLDING

1. Follow the manufacturer's instructions when erecting the scaffold.
2. Do not work on scaffolds outside during stormy or windy weather.

3. Do not climb on scaffolds that wobble or lean to one side.
4. Initially inspect scaffold prior to mounting. Do not use a scaffold if any pulley, block, hook, or fitting is visibly worn, cracked, rusted, or otherwise damaged. Do not use a scaffold if any rope is frayed, torn, or visibly damaged.
5. Do not use any scaffold tagged "Out of Service."
6. Do not use unstable objects such as barrels, boxes, loose brick or concrete blocks to support scaffolds or planks.
7. Do not use a scaffold unless guardrails and all flooring are in place.
8. Level the scaffold after each move. Do not extend adjusting leg screws more than 12 inches.
9. Do not walk or work beneath a scaffold unless a wire mesh has been installed between the mid-rail and the toe board or planking.
10. Use safety belts and lanyards when working from scaffolds that are higher than 10 feet and that do not have top and mid-guard rails.
11. Do not climb the cross braces for access to the scaffold. Use a ladder.
12. Do not jump from, to, or between scaffolding.
13. Do not slide down cables, ropes or guys used for bracing.
14. Keep both feet on the decking. Do not sit or climb on the guardrails.
15. Do not lean out from the scaffold. Do not rock the scaffold.
16. Keep the scaffold free of scraps, loose tools, tangled lines and other obstructions.
17. Do not throw anything "overboard" unless a spotter is available. Use debris chutes or lower things by hoist or by hand.
18. Do not move a mobile scaffold with anyone on the scaffold.
19. Lock and chock wheels on rolling scaffolds before using.

STAIRWAYS, FLOORS AND OPENINGS

1. Do not work on open sided floors, elevated walkways or elevated platforms if there are no guardrails in place.
2. Stand clear of floor openings if guardrails or covers are removed or displaced.

HEAVY EQUIPMENT OPERATORS

Site Safety

1. Do not start work until barricades, barrier logs, fill or other protection have been installed to isolate the work area from local traffic.
2. Do not work outdoors during lightning storms.
3. Drink plenty of clear liquids during your breaks.
4. Take breaks in shaded areas.

Heavy Equipment Safety

General

1. No passengers are permitted on heavy equipment.
2. Keep windows and windshield clean.
3. Do not use heavy equipment if its horn or backup alarm does not sound.
4. Turn off the engine before leaving heavy equipment unattended.
5. Do not jump off of or onto any heavy equipment.
6. Keep heavy equipment in gear when going down grade. Do not use neutral.
7. Display the "Slow Moving Vehicle" sign when operating heavy equipment on roads.
8. Do not operate backhoes, power shovels and other heavy equipment within two (2) feet from the edge of an excavation.

Backhoe/Power Shovel Operations

1. Do not use a bucket or other attachments for a staging or temporary platform for workers.
2. Do not operate backhoe over or across underground utilities that are marked by paint, flagged, or staked.
3. Set swing brake of the bucket arm when moving the vehicle to and from the digging site.
4. Stay in the compartment during operation of the backhoe or power shovel. Do not reach in or attempt to operate controls from outside the backhoe or power shovel.

Forklifts Pre-Use Inspection

Do not use forklift if any of the following conditions exist:

1. The mast has broken or cracked weld-points.
2. The roller tracks are not greased or the chains are not free to travel.
3. Forks are unequally spaced or cracks exist along the blade or at the heels.
4. Hydraulic fluid levels are low.
5. Hydraulic line and fitting have excessive wear or are crimped.
6. Fluid is leaking from the lift or the tilt cylinders.
7. The hardware on the cylinders is loose.
8. Tires are excessively worn, split, or have missing tire material.
9. Air filled tires are not filled to the operating pressure indicated on the tire.
10. Batteries have cracks or holes, uncapped cells, frayed cables, broken cable insulation, loose connections, or clogged vent caps.

Starting the Forklift

- Apply the foot brake and shift gears to neutral before turning the key.

Picking Up a Load

1. Square up on the center of the load and approach it straight on with the forks in the travel position.
2. Stop when the tips of your forks are about a foot from the load.
3. Level the forks and slowly drive forward until the load is resting against the backrest of the mast.
4. Lift the load high enough to clear whatever is under it.
5. Back up about one foot, and then slowly and evenly tilt the mast backwards to stabilize the load.

Putting a Load Down

1. Square up and stop about one foot from desired location.
2. Level the forks and drive to the loading spot.
3. Slowly lower the load to the floor.
4. Tilt the forks slightly forward so that you do not hook the load.
5. When the path behind you is clear of obstructions, back straight out until the forks have cleared the pallet.

Stacking One Load on Top of Another

1. Stop about one foot away from the loading area and lift the mast high enough to clear the top of the stack.
2. Slowly move forward until the load is squarely over the top of the stack.
3. Level the forks and lower the mast until the load is no longer supported by the forks.
4. Look over both shoulders for obstructions and back straight out if the path is clear.

Forklift Safety Rules

1. Do not exceed the lift capacity of the forklift. Read the lift capacity plate on the forklift if you are unsure.
2. Follow the manufacturer's guidelines concerning changes in the lift capacity before adding attachments, such as wedges, to a forklift.
3. Lift the load an inch or two to test for stability: If the rear wheels are not in firm contact with the floor, take a lighter load or use a forklift with a higher lift capacity.
4. Do not raise or lower a load while you are en-route. Wait until you are in the loading area and have stopped before raising or lowering the load.
5. After picking up a load, adjust the forks so that the load is tilted slightly backward for added stability.
6. Drive with the load at a ground clearance height of 4-6 inches at the tips and 2 inches at the heels in order to clear most uneven surfaces and debris.
7. Drive at a walking pace and apply brakes slowly to stop when driving on slippery surfaces such as icy or wet floors.
8. Approach angle railroad tracks at a 45

9. Do not drive over objects in your pathway.
10. Do not drive into an area with a ceiling height that is lower than the height of the mast or overhead guard.
11. Steer wide when making turns.
12. Do not drive up to anyone standing or working in front of a fixed object such as a wall.
13. Do not drive along the edge of an unguarded elevated surface such as a loading dock or staging platform.
14. Obey all traffic rules and signs.
15. Sound horn when approaching blind corners, doorways, or aisles to alert other operators and pedestrians.
16. Do not exceed a safe working speed of five miles per hour. Slowdown in congested areas.
17. Stay a minimum distance of three truck lengths from other operating mobile equipment.
18. Drive in reverse and use a signal person when your vision is blocked by the load.
19. Look in the direction that you are driving; proceed when you have a clear path.
20. Do not use bare forks as a man-lift platform.
21. Do not drive the forklift while people are on the attached man-lift platform.
22. Drive loaded forklifts forward up ramps.
23. Raise the forks an additional two inches to avoid hitting or scraping the ramp surface as you approach the ramp.
24. Drive loaded forklifts in reverse when driving down a ramp.
25. Drive unloaded forklifts in reverse going up a ramp and forward going down a ramp.
26. Do not attempt to turn around on a ramp.
27. Do not use "Reverse" to brake.
28. Lower the mast completely, turn off the engine, and set the parking brake before leaving your forklift.

HEAVY EQUIPMENT OPERATORS

Personal Protective Equipment

1. Wear hard hats, hearing protection and safety goggles while operating heavy equipment.
2. Do not wear hard hats that are dented or cracked.
3. Do not continue to work if your safety glasses become fogged. Stop work and clean the glasses until the lenses are clear and defogged.

General Hand Tool Safety

1. Keep the blade of all cutting tools sharp.
2. Do not use a tool if its handle has splinters, burrs, cracks, splits or if the head of the tool is loose.
3. Tag worn, damaged, or defective tools "Out of Service" and do not use them.
4. Do not use impact tools such as hammers or chisels that have mushroomed heads.
5. When handing a tool to another person, direct sharp points, and cutting edges away from yourself and the other person.
6. When using knives, shears or other cutting tools, cut in a direction away from your body.
7. Carry all sharp tools in a sheath or holster.
8. Do not perform "make-shift" repairs to tools.
9. Do not use "cheaters" on load binders or "boomers."
10. Do not carry tools in your hand when climbing. Carry tools in tool belts or hoist the tools to the work area using a hand line.
11. Do not throw tools from one location to another or from one employee to another.

Pneumatic Tools

1. Do not point a charged compressed air hose at bystanders or use it to clean your clothing.
2. Lock and/or tag tools "Out of Service" to prevent usage of the tool.
3. Do not use tools that have handles with burrs or cracks.
4. Do not use compressors if their belt guards are missing. Replace belt guards before using the compressor.
5. Turn the power switch of the tool to "Off" and let it come to a complete stop before leaving it unattended.
6. Disconnect the tool from the airline before making any adjustments or repairs to the tool.

Lifting Equipment

1. Do not use chain slings if links are cracked, twisted, stretched, or bent.
2. Do not shorten slings by using makeshift devices such as knots or bolts.
3. Do not use a kinked chain.
4. Protect slings from the sharp edges of their loads by placing pads over the sharp edges of the items that have been loaded.
5. Wear work gloves when handling rough, sharp-edged, or abrasive chains, cables, ropes, or slings.
6. Do not alter or remove the safety latch on hooks. Do not use a hook that does not have a safety latch, or if the safety latch is bent.

When Lifting

1. Do not place your hands between the sling and its load when the sling is being tightened around the load.
2. Lift the load from the center of hooks, not from the point.

GENERAL LABOR PERSONNEL

Site Safety

1. Do not start work until barricades, barrier logs, fill or other protection have been installed to isolate the work area from local traffic.
2. Reflective warning vests must be worn by traffic flagmen who are assigned to controlling traffic.
3. Do not approach any heavy equipment until the operator has seen you and has signaled to you that it is safe to approach.
4. Walk around or step over holes, rocks, roots, materials or equipment in your pathway.
5. Do not work outdoors during lightning storms.
6. Drink plenty of clear liquids during your breaks.
7. Take breaks in shaded areas.

Knives/Sharp Instruments

1. Use knives for the operation for which they are made.
2. Do not use knives that have broken or loose handles.
3. Do not use knives as screwdrivers, pry bars, can openers or ice picks.
4. When handling knife blades and other cutting tools, direct sharp points and edges away from you.
5. Cut in the direction away from your body when using knives.

Hand Tool Safety

General

1. Keep the blade of all cutting tools sharp.
2. Do not carry sharp or pointed hand tools such as screwdrivers, scribes, chisels or files in your pocket unless the tool or pocket is sheathed.
3. Tag worn, damaged, or defective tools "Out of Service" and do not use them.
4. Do not use a tool if its handle has splinters, burrs, cracks, splits or if the head of the tool is loose.
5. Do not use impact tools such as hammers, steel stakes, or chisels that have mushroomed heads.
6. Do not perform "make-shift" repairs to tools.
7. Do not throw tools from one location to another or from one employee to another.
8. Transport hand tools only in toolboxes or tool belts. Do not carry tools in your clothing.

Hammers

1. Do not use a hammer if your hands are oily, greasy, or wet.
2. Do not strike objects with the cheek of the hammer.
3. Do not strike one hammer against another hammer.

Pliers

1. Do not attempt to force pliers by using a hammer on them.
2. Do not use pliers that are cracked, broken, or sprung.

Saws

1. Keep control of saws by releasing downward pressure at the end of the stroke.
2. Do not use a saw that has dull saw blades.
3. Oil saw blades after each use.
4. Keep hands and fingers away from the saw blade while you are using the saw.
5. Do not carry a saw by the blade.
6. When using a handsaw, hold the work piece firmly against the worktable.

Electrical Powered Tools

1. Do not use power equipment or tools on which you have not been trained.
2. Keep power cords away from path of power saws.
3. Do not use cords that have splices, exposed wires, or cracked or frayed ends.
4. Do not carry plugged in equipment or tools with your finger on the switch.
5. Do not carry equipment or tools by the cord.
6. Turn the tool off before plugging or unplugging it.
7. Do not leave tools that are "On" unattended.
8. Do not handle or operate electrical tools when your hands are wet or when you are standing on wet floors or wet ground.
9. Do not use extension cords or other grounded three pronged power cords that have the ground prong removed or broken off.
10. Do not use an adapter that eliminates the ground such as a cheater plug.
11. Do not drive over, drag, step on or place objects on a cord.

General Power Saw Safety

1. Wear the prescribed personal protective equipment such as goggles, gloves, dust masks, and hearing protection when operating the power saw.
2. Do not use a power saw that has cracked, broken, or loose guards or other visible damage.
3. Turn off the saw before making measurements, adjustments, or repairs.
4. Keep your hands away from the exposed blade.
5. Operate the saw at full cutting speed with a sharp blade to prevent kickbacks.
6. If the saw becomes jammed, turn the power switch of the saw to "OFF" before pulling out the incomplete cut.
7. Do not alter the anti-kickback device or blade guard.
8. When using the power saw, do not reach across the cutting operation.
9. When using the power saw, do not hold the work piece against your body when making the cut.

Pneumatic Tools/Compressed Air

1. Do not point a compressed air hose at bystanders or use it to clean your clothing.
2. Do not use pneumatic tools that have handles with burrs or cracks.
3. Lock and/or tag tools "Out of Service" to prevent usage of the tool.
4. Do not use compressors if their belt guards are missing. Replace the belt guards before using the compressor.
5. Turn the power switch of the tool to "Off" and let it come to a complete stop before leaving it unattended.
6. Disconnect the tool from the airline before making any adjustments or repairs to the tool.

Personal Protective Equipment

1. Do not wear hard hats that are dented or cracked.
2. Do not continue to work if your safety glasses become fogged. Stop work and clean the glasses until the lenses are clear and defogged.
3. Wear your earplugs or earmuffs in areas posted "Hearing Protection Required."

4. Wear heavy leather-faced work gloves when handling wire-mesh.

Hazardous Materials

1. Follow the instructions on the label and in the corresponding Material Safety Data Sheet (MSDS) for each chemical product you will be using in your workplace.
2. Do not use protective clothing or equipment that has split seams, pinholes, cuts, tears, or other visible signs of damage.
3. Each time you use your gloves, wash them, before removing the gloves, using cold tap water and normal hand washing motion. Always wash your hands after removing the gloves.
4. Do not use chemicals from unlabeled containers or unmarked cylinders.
5. Always use chemical goggles and a face shield before handling chemicals labeled "Corrosive" or "Caustic."
6. Do not store chemical containers labeled "Oxidizer" with containers labeled "Corrosive" or "Caustic."
7. Do not smoke while handling chemicals labeled "Flammable".

Vehicle/Trailer Safety

Vehicle Safety

- A. Drive on the graded roadways that have been leveled for this purpose.
- B. Turn on low-beam headlights when driving on the site.
- C. Hold onto vehicle when stepping out of it onto loose ground, holes, or rocks.
- D. Tools and materials shall be secured to prevent movement when transported in the same compartment with employees.
- E. Do not exceed the maximum number of people for which the vehicle is designed to transport.
- F. Do not operate a loaded vehicle or load it, by means of cranes, power shovels, loaders, or similar equipment, if the vehicle does not have a cab shield and/or canopy to protect you from shifting or falling materials.

G. Fueling Vehicles

- Turn the vehicle off before fueling.
- Do not smoke while fueling a vehicle.
- Wash hands with soap and water if you spill gasoline on them.
- Do not carry extra fuel on any vehicle except in a properly mounted fuel tank approved by your employer.

H. Driving Rules

- Shut all doors and fasten your seat belt before moving the vehicle.
- Obey all traffic patterns and signs at all times.
- Maintain a three point contact using both hands and one foot or both feet and one hand when climbing into and out of vehicles.
- Drive up the slope or down the slope not across the slope.

Trailer Safety

- A. Set the parking brake in the towing vehicle and use wheel blocks to chock the wheels of the trailer before removing the kettle from the trailer.
- B. Permit no one to ride in the trailer.
- C. Use ramps to load and unload kettles and equipment from the trailer.
- D. Take slow, wide turns when towing trailers.
- E. Do not exceed the load capacity as posted on the trailer door of the trailer.
- F. Do not place all the heavy equipment on one side of the trailer.
- G. Secure equipment and fuel tanks to the vehicle with chains or straps to eliminate or minimize shifting of the load.
- H. Do not mount or dismount equipment on the traffic side.

LATHERS

Lifting Safety (Bags, Cans, Buckets)

- A. Position your feet 6 to 12 inches apart with one foot slightly in front of the other.
- B. Face the load.
- C. Bend at the knees, not at the back.
- D. Keep your back straight.
- E. Get a firm grip on the object with your hands and fingers. Use handles when present.
- F. Perform lifting movements smoothly and gradually; do not jerk the load.
- G. Hold objects as close to your body as possible.
- H. If you must change direction while lifting or carrying the load, pivot your feet and turn your entire body. Do not twist at the waist.
- I. Set down objects in the same manner as you picked them up, except in reverse.
- J. Slide materials to the end of the tailgate before attempting to lift them off a pick-up truck. Do not lift over the walls or tailgate of the truck bed.

Sandblasting

- A. Only authorized personnel may use blasting equipment.
- B. Wear your eye protection, respirator, and protective clothing when blasting.
- C. Visually inspect hoses or fittings on blasting equipment for wear and tear prior to use. Do not use if the hose or fitting is cracked or otherwise damaged.
- D. Post area, "Unauthorized personnel keep out".
- E. When working outdoors, keep shirts on to avoid bruises, dehydration, and sunburn.

Restoration Job and Asbestos is Suspected

- A. Do not perform asbestos removal operations, unless you have been trained, qualified, and certified in asbestos removal procedures.
- B. Use the respirator that has been fit tested and assigned to you by your supervisor.
- C. Always assume that materials used prior to 1976, such as plaster and blown insulation contain asbestos.
- D. Do not use sanders or power devices that may create dust or airborne particles.
- E. Do not dry scrape, bead blast or mechanically pulverize any existing plaster or blown insulation.

Fiberglass Batts or Sprayed-on Insulation

- A. Do not take work clothes home when exposed to sprayed-on insulation or fiberglass batts.
- B. Change your work clothes before leaving the job site.
- C. Place work clothes contaminated with fiberglass or sprayed-on insulation in a closed labeled container approved by your employer.
- D. Use your respirator when working with sprayed-on insulation or fiberglass.

Respiratory Protection

- A. Shave daily to prevent facial hair from interfering with the face seal of the respirator.
- B. Clean and return respirators to their carrying cases or cartons and store them in your locker or in a designated storage area as instructed by your employer when the work is completed.
- C. Only use the respirator that has been fitted and issued to you.

Infection Control

- A. Wash your hands after removing your gloves with soap or mild detergent and water before eating, smoking, using the toilet, or any areas of the body that may have contacted cementitious mixtures, pastes or spray-on insulation at the end of each workday.
- B. Use a mechanic's cream hand cleaner such as "Go-Jo" or "Humus" where water is not readily available.

FINISHING PERSONNEL-(tapping, bedding, sanding) Hazardous Materials

Mixing Cementitious Components

- A. Apply Vaseline to exposed skin surfaces on your arms and hands prior to handling plaster, lime or any cementitious mixtures.
- B. Do not handle lime or cementitious mixtures if you have open cuts or scratches on exposed skin surfaces such as your arms or hands.
- C. Use personal protective clothing or equipment such as canvas gloves and protective eyewear, to avoid cement poison or burns.
- D. Open doors, windows, and turn the power switch of the local exhaust fans to "On" when working indoors.

Applying Exterior Finishes (scratch coats, coquina, stucco installations, etc.)

- A. Do not use a metal ladder on rooftops or within 50 feet of electrical power lines.
- B. Do not block the walking surfaces of elevated working platforms, such as scaffolds, with tools or materials that are not being used.
- C. When working outdoors, drink plenty of fluids and keep shirts on to avoid dehydration and sunburn.

Using Joint Compounds

- A. Wear protective gloves when handling compounds or chemicals from containers labeled "Flammable," "Toxic," "Caustic" or "Poisonous" and wash your hands after removing the gloves.
- B. Follow the instructions on the label and in the corresponding Material Safety Data Sheet (MSDS) for each joint compound or chemical product used in your workplace.
- C. Each time you use your gloves, wash your gloves before removing them using cold tap water and normal hand washing motion. Always wash your hands after removing the gloves.
- D. Do not use joint/filler compounds or chemicals from unlabeled containers.
- E. Do not store chemical containers labeled "Oxidizer" with containers labeled "Corrosive" or "Caustic."
- F. Always use goggles and gloves when handling joint/filler compounds or chemicals labeled "Corrosive" or "Caustic."

Applying Finishes: Plaster, Coquina, Popcorn, or other

- A. Do not smoke or eat while performing stucco or "popcorn" finishes.
- B. Stand clear of mixing or blowing operations.
- C. Do not stand, work, or operate pneumatic equipment such as blowers with hoses within three feet of any unprotected roof opening or within five feet of any unprotected roof edge.

Job Site Safety

- A. Do not walk on or under partially demolished walls or floors.
- B. Stop working outdoors and seek shelter during lightning storms.
- C. Walk around or duck under protruding framing or ductwork and limbs.
- D. Do not walk on fallen trees; walk on the ground.
- E. Keep combustible liquids stored and covered in approved containers.

Personal Protective Equipment

- A. Wear your safety glasses when mixing plaster ingredients and additives, applying spackling, finishing ceilings, or sanding.
- B. Wear dust mask or respirator when emptying sacks of dry material such as additives for fire-proofing or plaster ingredients.
- C. Use lifelines, safety harnesses, or lanyards when you are working higher than 6 feet off the ground.
- D. Wear safety glasses while plastering, applying mud, or sanding.
- E. Wear safety goggles when using power tools or when applying a finishing material.

Manual Stacking and Handling Material

- A. Store all wallboard flat.
- B. Do not store boards vertically; this practice will damage the edges creating unstable stacks.
- C. Stand each board vertically on its side as close to the edge of the pile as possible, tilt the board toward the stack, and let the board drop freely on top of the stack.
- D. Do not allow boards to overhang more than an inch. Align flush all boards, to keep the boards from becoming unstable and topple on someone while restacking.
- E. Use a co-worker to assist handling the boards when stocking. Coordinate and communicate your movements with those of your co-worker.

Stacking Material (Sheet rock, gypsum, foam boards, etc.)

- A. When stacking panels by hand, position the panels sideways slightly in front of you, so you do not have to reach over your head or twist your body to lift these materials.
- B. Position panels to lean flat against a wall and do not wobble or slide.
- C. Push and slide panels along their edge or get assistance from a co-worker.

ELECTRICIANS

Hot Line Safety

1. Clean all protective line equipment after each use, prior to storage.
2. Wear rubber gloves or use hot sticks when removing tree branches, limbs, or similar objects from contact with high voltage lines, panels, or equipment.
3. Do not wear rubber protective gloves while climbing or descending a pole.
4. Wear 100% cotton or flame resistant shirts or jumpers (with sleeves rolled down) and protective hats when working on or near live parts, lines, and panels or when climbing poles.
5. Wear body belts with straps or lanyards when working at an elevated position (poles, towers, etc.).
6. Visually inspect body belts and straps before use for defects, wear, and damage.

7. When working with lines of 600 volts or more:
 - Wear rubber gloves or use hot sticks when placing protective equipment on/around energized voltage conductors.
 - Do not work on the line that is removed from service until the line is cleared, tagged, tested, and grounded.
 - Treat bare wire communication conductors on structures as energized lines unless they are protected by insulated conductors.
8. Treat bare wire communication conductors on power poles and structures as energized lines (with voltages in excess of 600 volts) unless the conductors are protected by insulating materials.
9. Do not remove any ground until all employees are clear of the temporary grounded lines or equipment.
10. After a capacitor has been disconnected from its source of supply, wait five minute before short-circuiting and grounding it.
11. Do not contact the terminals, jumpers, or line wires connected directly to capacitors until the capacitors have been short-circuited and/or grounded.
12. Visually inspect and wipe down all hot line tools each day before use.
13. Do not wear rubber gloves with protectors while using hot line tools.
14. Do not use defective hot line tools. Mark them as defective and turn them in for repair or replacement.

Stringing/Removing Deenergized Conductors

1. Keep conductors that are being strung in or removed under positive control to prevent accidental contact with energized circuits.
2. Do not exceed the load rating for stringing lines, pulling lines, sock connections or load-bearing hardware and accessories.
3. Do not use defective pulling lines or defective accessories. Mark the defective items and turn them in for repair or

replacement.

4. Do not use conductor grips on wire ropes unless the grips are designed for that particular purpose.
5. If an existing line that crosses over a conductor is to be deenergized, ground the line on both sides of the crossing or treat the conductor being crossed as energized.

Bus/Bus Room Safety

1. Do not enter or work in the bus room alone.
2. Do not leave the bus room doors open.
3. Do not carry any tools or materials above your waist while in the bus room.
4. Do not work on any bus, bus structure, cable, or disconnect switch unless it is grounded.

General Electrical Device/Fixture Installation Safety

1. Assume all electrical wires as live wires.
2. Turn the main switch to "Off" before removing and replacing power fuses.
3. Do not wear watches, rings or other metallic objects that could act as conductors of electricity around electrical circuits.
4. Before leaving the job, test insulators, and equipment to ensure they are free from defects.
5. Do not work near any circuit that is in service without first installing barricades approved by your supervisor.
6. Do not touch field brushes or a synchronous motor until the motor is up to synchronous speed and the field switch is closed.

PAINTING PERSONNEL

Painting Safety

1. Store rags that have oil or paint on them in closed metal containers labeled "oily rags".
2. Press the pressure relief valve on painting canisters and painting guns prior to disconnecting them.
3. Do not store food or eat where spray painting is being performed.
4. Close the lids of containers of paint and thinner tightly after each use or when not being used.

Blasting Safety

1. Only blasters may use blasting equipment.
2. Visually inspect hoses or fittings on blasting equipment for wear and tear prior to use. Do not use if the hose or fitting is cracked or otherwise damaged.
3. Do not use compressed air to clean equipment or yourself.

Spray Painting Safety

1. Do not point the spray gun toward any part of your body or at anyone else.
2. Store rags that have paint on them in closed metal containers labeled "oily rags."
3. Press the pressure relief valve on painting canisters and painting guns prior to disconnecting them.
4. Do not store food or eat where spray painting is being performed.
5. Close the lids of containers of paint and thinner tightly after each use or when not being used.
6. Return containers of thinners, mineral spirits and other liquids labeled "Flammable" to the storage cabinet labeled "Flammable Storage," when painting is finished.
7. Always wash your hands with soap and water after using paints or other toxic solvents to remove paint from your skin.

PLUMBERS (MASTERS and APPRENTICES)

General Installation Rules & Guidelines

1. Do not begin working until barricades, warning signs or other protective devices have been installed to isolate the work area from local traffic.
2. Do not walk under partially demolished walls or floors.

3. Stop working outdoors and seek shelter during lightning storms.
4. When working outside, keep shirts on to avoid dehydration and sunburn.
5. Drink plenty of clear liquids during your breaks.
6. If you discover a wasp nest or bee hive while installing or servicing equipment, use the long distance aerosol insecticide labeled "Wasp and Bee Insecticide" to spray the nest. Test with the stick or pole once again to ensure that all bees/wasps are gone before continuing work.
7. Seek first aid immediately if bitten or stung by wasps or bees. Follow First Aid Procedures.
8. Do not handle caterpillars or other insects with your bare hands.
9. Do not use a metal ladder within 50 feet of electrical power lines.
10. Do not block the walking surfaces of elevated working platforms, such as scaffolds, with tools or materials that are not being used.
11. Do not stand on sinks, toilets, or cabinets; use a stepladder.
12. Do not work on open sided floors, elevated walkways, or elevated platforms if there are no guardrails in place.
13. Do not handle hot items such as hot water heaters or water/steam lines with your bare hands; use cloth gloves.
14. Open the gate valve to release the pressure from the steam lines and turn off the boiler before servicing piping equipment.

Work Clothing and Personal Protective Equipment

1. Wear the face shield over your goggles or safety glasses during open furnace, welding, soldering or gas cutting operations.
2. Do not continue to work if your safety glasses become fogged. Stop work and clean the glasses until the lenses are clear and defogged.
3. Wear the welding helmet or welding goggles during welding operations.
4. Wear the dielectric gloves when working on electric current.
5. Wear your earplugs or earmuffs in areas posted "Hearing Protection Required."
6. Safety goggles must be worn while welding or cutting metal.
7. Do not wear long sleeve shirts that do not have button-down cuffs.
8. Do not wear jewelry or coats with metal zippers to work.

Respirators

1. Wear the respirator provided by your supervisor for your assigned duties.
 2. Shave daily to prevent facial hair from interfering with the face seal of the respirator.
 3. Clean and disinfect your respirator with detergent solution and clean water after each use.
 4. Do not wear contact lenses when wearing a respirator. Use optical inserts acquired by your supervisor.
 5. Return respirators to carrying case or carton and store in your locker or storage area when the work is completed.
 6. Prior to each use, inspect the respirators for missing or distorted inhalation and exhalation valves, or cracked face pieces. Do not use if any of these conditions are found.
 7. Do not use respirator that has cracks, excessive dirt on the face piece, and loss of elasticity in the straps, missing gaskets, and kinks in air supply hoses.
 8. Perform a fit test prior to use.
- First, position face piece comfortably over face and pull all straps tight. Do not wear face piece if it does not allow you to talk, if it does not fit snug over nose bridge or if it slips. Close off the inlet of the canister, cartridges or filters with the palm of your hands or replace the seals and inhale slightly and hold for 10 (ten) seconds. If face piece remains slightly collapsed and no inward leaking is detected, the respirator is tight enough. Use your other hand to detect air leaks around face seal. (Negative pressure test).
 - Second, close off the exhalation valve and blow into face piece gently. Use hands to feel any air leaking out of the seal between face piece and face. If no outward leaking is detected, the respirator is tight enough. (Positive pressure test)
9. Only use respirator that has been issued to you.

Confined Space Entry (sewers, etc.)

1. Do not enter the sewers or other confined spaces without reading and following this "confined space entry procedure."
2. Obtain a confined space entry permit from your supervisor before entering the confined space.
3. Do not enter the confined space unless an assigned observer or lookout person posted at the entrance. If you are assigned as the outside observer, do not go inside the confined space under any circumstances and keep the entrant in your view at all times.
4. Place furnaces and space heaters in a level position on the downhill lower side of the manhole.
5. Do not throw materials into or out of manholes. Place materials in a receptacle and hoist them in and out by means of a rope.
6. Do not leave tools and/or materials on the ground around a manhole opening.
7. Use survey equipment such as an "organic vapor meter" to test and monitor the confined space for oxygen deficiency and explosive or hazardous gases/fumes. If the organic vapor meter reading for the explosive gases is above 10% of the LEL and if the oxygen reading is below 19.5% or greater than 23.5%, do not enter the confined space.
8. Turn "off" disconnect, or lock and tag all systems that affect or make operational the confined space prior to entry.
9. Do not perform hot work such as electric or gas welding or cutting in or on a confined space until the atmosphere has been determined to be safe.
10. Use mechanical forced air ventilation when open flames or torches are used in a confined space.

Fabrication Operations

General Machine Safety

1. Replace the guards before starting machines, or after making adjustments or repairs to the machine.
2. Do not remove, alter, or bypass any safety guards or devices when operating any piece of equipment or machinery.
3. Do not wear loose clothing or jewelry around moving machinery.
4. Long hair must be contained under a hat or hair net, regardless of gender.
5. Read and obey safety warnings posted on or near any machinery.
6. Do not try to stop a work piece as it goes through any machine. If the machine becomes jammed, unplug it before clearing the jam.
7. Do not use metal working equipment such as grinders, sanders, or beveling machines if they do not have safety guards.
8. Clamp work when using saws or cutting tools.

ROOFING PERSONNEL

Housekeeping

1. Do not place materials such as tools, boxes, buckets, or trash in walkways and passageways.
2. Do not kick objects out of your pathway; pick them up or push them out of the way.
3. Do not throw matches, cigarettes or other smoking materials into trash bins.
4. Do not store or leave items on stairways.
5. Do not block or obstruct stairwells, exits, or accesses to safety and emergency equipment such as fire extinguishers or fire alarms.
6. Do not leave loose tools, lunch boxes or other items on rooftop. Return tools to their storage places after use.
7. Keep walking surfaces of elevated working platforms, such as scaffolds and equipment access pads on roofs, clear of tools and materials that are not being used.
8. Remove protruding nails or bend them down into the lumber by using a claw hammer.
9. Do not use gasoline for cleaning purposes.
10. Sweep up scraps and debris from around equipment such as drill presses, punches, or power shears by using a broom and a dustpan.
11. Do not drop debris through roof top openings unless the area below has been barricaded at least 6 feet out from all edges of the opening.
12. Do not use gasoline for cleaning purposes.

Lifting Procedures

General

1. Plan the move before lifting; remove obstructions from your chosen pathway.
2. Test the weight of the load before lifting by pushing the load along its resting surface.
3. If the load is too heavy or bulky, use lifting and carrying aids such as hand trucks, dollies, pallet jacks, and carts or get assistance from a co-worker.
4. If assistance is required to perform a lift, coordinate and communicate your movements with those of your co-worker.
5. Never lift anything if your hands are greasy or wet.
6. Wear protective gloves approved by your supervisor when lifting objects with sharp corners or jagged edges.
7. Do not lift an object from the floor to a level above your waist in one motion. Set the load down on a table or bench and then adjust your grip before lifting it higher.

When Lifting

1. Position your feet 6 to 12 inches apart with one foot slightly in front of the other.
2. Face the load.
3. Bend at the knees, not at the back.
4. Keep your back straight.
5. Get a firm grip on the object with your hands and fingers. Use handles when present.
6. Perform lifting movements smoothly and gradually; do not jerk the load.
7. Hold objects as close to your body as possible.
8. If you must change direction while lifting or carrying the load, pivot your feet and turn your entire body. Do not twist at the waist.
9. Set down objects in the same manner as you picked them up, except in reverse.
10. Slide materials to the end of the tailgate before attempting to lift them off a pick-up truck. Do not lift over the walls or tailgate of the truck bed.

Ladder and Step Ladder Safety

1. Do not use ladders that have loose rungs, cracked or split side rails, missing rubber footpads or are otherwise visibly damaged.
2. Keep ladder rungs clean of grease. Remove buildup of material such as dirt, debris, or mud.
3. When performing work from a ladder, face the ladder and do not lean backward or sideways from the ladder.
4. Do not stand on the top two rungs of any ladder.
5. Do not stand on a ladder that wobbles or that leans to the left or right.
6. Do not try to "walk" a ladder by rocking it. Climb down the ladder, and then move it.
7. One person shall be on the ladder at a time.
8. Do not use a ladder as a horizontal platform.
10. Secure the ladder in place by having another employee hold it.
12. Face the ladder when climbing up or down.
13. Maintain a three-point contact by keeping both hands and one foot or both feet and one hand on the ladder at all times when climbing up or down.
14. Do not carry items in your hands while climbing up or down a ladder.
15. Read and follow the manufacturer's instructions label affixed to the ladder if you are unsure how to use the ladder.
16. Do not use a metal ladder on rooftops or within 50 feet of electrical power lines.
17. Do not jump from rooftops, chimneystacks, or ladders.
18. Do not use scrap lumber, bundles of shingles, or any other types of makeshift stacks or bundles of building materials as improvised climbing devices.

Personal Protective Equipment

1. Do not drill holes in or paint your hard hat.
2. Do not wear hard hats that are dented or cracked.
3. Wear the chemical goggles when using, applying, or handling chemical liquids or powders from containers labeled "Caustic" or "Corrosive."
4. Do not continue to work if your safety glasses become fogged. Stop work and clean the glasses until the lenses are clear.

and defogged.

5. Wear your earplugs or earmuffs in areas posted "Hearing Protection Required."
6. When handling hot tar, wear clothing made of cotton or non-synthetic fibers. Wear long sleeve shirts, long pants, and gloves.
7. Use lifelines, safety harnesses, or lanyards when you are working higher than 6 feet off the ground.
8. Wear safety goggles while reaming, drilling, welding or cutting metal.
9. Wear leatherwork gloves when handling rough, sharp-edged, or abrasive material such as chains, cables ropes, or slings. Wear snug fitting gloves with cuffs that will extend up under the buttoned shirtsleeves.
10. Wear laced high-top work boots at all times except when working on roofs steeper than 4:12 or when applying special roofing materials that require other types of shoes.
11. Wear your hard hats at all times when someone is working above you.
12. Wear safety goggles when tearing off roofs, when using power tools or when installing coal tar pitch roofing material.
13. Use face cream when working with coal tar pitch.
14. Do not take work clothes home when exposed to coal tar pitch volatiles.
15. Change your work clothes before leaving the job site.
16. Place work clothes contaminated with coal tar pitch volatiles in a closed labeled container approved by your employer.

When Respirators are Provided

1. Shave daily to prevent facial hair from interfering with the face seal of the respirator.
2. Do not wear contact lenses when wearing a respirator.
3. Clean and return respirators to their carrying cases or cartons and store them in your locker or in a designated storage area as instructed by your employer when the work is completed.
4. Only use the respirator that has been fitted and issued to you.
5. Use your respirator when working with coal tar pitch.

Infection Control

1. Wash your hands after removing your gloves with soap or mild detergent and water before eating, smoking, using the toilet, or any areas of the body that may have contacted these volatiles at the end of each workday.
2. Use a mechanic's cream hand cleaner such as "Go-Jo" or "Humus" where water is not readily available.

Scaffolding

1. Follow the manufacturer's instructions when erecting the scaffold.
2. Do not work on scaffolds outside during stormy or windy weather.
3. Do not climb on scaffolds that wobble or lean to one side.
4. Initially inspect the scaffold prior to mounting it. Do not use a scaffold if any pulley, block, hook, or fitting is visibly worn, cracked, rusted, or otherwise damaged. Do not use a scaffold if any rope is frayed, torn, or visibly damaged.
5. Do not use any scaffold tagged "Out of Service."
6. Do not use unstable objects such as bundles of shingles, steel drums or cans, crates, loose brick or concrete blocks to support scaffolds or planks.
7. Do not work on platforms or scaffolds unless they are fully planked.
8. Do not use a scaffold unless guardrails and all flooring are in place.
9. Do not use strips of felt or any building material as a makeshift guardrail. Utilize guardrail system as outlined per manufacturers' instructions.
10. Level the scaffold after each move. Do not extend adjusting leg screws more than 12 inches.
11. Do not walk or work beneath a scaffold unless a wire mesh has been installed between the mid-rail and the toe board or planking.
12. Use your safety belts and lanyards when working on scaffolding at a height of 10 feet or more above ground level. Attach the lanyard to a secure member of the scaffold.
12. Do not climb the cross braces for access to the scaffold. Use the ladder.
13. Do not jump from, to or between scaffolding.
14. Do not slide down cables, ropes or guys used for bracing.

15. Keep both feet on the decking. Do not sit or climb on the guardrails.
16. Do not lean out from the scaffold. Do not rock the scaffold.
17. Keep the scaffold free of roofing material scraps, loose tools, and other obstructions.
18. Do not throw anything "overboard" unless a spotter is available. Use the debris chutes or lower things by hoist or by hand.
19. Do not move a mobile scaffold if anyone is on the scaffold.
20. Prior to using a rolling scaffold, chock the wheels with wheel blocks and lock them by using your foot to depress the wheel lock.

Lifting Equipment (chains, cables, ropes, slings, etc.)

1. Do not use chain slings if links are cracked, twisted, stretched, or bent.
2. Fabricate all wire in wire rope slings by using thimbles; do not form eyes by using wire clips or knots.
3. Do not shorten slings by using makeshift devices such as knots or bolts.
4. Do not use a kinked chain.
5. Protect slings from the sharp edges of their loads by placing pads over the sharp edges of the items that have been loaded.
6. Do not place your hands between the sling and its load when the sling is being tightened around the load.
7. Wear work gloves when handling rough, sharp-edged, or abrasive material such as chains, cables, ropes, or slings.
8. Do not alter or remove the safety latch on hooks. Don't use a hook that does not have a safety latch or if the safety latch is bent.
9. Lift the load from the center of the hooks, not from the point.
10. Do not use a ground-operated hoist in which the safety latch on the hook has been removed, is bent, or is otherwise visibly damaged.

Forklift Safety

General

1. Only authorized and trained personnel are allowed to operate the forklifts.
2. Apply the foot brake and shift gears to neutral before turning the key.
3. Do not use bare forks as a man-lift platform.
4. Steer the forklift wide when making turns.
5. Sound the forklift horn when approaching blind corners, doorways, or aisles to alert other operators and pedestrians.

Lifting

1. Do not exceed the lift capacity of the forklift. Read the lift capacity plate on the forklift if you are unsure.
2. Follow the manufacturer's guidelines concerning changes in the lift capacity before adding an attachment to a forklift.
3. Lift the load an inch or two to test for stability; if the rear wheels are not in firm contact with the floor, take a lighter load or use a forklift that has a higher lift capacity.
4. Do not raise or lower a load while you are enroot. Wait until you are in the loading area and have stopped before raising or lowering the load.
5. After picking up a load, adjust the forks so that the load is tilted slightly backward for added stability.
6. Raise the forks an additional two inches to avoid hitting or scraping the ramp surface as you approach the ramp.
7. Do not drive the forklift while people are on the attached man-lift platform.
8. Drive unloaded forklifts in reverse when going up a ramp and forward when going down a ramp.
9. Drive a loaded forklift in a forward gear when going up a ramp. Upon approaching the ramp, raise the forks an additional two inches to avoid hitting or scraping the ramp surface.
10. Do not attempt to turn the forklift around on a ramp.
11. Do not use a gear for the opposite direction of travel as a means to slow down or stop the forklift.
12. Lower the mast completely, turn the engine off, and set the parking brake before leaving your forklift.

Cranes and Hoists

1. Do not use load hooks or chains that are cracked, bent, elongated, or broken.

2. Do not use cranes that do not have their rated load capacity indicated on each side of the crane or on its load block.
3. Passengers are not permitted to ride inside the operator's cab of a truck crane.
4. Keep crane windows clean. Do not use a crane if its windows are broken.
5. Do not exceed posted weight limits on hoists.
6. Do not operate a crane on soft ground without cribbing and mats.
7. Fully extend outriggers before attempting a lift.
8. Stay outside the barricades of the posted swing radius.
9. Do not perform any crane retrofits or modifications without the manufacturer's approval.
10. Do not leave the crane unattended with a hoisted load.
11. Do not hoist loads over people.
12. Do not drive on the road shoulders.
13. Wear high visibility vests.
14. Wear the prescribed personal protective equipment such as hardhat, goggles, gloves, dust masks, and hearing protection when operating a hoist.
15. Replace the belts, gears or rotating shaft guards after servicing a crane; do not use the crane if guards are missing from these areas.

Specific Operations

Picking up a Load

1. "Square up" on the center of the load and approach it straight on with the forks in the travel position.
2. Stop when the tips of your forks are about a foot from the load.
3. Level the forks and slowly drive forward until the load is resting against the backrest of the mast.
4. Lift the load high enough to clear whatever is under it.
5. Back up about one foot, and then slowly and evenly tilt the mast backwards to stabilize the load.

Putting a Load Down

1. "Square up" and stop about one foot from the desired location.
2. Level the forks and drive to the loading spot.
3. Slowly lower the load to the floor.
4. Tilt the forks slightly forward so that you do not hook the load.
5. When the path behind you is clear of obstructions, back straight out until the forks have cleared the pallet.

Stacking One Load on Top of Another

1. Stop about one foot away from the loading area and lift the mast high enough to clear the top of the stack.
2. Slowly move forward until the load is squarely over the top of the stack.
3. Level the forks and lower the mast until the forks no longer support the load.
4. Look over both shoulders for obstructions and back straight out if the path is clear.

Job Site Safety

1. Do not walk under partially demolished walls or floors.
2. Stop working outdoors and seek shelter during lightning storms.
3. Do not begin working until barricades, warning signs or other protective devices have been installed to isolate the work area.
4. Do not throw or toss debris outside barricaded areas.
5. Walk around or step over holes, rocks, and roots in your pathway.
6. Stay clear of all trucks, forklifts, cranes, and other heavy equipment when in operation.
7. Do not approach any heavy equipment until the operator has seen you and has signaled to you that it is safe to approach.
8. Walk around or duck under protruding branches and limbs.
9. Do not walk on fallen trees; walk on the ground.
10. Do not clear brush by hand within 100 ft. of heavy equipment operations.

11. Keep combustible liquids stored and covered in approved containers.

Vehicular Safety (trucks and all-terrain vehicles)

General

1. Drive on the graded roadways that have been leveled for this purpose.
2. Turn on low-beam headlights when driving on the site.
3. Drive up the slope or down the slope, not across the slope.
4. Hold onto vehicle when stepping out of it onto loose ground, holes, or rocks.
5. Tools and materials shall be secured to prevent movement when transported in the same compartment with employees.
6. Do not exceed the maximum number of people for which the vehicle is designed to transport.
7. Do not operate a loaded vehicle or load it, by means of cranes, power shovels, loaders, or similar equipment, if the vehicle does not have a cab shield and/or canopy to protect you from shifting or falling materials.
8. Do not carry extra fuel on any vehicle except in a properly mounted fuel tank approved by your employer.

Fueling Vehicles

1. Turn the vehicle off before fueling.
2. Do not smoke while fueling a vehicle.
3. Wash hands with soap and water if you spill gasoline on them.

Driving Rules

1. Shut all doors and fasten your seat belt before moving the vehicle.
2. Obey all traffic patterns and signs at all times.
3. Maintain a three point contact using both hands and one foot or both feet and one hand when climbing into and out of vehicles.
4. Drive up the slope or down the slope not across the slope.

Trailer Safety

1. Set the parking brake in the towing vehicle and use wheel blocks to chock the wheels of the trailer before removing the kettle from the trailer.
2. Permit no one to ride in the trailer.
3. Use ramps to load and unload kettles and equipment from the trailer.
4. Take slow, wide turns when towing trailers.
5. Do not exceed the load capacity as posted on the trailer door of the trailer.
6. Do not place all the heavy equipment on one side of the trailer.
7. Secure equipment and fuel tanks to the vehicle with chains or straps to eliminate or minimize shifting of the load.
8. Do not mount or dismount equipment on the traffic side.

Hand/Power Tool Safety

General

1. Use tied off containers to keep tools from falling off scaffolds and other elevated work platforms.
2. Carry all sharp tools in a sheath or holster.
3. Tag worn, damaged, or defective tools "Out of Service" and do not use them.
4. Do not use a tool if its handle has splinters, burrs, cracks, splits or if the head of the tool is loose.
5. Do not use impact tools such as hammers, chisels, punches, or steel stakes that have mushroomed heads.
6. Do not carry sharp or pointed hand tools such as screwdrivers, scribes, aviation snips, scrapers, chisels or files in your pocket unless the tool or your pocket is sheathed.
7. Do not perform "make-shift" repairs to tools.
8. Do not use "cheaters" on load binders or "boomers."
9. Do not carry tools in your hand when you are climbing. Carry tools in tool belts or hoist the tools to the work area using a hand line.
10. Do not throw tools from one location to another, from one employee to another or from scaffolds or other elevated

platforms.

11. Only transport hand tools in toolboxes or tool belts. Do not carry tools in your clothing.

Hammers

1. Use a claw hammer for pulling nails.
2. Do not strike nails or other objects with the "cheek" of the hammer.
3. Do not strike a hardened steel surface, such as a cold chisel, with a claw hammer.
4. Do not strike one hammer against another hammer.
5. Do not use a hammer if your hands are oily, greasy, or wet.
6. Do not use a hammer as a wedge, a pry bar or for pulling large spikes.

Snips

1. Wear safety glasses or safety goggles when using snips to cut materials.
2. Wear work gloves when cutting materials with snips.
3. Do not use straight cut snips to cut curves.
4. Keep the blade aligned by tightening the nut and bolt on the snips.
5. Do not use snips as a hammer, screwdriver, or pry bar.
6. Engage the locking clip on the snips after use.

Screwdrivers

1. Always match the size and type of screwdriver blade to fit the head of the screw.
2. Do not hold the work piece against your body while using a screwdriver.
3. Do not put your fingers near the blade of the screwdriver when tightening a screw.
4. Use an awl, drill or a nail to make a starting hole for screws.
5. Do not force a screwdriver by using a hammer or pliers on it.
6. Do not use a screwdriver as a punch, chisel, pry bar or nail puller.
7. Do not carry a screwdriver in your pocket.
8. Do not use a screwdriver if your hands are wet, oily, or greasy.
9. When using a spiral ratchet screwdriver, push down firmly and slowly.

Powder Actuated Tools

1. Wear impact resistant safety goggles or face shields when operating any powder actuated tools.
2. Do not attempt to fasten through a pre-drilled hole unless the powder actuated tool has a hole locator.
3. Keep your head and body behind the powder-actuated tool when firing it.
4. Before using powder actuated tools do not alter, bypass or remove the shield or guard at the muzzle end of the powder-actuated tool.
5. Do not load a powder-actuated tool until you are ready to fire it.

Hydraulic/Pneumatic Tools

1. Do not point a compressed air hose at bystanders or use it to clean your clothing.
2. Lock and/or tag tools "Out of Service" to prevent usage of the tool.
3. Do not use tools that have handles with burrs or cracks.
4. Do not use compressors if their belt guards are missing. Replace belt guards before use.
5. Turn the tool "off" and let it come to a complete stop before leaving it unattended.
6. Disconnect the tool from the airline before making any adjustments or repairs to the tool.

Heat Exhaustion/Sun Exposure

- Keep shirts on to avoid dehydration and sunburn.

Knives/Sharp Instruments

1. When handling knife blades and other cutting tools, direct sharp points and edges away from you.
2. Cut in the direction away from your body when using knives.
3. Use the knife that has been sharpened; do not use knives that have dull blades.
4. Use knives for the operations for which they are made.
5. Do not use knives that have broken or loose handles.
6. Do not use knives as screwdrivers, pry bars, or can openers.
7. Do not pick up knives by their blades.
8. Carry knives with their tips pointed towards the ground.
9. Do not carry knives, scissors or other sharp tools in your pockets or an apron unless they are first placed in their sheath or holder.
10. Do not attempt to catch a falling knife.
11. Store knives in knife blocks or in sheaths after using them.

Electrical Safety

1. Do not use power equipment or tools on which you have not been trained.
2. Keep power cords away from the path of drills, metal shears, power presses, grinders, and other tools or equipment that can splice or cut the power cord.
3. Do not use cords that have splices, exposed wires, or cracked or frayed ends.
4. Do not carry plugged in equipment or tools with your finger on the switch.
5. Do not carry equipment or tools by the cord.
6. Disconnect the tool from the outlet by pulling on the plug, not the cord.
7. Turn the tool off before plugging or unplugging it.
8. Do not leave tools that are "On" unattended.
9. Do not handle or operate electrical tools when your hands are wet or when you are standing on wet floors.
10. Do not operate spark inducing tools such as grinders, drills, or saws near containers labeled "Flammable" or in an explosive atmosphere such as a paint spray booth.
11. Turn off the electrical tool and unplug it from the outlet before attempting repairs or service work. Tag the tool "Out of Service."
12. Do not use extension cords or other three pronged power cords that have a missing prong.
13. Do not use an adapter such as a cheater plug that eliminates the ground.
14. Do not plug multiple electrical cords into a single outlet.
15. Do not run extension cords through doorways, through holes in ceilings, walls, or floors.
16. Do not stand in water or on wet surfaces when operating power hand tools or portable electrical appliances.
17. Do not use a power hand tool to cut wet or water soaked building materials.
18. Do not use a power hand tool while wearing wet cotton gloves or wet leather gloves.
19. Never operate electrical equipment barefooted. Wear rubber-soled or insulated work boots.
20. Do not operate a power hand tool or portable appliance that has a frayed, worn, cut, improperly spliced, or damaged power cord.
21. Do not operate a power hand tool or portable appliance if a prong from the three-pronged power plug is missing or has been removed.
22. Do not operate a power hand tool or portable appliance that has a two-pronged adapter or a two-conductor extension cord.
23. Do not operate a power hand tool or portable appliance while holding a part of the metal casing or while holding the extension cord in your hand. Hold all portable power tools by the plastic handgrips or other nonconductive areas designed for gripping purposes.

Hazardous Materials

When Using Chemicals to Seal Metals

1. Wear protective gloves when handling chemicals from containers labeled "Flammable," "Toxic," "Caustic" or "Poisonous" and wash your hands after removing the gloves.
2. Follow the instructions on the label and in the corresponding Material Safety Data Sheet (MSDS) for each chemical

product used in your workplace.

3. Each time you use your gloves, wash your gloves before removing them using cold tap water and normal hand washing motion. Always wash your hands after removing the gloves.
4. Do not use chemicals from unlabeled containers and unmarked cylinders.
5. Do not perform "hot work" such as welding, metal grinding, or other spark producing operations within 50 feet of containers labeled "Flammable" or "Combustible."
6. Do not drag containers labeled "Flammable."
7. Do not store chemical containers labeled "Oxidizer" with containers labeled "Corrosive" or "Caustic."
8. Always use chemical goggles and a face shield before handling chemicals labeled "Corrosive" or "Caustic."

Power Hoist Safety

1. Use manufacturer approved counter weights to secure the hoist. Do not use roofing materials such as rolls of felt or bundles of shingles,
2. Do not exceed the manufacturer's recommended load capacity limits.
3. Only trained personnel, approved by the employer, are allowed to operate a power hoist.
4. Use the power hoist in an area that permits the operator to stand clear of the load at all times.
5. Use safety hooks or shackles to attach the load whenever possible.
6. Use 'tag lines' to control the load when necessary.
7. Keep your fingers and clothing clear of hoist machinery.
8. Do not attempt adjustments while the hoist is running.

Portable Welding Equipment

1. Wear a welding helmet or welding goggles during welding operations.
2. Do not use personal or employee-owned power tools and portable appliance while at work.
3. Do not perform welding tasks while wearing wet cotton gloves or wet leather gloves.
4. Insulated work gloves are required for all welders when using welding equipment.
5. Do not use welding apparatus if power plug is cut, frayed, split or otherwise visibly damaged or modified.
6. When replacing power plugs and cords of welding apparatus, always check to ensure that the ground wire is connected and the power plug prongs are not worn off, allowing the plug to be inserted backward.

Compressed Gas Cylinders

Storage and Handling

1. Do not handle oxygen cylinders if your gloves are greasy or oily.
2. Store all cylinders in the upright position.
3. Place valve protection caps on gas cylinders that are in storage or not in use.
4. Do not lift cylinders by the valve protection cap.
5. Do not store compressed gas cylinders in areas where they can come in contact with chemicals labeled "Corrosive."
6. Place cylinders on a cradle, sling board, pallet or cylinder basket to hoist them.
7. Do not place cylinders against electrical panels or live electrical cords where the cylinder can become part of the circuit.
8. Do not use a flame to check for propane cylinder leak, use a leak or monitor detector.

Use of Cylinders

1. Do not use dented, cracked, or other visually damaged cylinders.
2. Use only an open ended or adjustable wrench when connecting or disconnecting regulators and fittings.
3. Do not transport cylinders without first removing regulators and replacing the valve protection caps.
4. Close the cylinder valve when work is finished, when the cylinder is empty or at any time, the cylinder is moved.
5. Do not store oxygen cylinders near fuel gas cylinders such as propane or acetylene or near combustible material such as oil or grease.
6. Stand to the side of the regulator when opening the valve.
7. If a cylinder is leaking around a valve or a fuse plug, move it to an outside area away from where work is performed and tag it to indicate the defect.
8. Do not hoist or transport cylinders by means of magnets or choker slings.

9. Do not use compressed gas to clean the work area, equipment, or yourself.
10. Do not remove the valve wrench from acetylene cylinders while the cylinder is in use.
11. Open compressed gas cylinder valves slowly. Open fully when in use to eliminate possible leakage around the cylinder valve stem.
12. Purge oxygen valves, regulators, and lines before use.

Torch on Applications

1. "Blow Out" hoses before attaching the torch.
2. Inspect hoses and torches before use. Replace damaged, burned, worn, or leaking parts.
3. Use a pressure gauge on every regulator. Do not use an adjustable regulator with a higher-pressure range than the original regulator that came with the torch.
4. Never face the gauge while opening the cylinder valve.
5. Before lighting a torch, purge the hose, adjust the working pressures, then use a friction lighter to ignite the gases. Do not use matches or a cigarette lighter.
6. Do not use oil, grease or other lubricants on the regulator.
7. When shutting off the torch, close the gas cylinder valve first and let the remaining gas burn out of the hose before closing off the torch valve.
8. Never overfill a gas cylinder. It could explode.
9. Use only hoses listed for liquid petroleum (LP) gas.
10. Use soap solution to test for gas leaks before lighting.
11. Visually check and ensure that the flow of gas through the regulator is flowing in the proper direction. Directional flow is stamped on the regulator.
12. To keep 'frosting' from occurring, increase the size of the bottle or cylinder.
13. Secure propane tanks in an upright position and place them at least 10 feet from the open flame.
14. Keep non-applicators at least 10 feet from the flame.
15. Keep vent in pressure regulator clear at all times.
16. When shutting off the torch, close the propane cylinder valve first and let the remaining gas burn out of the hose.
17. Do not leave a lighted torch unattended.
18. Do not heat a cylinder to increase pressure.
19. Place a fire extinguisher near you, but away from the torch and other parts of LP gas equipment, when performing torch on operations.
20. Do not lay an operating torch over the edge of a roof.
21. Do not use a trowel as a torch stand.
22. Do not lay an operating torch to rest on a gas cylinder. If there is a gas leak in the cylinder area, there could be a fire.

Coal Tar/Asphalt Applications

1. Do not smoke or eat while performing tar-roofing work.
2. Stand clear of hot asphalt when it is being dumped out of the kettle.
3. Do not stand, work, or operate equipment such as felt laying machines or mechanical moppers within three feet of any unprotected roof opening or within five feet of any unprotected roof edge.

Single-Ply Roofing

- Wear respirators when hot air welding PVC or when performing adhesive welding procedures.

Conveyors

1. Do not climb on conveyor equipment.
2. Do not ride on any conveyors.
3. When using a belt driven conveyor to load a trailer bed, the person inside the trailer shall give verbal commands to the person loading the conveyor.

JOB-SPECIFIC RULES

Roof Felt Slitter

1. Replace the guards before starting the machine, after making adjustments and after making repairs to a machine.
2. Do not remove, alter, or bypass any safety guard or device when operating the machine.
3. Read and obey safety warnings posted on the machine.
4. Do not wear loose clothing, jewelry, or neckties when operating machine.
5. Long hair must be contained under a hat or hair net, regardless of gender.
6. Do not try to stop a work piece as it goes through any machine. If the machine becomes jammed, disconnect the power before clearing the jam.
7. Report any missing machine or tool guard immediately to your supervisor.

Vehicle Loading

1. Plan the move before loading; ensure that you have an unobstructed pathway and that the vehicle is parked as close to the equipment or material as possible.
2. Keep bumpers/tailgates free of grease, water, etc.; remove buildup of material such as dirt, mud, etc.
3. Use lifting aids such as dollies, pallet jack, and forklift or get assistance from a co-worker to place dock plate resting between loading dock and truck surface.
4. If equipment or material that is to be loaded into truck is too heavy or bulky, use lifting aids such as hand trucks, dollies, pallet jacks and carts, or get assistance from co-workers.
5. Secure all equipment and material within the truck to eliminate or reduce movement.

Crane Truck or Boom Conveyor Truck

1. Only trained and employer authorized personnel are permitted to operate the crane truck or boom conveyor.
2. Park on firm level surface, place the vehicle in neutral, and apply the emergency brake.
3. If the truck is equipped with an audible back up warning device, engage the alarm before backing into a location.
4. If the truck is equipped with mechanical, hydraulic, or pneumatic jacks, braces or stabilizers engage such, prior to engaging the swing conveyor.
5. Do not engage the swing conveyor if there are overhead obstructions in the way. Allow sufficient distance for wind gust that would cause the conveyor to contact power lines.
6. Never climb the conveyor to gain access to the roof, use a ladder.
7. Do not load supplies onto a roof if there are unguarded openings such as skylights.

KETTLEMEN

General

1. Do not leave kettles or tankers unattended while they are being fired.
2. Take breaks in shaded areas.
3. Do not smoke or eat while performing asphalt work.
4. Stand clear of hot asphalt when it is being dumped out of the kettle.
5. Do not place a pumper or agitator into kettles or tankers.

Personal Protective Equipment

1. Wear face shields when loading and withdrawing hot liquid asphalt from a kettle or tanker.
2. Wear your personal protective equipment such as goggles, gloves, and respiratory protection when operating the kettle.
3. Do not wear contact lenses when operating the kettle.

Job Site Safety

1. Do not walk under partially demolished walls or floors.
2. Stop working outdoors and seek shelter during lightning storms.
3. Do not begin working until barricades, warning signs or other protective devices have been installed to isolate the work area.
4. Do not throw or toss roofing scraps such as shingles, rubber roofing material, or any other debris outside barricaded areas.

5. Walk around or step over holes, rocks, and roots in your pathway.
6. Stay clear of all trucks, forklifts, cranes, and other heavy equipment when in operation.
7. Do not approach any heavy equipment until the operator has seen you and has signaled to you that it is safe to approach.
8. Walk around or duck under protruding branches and limbs.
9. Do not walk on fallen trees; walk on the ground.
10. Do not clear brush by hand within 100 ft. of heavy equipment operations.
11. Keep combustible liquids stored and covered in approved containers.

SHOP/SERVICE EMPLOYEES

Lockout/Tag out

NOTE: Devices such as padlocks shall be provided for locking out the source of power at the main disconnect switch. Before any maintenance, inspection, cleaning, adjusting or servicing of equipment (hydraulic, electrical, mechanical or air) that requires entrance into or close contact with the machinery or equipment, the main power disconnect switch or valve, or both, controlling its source of power or flow of material, shall be locked-out or blocked off with a padlock, blank flange or similar device.

1. Do not perform any maintenance, inspection, cleaning, adjusting or servicing of any equipment without following the employer lockout / tag out program.
2. If required to work on powered equipment (hydraulic, electrical, air, etc.), you must have your personal padlock with your name on it and personal key on your person at all times.
3. Attach your own lock or tag when you need to isolate an energy source.
4. Do not remove a lock from any equipment unless you placed it there yourself. Each person shall place his/her own lock/tag when required to isolate an energy source.
5. Do not start any adjustment, service or repair without verifying that the tag/lock out switch or control cannot be by-passed or over-ridden.
6. Disconnect and padlock all machine power disconnects in the off position before removing guards for the purpose of working "ON" or "IN" the machinery or its approaching un guarded parts. (NOTE: When more than one employee is working on a single piece of equipment, each employee must use his own padlock along with lockout tongs to lock out the equipment. When the work is completed, he must remove only his lock.)
7. Lockout verification:
 - Verify that the locked-out switch or control cannot be overridden.
 - Test the equipment to be certain that the locked-out switch is de-energized and not simply malfunctioning.
 - Press all start buttons to see if the equipment starts.
 - Ensure the system you will be working on is the same one that has been locked out.
8. Before restarting the equipment, verify the following:
 - All tools and other items have been removed.
 - All machine guards are in place.
 - All electric systems are reconnected.
 - All employees are clear of equipment.
9. Before machinery is put back into use after LOCKOUT/TAG OUT, give a verbal announcement / sound warning to fellow employees.

Electrical Powered Tools

1. Do not use power equipment or tools on which you have not been trained.
2. Keep power cords away from the path of drills, saws, vacuum cleaners, floor polishers, mowers, slicers, knives, grinders, irons, and presses.
3. Do not carry plugged-in equipment or tools with your finger on the switch.
4. Do not carry equipment or tools by the cord.
5. Disconnect the tool from the outlet by pulling on the plug, not the cord.
6. Turn the tool off before plugging or unplugging it.

7. Do not leave tools that are "On" unattended.
8. Do not handle or operate electrical tools when your hands are wet or when you are standing on wet floors.
9. Do not operate spark inducing tools such as grinders, drills, or saws near containers labeled "Flammable" or in an explosive atmosphere such as a paint spray booth.
10. Turn off electrical tools and disconnect the power source from the outlet before attempting repairs or service work. Tag the tool "Out of Service."
11. Do not connect multiple electrical tools into a single outlet.
12. Do not run extension cords through doorways, through holes in ceilings, walls, or floors.
13. Do not drive over, drag, step on or place objects on a cord.
14. Do not operate a power hand tool or portable appliance with a two-pronged adapter or a two-conductor extension cord.
15. Do not use a power hand tool while wearing wet cotton gloves or wet leather gloves.
16. Never operate electrical equipment barefooted. Wear rubber-soled or insulated work boots.
17. Do not operate a power hand tool or portable appliance while holding a part of the metal casing or holding the extension cord in your hand. Hold all portable power tools by the plastic handgrips or other nonconductive areas designed for gripping purposes.
18. Do not operate a power hand tool or portable appliance that has a frayed, worn, cut, improperly spliced, or damaged power cord.
19. Do not operate a power hand tool or portable appliance if the ground pin from the three-pronged power plug is missing or has been removed.

Power Saws

1. Wear safety goggles, protective gloves, a dust mask, and hearing protection when operating a power saw.
2. Do not wear loose clothing or jewelry.
3. Clean any residue from the blade or cutting head before making a new cut with the power saw.
4. Do not use a power saw that has cracked, broken, or loose guards or other visible damage.
5. Keep your hands away from the exposed blade.
6. Operate the saw at full cutting speed, with a sharp blade, to prevent kickbacks.
7. Do not alter the anti-kickback device or blade guard.
8. Do not perform cutting operations with the power saw while standing on a wet or slippery floor.
9. When using the power saw, do not reach across the cutting operation.
10. Cut away from your body and below your shoulder level when you are using a power saw.
11. If the saw becomes jammed, turn the power switch of the saw to "Off" before pulling out the incomplete cut.

Pneumatic Tools

1. Do not point a compressed air hose at bystanders or use it to clean your clothing.
2. Do not use tools that have handles with burrs or cracks.
3. Do not use compressors if their belt guards are missing. Replace belt guards before use.
4. Turn the tool "off" and let it come to a complete stop before leaving it unattended.
5. Disconnect the tool from the airline before making any adjustments or repairs to the tool.
6. Engage positive locks on hoses and attachments before use.
7. Shut off pressure valve and disconnect airline when not in use.
8. Tag damaged or defective pneumatic tools "Out of Service" to prevent usage of the tool by other employees.

Powder Actuated Tools

1. Only employer-authorized personnel, with a valid certification card may operate powder-actuated tools.
2. Wear safety glasses, goggles, or face shields when operating powder actuated tools.
3. Wear earplugs or earmuffs when making fastenings.
4. Do not permit bystanders in the area when using a powder-actuated tool.
5. Do not load tool until ready to make a fastening.
6. Keep tool pointed in a safe direction (away from personnel).
7. Post a sign alerting co-workers that a powder actuated tool is being used.

8. After use, lock powder actuated tools and powder loads in a container and store in a safe place such as a locker or the trunk of a car.

Personal Protective Equipment

1. Wear earplugs or earmuffs in areas posted "Hearing Protection Required."
2. Wear safety glasses or face shields in areas posted "Eyewear Protection Required."
3. Wear safety glasses, goggles, or face shield when using chippers, grinders, lathes, sanders, or when working with concrete.
3. Do not continue to work if your safety glasses become fogged. Stop work and clean the glasses until the lenses are clear and defogged.
4. Wear hard hats or approved head protection in areas posted "Hard Hat Protection Required."
5. Do not paint or drill holes in hard hats.
6. Do not wear hard hats that are dented or cracked.
7. Wear rubber gloves when handling finishing chemicals such as acids.
8. Wear long pants when working with concrete.
9. During mixing of concrete compound and water, wear your dust mask or respirator mask provided.

Carpet Laying

1. Carry knives in a leather pouch.
2. Keep sealing iron in the sealing iron tray when iron is energized.
3. When using power stretchers on long pulls, make sure the power head handle is locked down. Do not sit on handle or attempt to hold the handle down with your hand.
4. Do not leave knives and tools lying on the floor.
5. Wear kneepads.

Resilient Floor Coverings

1. Before you begin installation of the floor coverings, ventilate the area by opening windows, doors, or by using an exhaust fan.
2. Read labels and safety recommendations on all materials used in installation, i.e. adhesives, solvents, seam sealers, polishers, patching compounds, and cleaners.
3. Never leave propane torches that are being used for heating unattended.
4. Keep all flammable materials away from flame or spark.
5. Flush your skin or eyes with water if they are exposed to hazardous material.
6. Use heat resistant gloves when using heating tools.
7. Wear kneepads.
8. Keep the work area well lighted and uncluttered.

NOTE: When work involves the removal of a resilient floor covering structure that contains or is assumed to contain asbestos, always check with supervisor before proceeding.

Sanding Equipment

1. Always leave the floor sanding machine(s) unplugged until ready for use.
2. Unplug the belt sander when changing the sander belt.
3. Always use approved dust mask when sanding.

Stairways, Floors, and Openings

1. Do not work on open-sided floors, elevated walkways, or elevated platforms if there are no guardrails in place.
2. Stand clear of floor openings if guardrails or covers are removed or displaced.

ALL EXCAVATIONS

1. The contractor communicates with the local One-Call Service Center **AND** utility owners who are not members of the one-call center. This communication must take place 48 hours to 72 hours, but not more than 10 days (or per state regulations) prior to the start of the excavation.
2. The route of the excavation will be white lined (with white spray paint), flagged, staked, or a combination of these to mark the dig site before the locator arrives on the job.
3. The contractor hand digs within 18 inches or 24 inches (depending on state regulations) horizontally on either side of the marked facility.
4. The contractor requests new locates to again identify the underground facilities on all excavations incurring extended time requirements of 10 days or more and following inclement weather.
5. Photographs or videos are taken after the utility has been marked before the excavation begins.

CRITICAL/HIGH PRIORITY EXCAVATIONS

On numerous occasions contractors will be required to excavate on or near critical or high priority underground facilities. These utilities, if hit during the excavation, can result in death, severe injury, or extensive property damage causing major power outages to thousands of consumers. Examples would include high-pressure gas, petroleum lines (catastrophic explosions), and water lines (flooding and ground collapse), power transmission facilities, and fiber optic communication cables (service disruption to 30,000 customers or more for 30 minutes or more). For these reasons, before any excavation begins, the contractor must aggressively discuss this risk with the owner to identify if critical or high priority facilities are located at the excavation site.

If so, in addition to the 5 best practices defined above, the following 3 best practices also apply:

6. The contractor must request a pre-excavation meeting on site with the facility owner and prime contractor (if any).
7. The contractor potholes (hand digging, use of air knives or vacuum excavation techniques) to verify utility locates or mark-outs.
8. The contractor maps the coordinates of the locates in relation to a stationary object(s), such as a tree, fence, building, etc.

DOCUMENTATION REGARDING COMPLIANCE WITH BEST PRACTICES

Documentation will take many forms, but it must include certain information, signed and dated by the construction owner or senior manager. Ref. appendix 10.1.

Preplanning of excavation project

- Notify local One-Call Service Center: Federal O.S.H.A. rules and legislation in most states require contractors who plan to excavate to notify the local One Call Center and non-member facility owners 48 to 72 hours before the job begins. Additionally, there should be no excavating of any kind, mechanical or by hand, without first obtaining locates. If private lines exist, they too must be properly located. Property managers or owners of private facility systems can assist prior to calling for locates.
- The excavator must have a thorough knowledge of the jurisdictional regulations in which the dig site is located and planned for accordingly. For example, in some metropolitan areas it is unlawful for contractors to touch water valves or other utility control devices.
- To enhance the quality of the job-preplanning phase, the company must determine if the excavation involves critical or high priority facilities. The contractor should specifically ask the owner to identify these in their bid specifications, or at least discuss with the owner and document it. These accidents would be any dig up that could result in severe injury, death, or extensive property damage causing major power outages to thousands of customers. Some examples: high-pressure gas, petroleum (catastrophic explosion), water lines (flooding and ground collapse), power transmission facilities, and fiber optic communication cables producing an FCC reportable incident (service disruption to 30,000 or more customers for 30 minutes or more).

Identify Facilities - Large Projects

- Be sure to maintain documentation of the locate request number and a sketch of the locates. This documentation should be available at the site of excavation.
- Make sure the request numbers are valid and that they are issued in your company's name.

- The proposed dig area should be pre-marked with white paint prior to notifying the One Call Center for locates.
- Request a pre-construction meeting with facility owners and locators to review the excavation area. This is very important if the job involves a critical or high priority facility or the job is in a congested metropolitan area. The owner should be questioned concerning the need for Subsurface Utility Engineering.
- Make sure that all members and non-member facility owners of the one-call center have been contacted for locates.
- Photograph or videotape of dig area in relation to the locates in case of problems later on. An alternative would be to map the coordinates of the locates in relation to a stationary object(s) such as a tree, fence, building, etc.

Identify Facilities - Small Projects

- The proposed dig area should be pre-marked with white paint prior to notifying One Call for locates.
- Make sure that all utility owners (one-call members and non-member owners) have been contacted for locates.
- Be sure to maintain documentation of the locate request number and a sketch of the locates if supplied by the facility owner. This documentation should be available at the site of excavation.
- Make sure request numbers are valid and that they are issued in your company's name.
- If there is a critical or high priority facility line in dig area, make arrangements for the locator and the facility owner to be on the job site with you during the excavation. If the locator and/or facility owner refuses to be present, then document this response by appending it to the ticket request.

On the job site

- Once on the job site, begin job preparation by reviewing list of multiple non-members of your One-Call Service Center that are in your dig area and make sure that locate marks for all facilities are present. Consult your color chart if necessary to ensure all facilities have been located. If any underground system is not marked, contact your supervisor, call the owner immediately, and then document responses.
- Account for all feeds to houses or buildings before you excavate. You should be able to see them in the air or marked on the ground.
- Identify and/or have located all private facilities that have not already been located. This includes propane and private lines, sprinklers, etc. Look for sewer vents on the roof of the house, look for sprinkler heads and turn on the system if necessary. Look for physical evidence that facilities have not been located.
- Sketch the location and document the depth of all public and private facilities on your work order for future reference.
- If there is not a sketch of all other facilities, draw a sketch of locates with measurements to fixed objects for future reference.
- Expose all facilities that you will be crossing. All critical or high priority facilities should be exposed by pot holing or use of locating equipment every 100 feet if parallel within 5 feet of dig area.
- If there are no locates, if marks are incomplete, or if exposing indicates locates are not accurate, *DO NOT DIG*. Contact the facility owner to complete the locates.
- Request new locates if the job extends beyond 10 days and following inclement weather.
- Once you have verified the location of all lines and you have completed the Job Check List, you can begin to excavate. Remember to complete the sketch of your dig site before you start excavating.
- Photograph or video tape the dig site in relation to the locates before the excavation begins so that valid documentation can be presented in case of problems later on.

Excavating

- You should hand dig within 24 inches (or as your state requires) of any line, pedestal, closure, riser guard, pole (with riser), meter or other structure.
- If you must use mechanical equipment within 24 inches of a mark you should expose the line first.
- If you are paralleling a critical or high priority line, or working on one, you should pot hole every 100 feet, or as appropriate, to verify the location and depth of the line. If the locate is not accurate, the facility owner should be contacted immediately.
- If you are using a boring machine, you should try to bore away from all facilities. If you must cross a facility, expose the line to verify location and depth and change the bore route and/or depth to avoid the facility. Contact your supervisor

- to approve route changes.
- Do not place excavated dirt or street plates on top of locate marks. Every attempt should be made to keep marks visible and fresh at all times. When excavated spoil must be placed on locate marks, ensure that a detailed sketch of the marks has been made and pictures taken to support the sketch.

Backfilling

- All lines exposed during excavation must be supported to prevent damage, stretching, kinking, etc.
- Before backfilling, extra caution must be taken to remove large rocks, sharp objects, and large chunks of hard packed clay or dirt.
- No trash or pieces of abandoned lines should be backfilled into the trench.

What to do if damage does occur:

Immediately contact the Police and Fire Department emergency services in case evacuation is required. In addition:

- All damages, including kinking or sheath damage must be reported immediately to a supervisor and to the facility owner or operator.
- Pictures will be taken and reports completed to help document the damage and assist in resolving any claim that may be filed.
- If a water line is damaged, you should attempt to stop the flow of water if allowed to do so within jurisdictional regulations at the site.
- If a gas or power line is damaged, it may be necessary to leave the area immediately and notify other workers in the area and facility owners. *REMEMBER, SAFETY FIRST!!! FOLLOW COMPANY SAFETY STANDARDS AND PROCEDURES.*
- Complete Damage Investigation Report (example attached) and submit to your supervisor.

Employee Accountability

Be advised that failure to perform any of the following procedures may result in disciplinary action.

- Digging without obtaining locates.
- Smoking is not permitted in, or around, the excavation in case of gas leaks.
- Excavating, including hand digging, without locates for any or all facilities including private lines.
- Report any facility damage regardless of severity.
- Failure to check paperwork or equipment before leaving the shop.
- Failure to utilize the job checklist provided.

Obtain and learn the laws and regulations that pertain to excavating in your state.

Everyone will incorporate these procedures into their daily routine. By utilizing these procedures, it will increase your productivity and efficiency, not to mention the obvious safety benefits.

JOB SITE PERSONNEL

1. Do not start work until barricades, barrier logs, fill or other protection have been installed to isolate the work area from local traffic.
2. Reflective warning vests must be worn by traffic flagmen who are assigned to controlling traffic.
3. Do not walk under platforms that bridge a trench.
4. Do not enter a trench unless you have been given permission by the competent person. Seek out and identify the designated "Competent person" for the excavation site.

Access and Egress Safety

1. Use ladders, structural ramps, or stairways as a means of access or egress from excavations.
2. Do not use scrap lumber, excavation machinery, or other improvised devices for climbing.
3. Do not climb a ladder unless it extends at least three (3) feet or three (3) rungs beyond the edge of the trench.

Trench box Safety

1. Do not enter a trench box during its installation or removal.
2. Do not enter a trench box that is being moved.

Hot Line Safety

1. Clean all protective line equipment after each use, prior to storage.
2. Wear rubber gloves or use hot sticks when removing tree branches, limbs, or similar objects from contact with high voltage lines, panels, or equipment.
3. Do not wear rubber protective gloves while climbing or descending a pole.
4. Wear 100% cotton or flame resistant shirts or jumpers (with sleeves rolled down) and protective hats when working on or near live parts, lines, and panels or when climbing poles.
5. Wear body belts with straps or lanyards when working at an elevated position (poles, towers, etc.).
6. Visually inspect body belts and straps before use for defects, wear, and damage.
7. When working with lines of 600 volts or more:
 - Wear rubber gloves or use hot sticks when placing protective equipment on/around energized voltage conductors.
 - Do not work on the line that is removed from service until the line is cleared, tagged, tested, and grounded.
 - Treat bare wire communication conductors on structures as energized lines unless they are protected by insulated conductors.
8. Treat bare wire communication conductors on power poles and structures as energized lines (with voltages in excess of 600 volts) unless the conductors are protected by insulating materials.
9. Do not remove any ground until all employees are clear of the temporary grounded lines or equipment.
10. After a capacitor has been disconnected from its source of supply, wait five minutes before short-circuiting and grounding it.
11. Do not contact the terminals, jumpers, or line wires connected directly to capacitors until the capacitors have been short-circuited and/or grounded.
12. Visually inspect and wipe down all hot line tools each day before use.
13. Do not wear rubber gloves with protectors while using hot line tools.
14. Do not use defective hot line tools. Mark them as defective and turn them in for repair or replacement.

Stringing/Removing Deenergized Conductors

1. Keep conductors that are being strung in or removed under positive control to prevent accidental contact with energized circuits.
2. Do not exceed the load rating for stringing lines, pulling lines, sock connections or load-bearing hardware and accessories.
3. Do not use defective pulling lines or defective accessories. Mark the defective items and turn them in for repair or replacement.
4. Do not use conductor grips on wire ropes unless the grips are designed for that particular purpose.
5. If an existing line that crosses over a conductor is to be deenergized, ground the line on both sides of the crossing or treat the conductor being crossed as energized.

TRENCHING AND SHORING PROCEDURES

A. SCOPE & APPLICATION

The company policy sets forth the official practices required for excavations made by employees. All employees shall be instructed in the health and safety significance of the excavation procedure. Each new employee shall be instructed in the purpose and use of the excavation procedure. The field supervisor in charge of the excavation will make a copy of this procedure available before the start of any work. All personnel not involved in the actual trenching procedures will be given basic awareness information on all operations.

B. GENERAL REQUIREMENTS

All excavations shall be made in accordance with the rules, regulations, requirements, and guidelines set forth in 29 CFR 1926.650, .651, and .652; the Occupational Safety and Health Administration's standard on Excavations, except where otherwise noted below.

C. INSPECTION/

1. Procedures

A competent person shall be placed in charge of all excavations.

Underground utilities must be located and marked before excavation begins.

Employees are not allowed in the excavation while heavy equipment is digging.

All open holes or trenches must be protected.

2. Inspections

The competent person shall conduct inspections:

- * Daily and before the start of each shift.
- * As dictated by the work being done in the trench.
- * After every rain storm.
- * After other events that could increase hazards, such as snowstorm, windstorm, thaw, earthquake, dramatic change in weather, etc.
- * When fissures, tension cracks, sloughing, undercutting, water seepage, bulging at the bottom, or other similar conditions occur.
- * When there is a change in the size, location, or placement of the spoil pile.
- * When there is any indication of change or movement in adjacent structures.

(For excavations 4 feet or greater in depth, a trench inspection form shall be filled out for each inspection.)

D. SOIL TYPES

Type A -Most stable: clay, silty clay, and hardpan (resists penetration). No soil is Type A if it is fissured, is subject to vibration of any type, has previously been disturbed, or has seeping water.

Type B - Medium stability: silt, sandy loam, medium clay and unstable dry rock; previously disturbed soils unless otherwise classified as Type C; soils that meet the requirements of Type A soil but are fissured or subject to vibration.

Type C - Least stable: gravel, loamy sand, soft clay, submerged soil or dense, heavy unstable rock, and soil from which water is freely seeping.

[Layered geological strata](#) - The soil must be classified on the basis of the soil classification of the weakest soil layer. Each layer may be classified individually if a more stable layer lies below a less stable layer, i.e. where a Type C soil rests on top of stable rock.

Because most excavations will be conducted in order to repair / replace existing pipelines or equipment (i.e. the soil has been previously disturbed), excavations shall be made to meet the requirements for Type B or Type C soils only, as appropriate.

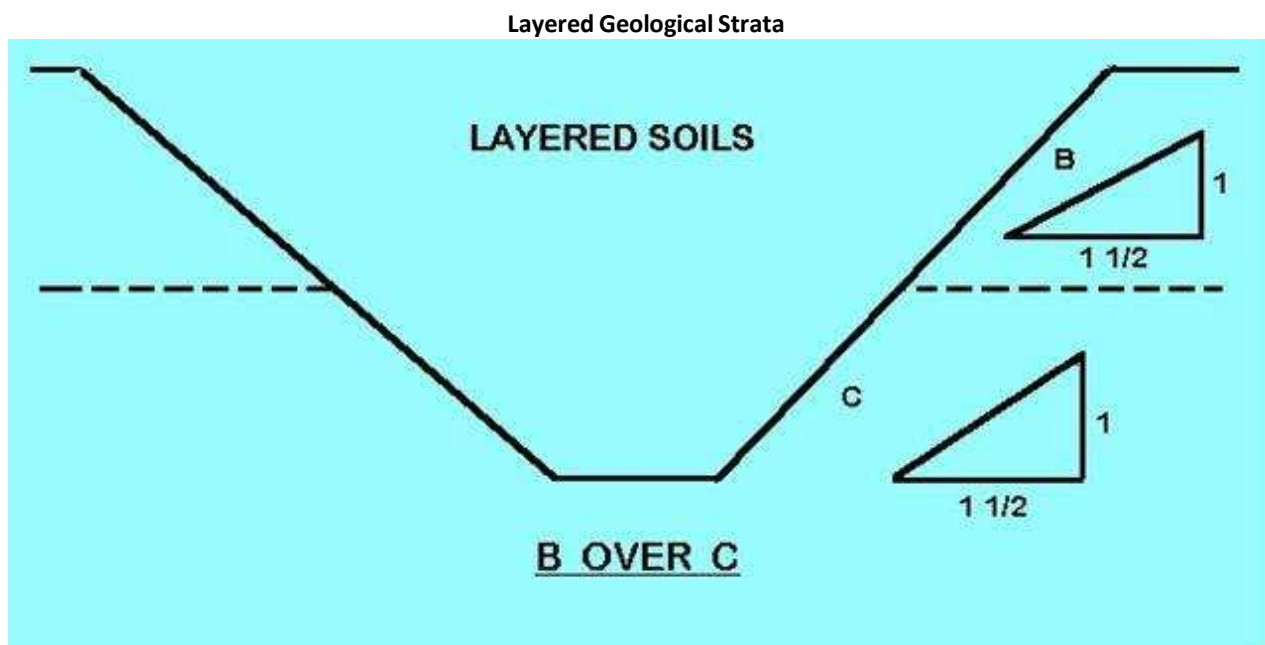

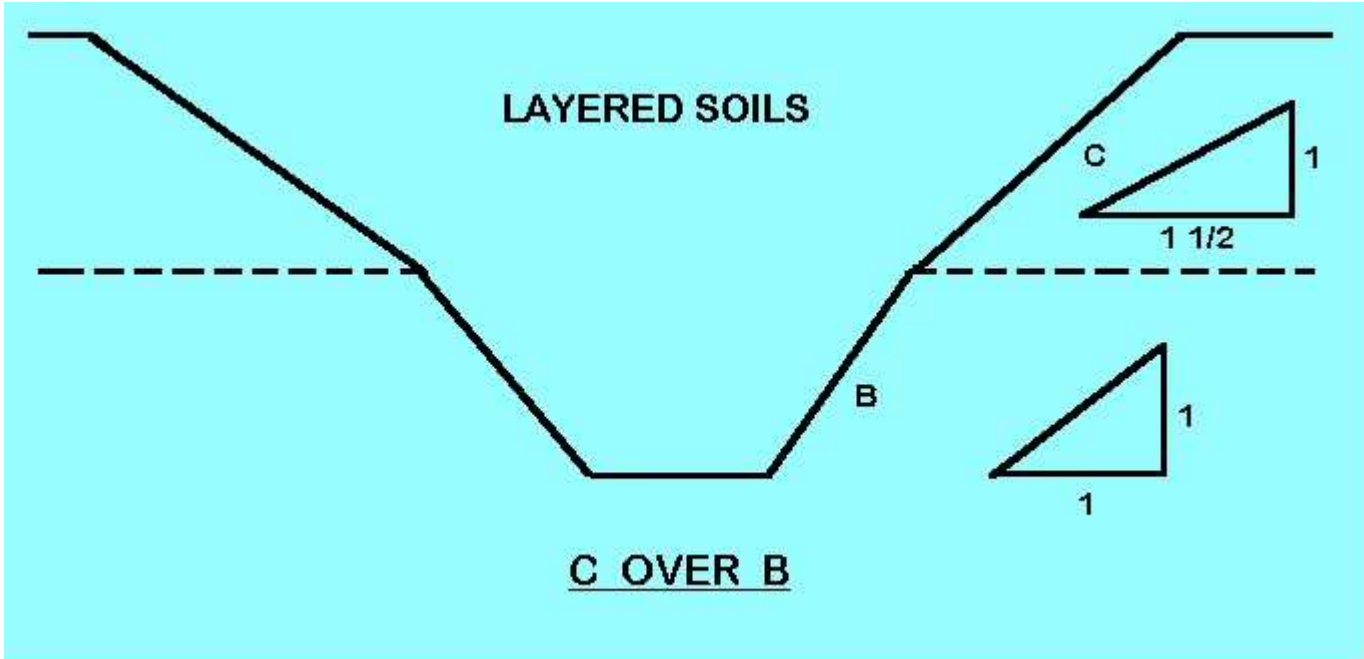

E. TESTING METHODS

The [competent person](#) in charge of the excavation shall be responsible for determining whether the soil is Type B or C. If the competent person wants to classify the soil as Type C, they do not need to do any tests. However, tests must be conducted to determine if the soil can be classified as Type B. To do this, the competent person shall use a visual test coupled with one or more manual tests.

1. Visual test

In addition to checking the items on the trench inspection form, the [competent person](#) should perform a visual test to evaluate the conditions around the site. In a visual test, the entire excavation site is observed, including the soil adjacent to the site and the soil being excavated. The competent person also checks for any signs of vibration.

During the visual test, the competent person should check for crack-line openings along the failure zone that would indicate tension cracks, look for existing utilities that indicate that the soil has been previously disturbed, and, if so, what sort of backfill was used, and observe the open side of the excavation for indications of layered geologic structuring.

This person should also look for signs of bulging, boiling, or sloughing, as well as for signs of surface water seeping from the sides of the excavation or from the water table.

In addition, the area adjacent to the excavation should be checked for signs of foundations or other intrusions into the failure zone, and the evaluator should check for surcharging and the spoil distance from the edge of the excavation.

F. SPOIL

1. Temporary spoil shall be placed no closer than 2 feet from the surface edge of the excavation, measured from the nearest base of the spoil to the cut. This distance should not be measured from the crown of the spoil deposit. This distance requirement ensures that loose rock or soil from the temporary spoil will not fall

on employees in the trench.

Spoil should be placed so that it channels rainwater and other run-off water away from the excavation. Spoil should be placed so that it cannot accidentally run, slide, or fall back into the excavation.

2. Permanent spoil should be placed some distance from the excavation.

G. SURFACE CROSSING OF TRENCHES

Surface crossing of trenches should not be made unless absolutely necessary. However, if necessary, they are only permitted under the following conditions:

- * Vehicle crossings must be designed by and installed under the supervision of a registered professional engineer.
- * Walkways or bridges must:
 - * have a minimum clear width of 20 inches,
 - * be fitted with standard rails, and
 - * extend a minimum of 24 inches past the surface edge of the trench.

H. INGRESS AND EGRESS

Trenches 4 feet or more in depth shall be provided with a fixed means of egress.

Spacing between ladders or other means of egress must be such that a worker will not have to travel more than 25 feet laterally to the nearest means of egress.

Ladders must be secured and extend a minimum of 36 inches above the landing.

Metal ladders should not be used when electric utilities are present.

I. EXPOSURE TO VEHICLES

Employees exposed to vehicular traffic shall be provided with and required to wear reflective vests or other suitable garments marked with or made of reflectorized or high-visibility materials.

Trained flag persons, signs, signals, and barricades shall be used when necessary.

J. EXPOSURE TO FALLING LOADS

All employees on an excavation site must wear hard hats.

Employees are not allowed to work under raised loads.

Employees are not allowed to work under loads being lifted or moved by heavy equipment used for digging or lifting.

Employees are required to stand away from equipment that is being loaded or unloaded to avoid being struck by falling materials or spillage.

Equipment operators or truck drivers may remain in their equipment during loading and unloading if the equipment is properly equipped with a cab shield or adequate canopy.

K. WARNING SYSTEMS FOR MOBILE EQUIPMENT

The following steps should be taken to prevent vehicles from accidentally falling into the trench:

- * Barricades must be installed where necessary,
- * Hand or mechanical signals must be used as required,
- * Trenches left open overnight shall be fenced and barricaded.

L. HAZARDOUS ATMOSPHERES AND CONFINED SPACES

Employees shall not be permitted to work in hazardous and/or toxic atmospheres. Such atmospheres include those with:

- * less than 19.5% oxygen,
- * a combustible gas concentration greater than 20% of the lower flammable limit, and,
- * Concentrations of hazardous substance that exceed those specified in the Threshold Limit Values for airborne contaminants established by the ACGIH.

All operations involving such atmospheres must be conducted in accordance with OSHA requirements for occupational health and environmental controls for personal protective equipment and for lifesaving equipment. Engineering controls (such as ventilation) and respiratory equipment may be required.

M. TESTING FOR ATMOSPHERIC CONTAMINANTS

If there is any possibility that the trench or excavation could contain a hazardous atmosphere, atmospheric testing must be conducted prior to entry. Conditions that might warrant atmospheric testing would be if the excavation was made in a landfill area or if the excavation was crossed by, was adjacent to, or contained pipelines containing a hazardous material (for example, natural gas lines).

Testing should be conducted before employees enter the trench and should be done regularly to ensure that the trench remains safe. The frequency of testing should be increased if equipment is operating in the trench.

Testing frequency should also be increased if welding, cutting, or burning is done in the trench.

Employees required to wear respiratory protection must be trained, fit-tested, and enrolled in a respiratory protection program.

Some trenches qualify as confined spaces. When this occurs, compliance with OSHA' Confined Space is also required.

N. STANDING WATER AND WATER ACCUMULATION

Methods for controlling standing water and water accumulation must be provided and should consist of the following if employees must work in the excavation:

- * Use of special support or shield systems approved by a registered professional engineer.
- * Water removal equipment, such as pumps, used and monitored by a competent person.
- * Employees removed from the trench during rainstorms
- * Trenches carefully inspected by a competent person after each rain and before employees are permitted to re-enter the trench.

O. BENCHING, SLOPING, SHORING, AND SHIELDING REQUIREMENTS

All excavations or trenches 4 feet or greater in depth shall be appropriately benched, shored, or sloped according to the procedures and requirements set forth in OSHA's Excavation standard, 29 CFR 1926.650, .651, and .652.

Excavations or trenches 20 feet deep or greater must have a protective system designed by a registered professional engineer.

Excavations under the base of footing of a foundation or wall requires a support system designed by a registered professional

engineer.

Sidewalks and pavement shall not be undermined unless a support system or another method of protection is provided to protect employees from their possible collapse.

P. BENCHING

There are two basic types of benching, [single and multiple](#), which can be used in conjunction with sloping.

All benched excavations 20 feet or less in depth shall have a maximum allowable slope of 1:1.

Basic Types of Benching

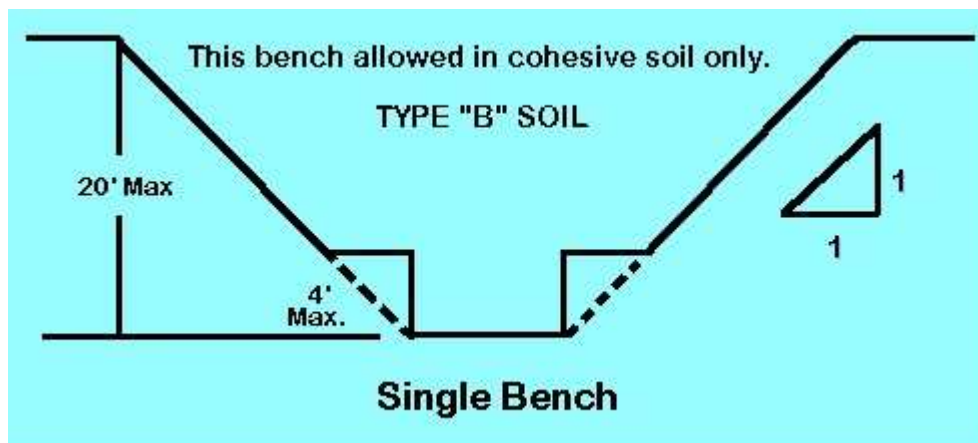
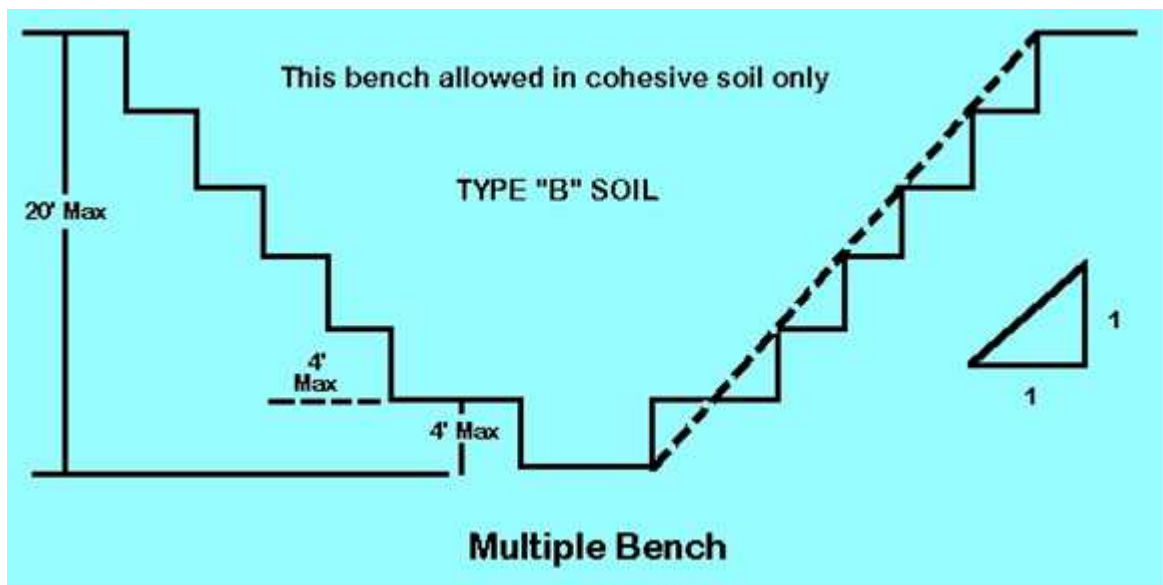

In **Type B** soil, the vertical height of the benches must not exceed 4 feet. Benches must be below the maximum allowable slope for that soil type. In other words, a 10-foot deep trench in Type B soil must be benched back 10 feet in each direction, with the maximum of a 45-degree angle.

Benching is not allowed in Type C soil.

Q. SLOPING

Maximum allowable slopes for excavations less than 20' based on soil type and angle to the horizontal are as follows:

<u>Soil Type</u>	Height/depth ratio	Slope angle
Type B	1:1	45 degrees
Type C	1 1/2:1	34 degrees

A 10-foot-deep trench in Type B soil would have to be sloped to a 45-degree angle, or sloped 10 feet back in both directions. Total distance across a 10-foot-deep trench would be 20 feet, plus the width of the bottom of the trench itself. In Type C soil, the trench would be sloped at a 34-degree angle, or 15 feet back in both directions for at least 30 feet across, plus the width of the bottom of the trench itself.

Illustration of Simple Slope Trenching in B and C Type Soils

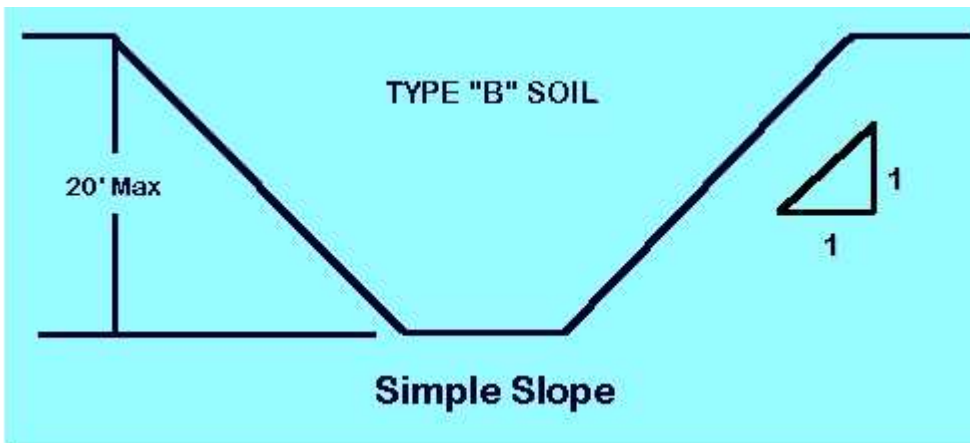

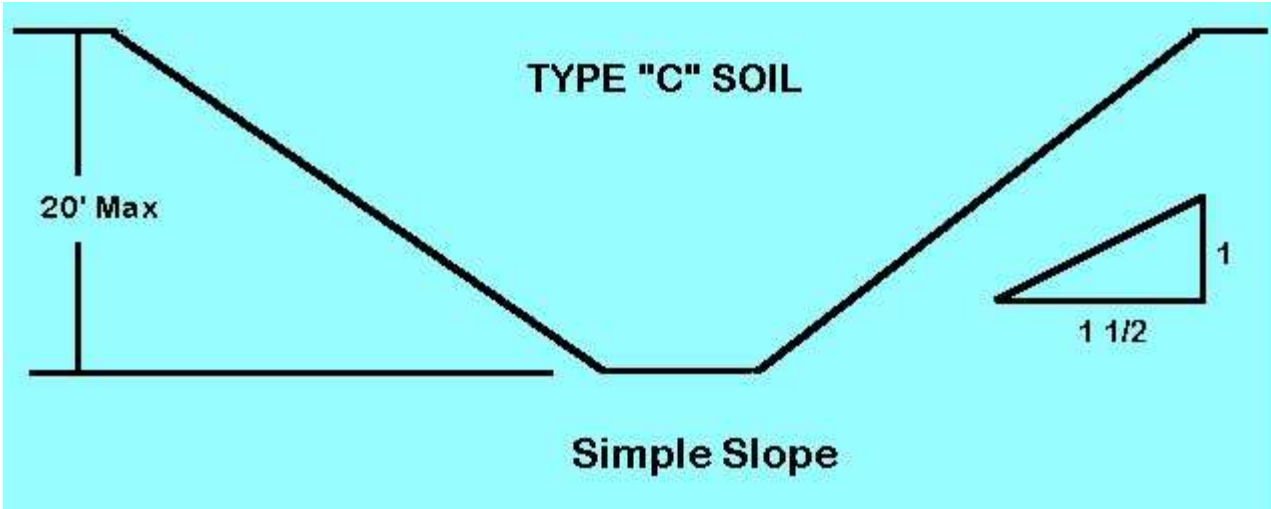
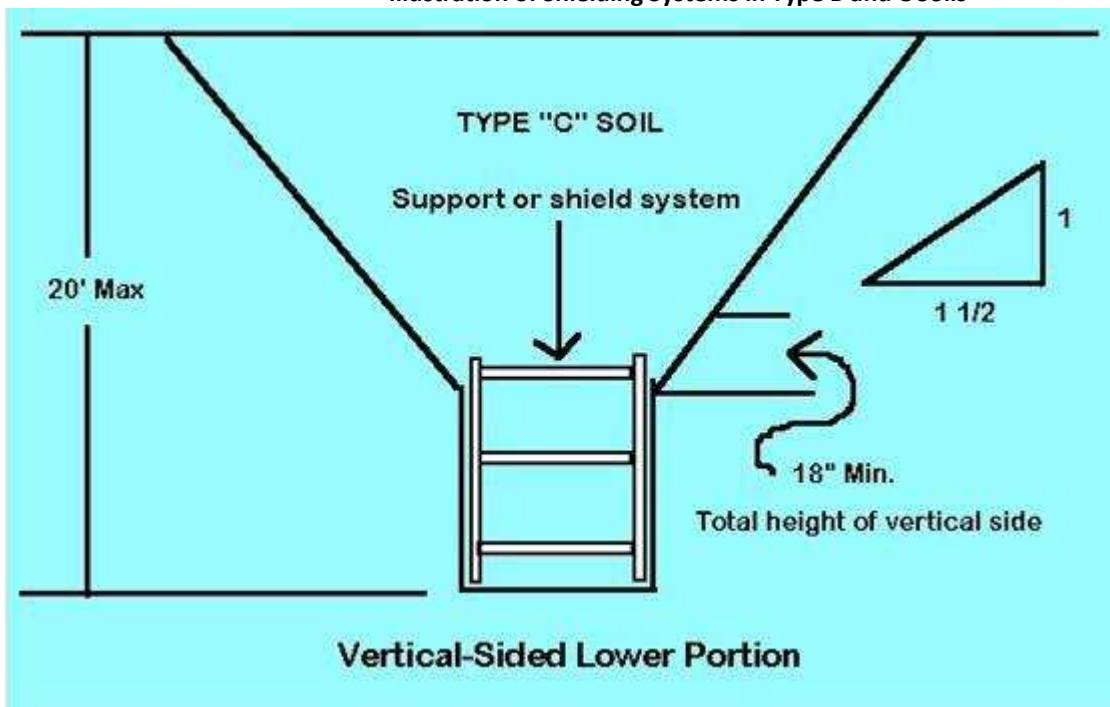
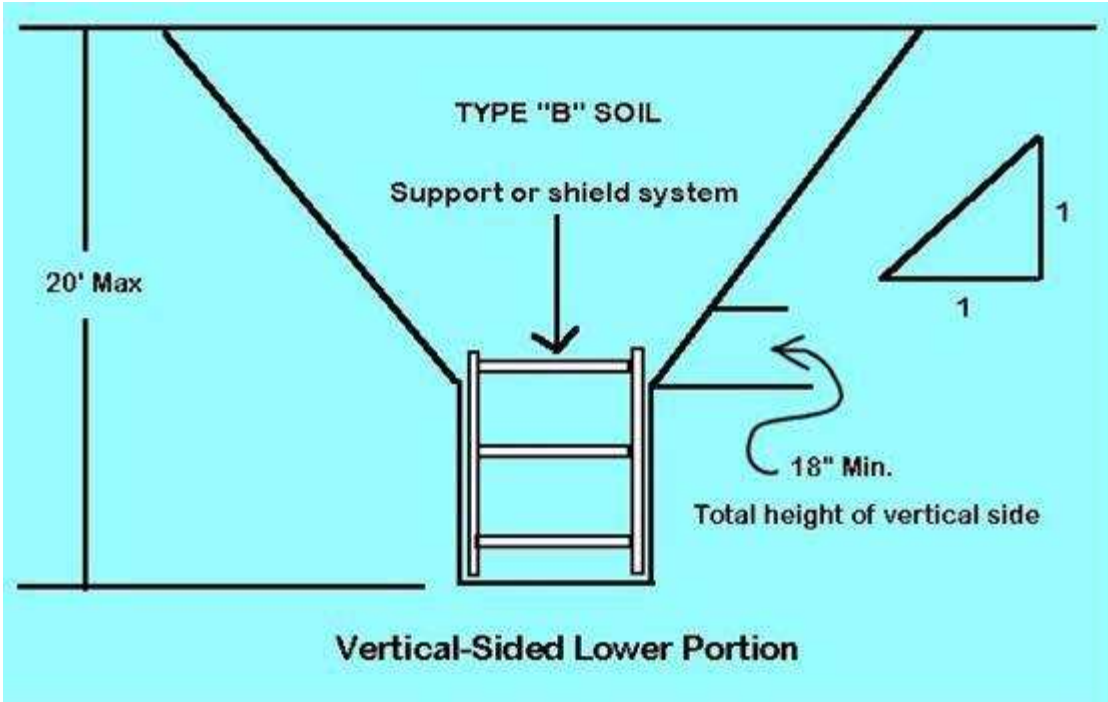

Illustration of Shielding Systems in Type B and C Soils





R. SHORING

Shoring or shielding is used when the location or depth of the cut makes sloping back to the maximum allowable slope impractical. There are two basic types of shoring, timber and [aluminum hydraulic](#).

Because the Physical Plant has aluminum hydraulic shores, they will be the focus of this section. Hydraulic shoring provides a critical safety advantage over timber shoring because workers do not have to enter the trench to install them. They are also light enough to be installed by one worker; they are gauge-regulated to ensure even distribution of pressure along the trench line; and they can be adapted easily to various trench depths and widths. However, if timber shoring is used, it must meet the requirements of 29 CFR 1926.650, .651, and .652.

All shoring shall be installed from the top down and removed from the bottom up. Hydraulic shoring shall be checked at least once per shift for leaking hoses and/or cylinders, broken connections, cracked nipples, bent bases, and any other damaged or defective parts.

The top cylinder of hydraulic shoring shall be no more than 18 inches below the top of the excavation.

The bottom of the cylinder shall be no higher than four feet from the bottom of the excavation. (Two feet of trench wall may be exposed beneath the bottom of the rail or plywood sheeting, if used.)

Three vertical shores, evenly spaced, must be used to form a system.

Wales are installed no more than two feet from the top, no more than four feet from the bottom, and no more than four feet apart, vertically.

S. SHIELDING

Trench boxes are different from shoring because, instead of shoring up or otherwise supporting the trench face, they are intended primarily to protect workers from cave-ins and similar incidents.

The excavated area between the outside of the trench box and the face of the trench should be as small as possible. **The space between the trench box and the excavation side must be backfilled to prevent lateral movement of the box.** Shields may not be subjected to loads exceeding those which the system was designed to withstand.

Trench boxes are generally used in open areas, but they also may be used in combination with sloping and benching.

The box must extend at least 18 inches above the surrounding area if there is sloping toward the excavation. This can be accomplished by providing a benched area adjacent to the box.

Shields may ride two feet above the bottom of an excavation, provided they are calculated to support the full depth of the excavation and there is no caving under or behind the shield.

Workers must enter and leave the shield in a protected manner, such as by a ladder or ramp.

Workers may not remain in the shield while it is being moved.

T. DEFINITIONS

1. Aluminum hydraulic shoring

An engineered shoring system comprised of aluminum hydraulic cylinders (cross braces), used in conjunction with vertical rails (uprights) or horizontal rails (walers). Such a system is designed specifically to support the sidewalls of an excavation and prevent cave-ins.

2. Benching

A method of protecting employees from cave-ins by excavating the sides of an excavation to form one or a series of horizontal levels or steps, usually with vertical or near-vertical surfaces between levels.

3. Cave-in

The separation of a mass of soil or rock material from the side of an excavation, or the loss of soil from under a trench shield or support system, and its sudden movement into the excavation, either by falling or sliding, in sufficient quantity so that it could entrap, bury, or otherwise injure and immobilize a person.

4. Competent person

One who is capable of identifying existing and predictable hazards in the surroundings, or working conditions that are unsanitary, hazardous, or dangerous to employees, and who has authorization to take prompt corrective measures to eliminate them. All competent persons must complete the trenching and shoring class, successfully pass the exam, and be certified for successful completion of the class. A competent person should have and be able to demonstrate the following:

Training, experience, and knowledge of:

- * soil analysis,
- * use of protective systems, and
- * Requirements of 29 CFR 1926 Subpart P.

Ability to detect:

- * conditions that could result in cave-ins,
- * failures in protective systems,
- * hazardous atmospheres, and

* other hazards including those associated with confined spaces.

Authority to take prompt corrective measures to eliminate existing and predictable hazards and to stop work when required.

5. Excavation

Any man-made cut, cavity, trench, or depression in an earth surface, formed by earth removal.

6. Registered professional engineer

A person who is registered as a professional engineer.

7. Shield (shield system)

A structure that is able to withstand the forces imposed on it by a cave-in and thereby protect employees with the structure. Shields can be permanent structure or can be designed to be portable and moved along as work progresses. Also known as trench box or trench shield.

8. Shoring (shoring system)

A structure such as a metal hydraulic, mechanical or timber shoring system that supports the sides of an excavation and which is designed to prevent cave-ins.

9. Sloping (sloping system)

A method of protecting employees from cave-ins by excavating to form sides of an excavation that are inclined away from the excavation so as to prevent cave-ins. The angle of incline varies with differences in such factors as the soil type, environmental conditions of exposure, and application of surcharge loads.

10. Trench (trench excavation)

A narrow excavation (in relation to its length) made below the surface of the ground. In general, the depth is greater than the width, but the width of a trench is not greater than 15 feet. If forms or other structures are installed or constructed in an excavation as to reduce the dimension measured from the forms or structure to the side of the excavation to 15 feet or less, the excavation is also considered to be a trench.

DOCUMENTATION REGARDING COMPLIANCE WITH BEST PRACTICES

ALL EXCAVATIONS

NAME OF CONTRACTOR:	DATE AND TIME OF DAMAGE:
DATE(s) ONE-CALL NOTIFIED	TICKET #
NAME OF NON-MEMBERS NOTIFIED 1. 2. 3.	4. 5. 6. CONTINUE ON REVERSE SIDE.
FACILITY DAMAGED:	SIZE:
LOCATE ACCURATE: YES NO	MEASUREMENT OFF BY: FEET INCHES
ROUTE WHITE LINED: YES NO	HAND DUG: 18" 24"
DIRT ABOVE MARKED FACILITY MECHANICALLY REMOVED: YES NO	NEW LOCATES REQUESTED: YES NO N/A
PHOTOS/VIDEO TAKEN: YES NO	IF YES, SUBMIT COPIES

**PRE-EXCAVATION
CHECK LIST
DO NOT DIG WITHOUT LOCATE MARKS**

Complete and sign this sheet prior to excavation taking place.

BEFORE YOU LEAVE THE SHOP OBTAIN LOCATE NUMBERS AND:

- Check to see if locates has been completed (look at due date).
- Make sure you have a field sketch or if one was left at job site.

If you do not have what you need as listed above, do not leave the shop. See your Supervisor

ON THE JOB SITE

Pre-Survey (checking for locates)

- Check for field sketch.
- Check for all facility marks on ground.
- ___ Verify all service feeds from buildings and homes and that they have been ___ located and/or that they are aerial.
- ___ Draw a sketch of the marked facilities for future use.
- ___ Check for any visible signs of pedestal, riser, and new trench lines that may have been missed in your dig area.
- ___ Check to make sure that dig area is defined and is same on locate sketch when possible.
- ___ Check for any private facilities not located. If they are not located, locate them or contact someone to get them located.
- ___ If there are high priority facilities in your dig area, make sure facility owner/locator is on job site and/or has been contacted for advice

If lines are not located completely, consult locate card and contact responsible party.

Public and Private Utilities

- Ask for assistance from homeowner and utilize locating equipment and use common sense.
- Locate septic lines.
- Locate water yard lines.
- Locate private power lines to sheds, wells, invisible fences, etc.
- Locate private gas or propane lines.
- Locate sprinkler lines and heads and drip systems.
- Draw a sketch of locations for all private facilities on job site.
- Locate telecommunication cable (TV, Telephone, fiber optics, etc.)

EXCAVATING

- If paralleling or working on a critical or high priority line, pot hole or use locating equipment to expose and verify location and depth of facility every 100'.
- Hand dig within 24 inches (or as required in your state) of lines, peds, pole risers, meters or other

structures.

- Bore away from facilities.
- Verify depth of any facilities boring across, change route or depth as required, notify supervisor.
- Do not place excavated dirt on locate marks, flags, whiskers, etc.
- Support all lines exposed during excavation to avoid kinks or other damage.

BACKFILLING

- Shade all lines placed or exposed with good fill dirt.
- Verify all fill dirt is free from rocks, cable trash, crew trash, and large dirt clods.

PLEASE DIG SAFELY

As an excavator, you are responsible for verifying that all facilities within the dig area have been located.

You are responsible for locating all private and public facilities. Have the homeowner assist you if needed.

COMPLETED BY: _____

Date: _____

Construction Facility Damage Report

_____ of _____

CONSTRUCTION FACILITY DAMAGE REPORT

DATE OF REPORT _____

DATE AND TIME OF DAMAGE _____

MACHINE OPERATOR _____

TICKET # _____

DATE OF LOCATE _____

NAME OF LOCATE COMPANY _____

FACILITY OWNER _____

FACILITY DAMAGED _____ SIZE _____

LIVE OR ABANDONED _____

LOCATE ACCURATE YES ___ NO ___

MEASUREMENT OFF BY FEET INCHES

LOCATES _____ PAINTED _____ FLAGGED _____

PICTURES TAKEN YES ___ NO ___

HOW MANY TAKEN _____

LOCATE SKETCH ATTACHED YES ___ NO ___

WAS LOCATE SKETCH ON JOB SITE YES ___ NO ___

WAS HAND DIG COMPLETED 24" EACH SIDE OF MARK _

WAS LINE FOUND AND EXPOSED BY HAND _____

DAMAGE BY HAND OR MACHINE _____

CAUSE CODE _____

NAME OF MACHINE OPERATORS SUPERVISOR _____

WHAT HAPPENED TO CAUSE THIS DAMAGE

WHY DID THIS HAPPEN

WHAT IS BEING DONE TO INSURE THIS WILL NOT HAPPEN AGAIN

COMMENTS ON DAMAGES

MACHINE OPERATORS SIGNATURE _____

DATE _____

SUPERVISOR SIGNATURE _____

DATE _____

MANAGER SIGNATURE _____

DATE _____

OK TO PAY _____

DATE ____/____/____

DEPT. CODE _____

CLAIM NUMBER: _____

AMOUNT PAID: _____

DATE CLOSED: _____

CHECK NUMBER: _____

P.O. NUMBER: _____

CAUSE CODES LOCATE ERROR

- L01 Facility not marked
- L02 Abandoned facility
- L03 Mark off, but facility was not damaged
- L04 Locate marks off
- L05 Other (Explain)

CAUSE CODES DIG ERROR

- D02 Out of dig area
- D03 No locate requested
- D04 Expired locate
- D05 Digging prior to locate
- D06 Hit on locate - within 24" of mark
- D07 Marks destroyed - drawing incorrect
- D08 Unable to investigate/not notified
- D09 Found all cables marked
- D10 Other (Explain)

WELDING AND CUTTING

A. GENERAL

The company will ensure that work practices that involve Welding, Cutting and Brazing equipment/operations are evaluated to determine if proper safety precautions are instituted. The Occupational Safety and Health Administration (OSHA) recommends that certain guidelines be adhered to regarding these hazards. Our training program is intended to address comprehensively the issues of; using, evaluating and identifying the specific hazards where hot work is performed, communicating information concerning these hazards, and establishing appropriate procedures, and protective measures for our employees.

B. RESPONSIBILITY

The Operation Manager is solely responsible for all aspects of this program and has full authority to make necessary decisions to ensure success of the program. The company has expressly authorized the Safety Coordinator to halt any operation where there is danger of serious personal injury.

FIRE PREVENTION AND PROTECTION

Fire and explosion pose a serious risk to our employees during welding, cutting, and brazing operations. Sparks can travel as much as 35', and spatter can bounce on the floor or fall through openings creating hazards in other work areas of our facility.

1. BASIC SAFETY PRECAUTIONS. The below listed basic safety precautions will be followed by all employees performing welding, cutting, brazing operations. The basic precautions for fire prevention in welding or cutting work are:
 - a. Fire hazards. If the object to be welded or cut cannot readily be moved, all movable fire hazards in the vicinity shall be taken to a safe place.
 - b. Guards. If the object to be welded or cut cannot be moved and if all the fire hazards cannot be removed, then guards shall be used to confine the heat, sparks, and slag, and to protect the immovable fire hazards.
 - c. Restrictions. If the requirements stated for Fire hazards and Guards cannot be followed then welding and cutting shall not be performed.

2. SPECIAL PRECAUTIONS. When the nature of the work to be performed requires the use of guarding devices certain additional precautions may be necessary:
 - a. Combustible material. Wherever there are floor openings or cracks in the flooring that cannot be closed, precautions shall be taken so that no readily combustible materials on the floor below will be exposed to sparks which might drop through the floor. The same precautions shall be observed with regard to cracks or holes in walls, open doorways and open or broken windows.
 - b. Fire extinguishers. Suitable fire extinguishing equipment shall be maintained in a state of readiness for instant use. Such equipment may consist of pails of water, buckets of sand, hose or portable extinguishers depending upon the nature and quantity of the combustible material

- exposes.
- c. Fire watch.
 - 1) Fire watchers shall be required whenever welding or cutting is performed in locations where other than a minor fire might develop, or any of the following conditions exist:
 - a) Appreciable combustible material, in building construction or contents, closer than 35' to the point of operation.
 - b) Appreciable combustibles are more than 35' away but are easily ignited by sparks.
 - c) Wall or floor openings within a 35' radius expose combustible material in adjacent areas including concealed spaces in walls or floors.
 - d) Combustible materials are adjacent to the opposite side of metal partitions, walls, ceilings, or roofs and are likely to be ignited by conduction or radiation.
 - 2) Fire watchers shall have fire extinguishing equipment readily available and be trained in its use. They shall be familiar with facilities for sounding an alarm in the event of a fire. They shall watch for fires in all exposed areas, try to extinguish them only when obviously within the capacity of the equipment available, or otherwise sound the alarm. A fire watch shall be maintained for at least a half hour after completion of welding or cutting operations to detect and extinguish possible smoldering fires.
 - d. Authorization. Before cutting or welding is permitted, the area shall be inspected by the individual responsible for authorizing cutting and welding operations. He/she shall designate precautions to be followed in granting authorization to proceed preferably in the form of a written permit.
 - e. Floors. Where combustible materials such as paper clippings, wood shavings, or textile fibers are on the floor, the floor shall be swept clean for a radius of 35'. Combustible floors shall be kept wet, covered with damp sand, or protected by fire-resistant shields. Where floors have been wet down, personnel operating arc welding or cutting equipment shall be protected from possible shock.
 - f. Prohibited areas. Cutting or welding shall not be permitted in the following situations:
 - 1) In areas not authorized by management.
 - 2) In sprinklered buildings while such protection is impaired.
 - 3) In the presence of explosive atmospheres (mixtures of flammable gases, vapors, liquids, or dusts with air), or explosive atmospheres that may develop inside uncleaned or improperly prepared tanks or equipment which have previously contained such materials, or that may develop in areas with an accumulation of combustible dusts.
 - 4) In areas near the storage of large quantities of exposed, readily ignitable materials such as bulk sulfur, baled paper, or cotton.
 - g. Relocation of combustibles. Where practicable, all combustibles shall be relocated at least 35' from the work site. Where relocation is impracticable, combustibles shall be protected with flame-proofed covers or otherwise shielded with metal or asbestos guards or curtains.
 - h. Ducts. Ducts and conveyor systems that might carry sparks to distant combustibles shall be suitably protected or shut down.
 - i. Combustible walls. Where cutting or welding is done near walls, partitions, ceiling, or roof of combustible construction, fire-resistant shields or guards shall be provided to prevent ignition.
 - j. Noncombustible walls. If welding is to be done on a metal wall, partition, ceiling, or roof, precautions shall be taken to prevent ignition of combustibles on the other side, due to conduction or radiation, preferably by relocating combustibles. Where combustibles are not relocated, a fire watch on the opposite side from the work shall be provided.
 - k. Combustible cover. Welding shall not be attempted on a metal partition, wall, ceiling, or roof having a combustible sandwich-type panel construction.
 - l. Pipes. Cutting or welding on pipes or other metal in contact with combustible walls, partitions, ceilings or roofs shall not be undertaken if the work is close enough to cause ignition by conduction.

- m. Management. Management shall recognize its responsibility for the safe usage of all cutting and welding equipment and:
 - 1) Ensure that all cutters, welders and their supervisors are suitably trained in the safe operation of their equipment.
 - 2) Advise all contractors about flammable materials or hazardous conditions of which they may not be aware.
- n. Supervisor. The first line supervisor:
 - 1) Shall be responsible for the safe handling and use of the cutting or welding equipment.
 - 2) Shall determine the combustible materials and hazardous areas present or likely to be present in the work location.
 - 3) Shall protect combustibles from ignition by the following:
 - a) Have the work moved to a location free from dangerous combustibles.
 - b) If the work cannot be moved, have the combustibles moved to a safe distance from the work or have the combustibles properly shielded against ignition.
 - c) See that cutting and welding are so scheduled that any processes or operations that might expose combustibles to ignition are not started during cutting or welding.
 - 4) Shall secure authorization before the cutting or welding operations begins.
 - 5) Shall ensure that fire protection and extinguishing equipment are properly located at the site.
 - 6) Where fire watches are required, he/she shall see that they are available at the site.
- o. Fire prevention precautions. Cutting or welding shall be permitted only in areas that are or have been made fire safe. When work cannot be moved practically, as in most construction work, the area shall be made safe by removing combustibles or protecting combustibles from ignition sources.

3. WELDING OR CUTTING CONTAINERS.

- a. Used containers. No welding, cutting, or other hot work shall be performed on used drums, barrels, tanks, or other containers until they have been cleaned so thoroughly as to make absolutely certain that there are no flammable materials present or any substances such as greases, tars, acids, or other materials which when subjected to heat, might produce flammable or toxic vapors. Any pipe lines or connections to the drum or vessel shall be disconnected or blanked.
- b. Venting and purging. All hollow spaces, cavities or containers shall be vented to permit the escape of air or gases before preheating, cutting or welding. Purging with inert gas is recommended.

4. CONFINED SPACES.

- a. Accidental contact. When arc welding is to be suspended for any substantial period of time, such as during lunch or overnight, all electrodes shall be removed from the holders and the holders carefully located so that accidental contact cannot occur and the machine be disconnected from the power source.
- b. Torch valve. In order to eliminate the possibility of gas escaping through leaks or improperly closed valves, when gas welding or cutting, the torch valves shall be closed and the gas supply to the torch positively shut off at some point outside the confined area whenever the torch is not to be used for a substantial period of time, such as during lunch hour or overnight. Where practicable, the torch and hose shall also be removed from the confined space.

PROTECTION OF PERSONNEL

1. GENERAL

- a. Railings. Employee's working on platforms, scaffolds, or runways shall be protected against falling. This may be accomplished by the use of railings, safety belts, life lines, or some other equally effective safeguards.
- b. Welding cables. Employees shall place welding cables and other equipment so that it is clear of passageways, ladders, and stairways.

2. EYE PROTECTION

- a. Selection
 - 1) Helmets or hand shields shall be used during all arc welding or arc cutting operations, excluding submerged arc welding. Helpers or attendants shall be provided with proper eye protection.
 - 2) Goggles or other suitable eye protection shall be used during all gas welding or oxygen cutting operations. Spectacles without side shields, with suitable filter lenses are permitted for use during gas welding operation on light work, for torch brazing or for inspection.
 - 3) All operators and attendants of resistance welding or resistance brazing equipment shall use transparent face shields or goggles, depending on the particular job, to protect their faces or eyes, as required.
 - 4) Eye protection in the form of suitable goggles shall be provided where needed for brazing operations.
- b. Specifications for protectors
 - 1) Helmets and hand shields shall be made of material, which is an insulator for heat and electricity. Helmets, shields and goggles shall be not readily flammable and shall be capable of withstanding sterilization.
 - 2) Helmets and hand shields shall be arranged to protect the face, neck and ears from direct radiant energy from the arc.
 - 3) Helmets shall be provided with filter plates and cover plates designed for easy removal.
 - 4) All parts shall be constructed of a material, which will not readily corrode or discolor the skin.
 - 5) Goggles shall be ventilated to prevent fogging of the lenses as much as practicable.
 - 6) All glass for lenses shall be tempered, substantially free from streaks, air bubbles, waves, and other flaws. Except when a lens is ground to provide proper optical correction for defective vision, the front and rear surfaces of lenses and windows shall be smooth and parallel.
 - 7) Lenses shall bear some permanent distinctive marking by which the source and shade may be readily identified.
 - 8) The following is a guide for the selection of the proper shade numbers. These recommendations may be varied to suit the individual's needs.

Welding Operation	Shade No.
Shielded metal-arc welding: 1/16-, 3/32-, 1/8-, 5/32-inch electrodes	10
Gas-shielded arc welding (nonferrous): 1/16-, 3/32-, 1/8-, 5/32-inch electrodes	11
Gas-shielded arc welding (ferrous): 1/16-, 3/32-, 1/8-, 5/32-inch electrodes	12
Shielded metal-arc welding:	

3/16-, 7/32-, 1/4 -inch electrodes	12
5/16-, 3/8-inch electrodes	14
Atomic hydrogen welding	10-14
Carbon arc welding	14
Soldering	2
Torch brazing	3 or 4
Light cutting, up to 1 inch	3 or 4
Medium cutting, 1 inch to 6 inches	4 or 5
Heavy cutting, 6 inches or over	5 or 6
Gas welding (light) up to 1/8 inch	4 or 5
Gas welding (medium) 1/8 inch to 1/2 inch	5 or 6
Gas welding (heavy) 1/2 inch and over	6 or 8

NOTE: In gas welding or oxygen cutting where the torch produces a high yellow light, it is desirable to use a filter or lens that absorbs the yellow or sodium line in the visible light of the operation.

- 9) All filter lenses and plates purchased by your company shall meet the test for transmission of radiant energy prescribed by ANSI Z87.1—1968—American National Standard Practice for Occupational and Educational Eye and Face Protection.
- c. Protection from arc welding rays. Where the work permits, the welder shall be enclosed in an individual booth painted with a finish of low reflectivity such as zinc oxide (an important factor for absorbing ultraviolet radiation) and lamp black, or shall be enclosed with noncombustible screens similarly painted. Booths and screens shall permit circulation of air at floor level. Workers or other persons adjacent to the welding areas shall be protected from the rays by noncombustible or flameproof screens or shields or shall be required to wear appropriate goggle.

3. PROTECTIVE CLOTHING.

General requirements. Supervisors will ensure that employees exposed to the hazards created by welding, cutting, or brazing operations be protected by personal protective equipment in accordance with the requirements of 29 CFR 1910.132 (Personal Protective Equipment, General Requirements). Appropriate protective clothing required for any welding operation will vary with the size, nature and location of the work to be performed.

4. WORK IN CONFINED SPACES.

- a. General. As used herein, confined space is intended to mean a relatively small or restricted space such as a tank, boiler, pressure vessel, or small compartment of a ship.
- b. Ventilation. Ventilation is a prerequisite to work in confined spaces. Your company's confined space procedures will delineate ventilation requirements for specific operations where welding or cutting is required.
- c. Securing cylinders and machinery. When welding or cutting is being performed in any confined spaces that gas cylinders and welding machines shall be left on the outside. Before operations are started, heavy portable equipment mounted on wheels shall be securely blocked to prevent accidental movement.
- d. Lifelines. Where a welder must enter a confined space through a manhole or other small opening, means shall be provided for quickly removing him in case of emergency. When safety belts and lifelines are used for this purpose, they shall be so attached to the welder's body that his body cannot be jammed in a small exit opening. An attendant with a pre-planned rescue procedure (see company confined space procedures) shall be stationed outside to observe the welder at all times

- and be capable of putting rescue operations into effect.
- e. Electrode removal. When arc welding is to be suspended for any substantial period of time, such as during lunch or overnight, all electrodes shall be removed from the holders and the holders carefully located so that accidental contact cannot occur and the machine disconnected from the power source.
 - f. Gas cylinder shutoff. In order to eliminate the possibility of gas escaping through leaks of improperly closed valves, when gas welding or cutting, the torch valves shall be closed and the fuel-gas and oxygen supply to the torch positively shut off at some point outside the confined area whenever the torch is not to be used for a substantial period of time, such as during lunch hour or overnight. Where practicable the torch and hose shall also be removed from the confined space.
 - g. Warning signs. After welding operation are completed, the welder shall mark the hot metal or provide some other means of warning other workers.

HEALTH PROTECTION AND VENTILATION

1. GENERAL

- a. Contamination. The requirements for contamination control have been established on the basis of the following three factors in arc and gas welding which govern the amount of contamination to which welders may be exposed:
 - 1) Dimensions of space in which welding is to be done (with special regard to height of ceiling).
 - 2) Number of welders.
 - 3) Possible evolution of hazardous fumes, gases, or dust according to the metals involved.
- b. Screens. When welding must be performed in a space entirely screened on all sides, the screens shall be so arranged that no serious restriction of ventilation exists. It is desirable to have the screens so mounted that they are about 2' (0.61m) above the floor unless the work is performed at so low a level that the screen must be extended nearer to the floor to protect nearby workers from the glare of welding.
- c. Maximum allowable concentration. Local exhaust or general ventilating systems shall be provided and arranged to keep the amount of toxic fumes, gases, or dusts below the maximum allowable concentration as specified in 29 CFR 1910.1000 (Toxic and Hazardous Substances).
- d. Precautionary labels. A number of potentially hazardous materials are employed in fluxes, coatings, covering, and filler metals used in welding and cutting or are released to the atmosphere during welding and cutting. Supervisors will ensure employees under their control are familiar with the Material Safety Data Sheets (MSDS) applicable to the welding materials they are using.

2. VENTILATION FOR GENERAL WELDING AND CUTTING.

- a. General. Mechanical ventilation shall be provided when welding or cutting is done on metals other than the following; Fluorine compounds, Zinc, Lead, Beryllium, Cadmium, Mercury, and stainless steels.
 - 1) In a space of less than 10,000 cubic feet per welder.
 - 2) In a room having a ceiling height of less than 16 feet
 - 3) In confined spaces or where the welding space contains partitions, balconies, or other structural barriers to the extent that they significantly obstruct cross ventilation.
- b. Minimum rate. Such ventilation shall be at the minimum rate of 2,000 cubic feet per minute per welder, except where local exhaust hoods and booths provide an equivalent or better rate, or airline respirators approved by the Mine Safety and Health Administration and the National Institute for Occupational Safety and Health, pursuant to the provisions of 30 CFR part 11, are

provided. Natural ventilation is considered sufficient for welding or cutting operations where the following restrictions are not present.

- 1) In a space of less than 10,000 cubic feet per welder.
- 2) In a room having a ceiling height of less than 16 feet.
- 3) In confined spaces or where the welding space contains partitions, balconies, or other structural barriers to the extent that they significantly obstruct cross ventilation.

3. LOCAL EXHAUST HOODS AND BOOTHS. Mechanical local exhaust ventilation may be by means of either of the following:

- a. Hoods. Freely movable hoods intended to be placed by the welder as near as practicable to the work being welded and provided with a rate of air-flow sufficient to maintain a velocity in the direction of the hood of 100 linear feet per minute in the zone of welding when the hood is at its most remote distance from the point of welding. The rates of ventilation required to accomplish this control velocity using a 3 inch wide flanged suction opening are shown in the following table:

Welding Zone	Minimum air flow *(1) cubic feet/ minute	Duct diameter, inches *(2)
4 to 6 inches from arc to torch	150	3
6 to 8 inches from arc to torch	275	3 ½
8 to 10 inches form arc to torch	425	4 ½
10 to 12 inches from arc to torch	600	5 ½

*(1) When brazing with cadmium bearing materials or when cutting on such materials increased rates of ventilation may be required.

*(2) Nearest half-inch duct diameter bases on 4,000 feet per minute velocity in pipe.

- b. Fixed enclosure. A fixed enclosure with a top and not less than two sides which surround the welding or cutting operations and with a rate of airflow sufficient to maintain a velocity away from the welder of not less than 100 linear feet per minute.

4. VENTILATION IN CONFINED SPACES

- a. Air replacement. All welding and cutting operation carried on in confined spaces shall be adequately ventilated to prevent the accumulation of toxic materials or possible oxygen deficiency. This applies not only to the welder but also to helpers and other personnel in the immediate vicinity. All replacement air shall be clean and respirable.
- b. Airline respirators. In such circumstances where it is impossible to provide such ventilation, airline respirators or hose masks approved by the Mine Safety and Health Administration and the National Institute for Occupational Safety and Health, shall be used.
- c. Self-contained units. In areas immediately dangerous to life and health (IDLH), hose masks with blowers or self-contained breathing equipment shall be used. The breathing equipment shall be approved by the Mine Safety and Health Administration and the National Institute for Occupational Safety and Health.
- d. Outside helper. Where company welding operations are carried on in confined spaces and where welders and helpers are provided with hose masks, hose masks with blowers, or self-contained breathing equipment approved by the Mine Safety and Health Administration and the National Institute for Occupational Safety and Health, a worker shall be stationed on the outside of such confined spaces to insure the safety of those working within. This will be done in accordance with the company's confined space standard practice instructions.
- e. Oxygen for ventilation. Because of its flammable properties, Oxygen shall never be used for ventilation.

5. FLUORINE COMPOUNDS

- a. General. In confined spaces, welding or cutting involving fluxes, covering, or other materials which contain fluorine compounds shall be done in accordance with the safety precautions and work practices delineated on the MSDS.
- b. Maximum allowable concentration. The need for local exhaust ventilation or airline respirators for welding or cutting in other than confined spaces will depend upon the individual circumstances. However, experience has shown such protection to be desirable for fixed-location production welding and for all production welding on stainless steels.

6. ZINC.

- a. Confined spaces. In confined spaces welding or cutting involving zinc-bearing base or filler metals or metals coated with zinc-bearing materials shall be done in accordance with the "Ventilation in confined space" section of this program
- b. Indoors. Indoors, welding or cutting involving zinc-bearing base or filler metals coated with zinc-bearing materials shall be done in accordance with the "Local exhaust hoods and booths" section of this program.

7. LEAD

- a. Confined spaces. In confined spaces, welding involving lead-base metals (erroneously called lead-burning) shall be done in accordance with the "Ventilation in confined space" section of this program.
- b. Indoors. Indoors, welding involving lead-base metals shall be done in accordance with the "Local exhaust hoods and booths" section of this program.
- c. Local ventilation. In confined spaces or indoors, welding or cutting involving metals containing lead, other than as an impurity, or involving metals coated with lead-bearing materials, including paint shall be done using local exhaust ventilation or airline respirators. Outdoors such operations shall be done using respiratory protective equipment approved by the Mine Safety and Health Administration and the National Institute for Occupational Safety and Health. In all cases, workers in the immediate vicinity of the cutting operation shall be protected as necessary by local exhaust ventilation or airline respirators.

8. BERYLLIUM. Welding or cutting indoors, outdoors, or in confined spaces involving beryllium-containing base or filler metals shall be done using local exhaust ventilation and airline respirators unless atmospheric tests under the most adverse conditions have established that the workers' exposure is within the acceptable concentrations defined by 29 CFR 1910.1000. In all cases, workers in the immediate vicinity of the welding or cutting operations shall be protected as necessary by local exhaust ventilation or airline respirator.

9. CADMIUM

- a. General. Welding or cutting indoors or in confined spaces involving cadmium-bearing or cadmium-coated base metals shall be done using local exhaust ventilation or airline respirators unless atmospheric tests under the most adverse conditions have established that the workers' exposure is within the acceptable concentrations defined by 29 CFR 1910.1000. Outdoors such operation

shall be done using respiratory protective equipment such as fume respirators approved by the Mine Safety and Health Administration and the National Institute for Occupational Safety and Health.

- b. Confined space. Welding (brazing) involving cadmium-bearing filler metals shall be done using ventilation in accordance with the "Ventilation in confined space" and the "Local exhaust hoods and booths" section of this program.
10. MERCURY. Welding or cutting indoors or in a confined space involving metals coated with mercury-bearing materials including paint, shall be done using local exhaust ventilation or airline respirators unless atmospheric tests under the most adverse conditions have established that the workers' exposure is within the acceptable concentrations defined by 29 CFR 1910.1000. Outdoors such operations shall be done using respiratory protective equipment approved by the Mine Safety and Health Administration and the National Institute for Occupational Safety and Health.
 11. CLEANING COMPOUNDS
 - a. Manufacturer's instructions. In the use of cleaning materials, because of their possible toxicity or flammability, appropriate precautions such as manufacturer's instructions shall be followed.
 - b. Degreasing. Degreasing and other cleaning operations involving chlorinated hydrocarbons shall be so located that no vapors from these operations will reach or be drawn into the atmosphere surrounding any welding operation. In addition, trichloroethylene and perchlorethylene should be kept out of atmospheres penetrated by the ultraviolet radiation of gas-shielded welding operations.
 12. CUTTING OF STAINLESS STEELS. Oxygen cutting, using either a chemical flux or iron powder or gas-shielded arc cutting of stainless steel, shall be done using mechanical ventilation adequate to remove the fumes generated.
 13. FIRST-AID EQUIPMENT. First-aid equipment shall be available at all times. All injuries shall be reported to your supervisor in accordance with the policy as soon as possible for medical attention. First aid shall be rendered until medical attention can be provided.

INDUSTRIAL APPLICATIONS

1. TRANSMISSION PIPELINE
 - a. General. The requirements of the "Protection of personnel" and the "Health protection and ventilation" sections of this program shall be observed.
 - b. Field shop operations. Where field shop operations are involved for fabrication of fittings, river crossings, road crossings, and pumping and compressor stations the requirements of the "fire prevention and protection", "Protection of personnel" and the "Health protection and ventilation" sections of this program shall be observed.
 - c. Electric shock. When arc welding is performed in wet conditions, or under conditions of high humidity, special protection against electric shock shall be supplied.
 - d. Pressure testing. In pressure testing of pipelines, the workers and the public shall be protected against injury by the blowing out of closures or other pressure restraining devices. Also, protection shall be provided against expulsion of loose dirt that may have become trapped in the pipe.
 - e. Construction standards. The welded construction of transmission pipelines shall be conducted in accordance with the Standard for Welding Pipe Lines and Related Facilities, API Std. 1104--1968.
 - f. Flammable substance lines. The connection, by welding of branches to pipelines carrying

flammable substances shall be performed in accordance with Welding or hot Tapping on Equipment Containing Flammables, API Std. PSD No. 2201—1963.

- g. X-ray inspection. The use of X-rays and radioactive isotopes for the inspection of welded pipeline joints shall be carried out in conformance with the American National Standard Safety Standard for Non-Medical X-ray and Sealed Gamma-Ray Sources, ANSI Z54.1—1964

2. MECHANICAL PIPING SYSTEMS

- a. General. The requirements of the “Fire prevention and protection”, “Protection of personnel” and the “Health protection and ventilation” sections of this program shall be observed.
- b. X-ray inspection. The use of X-rays and radioactive isotopes for the inspection of welded piping joints shall be in conformance with the American National Standard Safety Standard for Non-Medical X-ray and Sealed Gamma-Ray Sources, ANSI Z54.1—1963.

TRAINING

- 1. Types of training. Supervisors will determine whether training required for specific jobs will be conducted in a classroom or on-the-job. The degree of training provided shall be determined by the complexity of the welding, brazing, or cutting requirements of the individual job and the associated hazards.
 - a. Initial training. Prior to job assignment, you shall provide training to supervisors, welders, cutters or any other related position to ensure that the hazards associated with all forms of burning, welding, brazing, and cutting operations including arc welding oxy/acetylene welding are understood by all employees related and that the knowledge and skills required for the safe application, usage, of work place equipment, are acquired by employees. The training shall include the following:
 - 1) Each authorized or supervisory employee shall receive training in the recognition of applicable hazards involved with particular job. The methods and means necessary for safe work.
 - 2) Each affected employee (welders and cutters) shall be instructed in the purpose and use of the confined space entry procedure (where needed).
 - 3) All other employees whose work operations are or may be in an area where welding, brazing, or cutting is to be performed, shall be instructed about the procedure, and about the prohibitions relating to working in that area.
 - 4) In addition, any personnel assigned must be trained and familiar with the operation and maintenance of equipment as per 1910.254 as well as procedure in AWS A6-1 involving the use of gas shielded or arc welding.
 - b. Refresher training. Scheduled refresher training will be conducted on an as needed basis.
 - 1) Retraining shall be provided for all authorized and affected employees whenever there is a change in their job assignments, a change in welding equipment, equipment or processes that present a new hazards, when their work takes them into hazardous areas, or when there is a change in the confined space entry procedures (when used).
 - 2) Additional retraining shall also be conducted whenever a periodic inspection reveals, or whenever you have reason to believe, that there are deviations from or inadequacies in the employee’s knowledge of known hazards, or use of equipment or procedures.
 - 3) The retraining shall reestablish employee proficiency and introduce new equipment, or revised control methods and procedures, as necessary.
 - c. Certification. The company shall certify that all employee training has been accomplished and is being kept up to date. The certification shall contain a synopsis of the training conducted, each employee’s name, job, and dates of training.

SELECTION AND USE OF WORK PRACTICES.

Supervisors shall develop and ensure use of standardized safety-related work practices to prevent injuries resulting from hot work accidents. The specific safety-related work practices shall be consistent with the nature and extent of the associated hot work hazards.

COMPRESSED GAS CYLINDERS

General requirements for safely handling compressed gas cylinders. The Interstate Commerce Commission defines a compressed gas as "that gas having a pressure in the container of 40 psia or greater at 70 degrees F, regardless of the pressure at 70 degrees F, having an absolute pressure exceeding 104 psi at 130 degrees F. In addition, it includes any liquid flammable material having a Reid vapor pressure exceeding 40 psia at 100 degrees F. A multitude of gases are available commercially, all having different properties and hazards associated with them. Their usage introduces hazards of flammability, explosion, chemical reaction, toxicity, and serious interference with manual fire-fighting efforts. The one common hazard shared by all compressed gases is pressure. There have been documented instances where a cylinder of gas has been damaged to such an extent that the instantaneous release of gas has rocketed the cylinder through a brick wall, propelling it several hundred feet away before coming to rest. Any and all workers in charge of oxygen and fuel gas supply, including piping systems must be trained and certified competent in the following:

a. Safe Use of Compressed Gas Cylinders

The following requirements must be observed when using, storing or handling compressed gas cylinders.

- 1) Know the cylinder contents; be sure identification labels are in place. Colors differ/also covers change.
- 2) Know the properties of the contents. MSDS's for the compressed gas being used, stored or handled should be reviewed with area personnel by the supervisor. The review should include information on physical data, fire and explosion data, reactivity, health hazards, special personal protection, and storage, spill and disposal procedures. MSDS's may be obtained from the supplier of the compressed gas, Safety Office, and/or purchasing.

b. Responsibility and Procedures

All operators of equipment should report any equipment defect or safety hazard and discontinue its use until it is safely repaired or replaced. If repairs are made they should be done by either the manufacturer or qualified person. The following are guidelines to follow in using and inspecting equipment.

- 1) Cylinder contents must be properly identified with appropriate label. Do not accept any cylinder that is not clearly labeled with its contents. Do not deface or remove any markings, labels, decals, tags, or stencil marks used for identification of content.
- 2) If a cylinder leaks and the leak cannot be remedied by simply tightening a valve gland or packing nut, close the valve and attach a tag stating that the cylinder was moved outdoors to a well ventilated location. If the gas is flammable or toxic, place an appropriate sign near the cylinder warning against these hazards and notify the Safety Observer or Supervisor. Notify the gas supplier and follow his instructions as to the immediate return of the cylinder.
- 3) Do not ship a leaking cylinder by a common or contract carrier whether charged or partially charged. Do not ship compressed gas cylinders that have been exposed to fire. Consult your

supplier for advice under these circumstances.

- 4) Before returning empty cylinders, close the valve and see that cylinder valve protective caps and outlet caps or plugs, if used, are replaced. Mark or tag cylinder as "EMPTY".
- 5) Cylinders containing compressed gases should not be subjected to a temperature above 125 degrees F. A flame should never be permitted to come in contact with any part of a compressed gas cylinder.
- 6) Cylinders should not be subjected to artificially created low temperatures without the approval of the supplier. Many steels undergo decreased ductility at low temperatures.
- 7) Never attempt to repair or alter cylinders, valves or safety relief devices.
- 8) Never use cylinders as rollers or supports, or for any purpose other than to contain the material as received.
- 9) Keep the cylinder valve closed at all times, except when the cylinder is in active use.
- 10) Notify the owner of the cylinder if any condition has occurred which might permit any foreign substance to enter the cylinder or valve, giving details and cylinder serial number.
- 11) Do not place cylinders where they might become part of an electric circuit. When the cylinders are used in conjunction with electric welding, precautions must be taken against accidentally grounding compressed gas cylinders and allowing them to be burned by an electric arc.
- 12) Do not repaint cylinders.
- 13) When in doubt about the proper handling of a compressed gas cylinder or its contents consult the Safety Director of the manufacturer or supplier of the gas.

c. Moving Cylinders

- 1) Where removable caps are provided for valve protection, such caps should be kept on cylinders at all times except when cylinders are in use.
- 2) Do not lift cylinder by the cap.
- 3) Never drop cylinders nor permit them to strike against each other or against the surface violently.
- 4) Never handle a cylinder with a lifting magnet. Slings, ropes, or chains should not be used unless provisions have been made on the cylinder for appropriate lifting attachments, such as lugs. A crane may be use when a safe cradle or platform is provided to hold the cylinders.
- 5) Avoid dragging or sliding cylinders. Use a suitable hand truck, fork truck, roll platform, or similar device with the cylinder firmly secured for transporting and loading/unloading.

d. Storing Cylinders

- 1) Cylinder storage areas should be prominently posted with the names of the gases to be stored. Cylinders should be grouped by types of gas.
- 2) Oxygen cylinders in storage shall be separated from fuel, gas cylinders or combustible materials (especially oil or grease) by a minimum of 20 feet or by a noncombustible barrier at least 5 feet high having a fire resistance rating of at least one-half hour.
- 3) Charged and empty cylinders should be stored separately with empty cylinders clearly marked.
- 4) Storage area shall be fire-resistant, dry and well ventilated.
- 5) Secure cylinders by chain or straps to a rigid support.
- 6) Inside storage of full containers shall not be located near exits, stairways, or in areas normally used or intended for the safe exit of people.

e. Using Cylinders

- 1) Secure to rigid support before using.

- 2) Use the regulator specified by the manufacturer for a special gas. Be sure the system pressure rating will handle regulator discharge pressure.
- 3) Insure that all connections are free of leaks. Never use a flame to detect flammable gas leaks, use leak detector or soapy water.
- 4) Do not use oil or grease on valves, reducers, regulators, or lines in an oxygen system.
- 5) Open cylinder valves slowly. Point the valve opening and/or the glass-covered gauge faced away from yourself or other persons. Close cylinder valves when stopping work, moving cylinders, or when cylinders are empty.
- 6) Never mix different gases in cylinder.
- 7) Acetylene cylinders should be used and stored in an upright position to avoid loss of acetone.

BLOOD BORNE PATHOGENS

Exposure Control Plan Access

Employees shall have access to a copy of the exposure control plan by request from their supervisor or the safety manager who will supply it in a reasonable time, place and manner.

Procedure Reviews and Updates

The exposure control procedure must be reviewed on an annual basis and updated whenever a new procedure, activity or function with the potential to expose employees to biohazards is introduced into a worksite.

Universal Precautions

Your employees shall observe universal precautions by treating all human blood and certain human body fluids as if they are known to be infectious for HIV, HBV and other pathogens even under circumstances where exposure is highly unlikely.

Exposure Controls

Exposure controls are designed to reduce or eliminate employee exposure to blood or potentially infectious materials and should be re-evaluated and revised if necessary on a regular basis to maximize their effectiveness in controlling employee exposure. Therefore:

- Hand washing facilities are readily available at all work locations except those that cannot support or simply do not have such facilities. In these cases, appropriate antiseptic solutions and / or towelettes are available for use.
- All sharps containers shall have a biohazard-warning label or a specific color to identify it as a biohazard, shall be resistant to punctures and shall be leak proof. The same characteristics shall apply to all secondary sharps containers.

Safe Work Practices

Safe work practices are designed to support exposure controls and further minimize or eliminate occupational exposure. Therefore:

- Employees must wash hands and other applicable body parts as soon as potentially contaminated gloves or other PPE are removed to further prevent contamination.
- If any part of the body has contact with blood or any other infectious material, employees must wash hands and other exposed body parts with soap and water immediately.
- Only trained and authorized personnel are allowed to handle sharps, sharps containers and any other potentially sharp and infectious needles or equipment.
- Activities such as applying makeup, handling contact lenses, smoking or any other hand and eye, mouth, nose, ear or other body part contact is prohibited in areas where exposure to biohazards is possible.
- Storage areas such as pantries, freezers, refrigerators and others that may contain potentially infectious materials shall not contain food or drink.
- All equipment and surfaces that have had contact with blood or other infectious materials must be properly cleaned and decontaminated.
- All biological specimens must be contained in leak proof containers for handling, storage and transport to minimize potential contact with other surfaces and employees.
- In cases where the exterior surface of the specimen container is contaminated; the container must be placed into another leak proof container, which shall be labeled as "for handling and storage".

- All emergency responder, first aid or other potentially infectious supplies must be disposed of immediately and appropriately after contamination.

Personal Protective Equipment (PPE)

PPE shall be provided by your company at no cost to the employee and must be of proper fit, adequate for the task at hand and readily available. Defective or damaged PPE must be discarded / replaced or repaired in order to ensure maximum effectiveness.

The following safe work practices shall be followed with regard to biohazards and PPE:

- Protective garments that are penetrated by blood or other infectious materials must be removed and properly disposed of immediately.
- PPE that may be contaminated must be removed and properly stored / contained before leaving the work area.
- PPE such as protective gloves must be worn whenever contact with potentially infectious material exposure is anticipated.
- Disposable PPE such as rubber gloves must be replaced as soon as practical when contamination has occurred or when they are rendered ineffective by a tear, puncture or other occurrence.
- Masks and eye protection (such as goggles, face shields, etc.) are used whenever splashes or sprays may generate droplets of infectious materials.
- Whenever infectious material splashes, sprays or other similar occurrences are possible, PPE such as face shields, goggles, head garments or other appropriate PPE shall be used to protect face, eyes etc.
- Adequate PPE must be used unless temporarily declined by the employee and approved by the safety manager.
- PPE should be cleaned, laundered & properly disposed of if contaminated.
- All PPE must be cleaned, maintained, used, stored and disposed of properly when applicable.

Post-Exposure Requirements

All potential blood or infectious material exposure incidents shall be investigated by the employer thoroughly to ensure that hazards are abated and that affected employees receive the necessary treatment needed to minimize the impact of potential or actual exposure.

All reported exposure incidents shall be formally investigated by the exposure control officer / safety manager or supervisor when the safety manager cannot be present. A detailed report of the incident outlining root cause, corrective actions and the current status of affected employees is then completed and reviewed by employer to help prevent re-occurrence. Additionally, the following confidential information shall be provided to exposed employees:

- All documentary reports and information of the exposure incident and its circumstances.
- The identity of the exposure source individual unless applicable laws prevent such identification.

Upon completion of the above procedures, the exposed employee shall be appointed to a qualified healthcare professional who will evaluate the exposed employee, provide information to the employee about his or her medical status and initiate treatment where applicable.

Employer shall provide the following information to the healthcare professional:

- A copy of the biohazards standard.
- A detailed description of the exposure incident.

- Additional information that is relevant to the healthcare professional.

The following information will be provided to the employer by the healthcare professional as a “written report” and copied to the exposed employee upon completion of the healthcare professional’s evaluation of exposed employee:

- If a Hepatitis B vaccination is recommended for the exposed employee.
- If the exposed employee has received the Hepatitis B vaccination since the incident.
- Verification that the exposed employee has received results information of the medical evaluation.
- Verification that the exposed employee was made aware of medical conditions caused by the exposure incident that require additional medical evaluation or treatment.

* All other medical information remains confidential and will not be a part of the written report.

* The Hepatitis B vaccine will be made available to all employees with occupational exposure at no cost.

HEAT ILLNESS AND PREVENTION

All managers and supervisors will implement and maintain the Heat Illness Program in their respective work areas. High heat procedures are to be followed when the temperature exceeds 95 degrees Fahrenheit. High heat procedures shall include, but are not limited to:

- Effective communication by voice, observation or electronic means,
- Will observe employees for alertness and signs/symptoms of heat illness often,
- Reminding employees to drink water throughout the shift,
- Closely supervise new employees for their first 14 days of employment,
- The provisions of this procedure.

Provision of Water

Employees shall have access to potable drinking water. Where it is not plumbed or otherwise continuously supplied, it shall be provided in sufficient quantity at the beginning of the work shift.

Access to Shade

Employees must have access to shade. At or below 85 degrees Fahrenheit the employee shall have timely access to shade upon request. For temperatures at or above 85 degrees Fahrenheit, one or more areas with shade shall be provided at all times while employees are present. There should be enough shade for at least 25% of employees on the shift at any one time to use.

Employees suffering from heat illness or those who believe a preventative recovery period is needed shall be provided access to an area with shade that is either open to the air or provided with ventilation or cooling for a period of no less than five minutes. Such access to shade shall be permitted at all times. See definition of "Shade".

Written Procedures

The heat prevention program/procedures shall be in writing and shall be made available to employees.

Each work site shall develop site specific procedures which shall include the minimum:

- Make available at least 2 quarts of water per employee at the start of the shift. The supervisors or designated persons will monitor water containers every 30 minutes. Employees are encouraged to report to the supervisor/designated person water that is dirty or an inadequate water supply.
- Supervisors will provide frequent reminders to employees to drink frequently.
- Workers will be reminded every morning of the importance of frequent consumption of water throughout the shift during hot weather.
- Place water containers as close as possible to the workers.
- Water levels should not fall below the point that will provide adequate water for all employees during the time necessary to effect replenishment.
- Disposable/single use drinking cups will be provided to employees or provisions will be made to supply employees their own cups.
- Supervisors will set-up an adequate number of umbrellas, canopies or other portable devices at the start of the shift and will relocate them to be closer to the crew, as needed.
- Non-agricultural employers can use other cooling measures if they demonstrate that these methods are as effective

as shade.

Working hours will be modified to work during the cooler hours of the day, when possible.

More water and rest breaks will be provided when a modified or shorter work-shift is not possible.

Supervisors will continuously monitor all employees and stay alert to the presence of heat related symptoms.

Supervisors will carry cell phones or other means of communication, to ensure that emergency services can be called.

They will check that all means of communication are functional at the work-site prior to each shift.

Every morning, workers will be reminded about the address and directions to their work-site so as to inform medical responders.

All newly hired workers will be assigned a buddy or experienced coworker to ensure they receive proper training and are following the company procedures in regards to heat illness prevention.

SCAFFOLDS

General Requirements

When work cannot be performed safely from the ground, or from solid construction, scaffolds must be supplied and erected according to the applicable standards for the employees involved. In the case that ladders are used, the work must conform to ladder safety standards.

Scaffolds must be erected by a qualified individual (someone who can certify that the scaffolding is safe to use).

Scaffolds must be set on footings or anchored to material that is sound, rigid, and able to support the maximum intended load without settling or shifting. Never use unstable objects such as loose boards, barrels, or boxes to support scaffolds or planks.

Only use scaffolds (and components) that are capable supporting (without failure) at least four times the maximum intended load. All scaffold components must comply with OSHA requirements 29 CFR 1910.28 and 29 CFR 1926.451.

If using wood scaffold planks, they must be cross-supported every 8 feet. Cleat, wire or nail scaffold deck boards into place.

You must completely floor all working levels of scaffolds except where space is required for openings for internal ladders.

Maintenance of scaffolds and other components described in this program is required to keep them in safe condition. Never alter or move (horizontally) a scaffold that is occupied.

Immediately repair any damaged or weakened scaffold. Never use a damaged or weakened scaffold until repairs have been completed.

Never load a scaffold in excess of the working load that it is intended for.

Always use properly sized bolts in the construction of scaffolds, and use sufficient number at each connection to create the designed strength of the scaffold.

Always overlap platforms (minimum of 12 inches) and secure them from any movement.

Always provide an access ladder or equivalent safe access.

Always extend scaffold planks over their end supports by not less than 6 inches and not more than 18 inches.

Ensure that poles, legs, and uprights of scaffolds are plumb, and are rigidly braced and secured to prevent swaying and shifting.

Always apply a tag line to materials being hoisted onto a scaffold.

Always provide overhead protection workers on a scaffold if they are exposed to overhead hazards.

If a scaffold or platform is erected over 6 feet off the ground, always install toe boards and guardrails. Where workers are required to work or pass under the scaffold, always install a screen between the toe board and the guardrail (along the entire opening), consisting of No. 18 gauge wire one-half inch mesh or the equivalent.

Never perform work on a scaffold during storms or high winds.

Never perform work on a scaffold that is covered with snow or ice, unless all the snow and ice is removed and planking is

sanded to prevent slipping.

Do not accumulate tools, material, and debris on a scaffold such that it presents a hazard.

Inspections

Scaffolding must be inspected by a qualified individual as per the manufacturer's recommendations. The qualified individual must also conduct inspections prior to each use and periodically throughout each shift.

- A qualified individual inspects the scaffold after it is erected, prior to the start of the work day, and at the beginning of a shift change to ensure the scaffold is safe prior to and during use. At a minimum, the following shall be inspected:
 - Ensure there is no settling in the ground or surface footing.
 - Check for any signs of damage, missing pins, bolts and any locks and/or safety keepers on all main supports and cross braces.
 - Check for damage, proper placement and any possible movement of all walking surfaces and/or planks.
 - Check that all walkways and planks are secure to prevent movement.
- The inspection will ensure that the scaffold is stable, and movement is prevented.
- If a defect or damage to the scaffold is discovered during the inspection, the scaffold must be tagged out by the qualified individual. Use of the scaffold will be prohibited until the necessary repairs are made.

Mandatory Signs and Tags

Signs and tags must be visible at all times when performing work, and must be promptly removed or covered when the hazard are abated. Tags shall also be used when defective equipment or unsafe conditions are found.

The qualified individual will tag out any defective or unsafe equipment or conditions (e.g., improper footings) shall using a weather resistant tag that is secured to the scaffolding structure on all four sides.

Only use danger signs where an immediate hazard exists. To alert other workers of possible danger from falling objects, post danger signs in the immediate area of the scaffold.

Caution - To mark off a larger area around scaffolding and warn other workers to use caution, use signs and/or barricade tape.

Modifications

A qualified person must perform all modifications and repairs. This qualified person must be able to certify that the scaffolding is safe to use to ensure that non-qualified personnel do not create additional hazards.

Only employees who are trained and certified shall perform modifications or repairs. Unqualified employees who fail to comply may receive disciplinary action and or termination.

HAZARD IDENTIFICATION AND ASSESSMENT

To assist in the identification and correction of hazards, the company has developed the following procedures. These procedures are representative only and are not exhaustive of all the measures and methods that will be implemented to guard against injury from recognized and potential hazards in the workplace. As new hazards are identified or improved work procedures developed, they will be promptly incorporated into our Safety Manual. The following methods will be utilized to identify hazards in the workplace:

- Loss analysis of accident trends
- Accident investigation
- Employee observation
- Employee suggestions
- Regulatory requirements for our industry
- Outside agencies such as the fire department and insurance carriers
- Periodic safety inspections

Loss Analysis

Periodic loss analyses will be conducted by the safety program administrator. These will help identify areas of concern and potential job hazards. The results of these analyses will be communicated to management, supervision, and employees through safety meetings and other appropriate means.

Accident Investigations

All accidents and injuries will be investigated in accordance with the guidelines contained in this program. Accident investigations will focus on all causal factors and corrective action including the identification and correction of hazards that may have contributed to the accident.

Employee Observation

Superintendents and foremen shall be continually observing employees for unsafe actions and taking corrective action as necessary.

Employee Suggestions

Employees are encouraged to report any hazard they observe to their supervisor. No employee is to ever be disciplined or discharged for reporting any workplace hazard or unsafe condition. However, employees who do NOT report potential hazards or unsafe conditions that they are aware of will be subject to disciplinary action.

Regulatory Requirements

All industries are subject to government regulations relating to safety. Many of these regulations are specific to our type of business. Copies of pertinent regulations can be obtained from the Safety Program Administrator.

Outside Agencies

Several organizations may assist us in identifying hazards in our workplace. These include safety officers from other contractors, insurance carrier safety and health consultants, private industry consultants, the fire department, and State OSH Consultants.

Periodic Safety Inspections

Periodic safety inspections ensure that physical and mechanical hazards are under control and identify situations that may become potentially hazardous. Inspections shall include a review of the work habits of employees in all work areas. These inspections will be conducted by the Supervisor, Manager, Program Administrator or other designated individual.

Periodic safety inspections will be conducted:

- * When new substances, process, procedures or equipment are used.
- * When new or previously unrecognized hazards are identified.
- * Periodically by the Supervisor.
- * Periodically by the Safety Program Administrator.

These inspections will focus on both unsafe employee actions as well as unsafe conditions. The following is a partial list of items to be checked.

- The proper use, condition, maintenance and grounding of all electrically operated equipment.
- The proper use, condition, and maintenance of safeguards for all power-driven equipment.
- Compliance with the Code of Safe Practices.
- Housekeeping and personal protective equipment.
- Hazardous materials.
- Proper material storage.
- Provision of first aid equipment and emergency medical services.

Any and all hazards identified will be corrected as soon as practical in accordance with the company hazard correction policy.

If imminent or life threatening hazards are identified, which cannot be immediately corrected, all employees must be removed from the area, except those with special training required to correct the hazard, who will be provided necessary safeguards.

Documentation of Inspections

Safety inspections will be documented to include the following:

- Date on which the inspection was performed.
- The name and title of person who performed the inspection.
- Any hazardous conditions noted or discovered and the steps or procedures taken to correct them.
- Signature of the person who performed the inspection.

One copy of the completed form should be sent to the office. All reports shall be kept on file for a minimum of two (2) years.

HAZARD PREVENTION, CORRECTION, AND CONTROL

The following procedures will be used to evaluate, prioritize and correct identified safety hazards. Hazards will be corrected in order of priority: the most serious hazards will be corrected first.

Hazard Evaluation

Factors that will be considered when evaluating hazards include:

- * Potential severity - The potential for serious injury, illness or fatality
- * Likelihood of exposure - The probability of the employee coming into contact with the hazard
- * Frequency of exposure - How often employees come into contact with the hazard
- * Number of employees exposed
- * Possible corrective actions - What can be done to minimize or eliminate the hazard
- * Time necessary to correct - The time necessary to minimize or eliminate the hazard

Techniques for Correcting Hazards

1. Engineering Controls: Could include machine guarding, ventilation, noise reduction at the source, and provision of material handling equipment. These are the first and preferred methods of control.
2. Administrative Controls: The next most desirable method would include rotation of employees or limiting exposure time.
3. Personal Protective Equipment: Includes back support belts, hearing protection, respirators and safety glasses. These are often the least effective controls for hazards and should be relied upon only when other controls are impractical.

Documentation of Corrective Action

All corrective action taken to mitigate hazards should be documented. Depending on the circumstances, one of the following forms should be used:

- * Safety Contact Report
- * Safety Meeting Report
- * Memo or letter
- * Safety inspection form

All hazards noted on safety inspections will be rechecked on each subsequent inspection and notations made as to their status.

HAZARD COMMUNICATION PROGRAM

Introduction

It is company policy that the first consideration of work shall be the protection of the safety and health of all employees. We have developed this Hazard Communication Program to ensure that all employees receive adequate information about the possible hazards that may result from the various materials used in our operations. This Hazard Communication Program will be monitored by the Safety Program Administrator who will be responsible for ensuring that all facets of the program are carried out, and that the program is effective.

Our program consists of the following elements:

1. Hazardous material inventory.
2. Collection and maintenance of Material Safety Data Sheets.
3. Container labeling.
4. Employee training.

The following items are not required to be included in the program and are therefore omitted:

- * Foods, drugs, cosmetics or tobacco.
- * Untreated wood products.
- * Hazardous waste.
- * Consumer products packaged for sale to and use by the general public, provided that our exposure is not significantly greater than typical consumer exposure.

Hazardous Material Inventory

The Safety Program Administrator maintains a list of all hazardous materials used in our operations. This list contains the name of the product, the type of product (solvent, adhesive etc.) and the name and address of the manufacturer.

Material Safety Data Sheets (MSDS)

Copies of MSDS for all hazardous substances to which our employees may be exposed will be kept in a binder at the main office. These MSDS are available to all employees, at all times, upon request. Copies of the most commonly used products will also be kept by the Supervisor at the work site.

The Safety Program Administrator will be responsible for reviewing incoming MSDS for new and significant health/safety information. They will ensure that any new information is passed on to the affected employees.

The Safety Program Administrator will also review all incoming MSDS for completeness. If an MSDS is missing or obviously incomplete, a new MSDS will be requested from the manufacturer. Federal or State (if applicable) OSHA will be notified if a complete MSDS is not received and the manufacturer will not supply one.

New materials will not be introduced into the shop or field until a MSDS has been received. The purchasing department will make it an ongoing part of their function to obtain MSDS for all new materials when they are first ordered.

Container Labeling

No container of hazardous substances will be used unless the container is correctly labeled and the label is legible.

All chemicals in cans, bags, drums, pails, etc., will be checked by the receiving department to ensure the manufacturer's label is intact, is legible, and has not been damaged in any manner during shipment. Any containers found to have damaged labels will be held until a new label has been installed. New labels will be obtained from the manufacturer.

The label must contain:

- * The chemical name of the contents.
- * The appropriate hazard warnings.
- * The name and address of the manufacturer.

All secondary containers will be labeled as to their contents with a reference to the original label.

Employee Information and Training

All employees will be provided information and training on the following items through the company safety training program and prior to starting work with hazardous substances:

1. An overview of the requirements of the Hazard Communication Standard, including their rights under this regulation.
2. Information regarding the use of hazardous substances in their specific work areas.
3. The location and availability of the written hazard communication program. The program will be available from the Supervisor and Safety Program Administrator.
4. The physical and health hazards of the hazardous substances in use.
5. Methods and observation techniques used to determine the presence or release of hazardous substances in the work area.
6. The controls, work practices and personal protective equipment available for protection against possible exposure.
7. Emergency and first aid procedures to follow if employees are exposed to hazardous substances.
8. How to read labels and material safety data sheets to obtain the appropriate hazard information.

Hazardous Non-Routine Tasks

Infrequently, employees may be required to perform hazardous non-routine tasks. Prior to starting this work, each involved employee will be given information by his/her supervisor about hazards to which they may be exposed during such activity.

This information will include:

- * The specific hazards.
- * Protective/safety measures which must be utilized.
- * The measures the company has taken to lessen the hazards, including special ventilation, respirators, the presence of another employee, emergency procedures, etc.

Informing Outside Contractors and Vendors

To ensure that outside contractors are not exposed to our hazardous materials, and to ensure the safety of the contractor's

employees, it will be the responsibility of the Supervisor to provide outside contractors the following information:

- The hazardous substances under our control that they may be exposed to while at the work site.
- The precautions the contractor's employees must take to lessen the possibility of exposure.

We will obtain from outside contractors and vendors the name of any hazardous substances the contractor's employees may be using at a work site or bringing into our facility. The contractor must also supply a copy of the material safety data sheet relevant to these materials.

Employee Rights Under The Hazard Communication Standard

At any time, an employee has the right to:

- Access the MSDS folder, and the Hazard Communication Program.
- Receive a copy of any environmental sampling data collected in the workplace.
- See their employment medical records upon request.

FIRST AID AND MEDICAL EMERGENCY PROCEDURES

The company will ensure the availability of emergency medical services for its employees at all times. We will also ensure the availability of a suitable number of appropriately trained persons to render first aid. The Safety Program Administrator will maintain a list of trained individuals and take steps to provide training for those that desire it.

First-Aid Kits

Every work site shall have access to at least one first-aid kit in a weatherproof container. The first-aid kit will be inspected regularly to ensure that it is well stocked, in sanitary condition, and any used items are promptly replaced. The contents of the first-aid kit shall be arranged to be quickly found and remain sanitary. First-aid dressings shall be sterile and in individually sealed packages.

Drugs, antiseptics, eye irrigation solutions, inhalants, medicines, or proprietary preparations shall not be included in first-aid kits unless specifically approved, in writing, by an employer-authorized, licensed physician. Other supplies and equipment, if provided, shall be in accordance with the documented recommendations of an employer-authorized licensed physician upon consideration of the extent and type of emergency care to be given based upon the anticipated incidence and nature of injuries and illnesses and availability of transportation to medical care.

First Aid

The designated first aid person on each site will be available at all times to render appropriate first aid for injuries and illnesses. Proper equipment for the prompt transportation of the injured or ill person to a physician or hospital where emergency care is provided, or an effective communication system for contacting hospitals or other emergency medical facilities, physicians, ambulance and fire services, shall also be provided. The telephone numbers of the following emergency services in the area shall be posted near the job telephone, or otherwise made available to the employees where no job site telephone exists:

1. A company authorized physician or medical clinic, and at least one alternate if available.
2. Hospitals.
3. Ambulance services.
4. Fire-protection services.

Prior to the commencement of work at any site, the Supervisor or Manager shall locate the nearest preferred medical facility and establish that transportation or communication methods are available in the event of an employee injury.

Each employee shall be informed of the procedures to follow in case of injury or illness through our new employee orientation program, Code of Safe Practices, and safety meetings.

Where the eyes or body of any person may be exposed to injurious or corrosive materials, suitable facilities for drenching the body or flushing the eyes with clean water shall be conspicuously and readily accessible.

Accident Procedures

These procedures are to be followed in the event of an employee injury in the course of employment.

1. For severe accidents call 911 and request the Paramedics.
2. Employees must report all work related injuries to their Supervisor immediately. Even if they do not feel that it requires medical attention. Failure to do so may result in a delay of Workers' Compensation benefits and disciplinary action.
3. The Supervisor, employee, and first aid person, should determine whether or not outside medical attention is needed. When uncertainty exists on the part of any individual, the employee should be sent for professional medical care.
4. If medical attention is not desired or the employee refuses treatment, you must still fill out a company "Accident Report" in case complications arise later.
5. In all cases, if the employee cannot transport himself or herself for any reason, transportation should be provided.
6. In the event of a serious accident involving hospitalization for more than 24 hours, amputation, permanent disfigurement, loss of consciousness or death, phone contact should be made with the main office. Contact must also be made with the nearest Federal or State (if applicable) OSHA office.

ACCIDENT / EXPOSURE INVESTIGATION

The Supervisor, Manager, or other designated individual will investigate all work-related accidents in a timely manner. This includes minor incidents and "near accidents", as well as serious injuries. An accident is defined as any unexpected occurrence that results in injury to personnel, damage to equipment, facilities, or material, or interruption of normal operations.

Responsibility for Accident Investigation

Immediately upon being notified of an accident, the Supervisor, Manager, or other designated individual shall conduct an investigation. The purpose of the investigation is to determine the cause of the accident and corrective action to prevent future reoccurrence; not to fix blame or find fault. An unbiased approach is necessary in order to obtain objective findings.

The Purpose of Accident Investigations:

- * To prevent or decrease the likelihood of similar accidents.
- * To identify and correct unsafe work practices and physical hazards. Accidents are often caused by a combination of these two factors.
- * To identify training needs. This makes training more effective by focusing on factors that are most likely to cause accidents.

What Types of Incidents Do We Investigate?

- * Fatalities
- * Serious injuries
- * Minor injuries
- * Property damage
- * Near misses

Procedures for Investigation of Accidents

Immediately upon being notified of an accident the Supervisor, Manager, or other designated individual will:

1. Visit the accident scene, as soon as possible, while facts and evidence are still fresh and before witnesses forget important details and to make sure hazardous conditions to which other employees or customers could be exposed are corrected or have been removed;
2. Provide for needed first aid or call 911 for the injured employee(s).
3. If possible, interview the injured worker at the scene of the accident and verbally "walk" him or her through a re-enactment. All interviews should be conducted as privately as possible. Interview all witnesses individually and talk with anyone who has knowledge of the accident, even if they did not actually witness it.
4. Report the accident to the main office. Accidents will be reported by the office to the insurance carrier within 24 hours. All serious accidents will be reported to the carrier as soon as possible.

5. Consider taking signed statements in cases where facts are unclear or there is an element of controversy.
6. Thoroughly investigate the accident to identify all accident causes and contributing factors. Document details graphically. Use sketches, diagrams and photos as needed. Take measurements when appropriate.
7. All accidents involving death, disfigurement, amputation, loss of consciousness or hospitalization for more than 24 hours must be reported to Federal or State (if applicable) OSHA immediately.
8. Focus on causes and hazards. Develop an analysis of what happened, how it happened, and how it could have been prevented. Determine what caused the accident itself, not just the injury.
9. Every investigation must also include an action plan. How can such accidents be prevented in the future?
10. In the event a third party or defective product contributed to the accident, save any evidence as it could be critical to the recovery of claim costs.

Accurate & Prompt Investigations

- * Ensures information is available
- * Causes can be quickly corrected
- * Helps identify all contributing factors
- * Reflects management concern
- * Reduces chance of recurrence

Investigation Tips

- * Avoid placing blame
- * Document with photos and diagrams, if needed
- * Be objective, get the facts
- * Reconstruct the event
- * Use open-ended questions

Questions to Ask

When investigating accidents, open-ended questions such as who?, what?, when?, where?, why?, and how? will provide more information than closed-ended questions such as "Were you wearing gloves?"

Examples include:

- * How did it happen?
- * Why did it happen?
- * How could it have been prevented?
- * Who was involved?
- * Who witnessed the incident?
- * Where were the witnesses at the time of the incident?
- * What was the injured worker doing?
- * What was the employee working on?
- * When did it happen?
- * When was the accident reported?
- * Where did it happen?

- * Why was the employee assigned to do the job?

The single, most important question that must be answered as the result of any investigation is:

"What do you recommend be done (or have you done) to prevent this type of incident from recurring?"

Once the Accident Investigation is Completed

- * Take or recommend corrective action
- * Document corrective action
- * Management and the Safety Program Administrator will review the results of all investigations
- * Consider safety program modifications

Information obtained through accident investigations can be used to update and improve our current program.

TRAINING AND INSTRUCTION

Every new employee will be given instruction by their Supervisor in the general safety requirements of their job. A copy of our Code of Safe Practices shall also be provided to each employee.

Managers, Supervisors, and employees will be trained at least twice per year on various accident prevention topics.

Training provides the following benefits:

- * Makes employees aware of job hazards
- * Teaches employees to perform jobs safely
- * Promotes two way communication
- * Encourages safety suggestions
- * Creates interest in the safety program
- * Fulfills Federal or State (if applicable) OSHA requirements

Employee training will be provided at the following times:

1. All new employees will receive a safety orientation their first day on the job.
2. All new employees will be given a copy of the Code of Safe Practices and required to read and sign for it.
3. All employees given a new job assignment for which training has not been previously provided will be trained before beginning the new assignment.
4. Whenever new substances, processes, procedures or equipment that represent a new hazard are introduced into the workplace.
5. Whenever the company is made aware of a new or previously unrecognized hazard.
6. Whenever management believes that additional training is necessary.
7. After all serious accidents.
8. When employees are not following safe work rules or procedures.

Training topics will include, but not be limited to:

- * Employee's safety responsibility
- * General safety rules
- * Code of Safe Practices
- * Safe job procedures
- * Ergonomics
- * Use of hazardous materials
- * Use of equipment
- * Emergency procedures
- * Safe lifting and material handling practices
- * Contents of safety program

Documentation of Training

All training will be documented on one of the following three forms.

New Employee Safety Orientation
Employee Safety Contact Form
Safety Meeting Report

The following training method should be used. Actual demonstrations of the proper way to perform a task are very helpful in most cases.

- * Tell them how to do the job safely
- * Show them how to do the job safely
- * Have them tell you how to do the job safely
- * Have them show you how to do the job safely

Follow up to ensure they are still performing the job safely

FIRE PREVENTION AND EMERGENCY ACTION PLAN

The company has developed the following emergency plan to cover those designated actions that must be taken to ensure employee safety from fire and during other emergencies. Any questions about this plan should be directed to The Safety Program Administrator.

Facility Emergency Evacuation and Fire Prevention

The Safety Program Administrator is responsible for ensuring the following:

1. That all required emergency exits are clearly identified in the office, shop, and warehouse and that all required fire-fighting and emergency equipment is available and in good condition.

The following items will be maintained:

- * First aid kit
 - * Drinking water
 - * Flashlight
 - * Portable battery powered radio and batteries
 - * Fire extinguishers
 - * Wrench to shut off the main gas valve
 - * Pry bars, axes, saws, tools or similar devices for employee rescue
2. Creating a facility map designating all emergency evacuation routes and the locations of all fire-fighting equipment and emergency supplies and equipment. These maps will be posted in at least two locations in the facility.
 3. Training all exposed employees on the procedures to be followed in the event of fire, earthquake or other emergency including how to properly notify other affected employees.
 4. Identifying potential fire hazards in the office, shop and warehouse and ensuring that adequate steps are taken to prevent fires.
 5. Ensuring that combustible trash and materials are removed promptly from the facility, and that all flammable and combustible liquids are properly stored and handled.

During an Emergency

In the event of an emergency such as earthquake or fire, all employees are expected to evacuate the premises immediately. The Safety Program Manager or Safety Committee members may assign some employees the task of shutting off the gas or electricity, if needed. At no time will any employee be expected to jeopardize their own safety to do this.

Employees will be notified of emergencies through one of the following:

- * Fire alarm
- * Intercom
- * Emergency horn
- * Direct voice communication

After the emergency evacuation has been completed, a head count will be taken to ensure everyone is out of the building.

If necessary, the Safety Program Administrator or Safety Committee members may assign some employees to rescue trapped employees.

Fire Prevention in Shops and Warehouses

The following procedures will be used to prevent fires in shops and warehouses.

1. All accumulated combustible trash and debris will be removed as soon as practical.
2. Flammable liquids will only be stored and dispensed from UL approved safety containers designed for that purpose.
3. All rags soaked with flammable or combustible liquids will be properly stored in closed metal containers.
4. Appropriate precautions will be taken to prevent fires when torch cutting, welding or soldering.
5. Compressed gas cylinders containing flammable or explosive gasses will be properly stored in the upright position with their caps on and protected from heat or puncture. Fuel gas and oxygen shall be separated at least 20 feet when stored.
6. Smoking or open lights are prohibited within 50 feet of flammable liquid or gas storage and dispensing areas.
7. Flammable solvents will not be used for cleaning purposes.
8. A fire extinguisher, rated not less than 2A, shall be provided for each 3,000 square feet of the floor area, or fraction thereof. Where the floor area is less than 3,000 square feet, at least one extinguisher shall be provided.
9. Travel distance from any point of the protected area to the nearest fire extinguisher shall not exceed 75 feet.
10. At least one fire extinguisher, rated not less than 2A, shall be provided on each floor. In multi-story buildings, at least one fire extinguisher shall be located adjacent to the stairway at each floor level.
11. A fire extinguisher, rated not less than 10B, shall be provided within 50 feet of wherever more than 5 gallons of flammable or combustible liquids or 5 pounds of flammable gas are being used on the job site. This requirement does not apply to the integral fuel tanks of motor vehicles.
12. Portable fire extinguishers shall be inspected monthly, or at more frequent intervals by the employer, and serviced at least annually by a person licensed or registered by the State Fire Marshal. NOTE: Inspection is a "quick check" that an extinguisher is available and will operate. It is intended to give reasonable assurance that the extinguisher is fully charged and operable. This is done by seeing that it is in its designated place, that it has not been actuated or tampered with, and that there is no obvious or physical damage or condition to prevent operation.
13. Suitable fire control devices, such as portable fire extinguishers, shall be available at locations where flammable or combustible liquids are stored.
14. At least one portable fire extinguisher, having a rating of not less than 20-B units, shall be located outside of, but not more than 10 feet from, the door opening into any room used for flammable liquid storage.
15. At least one portable fire extinguisher, having a rating of not less than 20-B units, shall be located not less than 25 feet, nor more than 75 feet, from any flammable liquid storage area located outside.

FLEET AND DRIVER SAFETY

The company has established the following guidelines and procedures for our drivers and vehicles to protect the safety of individuals operating any motor vehicle on company business. Protecting our employee drivers, their passengers, and the public is of the highest priority. The commitment of management and employees is critical to the success of this program. Clear communication of, and strict adherence to, the program's guidelines and procedures are essential.

Our primary goal is to maintain a high level of safety awareness and foster responsible driving behavior. Driver safety awareness and responsible driving behavior will significantly decrease the frequency of motor vehicle accidents and reduce the severity of personal injuries and property damage.

Drivers must follow the requirements outlined in this program. Violations of this program may result in disciplinary action up to, and including, suspension of driving privileges or dismissal.

Our program consists of the following elements:

- * Driver selection
- * Driver training
- * Vehicle use policy
- * Vehicle inspection & preventive maintenance
- * Accident investigation

Driver Selection

Only company authorized and assigned employees are allowed to drive company vehicles at any time. Prior to being authorized and assigned, the company will check the following items. Drivers must have:

- * A valid un-restricted driver license.
- * A current MVR driving record with no more than 2 points and no serious or major violations.

The company will also check driving records of all employees authorized to drive on company business on an annual basis.

Employees that do not meet these requirements are not authorized or allowed to drive company vehicles or drive their own vehicle on company business.

Driver Training

All employees driving company vehicles, and personal vehicles on company business, will be given a copy of the Driving Safety Rules and Company Vehicle Use Policy and required to read and sign for them. Safe driving will also be periodically covered at company safety meetings.

Company Vehicle Use Policy

The company has established the following policies pertaining to company vehicles:

1. Personal and off duty use of company vehicles is prohibited.

2. Only authorized employees may drive company vehicles. No other family members may drive company vehicles.
3. Non-employee passengers are not permitted in company vehicles at any time, unless they are business related.
4. Seat belts must be worn in company vehicles at all times.
5. No employee is permitted to drive company vehicles while impaired by alcohol, illegal or prescription drugs, or over the counter medications.
6. All accidents involving company vehicles must be reported to the office immediately.
7. Employees with two or more preventable accidents in a three year period, or that obtain three points on their driving record, will be subject to a loss of their driving privileges or have their driving privileges restricted.

Vehicle Inspection & Preventive Maintenance

All company vehicles must be inspected by the driver prior to each use. Mechanical defects will be repaired immediately. The Safety Program Administrator will periodically spot check company vehicles to determine their condition.

Vehicle inspections will include:

- * Lights
- * Turn signals
- * Emergency flashers
- * Tires
- * Horn
- * Brakes
- * Fluids
- * Windshield condition and wiper condition
- * Mirrors

All vehicles will also be maintained in accordance with the manufacturers' recommendations. It is the responsibility of the individual assigned the vehicle to ensure proper maintenance and repairs are performed. If your vehicle is not safe, do not drive.

Accident Investigation

All accidents in company vehicles will be investigated by the Supervisor, Manager and / or the Safety Program Administrator. Where possible, witness's statements will be obtained and photos used to document the scene of the accident and the damage. Police reports will also be obtained whenever possible. The following guidelines will be used to help determine preventability.

Auto Accident Preventability Guide

This guide will assist in determining whether our driver could have prevented the accident. An accident is preventable if the driver could have done something to avoid it. Drivers are expected to drive defensively. Which driver was primarily at fault,

which received a traffic citation, or whether a claim was paid has no bearing on preventability. If there was anything our driver could have done to avoid the collision, then the accident was preventable.

An accident was non preventable when the vehicle was legally and properly parked, or when properly stopped because of a highway patrol officer, a signal, stop sign, or traffic condition. When judging accident preventability, here are some general questions to consider:

1. Does the investigation indicate that the driver considers the rights of others, or is there evidence of poor driving habits that need to be changed?
2. Does the investigation indicate driver awareness? Such phrases as "I did not see," "I didn't think," "I didn't expect," or "I thought" are signals indicating there probably was a lack of awareness, and the accident was preventable. An aware driver should think, expect, and see hazardous situations in time to avoid collisions.
3. Was the driver under any physical stresses that could have been contributory? Did the accident happen near the end of a long day or long drive? Did overeating contribute to fatigue? Did the driver get prior sufficient sleep? Is the driver's vision faulty? Was the driver feeling ill?
4. Was the vehicle defective without the driver's knowledge? Was a pre-trip inspection done, and would it have discovered the defect? A car that pulls to the left or right when the driver applies the brakes, faulty windshield wipers, and similar items are excuses, and a driver using them is trying to evade responsibility. Sudden brake failure, loss of steering, or a blowout might be defects beyond the driver's ability to predict. However, pre-trip inspections and regularly scheduled maintenance should prevent most of these problems. If either of these are the cause of the accident, then the accident was probably preventable by the driver.
5. Could the driver have exercised better judgment by taking an alternate route through less congested areas to reduce the hazardous situations encountered?
6. Could the driver have done anything to avoid the accident?
7. Was the driver's speed safe for conditions?
8. Did the driver obey all traffic signals?
9. Was the driver's vehicle under control?

Intersection Collisions

Failure of our driver to yield the right-of-way, regardless of who has the right of way, as indicated by stop signs or lights, is preventable. The only exception to this is when the driver is properly proceeding through an intersection protected by lights or stop signs and the driver's vehicle is struck in the extreme rear side of the vehicle. Regardless of stop signs, stoplights, or right-of-way, a defensive driver recognizes that the right-of-way belongs to anyone who assumes it and should yield accordingly.

Questions to consider:

1. Did the driver approach the intersection at a speed safe for conditions?
2. Was the driver prepared to stop before entering the intersection?
3. At a blind corner, did the driver pull out slowly, ready to apply the brakes?
4. Did the driver look both ways before proceeding through the intersection?

Sideswipes

Sideswipes are often preventable. Defensive drivers do not get into a position where they can be forced into another vehicle or another vehicle can be forced into them. Defensive drivers continuously check for escape routes to avoid sideswipes. For two lane roads, this means a driver should pass another vehicle only when absolutely certain that he or she can safely complete the pass. A driver should also be ready to slow down and let a passing vehicle that has failed to judge safe passing distance back into the lane. A driver should make no sudden moves that may force another vehicle to swerve. If a driver sideswipes a stationary object while taking evasive action to avoid striking another car or a pedestrian, such an accident may not be preventable. However, you should consider what the driver could have done or failed to do immediately preceding the evasive action to be in the position of no other options.

A driver is also expected to anticipate the actions of an oncoming vehicle. Sideswiping an oncoming vehicle is often preventable. Again, evasive action, including leaving the roadway, may be necessary if an oncoming vehicle crosses into the driver's lane. Drivers are expected to allow merging vehicles to merge smoothly with them, and to merge smoothly on controlled access highways. Drivers are expected to be able to gauge distances properly when leaving a parking place and enter traffic smoothly.

Questions to consider:

1. Did the driver look to front and rear for approaching and overtaking traffic immediately before starting to pull away from the curb?
2. Did the driver signal before pulling away from the curb?
3. Did the driver look back rather than depend only upon rear-view mirrors?
4. Did the driver start into traffic only when this action would not require traffic to change its speed or direction in order to avoid his or her vehicle?

Head-on Collisions

A head-on collision with a vehicle traveling in the wrong lane may be preventable if the driver could have pulled off the road or taken other evasive action to prevent a collision. However, the driver should never drive into the other lane to avoid the oncoming vehicle. If the driver swerved off the road to avoid a head-on collision, the accident is non-preventable. The driver in this case made a good defensive driving decision, taking the lesser of two evils.

Many skidding conditions are caused by rain, freezing rain, fog, and snow, which all increase the hazard of travel. Oily road film, which builds up during a period of good weather, causes an especially treacherous condition during the first minutes of a rainfall. Loss of traction can be anticipated, and these accidents usually are preventable. Driving too fast for conditions is the most common reason why these types of accidents are preventable.

Questions to consider:

1. Was the driver operating at a safe speed considering weather and road conditions?
2. During inclement weather, was the driver keeping at least twice the safe following distance used for dry pavement?
3. Were all actions gradual?
4. Was the driver anticipating ice on bridges, in gutter, ruts, and near the curb?
5. Was the driver alert for water, ice or snow in shaded areas, loose gravel, sand, ruts, etc?

If a driver goes off the road or strikes another vehicle because of skidding, the accident is preventable.

Pedestrian Accidents

All types of pedestrian accidents, including collisions with pedestrians coming from between parked cars, are usually

considered preventable. There are few instances where the action of pedestrians is so unreasonable that the operator could not be expected to anticipate such an occurrence.

Questions to consider:

1. Did the driver go through congested areas expecting that pedestrians would step in front of the vehicle?
2. Was the driver prepared to stop?
3. Did the driver keep as much clearance between his or her vehicle and parked vehicles, as safety permitted?
4. Did the driver stop when other vehicles had stopped to allow pedestrians to cross?
5. Did the driver wait for the green light or stop for the caution light?
6. Was the driver aware of children and prepared to stop if one ran into the street?
7. Did the driver give all pedestrians the right-of-way?
8. Did the driver stop for a school bus that was stopped and properly signaling that passengers were loading or unloading?

Backing Accidents

Backing a vehicle into another vehicle, an overhead obstruction, or a stationary object is normally preventable. The fact that someone was directing the driver in backing does not relieve the driver of the responsibility to back safely.

Questions to consider:

1. Was it necessary to back?
2. Did the driver plan ahead so that he or she could have pulled forward out of the parking space instead of backing?
3. Was it necessary to drive into the narrow street, dead-end alley, or driveway from which he or she backed?
4. If the driver could not see where he or she was backing: Did the driver try to get someone to guide him or her?
5. Did the driver look all around the vehicle before backing? Did the driver back immediately after looking?
6. Did the driver use the horn while backing? Were the back-up lights working?
7. Did the driver look to the rear without relying totally on the rear-view mirror?
8. If the distance was long, did the driver stop, get out, and look around occasionally?
9. Did the driver back slowly?
10. Did the driver judge clearances accurately?

Parking Accidents

Doors on our driver's parked vehicle that are damaged when opened on the traffic side are considered preventable accidents. The driver is responsible to see that the traffic side is clear of traffic, before any doors on that side are opened.

In most cases, if our driver, while driving, strikes a parked vehicle's opening door it is considered preventable. Usually our driver can see from a sufficient distance that the parked vehicle is occupied, and should therefore, be prepared to stop, should move closer to the center line or change lanes.

It is a driver's responsibility to park the vehicle so that it will remain stationary. A runaway type accident is preventable and blaming such a collision on defective parking brakes or other holding devices are inadequate excuses. A good pre-trip inspection and maintenance program will eliminate most opportunities for this type of accident being the result of mechanical failure.

Accidents occurring when vehicles are properly and legally parked are considered non preventable. Accidents occurring while the vehicle was double-parked or in a "No Parking" zone are preventable.

Questions to consider:

1. Was the vehicle parked on the proper side of the road?
2. Was it necessary to park there or was there a safer, only slightly less convenient place nearby?
3. Did the driver have to park on the traveled part of the highway, on the curve, or on the hill?
4. When required, did the driver warn traffic by emergency warning devices?
5. Did the driver park parallel to the curb?
6. Was it necessary to park so close to an alley or directly across from a driveway?

Collision with Obstructions

Obstructions can be avoided if the driver knows the height and width of the vehicle, pays attention to posted clearances, and takes the time to properly judge clearances.

Cargo Accidents

The accident should be considered preventable if the investigation shows a mechanical defect of which the driver was aware, a defect the driver should have found by inspecting the vehicle, or the driver caused the accident by rough and abusive handling. It is a driver's responsibility to secure cargo properly to prevent shifting, loss, or damage. Cargo should be safely stowed to prevent flying objects that can strike or distract the driver.

FALL PROTECTION

The company has the following requirements for fall protection at all of our worksites.

Fall Protection is Required

When working where there is a hazard of falling more than 6 feet from the perimeter of a structure, unprotected sides and edges, leading edges, through shaft ways and openings, sloped roof surfaces steeper than 7:12, or other sloped surfaces steeper than 40 degrees not otherwise adequately protected. Fall protection is also required when working in boom lifts.

Fall Protection Types

One of the following four types of fall protection systems will be used when our employees are exposed to fall hazards in excess of 6 feet:

1. Standard guardrails, cables or floor hole covers
2. Personal fall arrest system
3. Positioning devices
4. Fall restraint systems

Standard Guardrails, Safety Cables, or Covers

These are the easiest and most cost effective methods of providing fall protection and have a very high success rate. Standard guardrails, safety cables, floor hole and sky light covers are our preferred means of fall protection on job sites. The following rules will be followed when using them:

1. Railings shall be constructed of wood, or in an equally substantial manner from other materials, and shall consist of a top rail not less than 42 inches or more than 45 inches in height measured from the upper surface of the top rail to the floor, platform, runway or ramp level and a mid-rail. The mid rail shall be halfway between the top rail and the floor, platform, runway or ramp. "Selected lumber" free from damage that affects its strength, shall be used.
2. Wooden posts shall be not less than 2 inches by 4 inches in cross section, spaced at 8-foot or closer intervals.
3. Wooden top railings shall be smooth and of 2-inch by 4-inch or larger material. Double, 1-inch by 4-inch members may be used for this purpose, provided that one member is fastened in a flat position on top of the posts and the other fastened in an edge-up position to the inside of the posts and the side of the top member. Mid rails shall be of at least 1-inch by 6-inch material.
4. The rails shall be placed on the side of the post that will afford the greatest support and protection.
5. All guardrails, including their connections and anchorage, shall be capable of withstanding a load of 13 pounds per linear foot applied either horizontally or vertically downward at the top rail.
6. Railings receiving heavy stresses from employees trucking or handling materials shall be provided additional strength by the use of heavier stock, closer spacing of posts, bracing, or by other means.
7. Floor, roof and skylight openings shall be guarded by a standard railing and toe boards or cover. Covering shall be capable

of safely supporting the greater of the weight of a 200-pound person or the weight of worker(s) and material(s) placed thereon.

8. Coverings shall be secured in place to prevent accidental removal or displacement, and shall bear a pressure sensitized, painted, or stenciled sign with legible letters not less than one inch high, stating: "Opening--Do Not Remove." Markings of chalk or keel shall not be used.
9. Ladder way floor openings or platforms shall be guarded by standard railings with standard toe boards on all exposed sides, except at the entrance to the opening, with the passage through the railing either provided with a swinging gate or so offset that a person cannot walk directly into the opening.
10. Floor holes, into which persons can accidentally walk, shall be guarded by either a standard railing with standard toe boards on all exposed sides, or a floor hole cover of standard strength and construction that is secured against accidental displacement. While the cover is not in place, the floor hole shall be protected by standard railings.
11. Wall openings, from which there is a drop of more than 4 feet, and the bottom of the opening is less than 3 feet above the working surface, shall be guarded with either a standard rail or intermediate rail or both.
12. An extension platform outside a wall opening onto which materials can be hoisted for handling shall have side rails or equivalent guards of standard specifications. One side of an extension platform may have removable railings in order to facilitate handling materials.
13. Wall opening protection barriers shall be of such construction and mounting that, when in place at the opening, the barrier is capable of withstanding a load of at least 200 pounds applied in any direction (except upward).
14. All elevator shafts in which cages are not installed and which are not enclosed with solid partitions and doors shall be guarded on all open sides by standard railings and toe boards.
15. A full body harness and lanyard are required when using boom lifts.

Personal Fall Arrest Systems

Personal fall arrest systems consist of a full body harness and a shock-absorbing lanyard attached to suitable anchorage. They are also an effective means of preventing fall accidents. The system does not actually stop you from falling, but catches you and safely stops you from hitting the level below. Fall arrest systems will be our preferred means of protection when standard guardrails, safety cables, or covers are not practical. The following rules, in addition to the manufacturer's requirements and OSHA regulations, will be observed:

1. Ropes and straps (webbing) used in lanyards, lifelines, and strength components of body harnesses shall be made from synthetic fibers except when they are used in conjunction with hot work where the lanyard may be exposed to damage from heat or flame.
2. Anchorages used for attachment of personal fall arrest equipment shall be independent of any anchorage being used to support or suspend platforms and capable of supporting at least 5,000 pounds per employee attached, or shall be designed, installed, and used as part of a complete personal fall arrest system which maintains a safety factor of at least two; and under the supervision of a qualified person.
3. The attachment point of the body belt shall be located in the center of the wearer's back. The attachment point of the body harness shall be located in the center of the wearer's back near shoulder level, or above the wearer's head.
4. Where practical, the anchor end of the lanyard shall be secured at a level not lower than the employee's waist, limiting

the fall distance to a maximum of 4 feet.

5. Harnesses, lanyards, and other components shall be used only for employee protection as part of a personal fall arrest system and not to hoist materials.
6. Personal fall arrest systems and components subjected to impact loading shall be immediately removed from service and shall not be used again for employee protection until inspected and determined by a competent person to be undamaged and suitable for reuse.
7. The company shall provide for prompt rescue of employees in the event of a fall or shall assure that employees are able to rescue themselves.
8. Personal fall arrest systems shall be inspected prior to each use for wear, damage and other deterioration, and defective components shall be removed from service.
9. Any lanyard, safety harness, or drop line subjected to in-service loading, as distinguished from static load testing, shall be immediately removed from service and shall not be used again for employee safeguarding.
10. Personal fall arrest systems shall not be attached to guardrails, unless the guardrail is capable of safely supporting the load.
11. Each personal fall arrest system shall be inspected not less than twice annually by a competent person in accordance with the manufacturer's recommendations. The date of each inspection shall be documented.
12. Personal fall arrest systems will be rigged such that an employee can neither free fall more than 4 feet, nor contact any lower level.
13. Personal fall arrest systems will bring an employee to a complete stop. They will also limit maximum deceleration distance an employee travels to 3.5 feet and have sufficient strength to withstand twice the potential impact energy of an employee free falling a distance of 6 feet, or the free fall distance permitted by the system, whichever is less.

Positioning Device Systems

Positioning device systems are designed to allow employees to work with both hands free at elevated locations. By their very nature, they provide some level of fall protection. They are not as effective as railings or fall arrest systems. Positioning device systems may be used together with a fall arrest system for greater safety. Their use shall conform to the following provisions:

1. Positioning devices shall be rigged such that an employee cannot free fall more than 2 feet.
2. Positioning device systems shall be inspected prior to each use for wear, damage, and other deterioration and defective components shall be removed from service.
3. Body belts, harnesses, and components shall be used only for employee protection (as part of a personal fall arrest system or positioning device system) and not to hoist materials.
4. The use of non-locking snap hooks is prohibited.
5. Anchorage points for positioning device systems shall be capable of supporting two times the intended load or 3,000 pounds, whichever is greater.

Personal Fall Restraint

Fall restraint systems are designed to prevent the wearer from reaching the edge or danger area and thus prevent them from falling. Body belts or harnesses may be used for personal fall restraint.

1. Body belts shall be at least one and five-eighths (1 5/8) inches wide.
2. Anchorage points used for fall restraint shall be capable of supporting 4 times the intended load.
3. Restraint protection shall be rigged to allow the movement of employees only as far as the sides of the working level or working area.

RESPIRATORY PROTECTION

Occasionally our work may necessitate the use of respirators to protect against air contaminants. Due to the limitations of respirators and their uncomfortable nature, the company will make every effort to provide other means of protection, such as local exhaust ventilation, or substitution of less hazardous material, prior to requiring employees to wear them.

When it is clearly impractical to remove harmful dusts, fumes, mists, vapors, or gases at their source, or where emergency protection against occasional and/or relatively brief exposure is needed, the company will provide, and the employee exposed to such hazard shall use, approved respiratory equipment.

Whenever respirators are required to be used to control harmful exposures, only respiratory equipment approved for that purpose shall be used and such equipment shall be approved by the National Institute for Occupational Safety and Health (NIOSH). Only parts approved for the specific respirator system shall be used for replacement.

General Respiratory Protection Guidelines:

1. Atmospheric contamination will be prevented wherever feasible through engineering controls such as enclosure or confinement of the operation, general and local exhaust ventilation, or substitution of less toxic materials. When effective engineering controls are not feasible, or while they are being instituted, appropriate respirators shall be used.
2. The company shall identify and evaluate the respiratory hazard(s) in the workplace; this evaluation shall include a reasonable estimate of employee exposures to respiratory hazard(s) and an identification of the contaminant's chemical state and physical form. Where we cannot identify or reasonably estimate the employee exposure, the atmosphere shall be considered to be immediately dangerous to life or health (IDLH).
3. Respirators shall be provided when such equipment is necessary to protect the health of the employee.
4. Only NIOSH-certified respirators shall be used. The respirator shall be used in compliance with the conditions of its certification.
5. The company will provide respirators that are applicable and suitable for the purpose intended. We shall select and provide an appropriate respirator based on the respiratory hazard(s) to which the worker is exposed and workplace and user factors that affect respirator performance and reliability.
6. Respirators shall be selected from a sufficient number of respirator models and sizes so that the respirator is acceptable to, and correctly fits, the user.
7. The safety program administrator is qualified by appropriate training or experience that is commensurate with the complexity of the program to administer or oversee the respiratory protection program and conduct the required evaluations of program effectiveness.
8. The company will provide respirators, training, and medical evaluations at no cost to the employee.
9. The company will provide a medical evaluation to determine the employee's ability to use a respirator, before the employee is fit tested or required to use the respirator in the workplace. We may discontinue an employee's medical evaluations when the employee is no longer required to use a respirator.
10. The company will ensure that employees using a tight-fitting face piece respirator pass an appropriate qualitative fit test (QLFT) or quantitative fit test (QNFT).

11. The company will establish and implement procedures for the proper use of respirators. These requirements include prohibiting conditions that may result in face piece seal leakage, preventing employees from removing respirators in hazardous environments, taking actions to ensure continued effective respirator operation throughout the work shift, and establishing procedures for the use of respirators in IDLH atmospheres.
12. We shall provide each respirator user with a respirator that is clean, sanitary, and in good working order. The Supervisor or Manager shall ensure that respirators are cleaned and disinfected.
13. All filters, cartridges and canisters used in the workplace must be legibly labeled and color-coded with the NIOSH approval label that must not be removed.
14. Training and information will be provided to employees who are required to use respirators. The training will be comprehensive, understandable, and recur annually, or more often if necessary.
15. The safety program administrator shall conduct evaluations of the workplace to ensure that the written respiratory protection program is being properly implemented, and to consult with employees to ensure that they are using the respirators properly.
16. Written information regarding medical evaluations, fit testing, and the respirator program shall be retained indefinitely. This information will facilitate employee involvement in the respirator program, assist us in auditing the adequacy of the program, and provide a record for compliance determinations by OSHA.
17. Where respirator use is not required by a particular standard or hazard, the company may provide respirators at the request of employees or permit employees to use their own respirators, if we determine that such respirator use will not in itself create a hazard. If voluntary respirator use is permissible, we shall provide the respirator users with the information contained in Appendix D of section 5144 8CCR. ("Information for Employees Using Respirators When Not Required Under the Standard.")

Respirator Selection Requirements

The proper respirator for the job and hazard shall be selected. This selection will be made in accordance with ANSI Z88.2-1980 standards. The correct respirator shall be specified for each job. The individual issuing them shall be adequately instructed to insure that the correct respirator is used.

The manufacturers' recommendations and literature will also be reviewed to determine if the respirator provides protection against the expected contaminants. For instance, dust masks do not provide protection against gasses or vapors.

The safety program administrator or another qualified individual shall review and approve all breathing air compressors and installations for compliance with appropriate OSHA regulations and safety procedures prior to use.

Respirators for IDLH atmospheres.

We shall provide the following respirators for employee use in IDLH atmospheres:

- A full face piece pressure demand SCBA certified by NIOSH for a minimum service life of thirty minutes, or
- A combination full face piece pressure demand supplied-air respirator (SAR) with auxiliary self-contained air supply.
- Respirators provided only for escape from IDLH atmospheres shall be NIOSH-certified for escape from the atmosphere in which they will be used.
- All oxygen-deficient atmospheres shall be considered IDLH.

Respirators for atmospheres that are not IDLH.

The company shall provide a respirator that is adequate to protect the health of the employee and ensure compliance with all other OSHA statutory and regulatory requirements, under routine and reasonably foreseeable emergency situations. The respirator selected shall be appropriate for the chemical state and physical form of the contaminant.

For protection against gases and vapors:

- An atmosphere-supplying respirator, or
- An air-purifying respirator, provided that the respirator is equipped with an end-of-service-life indicator (ESLI) certified by NIOSH for the contaminant; or if there is no ESLI appropriate for conditions in the workplace, we will implement a change schedule for canisters and cartridges that is based on objective information or data that will ensure that canisters and cartridges are changed before the end of their service life.

For protection against particulates:

- An atmosphere-supplying respirator; or
- An air-purifying respirator equipped with a filter certified by NIOSH under 30 CFR part 11 as a high efficiency particulate air (HEPA) filter, or an air-purifying respirator equipped with a filter certified for particulates by NIOSH under 42 CFR part 84; or
- For contaminants consisting primarily of particles with mass median aerodynamic diameters (MMAD) of at least 2 micrometers, an air-purifying respirator equipped with any filter certified for particulates by NIOSH.

Medical Evaluation Procedures

1. Employees shall not be assigned to tasks requiring the use of respirators unless it has been determined that they are physically able to perform the work while using the required respiratory equipment.
2. The company shall identify a physician or other licensed health care professional (PLHCP) to perform medical evaluations.
3. The medical evaluation shall include any medical tests, consultations, or diagnostic procedures that the PLHCP deems necessary to make a final determination.
4. Medical questionnaires and examinations shall be administered confidentially during the employee's normal working hours or at a time and place convenient to the employee.
5. The employee shall have an opportunity to discuss the examination results with the PLHCP.
6. The following information must be provided to the PLHCP before the PLHCP makes a recommendation concerning an employee's ability to use a respirator:
 - The type and weight of the respirator to be used by the employee;
 - The duration and frequency of respirator use (including use for rescue and escape);
 - The expected physical work effort;
 - Additional protective clothing and equipment to be worn; and
 - Temperature and humidity extremes that may be encountered.

7. The company shall provide the PLHCP with a copy of this written respiratory protection program and a copy of the OSHA regulations if they do not already have them.
8. In determining the employee's ability to use a respirator, the company shall obtain a written recommendation regarding the employee's ability to use the respirator from the PLHCP. The recommendation shall provide only the following information:
 - Any limitations on respirator use related to the medical condition of the employee, or relating to the workplace conditions in which the respirator will be used, including whether or not the employee is medically able to use the respirator;
 - The need, if any, for follow-up medical evaluations; and
 - A statement that the PLHCP has provided the employee with a copy of the PLHCP's written recommendation.
9. If the respirator is a negative pressure respirator and the PLHCP finds a medical condition that may place the employee's health at increased risk if the respirator is used, the company shall provide a powered air purifying respirator (PAPR) if the PLHCP's medical evaluation finds that the employee can use such a respirator; if a subsequent medical evaluation finds that the employee is medically able to use a negative pressure respirator, then we are no longer required to provide a PAPR.
10. The company shall provide additional medical evaluations that comply with the requirements of this section if:
 - An employee reports medical signs or symptoms that are related to ability to use a respirator;
 - A PLHCP, supervisor, or the respirator program administrator informs the employer that an employee needs to be reevaluated;
 - Information from the respiratory protection program, including observations made during fit testing and program evaluation, indicates a need for employee reevaluation; or
 - A change occurs in workplace conditions (e.g., physical work effort, protective clothing, temperature) that may result in a substantial increase in the physiological burden placed on an employee.

Fit Testing

1. The company shall ensure that an employee using a tight-fitting face piece respirator is fit tested prior to initial use of the respirator, whenever a different respirator face piece (size, style, model or make) is used, and at least annually thereafter.
2. We shall conduct an additional fit test whenever the employee reports, or the employer, PLHCP, supervisor, or program administrator makes visual observations of, changes in the employee's physical condition that could affect respirator fit. Such conditions include, but are not limited to, facial scarring, dental changes, cosmetic surgery, or an obvious change in body weight.
3. If after passing a QLFT or QNFT, the employee subsequently notifies the program administrator, supervisor, or PLHCP that the fit of the respirator is unacceptable, the employee shall be given a reasonable opportunity to select a different respirator face piece and to be retested.
4. The fit test shall be administered using an OSHA-accepted QLFT or QNFT protocol.

Usage Rules

1. The company shall not permit respirators with tight-fitting face pieces to be worn by employees who have:
 - Facial hair that comes between the sealing surface of the face piece and the face or that interferes with valve function; or
 - Any condition that interferes with the face-to-face piece seal or valve function.
2. If an employee wears corrective glasses or goggles or other personal protective equipment, we shall ensure that such equipment is worn in a manner that does not interfere with the seal of the face piece to the face of the user.
3. For all tight-fitting respirators, we shall ensure that employees perform a user seal check each time they put on the respirator.
4. Appropriate surveillance shall be maintained of work area conditions and degree of employee exposure or stress. When there is a change in work area conditions or degree of employee exposure or stress that may affect respirator effectiveness, we shall reevaluate the continued effectiveness of the respirator.
5. Respiratory equipment shall not be passed on from one person to another until it has been cleaned and sanitized. Respirators individually assigned should be marked to indicate to whom it was assigned. This mark shall not affect the respirator performance in any way. The date of issuance should be recorded.
6. When not in use, respirators shall be stored to protect against dust, sunlight, extreme temperatures, excessive moisture, or damaging chemicals. Plastic zip lock bags are suitable for storage.
7. The company shall ensure that employees leave the respirator use area:
 - To wash their faces and respirator face pieces as necessary to prevent eye or skin irritation associated with respirator use; or
 - If they detect vapor or gas breakthrough, changes in breathing resistance, or leakage of the face piece; or
 - To replace the respirator or the filter, cartridge, or canister elements.
8. If the employee detects vapor or gas breakthrough, changes in breathing resistance, or leakage of the face piece, we will replace or repair the respirator before allowing the employee to return to the work area.
9. For all IDLH atmospheres, the company shall ensure that:
 - One employee or, when needed, more than one employee is located outside the IDLH atmosphere;
 - Visual, voice, or signal line communication is maintained between the employee(s) in the IDLH atmosphere and the employee(s) located outside the IDLH atmosphere;
 - The employee(s) located outside the IDLH atmosphere are trained and equipped to provide effective emergency rescue;
 - The Supervisor or designee is notified before the employee(s) located outside the IDLH atmosphere enter the IDLH atmosphere to provide emergency rescue;
 - The Supervisor or designee authorized to do so by «Company_Name», once notified, provides necessary assistance appropriate to the situation;
 - Employee(s) located outside the IDLH atmospheres are equipped with pressure demand or other positive pressure SCBAs, or a pressure demand or other positive pressure supplied-air respirator with auxiliary SCBA; and either appropriate retrieval equipment for removing the employee(s) who enter(s) these hazardous atmospheres where retrieval equipment would contribute to the rescue of the employee(s) and would not increase the overall risk resulting from entry; or equivalent means for rescue where retrieval equipment is not required.

Maintenance, Inspection and Care of Respirators

1. The company shall ensure that respirators are cleaned and disinfected using procedures recommended by the respirator manufacturer, provided that such procedures are of equivalent effectiveness to OSHA regulations. The respirators shall be cleaned and disinfected at the following intervals:
 - Respirators issued for the exclusive use of an employee shall be cleaned and disinfected as often as necessary to be maintained in a sanitary condition;
 - Respirators issued to more than one employee shall be cleaned and disinfected before being worn by different individuals;
 - Respirators maintained for emergency use shall be cleaned and disinfected after each use; and
 - Respirators used in fit testing and training shall be cleaned and disinfected after each use.
2. All respirators shall be stored to protect them from damage, contamination, dust, sunlight, extreme temperatures, excessive moisture, and damaging chemicals, and they shall be packed or stored to prevent deformation of the face piece and exhalation valve.
3. Emergency respirators shall be:
 - Kept accessible to the work area;
 - Stored in compartments or in covers that are clearly marked as containing emergency respirators; and
 - Stored in accordance with any applicable manufacturer instructions.
4. All respirators used in routine situations shall be inspected before each use and during cleaning;
5. All respirators maintained for use in emergency situations shall be inspected at least monthly and in accordance with the manufacturer's recommendations, and shall be checked for proper function before and after each use; and
6. Emergency escape-only respirators shall be inspected before being carried into the workplace for use.
7. The company shall ensure that respirator inspections include the following:
 - A check of respirator function, tightness of connections, and the condition of the various parts including, but not limited to, the face piece, head straps, valves, connecting tube, and cartridges, canisters or filters; and
 - A check of elastomeric parts for pliability and signs of deterioration.
8. In addition to the requirements above, self-contained breathing apparatus shall be inspected monthly.
9. Air and oxygen cylinders shall be maintained in a fully charged state and shall be recharged when the pressure falls to 90% of the manufacturer's recommended pressure level. The employer shall determine that the regulator and warning devices function properly.
10. For respirators maintained for emergency use, the company shall:
 - Certify the respirator by documenting the date the inspection was performed, the name (or signature) of the person who made the inspection, the findings, required remedial action, and a serial number or other means of identifying the inspected respirator; and
 - Provide this information on a tag or label that is attached to the storage compartment for the respirator, is kept with the respirator, or is included in inspection reports stored as paper or electronic files. This information shall be maintained until replaced following a subsequent certification.

11. Repairs. The company shall ensure that respirators that fail an inspection or are otherwise found to be defective are removed from service, and are discarded or repaired or adjusted in accordance with the following procedures:
 - Repairs or adjustments to respirators are to be made only by persons appropriately trained to perform such operations and shall use only the respirator manufacturer's NIOSH-approved parts designed for the respirator;
 - Repairs shall be made according to the manufacturer's recommendations and specifications for the type and extent of repairs to be performed; and
 - Reducing and admission valves, regulators, and alarms shall be adjusted or repaired only by the manufacturer or a technician trained by the manufacturer.

Training

1. The company shall ensure that each employee required to use a respirator can demonstrate knowledge of at least the following:
 - Why the respirator is necessary and how improper fit, usage, or maintenance can compromise the protective effect of the respirator;
 - What the limitations and capabilities of the respirator are;
 - How to use the respirator effectively in emergency situations, including situations in which the respirator malfunctions;
 - How to inspect, put on and remove, use, and check the seals of the respirator;
 - What the procedures are for maintenance and storage of the respirator;
 - How to recognize medical signs and symptoms that may limit or prevent the effective use of respirators; and
2. The training shall be conducted in a manner that is understandable to the employee.
3. The training shall be provided prior to requiring the employee to use a respirator in the workplace.
4. Retraining shall be administered annually, and when the following situations occur:
 - Changes in the workplace or the type of respirator render previous training obsolete;
 - Inadequacies in the employee's knowledge or use of the respirator indicate that the employee has not retained the requisite understanding or skill; or
 - Any other situation arises in which retraining appears necessary to ensure safe respirator use.

Program Evaluation

1. The safety program administrator shall conduct evaluations of the workplace as necessary to ensure that the provisions of the current written program are being effectively implemented and that it continues to be effective.
2. The safety program administrator shall regularly consult employees required to use respirators to assess the employees' views on program effectiveness and to identify any problems. Any problems that are identified during this assessment shall be corrected. Factors to be assessed include, but are not limited to:
 - Respirator fit (including the ability to use the respirator without interfering with effective workplace performance);
 - Appropriate respirator selection for the hazards to which the employee is exposed;
 - Proper respirator use under the workplace conditions the employee encounters; and

- Proper respirator maintenance.

Recordkeeping

1. Records of medical evaluations must be retained and made available to regulatory agencies.
2. The company shall establish a record of the qualitative and quantitative fit tests administered to an employee including:
 - The name or identification of the employee tested;
 - Type of fit test performed;
 - Specific make, model, style, and size of respirator tested;
 - Date of test; and
 - The pass/fail results for QLFTs or the fit factor and strip chart recording or other recording of the test results for QNFTs.
 - Fit test records shall be retained for respirator users until the next fit test is administered.
3. Program records shall be made available upon request to affected employees and to governing or regulatory agencies for examination and copying.

Procedures for Cleaning Respirators

1. Remove filters, cartridges, or canisters. Disassemble face pieces by removing speaking diaphragms, demand and pressure-demand valve assemblies, hoses, or any components recommended by the manufacturer. Discard and replace any defective parts.
2. Wash components in warm (43 deg. C [110 deg. F] maximum) water with a mild detergent or with a cleaner recommended by the manufacturer. A stiff bristle (not wire) brush may be used to facilitate the removal of dirt.
3. Rinse components thoroughly in clean, warm (43 deg. C [110 deg. F] maximum), preferably running water. Drain.
4. When the cleaner used does not contain a disinfecting agent, respirator components should be immersed for two minutes in one of the following:
 - Hypochlorite solution (50 ppm of chlorine) made by adding approximately one milliliter of laundry bleach to one liter of water at 43 deg. C (110 deg. F); or,
 - Aqueous solution of iodine (50 ppm iodine) made by adding approximately 0.8 milliliters of tincture of iodine (6-8 grams ammonium and/or potassium iodide/100 cc of 45% alcohol) to one liter of water at 43 deg. C (110 deg. F); or,
 - Other commercially available cleansers of equivalent disinfectant quality when used as directed, if their use is recommended or approved by the respirator manufacturer.

5. Rinse components thoroughly in clean, warm (43 deg. C [110 deg. F] maximum), preferably running water. Drain. The importance of thorough rinsing cannot be overemphasized. Detergents or disinfectants that dry on face pieces may result in dermatitis. In addition, some disinfectants may cause deterioration of rubber or corrosion of metal parts if not completely removed.
6. Components should be hand-dried with a clean lint-free cloth or air-dried.
7. Reassemble face piece, replacing filters, cartridges, and canisters where necessary.
8. Test the respirator to ensure that all components work properly.

Mandatory Information for Employees Using Respirators When Not Required

Respirators are an effective method of protection against designated hazards when properly selected and worn. Respirator use is encouraged, even when exposures are below the exposure limit, to provide an additional level of comfort and protection for workers. However, if a respirator is used improperly or not kept clean, the respirator itself can become a hazard to the worker. Sometimes, workers may wear respirators to avoid exposures to hazards, even if the amount of hazardous substance does not exceed the limits set by OSHA standards. If your employer provides respirators for your voluntary use, or if you provide your own respirator, you need to take certain precautions to be sure that the respirator itself does not present a hazard.

You should do the following:

1. Read and heed all instructions provided by the manufacturer on use, maintenance, cleaning and care, and warnings regarding the respirators limitations.
2. Choose respirators certified for use to protect against the contaminant of concern. NIOSH, the National Institute for Occupational Safety and Health of the U.S. Department of Health and Human Services, certifies respirators. A label or statement of certification should appear on the respirator or respirator packaging. It will tell you what the respirator is designed for and how much it will protect you.
3. Do not wear your respirator into atmospheres containing contaminants for which your respirator is not designed to protect against. For example, a respirator designed to filter dust particles will not protect you against gases, vapors,

or very small solid particles of fumes or smoke.

4. Keep track of your respirator so that you do not mistakenly use someone else's respirator.

ELECTRICAL & LOCK-OUT / TAG-OUT PROGRAM

The company has developed the following procedures to protect our employees and reduce the risk of accidents. We will also conduct a periodic review of electrical safety, energy control procedures, and lock-out / tag-out, at least annually, to ensure that the procedure and the requirements of this section are being followed.

This procedure is binding upon all employees. All employees will be instructed in the significance of electrical safety, energy control procedures, and lock-out / tag-out. Each new employee shall be instructed by their Supervisor in the purpose and use of these procedures.

All Equipment and Installations

1. Only trained, qualified, and authorized employees will be allowed to make electrical repairs or work on electrical equipment or installations.
2. All electrical equipment and systems shall be treated as energized until tested or otherwise proven to be de-energized.
3. All energized equipment and installations will be de-energized prior to the commencement of any work. If the equipment or installation must be energized for test or other purposes, special precautions will be taken to protect against the hazards of electric shock.
4. All equipment shall be locked out to protect against accidental or inadvertent operation when such operation could cause injury to personnel. Do not attempt to operate any switch, valve, or other energy-isolating device bearing a lock.
5. Safety grounds shall always be used where there is a danger of shock from back feeding or other hazards.
6. Polyester clothing or other flammable types of clothing shall not be worn near electrical circuits. Cotton clothing is much less likely to ignite from arc blast. Employees working on live circuits shall be provided Nomex or equivalent fire resistant clothing.
7. Suitable eye protection must be worn at all times while working on electrical equipment.
8. Always exercise caution when energizing electrical equipment or installations. Take steps to protect employees from arc blast and exploding equipment in the event of a fault.
9. All power tools will be grounded or double insulated. Tools with defective cords or wiring shall not be used.
10. Suitable temporary barriers or barricades shall be installed when access to open enclosures containing exposed energized equipment is not under the control of an authorized person.

Energized Equipment or Systems

Work shall not be performed on exposed energized parts of equipment or systems until the following conditions are met:

1. Responsible supervision has determined that the work is to be performed while the equipment or systems are energized.
2. Involved personnel have received instructions on the work techniques and hazards involved in working on energized equipment and appropriate equipment to perform the job has been provided.

3. Suitable personal protective equipment has been provided and is used. Suitable insulated gloves shall be worn for voltages in excess of 300 volts, nominal.
4. Suitable eye protection, including face shield and safety glasses or goggles, has been provided and is used.
5. Fire resistant clothing such as Nomex suits is worn.
6. Where required, suitable barriers, barricades, tags, or signs are in place for personnel protection.

After the required work on an energized system or equipment has been completed, an authorized person shall be responsible for:

1. Removing from the work area any personnel and protective equipment.
2. Reinstalling all permanent barriers or covers.

De-energized Equipment or Systems

A qualified person shall be responsible for completing the following before working on de-energized electrical equipment or systems, unless the equipment is physically removed from the wiring system:

1. Notifying all involved personnel.
2. Locking the disconnecting means in the "open" position with the use of lockable devices, such as padlocks, combination locks or disconnecting of the conductor(s) or other positive methods or procedures which will effectively prevent unexpected or inadvertent energizing of a designated circuit, equipment or appliance.
3. Tagging the disconnecting means with suitable accident prevention tags.
4. Effectively blocking the operation or dissipating the energy of all stored energy devices which present a hazard, such as capacitors or pneumatic, spring-loaded and like mechanisms. This may require the installation of safety grounds.
5. Testing the equipment to ensure it is de-energized.

Energizing (or Re-energizing) Equipment or Systems

A qualified and authorized person shall be responsible for completing the following before energizing equipment or systems that have been de-energized:

1. Determining that all persons are clear from hazards which might result from the equipment or systems being energized including arc blast or explosions caused by unexpected faults.
2. Removing locking devices and tags. Only the employee who placed them may remove locking devices and tags. Locking devices and tags shall be removed upon completion of the work and after the installation of the protective guards and/or safety interlock systems.

Accident Prevention Tags

Suitable accident prevention tags shall be used to control a specific hazard. Such tags shall provide the following minimum information:

1. Reason for placing tag.
2. Name of person placing the tag and how that person may be contacted.
3. Date tag was placed.

Lock-out / Tag-out

Machinery or equipment capable of movement shall be stopped and the power source de-energized or disengaged, and locked out. If necessary, the moveable parts shall be mechanically blocked or secured to prevent inadvertent movement during cleaning, servicing or adjusting operations unless the machinery or equipment must be capable of movement during this period in order to perform the specific task. If so, the hazard of movement shall be minimized.

Equipment or power driven machines equipped with lockable controls, or readily adaptable to lockable controls, shall be locked out or positively sealed in the "off" position during repair work and setting-up operations. In all cases, accident prevention signs and/or tags shall be placed on the controls of the equipment or machines during repair work.

The company will provide a sufficient number of accident prevention signs or tags and padlocks, seals or other similarly effective means that may be required by any reasonably foreseeable repair.

Sequence of Lockout Procedure

1. Notify all affected employees that a lockout is required and the reason therefore.
2. If the equipment is operating, shut it down by the normal stopping procedure (such as: depress stop button, open toggle switch).
3. Operate the switch, valve, or other energy isolating devices so that the energy source(s) (electrical, mechanical, hydraulic, & other) is disconnected or isolated from the equipment.
4. Stored energy, such as that in capacitors, springs, elevated machine members, rotating fly wheels, hydraulic systems, and air, gas, steam or water pressure, must also be dissipated or restrained by methods such as grounding, repositioning, blocking, bleeding down.
5. Lockout energy isolating devices with an assigned individual lock.
6. After ensuring that no personnel are exposed and as a check on having disconnected the energy sources, operate the push button or other normal operating controls to make certain the equipment will not operate. CAUTION: Return operating controls to neutral position after the test.

Procedure Involving More Than One Person

If more than one individual is required to lock out equipment, each shall place his/her own personal lock on the energy

isolating device(s). One designated individual of a work crew or a Supervisor, with the knowledge of the crew, may lock out equipment for the whole crew. In such cases, it may be the responsibility of the individual to carry out all steps of the lockout procedure and inform the crew when it is safe to work on the equipment. Additionally, the designated individual shall not remove a crew lock until it has been verified that all individuals are clear.

Testing Equipment during Lockout

In many maintenance and repair operations, machinery may need to be tested, and for that purpose energized, before additional maintenance work can be performed. This procedure must be followed:

1. Clear all personnel to safety.
2. Clear away tools and materials from equipment.
3. Remove lockout devices and re-energize systems, following the established safe procedure.
4. Proceed with tryout or test.
5. Neutralize all energy sources once again, purge all systems, and lockout prior to continuing work.

Equipment design and performance limitations may dictate that effective alternative worker protection be provided when the established lock-out procedure is not feasible.

Restoring Equipment to Service

After the work is completed and the equipment is ready to be returned to normal operation, this procedure must be followed:

1. Remove all non-essential items.
2. See that all equipment components are operationally intact, including guards and safety devices. Repair or replace defective guards before removing lockouts.
3. Remove each lockout device using the correct removal sequence.
4. Make a visual check before restoring energy to ensure that everyone is physically clear of the equipment.

CONFINED SPACE OPERATIONS

Occasionally in our work, we may encounter confined spaces. Confined space work requires special safety precautions to ensure that employees are not overcome by dangerous air contaminants or oxygen deficiency. In some cases, there may be fire or explosion hazards in confined spaces that do not exist in open areas. Many workers have been killed or seriously injured in confined spaces. To avoid this, employees must adhere to the following rules. This section prescribes minimum standards for preventing employee exposure to dangerous air contamination and/or oxygen deficiency in confined spaces. In some cases, extra precautions may be necessary. As always, if you are unsure, ask for assistance.

Definitions

A confined space has the following properties:

1. Existing ventilation is insufficient to remove dangerous air contamination and/or oxygen deficiency that may exist or develop.
2. Ready access or egress for the removal of a suddenly disabled employee is difficult due to the location and/or size of the opening(s).
3. The area is not designed for continuous human occupancy.

Dangerous air contamination means an atmosphere presenting a threat of causing death, injury, acute illness, or disablement due to the presence of flammable and/or explosive, toxic, or otherwise injurious or incapacitating substances.

Dangerous air contamination due to the flammability of a gas or vapor is defined as an atmosphere containing the gas or vapor at a concentration greater than 20 percent of its lower explosive (lower flammable) limit.

Dangerous air contamination due to a combustible particulate is defined as a concentration greater than 20 percent of the minimum explosive concentration of the particulate.

Dangerous air contamination due to the toxicity of a substance is defined as the atmospheric concentration immediately hazardous to life or health. This definition of dangerous air contamination due to the toxicity of a substance does not preclude the requirement to control harmful exposures to toxic substances at concentrations less than those immediately hazardous to life or health.

Oxygen deficiency: An atmosphere containing oxygen at a concentration of less than 19.5 percent by volume.

Oxygen rich: An atmosphere containing oxygen at a concentration of more than 22 percent by volume. This creates additional fire hazards.

Typical Confined Spaces:

- * Vaults
- * Pits
- * Tubs
- * Vats
- * Ducts
- * Boilers

- * Silos
- * Sewers
- * Compartments

Prior to Confined Space Entry

1. Written, understandable operating and rescue procedures shall be developed and shall be provided to affected employees. The operating procedures shall include provision for the surveillance of the surrounding area to avoid hazards such as drifting vapors from tanks, piping and sewers.
2. All employees, including standby persons if needed, will be trained in the operating and rescue procedures, including instructions as to the hazards they may encounter.
3. Any lines, pipes or hoses which may convey flammable, injurious, or incapacitating substances into the space shall be disconnected, blinded, or blocked off by other positive means to prevent the development of dangerous air contamination and/or oxygen deficiency within the space. The disconnection or blind shall be so located or done in such a manner that inadvertent reconnection of the line or removal of the blind are effectively prevented.
4. The space shall be emptied, flushed, or otherwise purged of flammable, injurious or incapacitating substances to the extent feasible.
5. The air shall be tested with an appropriate device or method to determine whether dangerous air contamination and/or an oxygen deficiency exists and a written record of such testing results shall be made and kept at the work site for the duration of the work. Affected employees and/or their representative shall be afforded an opportunity to review and record the testing results.
6. Where interconnected spaces are blinded off as a unit, each space shall be tested and the results recorded. The most hazardous condition found shall govern the entry procedures to be followed.

Confined Space Entry if Tests Show No Hazard

If dangerous air contamination and/or oxygen deficiency does not exist within the space, as demonstrated by tests performed in accordance with the pre-entry procedures, entry into and work within the space may proceed subject to the following provisions:

1. Air testing, in accordance with the pre-entry procedures, shall be conducted with sufficient frequency to ensure that the development of dangerous air contamination and/or oxygen deficiency does not occur during the performance of any operation.
2. Work stops, employees exit, and additional precautions are taken if dangerous air contamination and/or oxygen deficiency does develop.

Confined Space Entry if Tests Show Hazards are Present or are Likely to Develop

Where the existence of dangerous air contamination and/or oxygen deficiency is demonstrated by tests performed in accordance with the pre-entry procedures or if the development of dangerous air contamination and/or an oxygen deficiency

is imminent, the following requirements shall also apply:

1. Existing ventilation shall be augmented by appropriate means.
2. When additional ventilation has removed dangerous air contamination and/or oxygen deficiency as demonstrated by additional testing conducted (and recorded), entry into and work within the space may proceed.
3. No source of ignition shall be introduced until the implementation of appropriate provisions of this section have ensured that dangerous air contamination due to flammable and/or explosive substances does not exist.
4. Whenever oxygen-consuming equipment such as welding torches, furnaces and the like are to be used, measures shall be taken to ensure adequate combustion air and exhaust gas venting.
5. To the extent feasible, provision shall be made to permit ready entry and exit.
6. Where it is not feasible to provide for ready exit from spaces equipped with automatic fire suppression systems employing harmful design concentrations of toxic or oxygen-displacing gases, or total foam flooding, such systems shall be deactivated. Where it is not practical or safe to deactivate such systems, the use of respiratory protective equipment, such as SCBA, shall apply during entry into and work within such spaces.

Confined Spaces Where Dangerous Air Contamination Cannot be Removed by Ventilation

It is the policy of the company to only work in a confined space if it can be made safe by the means listed above. We will not work in confined spaces where there is an ongoing hazard of air contamination or oxygen deficiency. These operations require extra measures and precautions beyond our immediate ability to perform. If such work does become necessary, a separate program will be developed.

FORKLIFTS

Each year about 100 workers are killed and almost 95,000 injured in industrial truck accidents across the country. To properly protect our employees from such accidents, the company has adopted the following Forklift Safety Program.

General

The company will ensure that each powered industrial truck operator is competent to operate a powered industrial truck safely, as demonstrated by the successful completion of the training and evaluation specified below.

Prior to permitting an employee to operate a powered industrial truck (except for training purposes), the company shall ensure that the employee has successfully completed a training program.

Training Program Implementation

Trainees may operate a powered industrial truck only:

- under the direct supervision of persons who have the knowledge, training, and experience to train operators and evaluate their competence
- where such operation does not endanger the trainee or other employees.

Training shall consist of a combination of formal instruction (e.g., lecture, discussion, interactive computer learning, video tape, written material), practical training (demonstrations performed by the trainer and practical exercises performed by the trainee), and evaluation of the operator's performance in the workplace.

All operator training and evaluation shall be conducted by persons who have the knowledge, training, and experience to train powered industrial truck operators and evaluate their competence.

Note: This section does not require that the training be given by any particular individual or organization. The trainer must only be able to demonstrate that they have appropriate knowledge, training and experience to train others and evaluate their competence.

Training Program Content

Powered industrial truck operators shall receive initial training in the following topics.

- Operating instructions, warnings, and precautions for the types of truck the operator will be authorized to operate;
- Differences between the truck and the automobile;
- Truck controls and instrumentation: where they are located, what they do, and how they work;
- Engine or motor operation;
- Steering and maneuvering;
- Visibility (including restrictions due to loading);
- Fork and attachment adaptation, operation, and use limitations;

- Vehicle capacity;
- Vehicle stability;
- Any vehicle inspection and maintenance that the operator will be required to perform;
- Refueling and/or charging and recharging of batteries;
- Operating limitations;
- Any other operating instructions, warnings, or precautions listed in the operator's manual for the types of vehicle that the employee is being trained to operate.
- Workplace-related topics:
 - Surface conditions where the vehicle will be operated;
 - Composition of loads to be carried and load stability;
 - Load manipulation, stacking, and un stacking;
 - Pedestrian traffic in areas where the vehicle will be operated;
 - Narrow aisles and other restricted places where the vehicle will be operated;
 - Hazardous locations where the vehicle will be operated;
 - Ramps and other sloped surfaces that could affect the vehicle's stability;
 - Closed environments and other areas where insufficient ventilation or poor vehicle maintenance could cause a buildup of carbon monoxide or diesel exhaust;
 - Other unique or potentially hazardous environmental conditions in the workplace that could affect safe operation;
 - The requirements of this section.

Refresher Training and Evaluation

Refresher training, including an evaluation of the effectiveness of that training, shall be conducted to ensure that the operator has the knowledge and skills needed to operate the powered industrial truck safely.

Refresher training in relevant topics shall be provided to the operator when:

- The operator has been observed to operate the vehicle in an unsafe manner;
- The operator has been involved in an accident or near-miss incident;
- The operator has received an evaluation that reveals that the operator is not operating the truck safely;
- The operator is assigned to drive a different type of truck; or
- A condition in the workplace changes in a manner that could affect safe operation of the truck.

An evaluation of each powered industrial truck operator's performance shall be conducted at least once every three years.

Avoidance of Duplicative Training

If an operator has previously received training in a topic specified above, and such training is appropriate to the truck and working conditions encountered, additional training in that topic is not required if the operator has been evaluated and found competent to operate the truck safely.

Note: This section reduces the training requirement for previously trained operators provided we can demonstrate that the operator knows the material. Since some of the required training is unique to the area where the lift will be operated, we must still cover these areas even if the employee was previously trained.

Certification

The company shall certify that each operator has been trained and evaluated as required by this paragraph (l). The certification shall include the name of the operator, the date of the training, the date of the evaluation, and the identity of the person(s) performing the training or evaluation.

RECORDKEEPING

The program administrator will ensure the maintenance of all Safety Program records, for the listed periods, including:

- | | |
|--|----------------------|
| 1. New Employee Safety Orientation forms | length of employment |
| 2. Code of Safe Practices Receipt | length of employment |
| 3. Disciplinary actions for safety | 1 year |
| 4. Safety inspections | 2 years |
| 5. Safety meeting reports | 2 years |
| 6. Safety Contact Reports | 2 years |
| 7. Accident investigations | 5 years |
| 8. Federal or State OSHA log of injuries | 5 years |
| 9. Inventory of Hazardous Materials (if any) | forever |
| 10. Employee exposure or medical records | forever |

Records are available for review at the main office.

APPENDIXES

1. HAZARD ASSESSMENT AND CORRECTION RECORD
2. ACCIDENT / EXPOSURE INVESTIGATION FORM
3. WORKER TRAINING AND INSTRUCTION RECORD
4. EMPLOYEE SAFETY CONTACT REPORT
5. NEW EMPLOYEE SAFETY ORIENTATION
6. CODE OF SAFE WORK PRACTICES RECEIPT
7. COMPANY VEHICLE POLICY RECEIPT
8. SAFETY COMMITTEE MEETING MINUTES
9. SAFETY MEETING MINUTES
10. VEHICLE INSPECTION CHECKLIST
11. FACILITY INSPECTION CHECKLISTS

HAZARD ASSESSMENT AND CORRECTION RECORD

Date of Inspection: _____

Person Conducting Inspection: _____

Unsafe Condition or Work Practice:

Corrective Action Taken:

Date of Inspection: _____

Person Conducting Inspection: _____

Unsafe Condition or Work Practice:

Corrective Action Taken:

Date of Inspection: _____

Person Conducting Inspection: _____

Unsafe Condition or Work Practice:

Corrective Action Taken:

ACCIDENT / EXPOSURE INVESTIGATION REPORT

Date & Time of Accident:

Location:

Accident Description:

Workers Involved:

Preventive Action Recommendations:

Corrective Actions Taken:

NEW EMPLOYEE SAFETY ORIENTATION

The Supervisor will verbally cover the following items with each new employee on the first day of their employment.

Employee Name: _____
Start Date: _____
Job Title / Position: _____

Instruction has been received in the following areas.

- 1. Code of Safe Practices.*
- 2. Hazard Communication (chemicals) Employee Training Handbook.*
- 3. Driving Safety Rules.*
- 4. Safety rule enforcement procedures.
- 5. Necessity of reporting ALL injuries, no matter how minor, IMMEDIATELY.
- 6. Proper method of reporting safety hazards.
- 7. Emergency procedures and First Aid.
- 8. Proper work clothing & required personal protective equipment.
- 9. List all special equipment, such as lifts, employee is trained and authorized to use.
- 10. Emergency Exits and Fire Extinguishers.

* Give a copy of these items to the employee.

I agree to abide by all company safety polices and the Code of Safe Practices. I also understand that failure to do so may result in disciplinary action and possible termination.

Signed _____ Date _____
Employee

Signed _____ Date _____
Supervisor

Supervisor

CODE OF SAFE PRACTICES RECEIPT

This is to certify that I have received a copy of the Code of Safe Practices. I have read these instructions, understand them, and will comply with them while working for the company.

I understand that failure to abide by these rules may result in disciplinary action and possible termination of my employment with the company.

I also understand that I am to report any injury to my Supervisor or Manager immediately and report all safety hazards. I

further understand that I have the following rights.

- * I am not required to work in any area I feel is not safe.
- * I am entitled to information on any hazardous material or chemical I am exposed to while working.
- * I am entitled to see a copy of the Safety Manual and Injury and Illness Prevention Program.
- * I will not be discriminated against for reporting safety concerns.

Print Name

Sign Name

Date

Copy: Employee
File

COMPANY VEHICLE POLICY RECEIPT

This is to certify that I have received a copy of the Driving Safety Rules and Company Vehicle Policy. I have read these instructions, understand them, and will comply with them while driving company vehicles.

I understand that failure to abide by these rules will result in disciplinary action and possible suspension of my driving privileges. I

also understand that I am to report any accident to the office immediately.

Print Name

Sign Name

Date

Copy: Employee File

SAFETY COMMITTEE MEETING MINUTES

Date of Committee Meeting: _____ *Location:* _____

Minutes prepared by: _____ *Date:* _____

Review of Safety Inspection and Plan of Correction:

Previous Business: _____

New Business: _____

Review of Accidents: _____

Plan of Correction: _____

Employee Suggestions: _____

Recommended Safety Training: _____

Additional Comments: _____

Safety Committee Meeting Attendance:

- | | |
|----------|----------|
| 1. _____ | 2. _____ |
| 3. _____ | 4. _____ |
| 5. _____ | 6. _____ |
| 7. _____ | 8. _____ |

9. _____

11. _____

13. _____

15. _____

17. _____

19. _____

10. _____

12. _____

14. _____

16. _____

18. _____

20. _____

SAFETY MEETING MINUTES

Company: _____ Department: _____

Presenter: _____ Date: _____

Safety Topic Discussed:

Additional items addressed other than topic:

Suggestions and Comments:

Safety Meeting Attendance:

- | | |
|-----------|-----------|
| 1. _____ | 2. _____ |
| 3. _____ | 4. _____ |
| 5. _____ | 6. _____ |
| 7. _____ | 8. _____ |
| 9. _____ | 10. _____ |
| 11. _____ | 12. _____ |
| 13. _____ | 14. _____ |
| 15. _____ | 16. _____ |
| 17. _____ | 18. _____ |

Vehicle Inspection Checklist

Driver _____ Date _____
Vehicle _____ Mileage _____

The items on this inspection sheet should be checked daily. A separate sheet should be filled out for each vehicle driven. Example: If you drive vehicle #3614 and swap to #7659 during the day, 2 inspection sheets should be filled out for that day. These forms are due daily. Place an X by any item that needs attention. Place a check mark by the rest. Any discrepancies should be detailed on the bottom of this sheet.

- ____ Ignition Key
- ____ Fuel Key
- ____ Check Radio (Two way check)
- ____ Visual Inspection for Exterior Damage/Leaks under vehicle
- ____ Check inside Engine compartment for Leaks/loose items
- ____ Oil Level
- ____ Washer Fluid Level
- ____ Coolant Level
- ____ Power Steering Fluid Level
- ____ Start Engine and check Transmission Fluid Level (Fluid should be hot)
- ____ Check for Air Gauge
- ____ Check Tires for wear and pressure (**70 PSI COLD**) LF _____ LR _____ RF _____ RR _____
- ____ Check Horn
- ____ Check Heater/Defroster
- ____ Check Windshield Wipers/Washers
- ____ Check Highlight/Signal lights/4way flashes/Tail lights/Backup lights/Horn
- ____ Check Lift, run one Complete Cycle
- ____ Check Interior lights
- ____ Check Mirrors for damage and adjustments
- ____ Check fuel level (**Should Not be Less Than ½ Tank**)
- ____ Check First Aid Kit on Board and full
- ____ Check Fire Extinguisher on board/Gauge showing charged, proper seal & pin
- ____ Check Adequate tie-downs/Tie-down Tracks (must be clean)
- ____ Check BIOHAZ KIT (Seal)
- ____ As you drive, continually check for any strange smells, sounds, vibrations, or anything that does not feel right.

*Form to be completed and turned in to Operations Manager DAILY.

The following discrepancies were noted: _____

Driver's Signature: _____

Corrective action taken: _____

FACILITY INSPECTION CHECKLIST

Department/Division: _____

Date Of Inspection: _____

Location: _____

Inspector: _____

Criteria	Check One		Comments
	Yes	No	
• Are work areas properly illuminated?	<input type="checkbox"/>	<input type="checkbox"/>	
• Is the ventilation system appropriated for the work performed?	<input type="checkbox"/>	<input type="checkbox"/>	
• Are restrooms and washrooms kept clean and sanitary?	<input type="checkbox"/>	<input type="checkbox"/>	
• Is potable water provided for drinking and washing?	<input type="checkbox"/>	<input type="checkbox"/>	
• Are outlets for water not suitable for drinking clearly identified?	<input type="checkbox"/>	<input type="checkbox"/>	
• Where heat stress is a problem, do all fixed work areas have air conditioning?	<input type="checkbox"/>	<input type="checkbox"/>	
• Is the work area clean and orderly?	<input type="checkbox"/>	<input type="checkbox"/>	
• Are floors kept clean and dry or have you taken appropriate measures to make floors slip resistant?	<input type="checkbox"/>	<input type="checkbox"/>	
• Are floors free from protruding nails, splinters, holes, etc.?	<input type="checkbox"/>	<input type="checkbox"/>	
• Are permanent aisles and passageways clearly marked?	<input type="checkbox"/>	<input type="checkbox"/>	
• Are aisles and passageways kept clear?	<input type="checkbox"/>	<input type="checkbox"/>	
• Are pits and floor openings covered or guarded?	<input type="checkbox"/>	<input type="checkbox"/>	
• Is combustible trash removed from the worksite daily?	<input type="checkbox"/>	<input type="checkbox"/>	
• Are spilled materials or liquids cleaned up immediately?	<input type="checkbox"/>	<input type="checkbox"/>	
• Is there safe clearance in aisles where motorized or mechanical handling equipment travel?	<input type="checkbox"/>	<input type="checkbox"/>	
 FLOOR AND WALL OPENINGS, STAIRS AND STAIRWAYS			
• Are floor openings guarded by covers or guardrails on all sides?	<input type="checkbox"/>	<input type="checkbox"/>	
• Do skylights have screens or fixed railings that would prevent someone on the roof from falling through?	<input type="checkbox"/>	<input type="checkbox"/>	
• Are open pits and trap doors guarded?	<input type="checkbox"/>	<input type="checkbox"/>	
• Are grates or similar type covers over floor openings such as floor drains, designed so that foot traffic or rolling equipment are not affected by grate spacing?	<input type="checkbox"/>	<input type="checkbox"/>	
• Are open-sided floors, platforms and runways having a drop of more than 4 feet guarded by a standard railing or toe board?	<input type="checkbox"/>	<input type="checkbox"/>	
• Are standard stair rails or handrails on all stairways having four or more risers?	<input type="checkbox"/>	<input type="checkbox"/>	
• Are all stairways at least 22 inches wide?	<input type="checkbox"/>	<input type="checkbox"/>	
• Do stairs have at least a 6-½ foot overhead clearance?	<input type="checkbox"/>	<input type="checkbox"/>	

<ul style="list-style-type: none"> • Are step risers on stairs uniform from top to bottom? 	<input type="checkbox"/>	<input type="checkbox"/>	
<ul style="list-style-type: none"> • Are steps on stairs and stairways designed or provided with a slip-resistant surface? 	<input type="checkbox"/>	<input type="checkbox"/>	
<ul style="list-style-type: none"> • Are stairway handrails located between 30 and 34 inches above the leading edge of stair treads? 	<input type="checkbox"/>	<input type="checkbox"/>	

GENERAL WORK ENVIRONMENT

Criteria	Check One		Comments
	Yes	No	
<ul style="list-style-type: none"> • Are stairway handrails capable of withstanding a load of 200 pounds, applied in any direction? 	<input type="checkbox"/>	<input type="checkbox"/>	
ELEVATED SURFACES			
<ul style="list-style-type: none"> • Is the vertical distance between stairway landings limited to 12 feet or less? • Are stairways adequately illuminated? • Are signs posted showing the elevated surface load capacity? • Do elevated work areas have a permanent means of access and egress? • Are materials on elevated surfaces piled, stacked or racked in a manner to prevent tipping, falling, collapsing, rolling or spreading? 	<input type="checkbox"/>	<input type="checkbox"/>	
EXITS AND EXIT DOORS			
<ul style="list-style-type: none"> • Are all exits marked with an exit sign and illuminated by a reliable light source? • Are exit routes clearly marked? • Are doors, passageways or stairways that are neither exits nor access to exits, appropriately marked "NOT AN EXIT" or "STOREROOM" etc.? • Are all exits kept free of obstructions? • Are there sufficient exits to permit prompt escape in case of emergency? • Do exit doors open in the direction of exit travel? • Are doors that swing in both directions provided with viewing panels in each door? • Are exits and exit routes equipped with emergency lighting? 	<input type="checkbox"/>	<input type="checkbox"/>	
ADDITIONAL REMARKS:			

Additional information regarding this safety program manual can be obtained through the safety program administrator or safety committee.