

ASTON SERIES COMPACT

Water Source/Geothermal Heat Pump

- R-410A Refrigerant
- Commercial 0.75-6 Ton

Installation Information

Water Piping Connections

Hot Water Connections

Electrical

Startup Procedures

Troubleshooting

Preventive Maintenance



Table of Contents

Model Nomenclature	4
General Installation Information	5
Dimensional Data	6
Installing Horizontal Units	10
Hanger Bracket Locations	11
Duct System	12
Water Piping	12
Condensate Drain	12
Water Quality	13
System Cleaning and Flushing	13
Open Loop Ground Water Systems	14
Hot Water Generator Connections	15
Freeze Detection	17
Electrical Connections	17
Electrical Data	18
Blower Performance Data	21
Wiring Schematics	26
Controls	31
Unit Startup	40
Operating Limits	41
Operating Parameters	41
Pressure Drop	43
Reference Calculations and Legend	44
Refrigerant Circuit Guideline	44
Compressor and Thermistor Resistance	45
Heat of Extraction/Rejection Data	46
Troubleshooting	47
Preventive Maintenance and Replacement Parts	50
Service Parts	51
Revision Guide	55

Model Nomenclature

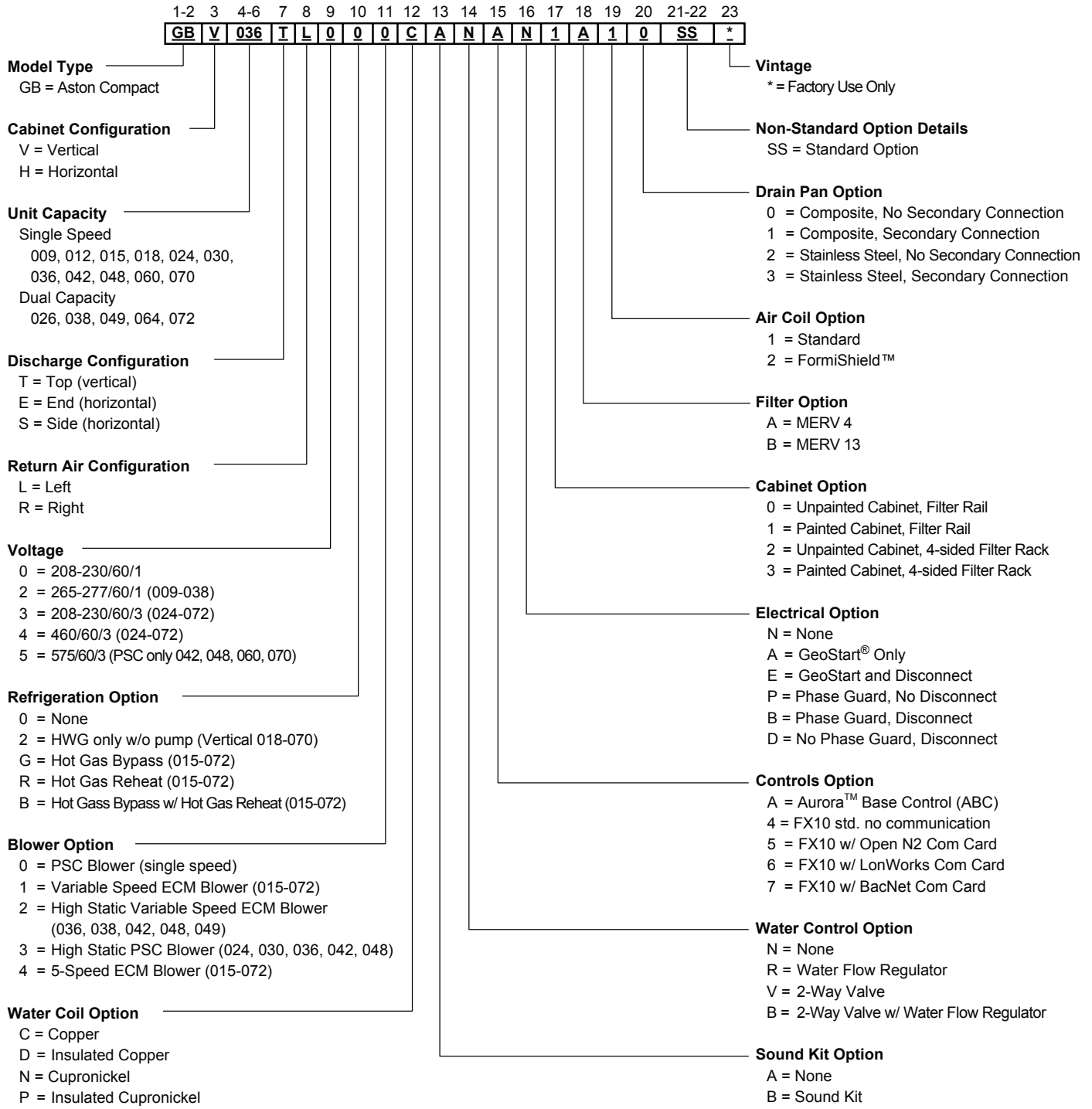

Rev.: 25 February 2013D

NOTES: Phase guard only available on 208-230/60/3, 460/60/3, and 575/60/3

General Installation Information

Safety Considerations



WARNING: Before performing service or maintenance operations on a system, turn off main power switches to the indoor unit. If applicable, turn off the accessory heater power switch. Electrical shock could cause personal injury.

Installing and servicing heating and air conditioning equipment can be hazardous due to system pressure and electrical components. Only trained and qualified service personnel should install, repair or service heating and air conditioning equipment. Untrained personnel can perform the basic maintenance functions of cleaning coils and cleaning and replacing filters. All other operations should be performed by trained service personnel. When working on heating and air conditioning equipment, observe precautions in the literature, tags and labels attached to the unit and other safety precautions that may apply.

Follow all safety codes. Wear safety glasses and work gloves. Use a quenching cloth for brazing operations and have a fire extinguisher available.

Moving and Storage

Move units in the normal "up" orientation. Horizontal units may be moved and stored per the information on the packaging. Do not stack more than three units in total height. Vertical units may be stored one upon another to a maximum height of two units. Do not attempt to move units while stacked. When the equipment is received, all items should be carefully checked against the bill of lading to be sure all crates and cartons have been received. Examine units for shipping damage, removing the units from the packaging if necessary. Units in question should also be internally inspected. If any damage is noted, the carrier should make the proper notation on the delivery receipt, acknowledging the damage.

Unit Location

Locate the unit in an indoor area that allows for easy removal of the filter and access panels. Location should have enough space for service personnel to perform maintenance or repair. Provide sufficient room to make water, electrical and duct connection(s). If the unit is located in a confined space, such as a closet, provisions must be made for return air to freely enter the space by means of a louvered door, etc. Any access panel screws that would be difficult to remove after the unit is installed should be removed prior to setting the unit. On horizontal units, allow adequate room below the unit for a condensate drain trap and do not locate the unit above supply piping. Care should be taken when units are located in unconditioned spaces to prevent damage from frozen water lines and excessive heat that could damage electrical components.

Installing Vertical Units

Prior to setting the unit in place, remove and discard the compressor hold down shipping bolt located at the front of the compressor mounting bracket.

Vertical units are available in left or right air return configurations. Top flow vertical units should be mounted level on a vibration absorbing pad slightly larger than the base to provide isolation between the unit and the floor. It is not necessary to anchor the unit to the floor (see figure below).

Vertical Unit Mounting

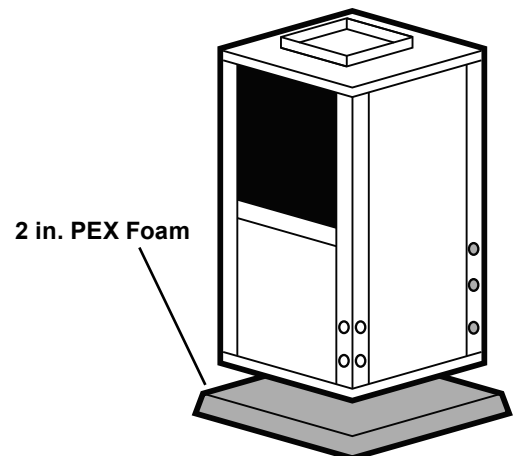

Vertical Dimensional Data

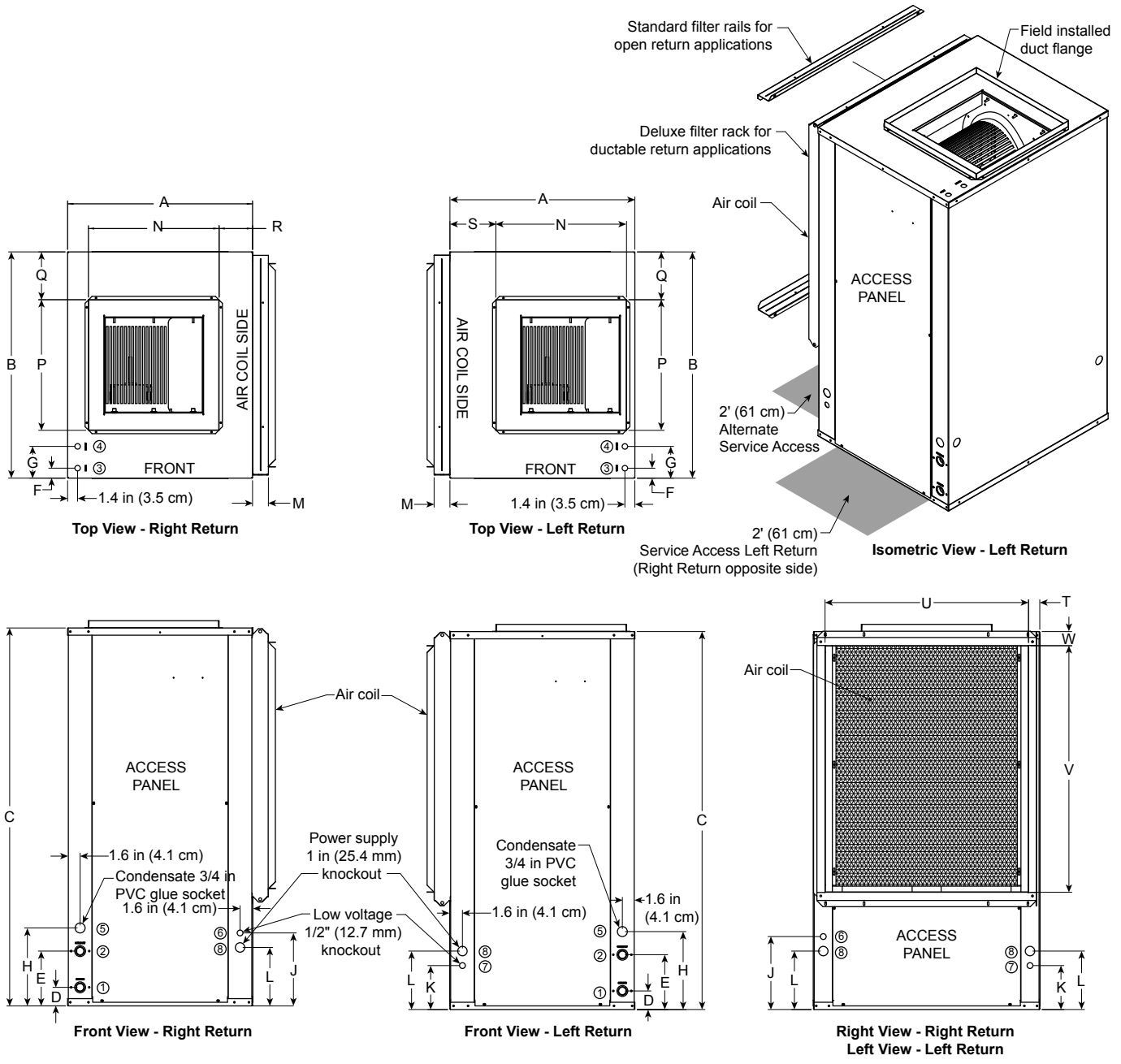

Vertical Dimensional Data cont.

Vertical Models		Overall Cabinet			Water Connections							Electrical Knockouts		
					1	2	3	4	5			6	7	8
		A	B	C	D	E	F	G	H	Loop	Knockout	J	K	L
		Width	Depth	Height*	In	Out	HWG In	HWG Out	Condensate	Water FPT	HWG Provisions	1/2 in. cond	1/2 in. cond	1 in. cond
009-012	in.	22.5	22.2	30.2	2.6	7.6	N/A	N/A	10.8	1/2 in.	N/A	9.4	5.4	7.4
	cm.	57.2	56.4	76.7	6.6	19.3	N/A	N/A	27.4	12.7 mm	N/A	23.9	13.7	18.8
015-018	in.	22.5	26.2	40.2	2.6	7.6	1.4	4.4	10.8	3/4 in.	0.875	10.1	6.1	8.1
	cm.	57.2	66.5	102.1	6.6	19.3	3.6	11.2	27.4	19.1 mm	22.2 mm	25.7	15.5	20.6
024-030	in.	22.5	26.2	44.2	2.6	7.6	1.4	4.4	10.8	3/4 in.	0.875	10.1	6.1	8.1
	cm.	57.2	66.5	112.3	6.6	19.3	3.6	11.2	27.4	19.1 mm	22.2 mm	25.7	15.5	20.6
036-038	in.	25.5	31.2	44.2	2.6	7.6	1.4	4.4	10.8	1 in.	0.875	10.1	6.1	8.1
	cm.	64.8	79.2	112.3	6.6	19.3	3.6	11.2	27.4	25.4 mm	22.2 mm	25.7	15.5	20.6
042-049	in.	25.5	31.2	48.2	2.6	7.6	1.4	4.4	10.8	1 in.	0.875	10.1	6.1	8.1
	cm.	64.8	79.2	122.4	6.6	19.3	3.6	11.2	27.4	25.4 mm	22.2 mm	25.7	15.5	20.6
060-072	in.	25.5	31.2	52.2	2.6	7.6	1.4	4.4	10.8	1 in.	0.875	10.1	6.1	8.1
	cm.	64.8	79.2	132.6	6.6	19.3	3.6	11.2	27.4	25.4 mm	22.2 mm	25.7	15.5	20.6

3/16/12

Vertical Models		Discharge Connection duct flange installed (±0.10 in)						**Return Connection using deluxe filter rack (±0.10 in)			
		M	N	P	Q	R	S	T	U	V	W
		Filter Rack Width	Supply Width	Supply Depth					Return Depth	Return Height	
009-012	in.	2.2	10.0	10.0	6.1	5.3	9.8	2.0	18.1	14.0	2.0
	cm.	5.6	25.4	25.4	15.5	13.5	24.9	5.1	46.0	35.6	5.1
015-018	in.	2.2	14.0	14.0	6.1	4.5	7.7	2.0	22.1	22.0	1.9
	cm.	5.6	35.6	35.6	15.5	11.4	19.6	5.1	56.1	55.9	4.8
024-030	in.	2.2	14.0	14.0	6.1	4.5	7.7	2.0	22.1	26.1	1.8
	cm.	5.6	35.6	35.6	15.5	11.4	19.6	5.1	56.1	66.3	4.6
036-038	in.	2.2	18.0	18.0	6.6	4.6	6.3	1.6	28.1	26.1	2.0
	cm.	5.6	45.7	45.7	16.8	11.7	16.0	4.1	71.4	66.3	5.1
042-049	in.	2.2	18.0	18.0	6.6	4.6	6.3	1.6	28.1	30.0	2.0
	cm.	5.6	45.7	45.7	16.8	11.7	16.0	4.1	71.4	76.2	5.1
060-072	in.	2.2	18.0	18.0	6.6	5.0	6.4	1.6	28.1	34.0	2.0
	cm.	5.6	45.7	45.7	16.8	12.7	16.3	4.1	71.4	86.4	5.1

Condensate is 3/4 in. PVC female glue socket and is switchable from side to front.

*Discharge flange is field installed and extends 1 in. (25.4 mm) from top of cabinet.

**Vertical units shipped with standard 2 in. (field adjustable to 1 in.) open application filter rack extending 2.2 in. from unit and is not suitable for duct connection, for ductable return connection applications, order the deluxe 2 in. (field adjustable to 1 in.) duct collar/filter rack which extends 3.25 in. from the unit and is suitable for duct connections.

3/16/12

Vertical Disconnect

When using disconnect, do not use dimension L from the standard vertical dimensional data. Use dimension LL from the vertical disconnect dimensional data.

Vertical Models	LL
009-012	17.8 [45.2]
015-018	14.3 [36.3]
024-030	15.3 [38.9]
036-038	14.3 [36.3]
042-049	14.3 [36.3]
060-064	14.3 [36.3]
070-072	External

Dimensions in inches [cm]

3/16/12

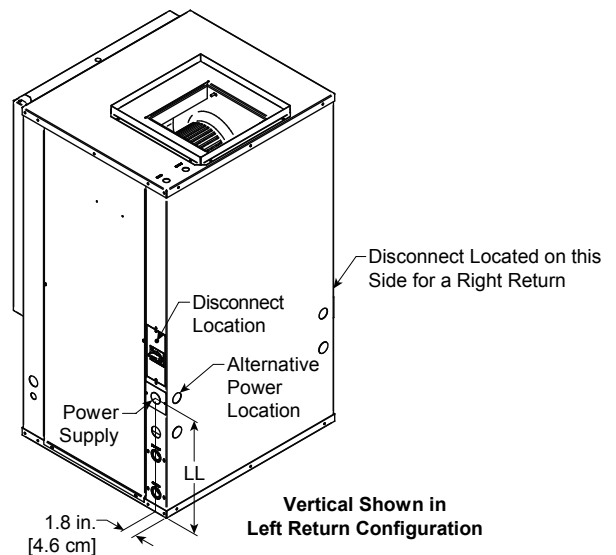

Horizontal Dimensional Data

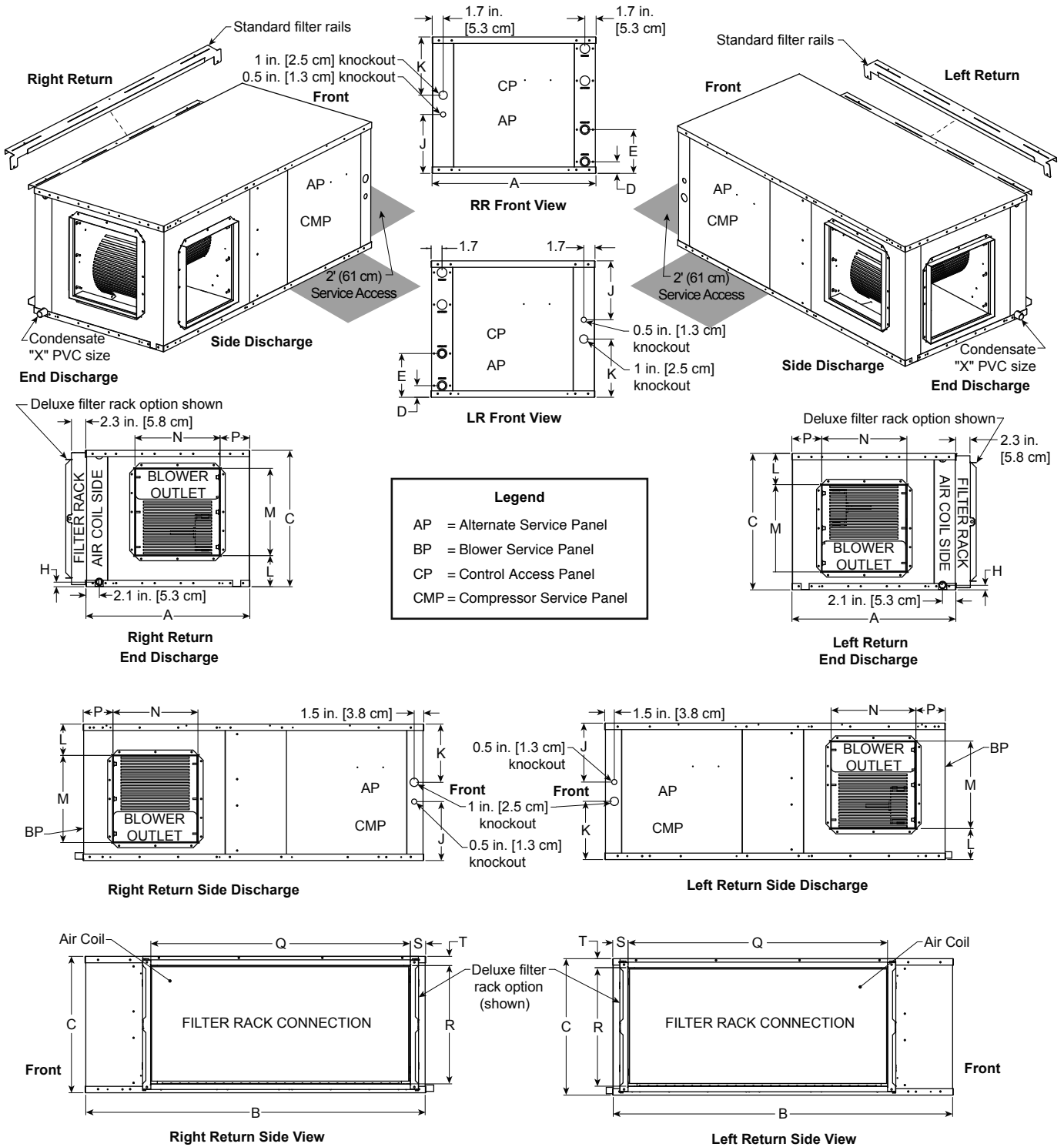

Horizontal Dimensional Data cont.

Horizontal Models	Overall Cabinet			Water Connections				Electrical Knockouts		
	A	B	C	1	2	3		J	K	
	Width	Depth	Height*	D	E	H	Loop	1/2 in. cond	1 in. cond	
				In	Out	Condensate	Water FPT	Low Voltage	Power Supply	
009-012	in.	22.5	35.0	17.2	1.8	6.8	0.8	1/2 in.	7.1	7.1
	cm.	57.2	88.9	43.7	4.6	17.3	2.0	12.7 mm	18.0	18.0
015-018	in.	22.5	42.0	19.2	1.8	6.8	0.8	3/4 in.	9.1	7.1
	cm.	57.2	106.7	48.8	4.6	17.3	2.0	19.05 mm	23.1	18.0
024-030	in.	22.5	45.0	19.2	1.8	6.8	0.8	3/4 in.	9.2	7.1
	cm.	57.2	114.3	48.8	4.6	17.3	2.0	19.05 mm	23.4	18.0
036-038	in.	25.5	48.0	21.2	1.8	6.8	0.8	1 in.	9.2	9.1
	cm.	64.8	121.9	53.8	4.6	17.3	2.0	25.4 mm	23.4	23.1
042-049	in.	25.5	53.0	21.2	1.8	6.8	0.8	1 in.	9.2	9.1
	cm.	64.8	134.6	53.8	4.6	17.3	2.0	25.4 mm	23.4	23.1
060-064	in.	25.5	61.0	21.2	1.8	6.8	0.8	1 in.	9.2	9.1
	cm.	64.8	154.9	53.8	4.6	17.3	2.0	25.4 mm	23.4	23.1
070-072	in.	25.5	68.0	21.2	1.8	6.8	0.8	1 in.	9.2	9.1
	cm.	64.8	172.7	53.8	4.6	17.3	2.0	25.4 mm	23.4	23.1

3/16/12

Horizontal Models	Discharge Connection duct flange installed (±0.10 in.)				Return Connection using deluxe filter rack option (±0.10 in.)				PVC Size	
	L	M	N	P	Q	R	S	T	X	
		Supply Width	Supply Depth		Return Depth	Return Height				
009-012	in.	5.9	7.2	9.5	6.0	16.4	14.5	2.0	1.4	3/4"
	cm.	15.0	18.3	24.1	15.2	41.7	36.8	5.1	3.6	1.9
015-018	in.	6.7	10.5	9.4	4.9	27.4	16.6	2.0	1.4	3/4"
	cm.	17.0	26.7	23.9	12.4	69.6	42.2	5.1	3.6	1.9
024-030	in.	6.7	10.5	9.4	4.9	30.4	16.6	2.0	1.5	3/4"
	cm.	17.0	26.7	23.9	12.4	77.2	42.2	5.1	3.8	1.9
036-038	in.	4.9	13.6	13.2	4.6	35.4	18.6	2.3	1.4	3/4"
	cm.	12.4	34.5	33.5	11.7	89.9	47.2	5.8	3.6	1.9
042-049	in.	4.9	13.6	13.2	4.6	40.4	18.6	2.3	1.4	3/4"
	cm.	12.4	34.5	33.5	11.7	102.6	47.2	5.8	3.6	1.9
060-064	in.	4.9	13.6	13.2	4.6	45.4	18.6	2.3	1.4	3/4"
	cm.	12.4	34.5	33.5	11.7	115.3	47.2	5.8	3.6	1.9
070-072	in.	4.9	13.6	13.2	4.6	45.4	18.6	2.3	1.4	3/4"
	cm.	12.4	34.5	33.5	11.7	115.3	47.2	5.8	3.6	1.9

3/16/12

Horizontal units shipped with standard 2 in. (field adjustable to 1 in.) open application filter rack extending 2.2 in. from unit and is not suitable for duct connection, for ductable return connection applications, order the deluxe 2 in. (field adjustable to 1 in.) filter rail/filter rack which extends 3.25 in. from the unit and is suitable for duct connections.

Horizontal Disconnect

When using disconnect, do not use dimension K from the standard horizontal dimensional data. Use dimension KK from the horizontal disconnect dimensional data.

Horizontal Models	KK
009-012	8.2 [20.8]
015-018	9.2 [23.4]
024-030	9.2 [23.4]
036-038	11.2 [28.4]
042-049	10.2 [25.9]
060-064	11.2 [28.4]
070-072	10.2 [25.9]

Dimensions in inches [cm]

3/16/12

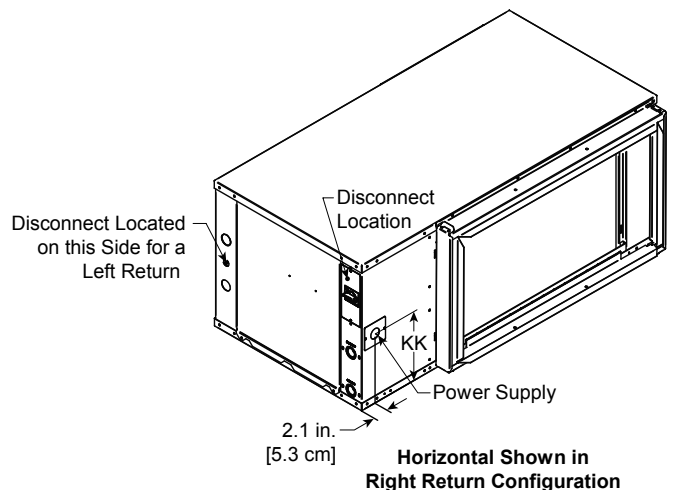

Installing Horizontal Units

Installing Horizontal Units

Remove and discard the compressor hold down shipping bolt located at the front of the compressor mounting bracket prior to setting the unit in place. Horizontal units are available with side or end discharge.

NOTE: Left (Right) Return Side Discharge cannot be converted to Left (Right) Return End Discharge or vice versa, without additional custom sheet metal parts. Horizontal units are normally suspended from a ceiling by four (009-060 models) or five (070-072 models) 3/8 in. diameter threaded rods. The rods are usually attached to the unit by hanger bracket kits furnished with each unit.

Lay out the threaded rods per the Hanger Bracket Dimensions table. Assemble the hangers to the unit as shown. Securely tighten the brackets to the unit using the weld nuts located on the underside of the bottom panel. When attaching the hanger rods to the bracket, a double nut is required since vibration could loosen a single nut. To allow filter access, install hanger brackets as illustrated in the Hanger Bracket Locations section. The unit

should be pitched approximately 1/4 in. towards the drain in both directions to facilitate the removal of condensate. Use only the bolts provided in the kit to attach hanger brackets. The use of longer bolts could damage internal parts.

Some applications require the installation of horizontal units on an attic floor. In this case, the unit should be set in a full size secondary drain pan on top of a vibration absorbing pad. The secondary drain pan prevents possible condensate overflow or water leakage damage to the ceiling. The secondary drain pan is usually placed on a plywood base isolated from the ceiling joists by additional layers of vibration absorbing material.



CAUTION: Do not use rods smaller than 3/8 in. diameter since they may not be strong enough to support the unit. The rods must be securely anchored to the ceiling.

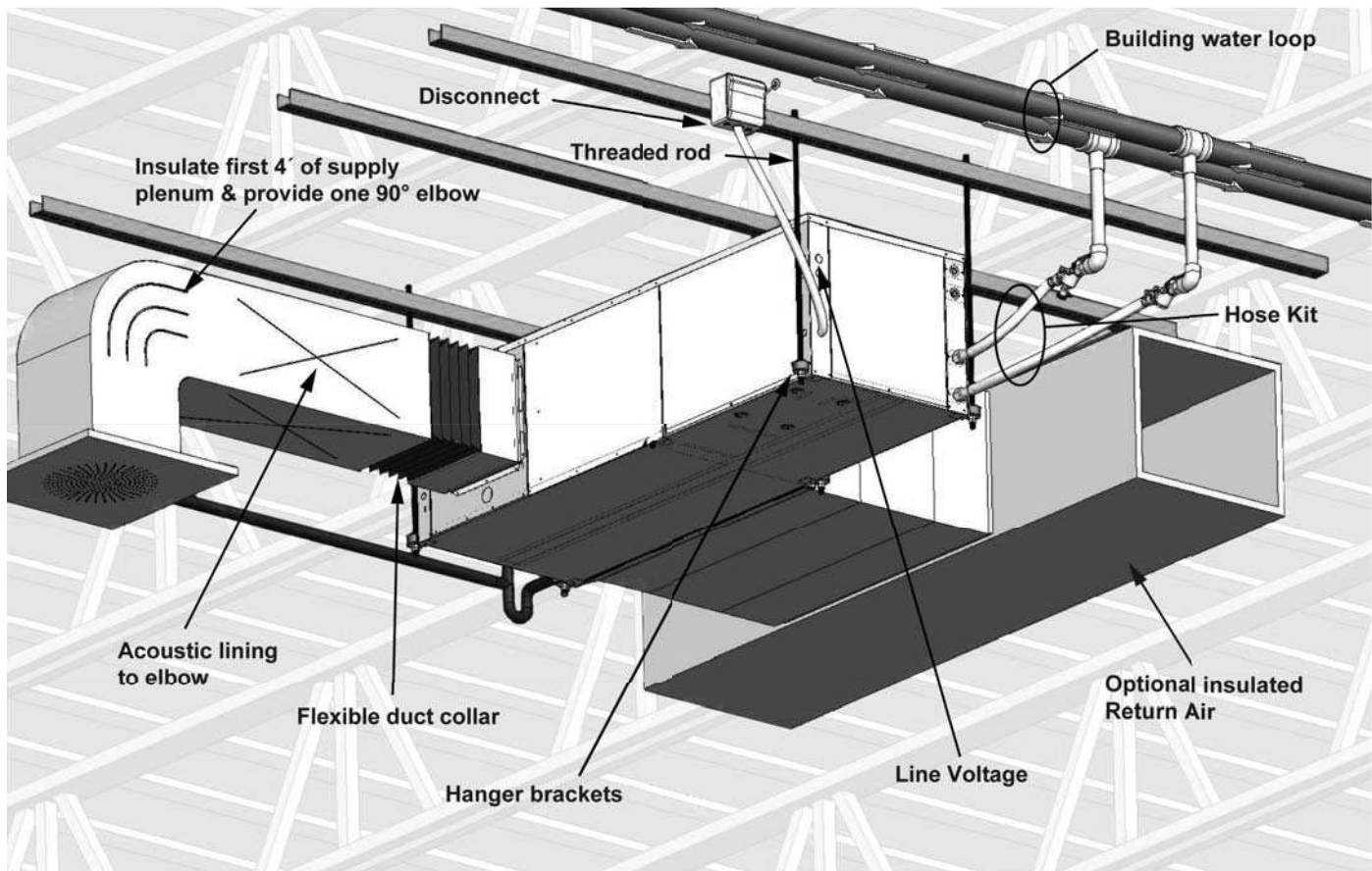

Hanger Bracket Locations

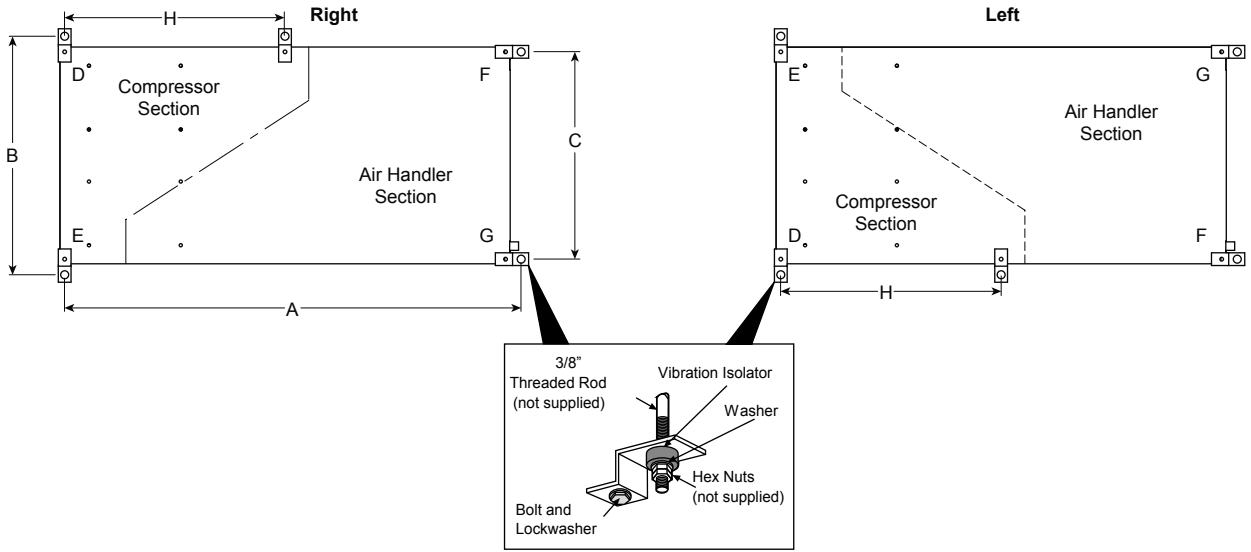

NOTE: Model sizes 070-072 will be shipped with six (6) hanger brackets. Only five (5) hanger brackets will be used on the unit. See the above illustration for the fifth hanger bracket location. All other models will use four (4) hanger brackets.

Hanger Bracket Dimensions

	Model		Hanger Kit Part Number	Unit Hanger Dimensions			
				A	B	C	H
Single Speed	009-012	in.	99S500A04	35.7	25.1	21.4	n/a
		cm.		90.7	63.8	54.4	n/a
	015-018	in.	99S500A04	42.8	25.1	21.4	n/a
		cm.		108.7	63.8	54.4	n/a
	024-030	in.	99S500A04	45.8	25.1	21.4	n/a
		cm.		116.3	63.8	54.4	n/a
	036	in.	99S500A04	48.8	28.1	24.4	n/a
		cm.		124.0	71.4	62.0	n/a
	042-048	in.	99S500A04	53.8	28.1	24.4	n/a
		cm.		136.7	71.4	62.0	n/a
060	in.	99S500A04	61.8	28.1	24.4	n/a	
	cm.		157.0	71.4	62.0	n/a	
070	in.	99S500A03	68.8	28.1	24.4	34.0	
	cm.		174.8	71.4	62.0	74.4	
Dual Capacity	026	in.	99S500A04	45.8	25.1	21.4	n/a
		cm.		116.3	63.8	54.4	n/a
	038	in.	99S500A03	48.8	28.1	24.4	n/a
		cm.		124.0	71.4	62.0	n/a
	049	in.	99S500A04	53.8	28.1	24.4	n/a
		cm.		136.7	71.4	62.0	n/a
	064	in.	99S500A04	61.8	28.1	24.4	n/a
		cm.		157.0	71.4	62.0	n/a
	072	in.	99S500A03	68.8	28.1	24.4	34.0
		cm.		174.8	71.4	62.0	74.4

3/16/12

Weight Distribution

	Model	Vertical Weight	Horizontal Weight	Horizontal Weight Distribution			
				Front		Back	
				D	E	F	G
Single Speed	009	171	176	32	67	32	45
		[78]	[80]	[15]	[30]	[15]	[20]
	012	171	176	32	67	32	45
		[78]	[80]	[15]	[30]	[15]	[20]
	015	210	220	65	40	70	35
		[95]	[100]	[29]	[18]	[32]	[16]
	018	210	220	65	40	70	35
		[95]	[100]	[29]	[18]	[32]	[16]
	024	280	295	75	70	75	20
		[127]	[134]	[34]	[31]	[34]	[13]
030	285	295	75	70	75	30	
	[129]	[134]	[34]	[31]	[34]	[13]	
036	300	305	85	80	85	40	
	[136]	[138]	[39]	[36]	[39]	[18]	
042	365	375	115	95	75	60	
	[166]	[170]	[52]	[43]	[34]	[27]	
048	370	380	120	100	80	65	
	[168]	[172]	[54]	[45]	[36]	[29]	
060	410	420	120	110	95	80	
	[186]	[191]	[54]	[50]	[43]	[36]	
070	445	455	135	120	100	85	
	[202]	[206]	[61]	[54]	[45]	[39]	
Dual Capacity	026	280	295	75	70	75	50
		[127]	[134]	[34]	[31]	[34]	[13]
	038	360	375	115	95	75	60
		[163]	[170]	[52]	[43]	[34]	[27]
	049	370	380	120	100	80	65
		[168]	[172]	[54]	[45]	[36]	[29]
	064	410	420	120	110	95	80
		[186]	[191]	[54]	[50]	[43]	[36]
	072	445	455	135	120	100	85
		[202]	[206]	[61]	[54]	[45]	[39]

Weights are listed in lbs. [kg].

3/16/12

Duct System

An air outlet collar is provided on vertical top flow units and all horizontal units to facilitate a duct connection. A flexible connector is recommended for discharge and return air duct connections on metal duct systems. Uninsulated duct should be insulated with a minimum of 1-inch duct insulation. Application of the unit to uninsulated ductwork in an unconditioned space is not recommended as the unit's performance will be adversely affected.

If the unit is connected to existing ductwork, check the duct system to ensure that it has the capacity to accommodate the air required for the unit application. If the duct is too small, as in the replacement of heating only systems, larger ductwork should be installed. All existing ductwork should be checked for leaks and repaired if necessary.

The duct system should be sized to handle the design airflow quietly and efficiently. To maximize sound attenuation of the unit blower, the supply and return plenums should include an internal duct liner of fiberglass or constructed of ductboard for the first few feet. On systems employing a sheet metal duct system, canvas connectors should be used between the unit and the ductwork. If air noise or excessive airflow is a problem, the blower speed can be changed.

Water Piping

The proper water flow must be provided to each unit whenever the unit operates. To assure proper flow, use pressure/temperature ports to determine the flow rate. These ports should be located at the supply and return water connections on the unit. The proper flow rate cannot be accurately set without measuring the water pressure drop through the refrigerant-to-water heat exchanger.

All source water connections on commercial units are fittings that accept a male pipe thread (MPT). Insert the connectors by hand, then tighten the fitting with a wrench to provide a leakproof joint. When connecting to an open loop (groundwater) system, thread any copper MPT fitting into the connector and tighten in the same manner as described above.

Condensate Drain

On vertical units, the internal condensate drain assembly consists of a drain tube which is connected to the drain pan, a 3/4 in. PVC female adapter and a flexible connecting hose. The female adapter may exit either the front or the side of the cabinet. The adapter should be glued to the field-installed PVC condensate piping. On vertical units, a condensate hose is inside all cabinets as a trapping loop; therefore, an external trap is not necessary.

On horizontal units, a PVC stub or stainless steel tube is provided for condensate drain piping connection. An external trap is required (see below). If a vent is necessary, an open stand pipe may be applied to a tee in the field-installed condensate piping.

Horizontal Drain Connection (Composite Drain Pan)

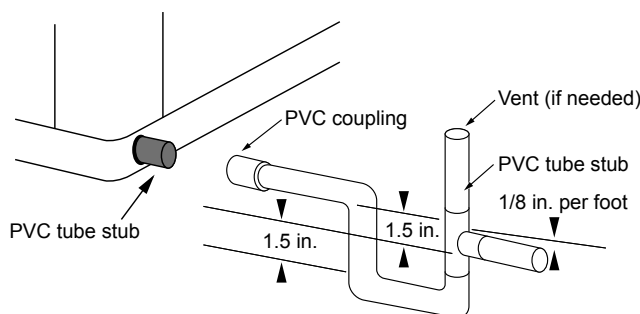

Unit Pitch for Drain

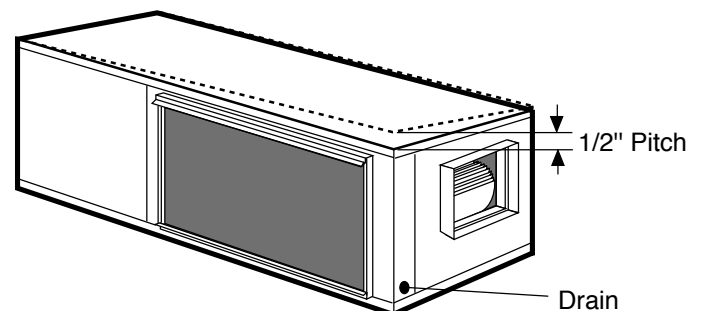

Water Quality

In ground water situations where scaling could be heavy or where biological growth such as iron bacteria will be present, a closed loop system is recommended. The heat exchanger coils in ground water systems may, over a period of time, lose heat exchange capabilities due to a buildup of mineral deposits inside. These can be cleaned, but only by a qualified service mechanic, as special solutions and pumping equipment are required. Hot water generator coils can likewise become scaled and possibly plugged.

In areas with extremely hard water, the owner should be informed that the heat exchanger may require occasional flushing. Failure to adhere to the guidelines in the water quality table could result in loss of warranty.

Units with cupronickel heat exchangers are recommended for open loop applications due to the increased resistance to build-up and corrosion, along with reduced wear caused by acid cleaning.

Material		Copper	90/10 Cupronickel	316 Stainless Steel
pH	Acidity/Alkalinity	7 - 9	7 - 9	7 - 9
Scaling	Calcium and Magnesium Carbonate	(Total Hardness) less than 350 ppm	(Total Hardness) less than 350 ppm	(Total Hardness) less than 350 ppm
Corrosion	Hydrogen Sulfide	Less than 0.5 ppm (rotten egg smell appears at 0.5 ppm)	10 - 50 ppm	Less than 1 ppm
	Sulfates	Less than 125 ppm	Less than 125 ppm	Less than 200 ppm
	Chlorine	Less than 0.5 ppm	Less than 0.5 ppm	Less than 0.5 ppm
	Chlorides	Less than 20 ppm	Less than 125 ppm	Less than 300 ppm
	Carbon Dioxide	Less than 50 ppm	10 - 50 ppm	10 - 50 ppm
	Ammonia	Less than 2 ppm	Less than 2 ppm	Less than 20 ppm
	Ammonia Chloride	Less than 0.5 ppm	Less than 0.5 ppm	Less than 0.5 ppm
	Ammonia Nitrate	Less than 0.5 ppm	Less than 0.5 ppm	Less than 0.5 ppm
	Ammonia Hydroxide	Less than 0.5 ppm	Less than 0.5 ppm	Less than 0.5 ppm
	Ammonia Sulfate	Less than 0.5 ppm	Less than 0.5 ppm	Less than 0.5 ppm
	Total Dissolved Solids (TDS)	Less than 1000 ppm	1000 - 1500 ppm	1000 - 1500 ppm
	LSI Index	+0.5 to -0.5	+0.5 to -0.5	+0.5 to -0.5
Iron Fouling (Biological Growth)	Iron, FE ²⁺ (Ferrous) Bacterial Iron Potential	< 0.2 ppm	< 0.2 ppm	< 0.2 ppm
	Iron Oxide	Less than 1 ppm, above this level deposition will occur	Less than 1 ppm, above this level deposition will occur	Less than 1 ppm, above this level deposition will occur
Erosion	Suspended Solids	Less than 10 ppm and filtered for max. of 600 micron size	Less than 10 ppm and filtered for max. of 600 micron size	Less than 10 ppm and filtered for max. of 600 micron size
	Threshold Velocity (Fresh Water)	< 6 ft/sec	< 6 ft/sec	< 6 ft/sec

NOTES: Grains = ppm divided by 17
mg/L is equivalent to ppm

2/22/12

System Cleaning and Flushing

Cleaning and Flushing

Prior to start up of any heat pump, the water circulating system must be cleaned and flushed of all dirt and debris.

If the system is equipped with water shutoff valves, the supply and return runouts must be connected together at each unit location (This will prevent the introduction of dirt into the unit, see Flushing with Water Shutoff Valve Equipped Systems illustration). The system should be filled at the water make-up connection with all air vents open. After filling, vents should be closed.

The contractor should start the main circulator with the pressure reducing valve makeup open. Vents should be checked in sequence to bleed off any trapped air and to verify circulation through all components of the system.

As water circulates through the system, the contractor should check and repair any leaks found in the piping system. Drain(s) at the lowest point(s) in the system should be opened for initial flush and blowdown, making sure water fill valves are set at the same rate. Check the pressure gauge at the pump suction and manually

Flushing with Water Shutoff Valve Equipped Systems

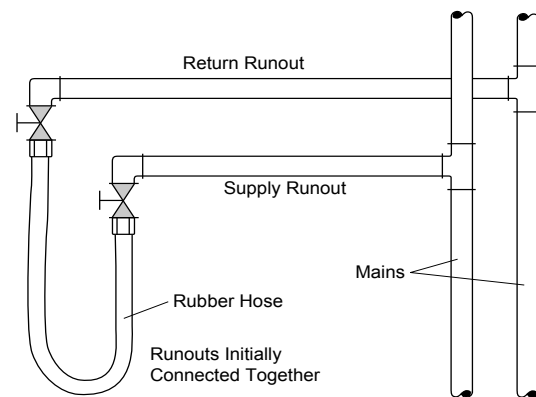

System Cleaning and Flushing cont.

adjust the make-up water valve to hold the same positive pressure both before and after opening the drain valves. Flushing should continue for at least two hours, or longer if required, until drain water is clean and clear.

The supplemental heater and/or circulator pump, if used, should be shut off. All drains and vents should be opened to completely drain the system. Short-circuited supply and return runouts should now be connected to the unit supply and return connections.

Refill the system with clean water. Test the system water for acidity and treat as required to leave the water slightly alkaline (pH 7.5 to 8.5). The specified percentage of antifreeze may also be added at this time. Use commercial grade antifreeze designed for HVAC systems only. Environol™ brand antifreeze is recommended.

Once the system has been filled with clean water and antifreeze (if used), precautions should be taken to protect the system from dirty water conditions. Dirty water will result in system-wide degradation of performance, and solids may clog valves, strainers, flow regulators, etc. Additionally, the heat exchanger may become clogged which reduces compressor service life and can cause premature unit failure.

In boiler/tower application, set the loop control panel set points to desired temperatures. Supply power to all motors and start the circulating pumps. After full flow has been established through all components including the heat rejector (regardless of season), air vented and loop temperatures stabilized, each of the units will be ready for check, test and start up and for air and water balancing.

Ground Source Loop System Checkout

Once piping is completed between the unit pumping system and ground loop, final purging and charging of the loop is needed. A high pressure pump is needed to achieve adequate flow velocity in the loop to purge air and dirt particles from the loop itself. Antifreeze solution is used in most areas to prevent freezing. Flush the system adequately to remove as much air as possible; then pressurize the loop to a static pressure of 40-50 PSI (summer) or 50-75 PSI (winter). This is normally adequate for good system operation. Loop static pressure may decrease soon after initial installation, due to pipe expansion and loop temperature change. Running the unit for at least 30 minutes after the system has been completely purged of air will allow for the "break-in" period. It may be necessary to adjust static loop pressure (by adding water) after the unit has run for the first time. Loop static pressure will also fluctuate with the seasons. Pressures will be higher in the winter months than during the cooling season. This fluctuation is normal and should be considered when charging the system initially.

Ensure the pump provides adequate flow through the unit by checking pressure drop across the heat exchanger. Usually 2.25-3.0 gpm of flow per ton of cooling capacity is recommended in earth loop applications.

Open Loop Ground Water Systems

Typical open loop piping is shown below. Always maintain water pressure in the heat exchanger by placing water control valves at the outlet of the unit to prevent mineral precipitation. Use a closed, bladder-type expansion tank to minimize mineral formation due to air exposure. Insure proper water flow through the unit by checking pressure drop across the heat exchanger and comparing it to the figures in unit capacity data tables in the specification catalog. 1.5-2 gpm of flow per ton of cooling capacity is recommended in open loop applications. Due to only minor differences in flow rate from low to high, only one solenoid valve should be used. The valve should be sized for full flow.

Discharge water from the unit is not contaminated in any manner and can be disposed of in various ways, depending on local codes, i.e. recharge well, storm sewer, drain field, adjacent stream or pond, etc. Most local codes forbid the use of sanitary sewer for disposal. Consult your local building and zoning departments to assure compliance in your area.

Open System - Groundwater Application

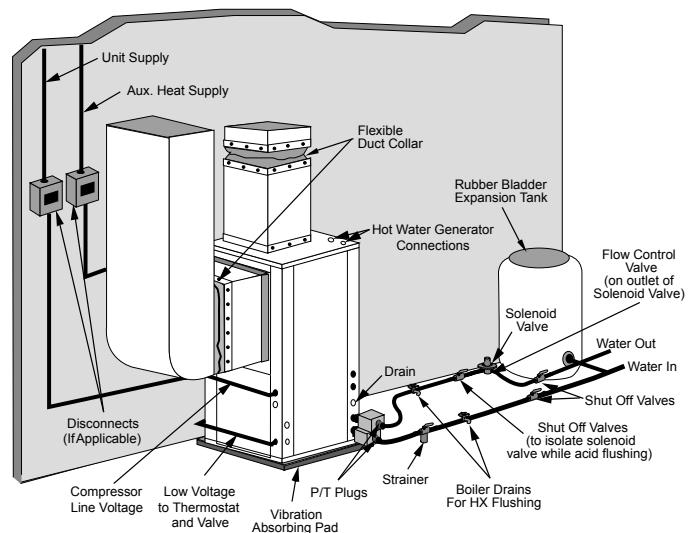

Hot Water Generator Connections

The heat reclaiming hot water generator coil is of vented double-wall copper construction and is suitable for potable water.

To maximize the benefits of the hot water generator a minimum 50-gallon water heater is recommended. For higher demand applications, use an 80-gallon water heater or two 50-gallon water heaters connected in a series as shown below. Electric water heaters are recommended. Make sure all local electrical and plumbing codes are met for installing a hot water generator. A water softener is recommended with hard water (greater than 10 grains or 170 total hardness).

Water Tank Preparation

To install a unit with a hot water generator, follow these installation guidelines.

1. Turn off the power to the water heater.
2. Attach a water hose to the water tank drain connection and run the other end of the hose to an open drain or outdoors.
3. Close the cold water inlet valve to the water heater tank.
4. Drain the tank by opening the valve on the bottom of the tank, then open the pressure relief valve or hot water faucet.
5. Flush the tank by opening the cold water inlet valve to the water heater to free the tank of sediments. Close when draining water is clear.
6. Disconnect the garden hose and remove the drain valve from the water heater.
7. Refer to Plumbing Installation and Hot Water Generator Startup.

Plumbing Installation

1. Inspect the dip tube in the water heater cold inlet for a check valve. If a check valve is present it must be removed or damage to the hot water generator circulator will occur.
2. Remove drain valve and fitting.
3. Thread the 3/4-inch NPT x 3-1/2-inch brass nipple into the water heater drain port.
4. Attach the center port of the 3/4-inch FPT tee to the opposite end of the brass nipple.
5. Attach the 1/2-inch copper to 3/4-inch NPT adaptor to the side of the tee closest to the unit.
6. Install the drain valve on the tee opposite the adaptor.
7. Run interconnecting tubing from the tee to HWG water out.
8. Cut the cold water "IN" line going to the water heater.

Typical Hot Water Generator Installation

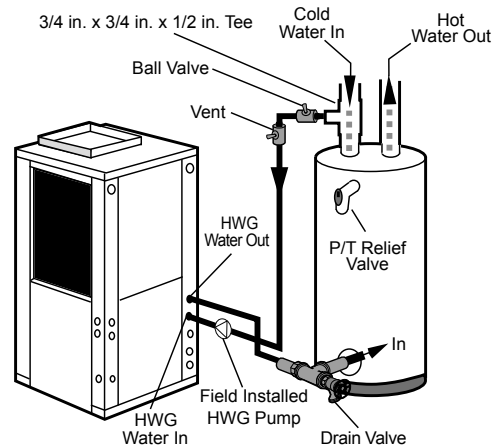

Hot Water Generator Installation In Preheat Tank

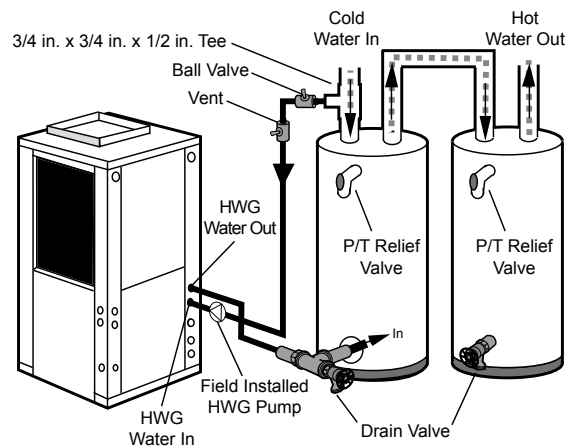

NOTE: This configuration maximizes hot water generator capability.



CAUTION: Elements will burn out if energized dry.

9. Insert the reducing solder tee in line with cold water "IN" line as shown.
10. Run interconnecting copper tubing between the unit DHW water "IN" and the tee (1/2-inch nominal). The recommended maximum distance is 50 feet.
11. To prevent air entrapment in the system, install a vent coupling at the highest point of the interconnecting lines.
12. Insulate all exposed surfaces of both connecting water lines with 3/8-inch wall closed cell insulation.

NOTE: All plumbing and piping connections must comply with local plumbing codes.

Hot Water Generator Connections cont.

Hot Water Generator Startup

1. Make sure the power is off to the heat pump. Connect the wire from the hot water generator pump to T1 on the contactor.
2. Close the drain valve to the water heater.
3. Open the cold water supply to the tank.
4. Open a hot water faucet in the building to bleed air from the system. Close when full.
5. Open the pressure relief valve to bleed any remaining air from the tank, then close.
6. If so equipped, turn the venting (burping) screw in the center of the pump two (2) turns open (water will drip out), wait until all air is purged from the pump, then tighten the plug. Use vent couplings to bleed air from the lines.
7. Carefully inspect all plumbing for water leaks and correct as required.
8. Before restoring electrical supply to the water heater, adjust the temperature setting on the tank.
 - On tanks with both upper and lower elements, the lower element should be turned down to the lowest setting, approximately 100°F. The upper element should be adjusted to 120°F to 130°F. Depending upon the specific needs of the customer, you may want to adjust the upper element differently.
 - On tanks with a single element, lower the thermostat setting to 120°F.
9. After the thermostat(s) is adjusted, replace the access cover and restore electrical supply to the water heater.

10. Make sure that any valves in the hot water generator circuit are open.
11. Turn on the unit to heating.
12. The HWG pump should be running. When the pump is first started, turn the venting (burping) screw (if equipped) in the center of the pump two (2) turns open until water dribbles out, then replace. Allow the pump to run for at least five minutes to ensure that water has filled the circulator properly.
13. The temperature difference between the water entering and leaving the hot water generator should be 5°F to 15°F. The water flow should be approximately 0.4 gpm per ton of nominal cooling.
14. Allow the unit to heat water for 15 to 20 minutes to be sure operation is normal.



CAUTION: Never operate the HWG circulating pump while dry. If the unit is placed in operation before the hot water generator piping is connected, be sure that the pump wires are disconnected from the contactor.

Freeze Detection

For Aurora Base Control, set SW2-1, FP1, on the printed circuit board for applications using a closed loop antifreeze solution to 15°F [-9.4°C]. On applications using an open loop/ground water system (or closed loop no antifreeze), set this dip switch to 30°F [-1.1°C], the factory default setting. (Refer to the Dip Switch Field Selection table).

For FX10 board, the “red” wire must be removed from PB2-3 to change from 30°F [-1.1°C], the factory default setting, to 15°F [-9.4°C].

Electrical Connections

General

Be sure the available power is the same voltage and phase as that shown on the unit serial plate. Line and low voltage wiring must be done in accordance with local codes or the National Electric Code, whichever is applicable.

Power Connection

Connect the incoming line voltage wires to L1 and L2 of the contactor for single-phase unit. Consult the Electrical Data tables for correct fuse sizes.

208 Volt Operation

All 208/230 units are factory wired for 230 volt operation. For 208 volt operation, the red and blue transformer wires must be switched on terminal strip PS.



CAUTION: When installing a unit with a variable speed ECM blower motor in 460/60/3 voltage, a neutral wire is required to allow proper unit operation.

Aurora Base Control Box

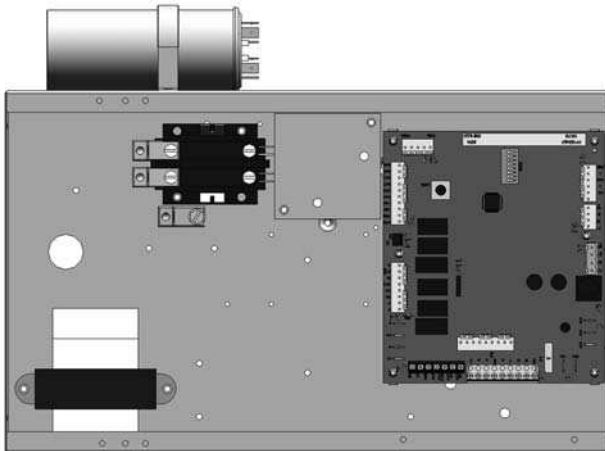

FX10 Control Box

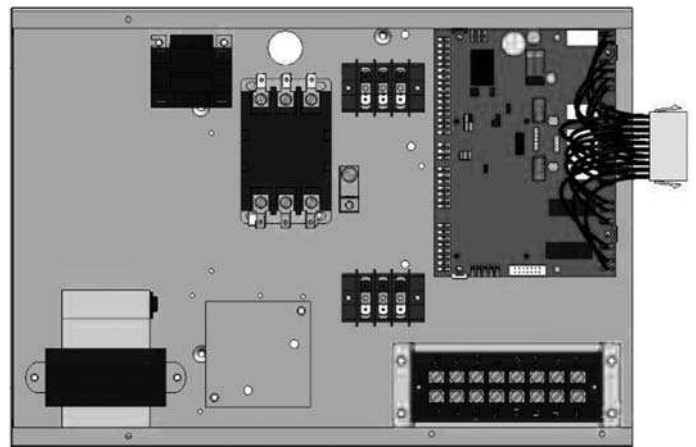

Electrical Data

PSC Motor

Model	Rated Voltage	Voltage Min/Max	Compressor				Blower Motor FLA	Total Unit FLA	Min Circ Amp	Max Fuse/ HACR Breaker	
			MCC	RLA	LRA	LRA**					
Single Speed	009	208-230/60/1	187/253	6.4	4.1	21.0	n/a	0.6	4.7	5.7	10/15
		265/60/1	238/292	6.7	4.3	22.0	n/a	0.6	4.9	6.0	10/15
	012	208-230/60/1	187/253	7.7	4.9	25.0	n/a	0.6	5.5	6.7	10/15
		265/60/1	238/292	7.0	4.5	22.0	n/a	0.6	5.1	6.2	10/15
	015	208-230/60/1	187/253	9.7	6.2	29.0	n/a	1.1	7.3	8.9	15
		265/60/1	238/292	7.8	5.0	28.0	n/a	1.0	6.0	7.3	10/15
	018	208-230/60/1	187/253	13.1	8.4	33.5	n/a	1.1	9.5	11.6	20
		265/60/1	238/292	8.7	5.6	28.0	n/a	1.0	6.6	8.0	10/15
	024	208-230/60/1	187/253	21.0	13.5	58.3	17.0	1.2	14.7	18.1	25
		265/60/1	238/292	14.0	9.0	54.0	n/a	1.1	10.1	12.4	20
		208-230/60/3	187/253	11.0	7.1	55.4	33.2	1.2	8.3	10.1	15
		460/60/3	414/506	5.5	3.5	28.0	16.8	0.6	4.1	5.0	10/15
	024*	208-230/60/1	187/253	21.0	13.5	58.3	17.0	1.5	15.0	18.4	30
		265/60/1	238/292	14.0	9.0	54.0	n/a	1.5	10.5	12.8	20
		208-230/60/3	187/253	11.0	7.1	55.4	33.2	1.5	8.6	10.4	15
		460/60/3	414/506	5.5	3.5	28.0	16.8	1.0	4.5	5.4	10/15
	030	208-230/60/1	187/253	20.0	12.8	58.0	21.0	1.5	14.3	17.5	30
		265/60/1	238/292	15.0	9.6	54.0	n/a	1.5	11.1	13.5	20
		208-230/60/3	187/253	12.0	7.7	55.4	33.2	1.5	9.2	11.1	15
		460/60/3	414/506	5.6	3.6	28.0	16.8	1.0	4.6	5.5	10/15
	030*	208-230/60/1	187/253	20.0	12.8	58.0	21.0	2.8	15.6	18.8	30
		265/60/1	238/292	15.0	9.6	54.0	n/a	2.0	11.6	14.0	20
		208-230/60/3	187/253	12.0	7.7	55.4	33.2	2.2	9.9	11.8	15
		460/60/3	414/506	5.6	3.6	28.0	16.8	1.1	4.7	5.6	10/15
	036	208-230/60/1	187/253	22.0	14.1	73.0	26.0	2.8	16.9	20.4	30
		265/60/1	238/292	17.5	11.2	60.0	n/a	2.0	13.2	16.0	25
		208-230/60/3	187/253	13.9	8.9	58.0	34.8	2.8	11.7	13.9	20
		460/60/3	414/506	6.5	4.2	28.0	16.8	1.4	5.6	6.7	10/15
036*	208-230/60/1	187/253	22.0	14.1	73.0	26.0	3.5	17.6	21.1	35	
	265/60/1	238/292	17.5	11.2	60.0	n/a	3.5	14.7	17.5	25	
	208-230/60/3	187/253	13.9	8.9	58.0	34.8	1.8	10.7	12.9	20	
	460/60/3	414/506	6.5	4.2	28.0	16.8	1.4	5.6	6.7	10/15	
042	208-230/60/1	187/253	26.0	16.7	79.0	28.0	3.5	20.2	24.4	40	
	208-230/60/3	187/253	16.3	10.4	73.0	43.8	3.5	13.9	16.5	25	
	460/60/3	414/506	9.0	5.8	38.0	22.8	1.8	7.6	9.0	10/15	
	575/60/3	517/633	5.9	3.8	36.5	n/a	1.4	5.2	6.1	10/15	
042*	208-230/60/1	187/253	26.0	16.7	79.0	28.0	4.6	21.3	25.5	40	
	208-230/60/3	187/253	16.3	10.4	73.0	43.8	4.6	15.0	17.6	25	
	460/60/3	414/506	9.0	5.8	38.0	22.8	2.3	8.1	9.5	15	
	575/60/3	517/633	5.9	3.8	36.5	n/a	1.9	5.7	6.6	10/15	
048	208-230/60/1	187/253	31.0	19.9	109.0	38.0	3.5	23.4	28.4	45	
	208-230/60/3	187/253	21.2	13.6	83.1	49.9	3.5	17.1	20.5	30	
	460/60/3	414/506	9.5	6.1	41.0	24.6	1.8	7.9	9.4	15	
	575/60/3	517/633	6.5	4.2	33.0	n/a	1.4	5.6	6.7	10/15	
048*	208-230/60/1	187/253	31.0	19.9	109.0	38.0	4.6	24.5	29.5	45	
	208-230/60/3	187/253	21.2	13.6	83.1	49.9	4.6	18.2	21.6	35	
	460/60/3	414/506	9.5	6.1	41.0	24.6	2.3	8.4	9.9	15	
	575/60/3	517/633	6.5	4.2	33.0	n/a	1.9	6.1	7.2	10/15	
060	208-230/60/1	187/253	41.2	26.4	134.0	47.0	5.9	32.3	38.9	60	
	208-230/60/3	187/253	24.9	16.0	110.0	66.0	5.9	21.9	25.9	40	
	460/60/3	414/506	12.1	7.8	52.0	31.2	3.0	10.8	12.8	20	
	575/60/3	517/633	8.9	5.7	38.9	n/a	1.9	7.6	9.0	10/15	
070	208-230/60/1	187/253	44.2	28.3	178.0	55.0	5.9	34.2	41.3	70	
	208-230/60/3	187/253	30.0	19.2	136.0	81.6	5.9	25.1	29.9	45	
	460/60/3	414/506	13.6	8.7	66.1	39.7	3.0	11.7	13.9	20	
	575/60/3	517/633	10.7	6.9	55.3	n/a	1.9	8.8	10.5	15	

1/2/2013

HACR circuit breaker in USA only
 *With optional High-static PSC motor
 **With optional GeoStart

Electrical Data cont.

5-Speed ECM Motor

Model	Rated Voltage	Voltage Min/Max	Compressor				Blower Motor FLA	Total Unit FLA	Min Circ Amp	Max Fuse/ HACR Breaker		
			MCC	RLA	LRA	LRA**						
Single Speed	015	208-230/60/1	187/253	9.7	6.2	29.0	n/a	4.1	10.3	11.9	15	
		265/60/1	238/292	7.8	5.0	28.0	n/a	3.6	8.6	9.9	10/15	
	018	208-230/60/1	187/253	13.1	8.4	33.5	n/a	4.1	12.5	14.6	20	
		265/60/1	238/292	8.7	5.6	28.0	n/a	3.6	9.2	10.6	15	
	024	208-230/60/1	187/253	21.0	13.5	58.3	21.0	4.1	17.6	21.0	30	
		265/60/1	238/292	14.0	9.0	54.0	n/a	3.6	12.6	14.9	20	
		208-230/60/3	187/253	11.0	7.1	55.4	33.2	4.1	11.2	13.0	20	
	030	460/60/3	414/506	5.5	3.5	28.0	16.8	2.1	5.6	6.5	10/15	
		208-230/60/1	187/253	20.0	12.8	58.0	26.0	4.1	16.9	20.1	30	
		265/60/1	238/292	15.0	9.6	54.0	n/a	3.6	13.2	15.6	25	
		208-230/60/3	187/253	12.0	7.7	55.4	33.2	4.1	11.8	13.7	20	
	036	460/60/3	414/506	5.6	3.6	28.0	16.8	2.1	5.7	6.6	10/15	
		208-230/60/1	187/253	22.0	14.1	73.0	34.0	4.1	18.2	21.7	35	
		265/60/1	238/292	17.5	11.2	60.0	n/a	3.6	14.8	17.6	25	
		208-230/60/3	187/253	13.9	8.9	58.0	34.8	4.1	13.0	15.2	20	
	042	460/60/3	414/506	6.5	4.2	28.0	16.8	2.1	6.3	7.4	10/15	
		208-230/60/1	187/253	26.0	16.7	79.0	41.0	7.6	24.3	28.5	45	
		208-230/60/3	187/253	16.3	10.4	73.0	43.8	7.6	18.0	20.6	30	
	048	460/60/3	414/506	9.0	5.8	38.0	22.8	4.0	9.8	11.2	15	
		208-230/60/1	187/253	31.0	19.9	109.0	41.0	7.6	27.5	32.5	50	
		208-230/60/3	187/253	21.2	13.6	83.1	49.9	7.6	21.2	24.6	35	
	060	460/60/3	414/506	9.5	6.1	41.0	24.6	4.0	10.1	11.6	15	
		208-230/60/1	187/253	41.2	26.4	134.0	53.0	7.6	34.0	40.6	60	
		208-230/60/3	187/253	24.9	16.0	110.0	66.0	7.6	23.6	27.6	40	
070	460/60/3	414/506	12.1	7.8	52.0	31.2	4.0	11.8	13.8	20		
	208-230/60/1	187/253	44.2	28.3	178.0	51.0	7.6	35.9	43.0	70		
	208-230/60/3	187/253	30.0	19.2	136.0	81.6	7.6	26.8	31.6	50		
Dual Capacity	026	460/60/3	414/506	13.6	8.7	66.1	39.7	4.0	12.7	14.9	20	
		208-230/60/1	187/253	18.2	11.7	58.3	21.0	4.1	15.8	18.7	30	
		265/60/1	238/292	14.2	9.1	54.0	n/a	3.6	12.7	15.0	20	
		208-230/60/3	187/253	10.1	6.5	55.4	33.2	4.1	10.6	12.2	15	
	038	460/60/3	414/506	5.4	3.5	28.0	16.8	2.1	5.6	6.4	10/15	
		208-230/60/1	187/253	23.8	15.3	83.0	30.0	4.1	19.4	23.2	35	
		265/60/1	238/292	20.3	13.0	72.0	n/a	3.6	16.6	19.9	30	
		208-230/60/3	187/253	18.1	11.6	73.0	43.8	4.1	15.7	18.6	30	
	049	460/60/3	414/506	8.9	5.7	38.0	22.8	2.1	7.8	9.2	10/15	
		208-230/60/1	187/253	33.0	21.1	104.0	37.0	7.6	28.7	34.0	50	
		208-230/60/3	187/253	21.9	14.0	83.1	49.9	7.6	21.6	25.1	35	
	064	460/60/3	414/506	10.0	6.4	41.0	24.6	4.0	10.4	12.0	15	
		208-230/60/1	187/253	42.3	27.1	152.9	54.0	7.6	34.7	41.5	60	
		208-230/60/3	187/253	25.8	16.5	110.0	66.0	7.6	24.1	28.2	40	
	072	460/60/3	414/506	11.3	7.2	52.0	31.2	4.0	11.2	13.0	20	
		208-230/60/1	187/253	46.3	29.7	179.2	63.0	7.6	37.3	44.7	70	
		208-230/60/3	187/253	27.4	17.6	136.0	81.6	7.6	25.2	29.6	45	
			460/60/3	414/506	13.2	8.5	66.1	39.7	4.0	12.5	14.6	20

HACR circuit breaker in USA only

**With optional GeoStart

1/2/2013

Electrical Data cont.

Variable Speed ECM Motor

Model	Rated Voltage	Voltage Min/Max	Compressor				Blower Motor FLA	Total Unit FLA	Min Circ Amp	Max Fuse/HACR Breaker	
			MCC	RLA	LRA	LRA**					
Single Speed	015	208-230/60/1	187/253	9.7	6.2	29.0	n/a	4.0	10.2	11.8	15
		265/60/1	238/292	7.8	5.0	28.0	n/a	4.1	9.1	10.4	15
	018	208-230/60/1	187/253	13.1	8.4	33.5	n/a	4.0	12.4	14.5	20
		265/60/1	238/292	8.7	5.6	28.0	n/a	4.1	9.7	11.1	15
	024	208-230/60/1	187/253	21.0	13.5	58.3	17.0	4.0	17.5	20.9	30
		265/60/1	238/292	14.0	9.0	54.0	n/a	4.1	13.1	15.4	20
		208-230/60/3	187/253	11.0	7.1	55.4	33.2	4.0	11.1	12.9	20
	030	460/60/3	414/506	5.5	3.5	28.0	16.8	4.1	7.6	8.5	10/15
		208-230/60/1	187/253	20.0	12.8	58.0	21.0	4.0	16.8	20.0	30
		265/60/1	238/292	15.0	9.6	54.0	n/a	4.1	13.7	16.1	25
		208-230/60/3	187/253	12.0	7.7	55.4	33.2	4.0	11.7	13.6	20
	036	460/60/3	414/506	5.6	3.6	28.0	16.8	4.1	7.7	8.6	10/15
		208-230/60/1	187/253	22.0	14.1	73.0	26.0	4.0	18.1	21.6	35
		265/60/1	238/292	17.5	11.2	60.0	n/a	4.1	15.3	18.1	25
		208-230/60/3	187/253	13.9	8.9	58.0	34.8	4.0	12.9	15.1	20
	036*	460/60/3	414/506	6.5	4.2	28.0	16.8	4.1	8.3	9.4	10/15
		208-230/60/1	187/253	22.0	14.1	73.0	26.0	7.0	21.1	24.6	35
		265/60/1	238/292	17.5	11.2	60.0	n/a	6.9	18.1	20.9	30
		208-230/60/3	187/253	13.9	8.9	58.0	34.8	7.0	15.9	18.1	25
	042	460/60/3	414/506	6.5	4.2	28.0	16.8	6.9	11.1	12.2	15
		208-230/60/1	187/253	26.0	16.7	79.0	28.0	4.0	20.7	24.9	40
		208-230/60/3	187/253	16.3	10.4	73.0	43.8	4.0	14.4	17.0	25
	042*	460/60/3	414/506	9.0	5.8	38.0	22.8	4.1	9.9	11.3	15
		208-230/60/1	187/253	26.0	16.6	79.0	28.0	7.0	23.6	27.8	40
208-230/60/3		187/253	16.3	10.4	73.0	43.8	7.0	17.4	20.0	30	
048	460/60/3	414/506	9.0	5.8	38.0	22.8	6.9	12.7	14.1	15	
	208-230/60/1	187/253	31.0	19.9	109.0	38.0	4.0	23.9	28.9	45	
	208-230/60/3	187/253	21.2	13.6	83.1	49.9	4.0	17.6	21.0	30	
	460/60/3	414/506	9.5	6.1	41.0	24.6	4.1	10.2	11.7	15	
048*	208-230/60/1	187/253	31.0	19.9	109.0	38.0	7.0	26.9	31.9	50	
	208-230/60/3	187/253	21.2	13.6	83.1	49.9	7.0	20.6	24.0	35	
	460/60/3	414/506	9.5	6.1	41.0	24.6	6.9	13.0	14.5	20	
060	208-230/60/1	187/253	41.2	26.4	134.0	47.0	7.0	33.4	40.0	60	
	208-230/60/3	187/253	24.9	16.0	110.0	66.0	7.0	23.0	27.0	40	
	460/60/3	414/506	12.1	7.8	52.0	31.2	6.9	14.7	16.7	20	
070	208-230/60/1	187/253	44.2	28.3	178.0	55.0	7.0	35.3	42.4	70	
	208-230/60/3	187/253	30.0	19.2	136.0	81.6	7.0	26.2	31.0	50	
	460/60/3	414/506	13.6	8.7	66.1	39.7	6.9	15.6	17.8	25	
Dual Capacity	026	208-230/60/1	187/253	18.2	11.7	58.3	18.0	4.0	15.7	18.6	30
		265/60/1	238/292	14.2	9.1	54.0	n/a	4.1	13.2	15.5	20
		208-230/60/3	187/253	10.1	6.5	55.4	33.2	4.0	10.5	12.1	15
		460/60/3	414/506	5.4	3.5	28.0	16.8	4.1	7.6	8.4	10/15
	038	208-230/60/1	187/253	23.8	15.3	83.0	29.0	4.0	19.3	23.1	35
		265/60/1	238/292	20.3	13.0	72.0	n/a	4.1	17.1	20.4	30
		208-230/60/3	187/253	18.1	11.6	73.0	43.8	4.0	15.6	18.5	30
		460/60/3	414/506	8.9	5.7	38.0	22.8	4.1	9.8	11.2	15
	038*	208-230/60/1	187/253	23.8	15.3	83.0	29.0	7.0	22.3	26.1	40
		265/60/1	238/292	20.3	13.0	72.0	n/a	7.0	20.0	16.3	25
		208-230/60/3	187/253	18.1	11.6	73.0	43.8	7.0	18.6	21.5	30
		460/60/3	414/506	8.9	5.7	38.0	22.8	6.9	12.6	14.0	15
	049	208-230/60/1	187/253	33.0	21.1	104.0	34.0	4.0	25.1	30.4	50
		208-230/60/3	187/253	21.9	14.0	83.1	49.9	4.0	18.0	21.5	35
		460/60/3	414/506	10.0	6.4	41.0	24.6	4.1	10.5	12.1	15
	049*	208-230/60/1	187/253	33.0	21.1	104.0	34.0	7.0	28.1	33.4	50
		208-230/60/3	187/253	21.9	14.0	83.1	49.9	7.0	21.0	24.5	35
		460/60/3	414/506	10.0	6.4	41.0	24.6	6.9	13.3	14.9	20
	064	208-230/60/1	187/253	42.3	27.1	152.9	41.0	7.0	34.1	40.9	60
		208-230/60/3	187/253	25.8	16.5	110.0	66.0	7.0	23.5	27.6	40
		460/60/3	414/506	11.3	7.2	52.0	31.2	6.9	14.1	15.9	20
	072	208-230/60/1	187/253	46.3	29.7	179.2	53.0	7.0	36.7	44.1	70
		208-230/60/3	187/253	27.4	17.6	136.0	81.6	7.0	24.6	29.0	45
			460/60/3	414/506	13.2	8.5	66.1	39.7	6.9	15.4	17.5

1/2/2013

HACR circuit breaker in USA only
 *With optional 1 HP variable speed ECM motor
 **With optional GeoStart



CAUTION: When installing a unit with a variable speed ECM blower motor in 460/60/3 voltage, a neutral wire is required to allow proper unit operation.

Blower Performance Data

Standard PSC Motor

Model	Blower Spd	Blower Size	Motor HP	Airflow (cfm) at External Static Pressure (in. wg)																
				0	0.05	0.10	0.15	0.20	0.25	0.30	0.35	0.40	0.45	0.50	0.60	0.70	0.80	0.90	1.00	
009	H	6 x 8	1/10	480	450	440	420	410	380	360	340	330	310	300	-	-	-	-	-	
	MH*			440	410	400	380	370	350	330	310	300	280	270	-	-	-	-	-	
	ML*			395	370	360	340	330	310	290	280	270	250	240	-	-	-	-	-	
	L			325	310	300	280	270	250	240	230	220	210	200	-	-	-	-	-	
012	H	6 x 8	1/10	480	450	440	420	410	380	360	340	330	310	300	-	-	-	-	-	
	MH*			440	410	400	380	370	350	330	310	300	280	270	-	-	-	-	-	
	ML*			395	370	360	340	330	310	290	280	270	250	240	-	-	-	-	-	
	L			325	310	300	280	270	250	240	230	220	210	200	-	-	-	-	-	
015	H	9 x 7	1/6	845	835	825	815	800	790	775	755	735	710	680	565	-	-	-	-	
	M			735	730	725	715	705	700	690	675	660	630	600	485	-	-	-	-	
	L			620	615	610	605	600	590	580	565	550	520	490	-	-	-	-	-	
018	H	9 x 7	1/6	845	835	825	815	800	790	775	755	735	710	680	565	-	-	-	-	
	M			735	730	725	715	705	700	690	675	660	630	600	485	-	-	-	-	
	L			620	615	610	605	600	590	580	565	550	520	490	-	-	-	-	-	
024	H	9 x 7	1/5	1085	1055	1030	1005	980	950	925	895	870	830	795	735	555	-	-	-	
	M			915	895	875	855	835	815	795	765	735	705	675	590	520	-	-	-	-
	L			845	830	815	795	775	750	725	702.5	680	650	625	505	-	-	-	-	-
030	H	9 x 7	1/3	1290	1270	1245	1220	1190	1160	1125	1090	1055	1020	985	880	760	-	-	-	
	M			1100	1090	1075	1060	1045	1020	995	970	940	910	875	785	625	-	-	-	-
	L			910	905	900	895	885	875	865	850	835	810	780	710	560	-	-	-	-
036	H	10 x 10	1/2	1665	1640	1610	1580	1550	1515	1480	1450	1415	1315	1215	1090	980	-	-	-	
	M			1465	1445	1425	1400	1375	1350	1325	1260	1190	1140	1090	990	890	-	-	-	-
	L			1130	1115	1100	1090	1075	1035	995	965	930	895	860	795	730	-	-	-	-
042	H	10 x 10	1/2	2010	1975	1940	1905	1870	1825	1780	1735	1690	1640	1590	1470	1210	-	-	-	
	M			1670	1650	1630	1610	1590	1560	1530	1495	1460	1425	1390	1190	1080	-	-	-	-
	L			1220	1215	1210	1295	1200	1180	1160	1130	1100	1060	1020	930	-	-	-	-	-
048	H	10 x 10	1/2	2010	1975	1940	1905	1870	1825	1780	1735	1690	1640	1590	1470	1210	-	-	-	
	M			1670	1650	1630	1610	1590	1560	1530	1495	1460	1425	1390	1190	1080	-	-	-	-
	L			1220	1215	1210	1295	1200	1180	1160	1130	1100	1060	1020	930	-	-	-	-	-
060	H	11 x 10	1	2430	2400	2365	2330	2290	2255	2215	2180	2140	2095	2045	1945	1835	1715	1510	1330	
	M			2265	2235	2205	2175	2145	2110	2070	2035	2000	1960	1915	1825	1730	1605	1440	1260	-
	L			2075	2050	2020	1995	1965	1940	1915	1885	1850	1820	1785	1720	1610	1505	1335	1175	-
070	H	11 x 10	1	2430	2400	2365	2330	2290	2255	2215	2180	2140	2095	2045	1945	1835	1715	1510	1330	
	M			2265	2235	2205	2175	2145	2110	2070	2035	2000	1960	1915	1825	1730	1605	1440	1260	-
	L			2075	2050	2020	1995	1965	1940	1915	1885	1850	1820	1785	1720	1610	1505	1335	1175	-

3/16/12

Optional High Static PSC Motor

Model	Blower Spd	Blower Size	Motor HP	Airflow (cfm) at External Static Pressure (in. wg)																
				0	0.05	0.10	0.15	0.20	0.25	0.30	0.35	0.40	0.45	0.50	0.60	0.70	0.80	0.90	1.00	
024	H	9 x 7	1/3	1290	1270	1245	1220	1190	1160	1125	1090	1055	1020	985	880	760	-	-	-	-
	M			1100	1090	1075	1060	1045	1020	995	970	940	910	875	785	625	-	-	-	-
	L			910	905	900	895	885	875	865	850	835	810	780	710	560	-	-	-	-
030	H	9 x 7	1/2	1365	1340	1325	1305	1280	1250	1215	1180	1140	1100	1055	960	850	-	-	-	-
	M			1040	1040	1035	1030	1020	1005	990	970	945	915	885	810	735	-	-	-	-
	L			880	880	880	880	875	870	860	840	820	800	775	730	480	-	-	-	-
036	H	10 x 10	1/2	1930	1905	1875	1840	1805	1765	1725	1680	1635	1530	1425	1270	1150	1025	-	-	-
	M			1635	1620	1600	1580	1555	1530	1505	1465	1425	1335	1240	1135	1035	775	-	-	-
	L			1230	1230	1225	1215	1200	1165	1130	1095	1060	1035	1005	935	795	675	-	-	-
042	H	10 x 10	3/4	2115	2075	2035	1980	1920	1900	1880	1840	1795	1730	1660	1390	1225	1070	-	-	-
	M			2005	1980	1950	1910	1865	1815	1765	1725	1685	1585	1485	1315	1140	1025	-	-	-
	L			1860	1835	1805	1780	1750	1715	1675	1635	1590	1540	1490	1260	1115	980	-	-	-
048	H	10 x 10	3/4	2115	2075	2035	1980	1920	1900	1880	1840	1795	1730	1660	1390	1225	1070	-	-	-
	M			2005	1980	1950	1910	1865	1815	1765	1725	1685	1585	1485	1315	1140	1025	-	-	-
	L			1860	1835	1805	1780	1750	1715	1675	1635	1590	1540	1490	1260	1115	980	-	-	-

Factory settings are in Bold

3/16/12

Air flow values are with dry coil and 1 in. MERV 4.

For wet coil performance first calculate the face velocity of the air coil (Face Velocity [fpm] = Airflow [cfm] / Face Area [sq ft]).

Then for velocities of 200 fpm reduce the static capability by 0.03 in. wg, 300 fpm by 0.08 in. wg, 400 fpm by 0.12 in. wg, and 500 fpm by 0.16 in. wg.

* Denotes setting for 265 V operation.

Setting Blower Speed - PSC



CAUTION: Disconnect all power before performing this operation.

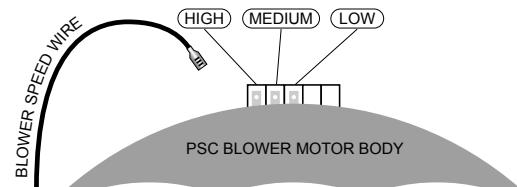

Blower Performance Data cont.

5-Speed ECM - Single Speed

Model	Motor Spd	Motor Tap	T'Stat Cnct.	Blower Size	Motor HP	Airflow (cfm) at External Static Pressure (in. wg)															
						0	0.05	0.10	0.15	0.20	0.25	0.30	0.35	0.40	0.45	0.50	0.60	0.70	0.80	0.90	1.00
015	High	5		9 x 7	1/2	916	898	881	866	851	679	813	804	795	774	754	731	695	643	-	-
	Med High	4	W			809	787	765	754	743	725	707	688	669	654	639	606	536	-	-	-
	Med	3				727	715	703	682	661	638	616	601	587	561	536	485	-	-	-	-
	Med Low	2	Y1			699	675	652	631	611	594	577	551	525	490	455	-	-	-	-	-
	Low	1	G			656	604	552	530	508	493	479	436	394	350	-	-	-	-	-	-
018	High	5		9 x 7	1/2	916	898	881	866	851	679	813	804	795	774	754	731	695	643	-	-
	Med High	4	W			809	787	765	754	743	725	707	688	669	654	639	606	536	-	-	-
	Med	3				727	715	703	682	661	638	616	601	587	561	536	485	-	-	-	-
	Med Low	2	Y1			699	675	652	631	611	594	577	551	525	490	455	-	-	-	-	-
	Low	1	G			656	604	552	530	508	493	479	436	394	350	-	-	-	-	-	-
024	High	5	W	9 x 7	1/2	1015	1003	990	975	955	945	935	920	905	890	880	850	825	745	-	-
	Med High	4	Y1			935	915	895	880	875	855	840	825	815	800	785	755	720	580	-	-
	Med	3				865	855	845	825	810	795	780	765	750	735	720	675	610	570	-	-
	Med Low	2	G			810	790	770	755	740	725	710	695	680	660	640	560	530	-	-	-
	Low	1				695	645	595	575	550	520	495	455	420	400	-	-	-	-	-	-
030	High	5		9 x 7	1/2	1407	1381	1354	1327	1300	1267	1233	1201	1168	1131	1094	1009	-	-	-	-
	Med High	4	W			1146	1134	1122	1111	1099	1085	1071	1062	1052	1042	1031	966	-	-	-	-
	Med	3	Y1			1023	1012	1001	985	969	959	949	937	925	913	901	-	-	-	-	-
	Med Low	2				978	962	946	934	922	907	891	882	872	858	843	-	-	-	-	-
	Low	1	G			795	777	759	748	737	718	698	686	673	650	626	-	-	-	-	-
036	High	5	W	11 x 10	1/2	1530	1503	1476	1453	1429	1413	1397	1376	1355	1342	1329	1276	1231	1173	-	-
	Med High	4	Y1			1413	1388	1363	1342	1321	1303	1285	1263	1240	1226	1212	1173	1016	946	-	-
	Med	3				1355	1325	1294	1276	1258	1235	1212	1188	1164	1144	1123	982	909	883	-	-
	Med Low	2				1336	1299	1261	1242	1222	1202	1181	1157	1132	1111	1090	937	874	830	-	-
	Low	1	G			1243	1182	1121	1061	1000	964	928	856	784	744	703	647	592	-	-	-
042	High	5		11 x 10	1	1934	1910	1886	1871	1855	1827	1799	1780	1760	1747	1734	1700	1659	1617	-	-
	Med High	4	W			1799	1783	1767	1744	1720	1693	1666	1649	1631	1617	1603	1560	1530	1492	-	-
	Med	3				1694	1680	1666	1642	1617	1592	1567	1552	1537	1519	1500	1453	1421	1372	-	-
	Med Low	2	Y1			1575	1560	1540	1520	1502	1487	1471	1448	1424	1409	1393	1351	1308	1266	-	-
	Low	1	G			1454	1406	1358	1333	1308	1285	1261	1239	1217	1198	1179	1072	1002	988	-	-
048	High	5		11 x 10	1	1934	1910	1886	1871	1855	1827	1799	1780	1760	1747	1734	1700	1659	1617	-	-
	Med High	4	W			1799	1783	1767	1744	1720	1693	1666	1649	1631	1617	1603	1560	1530	1492	-	-
	Med	3	Y1			1694	1680	1666	1642	1617	1592	1567	1552	1537	1519	1500	1453	1421	1372	-	-
	Med Low	2				1575	1560	1540	1520	1502	1487	1471	1448	1424	1409	1393	1351	1308	1266	-	-
	Low	1	G			1454	1406	1358	1333	1308	1285	1261	1239	1217	1198	1179	1072	1002	988	-	-
060	High	5	W	11 x 10	1	2230	2212	2193	2173	2152	2139	2125	2109	2092	2076	2059	2026	1992	1951	1892	1806
	Med High	4	Y1			2081	2065	2048	2032	2015	1998	1980	1963	1946	1928	1910	1880	1849	1806	1767	1728
	Med	3				1951	1931	1910	1889	1868	1850	1831	1812	1793	1774	1755	1722	1688	1654	1612	1562
	Med Low	2				1812	1790	1767	1748	1728	1708	1688	1671	1654	1640	1626	1584	1547	1510	1472	1417
	Low	1	G			1668	1651	1633	1612	1591	1566	1540	1525	1510	1491	1472	1433	1400	1351	1299	1208
070	High	5	W	11 x 10	1	2472	2454	2435	2414	2393	2371	2349	2328	2306	2289	2271	2236	2189	2121	2033	1936
	Med High	4	Y1			2271	2248	2225	2205	2184	2166	2147	2129	2110	2094	2078	2039	2011	1977	1930	1846
	Med	3				2133	2115	2096	2072	2047	2030	2013	1996	1979	1965	1950	1909	1873	1837	1793	1748
	Med Low	2				2008	1985	1962	1939	1915	1898	1880	1862	1843	1828	1812	1774	1742	1703	1669	1635
	Low	1	G			1806	1784	1761	1742	1722	1696	1669	1656	1642	1625	1607	1564	1527	1490	1443	1404

Factory settings are in Bold
 Air flow values are with dry coil and standard 1 in. filter

11/20/12

About 5-Speed ECM Constant Torque Motors

The 5-speed ECM is a 'Constant Torque' ECM motor and delivers air flow similar to a PSC but operates as efficiently as a variable speed ECM motor. Because it is an ECM motor, the 5-speed ECM can ramp slowly up or down like the variable speed ECM motor. There are 5 possible speed taps available on the 5-speed ECM motor with #1 being the lowest airflow and #5 being the highest airflow. These speed selections are preset at the time of manufacture and are easily changed in the field if necessary.

If more than one tap are energized at the same time, built in logic gives precedence to the highest tap number and allows air flow to change with G, Y1, Y2 and W signals. Each of those 5 speeds has a specific 'Torque' value programmed into the motor for each speed selection. As static pressure increases, airflow decreases resulting in less torque on

the rotor. The motor responds only to changes in torque and adjusts its speed accordingly.

The 5-speed ECM motor is powered by line voltage but the motor speed is energized by 24VAC.

5-Speed ECM Benefits:

- High efficiency
- Soft start
- 5 speeds with up to 4 speeds on-line
- Built in logic allows air flow to change with G, Y1, Y2 and W signals
- Super efficient low airflow continuous blower setting (G)

Blower Performance Data cont.

5-Speed ECM - Dual Capacity

Model	Motor Speed	Motor Tap	T'stat Cnct.	Blower Size	Motor HP	Airflow (cfm) at External Static Pressure (in. wg)															
						0	0.05	0.10	0.15	0.20	0.25	0.30	0.35	0.40	0.45	0.50	0.60	0.70	0.80	0.90	1.00
026	High	5	W	9 x 7	1/2	1120	1109	1097	1082	1066	1055	1044	1028	1011	1001	991	932	839	-	-	-
	Med High	4	Y2			1020	1006	991	980	968	950	932	922	911	894	876	849	812	-	-	-
	Med	3				917	906	895	884	872	854	836	824	812	792	772	754	719	-	-	-
	Med Low	2	Y1			836	824	812	794	776	765	754	735	715	703	691	653	631	-	-	-
	Low	1	G			735	721	707	687	666	653	640	622	603	589	574	533	-	-	-	-
038	High	5	W	11 x 10	1/2	1530	1503	1476	1453	1429	1413	1397	1376	1355	1342	1329	1276	1231	1173	-	-
	Med High	4	Y2			1413	1388	1363	1342	1321	1303	1285	1263	1240	1226	1212	1173	1016	946	-	-
	Med	3	Y1			1355	1325	1294	1276	1258	1235	1212	1188	1164	1144	1123	982	909	883	-	-
	Med Low	2				1336	1299	1261	1242	1222	1202	1181	1157	1132	1111	1090	937	874	830	-	-
	Low	1	G			1243	1182	1121	1061	1000	964	928	856	784	744	703	647	592	-	-	-
049	High	5	W	11 x 10	1	1934	1910	1886	1871	1855	1827	1799	1780	1760	1747	1734	1700	1659	1617	-	-
	Med High	4				1799	1783	1767	1744	1720	1693	1666	1649	1631	1617	1603	1560	1530	1492	-	-
	Med	3	Y2			1694	1680	1666	1642	1617	1592	1567	1552	1537	1519	1500	1453	1421	1372	-	-
	Med Low	2	Y1			1575	1560	1540	1520	1502	1487	1471	1448	1424	1409	1393	1351	1308	1266	-	-
	Low	1	G			1454	1406	1358	1333	1308	1285	1261	1239	1217	1198	1179	1072	1002	988	-	-
064	High	5	W	11 x 10	1	2245	2360	2214	2315	2173	2290	2136	2275	2103	2250	2070	2032	1998	1957	1910	1825
	Med High	4	Y2			2092	2073	2054	2035	2015	1995	1975	1958	1940	1922	1904	1880	1843	1806	1767	1728
	Med	3				1951	1931	1910	1889	1868	1850	1831	1812	1793	1774	1755	1722	1688	1654	1612	1562
	Med Low	2	Y1			1812	1796	1780	1761	1741	1718	1695	1682	1668	1651	1633	1591	1555	1518	1480	1433
	Low	1	G			1682	1661	1640	1616	1591	1573	1555	1533	1510	1495	1480	1441	1400	1351	1316	1263
072	High	5	W	11 x 10	1	2472	2360	2435	2315	2393	2290	2349	2275	2306	2250	2271	2236	2189	2121	2033	1936
	Med High	4	Y2			2271	2248	2225	2205	2184	2166	2147	2129	2110	2094	2078	2039	2011	1977	1930	1846
	Med	3				2133	2115	2096	2072	2047	2030	2013	1996	1979	1965	1950	1909	1873	1837	1793	1748
	Med Low	2	Y1			2008	1985	1962	1939	1915	1898	1880	1862	1843	1828	1812	1774	1742	1703	1669	1635
	Low	1	G			1806	1784	1761	1742	1722	1696	1669	1656	1642	1625	1607	1564	1527	1490	1443	1404

Factory speed settings are in **Bold**

3/16/12

Air flow values are with dry coil and standard filter

For wet coil performance first calculate the face velocity of the air coil (Face Velocity [fpm] = Airflow [cfm] / Face Area [sq ft]).

Then for velocities of 200 fpm reduce the static capability by 0.03 in. wg, 300 fpm by 0.08 in. wg, 400 fpm by 0.12 in. wg., and 500 fpm by 0.16 in. wg.

Highest setting is for auxiliary heat (W) and lowest setting is for constant blower (G). The "Y1" and "Y2" settings must be between the "G" and "W" settings.

Setting Blower Speed - 5-Speed ECM

5-speed ECM blower motors have five (5) speeds of which three (3) are selectable on single speed and four (4) are selectable on dual capacity.



CAUTION: Disconnect all power before performing this operation.

5-Speed ECM Motor Connections - Single Speed

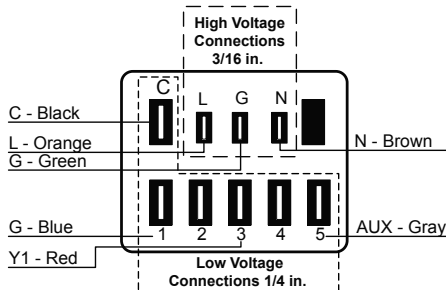

5-Speed ECM Motor Connections - Dual Capacity

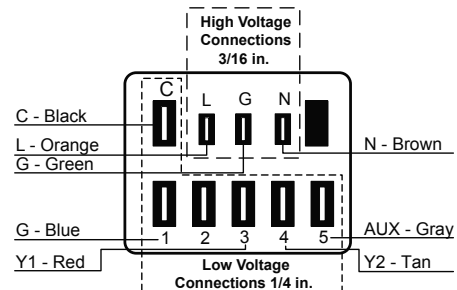

Blower Performance Data cont.

Variable Speed ECM Motor Single Speed

Model	Max ESP	Blower Size	Motor hp	Airflow DIP Switch Settings											
				1	2	3	4	5	6	7	8	9	10	11	12
015	0.50	9 x 7	1/2	300	400 L	500	600 M	700 H							
018	0.50	9 x 7	1/2	300	400 L	500	600 M	700 H	800						
024	0.50	9 x 7	1/2		400	500 L	600 M	700	800 H	900	1000	1100	1200		
030	0.50	9 x 7	1/2		400	500 L	600	700 M	800	900 H	1000	1100	1200		
036	0.50	11 x 10	1/2	650	750	850 L	1000	1100 M	1200	1300 H	1400	1500			
036 w/1hp*	0.75	11 x 10	1	800	1000 L	1100 M	1300 H	1500	1600	1800					
042	0.50	11 x 10	1/2	650	800	900 L	1050	1150 M	1250	1350	1450 H	1550			
042 w/1hp*	0.75	11 x 10	1	800	900 L	1000	1200 M	1400 H	1600	1700	1850	2000	2200	2300	2400
048	0.50	11 x 10	1/2	650	800	900	1050 L	1150	1250	1350 M	1450	1550 H			
048 w/1hp*	0.75	11 x 10	1	800	900	1000 L	1200	1400 M	1600 H	1700	1850	2000	2200	2300	2400
060	0.75	11 x 10	1	800	950	1100 L	1300	1500 M	1750	1950 H	2100	2300			
070	0.75	11 x 10	1	800	950	1100 L	1300	1500	1750 M	1950	2100 H	2300			

3/16/12

Dual Capacity

Model	Max ESP	Blower Size	Motor hp	Air Flow DIP Switch Settings											
				1	2	3	4	5	6	7	8	9	10	11	12
026	0.50	9 x 7	1/2		400	500 L	600	700 M	800	900 H	1000	1100	1200		
038	0.50	11 x 10	1/2	650	750 L	850	1000	1100 M	1200	1300 H	1400	1500			
038 w/1hp*	0.75	11 x 10	1	800 L	1000	1100 M	1300 H	1500	1600	1800					
049	0.50	11 x 10	1/2	650	800 L	900	1050	1150	1250	1350 M	1450	1550 H			
049 w/1hp*	0.75	11 x 10	1	800 L	900	1000	1200	1400 M	1600 H	1700	1850	2000	2200	2300	2400
064	0.75	11 x 10	1	800	950 L	1100	1300	1500 M	1750	1950 H	2100	2300			
072	0.75	11 x 10	1	800	950	1100 L	1300	1500	1750 M	1950	2100 H	2300			

Factory settings are at recommended L-M-H DIP switch locations

M-H settings MUST be located within boldface cfm range

Lowest and Highest DIP switch settings are assumed to be L and H respectively

cfm is controlled within ±5% up to the maximum ESP

Max ESP includes allowance for wet coil and 1 in. MERV 4

3/16/12

Blower Performance Data cont.

Setting Blower Speed - Variable Speed ECM

The ABC board's Yellow Config LED will flash the current variable speed ECM blower speed selections for low, med, and high continuously with a short pause in between. The speeds can also be confirmed with the AID Tool under the Setup/ECM Setup screen. The variable speed ECM blower motor speeds can be field adjusted with or without using an AID Tool.

Variable Speed ECM Setup without an AID Tool

The blower speeds for Low (G only), Med (Y1), and High (Y2/Aux) can be adjusted directly at the Aurora ABC board which utilizes the push button (SW1) on the ABC board. This procedure is outlined in the Variable Speed ECM Configuration Mode portion of the Aurora 'Base' Control System section.

Variable Speed ECM Setup with an AID Tool

A much easier method utilizes the AID Tool to change the airflow using the procedure below. First navigate to the Setup screen and then select ECM Setup. This screen displays the current variable speed ECM settings. It allows the technician to enter the setup screens to change the variable speed ECM settings. Change the highlighted item using the ◀ and ▶ buttons and then press the ◻ button to select the item.

Variable Speed ECM Setup with an AID Tool cont.

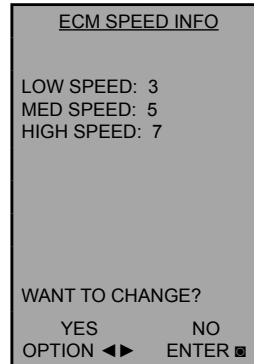

Selecting YES will enter variable speed ECM speed setup, while selecting NO will return to the previous screen.

Variable Speed ECM Speed Setup - These screens allow the technician to select the low, medium, and high blower speed for the variable speed ECM blower motor. Change the highlighted item using the ▲ and ▼ buttons. Press the ◻ button to select the speed.

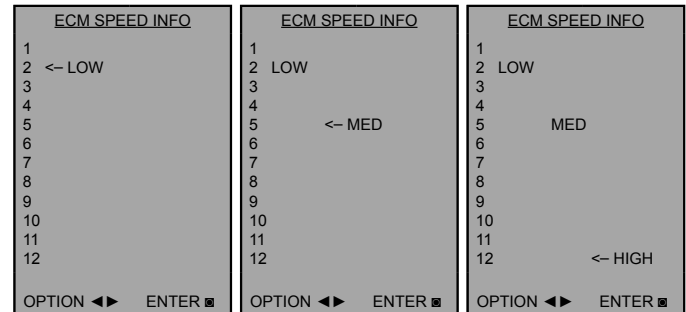

After the high speed setting is selected the AID Tool will automatically transfer back to the ECM Setup screen.

Wiring Schematics

Aurora Control 460/60/3 Variable Speed ECM

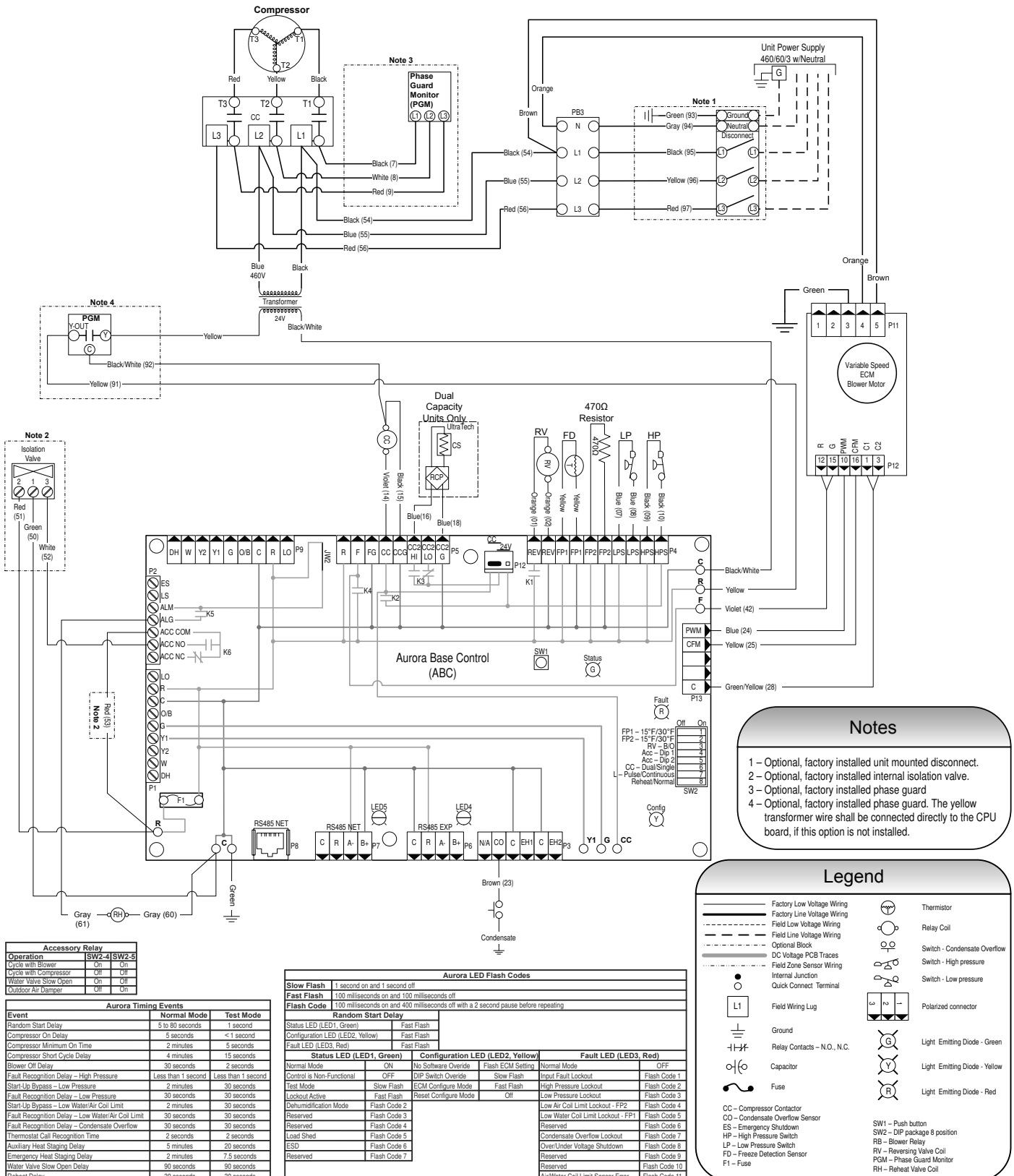

- ### Notes
- 1 - Optional, factory installed unit mounted disconnect.
 - 2 - Optional, factory installed internal isolation valve.
 - 3 - Optional, factory installed phase guard
 - 4 - Optional, factory installed phase guard. The yellow transformer wire shall be connected directly to the CPU board, if this option is not installed.

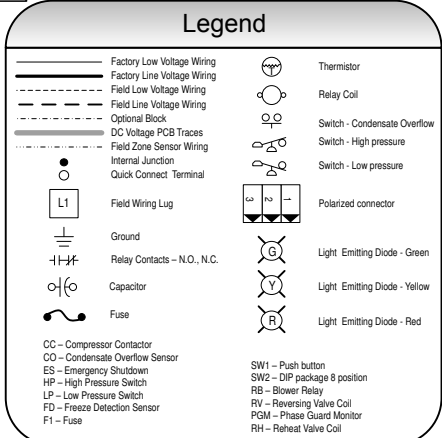

Accessory Relay		
Operation	SW2-4	SW2-3
Cycle with Blower	On	On
Cycle with Compressor	Off	Off
Water Valve Slow Open	On	Off
Outdoor Air Damper	Off	On

Aurora Timing Events		
Event	Normal Mode	Test Mode
Random Start Delay	5 to 80 seconds	1 second
Compressor On Delay	5 seconds	<1 second
Compressor Minimum On Time	2 minutes	5 seconds
Compressor Short Cycle Delay	4 minutes	15 seconds
Blower Off Delay	30 seconds	2 seconds
Fault Recognition Delay - High Pressure	Less than 1 second	Less than 1 second
Start-Up Bypass - Low Pressure	2 minutes	30 seconds
Fault Recognition Delay - Low Pressure	30 seconds	30 seconds
Start-Up Bypass - Low Water/Air Coil Limit	2 minutes	30 seconds
Fault Recognition Delay - Low Water/Air Coil Limit	30 seconds	30 seconds
Fault Recognition Delay - Condensate Overflow	30 seconds	30 seconds
Thermostat Call Recognition Time	2 seconds	2 seconds
Auxiliary Heat Staging Delay	5 minutes	20 seconds
Emergency Heat Staging Delay	2 minutes	30 seconds
Water Valve Slow Open Delay	90 seconds	90 seconds
Reheat Delay	30 seconds	30 seconds

Aurora LED Flash Codes			
Slow Flash	1 second on and 1 second off		
Fast Flash	100 milliseconds on and 400 milliseconds off		
Flash Code	100 milliseconds on and 400 milliseconds off with a 2 second pause before repeating		
Random Start Delay			
Status LED (LED1, Green)	Fast Flash		
Configuration LED (LED2, Yellow)	Fast Flash		
Fault LED (LED3, Red)	Fast Flash		
Status LED (LED1, Green)		Configuration LED (LED2, Yellow)	
Normal Mode	ON	No Software Override	Flash ECM Setting
Control is Non-Functional	OFF	DIP Switch Override	Slow Flash
Test Mode	Slow Flash	ECM Configure Mode	Fast Flash
Lockout Active	Fast Flash	Reset Configure Mode	Off
Dehumidification Mode	Flash Code 3		
Reserved	Flash Code 2		
Reserved	Flash Code 4		
Load Shed	Flash Code 5		
ESD	Flash Code 6		
Reserved	Flash Code 7		
Fault LED (LED3, Red)		Normal Mode	
Input Fault Lockout	Flash Code 1	High Pressure Lockout	Flash Code 2
High Pressure Lockout	Flash Code 2	Low Pressure Lockout	Flash Code 3
Low Pressure Lockout	Flash Code 3	Low Air Coil Limit Lockout - FP2	Flash Code 4
Low Air Coil Limit Lockout - FP2	Flash Code 4	Low Water Coil Limit Lockout - FP1	Flash Code 5
Low Water Coil Limit Lockout - FP1	Flash Code 5	Reserved	Flash Code 6
Reserved	Flash Code 6	Condensate Overflow Lockout	Flash Code 7
Condensate Overflow Lockout	Flash Code 7	Over/Under Voltage Shutdown	Flash Code 8
Over/Under Voltage Shutdown	Flash Code 8	Reserved	Flash Code 9
Reserved	Flash Code 9	Reserved	Flash Code 10
Reserved	Flash Code 10	Air/Water Coil Limit Sensor Error	Flash Code 11

Wiring Schematics cont.

Aurora Base Control 460/60/3 5-Speed ECM with Reheat

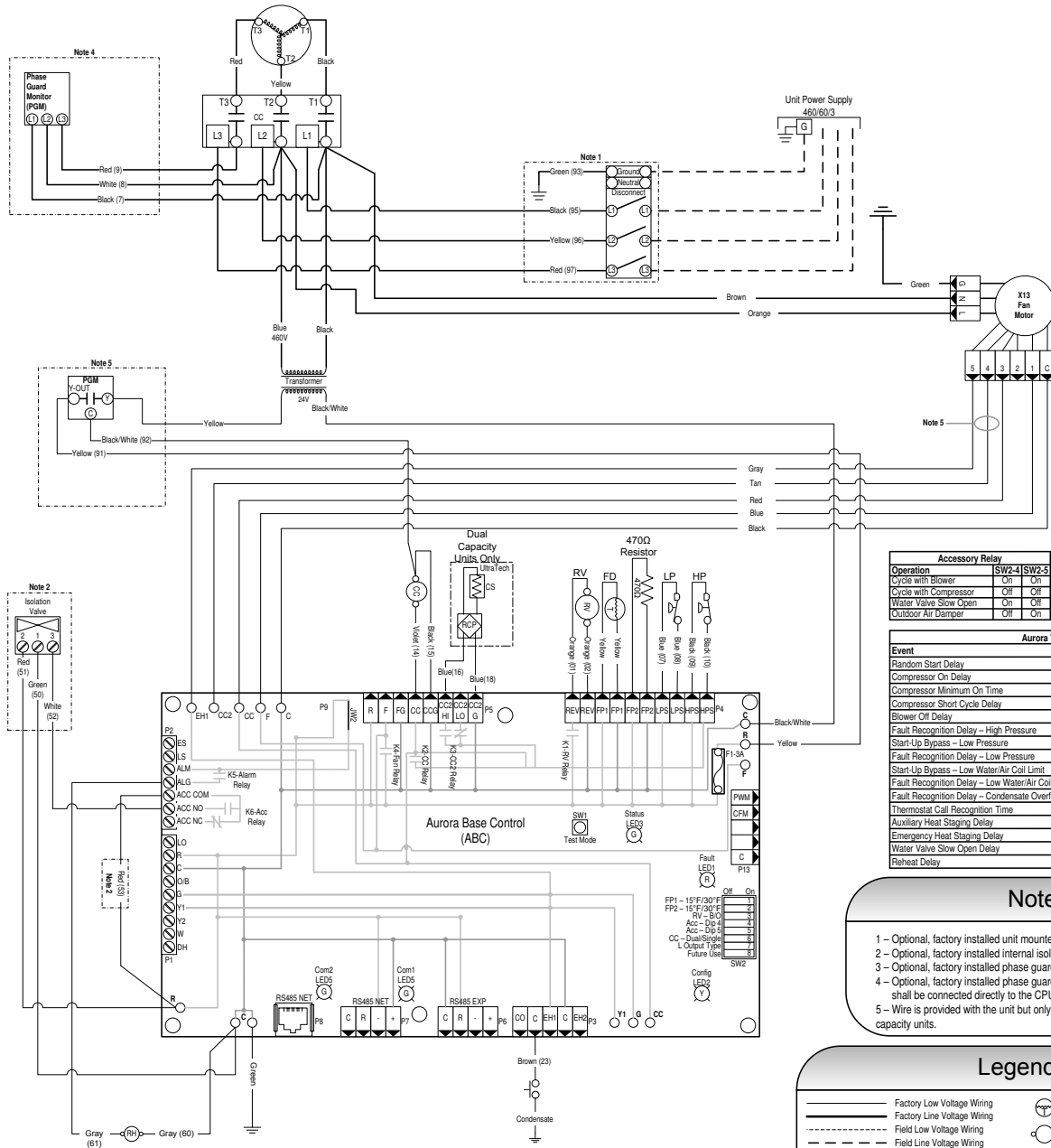

Accessory Relay		
Operation	SW2-4	SW2-5
Cycle with Blower	On	On
Cycle with Compressor	Off	Off
Water Valve Slow Open	On	Off
Outdoor Air Blower	Off	On

Aurora Timing Events		
Event	Normal Mode	Test Mode
Random Start Delay	5 to 80 seconds	1 second
Compressor On Delay	5 seconds	<1 second
Compressor Minimum On Time	2 minutes	5 seconds
Compressor Short Cycle Delay	4 minutes	15 seconds
Blower Off Delay	30 seconds	2 seconds
Fault Recognition Delay - High Pressure	Less than 1 second	Less than 1 second
Start-Up Bypass - Low Pressure	2 minutes	30 seconds
Fault Recognition Delay - Low Pressure	30 seconds	30 seconds
Start-Up Bypass - Low Water/Air Coil Limit	2 minutes	30 seconds
Fault Recognition Delay - Low Water/Air Coil Limit	30 seconds	30 seconds
Fault Recognition Delay - Condensate Overflow	30 seconds	30 seconds
Thermostat Call Recognition Time	2 seconds	2 seconds
Auxiliary Heat Staging Delay	5 minutes	20 seconds
Emergency Heat Staging Delay	2 minutes	7.5 seconds
Water Valve Slow Open Delay	30 seconds	30 seconds
Reheat Delay	30 seconds	30 seconds

- Notes:**
- 1 - Optional, factory installed unit mounted disconnect.
 - 2 - Optional, factory installed internal isolation valve.
 - 3 - Optional, factory installed phase guard.
 - 4 - Optional, factory installed phase guard. The yellow transformer wire shall be connected directly to the CPU board, if this option is not installed.
 - 5 - Wire is provided with the unit but only connected to the X13 motor on dual capacity units.

Legend

- Factory Low Voltage Wiring
- Factory Line Voltage Wiring
- Field Low Voltage Wiring
- Field Line Voltage Wiring
- Optional Block
- DC Voltage PCB Traces
- Field Zone Sensor Wiring
- Internal Junction
- Quick Connect Terminal
- Field Wiring Lug
- Ground
- Relay Contacts - N.O., N.C.
- Capacitor
- Fuse
- Thermistor
- Relay Coil
- Switch - Condensate Overflow
- Switch - High pressure
- Switch - Low pressure
- Polarized connector
- Light Emitting Diode - Green
- Light Emitting Diode - Yellow
- Light Emitting Diode - Red

CC - Compressor Contactor
 CO - Condensate Overflow Sensor
 ES - Emergency Shutdown
 DC - DC Voltage PCB Traces
 FZ - Field Zone Sensor
 HP - High Pressure Switch
 LP - Low Pressure Switch
 FD - Freeze Detection Sensor
 F1 - Fuse
 SW1 - Push button
 SW2 - DIP package 8 position
 RB - Blower Relay
 RV - Reversing Valve Coil
 PGM - Phase Guard Monitor
 RH - Reheat Valve Coil

Aurora LED Flash Codes					
Slow Flash	1 second on and 1 second off				
Fast Flash	100 milliseconds on and 100 milliseconds off				
Flash Code	100 milliseconds on and 400 milliseconds off with a 2 second pause before repeating				
Random Start Delay					
Status LED (LED1, Green)	Fast Flash				
Configuration LED (LED2, Yellow)	Fast Flash				
Fault LED (LED3, Red)	Fast Flash				
Status LED (LED1, Green)		Configuration LED (LED2, Yellow)		Fault LED (LED3, Red)	
Normal Mode	ON	No Software Override	Flash ECM Setting	Normal Mode	OFF
Control is Non-Functional	OFF	DIP Switch Override	Slow Flash	Input Fault Lockout	Flash Code 1
Test Mode	Flash	ECM Configure Mode	Fast Flash	High Pressure Lockout	Flash Code 2
Lockout Active	Fast Flash	Reset Configure Mode	Off	Low Pressure Lockout	Flash Code 3
Dehumidification Mode	Flash Code 2			Low Air Coil Limit Lockout - FP2	Flash Code 4
Reserved	Flash Code 3			Low Water Coil Limit Lockout - FP1	Flash Code 5
Reserved	Flash Code 4			Reserved	Flash Code 6
Load Shed	Flash Code 5			Condensate Overflow Lockout	Flash Code 7
ESD	Flash Code 6			Over/Under Voltage Shutdown	Flash Code 8
Reserved	Flash Code 7			Reserved	Flash Code 9
				Reserved	Flash Code 10
				Air/Water Coil Limit Sensor Error	Flash Code 11

Wiring Schematics cont.

FX10 Control 460/60/3 5-Speed ECM

- Notes:**
- 1 - Disconnect for 15 degree freeze detection limit.
 - 2 - Acc 1 output is cycled with the compressor.
 - 3 - Acc 2 output is cycled with the blower.
 - 4 - R, C, Y1, Y2, and G inputs are for use with a wall mount thermostat.
 - 5 - TO, SC, RS, AIC, and SS are for use with a TAXXJ02 zone sensor.
 - 6 - Network controllable 24VAC output.
 - 7 - Wire #52 can be used to connect a field supplied and installed 0-5 VDC humidity transmitter.
 - 8 - Not Used - Bundle in the air handler.
 - 9 - Optional, factory installed unit mounted disconnect
 - 10 - Optional, factory installed phase guard
 - 11 - Optional, factory installed phase guard. The yellow transformer wire shall be connected directly to the PB1-1, if this option is not installed.
 - 12 - Optional, factory installed internal isolation valve.
 - 14 - Network configurable input.
 - 15 - Refer to the 5-Spd ECM Low Voltage Connection Table.

5-Spd ECM Low Voltage Connections Single Speed

Model	TAP-1	TAP-2	TAP-3	TAP-4	TAP-5
015	Blue	Red		Gray	
018	Blue	Red		Gray	
024	Blue		Red	Gray	
030	Blue		Red	Gray	
036	Blue		Red	Gray	
042	Blue		Red	Gray	
048	Blue	Red		Gray	
060	Blue	Red		Gray	
070	Blue	Red		Gray	

Motor Low Voltage Connections Dual Capacity

Model	TAP-1	TAP-2	TAP-3	TAP-4	TAP-5
026	Blue	Red		Tan	Gray
038	Blue		Red	Tan	Gray
049	Blue	Red		Tan	Gray
064	Blue	Red		Tan	Gray
072	Blue	Red		Tan	Gray

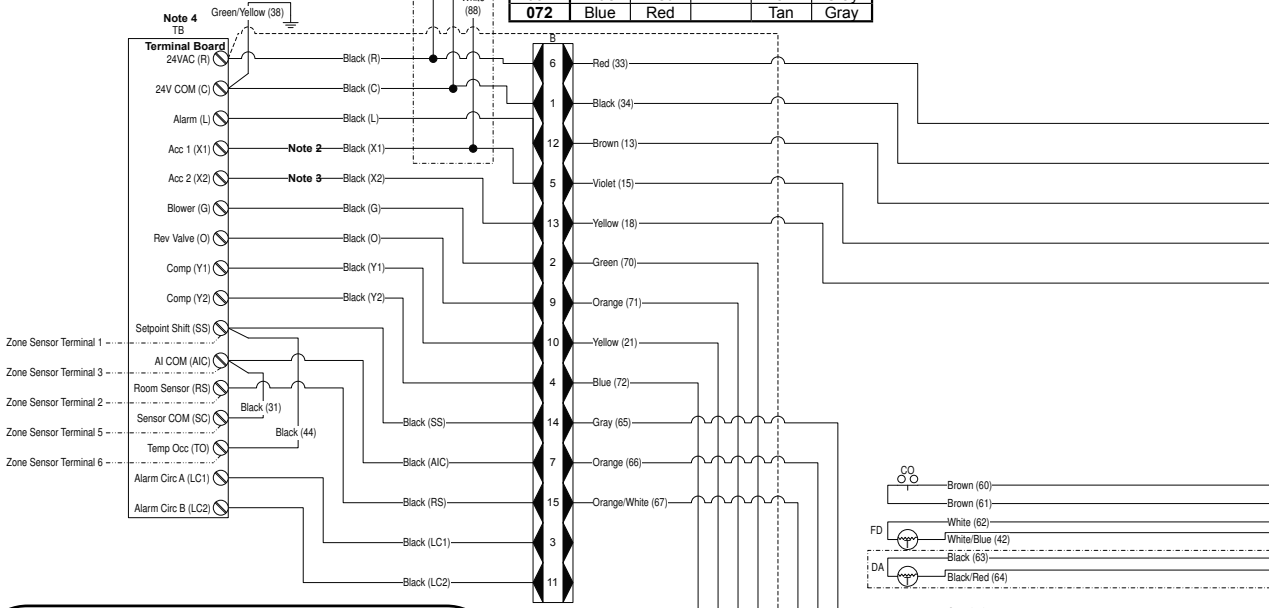
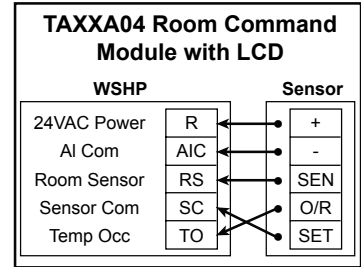

Legend

CC - Compressor Contactor
CO - Condensate Overflow Sensor
CP - Compressor Proving
CS - Compressor Solenoid
DA - Discharge Air Temperature Sensor
DF/BP - Dirty Filter or Blower Proving
DH - Dehumidification Switch or Humidistat
ES - Emergency Shutdown
HP - High Pressure Switch
LP - Low Pressure Switch
OS - Occupied Switch
PB1, PB2 - Power blocks
PH - Pump Relay
RB - Reversing Valve coil
RCP - Rectified Solenoid Compressor Plug
RV - Reversing Valve coil
TB - Terminal Board
FD - Freeze Detection Sensor
PGM - Phase Guard Module
RH - Reheat Valve Coil

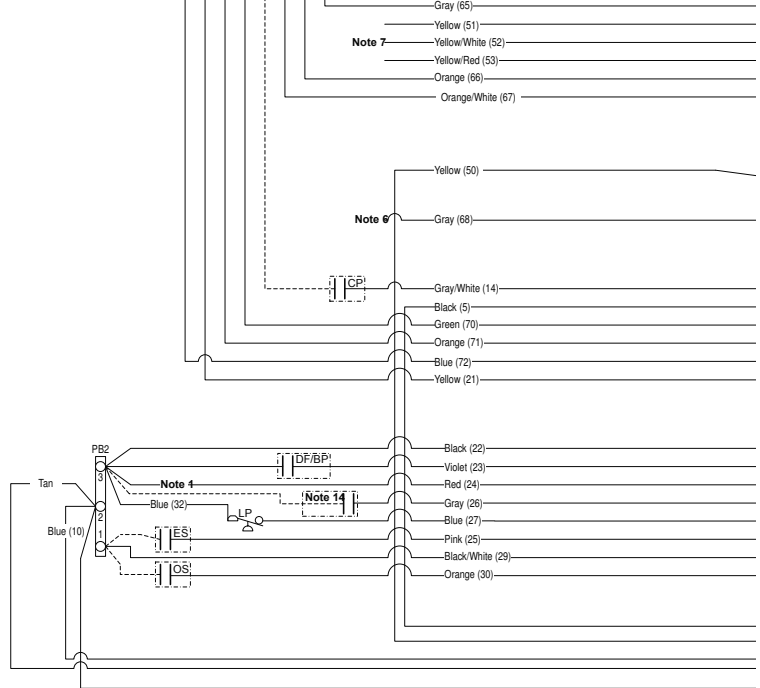

Wiring Schematics cont.

FX10 Control 460/60/3 5-Speed ECM cont.

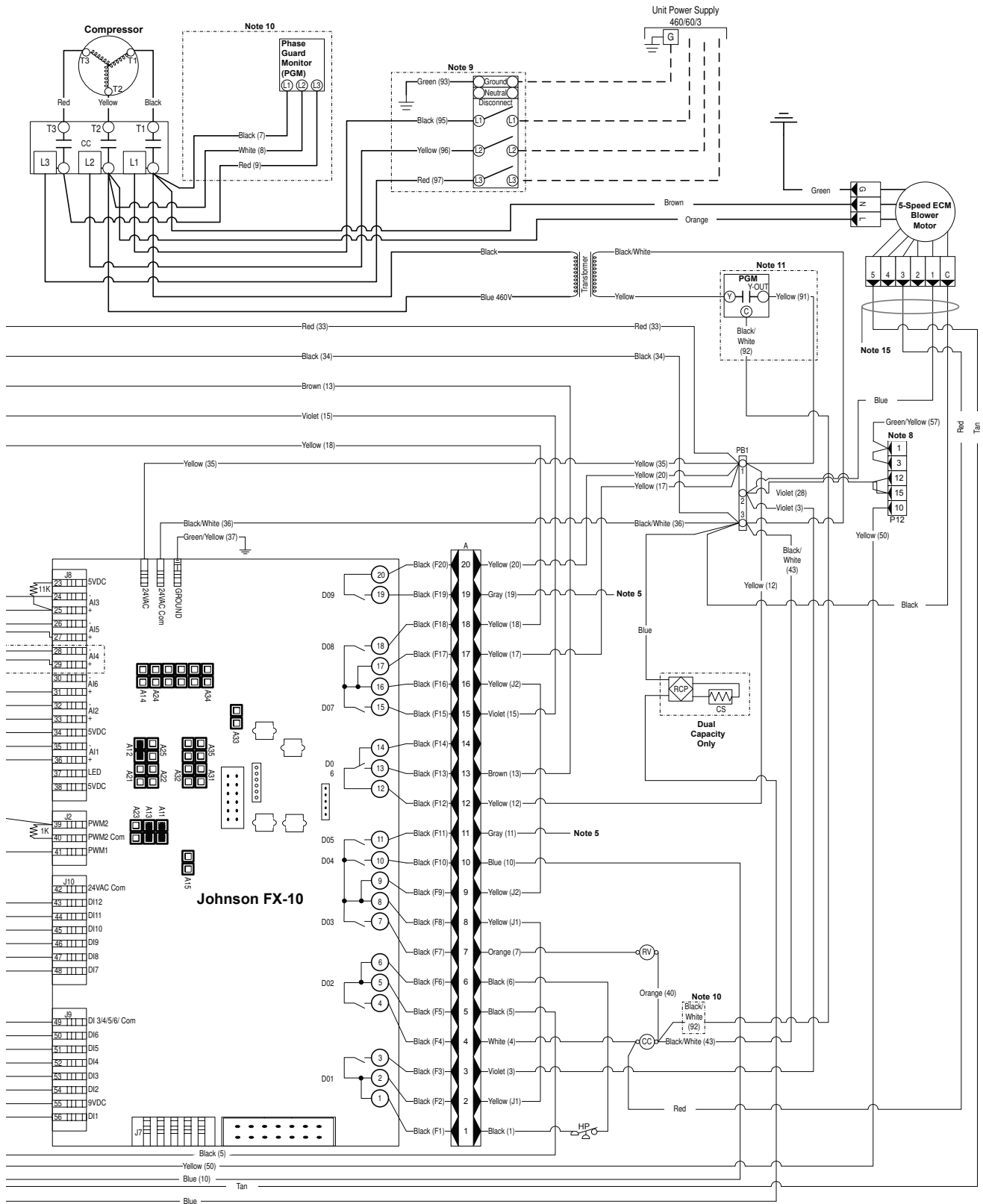

Wiring Schematics cont.

Hot Gas Reheat

Humidity Sensor Terminal Block

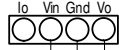

Connect to C on the Low Volt Terminal Board
 Connect to R on the Low Volt Terminal Board

NOTE: Reversing these two wires will cause the transformer breaker to trip

(NOT USED) — Yellow (51)
 — Yellow Wht (52)

Dehumidistat Wiring

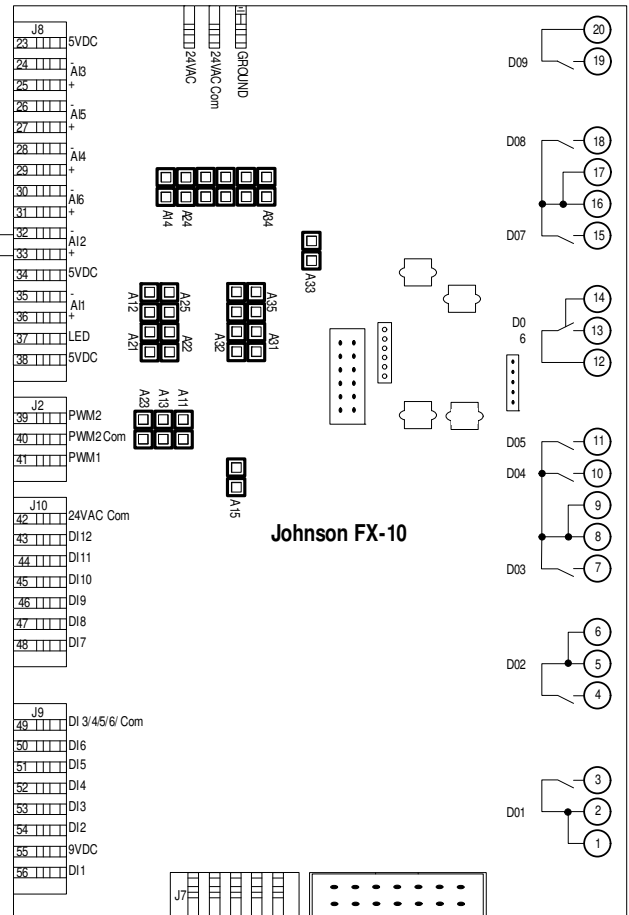
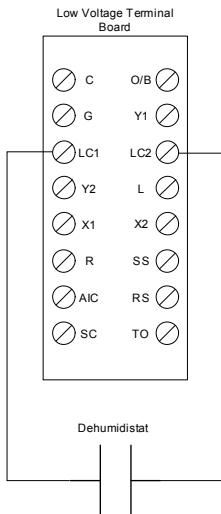

Controls - Aurora Base Control

Aurora 'Base' Control

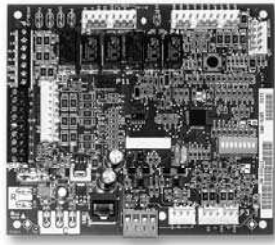

NOTE: Refer to the Aurora Base Control Application and Troubleshooting Guide and the Instruction Guide: Aurora Interface and Diagnostics (AID) Tool for additional information.

Control Features

Software ABC Standard Version 2.0

Single or Dual Capacity Compressors

Either single or dual capacity compressors can be operated.

ECM Blower Motor Option

An ECM blower motor can be driven directly using the onboard PWM output. Four blower speeds are available based upon the G, Y1, Y2, and W input signals to the board. The blower speeds can be changed either by the ECM manual configurations mode method or by using the Aurora AID Tool directly. All four blower speeds can be set to the same speed if desired.

5-Speed ECM Blower Motor Option

A 5-Speed ECM blower motor will be driven directly using the thermostat connections. Any of the G, Y1, or Y2/W signals can drive any of the 5 available pre-programmed blower speeds on the motor.

Other Control Features

- Random start at power up
- Anti-short cycle protection
- High and low pressure cutouts
- Loss of charge
- Water coil freeze detection
- Air coil freeze detection
- Over/under voltage protection
- Condensate overflow sensor
- Load shed
- Dehumidification (where applicable)
- Emergency shutdown
- Hot gas reheat operation (where applicable)
- Diagnostic LED
- Test mode push button switch
- Two auxiliary electric heat outputs
- Alarm output
- Accessory output with N.O. and N.C.
- Modbus communication (master)
- Modbus communication (slave)

Field Selectable Options via Hardware

DIP Switch (SW1) – Test/Configuration Button (See SW1 Operation Table)

Test Mode

The control is placed in the test mode by holding the push button switch SW1 for 2 - 5 seconds. In test mode most of the control timings will be shortened by a factor of sixteen (16). LED3 (green) will flash at 1 second on and 1 second off. Additionally, when entering test mode LED1 (red) will flash the last lockout one time. Test mode will automatically time out after 30 minutes. Test mode can be exited by pressing and holding the SW1 button for 2 to 5 seconds or by cycling the power. **NOTE:** Test mode will automatically be exited after 30 minutes.

ECM Configuration Mode

The control is placed in the ECM configuration mode by holding the pushbutton switch SW1 for 5 to 10 seconds, the high, low, and "G" ECM speeds can be selected by following the LED display lights. LED2 (yellow) will fast flash when entering the ECM configuration. When setting "G" speed LED3 (green) will be continuously lit, for low speed LED1 (red) will be continuously lit, and for high speed both LED3 (green) and LED1 (red) will be continuously lit. During the ECM configuration mode LED2 (yellow) will flash each of the 12 possible blower speeds 3 times. When the desired speed is flashed press SW1, LED2 will fast flash until SW1 is released. "G" speed has now been selected. Next select low speed, and high speed blower selections following the same process above. After third selection has been made, the control will exit the ECM configuration mode. Aux fan speed will remain at default or current setting and requires the AID Tool for adjustment.

Reset Configuration Mode

The control is placed in reset configuration mode by holding the push button switch SW1 for 50 to 60 seconds. This will reset all configuration settings and the EEPROM back to the factory default settings. LED3 (green) will turn off when entering reset configuration mode. Once LED3 (green) turns off, release SW1 and the control will reset.

DIP Switch (SW2)

- SW2-1** FP1 Selection – Low water coil temperature limit setting for freeze detection. On = 30°F; Off = 15°F.
- SW2-2** FP2 Selection – On = 30°F; Off = N/A
- SW2-3** RV – O/B - thermostat type. Heat pump thermostats with "O" output in cooling or "B" output in Heating can be selected. On = O; Off = B.
- SW2-4** Access Relay Operation (P2)

Access Relay Operation	SW2-4	SW2-5
Cycle with Blower	ON	ON
Cycle with Compressor	OFF	OFF
Water Valve Slow Opening	ON	OFF
Cycle with Comm. T-stat Hum Cmd	OFF	ON

Controls - Aurora Base Control cont.

Cycle with Blower - The accessory relay will cycle with the blower output.

Cycle with Compressor - The accessory relay will cycle with the compressor output.

Water Valve Slow Opening - The accessory relay will cycle and delay both the blower and compressor output for 90 seconds.

- SW2-6** CC Operation – selection of single or dual capacity compressor. On = Single Stage; Off = Dual Capacity
- SW2-7** Lockout and Alarm Outputs (P2) – selection of a continuous or pulsed output for both the LO and ALM Outputs. On = Continuous; Off = Pulsed
- SW2-8** Future Use

Alarm Jumper Clip Selection

From the factory, ALM is connected to 24 VAC via JW2. By cutting JW2, ALM becomes a dry contact connected to ALG.

ECM Blower Speeds

The blower speeds can be changed either by using the ECM manual configurations mode method or by using the Aurora AID Tool directly (see Instruction Guide: Aurora Interface and Diagnostics (AID) Tool topic).

Field Selectable Options via Software

(Selectable via the Aurora AID Tool)

ECM Blower Speeds

An ECM blower motor can be driven directly using the onboard PWM output. Four blower speeds are available, based upon the “G”, Y1 (low), Y2 (high), and Aux input signals to the board. The blower speeds can be changed either by the ECM manual configurations mode method (see ECM Configuration Mode topic) or by using the Aurora AID Tool directly. All four blower speeds can be set to the same speed if desired. Aux blower speed will remain at default or current setting and requires the AID Tool for adjustment.

Safety Features

The following safety features are provided to protect the compressor, heat exchangers, wiring and other components from damage caused by operation outside of design conditions.

Fuse – a 3 amp automotive type plug-in fuse provides protection against short circuit or overload conditions.

Anti-Short Cycle Protection – 4 minute anti-short cycle protection for the compressor.

Random Start – 5 to 80 second random start upon power up.

Fault Retry – in the fault condition, the control will stage off the outputs and then “try again” to satisfy the thermostat Y input call. Once the thermostat input calls are satisfied, the control will continue on as if no fault occurred. If 3 consecutive faults occur without satisfying the thermostat Y input call, then the control will go to Lockout mode.

Lockout – when locked out, the blower will operate continuously in “G” speed, and PSC blower motor output will remain on. The Alarm output (ALM) and Lockout output (L) will be turned on. The fault type identification display LED1 (Red) shall flash the fault code. To reset lockout conditions with SW2-8 On, thermostat inputs “Y1”, “Y2”, and “W” must be removed for at least 3 seconds. To reset lockout conditions with SW2-8 Off, thermostat inputs “Y1”, “Y2”, “W”, and “DH” must be removed for at least 3 seconds. Lockout may also be reset by turning power off for at least 30 seconds or by enabling the emergency shutdown input for at least 3 seconds.

Lockout With Emergency Heat - if the control is locked out in the heating mode, and a Y2 or W input is received, the control will operate in the emergency heat mode while the compressor is locked out. The first emergency heat output will be energized 10 seconds after the W input is received, and the blower will shift to high speed. If the control remains locked out, and the W input is present, additional stage of emergency heat will stage on after 2 minutes. When the W input is removed, all of the emergency heat outputs will turn off, and the ECM blower will shift to “G” speed and PSC blower motor output will remain on.

High Pressure – fault is recognized when the Normally Closed High Pressure Switch, P4-9/10 opens, no matter how momentarily. The High Pressure Switch is electrically in series with the Compressor Contactor and serves as a hard-wired limit switch if an overpressure condition should occur.

Low Pressure - fault is recognized when the Normally Closed Low Pressure Switch, P4-7/8 is continuously open for 30 seconds. Closure of the LPS any time during the 30 second recognition time restarts the 30 second continuous open requirement. A continuously open LPS shall not be recognized during the 2 minute startup bypass time.

Loss of Charge – fault is recognized when the Normally Closed Low Pressure Switch, P4-7/8 is open prior to the compressor starting.

Condensate Overflow - fault is recognized when the impedance between this line and 24 VAC common or chassis ground drops below 100K ohms for 30 seconds continuously.

Freeze Detection (Coax) - set points shall be either 30°F or 15°F. When the thermistor temperature drops below the selected set point, the control shall begin counting down the 30 seconds delay. If the thermistor value rises above the selected set point, then the count should reset. The resistance value must remain below the selected set point for the entire length of the appropriate delay to be recognized as a fault. This fault will be ignored for the initial 2 minutes of the compressor run time.

Freeze Detection (Air Coil) - uses the FP2 input to protect against ice formation on the air coil. The FP2 input will operate exactly like FP1 except that the set point is 30 degrees and is not field adjustable.

Controls - Aurora Base Control cont.

Over/Under Voltage Shutdown - An over/under voltage condition exists when the control voltage is outside the range of 18 VAC to 30 VAC. If the over/under voltage shutdown lasts for 15 minutes, the lockout and alarm relay will be energized. Over/under voltage shutdown is self-resetting in that if the voltage comes back within range of 18 VAC to 30 VAC for at least 0.5 seconds, then normal operation is restored.

Operation Description

Power Up - The unit will not operate until all the inputs and safety controls are checked for normal conditions. The unit has a 5 to 80 second random start delay at power up. Then the compressor has a 4 minute anti-short cycle delay after the random start delay.

Standby In standby mode, Y1, Y2, W, DH, and G are not active. Input O may be active. The blower and compressor will be off.

Heating Operation

Heating, 1st Stage (Y1) - The blower is started on "G" speed immediately and the compressor is energized 10 seconds after the Y1 input is received. The ECM blower motor is switched to low speed 15 seconds after the Y1 input.

Heating, 2nd Stage (Y1, Y2) - The compressor will be staged to full capacity 20 seconds after Y2 input is received. The ECM blower will shift to high speed 15 seconds after the Y2 input is received.

Heating, 3rd Stage (Y1, Y2, W) - The hot water pump is de-energized and the first stage of electric heat is energized 10 seconds after the W command is received. If the demand continues the second stage of electric heat will be energized after 5 minutes.

Emergency Heat (W) - The blower will be started on "G" speed, 10 seconds later the first stage of electric heat will be turned on. 5 seconds after the first stage of electric heat is energized the blower will shift to Aux speed. If the emergency heat demand is not satisfied after 2 minutes the second electric heat stage will be energized.

Blower (G) - The blower will start immediately upon receiving a thermostat G command. If there are no other commands from the thermostat the ECM will run on "G" speed until the G command is removed. Regardless of blower input (G) from the thermostat, the blower will remain on for 30 seconds at the end of each heating cycle.

Cooling Operation

In all cooling operations, the reversing valve directly tracks the O input. Thus, anytime the O input is present, the reversing valve will be energized.

Cooling, 1st Stage (Y1, O) - The blower is started on "G" speed immediately and the compressor is energized 10 seconds after the Y1 input is received. The ECM blower motor is switched to low speed 15 seconds after the Y1 input.

Cooling, 2nd Stage (Y1, Y2, O) - The compressor will be staged to full capacity 20 seconds after Y2 input is received. The ECM blower will shift to high speed 15 seconds after the Y2 input is received.

Blower (G) - The blower will start immediately upon receiving a thermostat G command. If there are no other commands from the thermostat the ECM will run on "G" speed until the G command is removed. Regardless of blower input (G) from the thermostat, the blower will remain on for 30 seconds at the end of each heating, cooling, and emergency heat cycle.

Dehumidification (Y1, O, DH or Y1, Y2, O, DH) - When a DH command is received from the thermostat during a compressor call for cooling the ECM blower speed will be reduced by 15% to increase dehumidification.

Emergency Shutdown - Four (4) seconds after a valid ES input, P2-7 is present, all control outputs will be turned off and remain off until the emergency shutdown input is no longer present. The first time that the compressor is started after the control exits the emergency shutdown mode, there will be an anti-short cycle delay followed by a random start delay. Input must be tied to common to activate.

Continuous Blower Operation - The blower output will be energized any time the control has a G input present, unless the control has an emergency shutdown input present. The blower output will be turned off when G input is removed.

Load Shed - The LS input disables all outputs with the exception of the blower output. When the LS input has been cleared, the anti-short cycle timer and random start timer will be initiated. Input must be tied to common to activate.

Controls - Aurora Base Control cont.

Aurora 'Base' Control LED Displays

These three LEDs display the status, configuration, and fault codes for the control. These can also be read in plain English via the Aurora AID Tool.

Status LED (LED3, Green)

Description of Operation	Fault LED, Green
Normal Mode	ON
Control is Non-functional	OFF
Test Mode	Slow Flash
Lockout Active	Fast Flash
Dehumidification Mode	Flash Code 2
(Future Use)	Flash Code 3
(Future Use)	Flash Code 4
Load Shed	Flash Code 5
ESD	Flash Code 6
(Future Use)	Flash Code 7

Configuration LED (LED2, Yellow)

Description of Operation	Configuration LED, Yellow
No Software Overwritten	Flashing ECM Setting
DIP Switch was Overwritten	Slow Flash
ECM Configuration Mode	Fast Flash

Fault LED (LED1, Red)

Red Fault LED		LED Flash Code*	Lockout	Reset/Remove
ABC Basic Faults	Normal - No Faults	OFF	-	
	Fault - Input	1	No	Auto
	Fault - High Pressure	2	Yes	Hard or Soft
	Fault - Low Pressure	3	Yes	Hard or Soft
	Fault - Freeze Detection FP2	4	Yes	Hard or Soft
	Fault - Freeze Detection FP1	5	Yes	Hard or Soft
	Fault - Condensate Overflow	7	Yes	Hard or Soft
	Fault - Over/Under Voltage	8	No	Auto
	Fault - FP1 & FP2 Sensor Error	11	Yes	Hard or Soft

NOTE: All codes >11 use long flash for tens digit and short flash for the ones digit. 20, 30, 40, 50, etc. are skipped.

Aurora Interface and Diagnostics (AID) Tool

The Aurora Interface and Diagnostics (AID) Tool is a device that is a member of the Aurora network. The AID Tool is used to troubleshoot equipment which uses the Aurora control via Modbus RTU communication. The AID Tool provides diagnostics, fault management, ECM setup, and system configuration capabilities to the Aurora family of controls. An AID Tool is recommended, although not required, for ECM airflow settings. The AID Tool simply plugs into the exterior of the cabinet in the AID Tool port.



ABC Control Board Layout

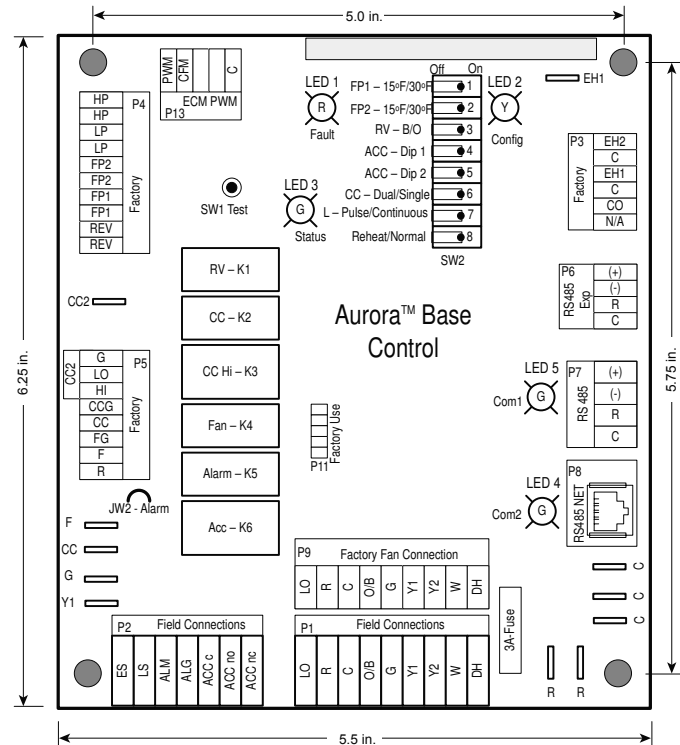

Controls - FX10 (optional)

Optional FX10 Microprocessor and BAS Interface

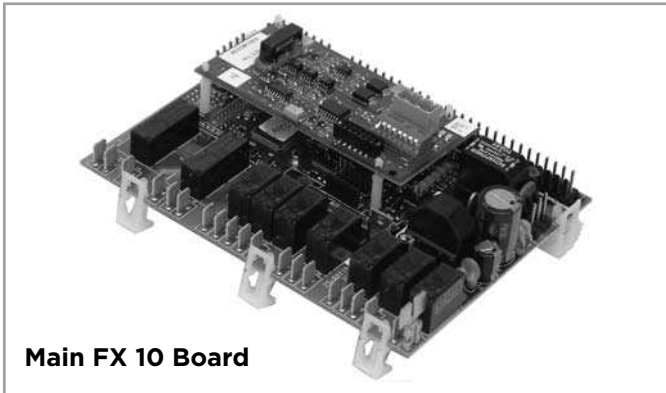

Main FX 10 Board

The FX10 is a microprocessor based control that not only monitors and controls the heat pump but also can communicate any of this information back to the building automation system (BAS). This means that not only does the control monitor the heat pump at the unit you can also monitor and control many the features over the BAS. This clearly puts the FX10 in a class of its own.

The control will enumerate all fault conditions (HP, LP, CO, LOC, and Freeze Detection) over a BAS as well as display them on a medium user interface (MUI). HP, LP, CO and Freeze Detection faults can all be reset over a BAS. A Loss Of Charge fault can not be reset or bypassed until the problem has been corrected. A MUI is invaluable as a service tool for the building service team.

The unit can be commanded to run by a typical heat pump thermostat or run based on heating and cooling set points supplied by a BAS. The control board is wired with quick connect harnesses for easy field change out of a bad control board. All variable speed ECM blower speed settings can be changed over a BAS or with a MUI. The control has an input programmed to enable field installed emergency heat in the event that the compressor is locked out. This input can also be commanded on from a BAS as needed. An alarm history can be viewed through the MUI and will be held in memory until the unit is power cycled. Relative humidity can be read by a 0-5VDC humidity sensor that is displayed over the network. If you are using a variable speed ECM blower motor the control can enable dehumidification mode based on a set point in the control. The dehumidification set point itself can also be changed over a BAS or with a MUI. Dehumidification mode can also be enabled by the BAS. Because the FX10 is not factory configured to read CO² levels, contact the factory for application assistance.

The FX10 control has unused analog and digital inputs for field installed items such as air temperature, water temperature, CO² or current status switches. The control has unused binary and PWM outputs that can be commanded over the BAS for field use.

An optional Medium User Interface (MUI) for control setup and advanced diagnostics is available with some mounting kits, MUIK3 - Panel mount version and the MUIK4-Wall mount version.

Zone Sensors

There are two options for zone sensors that can be used with the FX10 control. Both sensors use a Johnson controls A99 positive temperature coefficient type sensor. The TXXXJ02 has a set point adjustment now which will give the end user a +/- 5°F adjustment from the set point as well as a push button that can be used for temporary occupancy. The control leaves the factory set to operate with a TXXXJ02 sensor, the TXXXA04 sensor through a building automation system, or with a user interface.

Standard Features

- Anti Short Cycle
- High Pressure Protection
- Low Pressure Protection
- Freeze Detection
- Loss Of Charge Detection
- Random Start
- Display for diagnostics
- Reset Lockout at disconnect or through BAS
- 2 Accessory outputs
- Optional BAS add-on controls

DDC Operation and Connection

Other optional network protocol boards that can be added to the FX10 are:

- Johnson Control N2
- LonWorks
- BACnet
 - MS/TP @ 19,200 Baud rate
 - Limit devices to 30 on a single trunk line

Control and Safety Feature Details Emergency Shutdown

The emergency shutdown mode can be activated by a command from a facility management system or a closed contact on BI-2. The default state for the emergency shutdown data point is off. When the emergency shutdown mode is activated, all outputs will be turned off immediately and will remain off until the emergency shutdown mode is de-activated. The first time the compressor starts after the emergency shutdown mode has been de-activated, there will be a random start delay present.

Controls - FX10 (optional) cont.

Lockout Mode

Lockout mode can be activated by any of the following fault signals: refrigerant system high pressure, refrigerant system low pressure, freeze detection, and condensate overflow. When any valid fault signal remains continuously active for the length of its recognition delay, the controller will go into fault retry mode, which will turn off the compressor. After the Compressor short cycle delay, the compressor will attempt to operate once again. If three consecutive faults occur in 60 minutes during a single heating or cooling demand, the unit will go into lockout mode, turning off the compressor, enabling the alarm output, and setting the blower back to low speed operation until the controller is reset. If the control faults due to the low pressure input (BI-3) being open during the pre-compressor startup check, the control will go into lockout mode immediately, disabling the compressor from starting and enabling the alarm output (BO-6). The lockout condition can be reset by powering down the controller, by a command from the BAS, or by the holding the ESC and Return keys on the MUI for 5 seconds.

Freeze Detection (AI-5)



The freeze detection sensor will monitor the liquid refrigerant temperature entering the water coil in the heating mode. If the temperature drops below the freeze detection trip point for the recognition delay period, the condition will be recognized as a fault. The freeze detection trip point will be factory set for 30°F (-1°C) and will be field selectable for 15°F (-9°C) by removing a jumper wire on BI-5. The freeze detection fault condition will be bypassed 2 minutes at normal compressor startup, to allow the refrigeration circuit to stabilize. If the freeze detection sensor becomes unreliable at any time compressor operation will immediately be suspended until the problem is corrected. This should be displayed as an alarm on the BAS and the MUI. This alarm will be reported as a "Water Low Temp Limit" fault.

High Pressure (BI-11)

The high-pressure switch shall be a normally closed (NC) switch that monitors the systems refrigerant pressure. If the input senses the high-pressure switch is open it must disable the compressor output immediately and count the fault. The compressor minimum on time does not apply if the high-pressure switch opens. The compressor will not restart until the compressor short cycle time delay has been satisfied.

Low Pressure (BI-3)

The low-pressure switch shall be a normally closed (NC) switch that monitors the systems refrigerant pressure. The input shall be checked 15 seconds before compressor start up to be sure the pressure switch is closed and then ignored for the first 2 minutes after the compressor output (BO-2) is enabled. If the switch is open continuously for (30) seconds during compressor operation the compressor output (BO-2) will be disabled. The compressor will not restart until the compressor short cycle time delay has been satisfied.

Condensate Overflow

The condensate overflow sensing circuit will monitor the condensate level as a resistance input to AI-3. If the condensate water level rises resulting in the input resistance rising above the set point for the recognition delay period, the condition will be recognized as a fault. The condensate will be subjected to a (30) second lockout delay which requires that the fault be sensed for a continuous (30) seconds before suspending unit operation.

Alarm Output (BO-6)

The alarm output will be enabled when the control is in the lockout mode and will be disabled when the lockout is reset.

Test Mode

Raising the zone temperature input (AI-1) reading to 180–220°F or by holding the ESC and down arrow keys on the MUI for 5 seconds will put the control into test mode. In test mode the random start delay and the compressor fixed on delay time will both be shortened to 5 seconds and the reversing valve will be allowed to cycle with out shutting down the compressor. If an MUI is connected to the control LED 8 will flash and the words "Test Mode Enabled" will be shown on the LCD display when the control is in test mode. Test mode will be disabled after a power cycle, 30 minute timeout, or by holding the ESC and Up arrow keys on the MUI.

Sequence of Operation

Power Fail Restart

When the controller is first powered up, the outputs will be disabled for a random start delay. The delay is provided to prevent simultaneous starting of multiple heat pumps. Once the timer expires, the controller will operate normally.

Random Start Delay

This delay will be used after every power failure, as well as the first time the compressor is started after the control exits the unoccupied mode or the emergency shutdown mode. The delay should not be less than 1 second and not longer than 120 seconds. If the control is in test mode the random start delay will be shortened to 5 seconds.

Controls - FX10 (optional) cont.

Compressor Fixed On Delay Time

The Compressor Fixed On Delay Time will ensure that the compressor output (BO2) is not enabled for 90 seconds after the control receives a call to start the compressor. This delay is adjustable from 30 – 300 seconds over a BAS or a MUI. If the control is in test mode the Compressor Fixed On Delay Timer will be shortened to 5 seconds.

Compressor Minimum On Delay

The compressor minimum on delay will ensure that the compressor output is enabled for a minimum of two (2) minute each time the compressor output is enabled. This will apply in every instance except in the event the high pressure switch is tripped or emergency shutdown then the compressor output will be disable immediately.

Compressor Short Cycle Delay Time

The compressor short cycle time delay will ensure that the compressor output will not be enabled for a minimum of five (5) minutes after it is disabled. This allows for the system refrigerant pressures to equalize after the compressor is disabled.

Heating Cycle

On a call for heating, the blower enable output and accessory output 2 will turn on immediately after the random start delay timer has been satisfied. If the compressor short cycle time delay has been satisfied, the compressor will turn on after the blower enable and accessory output 2 are on and the fixed compressor start delay timers have been satisfied. **NOTE:** Auxiliary heat output can be controlled over the BAS.

Set Point Control Mode

In set point control mode the reversing valve output will be disabled. As the temperature drops below the heating set point and begins to operate in the heating proportional band, the compressor (low capacity for two-stage compressors) output (BO-2) will be enabled. For units with two-stage compressors, a PI loop in the programming of the control will determine when the full capacity compressor output (BO-4) is to be enabled. The compressor must be operating in low capacity for a minimum of 30 seconds before the full capacity compressor output can be enabled. During low capacity compressor operation the variable speed ECM blower will operate in medium speed and will operate in high speed when the compressor is operating at full capacity.

Thermostat Control Mode

In thermostat mode the compressor will be cycled based on Y1 and Y2 calls from a room thermostat. When the control receives a Y1 command (BI-7) from the thermostat the low capacity compressor output (BO2) will be enabled and the variable speed ECM blower will operate in medium speed. When the control receives a Y2 command (BI-8) from the thermostat the variable speed ECM blower will operate in high speed. During the heating cycle the reversing valve will be commanded into the off position.

Cooling Cycle

On a call for cooling, the blower enable output and accessory output 2 will turn on immediately after the random start delay timer has been satisfied. If the compressor short cycle time delay has been satisfied, the compressor will turn on after the blower enable and accessory output 2 are on and the fixed compressor start delay timers have been satisfied.

Set Point Control Mode

In set point control mode the reversing valve output will be enabled. As the temperature rises above the cooling set point and begins to operate in the cooling proportional band, the low capacity compressor output (BO-2) will be enabled. A PI loop in the programming of the control will determine when the full capacity compressor output (BO-4) is to be enabled. The compressor must be operating in low capacity for a minimum of 30 seconds before the full capacity compressor output can be enabled. During low capacity compressor operation the variable speed ECM blower will operate in medium speed and will operate in high speed when the compressor is operating at full capacity.

Thermostat Control Mode

In thermostat mode the compressor will be cycled based on Y1 and Y2 calls from a room thermostat. When the control receives a Y1 command (BI-7) from the thermostat the low capacity compressor output (BO2) will be enabled and the variable speed ECM blower will operate in medium speed. When the control receives a Y2 command (BI-8) from the thermostat the full capacity compressor output will be enabled and the variable speed ECM blower will operate in high speed. During the cooling cycle the reversing valve will be commanded into the “ON” position.

Variable Speed ECM Blower Operation

Blower speeds will be selected through the user interface or the facility management system. There will be a total of 12 speeds selectable with only three being selected at any one time. The lowest numbered speed selection set to ON will select the low-speed blower setting, the middle selection set to ON will select the medium-speed blower setting and the highest selection set to ON will select the high-speed blower setting. If all selections are set to OFF

Controls - FX10 (optional) cont.

the software shall select speed setting 10 for low-speed, 11 for medium-speed, and will select speed setting 12 for high speed. If only one selection is set to ON, that selection will set the low-speed blower setting, the medium-speed setting will be 11, and the high-speed setting will be speed 12. The maximum low-speed setting will be speed 10 and the minimum high-speed setting will be speed 3. In addition there is a low limit setting in the software to prevent the variable speed ECM blower speed from being set below acceptable limits for each unit size.

Emergency Heat/Network Enabled Output (BO-5)

This output is set from the factory to enable/disable emergency heat. If a problem occurs with the unit resulting in the compressor being locked out in heating mode, the control will automatically enable this output to turn on field installed electric heat. This output is interlocked with the blower proving input BI-6 (Blower proving sensors must be field supplied and installed). BI-6 must be connected to PB2 position 3 (see unit schematic) in the field if no blower proving sensor is desired. There is a configurable parameter available through a BAS network that must be enabled if this output is to be commanded over the BAS network. **NOTE:** For auto switch over, BO-5 must be set to "Emergency" using the MUI.

MUI Alarm History Reporting

If a fault occurs the fault will be recorded in history for display on the medium user interface in the History Menu. Each fault type will be displayed in the history menu with a number between 0 and 3. A reading of 3+ will mean that fault has occurred more than three times in the past. The history menu can be cleared with a power cycle only. Alarm date and time are not included in the history.

Inputs and Outputs Configuration

Field Selectable Options

Freeze Detection Set Point (BI-5)

The freeze detection set point input allows you to adjust the freeze detection set point (AI-5). When the jumper is installed on BI-5 (Wire #24) the freeze detection set point is factory set for 30°F (-1°C). When the jumper on BI-5 (Wire #24) is removed the freeze detection set point will be 15°F (-9°C).

Accessory Outputs (BO-7 and BO-8)

Accessory Output 1 will be energized 90 seconds prior to the compressor output being energized. Accessory Output 2 will be energized with the blower output (BO-1). When the corresponding compressor output is turned off the accessory output will be deactivated immediately. These outputs are selectable for normally open or normally closed operation through the MUI or through the BAS.

FX10 User Interface (MUI) Physical Layout

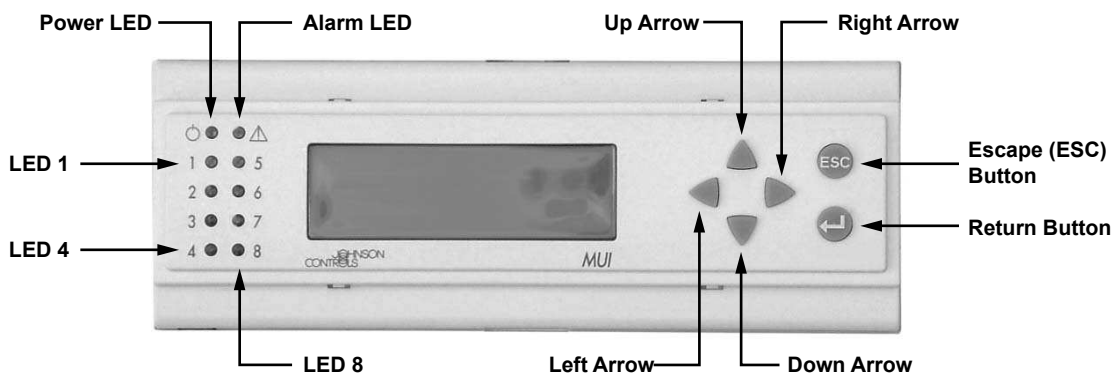

- Alarm LED** - Indicates a **Lock-Out** or a bad **Freeze Sensor**
- Power LED** - Shows FX processor is operational
- LED 1** - Flashing shows **Compressor 1** running
- LED 2** - Flashing shows **Full Capacity Compressor** running

- LED 3** - On shows **Fan** running
- LED 4** - On shows **Reversing Valve** in cool
- LED 8** - Flashing shows unit in '**Test**' Mode

Controls - FX10 (optional) cont.

MUI Menu Navigation for Single Compressor - Aston Compact Series Water-to-Air

Welcome

Info Status Temps Outputs Settings Maint Alarms Alm-History

Info

Water Source
Heat Pump
PROFXENV-XX
//_

Status

Run Mode	Auto
Eff Occup'y	Occ
Y1 Input	OFF
Y2 Input	OFF
G Input	OFF
O Input	Heat/Cool
Occ Input	Occ
Temp Occ Inp	OFF
Condensate	NML
Emg Input	Run
Lo Press	ON
Hi Press	ON
Rndm Tmr	0
BI-4 Input	OFF

Temps

Zone Temp	77.2 °F
Dis Air Temp	51.0 °F
Eff Clg Setpt	70.0°F
Eff Htg Setpt	66.0°F
Water Coil	77.8°F
Low WC Limit	30.0°F
Humidity	56.7 %RH
WarmCool AI	14.6
WarmCoolAdj	0.2

Outputs

nvoFanStatus	ON
CmpCmd Status	OFF
Cmp Capacity	OFF
Rev Valve	Heat
X1 Output	OFF
X2 Output	OFF
PWMOut	98%
BO5	OFF
BO9	OFF
AO2 Output	0%

Settings

Unit of Measure	F
Occ Clg Setpt	73.9 °F
Occ Htg Setpt	69.9 °F
Unocc Clg	84.0 °F
Unocc Htg	60.0 °F
DeHumSetpt	0%
SensorSelect	TAXXJ02

Maintenance

MinClgSetpt	60.0 °F
MaxHtgSetpt	89.9 °F
W Coil LoLim1	30.0 °F
W Coil LoLim2	15.0 °F
TmpOccTime	120 min
Rev Vlv	Default Heating
BO5 Mode	Network
CompStrtDly	90 sec
SpaceT Offset	-1 °F
DehumEnaDis	Dis
Acc1 Action	On Comp
Acc2 Action	On Fan

Press right arrow key
one time from
Maintenance Menu

ECM

SW1	OFF
SW2	OFF
SW3	ON
SW4	OFF
SW5	OFF
SW6	OFF
SW7	ON
SW8	OFF
SW9	OFF
SW10	ON
SW11	OFF
SW12	OFF

No more than three
speeds should be "ON"
at one time

Alarms

ALARM SUMMARY
^/High Pressure

Alm-History

Alarm	#Events
Condensate	0
Hi Pressure	0
Low Pressure	0
Low Temp	0
Bad Sensor	0

NOTE: This FX10 application implements an **alarm history** which is reset only by cycling power . This history shows on the Alm-History page. Any alarm showing 4+ events has occurred more than 4 times.

Alarm lock-outs are reset by cycling power, by pressing the "ESC" and Return  keys simultaneously for a minimum of 15 seconds, or by commanding the nviAlarmReset over the BAS network.

Test mode is enabled by holding the 'Esc' and Down Arrow simultaneously for a minimum of 15 seconds and releasing. Test mode times out after 30 minutes, and may also be ended by pressing 'ESC' and Up Arrow simultaneously and releasing. Test Mode bypasses the On Delay (90 sec) and Random Start timers for quicker troubleshooting. It also allows cycling the reversing valve without compressor shutdown.

Unit Startup

Before Powering Unit, Check The Following:

NOTE: Remove and discard the compressor shipping bolts. The bolts can then be discarded.

- High voltage is correct and matches nameplate.
- Fuses, breakers and wire size correct.
- Low voltage wiring complete.
- Piping completed and water system cleaned and flushed.
- Air is purged from closed loop system.
- Isolation valves are open, water control valves or loop pumps wired.
- Condensate line open and correctly pitched.
- Transformer switched to 208V if applicable.
- Dip switches are set correctly.
- Blower rotates freely – foam shipping support has been removed.
- Blower speed correct.
- Air filter/cleaner is clean and in position.
- Service/access panels are in place.
- Return air temperature is between 50-80°F heating and 60-95°F cooling.
- Check air coil cleanliness to insure optimum performance. Clean as needed according to maintenance guidelines. To obtain maximum performance the air coil should be cleaned before startup. A 10-percent solution of dishwasher detergent and water is recommended for both sides of coil, a thorough water rinse should follow.

Startup Steps

NOTE: Complete the Equipment Start-Up/Commissioning Check Sheet during this procedure. Refer to thermostat operating instructions and complete the startup procedure.

1. Initiate a control signal to energize the blower motor. Check blower operation.
2. Initiate a control signal to place the unit in the cooling mode. Cooling setpoint must be set below room temperature.
3. Cooling will energize after a time delay. Check for correct rotation of scroll compressors in 3 phase applications. Incorrect rotation will cause low refrigerant pressures and possibly unusual noise. Switch any two power leads at the line voltage supply.
4. Be sure that the compressor and water control valve or loop pump(s) are activated.
5. Verify that the water flow rate is correct by measuring the pressure drop through the heat exchanger using the P/T plugs and comparing to the pressure drop table.
6. Check the temperature of both the supply and discharge water (Refer to Operating Parameters tables).
7. Check for an air temperature drop of 15°F to 25°F across the air coil, depending on the blower speed and entering water temperature.
8. Decrease the cooling set point several degrees and verify high-speed blower operation (variable speed ECM only).
9. Adjust the cooling setpoint above the room temperature and verify that the compressor and water valve or loop pumps deactivate.
10. Initiate a control signal to place the unit in the heating mode. Heating set point must be set above room temperature.
11. Heating will energize after a time delay.
12. Check the temperature of both the supply and discharge water (Refer to Unit Operating Parameters tables).
13. Check for an air temperature rise of 20°F to 35°F across the air coil, depending on the blower speed and entering water temperature.
14. If auxiliary electric heaters are installed, increase the heating setpoint until the electric heat banks are sequenced on. All stages of the auxiliary heater should be sequenced on when the thermostat is in the Emergency Heat mode. Check amperage of each element.
15. Adjust the heating setpoint below room temperature and verify that the compressor and water valve or loop pumps deactivate.
16. During all testing, check for excessive vibration, noise or water leaks. Correct or repair as required.
17. Set system to desired normal operating mode and set temperature to maintain desired comfort level.
18. Instruct the owner/operator in the proper operation of the thermostat and system maintenance.

NOTE: Be certain to fill out and forward all warranty registration papers.

Operating Limits

Operating Limits	Cooling		Heating	
	(°F)	(°C)	(°F)	(°C)
Air Limits				
Min. Ambient Air	45	7.2	45	7.2
Rated Ambient Air	80	26.7	70	21.1
Max. Ambient Air	100	37.8	85	29.4
Min. Entering Air	50	10.0	40	4.4
Rated Entering Air db/wb	80.6/66.2	27/19	68	20.0
Max. Entering Air db/wb	110/83	43/28.3	80	26.7
Water Limits				
Min. Entering Water	30	-1.1	20	-6.7
Normal Entering Water	50-110	10-43.3	30-70	-1.1
Max. Entering Water	120	48.9	90	32.2

NOTE: Minimum/maximum limits are only for start-up conditions, and are meant for bringing the space up to occupancy temperature. Units are not designed to operate at the minimum/maximum conditions on a regular basis. The operating limits are dependant upon three primary factors: 1) water temperature, 2) return air temperature, and 3) ambient temperature. When any of the factors are at the minimum or maximum levels, the other two factors must be at the normal level for proper and reliable unit operation.

Operating Parameters

Single Speed Models

Entering Water Temp °F	Water Flow gpm/ton	Cooling -- No Hot Water Generation					
		Suction Pressure psig	Discharge Pressure psig	Superheat	Subcooling	Water Temp Rise °F	Air Temp Drop °F DB
30	1.5	115 - 125	150 - 170	20 - 35	10 - 17	17 - 22	17 - 23
	3.0	105 - 120	130 - 145	20 - 35	10 - 17	8 - 10	17 - 23
50	1.5	130 - 140	215 - 235	12 - 20	8 - 14	16 - 22	17 - 23
	3.0	128 - 138	190 - 210	12 - 20	8 - 14	8 - 12	17 - 23
70	1.5	138 - 148	280 - 310	10 - 16	10 - 16	15 - 21	17 - 23
	3.0	136 - 146	250 - 280	10 - 16	8 - 14	7 - 13	17 - 23
90	1.5	145 - 155	350 - 380	9 - 14	10 - 16	14 - 20	17 - 23
	3.0	143 - 153	320 - 350	9 - 14	8 - 14	6 - 10	17 - 23
110	1.5	145 - 155	420 - 450	9 - 14	10 - 16	14 - 20	17 - 23
	3.0	143 - 153	405 - 435	9 - 14	8 - 14	6 - 10	17 - 23
Entering Water Temp °F	Water Flow gpm/ton	Heating - No Hot Water Generation					
		Suction Pressure psig	Discharge Pressure psig	Superheat	Subcooling	Water Temp Drop °F	Air Temp Rise °F DB
30	1.5	73 - 85	270 - 305	8 - 14	3 - 10	6 - 10	15 - 21
	3.0	77 - 90	280 - 315	8 - 14	3 - 10	4 - 8	17 - 23
50	1.5	97 - 110	290 - 325	10 - 16	3 - 10	9 - 13	22 - 28
	3.0	102 - 115	300 - 335	10 - 16	3 - 10	7 - 11	24 - 30
70	1.5	130 - 145	320 - 355	13 - 19	3 - 10	10 - 14	30 - 36
	3.0	135 - 150	325 - 360	13 - 19	3 - 10	8 - 12	32 - 38
90	1.5	150 - 160	350 - 390	13 - 19	3 - 10	10 - 14	30 - 36
	3.0	155 - 165	365 - 405	13 - 19	3 - 10	8 - 12	32 - 38
110	1.5						
	3.0						

NOTE: Cooling performance based on entering air temperatures of 80° F DB, 67° F WB.
Heating performance based on entering air temperature of 70° F DB.

2/15/12

Operating Parameters cont.

Dual Capacity Models

First Stage Operation

Entering Water Temp °F	Water Flow gpm/ton	Cooling -- No Hot Water Generation					
		Suction Pressure psig	Discharge Pressure psig	Superheat	Subcooling	Water Temp Rise °F	Air Temp Drop °F DB
30	1.5	105 - 120	140 - 155	20 - 35	9 - 17	17 - 21	17 - 23
	3.0	100 - 115	115 - 130	20 - 35	9 - 17	8 - 12	17 - 23
50	1.5	125 - 140	205 - 225	12 - 20	8 - 14	17 - 21	17 - 23
	3.0	120 - 135	180 - 200	12 - 20	8 - 14	8 - 12	17 - 23
70	1.5	135 - 145	280 - 290	10 - 16	8 - 14	16 - 20	17 - 23
	3.0	133 - 143	250 - 260	10 - 16	8 - 14	9 - 13	17 - 23
90	1.5	142 - 152	345 - 355	8 - 12	8 - 14	14 - 20	17 - 23
	3.0	140 - 150	330 - 340	8 - 12	8 - 14	8 - 12	17 - 23
110	1.5	152 - 158	405 - 435	8 - 12	8 - 14	14 - 20	17 - 23
	3.0	148 - 153	390 - 420	8 - 12	8 - 14	8 - 12	17 - 23

Entering Water Temp °F	Water Flow gpm/ton	Heating -- No Hot Water Generation					
		Suctio Pressure psig	Discharge Pressure psig	Superheat	Subcooling	Water Temp Drop °F	Air Temp Rise °F DB
30	1.5	76 - 84	270 - 285	8 - 12	3 - 10	5 - 9	12 - 16
	3.0	80 - 88	275 - 290	8 - 12	3 - 10	3 - 7	14 - 18
50	1.5	100 - 115	280 - 310	10 - 14	3 - 10	7 - 11	18 - 22
	3.0	105 - 120	290 - 315	10 - 14	3 - 10	5 - 9	20 - 24
70	1.5	135 - 150	310 - 325	12 - 16	3 - 10	8 - 12	24 - 28
	3.0	140 - 155	315 - 330	12 - 16	3 - 10	6 - 10	22 - 30
90	1.5	155 - 165	330 - 370	12 - 16	3 - 10	8 - 12	24 - 28
	3.0	160 - 170	340 - 380	12 - 16	3 - 10	6 - 10	22 - 30
110	1.5						
	3.0						

NOTE: Cooling performance based on entering air temperatures of 80° F DB, 67° F WB.
Heating performance based on entering air temperature of 70° F DB.

2/15/12

Second Stage Operation

Entering Water Temp °F	Water Flow gpm/ton	Cooling -- No Hot Water Generation					
		Suction Pressure psig	Discharge Pressure psig	Superheat	Subcooling	Water Temp Rise °F	Air Temp Drop °F DB
30	1.5	115 - 125	150 - 170	20 - 35	10 - 17	17 - 22	17 - 23
	3.0	105 - 120	130 - 145	20 - 35	10 - 17	8 - 10	17 - 23
50	1.5	130 - 140	215 - 235	12 - 20	8 - 14	16 - 22	17 - 23
	3.0	128 - 138	190 - 210	12 - 20	8 - 14	8 - 12	17 - 23
70	1.5	138 - 148	280 - 310	10 - 16	10 - 16	15 - 21	17 - 23
	3.0	136 - 146	250 - 280	10 - 16	8 - 14	7 - 13	17 - 23
90	1.5	145 - 155	350 - 380	9 - 14	10 - 16	14 - 20	17 - 23
	3.0	143 - 153	320 - 350	9 - 14	8 - 14	6 - 10	17 - 23
110	1.5	145 - 155	420 - 450	9 - 14	10 - 16	14 - 20	17 - 23
	3.0	143 - 153	405 - 435	9 - 14	8 - 14	6 - 10	17 - 23

Entering Water Temp °F	Water Flow gpm/ton	Heating -- No Hot Water Generation					
		Suction Pressure psig	Discharge Pressure psig	Superheat	Subcooling	Water Temp Drop °F	Air Temp Rise °F DB
30	1.5	73 - 85	270 - 305	8 - 14	3 - 10	6 - 10	15 - 21
	3.0	77 - 90	280 - 315	8 - 14	3 - 10	4 - 8	17 - 23
50	1.5	97 - 110	290 - 325	10 - 16	3 - 10	9 - 13	22 - 28
	3.0	102 - 115	300 - 335	10 - 16	3 - 10	7 - 11	24 - 30
70	1.5	130 - 145	320 - 355	13 - 19	3 - 10	10 - 14	30 - 36
	3.0	135 - 150	325 - 360	13 - 19	3 - 10	8 - 12	32 - 38
90	1.5	150 - 160	350 - 390	13 - 19	3 - 10	10 - 14	30 - 36
	3.0	155 - 165	365 - 405	13 - 19	3 - 10	8 - 12	32 - 38
110	1.5						
	3.0						

NOTE: Cooling performance based on entering air temperatures of 80° F DB, 67° F WB.
Heating performance based on entering air temperature of 70° F DB.

2/15/12

Pressure Drop

Single Speed

Model	gpm	Pressure Drop (psi)				
		30°F	50°F	70°F	90°F	110°F
009	1.5	1.9	1.8	1.7	1.6	1.5
	2.0	3.5	3.4	3.2	3.1	3.0
	3.0	6.9	6.5	6.3	6.0	5.7
	4.0	12.0	11.4	11.0	10.8	10.5
012	1.5	0.3	0.3	0.3	0.3	0.3
	2.5	1.0	1.0	1.0	1.0	1.0
	3.5	1.7	1.7	1.7	1.6	1.6
	4.5	2.5	2.4	2.4	2.4	2.3
015	2.0	0.6	0.6	0.6	0.6	0.6
	3.0	1.6	1.6	1.6	1.6	1.6
	4.0	2.6	2.6	2.6	2.6	2.5
	5.0	3.7	3.7	3.6	3.6	3.5
018	3.0	1.6	1.6	1.5	1.5	1.4
	4.0	2.9	2.9	2.8	2.8	2.7
	5.0	4.2	4.2	4.1	4.0	3.9
	6.0	6.0	5.8	5.7	5.6	5.5
024	3.0	1.1	1.1	0.9	0.8	0.6
	4.5	2.1	2.0	1.8	1.7	1.5
	6.0	4.1	4.0	3.8	3.7	3.5
	8.0	4.5	4.4	4.1	3.9	3.7
030	4.0	1.5	1.4	1.3	1.2	1.1
	6.0	3.0	2.8	2.7	2.5	2.3
	8.0	5.1	4.8	4.5	4.2	3.9
	10.0	7.7	7.2	6.8	6.3	5.8
036	5.0	1.0	1.0	0.9	0.8	0.8
	7.0	2.1	1.9	1.8	1.7	1.6
	9.0	3.6	3.3	3.0	2.8	2.6
	12.0	6.3	5.9	5.5	5.1	4.8
042	5.0	0.8	0.7	0.7	0.7	0.6
	8.0	2.1	2.1	1.9	1.8	1.7
	11.0	4.2	4.1	3.8	3.5	3.3
	14.0	7.6	6.7	6.3	5.8	5.4
048	6.0	1.1	1.0	1.0	0.9	0.8
	9.0	2.3	2.1	2.0	1.9	1.7
	12.0	3.9	3.7	3.4	3.2	3.0
	16.0	6.7	6.3	5.9	5.5	5.1
060	9.0	2.4	2.2	2.1	2.0	1.8
	12.0	3.9	3.6	3.4	3.2	2.9
	15.0	5.7	5.3	5.0	4.7	4.3
	20.0	9.5	8.9	8.3	7.8	7.2
070	12.0	3.0	2.8	2.6	2.4	2.2
	15.0	4.4	4.0	3.8	3.5	3.3
	18.0	6.0	5.5	5.1	4.8	4.4
	24.0	9.7	9.1	8.5	7.9	7.3

3/16/12

Valve	gpm	Cv	Pressure Drop (psi)
1/2 in.	1.5	9.6	0.02
	2.0	9.7	0.04
	3.0	9.9	0.09
	4.0	10.1	0.16
1/2 in.	1.5	9.6	0.02
	2.5	9.8	0.06
	3.5	10.0	0.12
	4.5	10.2	0.19
3/4 in.	2.0	9.7	0.04
	3.0	9.9	0.09
	4.0	10.1	0.16
	5.0	10.4	0.23
3/4 in.	3.0	9.9	0.09
	4.0	10.1	0.16
	5.0	10.4	0.23
	6.0	10.6	0.32
3/4 in.	3.0	9.9	0.09
	4.5	10.2	0.19
	6.0	10.6	0.32
	8.0	11.0	0.53
3/4 in.	4.0	10.1	0.16
	6.0	10.6	0.32
	8.0	11.0	0.53
	10.0	11.5	0.76
1 in.	5.0	15.9	0.10
	7.0	16.6	0.23
	9.0	17.2	0.41
	12.0	17.9	0.61
1 in.	5.0	15.9	0.10
	8.0	16.6	0.23
	11.0	17.2	0.41
	14.0	17.9	0.61
1 in.	6.0	16.1	0.14
	9.0	16.8	0.29
	12.0	17.4	0.47
	16.0	18.3	0.76
1 in.	9.0	16.8	0.29
	12.0	17.4	0.47
	15.0	18.1	0.69
	20.0	19.2	1.09
1 in.	12.0	17.4	0.47
	15.0	18.1	0.69
	18.0	18.7	0.92
	24.0	20.1	1.43

3/16/12

Dual Capacity

Model	gpm	Pressure Drop (psi)				
		30°F	50°F	70°F	90°F	110°F
026	4.0	1.4	1.3	1.2	1.1	1.0
	6.0	2.8	2.6	2.4	2.3	2.1
	8.0	4.7	4.4	4.1	3.8	3.5
	10.0	7.0	6.6	6.2	5.8	5.3
038	5.0	1.2	1.2	1.1	1.0	1.0
	7.0	2.2	2.1	1.9	1.8	1.7
	9.0	3.4	3.2	3.0	2.8	2.6
	11.0	4.9	4.6	4.3	4	3.7
049	6.0	1.2	1.2	1.1	1.0	1.0
	9.0	2.4	2.2	2.1	2.0	1.8
	12.0	3.9	3.6	3.4	3.2	2.9
	15.0	5.7	5.3	5	4.7	4.3
064	8.0	1.8	1.7	1.6	1.4	1.3
	12.0	3.8	3.5	3.3	3.0	2.8
	16.0	6.5	6.0	5.6	5.2	4.8
	20.0	9.7	9.1	8.5	8.0	7.4
072	12.0	3.2	3.0	2.8	2.6	2.4
	15.0	4.5	4.2	4.0	3.7	3.4
	18.0	6.0	5.7	5.3	4.9	4.6
	21.0	7.8	7.3	6.8	6.4	5.9

3/16/12

Valve	gpm	Cv	Pressure Drop (psi)
3/4 in.	4.0	10.1	0.16
	6.0	10.6	0.32
	8.0	11.0	0.53
	10.0	11.5	0.76
3/4 in.	5.0	10.4	0.23
	7.0	10.8	0.42
	9.0	11.2	0.64
	12.0	11.9	1.02
1 in.	6.0	16.1	0.14
	9.0	16.8	0.29
	12.0	17.4	0.47
	15.0	18.1	0.69
1 in.	9.0	16.8	0.29
	12.0	17.4	0.47
	16.0	18.3	0.76
	20.0	19.2	1.09
1 in.	12.0	17.4	0.47
	15.0	18.1	0.69
	18.0	18.7	0.92
	24.0	20.1	1.43

3/16/12

Reference Calculations

Heating Calculations:	Cooling Calculations:
$LWT = EWT - \frac{HE}{gpm \times 500}$	$LWT = EWT + \frac{HR}{gpm \times 500}$
$LAT = EAT + \frac{HC}{cfm \times 1.08}$	$LAT(DB) = EAT(DB) - \frac{SC}{cfm \times 1.08}$
$TH = HC + HWC$	$LC = TC - SC$
	$S/T = \frac{SC}{TC}$

Legend

ABBREVIATIONS AND DEFINITIONS:

cfm	=	airflow, cubic feet/minute	HWC	=	hot water generator capacity, MBtu/h
EWT	=	entering water temperature, Fahrenheit	EER	=	Energy Efficient Ratio
gpm	=	water flow in gallons/minute		=	BTU output/Watt input
WPD	=	water pressure drop, PSI and feet of water	COP	=	Coefficient of Performance
EAT	=	entering air temperature, Fahrenheit (dry bulb/wet bulb)		=	BTU output/BTU input
HC	=	air heating capacity, MBtu/h	LWT	=	leaving water temperature, °F
TC	=	total cooling capacity, MBtu/h	LAT	=	leaving air temperature, °F
SC	=	sensible cooling capacity, MBtu/h	TH	=	total heating capacity, MBtu/h
KW	=	total power unit input, kilowatts	LC	=	latent cooling capacity, MBtu/h
HR	=	total heat of rejection, MBtu/h	S/T	=	sensible to total cooling ratio
HE	=	total heat of extraction, MBtu/h			

Refrigerant Circuit Guideline

Symptom	Head Pressure	Suction Pressure	Compressor Amp Draw	Superheat	Subcooling	Air Temp. Differential	Water Temp. Differential
Under Charged System (Possible Leak)	Low	Low	Low	High	Low	Low	Low
Over Charged System	High	High	High	Normal	High	Normal/Low	Normal
Low Air Flow Heating	High	High	High	High/Normal	Low	High	Low
Low Air Flow Cooling	Low	Low	Low	Low/Normal	High	High	Low
Low Water Flow Heating	Low/Normal	Low/Normal	Low	Low	High	Low	High
Low Water Flow Cooling	High	High	High	High	Low	Low	High
High Air Flow Heating	Low	Low	Low	Low	High	Low	Low
High Air Flow Cooling	Low	High	Normal	High	Low	Low	Normal
High Water Flow Heating	Normal	Low	Normal	High	Normal	Normal	Low
High Water Flow Cooling	Low	Low	Low	Low	High	Normal	Low
Low Indoor Air Temperature Heating	Low	Low	Low	Normal	High	Normal	Normal/High
Low Indoor Air Temperature Cooling	Low	Low	Low	Normal/Low	High	Low	Low
High Indoor Air Temperature Heating	High	High	High	Normal/High	Normal/Low	Low	Normal
High Indoor Air Temperature Cooling	High	High	High	High	Low	Low	High
Restricted TXV (Check Service Advisory)	High	Low	Normal/Low	High	High	Low	Low
Insufficient Compressor (Possible Bad Valves)	Low	High	Low	High	Normal/High	Low	Low
TXV - Bulb Loss of Charge	Low	Low	Low	High	High	Low	Low
Scaled Coaxial Heat Exchanger Heating	Low	Low	Low	Normal/Low	High	Low	Low
Scaled Coaxial Heat Exchanger Cooling	High	High	High	Normal/Low	Low	Low	Low
Restricted Filter Drier	Check temperature difference (delta T) across filter drier.						

7/6/10

Compressor Resistance

Model	208-230/60/1		265/60/1		208-230/60/3	460/60/3	575/60/3	
	Run	Start	Run	Start				
Single Speed	009	3.65 - 4.19	3.75 - 4.31	3.73 - 4.27	4.45 - 5.13	n/a	n/a	n/a
	012	3.35 - 3.85	2.80 - 3.22	3.73 - 4.27	4.45 - 5.13	n/a	n/a	n/a
	015	2.74 - 3.16	2.60 - 3.00	3.03 - 3.49	2.39 - 2.75	n/a	n/a	n/a
	018	2.24 - 2.58	2.84 - 3.26	3.03 - 3.49	2.39 - 2.75	n/a	n/a	n/a
	024	1.21 - 1.39	1.53 - 1.75	1.38 - 1.58	2.02 - 2.32	2.00 - 2.30	8.00 - 9.20	n/a
	030	1.21 - 1.39	1.53 - 1.75	1.38 - 1.58	2.02 - 2.32	2.00 - 2.30	8.00 - 9.20	n/a
	036	0.95 - 1.09	1.81 - 2.09	1.24 - 1.42	2.42 - 2.78	1.77 - 2.04	7.57 - 8.71	n/a
	042	0.83 - 0.95	1.54 - 1.78	n/a		1.42 - 1.64	5.46 - 6.28	8.26 - 9.50
	048	0.51 - 0.59	1.13 - 1.31	n/a		0.96 - 1.10	3.88 - 4.46	5.88 - 6.76
	060	0.42 - 0.48	0.73 - 0.85	n/a		0.63 - 0.73	2.98 - 3.42	4.96 - 5.70
070	0.33 - 0.39	0.90 - 1.04	n/a		0.56 - 0.64	2.34 - 2.70	3.48 - 4.00	
Dual Capacity	026	1.21 - 1.39	1.52 - 1.75	1.38 - 1.58	2.02 - 2.32	2.00 - 2.30	8.00 - 9.20	n/a
	038	0.82 - 0.94	1.41 - 1.63	1.13 - 1.31	1.07 - 1.23	1.42 - 1.64	5.46 - 6.28	n/a
	049	0.48 - 0.56	1.73 - 1.99	n/a		0.96 - 1.10	3.88 - 4.46	n/a
	064	0.36 - 0.42	1.52 - 1.74	n/a		0.63 - 0.73	2.98 - 3.42	n/a
	072	0.32 - 0.36	1.72 - 1.98	n/a		0.56 - 0.64	2.34 - 2.70	n/a

3/16/12

Thermistor Resistance

Thermistor Temperature (°F)	Microprocessor Resistance (Ohms)	FX10 Resistance (Ohms)
5	75757-70117	746-770
14	57392-53234	775-803
23	43865-40771	808-836
32	33809-31487	841-869
41	26269-24513	875-903
50	20570-19230	910-938
59	16226-15196	946-974
68	12889-12093	981-1013
77	10310-9688	1019-1051
86	8300-7812	1058-1090
95	6723-6337	1097-1129
104	5480-5172	1137-1169
113	4490-4246	1179-1211
122	3700-3504	1221-1253
131	3067-2907	1261-1297
140	2554-2424	1305-1341
149	2149-2019	1350-1386

7/6/10

Heat of Extraction/Rejection Data

Single Speed

Model	gpm	Heat of Extraction (HE) - MBtu/h				Heat of Rejection (HR) - MBtu/h				
		30°F	50°F	70°F	90°F	30°F	50°F	70°F	90°F	110°F
009	1.5		6.5	8.6	11.3		13.0	12.4	12.1	
	2.0	5.1	6.7	8.9	11.6	13.3	13.0	12.4	12.1	11.9
	3.0	5.0	7.1	9.3	11.8	12.9	13.1	12.4	11.6	11.1
012	1.5		7.4	9.6	12.5		16.9	16.5	15.8	
	2.5	5.9	7.7	10.1	12.7	17.3	16.9	16.4	15.9	16.0
	3.5	6.1	8.1	10.6	12.9	17.4	16.9	16.4	16.0	16.1
015	2.0		9.7	12.4	15.7		19.3	18.3	17.6	
	3.0	7.9	10.1	13.0	16.4	18.0	19.4	18.3	17.6	17.3
	4.0	8.0	10.5	13.5	16.5	17.1	19.5	18.4	17.6	16.7
018	3.0		11.4	13.9	19.1		23.0	21.6	20.5	
	4.0	10.1	12.2	14.8	19.5	21.1	23.3	21.7	20.5	20.1
	5.0	10.4	13.1	15.8	19.8	21.2	23.6	21.9	20.7	20.1
024	3.0		17.4	22.8	28.5		32.6	31.8	29.4	
	4.5	13.8	18.1	23.5	29.0	29.8	32.6	31.8	29.8	28.5
	6.0	13.4	18.8	24.3	29.4	30.0	32.6	31.9	30.1	28.7
030	4.0		20.0	26.0	31.0		35.1	35.4	33.1	
	6.0	14.6	20.8	27.1	32.3	32.6	35.0	35.3	33.0	29.3
	8.0	14.9	21.3	27.6	32.8	32.9	35.3	35.5	33.2	29.4
036	5.0		23.8	31.3	37.6		41.5	42.7	40.8	
	7.0	17.7	24.9	32.6	39.2	34.9	41.4	42.6	40.7	38.0
	9.0	18.1	25.5	33.2	39.8	35.3	41.8	42.9	40.9	38.2
042	5.0		27.2	33.7	40.0		50.2	51.2	48.8	
	8.0	21.0	28.5	35.5	42.4	46.9	50.4	51.5	49.1	45.9
	11.0	21.4	29.3	36.6	43.9	47.2	50.7	51.8	49.3	45.9
048	6.0		35.1	43.9	51.2		60.6	60.5	57.0	
	9.0	26.8	36.7	46.3	54.3	56.2	60.8	60.9	57.4	53.8
	12.0	27.3	37.7	47.7	56.2	56.5	61.1	61.1	57.5	53.8
060	9.0		44.1	56.3	65.1		83.1	81.3	76.5	
	12.0	31.5	45.5	57.5	69.1	80.2	82.9	81.6	76.3	71.9
	15.0	32.6	46.4	59.9	70.0	80.8	83.2	81.2	76.5	72.0
070	12.0		52.4	66.9	78.1		91.1	89.5	83.0	
	15.0	37.9	53.7	69.8	82.9	83.4	91.2	89.4	82.7	76.8
	18.0	38.1	54.3	70.9	84.8	83.8	91.9	90.3	83.6	77.6

3/16/12

Dual Capacity

Model	gpm	Heat of Extraction (HE) - MBtu/h				Heat of Rejection (HR) - MBtu/h					
		30°F	50°F	70°F	90°F	30°F	50°F	70°F	90°F	110°F	
026	Part Load	3.0		14.0	18.8	22.8		26.7	26.6	24.3	
		5.0	10.2	14.8	19.8	24.0	24.7	26.8	26.7	24.2	22.2
		7.0	10.3	15.1	20.1	24.4	25.0	27.0	26.7	24.3	22.2
	Full Load	4.0		18.6	24.3	29.6		34.8	34.9	33.4	
		6.0	14.0	19.7	25.7	31.1	33.6	34.9	35.0	33.3	31.1
		8.0	14.3	20.1	26.1	31.7	33.9	35.1	35.1	33.4	31.1
038	Part Load	4.0		17.6	22.8	27.5		35.3	34.5	32.4	
		6.0	12.6	18.3	24.0	29.2	32.5	35.6	34.7	32.5	30.3
		8.0	13.6	19.3	24.6	29.2	33.0	36.1	35.2	32.9	30.7
	Full Load	5.0		25.1	31.4	35.9		48.3	48.5	45.8	
		7.0	18.8	26.2	33.1	38.4	45.2	48.8	49.2	46.7	43.6
		9.0	19.2	26.9	34.1	39.7	45.5	49.1	49.6	47.0	43.8
049	Part Load	5.0		23.2	28.6	32.7		47.4	48.5	46.2	
		8.0	18.4	25.6	31.7	36.5	42.9	47.5	48.3	45.6	42.2
		11.0	19.1	26.6	33.4	38.9	42.4	47.5	48.7	46.5	43.3
	Full Load	6.0		33.5	40.8	46.2		63.4	63.2	59.0	
		9.0	26.1	34.8	43.0	49.3	59.1	63.5	63.9	60.1	55.0
		12.0	26.7	35.8	44.4	51.1	59.3	63.7	64.3	60.3	55.3
064	Part Load	6.0		32.6	41.0	48.0		60.6	59.4	55.5	
		10.0	22.8	32.9	42.7	51.8	56.5	60.5	59.5	55.8	52.2
		14.0	23.9	34.1	43.6	51.9	56.3	60.5	59.6	56.1	52.5
	Full Load	8.0		43.9	56.4	69.0		81.0	82.9	76.5	
		12.0	34.5	47.0	58.9	70.2	73.7	81.5	83.4	76.7	71.4
		16.0	34.9	47.9	60.7	73.1	74.1	82.0	83.8	77.2	71.5
072	Part Load	10.0		36.8	47.0	55.3		68.4	67.9	63.2	
		13.0	25.5	37.1	49.1	59.7	62.4	68.3	67.9	63.5	58.8
		16.0	27.1	38.6	50.0	59.8	61.9	68.3	68.2	63.8	59.1
	Full Load	12.0		50.2	65.1	78.2		89.6	88.1	84.6	
		15.0	38.7	53.7	67.8	79.4	80.9	90.0	91.0	84.9	77.8
		18.0	39.1	54.7	70.0	82.7	81.5	90.6	91.5	85.3	78.1

3/16/12

Troubleshooting

Should a major problem develop, refer to the following information for possible causes and corrective steps.

If compressor won't run:

1. The fuse may be open or the circuit breaker is tripped. Check electrical circuits and motor windings for shorts or grounds. Investigate for possible overloading. Replace fuse or reset circuit breakers after fault is corrected.
2. Supply voltage may be too low. Check it with a volt meter.
3. Control system may be faulty. Check control for correct wiring of thermostat or aquastat and check the 24 volt transformer for proper voltage.
4. Wires may be loose or broken. Replace or tighten.
5. The low pressure switch may have tripped due to one or more of the following:
 - a) Heating
 - 1) Plugged heat exchanger on source side
 - 2) Water flow source side - (Low)
 - 3) Water too cold source side
 - 4) Low refrigerant
 - b) Cooling
 - 1) Plugged heat exchanger on load side
 - 2) Water flow load side - (Low)
 - 3) Water too cold load side
 - 4) Low refrigerant
6. The high pressure switch may have tripped due to one or more of the following:
 - a) Heating
 - 1) Plugged heat exchanger on load side
 - 2) Low water flow load side
 - 3) Water too warm load side
 - b) Cooling
 - 1) Plugged heat exchanger on source side
 - 2) Low water flow on source side
 - 3) Water too warm source side
7. The compressor overload protection may be open.
8. The internal winding of the compressor motor may be grounded to the compressor shell. If so, replace the compressor.
9. The compressor winding may be open or shorted. Disconnect power. Check continuity with ohm meter. If the winding is open, replace the compressor.

If sufficient cooling or heating is not obtained:

1. Check control for improper location or setting.
2. Check for restriction in water flow.
3. Check refrigerant subcooling and superheat for proper refrigerant charge and expansion valve operation.
4. The reversing valve may be defective and creating a bypass of refrigerant. If the unit will not heat, check the reversing valve coil.

If the unit operation is noisy:

1. Check compressor for loosened mounting bolts. Make sure compressor is floating free on its isolator mounts. Check for tubing contact with the compressor or other surfaces. Readjust it by bending slightly.
2. Check screws on all panels.
3. Check for chattering or humming in the contactor or relays due to low voltage or a defective holding coil. Replace the component.
4. Check for proper installation of vibration absorbing material under the unit.
5. Check for abnormally high discharge pressures.
6. Compressor rotation incorrect

Aurora Control System

NOTE: Refer to the Aurora Base Control Application and Troubleshooting Guide and the Instruction Guide: Aurora Interface and Diagnostics (AID) Tool for additional information.

To check the unit control board for proper operation:

1. Disconnect thermostat wires at the control board.
2. Jumper the desired test input (Y1, Y2, W, O or G) to the R terminal to simulate a thermostat signal.
3. If control functions properly:
 - Check for thermostat and field control wiring (use the diagnostic inputs mode).
4. If control responds improperly:
 - Ensure that component being controlled is functioning (compressor, blower, reversing valve, etc.).
 - Ensure that wiring from control to the component is functioning (refer to the LED Definition table below and use the diagnostic outputs mode).
 - If steps above check properly, replace unit control.

Refrigerant Systems

To maintain sealed circuit integrity, do not install service gauges unless unit operation appears abnormal. Compare the change in temperature on the air side as well as the water side to the Operating Parameters tables. If the unit's performance is not within the ranges listed, and the airflow and water flow are known to be correct, gauges should then be installed and superheat and subcooling numbers calculated. If superheat and subcooling are outside recommended ranges, an adjustment to the refrigerant charge may be necessary.

NOTE: Refrigerant tests must be made with hot water generator turned "OFF". Verify that air and water flow rates are at proper levels before servicing the refrigerant circuit.

Startup and Troubleshooting Form

Company Name: _____ Company Phone No: _____
 Technician Name: _____ Date: _____
 Model No: _____ Serial No: _____
 Owner's Name: _____ Open or Closed Loop: _____
 Installation Address: _____ Installation Date: _____

Check One

Start up/Check-out for new installation Troubleshooting Problem: _____

1. FLOW RATE IN GPM (COAXIAL HEAT EXCHANGER)

Water In Pressure: a. _____ PSI
 Water Out Pressure: b. _____ PSI
 Pressure Drop = a - b c. _____ PSI
 Convert Pressure Drop to Flow Rate
 (refer to *Pressure Drop* table) d. _____ GPM

2. TEMPERATURE RISE OR DROP ACROSS COAXIAL HEAT EXCHANGER

	COOLING	HEATING
Water In Temperature:	e. _____ °F	e. _____ °F
Water Out Temperature:	f. _____ °F	f. _____ °F
Temperature Difference:	g. _____ °F	g. _____ °F

3. TEMPERATURE RISE OR DROP ACROSS AIR COIL

	COOLING	HEATING
Air In Temperature:	h. _____ °F	h. _____ °F
Air Out Temperature:	i. _____ °F	i. _____ °F
Temperature Difference:	j. _____ °F	j. _____ °F

4. HEAT OF REJECTION (HR) / HEAT OF EXTRACTION (HE) CALCULATION

HR or HE = Flow Rate x Temperature Difference x Brine Factor*
 d. (above) x g. (above) x 485 for Methanol or Environol, 500 for water*
 Heat of Extraction (Heating Mode) = _____ btu/hr
 Heat of Rejection (Cooling Mode) = _____ btu/hr
 Compare results to Capacity Data Tables

Note: Steps 5 through 8 need only be completed if a problem is suspected

5. WATTS

	COOLING	HEATING
Volts:	m. _____ VOLTS	m. _____ VOLTS
Total Amps (Comp. + Fan):	n. _____ AMPS	n. _____ AMPS
Watts = m. x n. x 0.85	o. _____ WATTS	o. _____ WATTS

6. CAPACITY

Cooling Capacity = HR. - (o. x 3.413) p. _____ btu/hr
 Heating Capacity = HE. + (o. x 3.413) p. _____ btu/hr

7. EFFICIENCY

Cooling EER = p. / o. q. _____ EER
 Heating COP = p. / (o. x 3.413) q. _____ COP

8. SUPERHEAT (S.H.) / SUBCOOLING (S.C.)

	COOLING	HEATING
Suction Pressure:	r. _____ PSI	r. _____ PSI
Suction Saturation Temperature:	s. _____ °F	s. _____ °F
Suction Line Temperature:	t. _____ °F	t. _____ °F
Superheat = t. - s.	u. _____ °F	u. _____ °F
Head Pressure:	v. _____ PSI	v. _____ PSI
High Pressure Saturation Temp.:	w. _____ °F	w. _____ °F
Liquid Line Temperature*:	x. _____ °F	x. _____ °F
Subcooling = w. - x.	y. _____ °F	y. _____ °F

* Note: Liquid line is between the coaxial heat exchanger and the expansion valve in the cooling mode; between the air coil and the expansion valve in the heating mode.

Startup/Troubleshooting Form

Dealer: _____
 Phone #: _____ Date: _____
 Problem: _____
 Model #: _____
 Serial #: _____

Controls Info:
 ABC Version: _____
 AXB Version: _____
 IZ2 Version: _____
 T-Stat Version: _____
 Installed Sensors: _____

COOLING CYCLE ANALYSIS

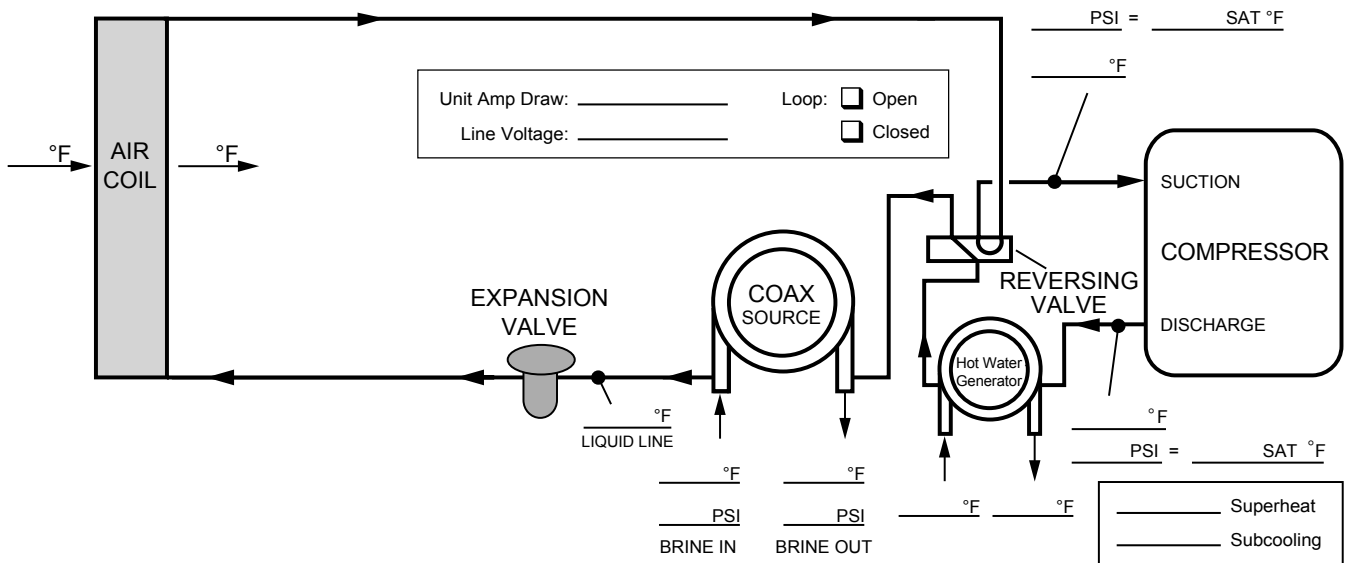

Heat of Extraction/Rejection = gpm x 500 (485 for water/antifreeze) x ΔT

Note: DO NOT hook up pressure gauges unless there appears to be a performance problem.

HEATING CYCLE ANALYSIS

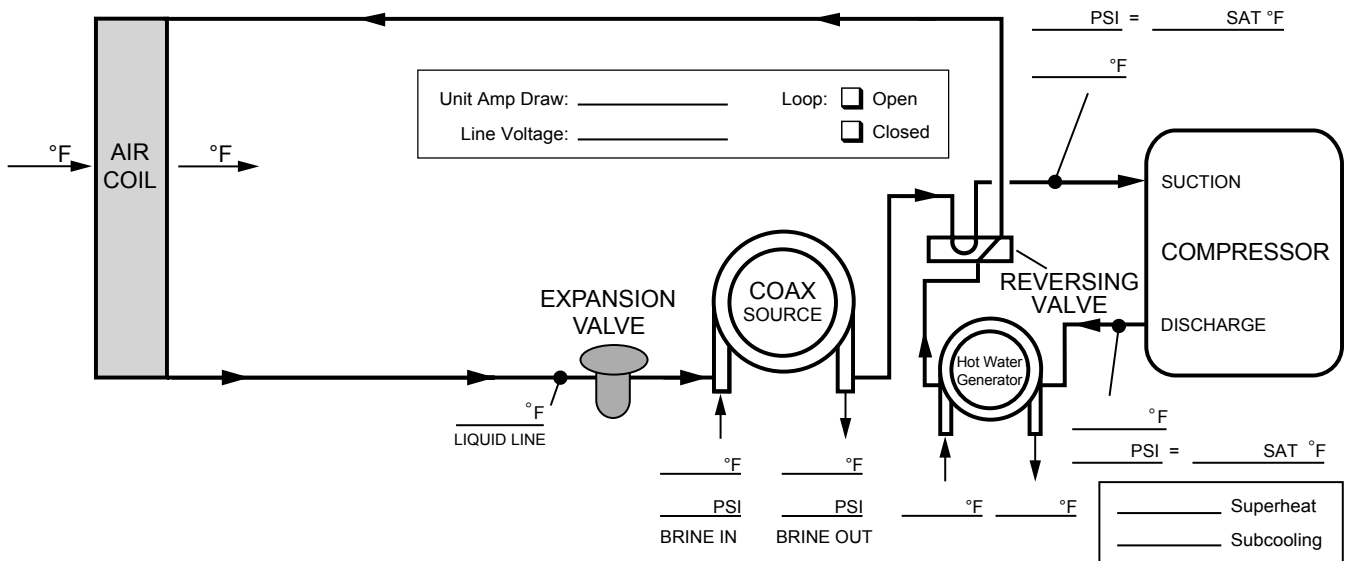

Preventive Maintenance

Water Coil Maintenance

1. Keep all air out of the water. An open loop system should be checked to ensure that the well head is not allowing air to infiltrate the water line. Lines should always be airtight.
2. Keep the system under pressure at all times. It is recommended in open loop systems that the water control valve be placed in the discharge line to prevent loss of pressure during off cycles. Closed loop systems must have positive static pressure.

NOTE: On open loop systems, if the installation is in an area with a known high mineral content (125 PPM or greater) in the water, it is best to establish with the owner a periodic maintenance schedule so the coil can be checked regularly. Should periodic coil cleaning be necessary, use standard coil cleaning procedures which are compatible with either the cupronickel or copper water lines. Generally, the more water flowing through the unit the less chance for scaling.

Other Maintenance

Filters

Filters must be clean to obtain maximum performance. They should be inspected monthly under normal operating conditions and be replaced when necessary. Units should never be operated without a filter.

Condensate Drain

In areas where airborne bacteria produce a slime in the drain pan, it may be necessary to treat chemically to minimize the problem. The condensate drain can pick up lint and dirt, especially with dirty filters. Inspect twice a year to avoid the possibility of overflow.

Blower Motors

Blower motors are equipped with sealed ball bearings and require no periodic oiling.

Hot Water Generator Coil

See Water Coil Maintenance section above.

Air Coil

The air coil must be cleaned to obtain maximum performance. Check once a year under normal operating conditions and, if dirty, brush or vacuum (with a brush attachment) clean. Care must be taken not to damage the aluminum fins while cleaning.



CAUTION: Fin edges are sharp.

Replacement Parts

Obtaining Parts

When ordering service or replacement parts, refer to the model number and serial number of the unit as stamped on the serial plate attached to the unit. If replacement parts are required, mention the date of installation of the unit and the date of failure, along with an explanation of the malfunctions and a description of the replacement parts required.

In-Warranty Material Return

Material may not be returned except by permission of authorized warranty personnel. Contact your local distributor for warranty return authorization and assistance.

Service Parts

Part Description		Single Speed Vertical Units											
		009	012	015	018	024	030	036	042	048	060	070	
Compressor	Compressor 208-230/60/1	34P590-01	34P591-01	34P592-01	34P593-01	34P624-01	34P582-01	34P583-01	34P578-01	34P579-01	34P580-01	34P646-01	
	265/60/1	34P590-02	34P591-02	34P592-02	34P593-02	34P624-02	34P582-02	34P583-02	Not Available				
	230/60/3	Not Available				34P624-03	34P582-03	34P583-03	34P578-03	34P579-03	34P580-03	34P646-03	
	460/60/3	Not Available				34P624-04	34P582-04	34P583-04	34P578-04	34P579-04	34P580-04	34P646-04	
	575/60/3	Not Available				Not Available			34P578-05	34P579-05	34P580-05	34P646-05	
	Run Capacitor 208-230/60/1	16P002D17	16P002D18	16P002D19	16P002D19	16P002D19	16P002D20		16P002D21		16P002D25	16P002D24	
	Sound Jacket	92P504A01				92P504A05							92P504A03
	Power Harness	11P521A01				11P781-01							
	Solenoid Harness	Not Available											
VS ECM Motor & Blower	VS ECM Motor 208-230/60/1	Not Available			14S551-01			14S552-01			14S553-01		
	VS ECM Motor 265/60/1	Not Available			14S551-02			14S552-02			Not Available		
	VS ECM Motor 230/60/3	Not Available			14S551-01			14S552-01			14S553-01		
	VS ECM Motor 460/60/3	Not Available				14S551-02			14S552-02			14S553-02	
	VS ECM Blower Housing	Not Available			53P512B01			53P515B01					
	VS ECM Harness	Not Available			11P607B02								
	VS ECM Power Harness	Not Available			11P585B02								
High Static VS ECM Motor & Blower	High Static VS ECM Motor 208-230/60/1	Not Available					14S553-01		14S553-01	14S553-01	Not Available		
	High Static VS ECM Motor 265/60/1	Not Available					14S553-02		Not Available				
	High Static VS ECM Motor 230/60/3	Not Available					14S553-01		14S553-01	14S553-01	Not Available		
	High Static VS ECM Motor 460/60/3	Not Available					14S553-02		14S553-02	14S553-02	Not Available		
5-Speed ECM Motor & Blower	5-Spd ECM Motor 208-230/60/1	Not Available			14P536-01			14P537-01					
	5-Spd ECM Motor 265/60/1	Not Available			14P536-02			14P537-02					
	5-Spd ECM Motor 230/60/3	Not Available			14P536-01			14P537-01					
	5-Spd ECM Motor 460/60/3	Not Available			14P536-03			14P537-03					
	5-Spd ECM Blower Housing	Not Available			53P512B01			53P515B01					
PSC Motor & Blower	PSC Motor 208-230/60/1	14P506-02		14P507B01		14P508B01	14P509B01	14P510B01	14P511B01		14P514B01		
	PSC Motor 265/60/1	14P506-02		14P507B02		14P508B02	14P509B02	14P510B02	Not Available				
	PSC Motor 230/60/3	Not Available				14P508B01	14P509B01	14P510B01	14P511B01		14P514B01		
	PSC Motor 460/60/3	Not Available				14P508B03	14P509B03	14P510B03	14P511B02		14P514B02		
	PSC Motor 575/60/3	Not Available				Not Available			14P511B03		14P514B03		
	PSC Blower & Housing	53P502B01			53P512B01			53P517-02		53P515B01			
Refrigeration Components	Air Coil	61P600-11	61P601-11	61P602-11		61P603-11	61P648-11	61S605-11	61S606-11		61P701-11		
	Coax	62P586-01	62P572-01	62P585-01		62P566-01	62P588-01	62P574-01	62P574-01	62P543-04	62P543-04	62P557-01	
	TXV	33P605-08	33P608-13	33P608-02	33P608-02	33P619-02		33P619-03		33P619-04	33P619-05		
	Reversing Valve	33P502-05				33P506-04		33P503-05		33P526-05			
	Filter Drier	Not Available				36P500B01							
HWG	Hot Water Generator	Not Available			62P516-05				62P516-03				
Controls	Contactors	Not Available					13P004A03						
	Transformer 208-230/60/1	Not Available					15P501B01						
	Transformer 265/60/1	Not Available					15P507B01			Not Available			
	Transformer 230/60/3	Not Available				15P501B01							
	Transformer 460/60/3	Not Available				15P505B01							
	Transformer 575/60/3	Not Available				Not available			15P506B01				
	3 Pole Power Block	Not Available				12P503-06							
2 Pole Screw Term. Block	Not Available					12P500A01							
Sensors & Safeties	Freeze Protection Thermistor	12P505B01				12P505B03							
	HWL Thermistor	Not Available			12P505B02								
	High Pressure Switch	Not Available					35P506B02						
	Low Pressure Switch	Not Available					35P506B01						

NOTE: Part numbers subject to change.

12/14/12

Service Parts cont.

Part Description		Single Speed Horizontal Units													
		009	012	015	018	024	030	036	042	048	060	070			
Compressor	Compressor 208-230/60/1	34P590-01	34P591-01	34P592-01	34P593-01	34P624-01	34P582-01	34P583-01	34P578-01	34P579-01	34P580-01	34P646-01			
	265/60/1	34P590-02	34P591-02	34P592-02	34P593-02	34P624-02	34P582-02	34P583-02	Not Available						
	230/60/3	Not Available				34P624-03	34P582-03	34P583-03	34P578-03	34P579-03	34P580-03	34P646-03			
	460/60/3	Not Available				34P624-04	34P582-04	34P583-04	34P578-04	34P579-04	34P580-04	34P646-04			
	575/60/3	Not Available				Not Available			34P578-05	34P579-05	34P580-05	34P646-05			
	Run Capacitor 208-230/60/1	16P002D17	16P002D18	16P002D19	16P002D19	16P002D19	16P002D20		16P002D21		16P002D25	16P002D24			
	Sound Jacket	92P504A01				92P504A05							92P504A03		
	Power Harness	11P521A01				11P781-01									
Solenoid Harness	Not Available														
VS ECM Motor & Blower	VS ECM Motor 208-230/60/1	Not Available			14S551-01			14S552-01			14S553-01				
	VS ECM Motor 265/60/1	Not Available			14S551-02			14S552-02		Not Available					
	VS ECM Motor 230/60/3	Not Available			14S551-01			14S552-01			14S553-01				
	VS ECM Motor 460/60/3	Not Available				14S551-02			14S552-02			14S553-02			
	VS ECM Blower Housing	Not Available			53P512B01			53P515B01							
	VS ECM Harness	Not Available				11P607B02									
	VS ECM Power Harness	Not Available				11P585B02									
High Static VS ECM Motor & Blower	High Static VS ECM Motor 208-230/60/1	Not Available					14S553-01		14S553-01		Not Available				
	High Static VS ECM Motor 265/60/1	Not Available					14S553-02		Not Available						
	High Static VS ECM Motor 230/60/3	Not Available					14S553-01		14S553-01		Not Available				
	High Static VS ECM Motor 460/60/3	Not Available					14S553-02		14S553-02		Not Available				
5-Speed ECM Motor & Blower	5-Spd ECM Motor 208-230/60/1	Not Available			14P536-01			14P537-01							
	5-Spd ECM Motor 265/60/1	Not Available			14P536-02			14P537-02							
	5-Spd ECM Motor 230/60/3	Not Available			14P536-01			14P537-01							
	5-Spd ECM Motor 460/60/3	Not Available			14P536-03			14P537-03							
	5-Spd ECM Blower Housing	Not Available			53P512B01			53P515B01							
PSC Motor & Blower	PSC Motor 208-230/60/1	14P506-02		14P507B01		14P508B01		14P509B01		14P510B01		14P511B01		14P514B01	
	PSC Motor 265/60/1	14P506-02		14P507B02		14P508B02		14P509B02		14P510B02		Not Available			
	PSC Motor 230/60/3	Not Available			14P508B01			14P509B01		14P510B01		14P511B01		14P514B01	
	PSC Motor 460/60/3	Not Available			14P508B03			14P509B03		14P510B03		14P511B02		14P514B02	
	PSC Motor 575/60/3	Not Available					14P511B03		14P511B03		14P514B03				
	PSC Blower & Housing	53P502B01			53P512B01			53P517-02		53P515B01					
Refrigeration Components	Air Coil	61P600-11	61P601-11	61P608-11		61P609-11	61P610-11	61P611-11	61P612-11		61P613-11				
	Coax	62P586-01	62P572-01	62P585-01		62P566-01	62P573-01	62P574-01		62P543-04		62P555-01			
	TXV	33P605-08	33P608-13	33P608-02	33P608-02	33P619-02			33P619-03		33P619-04	33P619-05			
	Reversing Valve	33P502-05				33P506-04			33P503-05			33P526-05			
	Filter Drier	36P500B01				36P500B01			36P500B02						
HWG	Hot Water Generator	Not Available													
Controls	Contactors	13P004A03													
	Transformer 208-230/60/1	15P501B01					15P501B01								
	Transformer 265/60/1	15P507B01					Not Available								
	Transformer 230/60/3	Not Available				15P501B01									
	Transformer 460/60/3	Not Available				15P505B01									
	Transformer 575/60/3	Not Available				Not available			15P506B01						
	3 Pole Power Block	Not Available				12P503-06									
2 Pole Screw Term. Block	12P500A01					12P505B03									
Sensors & Safeties	Freeze Protection Thermistor	12P505B01				12P505B02									
	HWL Thermistor	Not Available				12P505B02									
	High Pressure Switch	35P506B02					35P506B01								
	Low Pressure Switch	35P506B01					35P506B01								

NOTE: Part numbers subject to change.

12/14/12

Service Parts cont.

Part Description		Dual Capacity Vertical Units					Dual Capacity Horizontal Units						
		026	038	049	064	072	026	038	049	064	072		
Compressor	Compressor 208-230/60/1	34P640-01	34P641-01	34P642-01	34P643-01	34P644-01	34P640-01	34P641-01	34P642-01	34P643-01	34P644-01		
	265/60/1	34P640-02	34P641-02	Not Available			34P640-02	34P641-02	Not Available				
	230/60/3	34P640-03	34P573-03	34P642-03	34P643-03	34P644-03	34P640-03	34P573-03	34P642-03	34P643-03	34P644-03		
	460/60/3	34P640-04	34P573-04	34P642-04	34P575-04	34P644-04	34P640-04	34P573-04	34P642-04	34P575-04	34P644-04		
	575/60/3	Not Available			34P642-05	34P575-05	34P644-05	Not available			34P642-05	34P575-05	34P644-05
	Run Capacitor 208-230/60/1	16P002D19	16P002D20	16P002D18	16P002D39		16P002D19	16P002D20	16P002D18	16P002D39			
	Sound Jacket	92P504A16				92P504A03		92P504A16				92P504A03	
	Power Harness	11P781-01					11P781-01						
Solenoid Harness	11P782-01					11P782-01							
VS ECM Motor & Blower	VS ECM Motor 208-230/60/1	14S551-01	14S552-01		14S553-01		14S551-01	14S552-01		14S553-01			
	VS ECM Motor 265/60/1	14S551-02	14S552-02	Not Available			14S551-02	14S552-02	Not Available				
	VS ECM Motor 230/60/3	14S551-01	14S552-01		14S553-01		14S551-01	14S552-01		14S553-01			
	VS ECM Motor 460/60/3	14S551-02	14S552-02		14S553-02		14S551-02	14S552-02		14S553-02			
	VS ECM Blower Housing	53P512B01	53P515B01				53P512B01	53P515B01					
	VS ECM Harness	11P607B02					11P607B02						
VS ECM Power Harness	11P585B02					11P585B02							
High Static VS ECM Motor & Blower	High Static VS ECM Motor 208-230/60/1	Not Available	14S553-01	14S553-01	Not Available		Not Available	14S553-01	14S553-01	Not Available			
	High Static VS ECM Motor 265/60/1	Not Available	14S553-02	Not Available			Not Available	14S553-02	Not Available				
	High Static VS ECM Motor 230/60/3	Not Available	14S553-01	14S553-01	Not Available		Not Available	14S553-01	14S553-01	Not Available			
	High Static VS ECM Motor 460/60/3	Not Available	14S553-02	14S553-02	Not Available		Not Available	14S553-02	14S553-02	Not Available			
5-Speed ECM Motor & Blower	5-Spd ECM Motor 208-230/60/1	14P536-01		14P537-01			14P536-01		14P537-01				
	5-Spd ECM Motor 265/60/1	14P536-02		14P537-02			14P536-02		14P537-02				
	5-Spd ECM Motor 230/60/3	14P536-01		14P537-01			14P536-01		14P537-01				
	5-Spd ECM Motor 460/60/3	14P536-03		14P537-03			14P536-03		14P537-03				
	5-Spd ECM Blower Housing	53P512B01		53P515B01			53P512B01		53P515B01				
PSC Motor & Blower	PSC Motor 208-230/60/1	Not Available				Not Available							
	PSC Motor 265/60/1	Not Available				Not Available							
	PSC Motor 230/60/3	Not Available				Not Available							
	PSC Motor 460/60/3	Not Available				Not Available							
	PSC Motor 575/60/3	Not Available				Not Available							
	PSC Blower & Housing	Not Available				Not Available							
Refrigeration Components	Air Coil	61P603-11	61S605-11	61S606-11	61P701-11		61P609-11	61611-11	61P612-11	61P649-11			
	Coax	62P566-01	62P574-01	62P543-04	62P543-04	62P557-01	62P566-01	62P574-01	62P543-04		62P555-01		
	TXV	33P619-01	33P619-02	33P619-03	33P619-04	33P619-05	33P619-01	33P619-02	33P619-03	33P619-04	33P619-05		
	Reversing Valve	33P506-04	33P503-05		33P526-04		33P506-04	33P503-05		33P526-04			
	Filter Drier	36P500B01			36P500B02		36P500B01			36P500B02			
HWG	Hot Water Generator	62P516-05		62P516-03			Not Available						
	Contactor	13P004A03			13P004A03								
Controls	Transformer 208-230/60/1	15P501B01			15P501B01								
	Transformer 265/60/1	Not Available			Not Available								
	Transformer 230/60/3	15P501B01			15P501B01								
	Transformer 460/60/3	15P505B01			15P505B01								
	Transformer 575/60/3	Not Available			Not Available								
	3 Pole Power Block	12P503-06			12P503-06								
	2 Pole Screw Term. Block	12P500A01			12P500A01								
Sensors & Safeties	Freeze Protection Thermistor	12P505B03			12P505B03								
	HWL Thermistor	12P505B02			12P505B02								
	High Pressure Switch	35P506B02			35P506B02								
	Low Pressure Switch	35P506B01			35P506B01								

NOTE: Part numbers subject to change.

12/14&/12

Notes

Revision Guide

Pages:	Description:	Date:	By:
All	First Published	08 Apr 2013	DS



Product: **Aston Compact Series**
Type: Geothermal/Water Source Heat Pump
Size: 0.75-6 Ton Single Speed
2-6 Ton Dual Capacity

Document Type: Installation Manual
Part Number: IM1022AG
Release Date: 04/13