

Pneumatic Division

Richland, Michigan USA

www.parker.com/pneumatics



ROTARY DISK VALVE

| Bulletin Number | | Bulletin Description | |
|--------------------------|---------------|--|--|
| <input type="checkbox"/> | V201GP Rev. 8 | PL & VL, 3-Position Installation & Service Instructions | |
| <input type="checkbox"/> | V325P Rev. 3 | HV 4200 & 4400, 3-Position Installation & Service Instructions | |
| <input type="checkbox"/> | Safety Guide | PDN Safety Guide | |



Pneumatic Division
Richland, Michigan 49083

Installation & Service Instructions
V201GP
Rotary Disk 3-Position Valves
(PL & VL)
ISSUED: January, 2007
Supersedes: September, 2000
Doc. #V201GP, EN #070044, Rev. 8

⚠ WARNING

To avoid unpredictable system behavior that can cause personal injury and property damage:

- Disconnect electrical supply (when necessary) before installation, servicing, or conversion.
- Disconnect air supply and depressurize all air lines connected to this product before installation, servicing, or conversion.
- Operate within the manufacturer's specified pressure, temperature, and other conditions listed in these instructions.
- Medium must be moisture-free if ambient temperature is below freezing.
- Service according to procedures listed in these instructions.
- Installation, service, and conversion of these products must be performed by knowledgeable personnel who understand how pneumatic products are to be applied.
- After installation, servicing, or conversion, air and electrical supplies (when necessary) should be connected and the product tested for proper function and leakage. If audible leakage is present, or the product does not operate properly, do not put into use.
- Warnings and specifications on the product should not be covered by paint, etc. If masking is not possible, contact your local representative for replacement labels.

Safety Guide

For more complete information on recommended application guidelines, see the Safety Guide section of Pneumatic Division catalogs or you can download the **Pneumatic Division Safety Guide** at: www.parker.com/safety

Application Limits

These products are intended for use in general purpose compressed air systems only.

Operating Pressure Range:

| | kPa | PSIG | bar |
|---------|-----|------|-----|
| Minimum | 0 | 0 | 0 |

Standard Pressure Rating:

| | | | |
|---------|------|-----|----|
| Maximum | 1000 | 150 | 10 |
|---------|------|-----|----|

High Pressure Rating (PL25HP, PL37HP, PL50HP):

| | | | |
|---------|------|-----|------|
| Maximum | 1723 | 250 | 17.2 |
|---------|------|-----|------|

Operating Temperature Range:

0°F to 160°F (-18°C to 71°C)

Installation & Operating Instructions

As received, the Lever Assembly will need to be assembled to the Valve Body Assembly. Slide the square hole on the Hub onto the Stem and secure it with the Lever Screw (using 40-45 in-lbs torque). Then screw the Ball Knob onto the Lever.

Valve should be installed with reasonable accessibility for service whenever possible - repair service parts are available. Keep pipe or tubing lengths to a minimum with inside clean and free of dirt and chips. Pipe joint compound should be used sparingly and applied only to the male pipe - never into the female port. Do not use PTFE tape to seal pipe joints - pieces have a tendency to break off and lodge inside the unit, possibly causing malfunction.

Filtered and lubricated air is necessary for maximum valve life and minimum maintenance.

Avoid excessive force on the handle. Excessive force can cause internal valve damage.

Factory Pre-Lubrication - All valves are pre-lubricated at assembly with an SAE 85W/140 lubricant, (e.g. Shell Spirax HD-85140 multi-purpose oil & gear lubricant).

⚠ CAUTION: This valve shall NOT be used to actuate a punch press. Do NOT use this valve on punch presses or press brakes. See OSHA 1910.219.

Valve Operation

Closed Center Valves (PL)

| Position | Cyl. A | Cyl. B |
|----------|----------|----------|
| CW | pressure | exhaust |
| Neutral | closed | closed |
| CCW | exhaust | pressure |

Position Definition - All ports are blocked in neutral position.

Closed center valves have a 90 degree lever movement. In neutral position, inlet is closed to pressure & outlets are closed to exhaust. This valve is recommended for stationary air cylinders, and as a throttling valve for positioning air cylinders.

Open Center Valves (VL)

| Position | Cyl. A | Cyl. B |
|----------|----------|----------|
| CW | pressure | exhaust |
| Neutral | exhaust | exhaust |
| CCW | exhaust | pressure |

Position Definition - Cylinder ports are open to exhaust & inlet is blocked in neutral position.

Open center valves also have a 90 degree lever movement. In neutral position, inlet is closed to pressure & outlets are open to exhaust. This valve is particularly suited for pneumatic chuck operation.

Port Identifications / Connections

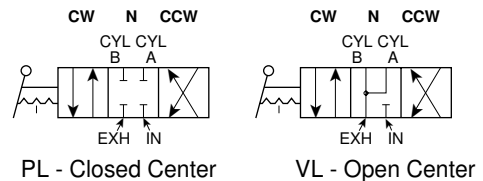

⚠ WARNING

FAILURE OR IMPROPER SELECTION OR IMPROPER USE OF THE PRODUCTS AND/OR SYSTEMS DESCRIBED HEREIN OR RELATED ITEMS CAN CAUSE DEATH, PERSONAL INJURY AND PROPERTY DAMAGE.

This document and other information from Parker Hannifin Corporation, its subsidiaries and authorized distributors provide product and/or system options for further investigation by users having technical expertise. It is important that you analyze all aspects of your application, including consequences of any failure and review the information concerning the product or systems in the current product catalog. Due to the variety of operating conditions and applications for these products or systems, the user, through its own analysis and testing, is solely responsible for making the final selection of the products and systems and assuring that all performance, safety and warning requirements of the application are met.

The products described herein, including without limitation, product features, specifications, designs, availability and pricing, are subject to change by Parker Hannifin Corporation and its subsidiaries at any time without notice.

EXTRA COPIES OF THESE INSTRUCTIONS ARE AVAILABLE FOR INCLUSION IN EQUIPMENT / MAINTENANCE MANUALS THAT UTILIZE THESE PRODUCTS. CONTACT YOUR LOCAL REPRESENTATIVE.

Service Procedures

To dis-assemble unit, use the following procedure:

Remove the lever assembly by unscrewing the lever screw and then lifting the lever's hub off of the stem. Remove the 8 socket head cap screws using an Allen wrench to detach the head from the valve body assembly. (The 1/4 & 3/8 NPT port valves require a 5/32" wrench, and the 1/2 NPT port valves require a 1/4" wrench.)

Note: These two parts will only bolt together one way but their proper orientation can be difficult to decipher quickly. Re-assembly will be easier and quicker if you draw a white line across their edges before separating them.

Note the orientation of the brass disk. For both the "P" & "V" type, the through hole is positioned above the detent boss. The two types of disks look quite similar; they are distinguished by a "P" or "V" in their flow chambers.

These valves can be converted from detent to non-detent operation by removing the steel ball and detent spring. Since the head and disk are lap finished to form an air tight seal, they need to be kept as a matched pair.

The assembly procedure is the reverse of how the unit was dis-assembled. If the valve is dirty inside, clean the valve thoroughly by wiping the dirty oil from the parts. Inspect for possible nicks, scratches, and material imperfections. Then dip the lap surface of the brass disk in a multi-purpose oil & gear lubricant before assembling it to the stem and head. Replace the body gasket with a new one.

For the valves with 1/4" & 3/8" ports, apply 40-45 in-lbs of torque to the socket head cap screws; and apply 120-130 in-lbs for those with 1/2" ports. Secure the lever assembly to the valve body assembly using 40-45 in-lbs torque.

If you have questions concerning how to service this unit, contact your local authorized dealer or your customer service representative.

Maintenance & Trouble Shooting Hints:

Air Leakage Through Exhaust Ports:

1. Check for internal leakage in cylinder being operated by the valve.
2. Check for loose socket head cap screws.
3. Check for broken disk spring, & lapped surfaces of brass disk and head for nicks, scratches, and dirt particles.

See Service Procedures for repair instructions.

Service Kit and Parts Available

Lever Assembly Service Kits:

(consists of items # 12, 13, & 14)

| | |
|--|----------|
| PL25, PL25HP, PL37, PL37HP, VL25, & VL37..... | PL2425BP |
| PL50, PL50HP & VL50 | PL2424BP |

Body Gasket:

| | |
|--|--------|
| PL25, PL25HP, PL37, PL37HP, VL25, & VL37..... | P66837 |
| PL50, PL50HP & VL50 | P66829 |

Part Identification List

| Item # | Description |
|--------|----------------------------------|
| 1 | Valve Body Assembly |
| 2 | Valve Body |
| 3 | Disk Spring |
| 4 | Disk |
| 5 | Stem |
| 6 | Body Gasket |
| 7 | Head |
| 8 | Socket Head Cap Screw |
| 9 | Steel Ball |
| 10 | Detent Spring |
| 11 | Lever Assembly |
| 12 | Hub & Lever Bar |
| 13 | Ball Knob |
| 14 | Lever Screw (Phillips Oval Head) |

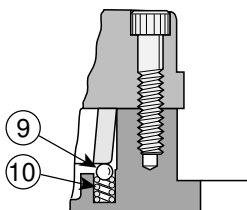
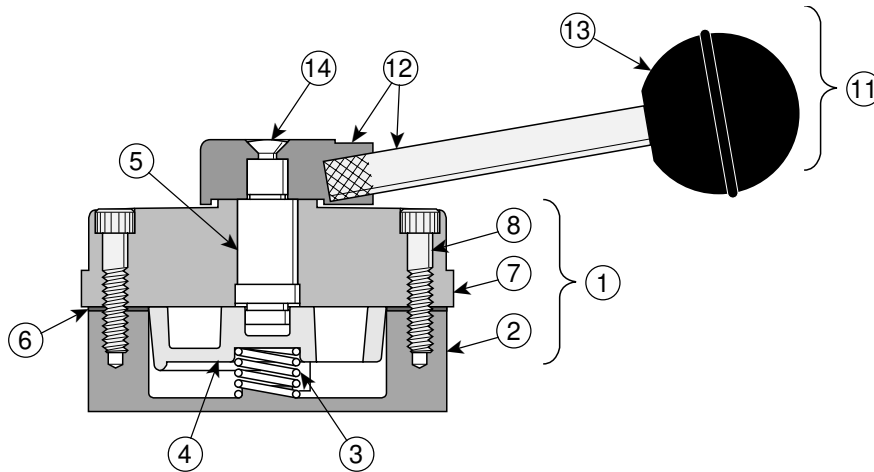



Pneumatic Division
 Richland, Michigan 49083

Installation & Service Instructions
V325P

Rotary Disk 3-Position Valves
 (HV 4200 and 4400)

ISSUED: November, 2004
Supersedes: July, 2001

Doc.# V-325P, ECN# 041069, Rev. 3

⚠ WARNING

To avoid unpredictable system behavior that can cause personal injury and property damage:

- Disconnect electrical supply (when necessary) before installation, servicing, or conversion.
- Disconnect air supply and depressurize all air lines connected to this product before installation, servicing, or conversion.
- Operate within the manufacturer's specified pressure, temperature, and other conditions listed in these instructions.
- Medium must be moisture-free if ambient temperature is below freezing.
- Service according to procedures listed in these instructions.
- Installation, service, and conversion of these products must be performed by knowledgeable personnel who understand how pneumatic products are to be applied.
- After installation, servicing, or conversion, air and electrical supplies (when necessary) should be connected and the product tested for proper function and leakage. If audible leakage is present, or the product does not operate properly, do not put into use.
- Warnings and specifications on the product should not be covered by paint, etc. If masking is not possible, contact your local representative for replacement labels.

Introduction

Follow these instructions when installing, operating, or servicing the product.

Application Limits

These products are intended for use in general purpose compressed air systems only.

Operating Pressure Range

| | psig | bar | kPa |
|---------|------|-----|------|
| Minimum | 0 | 0 | 0 |
| Maximum | 150 | 10 | 1000 |

Operating Temperature Range

23°F to 140°F (-5°C to 60°C)

Installation and Operating Instructions

As received, the Lever Bar Assembly will need to be assembled to the Hub on top of the Valve Body Assembly (using 40-45 in-lb torque). Valve should be installed with reasonable accessibility for service whenever possible - repair service parts are available. Keep pipe or tubing lengths to a minimum with inside clean and free of dirt and chips. Pipe joint compound should be used sparingly and applied only to the male pipe - never into the female port. Do not use PTFE tape to seal pipe joints - pieces have a tendency to break off and lodge inside the unit, possibly causing malfunction.

Filtered and lubricated air is necessary for maximum valve life and minimum maintenance.

Avoid excessive force on the Lever. Excessive force can cause internal valve damage.

Parker F442 oil is recommended for lubrication. This oil is specially formulated to provide peak performance and maximum service life from all air operated equipment. Alternative compatible lubricants

should be of a paraffin based mineral oil having 150 to 200 SUS viscosity @100°F and an aniline point greater than 200°F. (Mobil DTE24 and Sun Company Sunvis 932 are good examples.)

Factory Pre-Lubrication - All valves are pre-lubricated at assembly with an Lithium based grease, (e.g. Deluxe Grease, 621G).

⚠ CAUTION: This valve shall NOT be used to actuate a punch press. Do NOT use this valve on punch presses or press brakes. See OSHA 1910.219.

⚠ CAUTION: Connect supply air to "IN" port only. Supply air connected to any other port can cause internal damage.

Valve Operation

Closed Center Valves

| Position | Port C1 | Port C2 |
|----------|----------|----------|
| CW | exhaust | pressure |
| Neutral | closed | closed |
| CCW | pressure | exhaust |

Position Definition - All ports are blocked in neutral position.

Closed center valves have a 90 degree lever movement. In neutral position, inlet is closed to pressure and outlets are closed to exhaust. This valve is recommended for stationary air cylinders, and as a throttling valve for positioning air cylinders.

Port Identifications / Connections

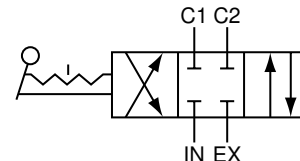

⚠ WARNING

FAILURE OR IMPROPER SELECTION OR IMPROPER USE OF THE PRODUCTS AND/OR SYSTEMS DESCRIBED HEREIN OR RELATED ITEMS CAN CAUSE DEATH, PERSONAL INJURY AND PROPERTY DAMAGE.

This document and other information from Parker Hannifin Corporation, its subsidiaries and authorized distributors provide product and/or system options for further investigation by users having technical expertise. It is important that you analyze all aspects of your application, including consequences of any failure and review the information concerning the product or systems in the current product catalog. Due to the variety of operating conditions and applications for these products or systems, the user, through its own analysis and testing, is solely responsible for making the final selection of the products and systems and assuring that all performance, safety and warning requirements of the application are met.

The products described herein, including without limitation, product features, specifications, designs, availability and pricing, are subject to change by Parker Hannifin Corporation and its subsidiaries at any time without notice.

EXTRA COPIES OF THESE INSTRUCTIONS ARE AVAILABLE FOR INCLUSION IN EQUIPMENT / MAINTENANCE MANUALS THAT UTILIZE THESE PRODUCTS. CONTACT YOUR LOCAL REPRESENTATIVE.

Service Procedures

To disassemble unit, use the following procedure:

Remove the Hub by unscrewing the Lever Screw (using Screw Driver for HV4400 series and Allen wrench (2.5mm) for HV4200 Series) and lifting the Hub off of the Stem. Remove the four (4) Socket Head Cap Screws using an Allen wrench (4mm wrench) to detach the Cap from the Valve Body Assembly.

Note: These two parts will only bolt together one way, but their proper orientation can be difficult to decipher quickly. Reassembly will be easier and quicker if you draw a white line across their edges before separating them.

The assembly procedure is the reverse of how the unit was disassembled. If the Valve is dirty inside, clean the Valve thoroughly by wiping the dirty oil from the parts. Inspect for possible nicks, scratches, and material imperfections. Then apply lubricants, such as a Lithium based grease or other compatible ones, on the lapped surface of the Disk or other moving contacts at assembly. Replace the Body Gasket with a new one.

For the Valves with 1/2" and 3/8" and 1/4" ports, apply 40-45 in-lb of torque to the Socket Head Cap Screws. Secure the Lever Assembly to the Valve Body Assembly using 40-45 in-lb of torque.

If you have questions concerning how to service this unit, contact your local authorized dealer or your customer service representative.

Maintenance and Trouble Shooting Hints

Air Leakage Through Exhaust Ports:

1. Check for internal leakage in cylinder being operated by the valve.
2. Check for loose socket head cap screw.
3. Check for broken disk spring and lapped surfaces of disk and seals for nicks, scratches, and dirt particles.

See Service Procedures for repair instructions.

Service Kit and Parts Available

Disk and Seal Service Kits

(consists of Item Numbers 3, 4, 6, 10, 12)

| | |
|---------------|------------|
| HV 4200 | HVRK420001 |
| HV 4400 | HVRK440001 |

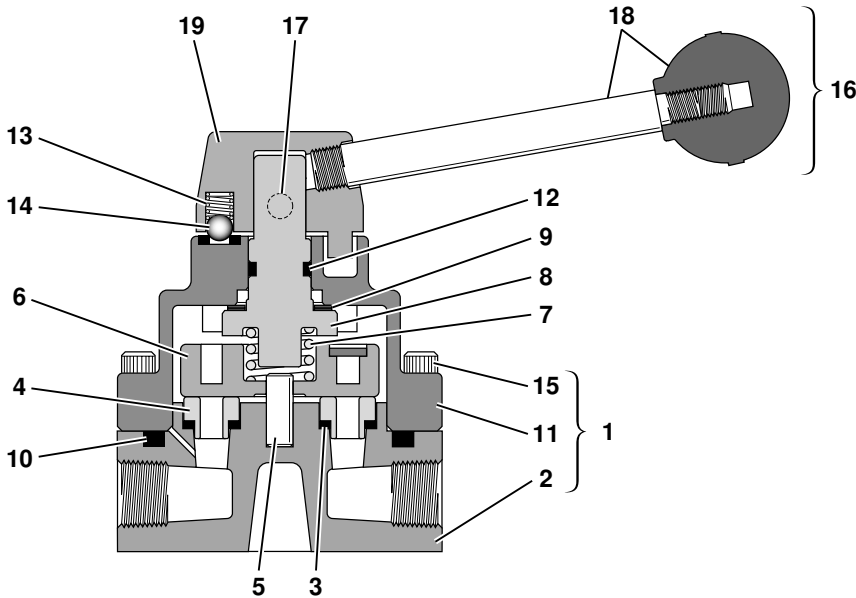

Part Identification List

| Item Number | Description |
|-------------|-----------------------|
| 1 | Valve Body Assembly |
| 2 | Valve Body |
| 3 | Seal O-Ring |
| 4 | Seal |
| 5 | Center Bar |
| 6 | Disk |
| 7 | Disk Spring |
| 8 | Stem |
| 9 | Stem Washer |
| 10 | Body Gasket |
| 11 | Cap |
| 12 | Stem O-Ring |
| 13 | Detent Spring |
| 14 | Steel Ball |
| 15 | Socket Head Cap Screw |
| 16 | Lever Assembly |
| 17 | Lever Screw |
| 18 | Lever Bar Assembly |
| 19 | Hub |



Pneumatic Division
Richland, Michigan 49083
269-629-5000

PDNSG-1

Pneumatic Division Safety Guide

ISSUED: August 1, 2006

Supersedes: June 1, 2006

Safety Guide For Selecting And Using Pneumatic Division Products And Related Accessories

WARNING:

FAILURE OR IMPROPER SELECTION OR IMPROPER USE OF PNEUMATIC DIVISION PRODUCTS, ASSEMBLIES OR RELATED ITEMS ("PRODUCTS") CAN CAUSE DEATH, PERSONAL INJURY, AND PROPERTY DAMAGE. POSSIBLE CONSEQUENCES OF FAILURE OR IMPROPER SELECTION OR IMPROPER USE OF THESE PRODUCTS INCLUDE BUT ARE NOT LIMITED TO:

- Unintended or mistimed cycling or motion of machine members or failure to cycle
- Work pieces or component parts being thrown off at high speeds.
- Failure of a device to function properly for example, failure to clamp or unclamp an associated item or device.
- Explosion
- Suddenly moving or falling objects.
- Release of toxic or otherwise injurious liquids or gasses.

Before selecting or using any of these Products, it is important that you read and follow the instructions below.

1. GENERAL INSTRUCTIONS

- 1.1. Scope:** This safety guide is designed to cover general guidelines on the installation, use, and maintenance of Pneumatic Division Valves, FRLs (Filters, Pressure Regulators, and Lubricators), Vacuum products and related accessory components.
- 1.2. Fail-Safe:** Valves, FRLs, Vacuum products and their related components can and do fail without warning for many reasons. Design all systems and equipment in a fail-safe mode, so that failure of associated valves, FRLs or Vacuum products will not endanger persons or property.
- 1.3. Relevant International Standards:** For a good guide to the application of a broad spectrum of pneumatic fluid power devices see: ISO 4414:1998, Pneumatic Fluid Power – General Rules Relating to Systems. See www.iso.org for ordering information.
- 1.4. Distribution:** Provide a copy of this safety guide to each person that is responsible for selection, installation, or use of Valves, FRLs or Vacuum products. Do not select, or use Parker valves, FRLs or vacuum products without thoroughly reading and understanding this safety guide as well as the specific Parker publications for the products considered or selected.
- 1.5. User Responsibility:** Due to the wide variety of operating conditions and applications for valves, FRLs, and vacuum products Parker and its distributors do not represent or warrant that any particular valve, FRL or vacuum product is suitable for any specific end use system. This safety guide does not analyze all technical parameters that must be considered in selecting a product. The user, through its own analysis and testing, is solely responsible for:
 - Making the final selection of the appropriate valve, FRL, Vacuum component, or accessory.
 - Assuring that all user's performance, endurance, maintenance, safety, and warning requirements are met and that the application presents no health or safety hazards.
 - Complying with all existing warning labels and / or providing all appropriate health and safety warnings on the equipment on which the valves, FRLs or Vacuum products are used; and,
 - Assuring compliance with all applicable government and industry standards.
- 1.6. Safety Devices:** Safety devices should not be removed, or defeated.
- 1.7. Warning Labels:** Warning labels should not be removed, painted over or otherwise obscured.
- 1.8. Additional Questions:** Call the appropriate Parker technical service department if you have any questions or require any additional information. See the Parker publication for the product being considered or used, or call 1-800-CPARKER, or go to www.parker.com, for telephone numbers of the appropriate technical service department.

2. PRODUCT SELECTION INSTRUCTIONS

- 2.1. Flow Rate:** The flow rate requirements of a system are frequently the primary consideration when designing any pneumatic system. System components need to be able to provide adequate flow and pressure for the desired application.
- 2.2. Pressure Rating:** Never exceed the rated pressure of a product. Consult product labeling, Pneumatic Division catalogs or the instruction sheets supplied for maximum pressure ratings.
- 2.3. Temperature Rating:** Never exceed the temperature rating of a product. Excessive heat can shorten the life expectancy of a product and result in complete product failure.
- 2.4. Environment:** Many environmental conditions can affect the integrity and suitability of a product for a given application. Pneumatic Division products are designed for use in general purpose industrial applications. If these products are to be used in unusual circumstances such as direct sunlight and/or corrosive or caustic environments, such use can shorten the useful life and lead to premature failure of a product.
- 2.5. Lubrication and Compressor Carryover:** Some modern synthetic oils can and will attack nitrile seals. If there is any possibility of synthetic oils or greases migrating into the pneumatic components check for compatibility with the seal materials used. Consult the factory or product literature for materials of construction.
- 2.6. Polycarbonate Bowls and Sight Glasses:** To avoid potential polycarbonate bowl failures:
 - Do not locate polycarbonate bowls or sight glasses in areas where they could be subject to direct sunlight, impact blow, or temperatures outside of the rated range.
 - Do not expose or clean polycarbonate bowls with detergents, chlorinated hydro-carbons, ketones, esters or certain alcohols.
 - Do not use polycarbonate bowls or sight glasses in air systems where compressors are lubricated with fire resistant fluids such as phosphate ester and di-ester lubricants.

Pneumatic Division Safety Guide

2.7. Chemical Compatibility: For more information on plastic component chemical compatibility see Pneumatic Division technical bulletins Tec-3, Tec-4, and Tec-5

- 2.8. Product Rupture:** Product rupture can cause death, serious personal injury, and property damage.
- Do not connect pressure regulators or other Pneumatic Division products to bottled gas cylinders.
 - Do not exceed the maximum primary pressure rating of any pressure regulator or any system component.
 - Consult product labeling or product literature for pressure rating limitations.

3. PRODUCT ASSEMBLY AND INSTALLATION INSTRUCTIONS

- 3.1. Component Inspection:** Prior to assembly or installation a careful examination of the valves, FRLs or vacuum products must be performed. All components must be checked for correct style, size, and catalog number. DO NOT use any component that displays any signs of nonconformance.
- 3.2. Installation Instructions:** Parker published Installation Instructions must be followed for installation of Parker valves, FRLs and vacuum components. These instructions are provided with every Parker valve or FRL sold, or by calling 1-800-CPARKER, or at www.parker.com.
- 3.3. Air Supply:** The air supply or control medium supplied to Valves, FRLs and Vacuum components must be moisture-free if ambient temperature can drop below freezing

4. VALVE AND FRL MAINTENANCE AND REPLACEMENT INSTRUCTIONS

- 4.1. Maintenance:** Even with proper selection and installation, valve, FRL and vacuum products service life may be significantly reduced without a continuing maintenance program. The severity of the application, risk potential from a component failure, and experience with any known failures in the application or in similar applications should determine the frequency of inspections and the servicing or replacement of Pneumatic Division products so that products are replaced before any failure occurs. A maintenance program must be established and followed by the user and, at minimum, must include instructions 4.2 through 4.10.
- 4.2. Installation and Service Instructions:** Before attempting to service or replace any worn or damaged parts consult the appropriate Service Bulletin for the valve or FRL in question for the appropriate practices to service the unit in question. These Service and Installation Instructions are provided with every Parker valve and FRL sold, or are available by calling 1-800-CPARKER, or by accessing the Parker web site at www.parker.com.
- 4.3. Lockout / Tagout Procedures:** Be sure to follow all required lockout and tagout procedures when servicing equipment. For more information see: OSHA Standard – 29 CFR, Part 1910.147, Appendix A, The Control of Hazardous Energy – (Lockout / Tagout)
- 4.4. Visual Inspection:** Any of the following conditions requires immediate system shut down and replacement of worn or damaged components:
- Air leakage: Look and listen to see if there are any signs of visual damage to any of the components in the system. Leakage is an indication of worn or damaged components.
 - Damaged or degraded components: Look to see if there are any visible signs of wear or component degradation.
 - Kinked, crushed, or damaged hoses. Kinked hoses can result in restricted air flow and lead to unpredictable system behavior.
 - Any observed improper system or component function: Immediately shut down the system and correct malfunction.
 - Excessive dirt build-up: Dirt and clutter can mask potentially hazardous situations.

Caution: Leak detection solutions should be rinsed off after use.

- 4.5. Routine Maintenance Issues:**
- Remove excessive dirt, grime and clutter from work areas.
 - Make sure all required guards and shields are in place.
- 4.6. Functional Test:** Before initiating automatic operation, operate the system manually to make sure all required functions operate properly and safely.
- 4.7. Service or Replacement Intervals:** It is the user's responsibility to establish appropriate service intervals. Valves, FRLs and vacuum products contain components that age, harden, wear, and otherwise deteriorate over time. Environmental conditions can significantly accelerate this process. Valves, FRLs and vacuum components need to be serviced or replaced on routine intervals. Service intervals need to be established based on:
- Previous performance experiences.
 - Government and / or industrial standards.
 - When failures could result in unacceptable down time, equipment damage or personal injury risk.
- 4.8. Servicing or Replacing of any Worn or Damaged Parts:** To avoid unpredictable system behavior that can cause death, personal injury and property damage:
- Follow all government, state and local safety and servicing practices prior to service including but not limited to all OSHA Lockout Tagout procedures (OSHA Standard – 29 CFR, Part 1910.147, Appendix A, The Control of Hazardous Energy – Lockout / Tagout).
 - Disconnect electrical supply (when necessary) before installation, servicing, or conversion.
 - Disconnect air supply and depressurize all air lines connected to system and Pneumatic Division products before installation, service, or conversion.
 - Installation, servicing, and / or conversion of these products must be performed by knowledgeable personnel who understand how pneumatic products are to be applied.
 - After installation, servicing, or conversions air and electrical supplies (when necessary) should be connected and the product tested for proper function and leakage. If audible leakage is present, or if the product does not operate properly, do not put product or system into use.
 - Warnings and specifications on the product should not be covered or painted over. If masking is not possible, contact your local representative for replacement labels.
- 4.9. Putting Serviced System Back into Operation:** Follow the guidelines above and all relevant Installation and Maintenance Instructions supplied with the valve FRL or vacuum component to insure proper function of the system.