

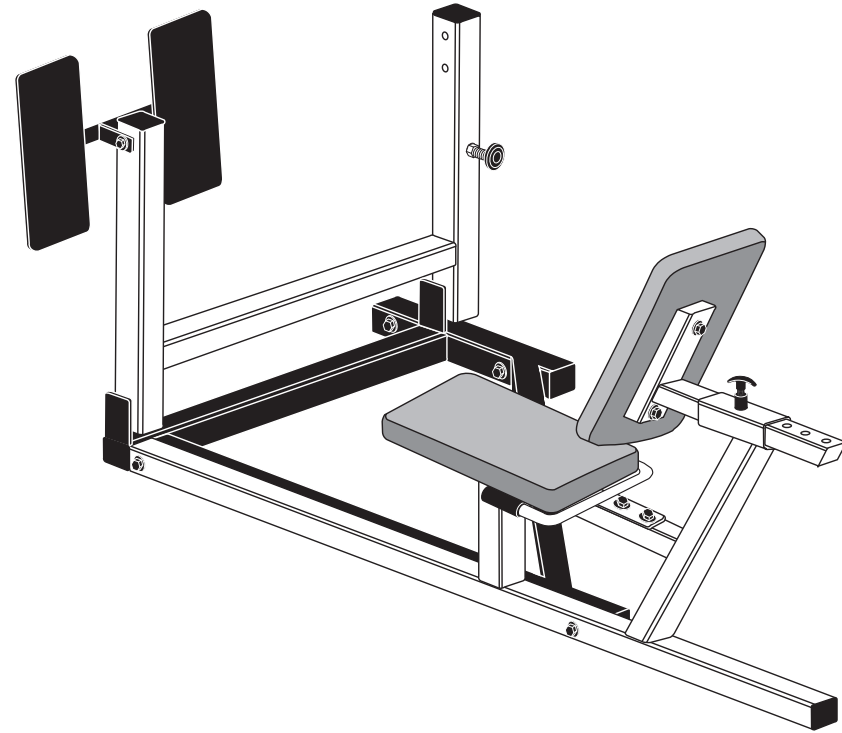

Solana Leg Press Option



Assembly Instructions

Important Safety Instructions

Before beginning any fitness program, you should obtain a complete physical examination from your physician.

Il est conseillé de subir un examen médical complet avant d'entreprendre tout programme d'exercice. Si vous avez des étourdissements ou des faiblesses, arrêtez les exercices immédiatement.

When using exercise equipment, basic precautions should always be taken, including the following:

- Read all instructions before using the Leg Press Option. These instructions are written to ensure your safety and to protect the unit.
- Do not allow children on or near the equipment.
- Use the equipment only for its intended purpose as described in this guide. Do not use accessory attachments that are not recommended by the manufacturer: such attachments might cause injuries.
- Wear proper exercise clothing and shoes for your workout—no loose clothing.
- Use care when getting on or off the unit.
- Do not overexert yourself or work to exhaustion.
- If you feel any pain or abnormal symptoms, stop your workout immediately and consult your physician.

- Never operate the unit after it has been dropped or damaged. Return the equipment to a service center for examination and repair.
- Never drop or insert objects into any opening in the equipment. Keep hands away from moving parts.
- Always check the unit and its cables before using it. Make sure that all fasteners and cables are secure and in good working condition.
- Do not use the equipment outdoors.

Personal Safety During Assembly

- It is strongly recommended that a qualified dealer assemble the equipment. **Assistance is required.**
- Read each step in the assembly instructions and follow the steps in sequence. Do not skip ahead. If you skip ahead, you may learn later that you have to disassemble components and that you may have damaged the equipment.
- Assemble and operate the Leg Press Option on a solid, level surface. Locate the unit a few feet from walls or furniture to provide easy access.

The Leg Press Option is designed for your enjoyment. By following these precautions and using common sense, you will have many safe and pleasurable hours of healthful exercise with your Pacific Fitness strength-training equipment.

Obtaining Service

Do not attempt to service the Leg Press Option yourself. This unit does not contain any user-serviceable parts.

For information about product operation or service, check out the Precor web site at www.precor.com or contact an authorized Precor dealer or a Precor factory-authorized service company. To locate the dealer or service person nearest you, call 1-800-4-PRECOR.

If you call or e-mail Customer Service, have your serial and part numbers available.

The serial number is printed on a label on the side of the Leg Press Option. For future reference, write the serial number below.

Serial number: _____

Table of Contents

	Important Safety Instructions	2
	Personal Safety During Assembly	2
	Obtaining Service	2
1	Before You Begin	4
	Unpacking the Equipment	4
2	Preparations	5
	Required Tools	5
	Installation Requirements	5
	Assembly Tips	5
3	Assembly Instructions	6
	1. Attach the Leg Press to the Solana	7
	2. Attach the Seat Frame to the Leg Press	8
	3. Assemble the Seat Pads	9
	4. Assemble the Pulleys	10
	5. Route the Cable	11
4	Cable Adjustments	12
	1. Press Arm Adjustment	13
	2. Support Arm Adjustment	14
	Warranty Card	Back cover
	Specifications	Back cover

1

Before You Begin

Thank you for purchasing the Leg Press Option for the Solana equipment. This option will add a new dimension to your strength-training regimen. For proper installation, please read this guide thoroughly and follow the assembly instructions.

Unpacking the Equipment

The Leg Press Option is carefully tested and inspected before shipment. The unit is shipped in one box and has several pieces that require assembly. Two people are required to assemble this equipment. Ask for assistance during the assembly process.

- Review the *Installation Requirements* on the next page.
- Carefully unpack the pieces and lay them on the floor near the place where you plan to use the equipment.

If any items are missing, contact the dealer from whom you purchased the unit.

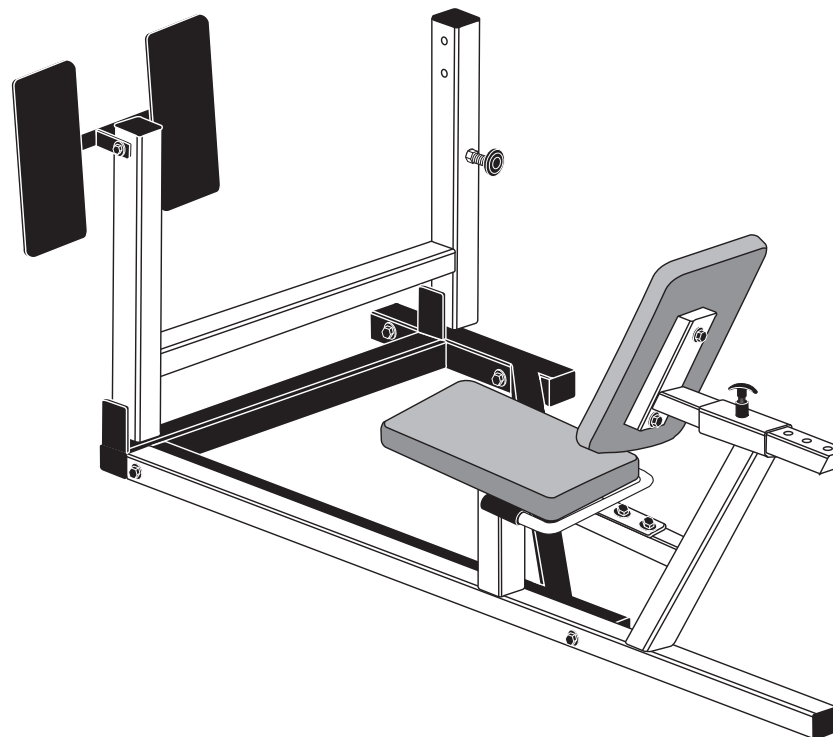

2

Preparations

CAUTION: To set up this equipment, you will need assistance. Do not attempt assembly by yourself.

You must review and follow the instructions in this guide. If you do not assemble and use the Leg Press Option according to the following guidelines, you could void the Precor limited warranty.

Required Tools

You must obtain these tools before assembling the unit:

- 3/4-inch socket wrench
- 3/4-inch box-end wrench
- 9/16-inch socket wrench
- 9/16-inch box-end wrench
- Two adjustable pliers or crescent wrenches
- Standard set of metric Allen wrenches
- Utility knife or scissors
- Measuring tape

Installation Requirements

Follow these installation requirements when assembling the unit:

- **Fill out and mail the limited warranty card.** The warranty card is found on the back cover of this guide.
- **Set up the Leg Press Option on a solid, flat surface.** A smooth, flat surface under the unit helps keep it level. A level unit has fewer malfunctions.
- **Provide ample space around the machine.** Open space around the machine allows for easier access.
- **Insert all bolts in the same direction.** For aesthetic purposes, insert all the bolts in the same direction unless specified (in text or illustrations) to do otherwise.
- **Leave room for adjustments.** Tighten fasteners (such as bolts, nuts, and screws) so that the unit is stable, but leave room for adjustments. Do not fully tighten fasteners until instructed in the assembly steps to do so.

Assembly Tips

- A black, 6-inch scale with white numbers is provided at the bottom of each assembly instruction page. Use this scale to identify the correct size for bolts and spacers. The head of a bolt is not used to measure the length of a bolt.

To find the length of a particular bolt, measure its shank (the long, narrow part beneath the head). Refer to the following diagram.

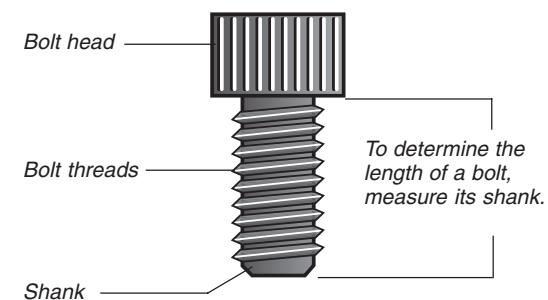

- Read all caution notes on each page before completing that step.
- Some pieces have extra holes that you will not use. Use only those holes indicated in the instructions and illustrations.
- While you may be able to assemble the Leg Press Option by using the illustrations only, refer to the text for important safety cautions and notes.

3

Assembly Instructions

Assembly of the Leg Press Option takes professional installers about 1 hour to complete. If this is the first time you have assembled this type of equipment, plan on significantly more time.

Professional installers are highly recommended.

CAUTION: Obtain assistance! Do not attempt to assemble the Leg Press Option by yourself. Because of the weight and size of the equipment, you could be injured or damage the equipment. Review the *Installation Requirements* on page 5 before proceeding.

Important: For ease of assembly, the fasteners and hardware for each step are labeled and packaged in separate bags. **Assemble the components in the sequence presented in this guide.**

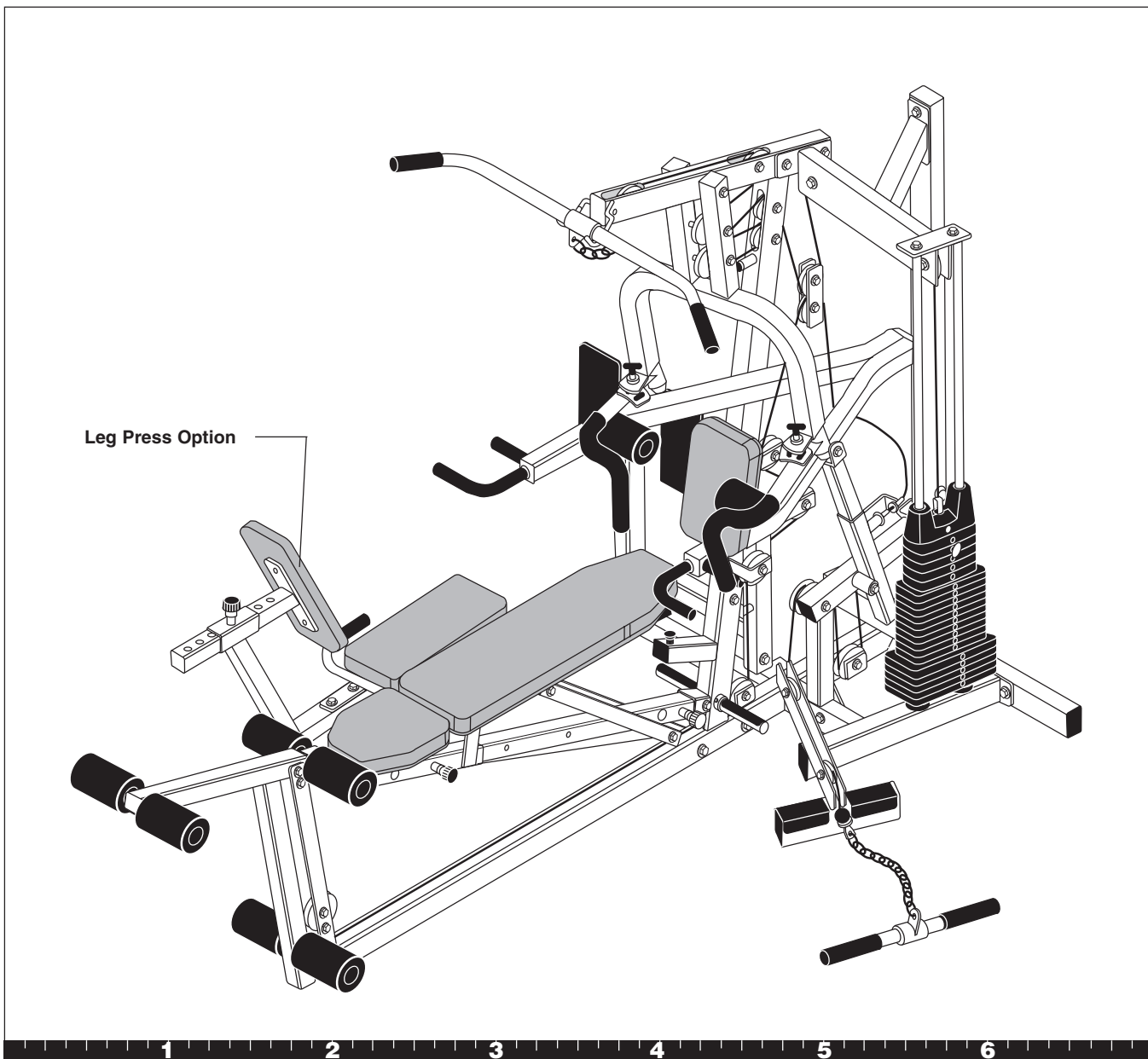

1. Attach the Leg Press to the Solana

- A. The Leg Press Option shares a bolt hole at the base of the Main Base. Remove one 3-inch bolt, two washers, and one locknut.
- B. Attach the Leg Press Base to the Main Base, opposite the weight stack, using two 4¾-inch bolts, four washers, and two locknuts. Alternately wrench tighten both fasteners.
- C. Rest the Support Arm against the Side Upright.

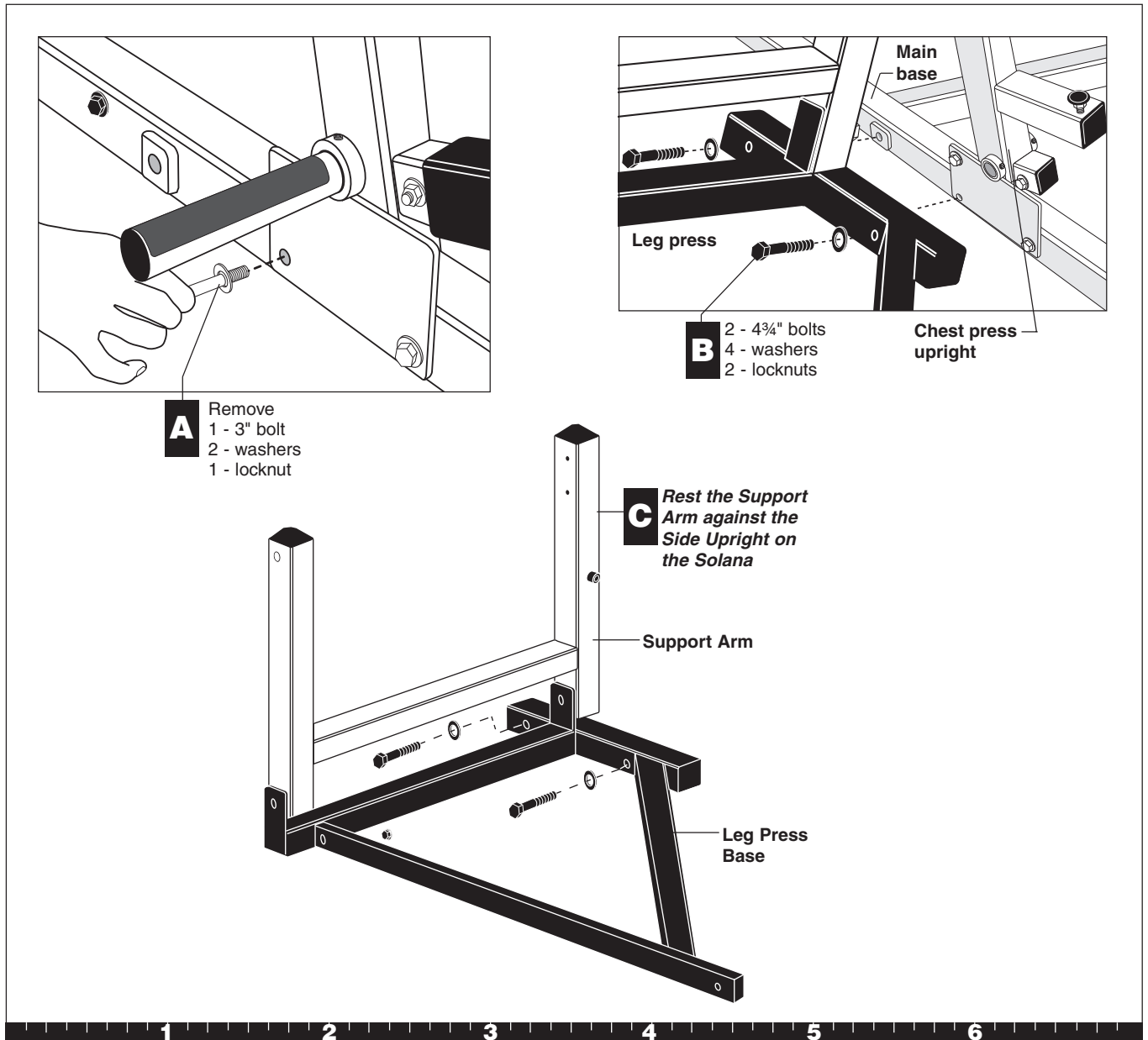

Step 1. Attach the Leg Press to the Solana

2. Attach the Seat Frame to the Leg Press

- A. Attach the Seat Frame to the Leg Press Base using two 3¾-inch bolts four washers two locknuts Wrench tighten.
- B. Remove the Seat Bracket Support from the Seat Frame. The holes in the Seat Bracket Support should face up.
- C. Lift the Pop Pin and slide the Seat Bracket Support back through the Seat Frame. Lower the Pop Pin and make sure that it engages in one of the holes in the bracket.
- D. Attach the Handle to the Seat Frame using two 3-inch bolts four washers two locknuts Wrench tighten.
- E. Attach the Footrest to the Support Arm. Have an assistant stabilize the Support Arm while you attach the Footrest using one large ½-inch diameter by 3½-inch large bolt two large ½-inch washers one large ½-inch self-locking nut Wrench tighten.

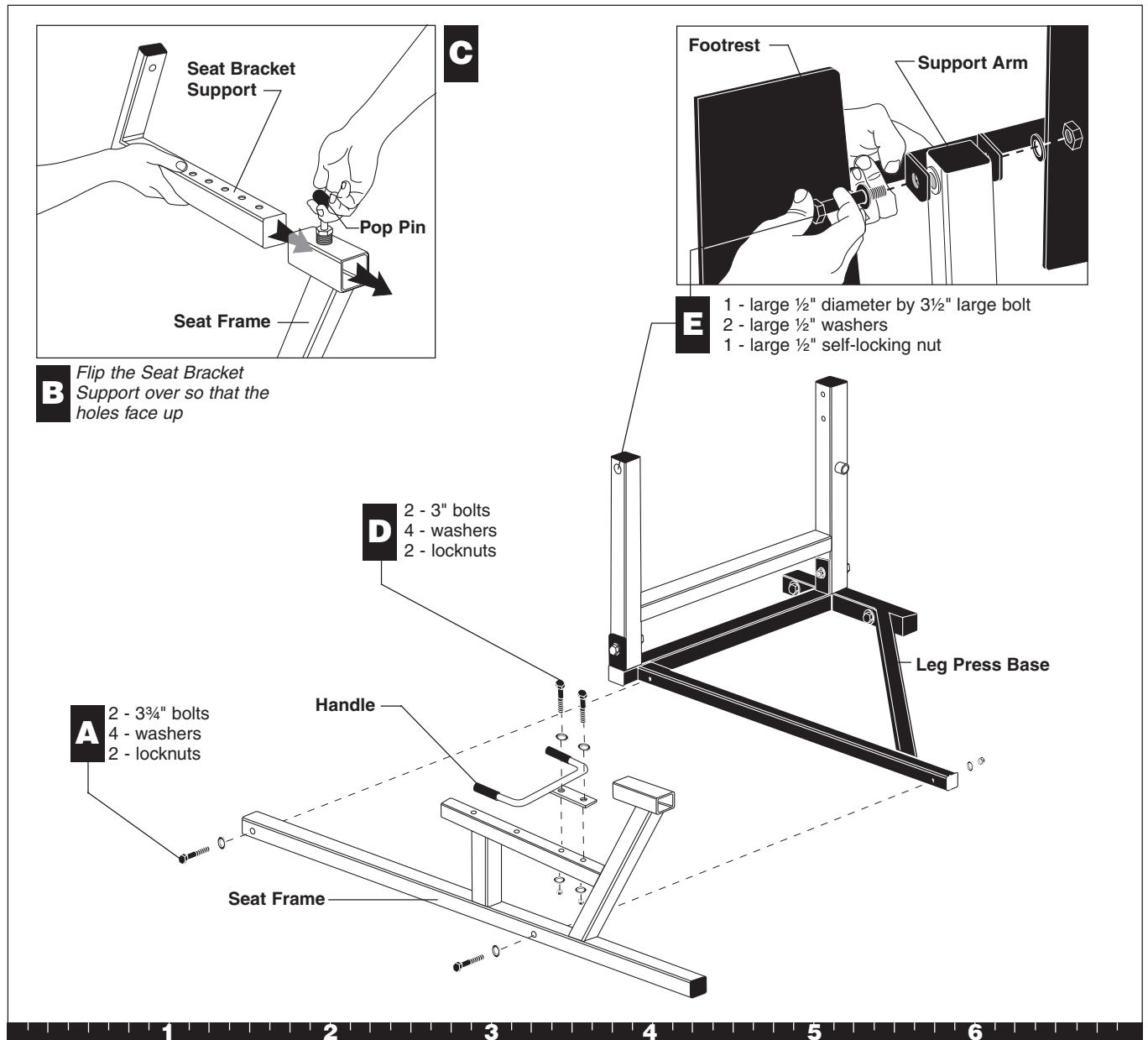

Step 2. Attach the Seat Fram to the Leg Press

3. Assemble the Seat Pads

Note: Make sure that the seams on the Seat Pads face toward the frame.

- A. Determine which Seat Pad you want to use as the Backpad and attach it to the Seat Bracket Support using two 1 $\frac{3}{4}$ -inch bolts two washers Wrench tighten.
- B. Lift the Pop Pin and slide the Backpad out of the way to mount the other Seat Pad.
- C. Attach the Seat Pad to the Seat Frame using two 2 $\frac{3}{4}$ -inch bolts two washers Wrench tighten.
- D. In preparation for assembling the pulleys, lower the Support Arm so that it rests on the floor.

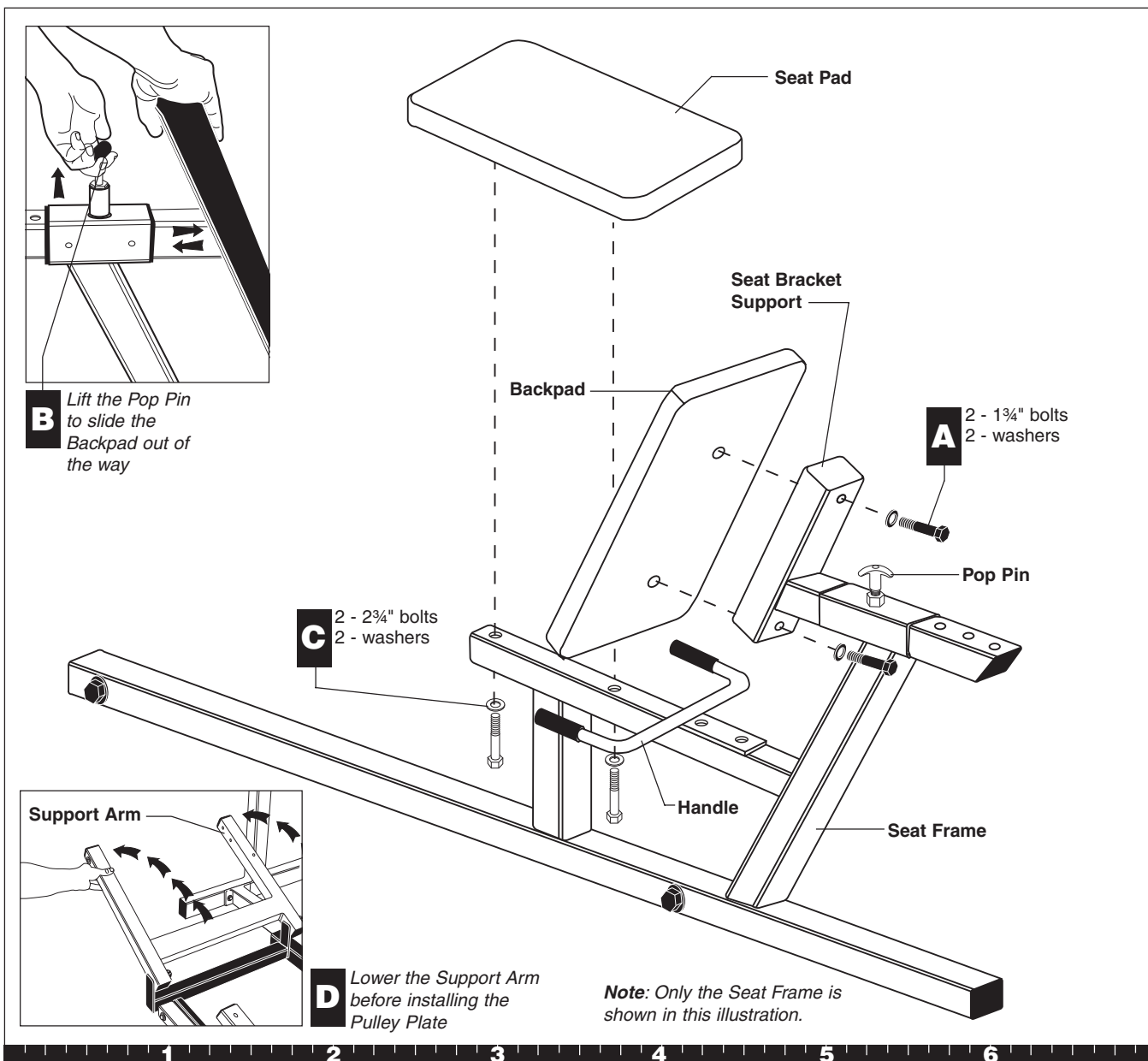

Step 3. Assemble the Seat Pads

4. Assemble the Pulleys

- A. Ensure that the Weight Pin has been pulled out of the Weight Stack.
- B. Attach the top and bottom portions of the Pulley Plate to the Side Upright using two 3-inch bolts, four washers, two locknuts. Wrench tighten.
- C. Mount one 3½-inch pulley to the top hole on the Pulley Plate using one 2½-inch bolt, two washers, one 3/8-inch barrel spacer, one 3½-inch cable retainer, one locknut. Finger tighten.
- D. Mount one 4½-inch pulley to the bottom hole on the Pulley Plate using one 2¾-inch bolt, two washers, one stop bracket, one 3/8-inch barrel spacer, one 4½-inch cable retainer, one locknut. Finger tighten.
- E. Have an assistant hold the Support Arm in an upright position. Mount one 4½-inch pulley to the Support Arm using one 4¼-inch bolt, five washers, one 3/8-inch barrel spacer, one 4½-inch cable retainer, one locknut. Finger tighten.

The illustration shows the proper orientation and fastener alignment.

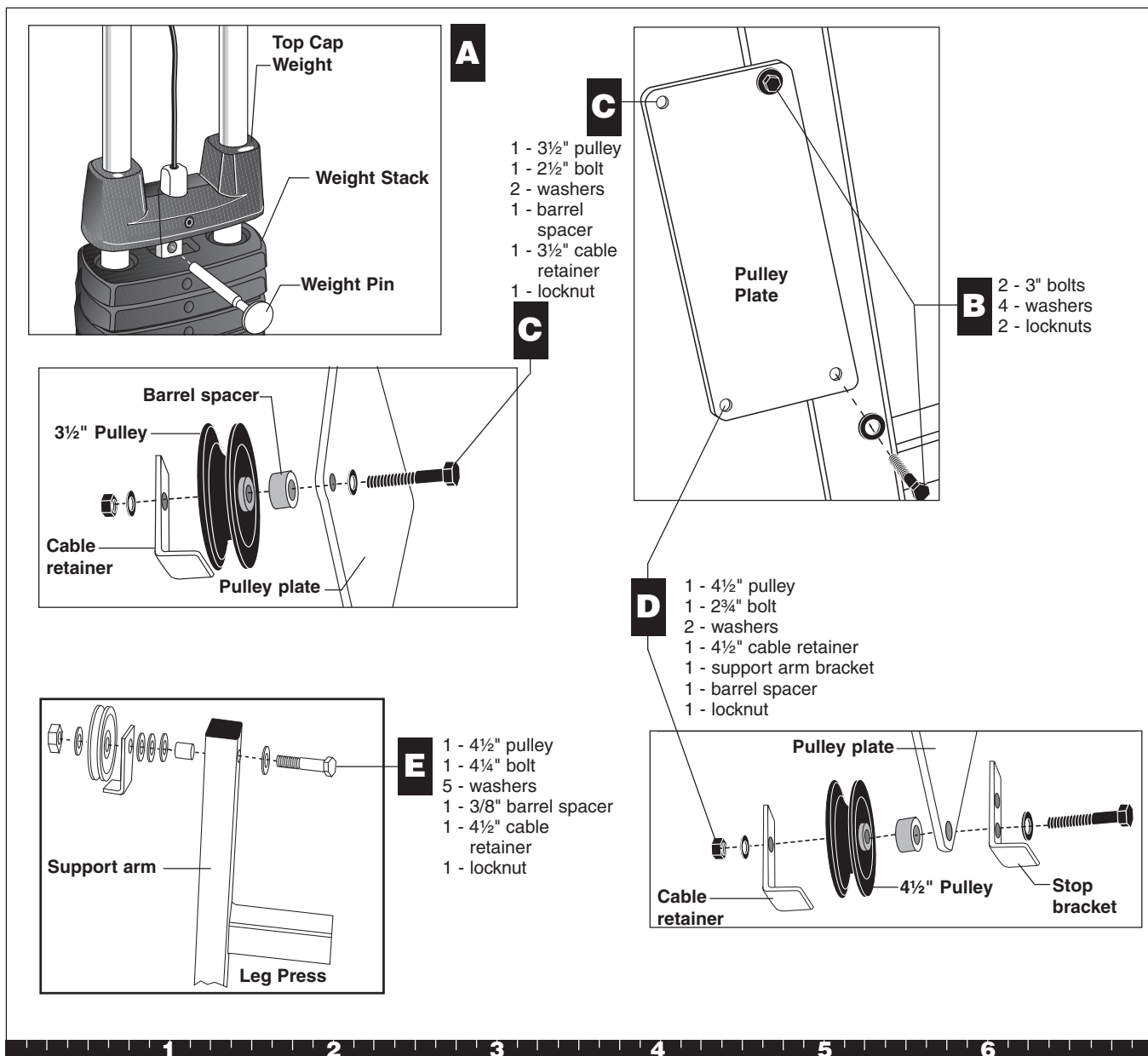

Step 4. Assemble the Pulleys

5. Route the Cable

A. Ask your assistant to continue to hold the Support Arm in a vertical position next to the Pulley Plate while you route the Cable.

B. Route the cable through the pulleys on the Pulley Plate. To release tension on the Cable while you pull the cable around the Support Arm pulley, have your assistant lift the Top Cap Weight (see the illustration on page 10). Adjust the cable retainers and make sure that the Cable moves freely before you tighten any bolts.

Note: The pulleys should be positioned with the edges in-line so that the cable moves freely. If a pulley is not aligned properly, you can adjust its position by using washers as spacers. Be sure that you always maintain a minimum 1/8-inch clearance between the bolt head and nearby structures.

C. Relocate the lower 3½" pulley on the Floating Pulley Plate. Loosen and remove the bolt and fasteners that secure the lower 3½" pulley to the Floating Pulley Plate. Reattach the pulley and fasteners onto the lowest hole on the Pulley Plate. Make sure that the Cable moves freely and then tighten the bolt securely.

D. Route the Cable. Properly adjust any cable retainers. Make sure that the cable moves freely before you tighten any bolts. Your assistant can let go of the Support Arm after the Cable is routed and secured.

E. Wrench tighten all pulley fasteners.

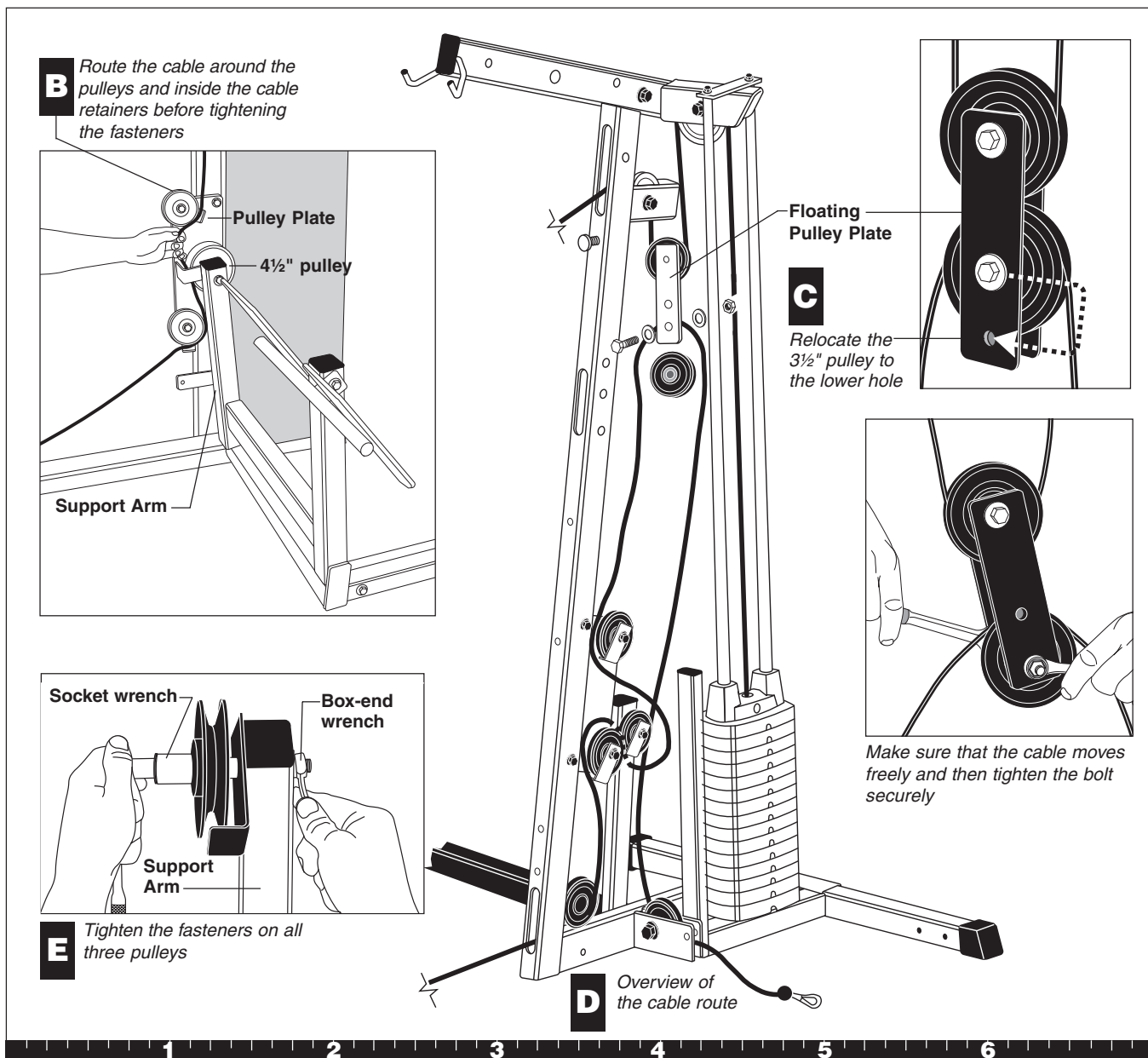

Step 5. Route the Cable

4

Cable Adjustments

After the Leg Press Option is fully assembled, you must check the cables for proper tension. Obvious signs that cable problems exist include:

- ✓ Excess slack exists in the Cable.
- ✓ The Top Cap Weight does not rest squarely on the Weight Stack.
- ✓ The Cable rubs the inside edges of the pulleys.

CAUTION: Take the time to perform the following steps. If the cables do not have the proper tension, you could damage the machine and void the Precor limited warranty.

Adjustments to the cable can be made in two places:

- the Press Arm Bumper Pad.
- the Rubber Bumper on the Support Arm.

Note: For adjustments to the Selector Stem, refer to your *Solana Assembly Instructions and Maintenance Guide*.

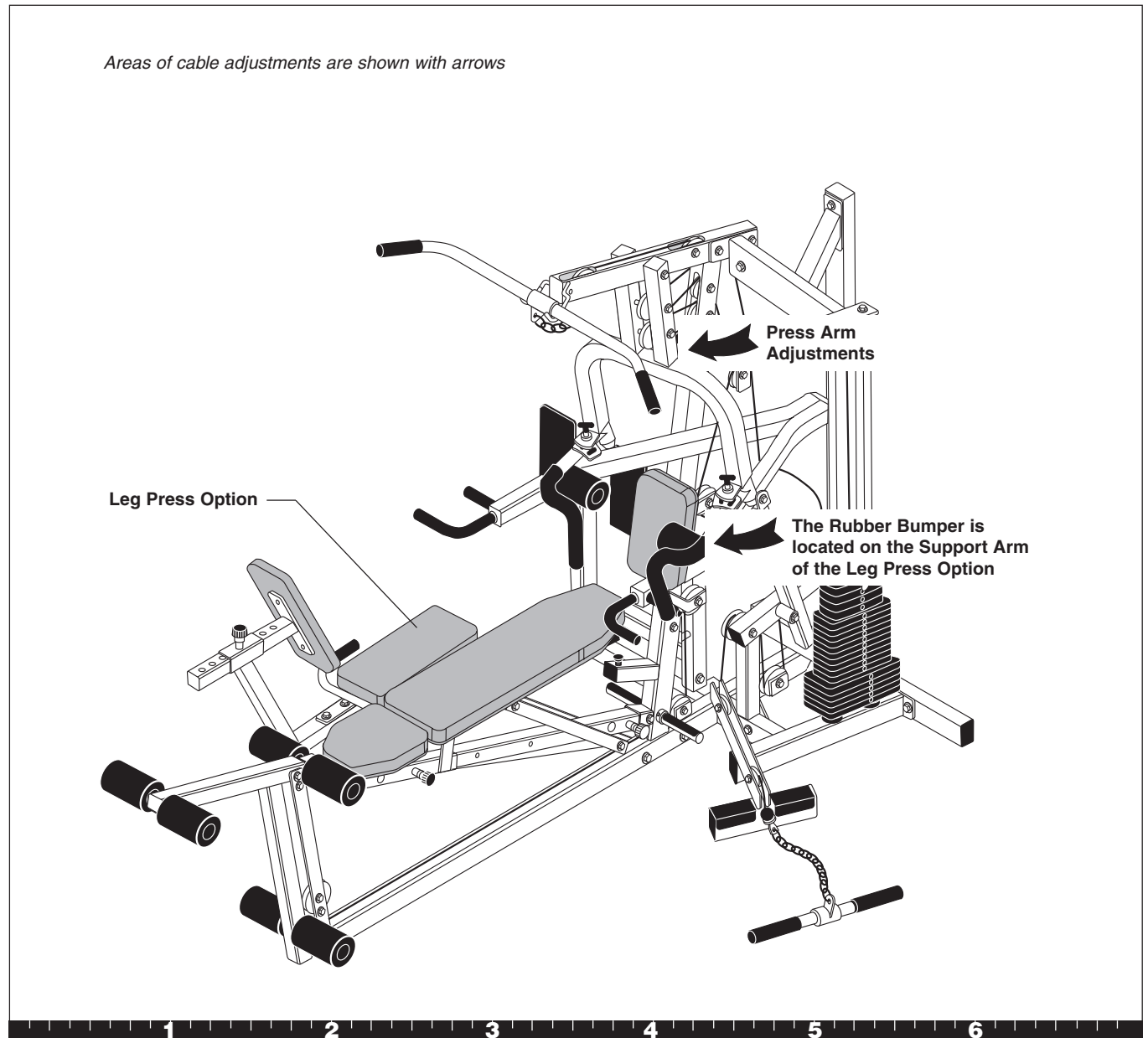

1. Press Arm Adjustment

- A. Place the Weight Pin in the Selector Stem under the Top Cap Weight to ensure the least Cable resistance.
- B. To adjust the tension of the Main Cable, rotate the Bumper Pad against the Press Arm.
- C. After properly adjusting the Cable tension, tighten the locknut against the Bumper Pad.
- D. Check the weights. Move the Weight Pin to each Weight and Selector Stem location.
- E. Replace the Weight Pin in the Top Cap Weight (see view A).

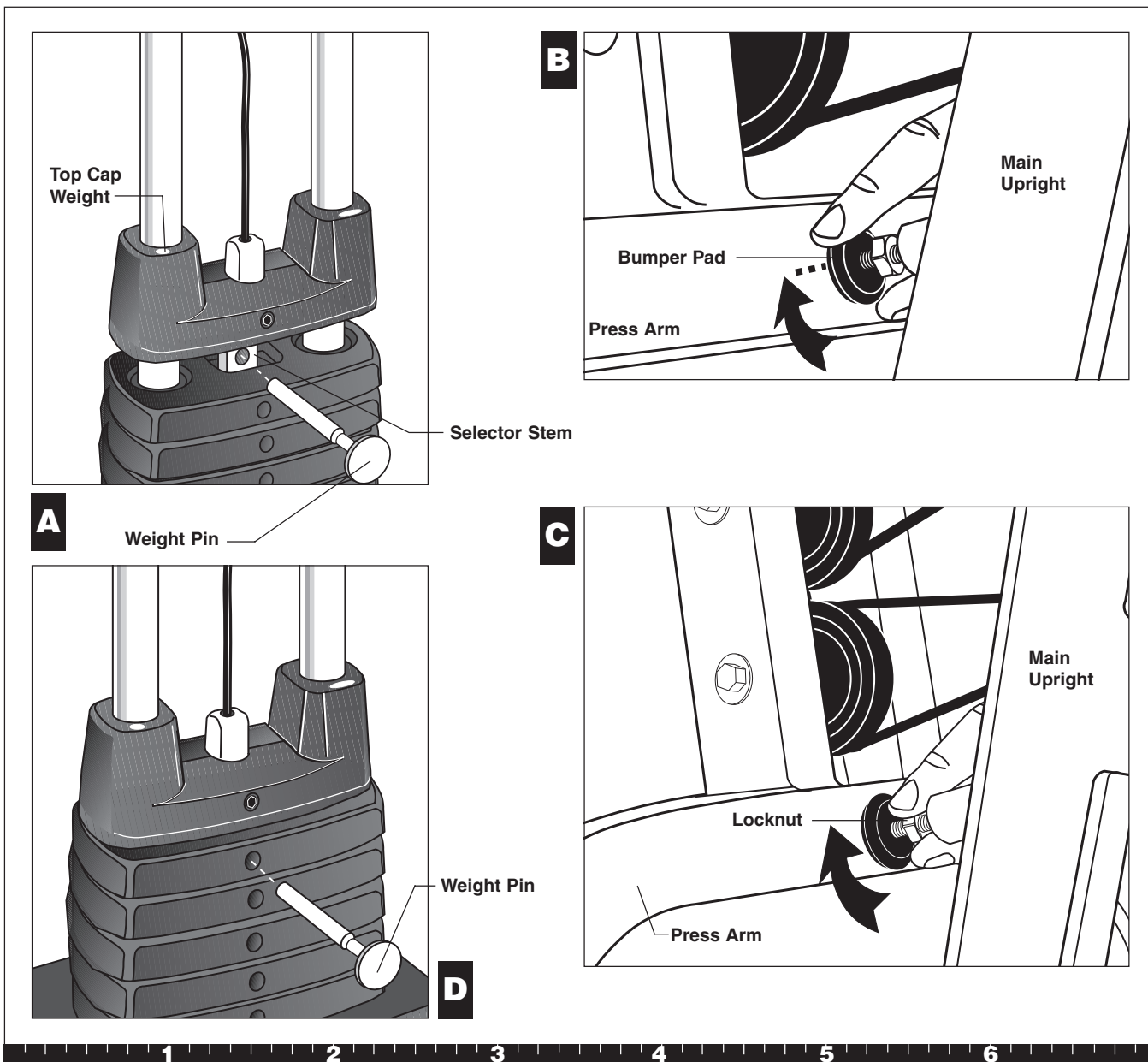

Step 1. Press Arm Adjustment

2. Support Arm Adjustment

- A. If the cable tension remains loose, rotate the Rubber Bumper on the Support Arm so that it presses against the Stop Bracket.
- B. Check the weights. Move the Weight Pin to each Weight and Selector Stem location.
- C. Replace the Weight Pin in the weight stack.

With the slack removed from the Cables, you are now ready to use the Leg Press Option. Thank you for choosing Pacific Fitness strength-training Equipment.

Note: For maintenance instructions, refer to your *Solana Assembly Instructions and Maintenance Guide*.

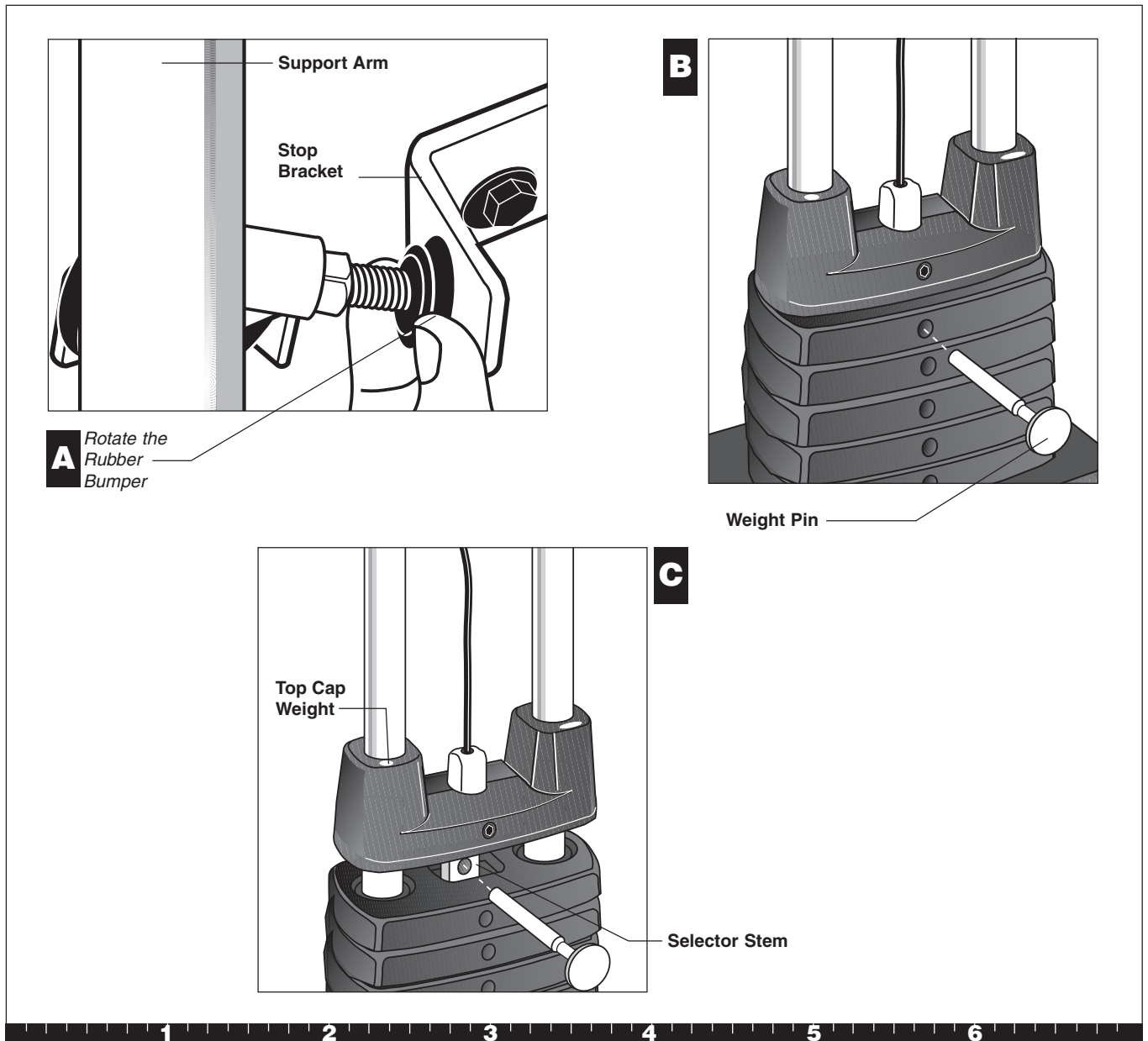

Step 2. Support Arm Adjustment

Residential Equipment Limited Warranty

Precor Incorporated warrants that all new Precor products are free of manufacturing defects in workmanship and materials. Parts repaired or replaced under the terms of this warranty will be warranted for the remainder of the original warranty period only. This warranty becomes effective at the invoice date of the original purchase.

Elliptical Fitness Crosstrainers and Motorized Treadmills (excluding EFX5.17 and Treadmills: 9.2 and 9.4 series) — Labor is covered for one year, parts are covered for five years plus a lifetime frame weld warranty covering parts-only repair or replacement parts. (Labor is not covered on frame replacement after one year.)

Products (StretchTrainer, Strength Equipment — formerly Pacific Fitness) other than Elliptical Fitness Crosstrainer and Motorized Treadmills (except options)

StretchTrainer — Labor is covered for a period of 90 days, parts are covered for a period of one year plus a lifetime frame weld warranty covering parts-only repair or replacement parts. (Labor is not covered on frame replacement after one year.)

Pacific Fitness Branded Strength Products and Precor Strength Products S3.xx

This is a parts only warranty. Labor costs are not covered.

1. Frame & Welds: Defective parts pertaining to frame structure, including all welded assembly parts, will be warranted for Lifetime.
2. Bearings, Guide rods, Cams, Pulleys, Belts, Cables, Hand grips, and Miscellaneous parts will be warranted for a period of three years. **Note that for the Precor Strength Products S3.xx, and the Pacific Fitness Solana and Zuma, the warranted period is five years.**
3. Upholstery will be warranted for a period of one year. A three month warranty applies to Naugahyde upholstery for Pacific Fitness Branded Strength Products only.

Return Policy: Proof of purchase is required to determine whether service on a Precor Strength Product/ Pacific Fitness Product during its warranty period will commence. Claims should be made to the dealer from whom you purchased the product. The purchaser is responsible for all transportation and insurance costs on returned or replaced equipment or parts. The purchaser also assumes any costs associated with the disassembling or reassembling of the replacement parts. **WARRANTY BECOMES VOID IF PRECOR FINDS THE DEFECT A RESULT OF INCORRECT INSTALLATION, MISUSE, LACK OF PROPER MAINTENANCE OR ANY MODIFICATION NOT APPROVED BY PRECOR.**

Options / Accessories / Battery-powered or Self-Operated Devices

Many options or accessories have components that are connected internally or mounted inside the electronic console. The following guidelines determine the warranty for these components. If the internal components are installed by the factory or by an authorized dealer as part of the original sale and delivery, they have a warranty that is identical to the warranty of the equipment in which they are connected or mounted. If the internal components are not installed by the factory or by an authorized dealer as part of the original sale and delivery, they have a 90 days parts and labor limited warranty. All components that are not internally connected have a 90 days parts only limited warranty. Satisfactory proof of purchase is required in all cases.

PRECOR'S SOLE LIABILITY IS LIMITED TO REPAIR OR REPLACEMENT OF PARTS ACCORDING TO THE TERMS AND CONDITIONS OF THESE LIMITED WARRANTIES, AND ANY IMPLIED WARRANTIES OF MERCHANTABILITY OR FITNESS FOR A PARTICULAR PURPOSE ARE LIMITED TO THE DURATION OF THE ABOVE WRITTEN WARRANTIES. IN NO EVENT WILL PRECOR OR THE SELLING DEALER BE LIABLE FOR INCIDENTAL OR CONSEQUENTIAL DAMAGES SUCH AS INCONVENIENCE, COMMERCIAL LOSS, LOST PROFITS OR DAMAGE TO OTHER PROPERTY.

Some states do not allow the exclusion or limitation of incidental or consequential damages, so the above limitation may not apply to you. This warranty gives you specific legal rights, and you may also have other rights which vary from state to state.

Keep this for your records. Purchased From: _____

Phone Number: _____ Product/Model: _____

Serial #: _____

Conditions

This warranty is valid only in accordance with the conditions set forth below.

1. Warranty applies to the Precor product only while
 - A) it remains in the possession of the original purchaser and proof of purchase is demonstrated,
 - B) it has not been subjected to accident, misuse, abuse, improper service, or non-Precor modification and
 - C) claims are made within the warranty period.
2. Warranty of all Precor products applies to residential use only (unless specifically stated by the factory, in writing, to be warranted for commercial use) and is void when products are used in a non-residential environment or installed in a country other than where sold.
3. This warranty does not cover damage or equipment failure caused by residential wiring not in compliance with electrical codes or Precor owner's manual specifications, or failure to provide reasonable and necessary maintenance as outlined in the owner's manual.
4. During the labor period Precor compensates Servicers for warranty trips within their normal service area to repair motorized treadmills and elliptical fitness crosstrainers at the customer's location. You may be charged a trip charge outside the service area, or for on-site warranty repairs, or for on-site warranty repairs of strength products, within the service area.
5. Precor Limited Warranty service may be obtained by contacting the authorized dealer from where you purchased the equipment or by contacting a Precor Factory Authorized Service Center, or by calling 1-800-4-PRECOR (1-800-477-3267).
6. Except in Canada, Precor does not pay labor outside the United States. Equipment limited warranty is void when equipment is installed in a country other than where sold. For specific warranty details, contact a local Precor dealer.

This Limited Warranty shall not apply to:

1. Software (PROM) limitations or corrections.
2. Batteries or other consumables, or cosmetic items, grips, seats, labels, or wheels.
3. Repairs performed on Precor equipment missing a serial number or with a serial tag that has been altered or defaced.
4. Service calls to correct installation of the equipment or instruct owners on how to use the equipment.
5. Pick-up, delivery, or freight charges involved with repairs.
6. Any labor costs incurred beyond the applicable labor warranty period.

Please fill out the Warranty Registration and mail it to Precor.



Residential Equipment Limited Warranty

Thank you for purchasing a PRECOR product. In order that we may continue to serve you in the future, please take a few minutes to complete and return this warranty registration.

The undersigned hereby acknowledges receipt of the Precor Limited Warranty and affirms that the date of purchase was 20____, further that the undersigned has read and understands the conditions and terms of the Precor Limited Warranty in its entirety. For your protection, complete the Precor Limited Warranty registration card within 10 days from date of purchase and mail it to Precor. In the event of a safety modification or for other reasons Precor might deem necessary, we will contact you directly.

Name of Facility _____

Contact Person _____ Mr. Ms.

Phone Number _____ - _____

Address _____

City _____ State _____ Zip Code _____

Purchased From _____

City _____ State _____ Zip Code _____ - _____

Serial # _____

Purchaser's Signature _____

Please detach and return this portion.

Serial number is located on the shipping box and on the product.

Please fill out the Warranty Registration and mail it to Precor.



Warranty Registration Card

PRECOR[®]
USA
Precor Incorporated
20031 142nd Avenue NE
P.O. Box 7202
Woodinville, WA USA 98072-4002

PLACE
STAMP
HERE

Solana Leg Press Option Specifications

Length: 56 inches (142 cm)

Height: 31 inches (79 cm)

Width: 36 inches (91 cm)

Shipping weight: 99 lb (45 kg)

PRECOR[®]
USA

Precor Incorporated
20031 142nd Avenue NE
P.O. Box 7202
Woodinville, WA USA 98072-4002

Precor and Pacific Fitness are registered trademarks of Precor Incorporated.
Specifications subject to change without notice.

Copyright 2001 Precor Incorporated. Precor web site: www.precor.com

NOTICE:

Precor is widely recognized for its innovative, award winning designs of exercise equipment. Precor aggressively seeks U.S. and foreign patents for both the mechanical construction and the visual aspects of its product design. Any party contemplating the use of Precor's product designs is hereby forewarned that Precor considers the unauthorized appropriation of its proprietary rights to be a very serious matter. Precor will vigorously pursue all unauthorized appropriation of its proprietary rights.

Leg Press Option Literature Kit # 44960-101
Leg Press Assembly Instructions # 44655-101
Exploded Views # 43683-102
Warranty Card # 36287-108
Effective date: September 24, 2001