

***Excel Two Bag Catcher
48"/54"/60" Decks
Operator's Manual***

EXCEL
INDUSTRIES

200 South Ridge Road • Hesston, Kansas • 67062

Table of Contents

General Information	1-1
To the New Owner	1-1
Using This Manual	1-1
Warranty Registration.	1-1
Parts and Service	1-1
Safety Precautions.	2-1
Safe Operation and Service Precautions	2-1
Safety and Instruction Decals.	2-1
Assembly Instruction	3-1
Required Tools	3-1
Parts List	3-1
Assembly	3-1
Operation	4-1
Vacuum Pickup and Collection.	4-1
Unloading the Catcher Bags	4-2
Transporting Mower With Catcher	4-2
Converting To Side Discharge Mode	4-2
Maintenance & Storage	5-1
Maintenance	5-1
Storage.	5-1
Two Bag Catcher Warranty Policy.	6-1
Parts Manual	7-1

GENERAL INFORMATION

To the New Owner

The purpose of this manual is to assist owners and operators in maintaining and operating the Excel Two Bag Catcher. Please read it carefully; information and instructions furnished can help you achieve years of dependable performance.

Using This Manual

General operation, adjustment and maintenance guidance is outlined for both the experienced and novice Excel user. Operating conditions vary considerably and cannot all be addressed individually. Through experience, however, operators should find no difficulty in developing good operating skills suitable to most conditions.

Directions used in this manual, for example RIGHT or LEFT, refer to directions when in operator position and facing forward, unless otherwise stated.

Photographs and illustrations used were current at the time of printing, but subsequent production changes may cause your machine to vary slightly in detail. Excel Industries, Inc. reserves the right to redesign and change the machine as deemed necessary, without notification. If a change has been made to your machine which is not reflected in this operator's manual, or the parts manual, see your Excel Dealer for current information and parts.

Warranty Registration

Your Excel Dealer must register the unit on-line within **ten (10) days** following date of purchase to validate your warranty protection. As the new equipment owner, you should confirm that your Excel Dealer has registered your catcher with Excel Industries, Inc.

IMPORTANT: Any unauthorized modification, alteration, or use of non-approved attachments voids the warranty and releases Excel Industries, Inc. from any liability arising from subsequent use of this equipment. Do not use or operate any attachment not approved by Excel Industries, Inc..

Parts and Service

Use original Excel replacement parts only. These parts are available through your local Excel Dealer. To obtain prompt, efficient service, always provide the following information when ordering parts:



1. Correct part description and number, as given in the parts manual supplied with your owner's packet.
2. Correct model number.



All warranty repair and service must be handled through an authorized Excel Dealer. Arrangements should be made through your local service center.

SAFETY PRECAUTIONS



This safety alert symbol is used to call attention to a message intended to provide a reasonable degree of **PERSONAL SAFETY** for operators and other persons during the normal operation and servicing of this equipment.

	DANGER	
– denotes immediate hazards which WILL result in severe personal injury or death.		

	WARNING	
– denotes a hazard or unsafe practice which COULD result in severe personal injury or death.		

This manual uses two other words to highlight information. **IMPORTANT** calls attention to special mechanical information and **NOTE** emphasizes general information worthy of special attention.

All operators and mechanics should read this manual, and be instructed about safe operating and maintenance procedures. If the operators or mechanics cannot read and understand English, it is the owner's responsibility to explain this material to them.

Improper use or maintenance by the operator or owner can result in injury. To reduce the potential for injury, comply with these safety instructions and always pay attention to the safety alert symbol "▲", which means DANGER or WARNING - "personal safety instructions." Failure to comply with the instructions may result in personal injury or death.

Incorrect usage of this attachment may result in severe injury. Personnel operating and maintaining it should be trained in the proper use and should read the manuals completely and thoroughly before attempting to set-up, operate, adjust, or service this mower.

Safe Operation and Service Precautions

- ▲ All operator's should be familiar with the mower's operator's manual, particularly the operational and safety instructions contained in this manual.
- ▲ Evaluate the terrain to determine what accessories and attachments are needed to properly and safely perform the job. Only use accessories and attachments approved by the manufacturer.
- ▲ Always stop on level ground, disengage deck clutch, place steering control lever in the park brake position, stop engine and remove ignition key before leaving oper-

ator's seat for any reason including emptying the catcher bags or unclogging the chute.

- ▲ Always be aware of any obstructions, especially small children, when backing or unloading the bags.
- ▲ Always keep safety shields and covers in place, except for servicing.
- ▲ Never work on mower deck when the engine is running.
- ▲ Never operate machine with the catcher lid in the raised position except for unloading.
- ▲ Never attempt high speed maneuvering in crowded or congested areas.
- ▲ Always be aware that the catcher hangs off the rear of the mower, thereby increasing the length of the mower. Use caution when backing up or turning when the catcher is mounted to the mower.
- ▲ When the catcher is used, any rapid movement of the control levers in either direction could result in a reaction of the mower that can cause serious injury.
- ▲ Always operate with complete catcher system, mulching system or side discharge chute in place and in the lowest position.
- ▲ Never operate the mower with the catcher system installed without the bags being properly installed and the catcher lid in the lowered position.
- ▲ Always keep clear of the mower blades and attachments during their operation.
- ▲ Turn off blades when not mowing.
- ▲ Stop the engine before removing the grass catcher or unclogging the discharge chute. Never clear the discharge chute with the engine running. Turn off the engine and be sure the blades have stopped before cleaning. Use a stick to clear a plugged discharge area. **Never use your hand!**
- ▲ **Clean flammable material from machine. Prevent fires by keeping engine compartment, exhaust area, battery, fuel line, fuel tank and operator's station clean of accumulated trash, grass clippings, and other debris. Always clean up spilled fuel and oil.**
- ▲ Grass collection system components are subject to wear, damage and deterioration, which could expose moving parts or allow objects to be thrown. Frequently check components and replace with manufacturer's recommended parts when necessary.
- ▲ Never direct discharged material toward anyone. Avoid discharging material against a wall or obstruction. Material may ricochet back towards the operator. Always disengage the blades and wait for them to stop before crossing gravel drives, walks or roads.

Safety and Instruction Decals

The decals are designed to give the operator brief information needed in the daily operation and service of the mower. These decals are not intended to be used in place of this manual but instead are to be used as an extension of this manual. These decals should not be removed or obliterated. Replace these decals if they become unreadable.

- It is the **owner's responsibility** to make certain that the operators and mechanics read and understand this manual and all decals before operating this mower.
- It is also the **owner's responsibility** to make certain that the operators and mechanics are qualified and physically able individuals, properly trained in the operation of this equipment.
- All operators and mechanics must become familiar with the safe operation of the equipment, operator controls and decals.
- Never let children or untrained people operate or service the equipment. Local regulations may restrict the age of the operator.
- The owner/user can prevent and is responsible for accidents or injuries occurring to themselves, other people or property.
- The owner should also ensure that the operators/mechanics know that they are responsible for their own safety as well as the safety of other persons within the vicinity. **Remember**, the operator is responsible for accidents or hazards occurring to other people or their property.

A brief explanation, for those requiring one, is shown to help the operator understand the meanings of these decals.



- **Read Operator's Manual and Safety Warning Decals before attempting to operate this machine.**

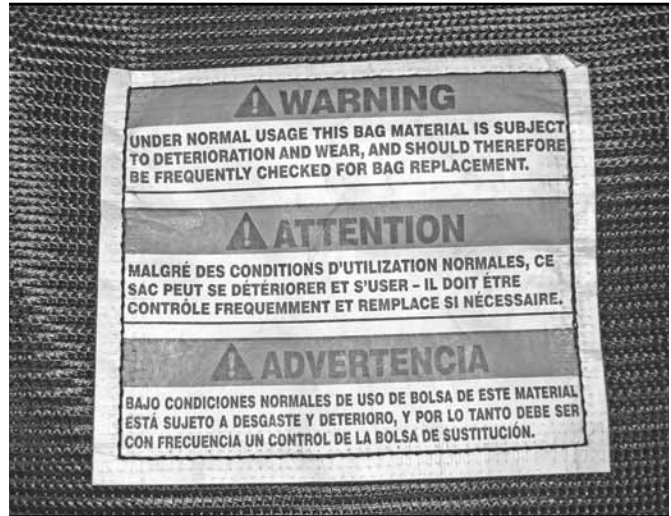

- **Under normal usage this bag material is subject to deterioration and wear, and should therefore be frequently checked for bag replacement.**

WARNING

Specific safety warning decals are located on the equipment near the immediate areas of potential hazards. These decals should not be removed or obliterated. Replace them if they become non-readable.

Refer to the mower's operator's manual for illustrations showing the various safety decals that are located on the mower.

<p style="text-align: center;">WARNING: Thrown objects!</p> <ul style="list-style-type: none"> • Never operate the mower deck with side deflector damaged, altered, removed or in raised position, except when the entire grass catcher attachment or mulching system is being used. 	<p style="text-align: center;">Part Number 604221</p>	<p>DANGER: Rotating blades, pulleys & belts</p> <ul style="list-style-type: none"> • Keep shields and covers in place while machine is in operation • Keep hands, feet and clothing away from rotating pulleys and belts.
---	--	--

ASSEMBLY INSTRUCTION

These instructions apply to the assembly of the Excel Two Bag Catcher to an Excel 48", 54" or 60" mower.

It is intended that these units be installed by trained Excel service personnel. If additional assistance is required, contact the Excel Customer Service Department.

Directions given in these instructions, for example left and right, refer to direction while seated on the mower.

Before proceeding, read through the following instructions to familiarize yourself, while at the same time identify and inventory kit parts supplied.

Unpack and inspect all parts. Notify carrier of any shipping damages immediately.

Required Tools

The following is a list of the tools required to assemble the catcher to the mower.

- Tape measure
- One 3/8" combination wrench or socket
- Two 9/16" combination wrench or socket
- Torque wrench (with 118 Ft.-lb. range) with a 15/16" hex socket

Parts List

PART NO.	DESCRIPTION	QTY.
N/A	2 BAG LID	1
N/A	CATCHER CHUTE	1
N/A	1.6 BUSHEL BAG	2
796649	BLADE, 16.50"-CAT-F-CW (48" DECK)	1
602416	BLADE, 18.50"-CAT-F-CW (54" DECK)	1
793935	BLADE, 20.50"-CAT-F-CW (60" DECK)	1
117394	CATCHER FRAME	1
604387	UPPER CHUTE	1
604301	TIE ROD	2
117303	LS SUPPORT GUSSET	1
117304	RS SUPPORT GUSSET	1
029629	CAP SCREW (CS) .375-16 X .75 HX FLK	6
016899	NUT .375-16 HX FLK ZNYC	6
086660	NUT .375-16 HX ZY NL	2
023036	HAIR PIN .148 X 2.69 ZN	2
604887	CE .375 x 3.00 WITH BALE	2
604806	PLASTIC CAP - TANK	1
000331	WIRE TIE	2
120864	LATCH SUPPORT	1
025395	CB .375-16 X 1.00G5 ZNY	4
054502	NT .375-16 HX G5 ZNY	4
068551	NT .25-20 HX ZY NL	1
604475	ELASTIC STRAP	1
704916	CS .25-20 X 1.25 HX G5	1
767954	FW .379 X .813 X .063 SAE	4
768515	FW .281 X .625 X .051/.080 HD ZN/YL	2

NOTE: Refer to the *Parts Manual* section (starting on page 7-1) of this manual for more detailed parts information.

Assembly

NOTE: Refer to illustrated parts listings when assembling the unit.



WARNING



Allow engine and muffler to cool before assembling the catcher to the mower.



WARNING



Never work under the machine or attachment unless it is safely supported with jack stands. Make certain machine is secure when it is raised and placed on the jack stands. The jack stands should not allow the machine to move when the engine is running and the drive wheels are rotating. Use only certified jack stands. Use only appropriate jack stands, with a minimum weight rating of 2000 pounds to block the unit up. Use in pairs only. Follow the instructions supplied with the vehicle stands.

1. Park the mower on a flat surface. Always place the deck clutch switch in the **disengaged position**, place the steering control levers in the park brake position, shut off the ignition switch and remove the key from the switch. Disconnect the negative battery cable.
2. Raise the front of the mower and deck up until the blades can be accessed easily. Place the mower on jack stands and do not allow the mower to move. Chock the rear wheels.



WARNING



Mower blades are sharp and can cut. Wrap the blade(s) or wear gloves and use extra caution when servicing them.

3. Remove the right side blade and replace it with the new blade. The catcher is provided with one blade for each deck size. Use the appropriate blade as indicated by the label on the blade and discard the other blades. Figure 3-1 **Torque blade bolt to 118 ft.-lbs. (160 N-m).**

IMPORTANT: Only use a torque wrench when tightening and torquing the blade bolts.

NOTE: Retain the original blade as it will be re-used when the mower is converted back to the side discharge mode.



WARNING



Failure to correctly torque the bolt may result in the loss of the blade which can cause serious injury.

4. Remove the jack stands and lower the mower.
 5. Remove the tie rods from the catcher frame. The tie rods are embedded with the catcher frame for shipping purposes only.
 6. Attach the catcher frame to the rear of the mower. **Do not tighten** the mounting bolts at this time. Figure 3-2
- NOTE:** Some mower models have a taller rear engine guard. If a catcher is being attached to one of these models, it will be necessary to remove the engine guard. Figure 3-3

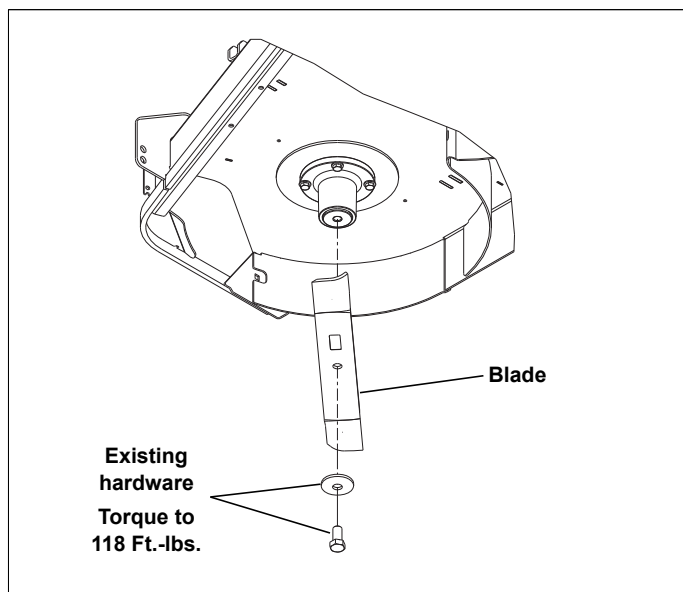

Figure 3-1

7. Raise the seat platform.
8. Unbolt the mower's fenders from the mower frame. There are four bolts per fender that will need to be removed. Figure 3-5

This allows the fenders to be moved to provide access to the mower frame. It is not necessary to remove the fenders from the mower.

NOTE: It will be necessary to unscrew the fuel cap from the fuel tank fill neck and slide the plastic cap over the fill neck opening. The plastic cap will slide over the fuel cap's tether line. This will allow the left fender to move enough to allow access to the hole in the mower frame. Figure 3-4

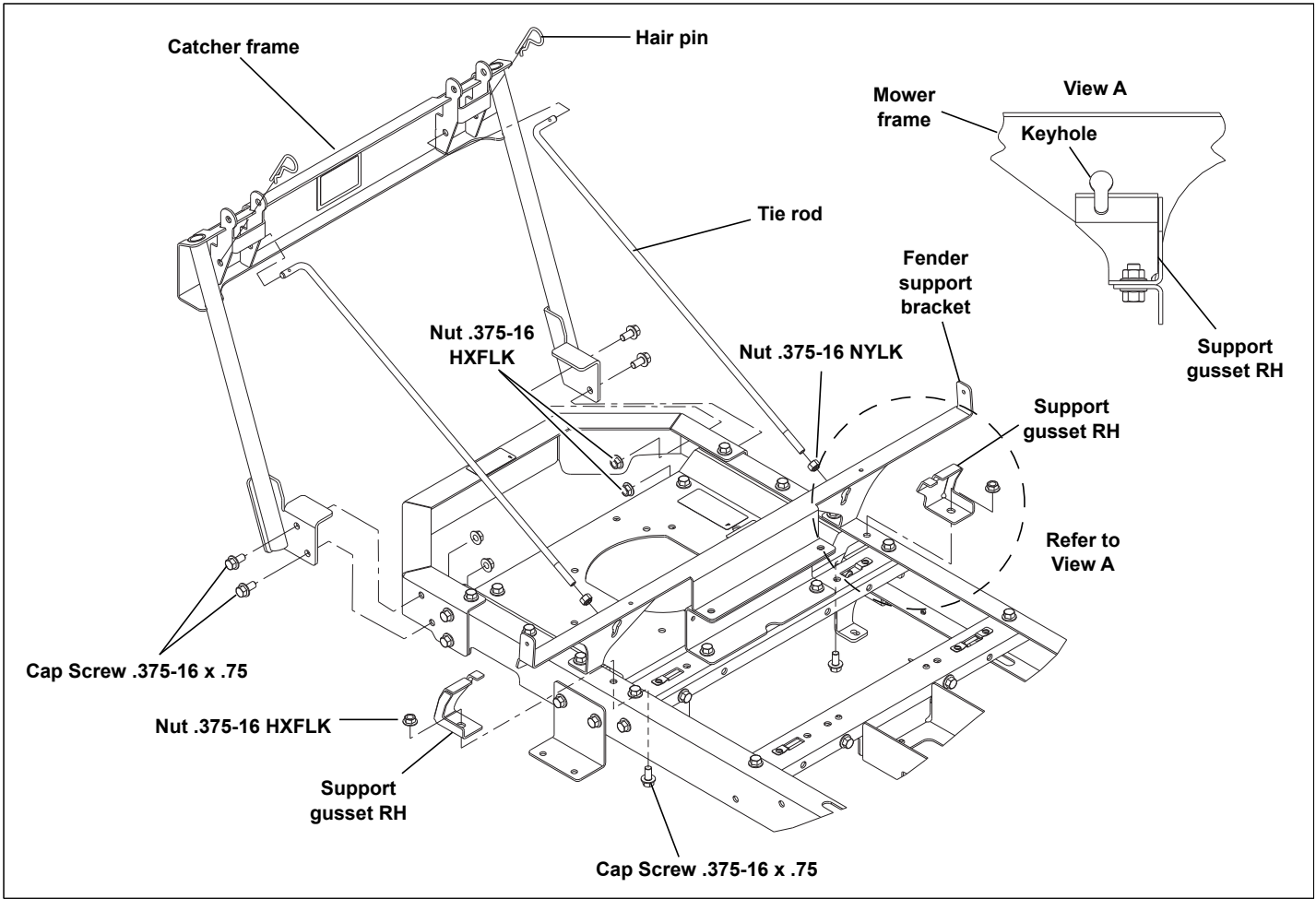

Figure 3-2

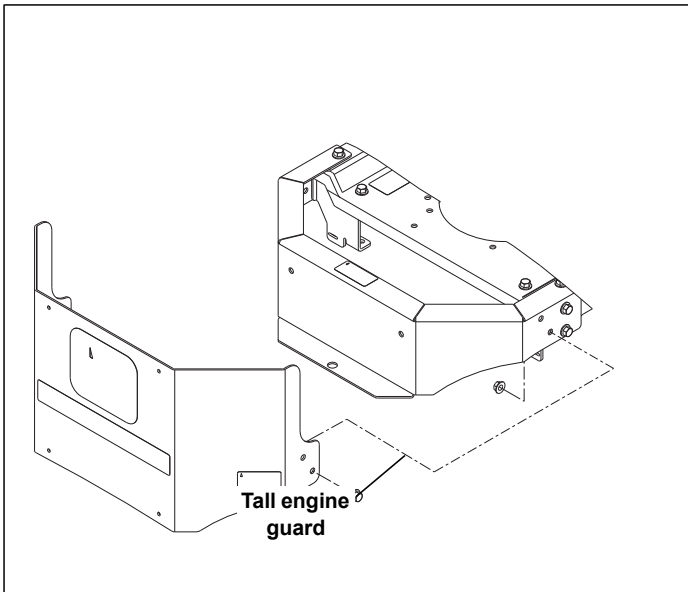

Figure 3-3

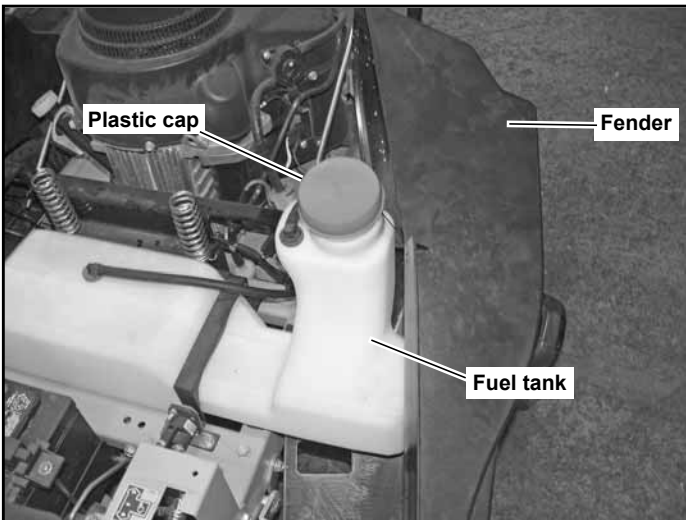
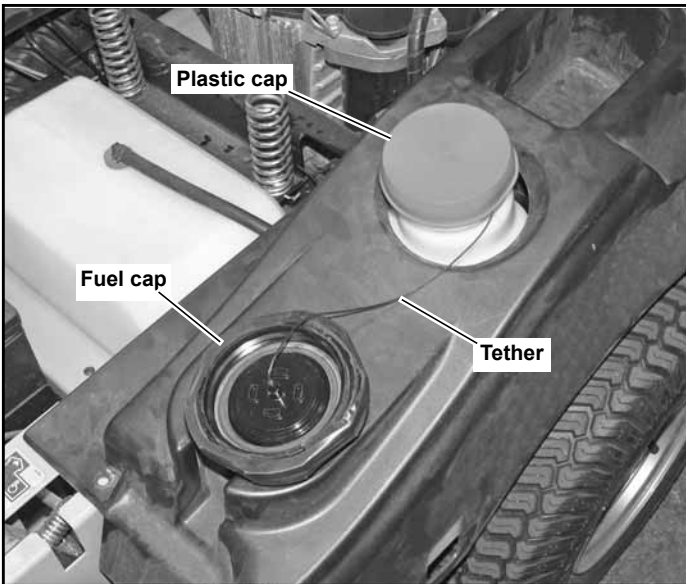
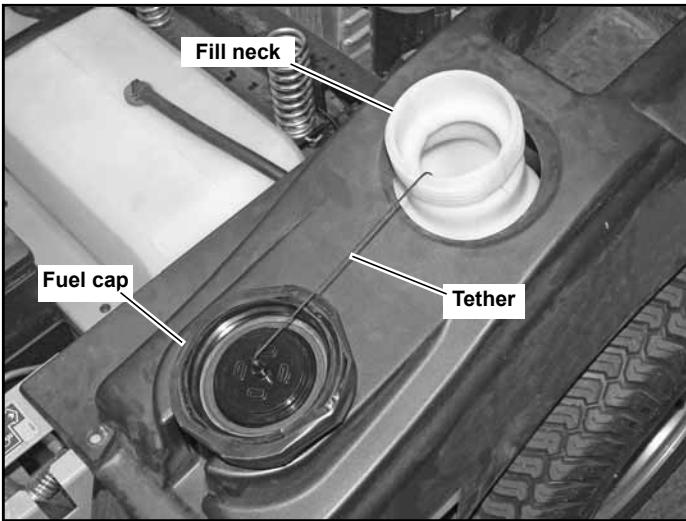

Figure 3-4

NOTE: It is not necessary to remove the control panel from the right fender. There should be sufficient access to the frame with the fender loose.



WARNING



When performing this step heed the warnings listed below:

- Do not smoke while the fuel cap is not properly secured to the fuel tank fill neck. Extinguish all cigarettes, cigars, pipes and other sources of ignition.
- Use extreme care when handling gasoline which is extremely flammable and vapors are explosive. A fire or explosion from fuel can burn you and others and can damage property.
- **Do not remove the fuel cap with engine running or while engine is hot.** Clean up any fuel spills.
- If fuel is spilled on clothing, change clothing immediately.

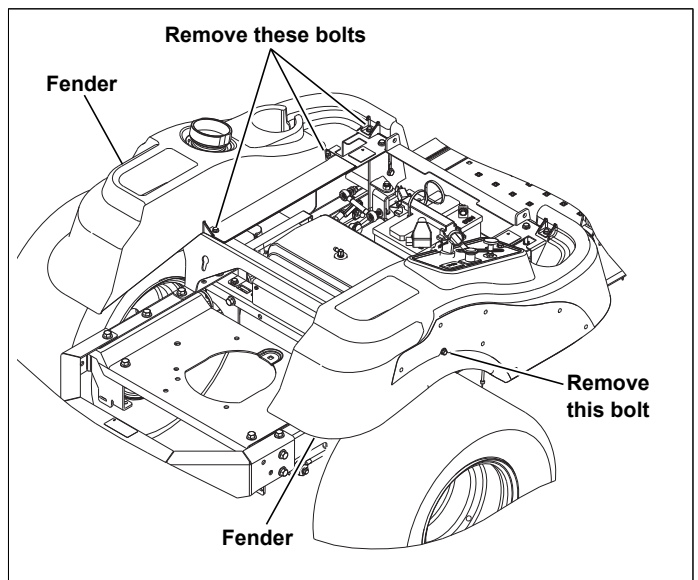

Figure 3-5

9. Attach the support gussets to the mower frame. The slots in the support gussets must align with the keyhole slots in the fender support bracket. Assemble the hardware as shown with the cap screw inserted from the bottom. Figure 3-2 View A

IMPORTANT: Be sure not to cut or pinch the fuel line when installing gussets.

10. Thread a .375-16 nylon locking nut onto each of the tie rods to the dimension shown in Figure 3-2 & Figure 3-6

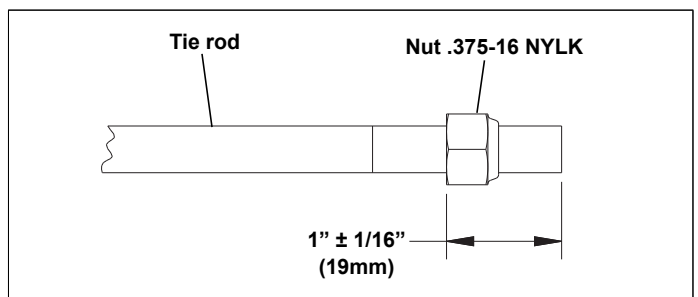

Figure 3-6

11. Insert one tie rod through the key hole slot in the fender support bracket and into the slot in the support gusset.

Make sure the nut on the tie rod is inserted through the slot in the support gusset. Figure 3-2 & Figure 3-6
 The nut end of the tie rod can be easily inserted through the upper end of the slot if positioned horizontally then angled upwards after the nut clears the support gusset. Figure 3-2 & Figure 3-6

IMPORTANT: Be certain that the nut does not catch or pinch the vapor line.

Then, insert the tie rod through the proper hole in the catcher frame and secure with a hair pin. Figure 3-2

Repeat for the other side.

12. Push down on the catcher frame and tighten the lower frame bolts. Pushing down on the catcher frame while tightening these bolts will provide the correct tension on the tie rods. Figure 3-7

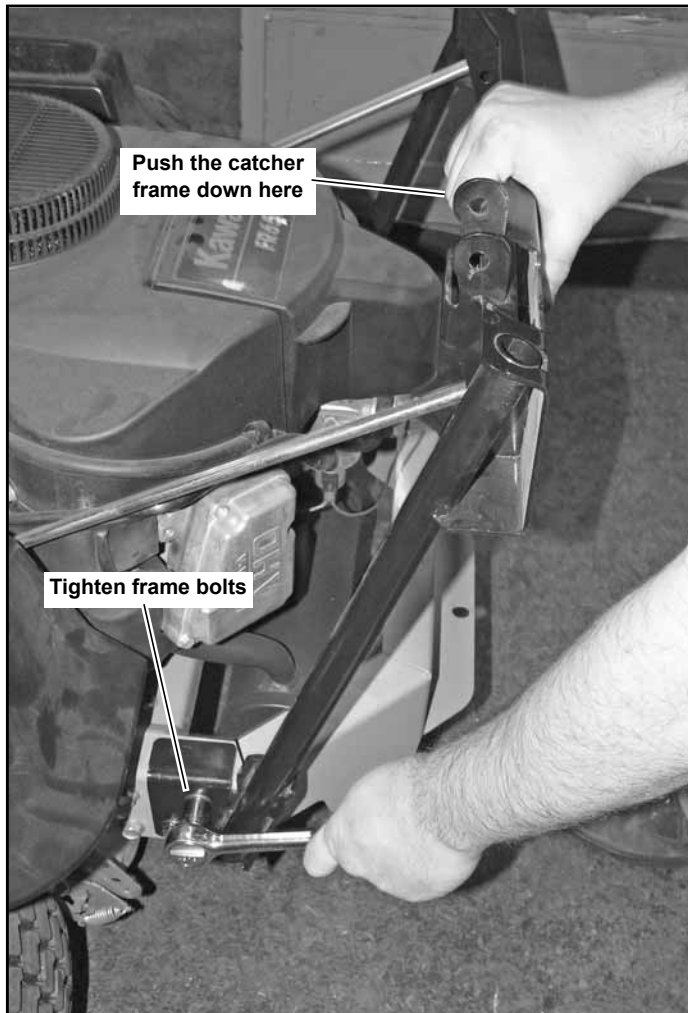

Figure 3-7

13. Secure the vapor lines using the zip ties as shown. You **must** secure the vapor lines to prevent them from rubbing on the tie rods. Remove the excess zip tie. Figure 3-8 & Figure 3-9

IMPORTANT: Make sure the vapor line does not become pinched and retains its original routing as it comes out of the top of the fuel tank. Figure 3-10

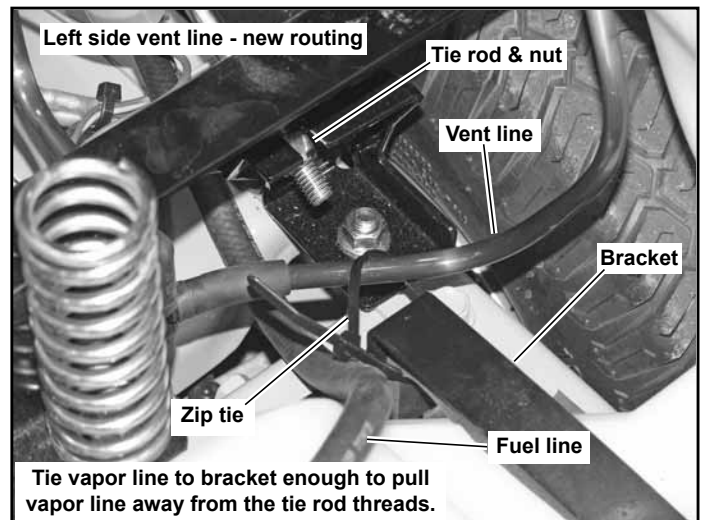
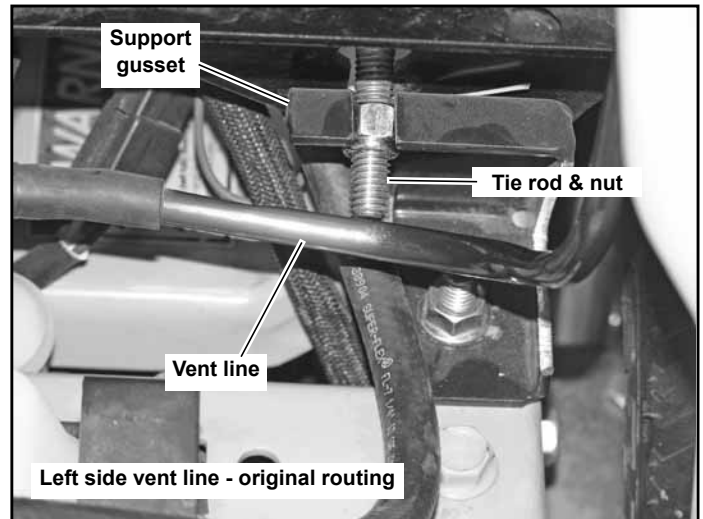

Figure 3-8

14. Re-attach the fenders to the mower frame. **Do not overtighten** the mounting hardware. Figure 3-5

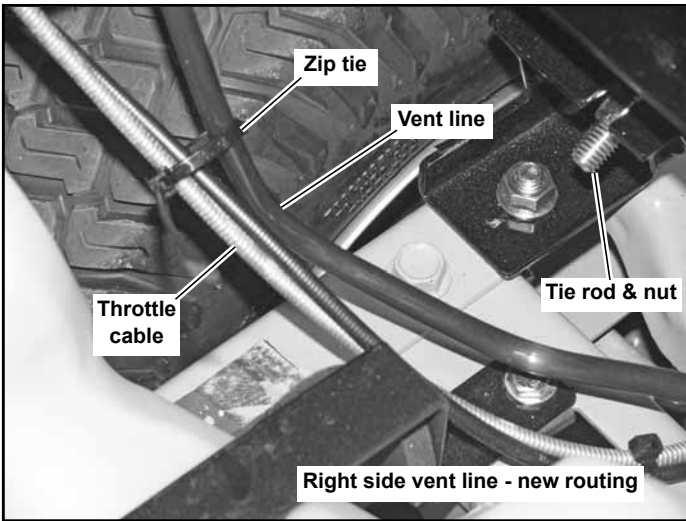
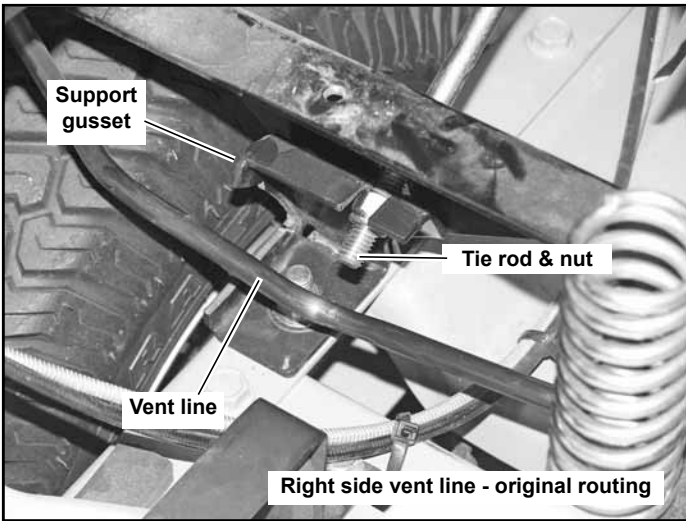



Figure 3-9

15. Remove the plastic cap from the fill neck opening and screw the fuel cap onto the fill neck. Figure 3-4



WARNING



Never operate the mower without the fuel cap threaded tightly onto the fill neck.

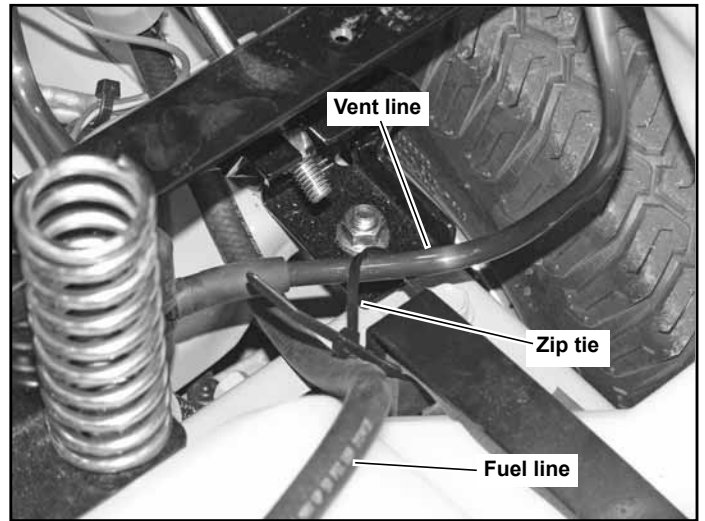

Figure 3-10

16. Attach the latch support to the catcher frame as shown in Figure 3-11.
- NOTE:** If the four (4) mounting holes are not present in the catcher frame, locate and drill four (4) .406" diameter holes in the frame per Figure 3-11.
17. Attach the elastic strap to the latch support. Orientate the elastic strap as shown. Figure 3-11

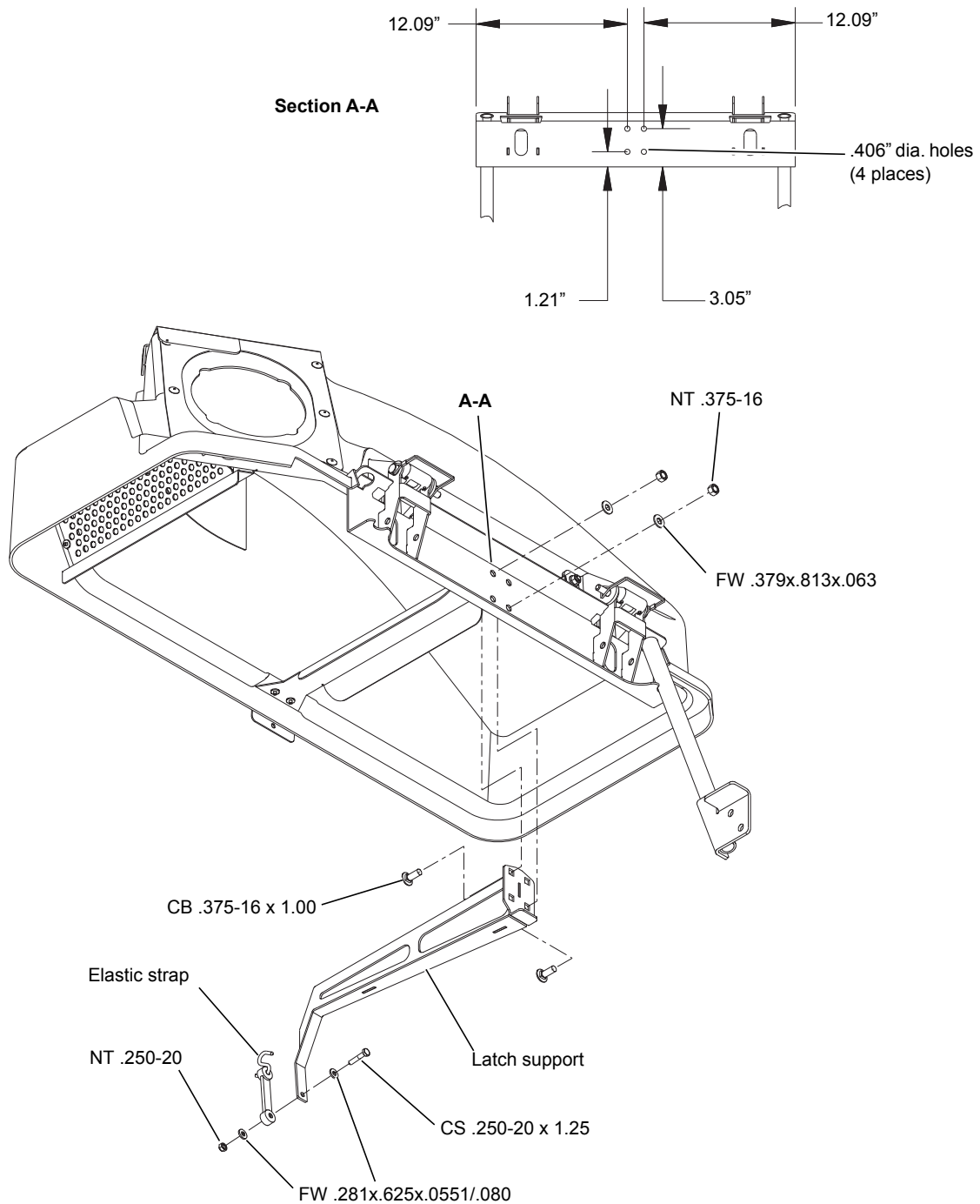

Figure 3-11

18. There is one tab located at the rear side of the deck that will need to be bent inward. Use a hammer and screwdriver to bend the tab inward enough to allow the steel hooks of the elastic latch on the outlet tube to be inserted into the slot. Figure 3-12, Figure 3-13 & Figure 3-14
19. Raise the deck discharge chute to the full up position (90°) and slide the outlet tube into position.

It will be necessary to force the discharge chute to the 90° position. The chute will contact the mower fender before the 90° position is attained. Push on the discharge chute until the chute is open enough to allow the tab of the outlet tube to be inserted into the slot in the discharge chute bracket of the deck. The downward spring force of the discharge chute helps to secure the outlet tube to the deck by locking the bump on the outlet tube with the cams of the discharge chute. Figure 3-15 & Figure 3-16

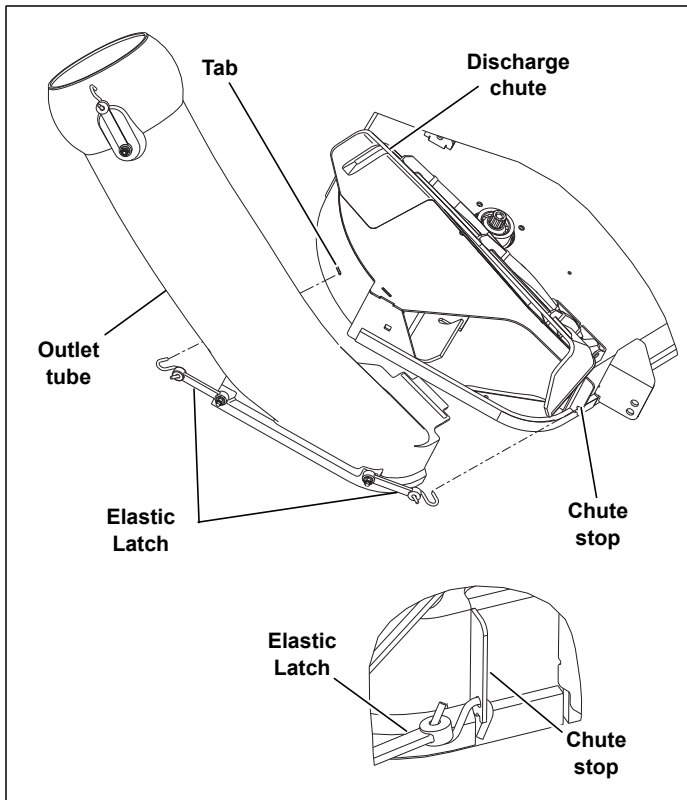

Figure 3-12

Secure the outlet tube in place with the elastic latches. Figure 3-12

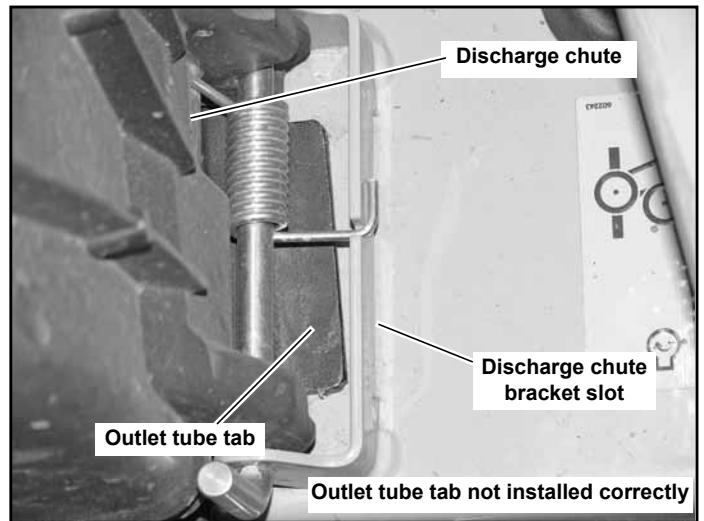

Figure 3-15

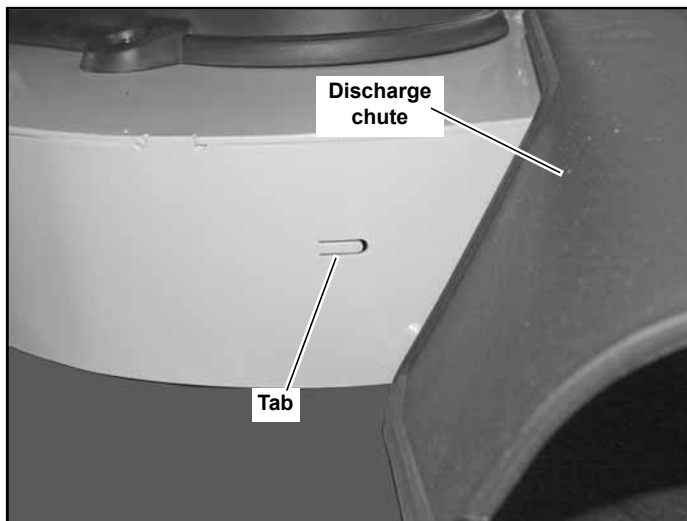

Figure 3-13

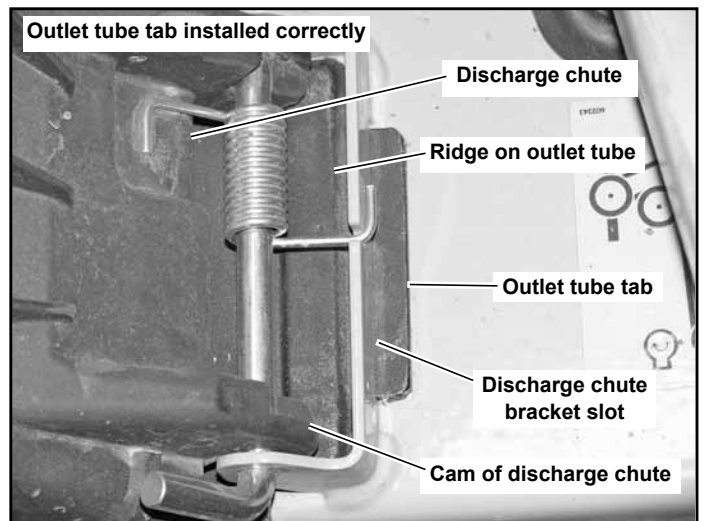

Figure 3-16

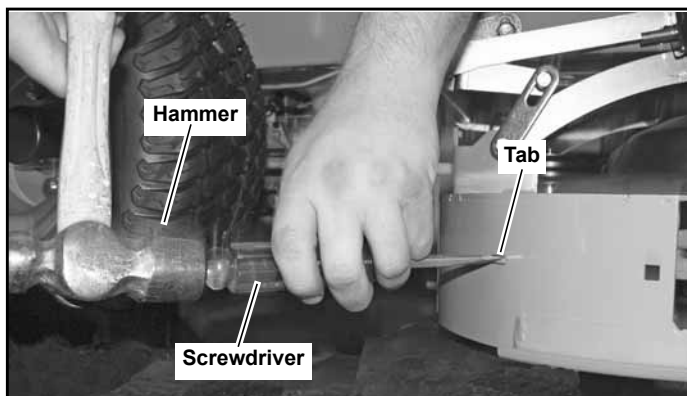

Figure 3-14

20. Slide the end of the transfer tube into the opening in the catcher lid. Figure 3-17
21. Place the bags on the catcher frame by inserting the bag frame hook into the catcher frame slot. Figure 3-20
22. Attach the catcher lid to the catcher frame using the CE .375 x 3.00 with bale pins. Close the catcher lid. Figure 3-21
NOTE: It is easier for two people to attach the catcher lid to the catcher frame than it is for one person.
23. Attach the transfer tube to the outlet tube by aligning the slot on the transfer tube with the knob on the outlet tube and hooking the elastic latch through the loop of the transfer tube. Figure 3-18 & Figure 3-19

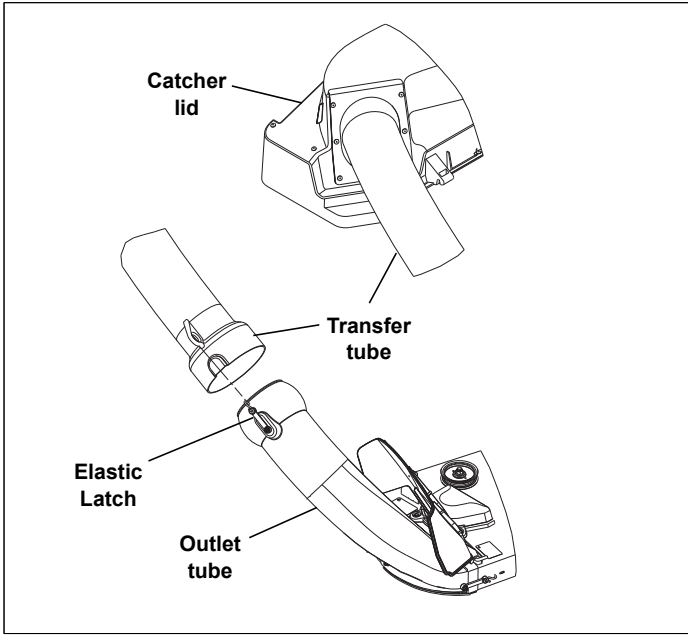

Figure 3-17

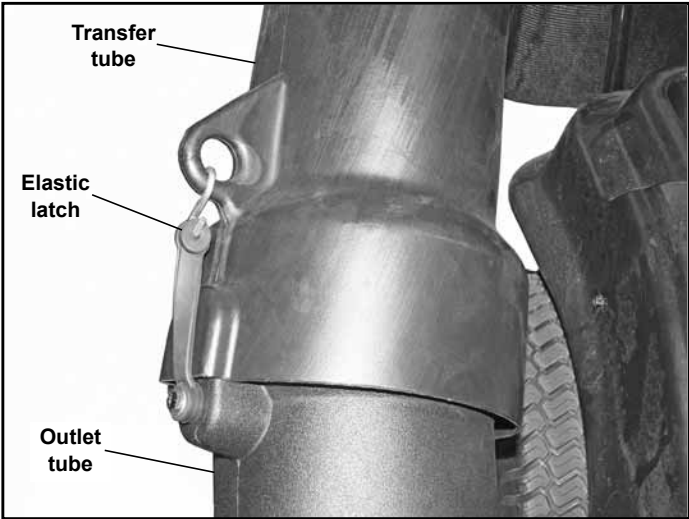

Figure 3-19

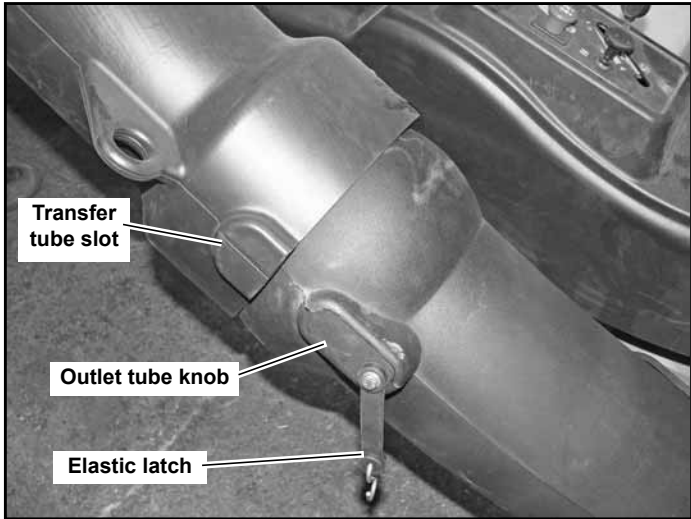

Figure 3-18

24. Reconnect the negative battery cable.

WARNING

Do not operate deck without discharge chute or complete catcher system in place.

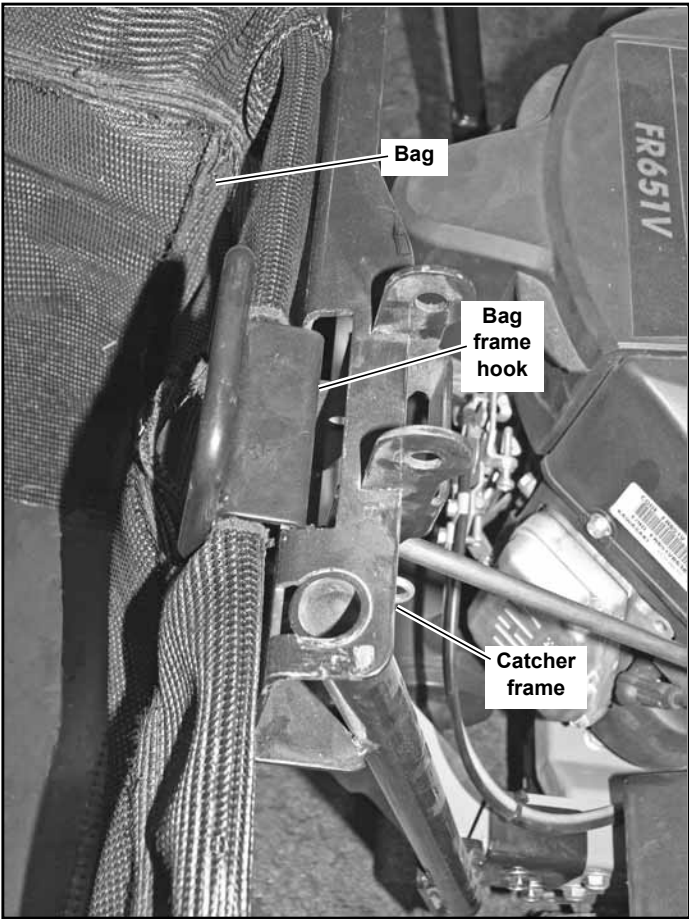

Figure 3-20

OPERATION

Vacuum Pickup and Collection

Follow normal mower start-up and operating procedures as outlined in the mower operator's manual. Whenever the deck clutch switch is engaged there will be debris moving through the catcher system.

The following list contains useful information when using the catcher:

- When catching, use the left side of the mower for trimming to prevent damage to the discharge chute and outlet tube.
- Catching with the cutting height set too low may prevent adequate air movement under the deck. This will cause clogging of the catching system.
- During peak growing times it may be necessary to cut the grass more often. If the grass is too long it may need to be cut twice. First, mow the grass with the cutting height set at a high setting to cut off the upper parts of the grass. Next, lower the cutting height to the preferred finished cut height and mow the area again. This will help reduce clogging.
- To help reduce clogging mow by slightly overlapping the previously cut area.
- Proceed to mow in the normal manner with the engine throttle set to the "FAST" position. Control the mower's ground speed by using the steering control levers. In tall and/or wet grass the high engine speed and slower ground speed will help prevent clogging.
- When catching on slopes mow going downhill when possible. It is necessary to reduce ground speed when operating on a slope.

- If debris begins to blow out in front of the outlet tube or a trail of debris is visible along the right edge of the cutting path, either the catcher is full or the outlet tube is clogged.
- As you mow visually check how full the bags are, when the right bag looks full move the deck clutch switch to the disengaged position and drive the machine to the unloading area.
- It is best that the bags be unloaded before the discharge chute and tube areas become clogged. If clogging occurs, it will be necessary to clean the discharge chute and tube areas of all material before starting to mow again.
- When the grass is wet it may be necessary to mow it first in the side discharge mode. Then, after the clippings have dried, go back over the area with the catcher installed and pickup the clippings.
- To minimize clogging, reduce your mowing speed as necessary or wait until there is less moisture in the grass.



WARNING



Remember, as the bags fill more weight is added to the back of the mower. Any rapid movement of the control levers in either direction could result in a reaction of the mower that can cause serious injury.

- Do not stop or start suddenly when mowing on slopes. Avoid uphill starts.
- Disengage the blades if you stop the mower when going uphill and proceed to back off the slope slowly.
- Maintain an even mowing speed when operating on slopes.
- Do not stop on a slope.



WARNING



Make certain the engine is turned off, the steering control levers are in the park brake position and the ignition key is removed from the ignition switch. Be sure blades have stopped before cleaning the discharge chute and transfer tube areas.



WARNING



Never place hands or feet into the discharge area. The mower blade is relatively close to the housing and will cause severe injury. Use a probe to clean debris from the catcher outlet tube.



WARNING



Never engage the mower deck unless the catcher transfer tube is secured in place, with the elastic strap, on the outlet tube and is inserted into the catcher lid. Figure 4-1

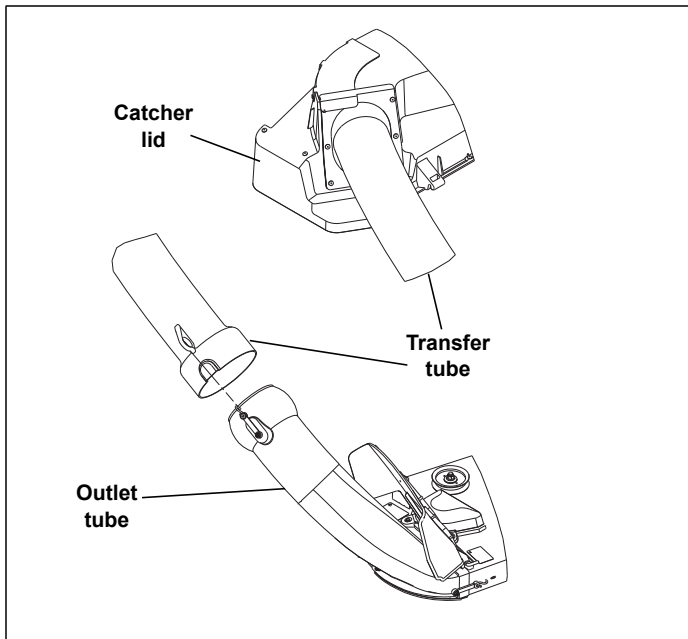

Figure 4-1

Unloading the Catcher Bags

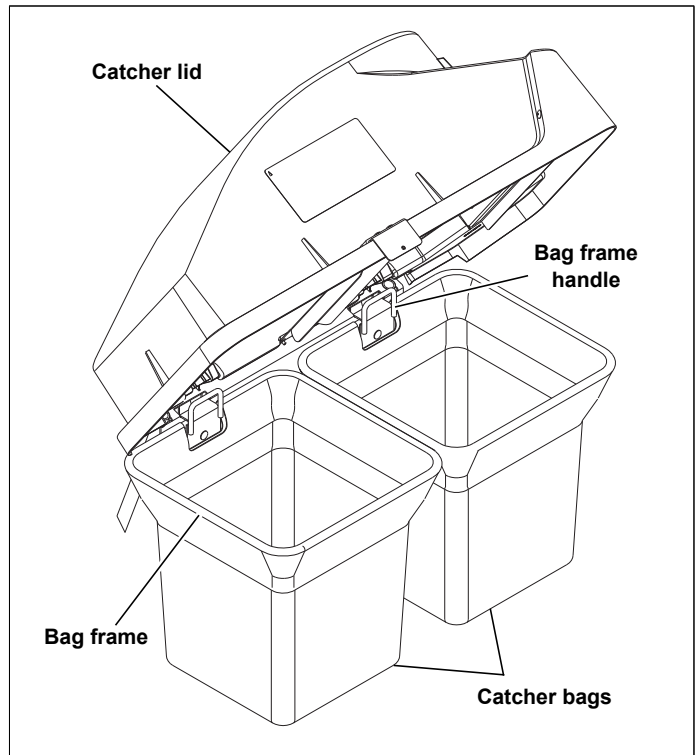

Figure 4-2

WARNING

Park the unit on a level surface, disengage the deck clutch switch, place the steering control levers in the park brake position and shut the engine off. Make certain the deck clutch switch is in the disengaged position before unloading.

Get off the mower. Unlatch and raise the catcher lid. Remove the bag by lifting the bag frame at the rear of the bag and the bag frame handle. Proceed to dump the bag. Figure 4-2

Return the bags to the catcher frame and close the catcher lid. Secure the lid using the elastic strap. Figure 4-2

Transporting Mower With Catcher

When transporting the mower, with the catcher attached, to another location on an open trailer or vehicle, the catcher lid, bags, and tubes must be removed and secured in the transporting vehicle to prevent them from being blown off.

Converting To Side Discharge Mode

Convert the mower back to the side discharge mode when catching is not desired.

When converting to side discharge mode it will be necessary to remove the bags, tubes, and catcher lid from the mower. The catcher frame can remain in place on the mower.

When converting to the side discharge mode it is necessary to remove the right hand (catching) blade from the mower. Replace

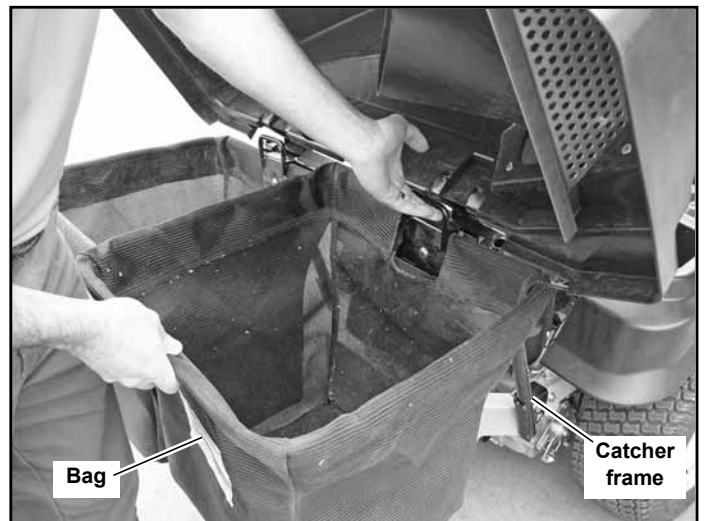

Figure 4-3

it with the proper side discharge blade. **Torque blade bolt to 48 ft.-lbs. (65 N-m).**

IMPORTANT: Only use a torque wrench when tightening and torquing the blade bolts.

WARNING

Failure to correctly torque the bolt may result in the loss of the blade which can cause serious injury.

IMPORTANT: Make certain the discharge chute is lowered to the mowing position before mowing.



WARNING



Always operate with complete catcher system, mulching system or side discharge chute in place and in the lowest position.

MAINTENANCE & STORAGE

Maintenance



WARNING



Never work on the mower deck when the engine is running.



WARNING



Clean flammable material from machine. Prevent fires by keeping the engine compartment, top of deck, exhaust area, battery, fuel line, fuel tank and operator's station clean of accumulated trash, grass clippings, and other debris. Always clean up spilled fuel and oil.

Inspect the catcher after the initial use of the unit and every month thereafter.

- Check for damaged or worn parts. Replace or repair all damaged parts before operating with the catcher again.
- Check for loose hardware. Tighten any hardware that is loose.
- Inspect the tie straps and replace any that are missing, damaged or beginning to show signs of wear.
- Inspect and replace the bags if any deterioration has occurred.



WARNING



Severe injury can occur to the operator and/or bystanders or property damage may occur as the result of flying debris or thrown objects due to damaged bags.

- Check bags for any signs of damage such as tears, holes, wear or any deterioration.
- If a bag is found to be defective in any way, replace it with a new bag that is supplied by Excel Industries, Inc.

The outlet tube and transfer tube should be kept clean and free of any accumulation of matted clippings or other obstructions.



WARNING



Prevent objects being thrown and the accumulation of grass clippings and other debris in engine compartment by NEVER operating the mower deck unless:

- Both bags are installed.
- Catcher lid is lowered.
- Outlet tube is in place and secured on the discharge chute outlet and deck. Figure 5-1
- Transfer tube is secured in place, with the elastic strap, on the outlet tube and is inserted into the catcher lid. Figure 5-1

To service the outlet tube and transfer tube, remove the tubes from the unit. The tubes can be cleaned by using soapy water and washing the inside of the tubes with a pressure washer. Rinse with water.

To clean the bags, hand wash with soap and water; rinse with clean water.

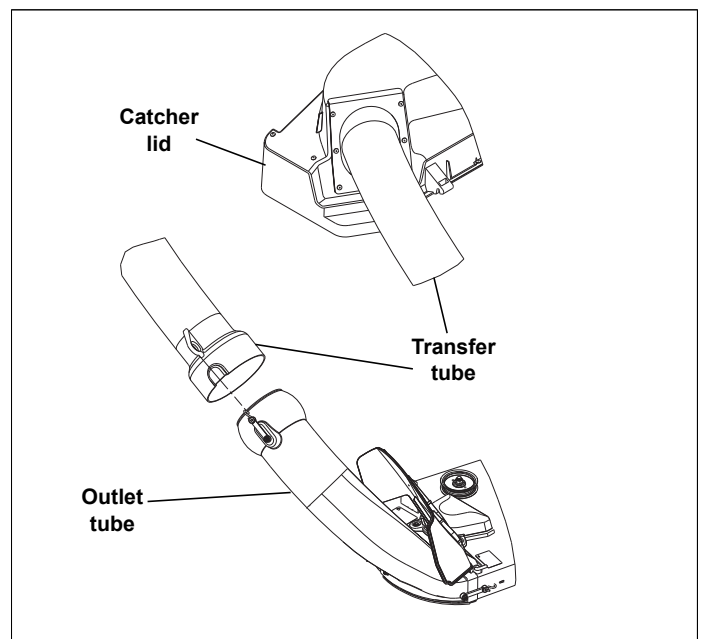

Figure 5-1

Storage

When your mower is to set idle for a period of time, scrape and remove the matted grass material from inside the hood and clean the bags.

Check for loose or missing hardware, tighten or replace. Also check for badly worn or damaged parts, consider replacing them at this time. Touch up chipped paint areas, your dealer has aerosol spray paint available.

EXCEL

INDUSTRIES

Two Bag Catcher Warranty Policy

Excel Industries, Inc. makes the following warranty to the **original purchaser** only:

- a. Excel Industries, Inc. Attachments and Accessories are warranted for **one (1) year (parts and labor) from date of delivery** on all materials and workmanship.

If the Purchaser discovers within this warranty period a defect in materials or workmanship:

- He must promptly notify an authorized Excel Industries, Inc. dealer of the defect. In no event

shall such notification be received by an authorized Excel Industries, Inc. dealer later than **thirteen (13) months** from date of delivery.

- Within a reasonable time after such notification, Excel Industries, Inc. will correct any defect in material or workmanship on the Excel Industries, Inc. turf equipment, by repairing or replacing part(s) with either new or used replacement parts.
- Such repair, including parts and labor shall be at the expense of Excel Industries, Inc., and,

General Information

Who Must Perform The Warranty Service

All warranty service will be performed by dealers authorized by Excel Industries, Inc.. **Service calls and/or transportation expense** of the product to and from the authorized dealer, for warranty work, will be paid by the owner of the product. For warranty service contact an authorized dealer.

What Is Not Covered By This Warranty

Excel Industries, Inc. does not warranty:

- Repairs made by unauthorized persons.
- Damage caused by use of the Excel Industries, Inc. turf equipment for purposes other than those for which it was designed.
- Damages caused by disasters such as fire, flood, wind, and lightning.
- Damages caused by neglect, abuse, abnormal use, improper or unreasonable use, accident, negligence or misuse.
- Repairs or replacement resulting from the use of unauthorized parts, accessories or attachments.
- Damage caused by foam filled or solid filled tires.
- Repairs or replacement as the result of alterations or modifications.
- Excel Industries, Inc. turf equipment which has the serial number removed or made illegible.
- Depreciation or damage caused by normal wear, lack of reasonable and proper maintenance, failure to follow the product's operator's manual operating, maintenance and adjustment instructions or other operational instructions provided by Excel Industries, Inc.
- Normal maintenance parts and service including, but not limited to, lubricants, belts, blades, blade sharpening, or bearings.

Disclaimer Of Warranty

The foregoing warranties are in lieu of all other warranties, expressed or implied, including but not limited to the implied warranties of merchantability and fitness for a particular purpose. However, if the Excel Industries, Inc. turf equipment is purchased as a consumer product, any implied warranty of merchantability or fitness for a particular purpose is limited to the duration of this limited warranty. Some states do not allow limitations on how long an implied warranty lasts, so the above limitation may not apply to you. This warranty gives you specific legal rights, and you may also have other rights which vary from state to state.

Limitations Of Warranties

In no case shall Excel Industries, Inc., be liable for any special, incidental, or consequential damages based upon breach of warranty, breach of contract, negligence, strict liability in tort, or any other legal theory.

Such damages include, but are not limited to:

- Loss of profits
- Loss of savings or revenue
- Loss of use of Excel Industries, Inc. turf equipment or any associated equipment
- Cost of capital
- Cost of any substitute equipment, facilities, services or downtime
- The claims of third parties including customers, and injury to property

Some states do not allow the exclusion or limitation of incidental or consequential damages, so the above limitation or exclusion may not apply to you.

No Other Warranties

Unless modified in writing, signed by both parties, and approved by the President of Excel Industries, Inc., this agreement is understood to be the complete and exclusive agreement between the parties, superseding all prior

agreements, oral or written, and all other communications between the parties relating to the subject matter of this agreement. No employee of Excel Industries, Inc., or any other party is authorized to make any warranty in addition to those made in this agreement.

Allocation Of Risks

This agreement allocates the risks of product failure between Excel Industries, Inc. and the purchaser. This allocation is recognized by both parties and is reflected in the price of the goods.

Owner's Responsibility

You must maintain your Excel Industries, Inc. Product following the maintenance procedures described in your operator's manual. Such routine maintenance, whether performed by a dealer or by you, is at your expense.

This machine like any other powered equipment is potentially dangerous unless properly operated. Any operator **must** be cautious and keep safety in mind at all times. Any operator, prior to using the Excel Industries, Inc. turf equipment, should thoroughly familiarize himself with the operator's manual regarding operation and safety of the machine, as well as all safety warnings on the machine itself.

Warranty Registration

- **Excel Industries, Inc. Dealers must** register the unit on-line at <https://excel.warrantysmart.ari-net.com> within **ten (10) days** following date of purchase.

Parts Manual

Catcher Frame	7-2
Catcher Lid—552396	7-4
Catcher Chutes & Blades	7-6
Catcher Bag Assembly—552460	7-8

Catcher Frame

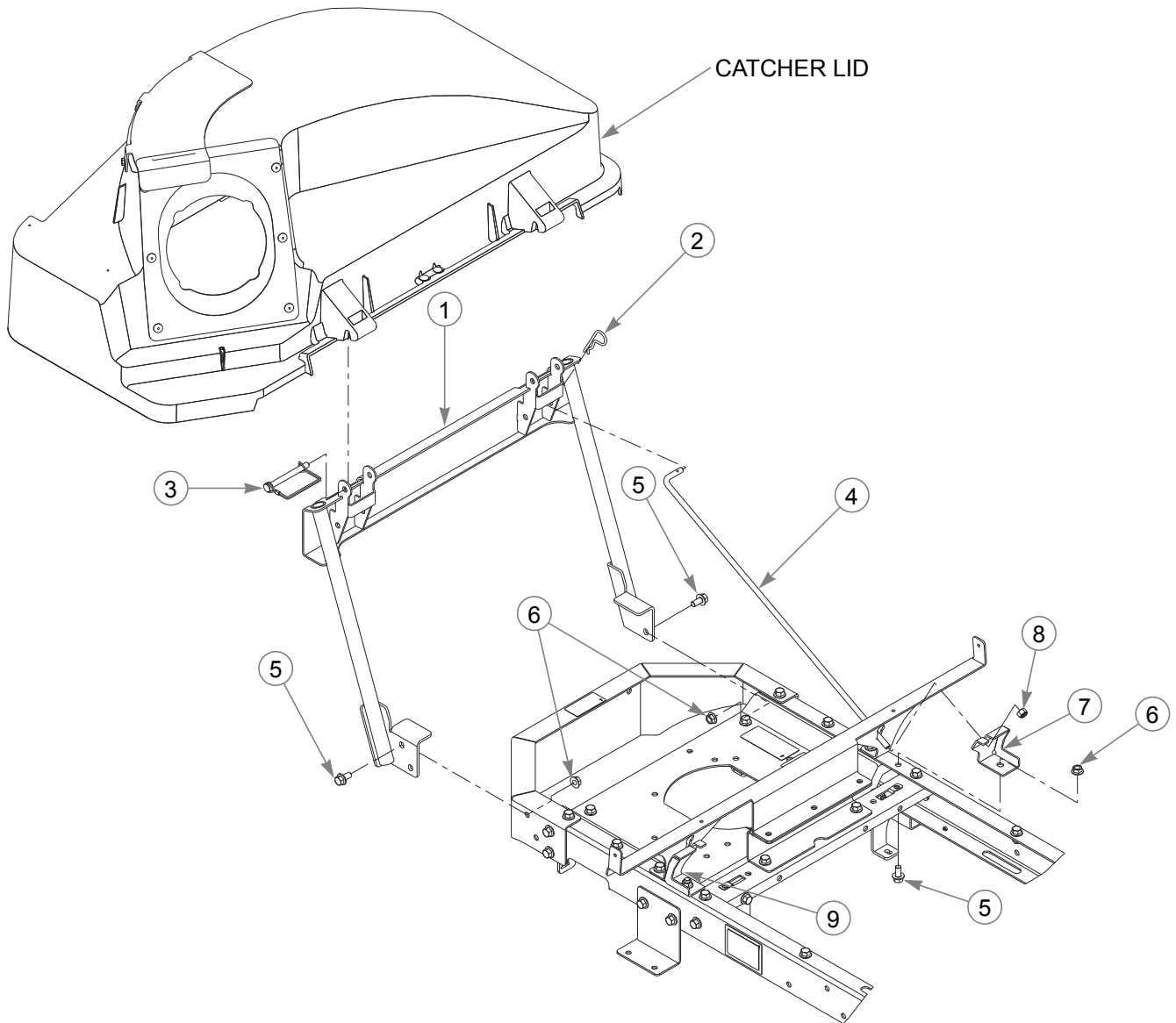

Catcher Frame

INDEX NO.	PART NO.	QTY.	DESCRIPTION
1	117394	1	CATCHER FRAME
2	023036	2	HP .148 X 2.69 ZN
3	604887	2	CE .375 X 3.00 WITH BALE
4	604301	2	TIE ROD
5	029629	8	CS .375-16 X .75 HX FLK
6	016899	8	NT .375-16 HX FLK ZNYC
7	117303	1	LS SUPPORT GUSSET
8	086660	2	NT .375-16 NL G5
9	117304	1	RS SUPPORT GUSSET (NOT EXPLODED)

NOTES:

Catcher Lid—552396

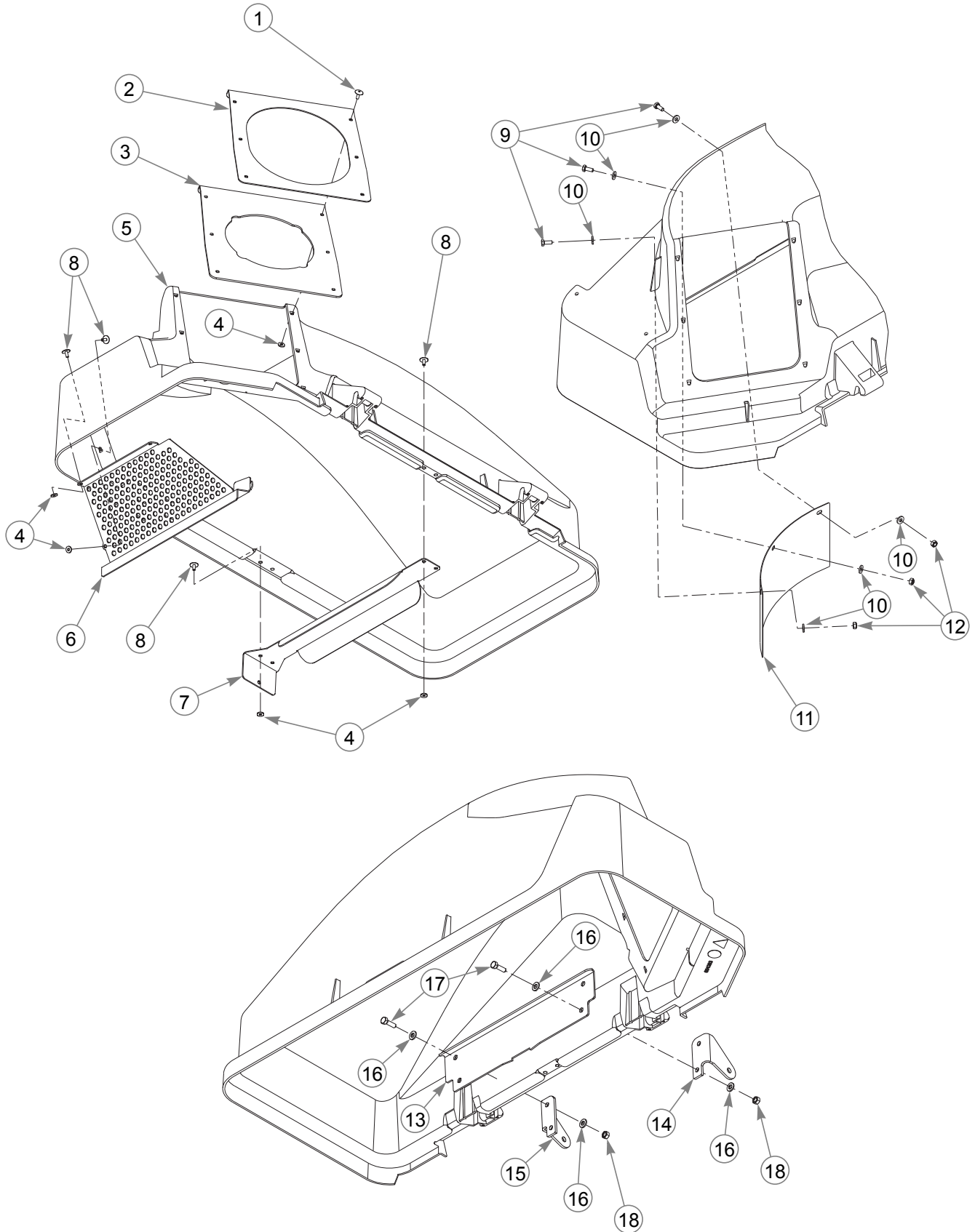

Catcher Lid—552396

INDEX NO.	PART NO.	QTY.	DESCRIPTION
1	603398	6	RIVET
2	117501	1	CATCHER INLET
3	604394	1	INLET SEAL
4	603400	13	FW .188 X .50 X .060
5	552396	1	CATCHER LID (COMPLETE ASSEMBLY)
6	117678	1	VENT MOUNT BRACKET
7	117584	1	BAG DIVIDER
8	604805	7	BLIND RIVET
9	064329	3	CS .250-20 X .625 HX G5
10	768515	6	FW .281 X .625 X .051/.080 HD ZN/YL
11	118562	1	DEBRIS GUIDE
12	068551	3	NT .250-20 HX ZY NL
13	120884	1	STIFFENER PLATE
14	120882	1	HINGE BRACKET RS
15	120883	1	HINGE BRACKET LS
16	768523	8	FW .343 X .687 X .051/.080H
17	036236	4	CS .312-18 X 1.00 HX G5
18	034272	4	NT .312-18 HX G5 ZNYC

NOTES:

Catcher Chutes & Blades

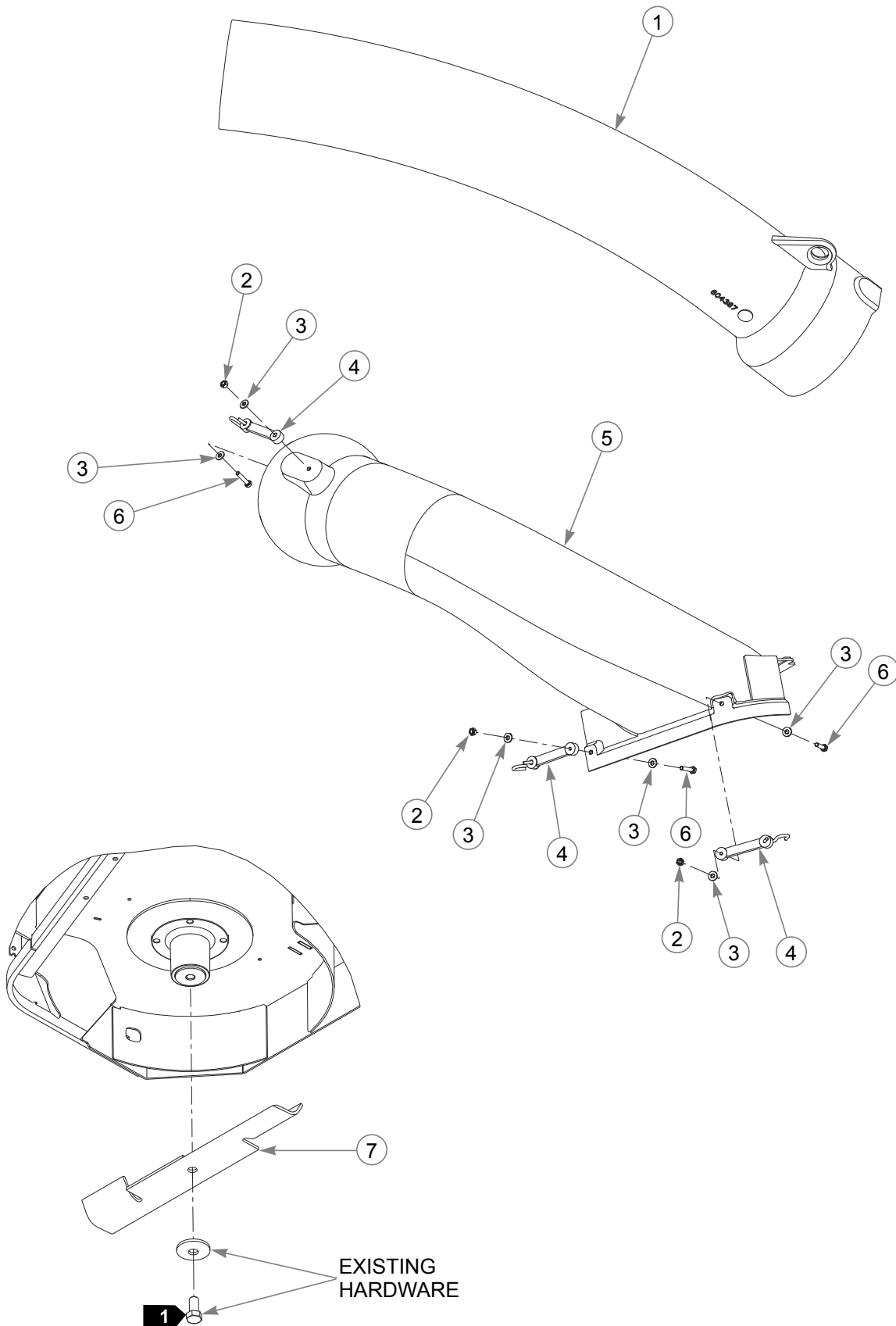

Catcher Chutes & Blades

INDEX NO.	PART NO.	QTY.	DESCRIPTION
1	604387	1	UPPER CHUTE
2	068551	3	NT .250-20 HX ZY NL
3	768515	6	FW .281 X .625 X .051/.080H
4	604475	3	BUNGEE LATCH
5	604815	1	CATCHER CHUTE
6	704916	3	CS .250-20 X 1.25 HX G5
7	796649	1	BLADE, 16.50"-CAT-F-CW (48" DECK)
8	602416	1	BLADE, 18.50"-CAT-F-CW (54" DECK NOT SHOWN)
9	793935	1	BLADE, 20.50"-CAT-F-CW (60" DECK NOT SHOWN)

NOTES:

1. Torque to 118 ft-lbs (160 N-m).

Catcher Bag Assembly—552460

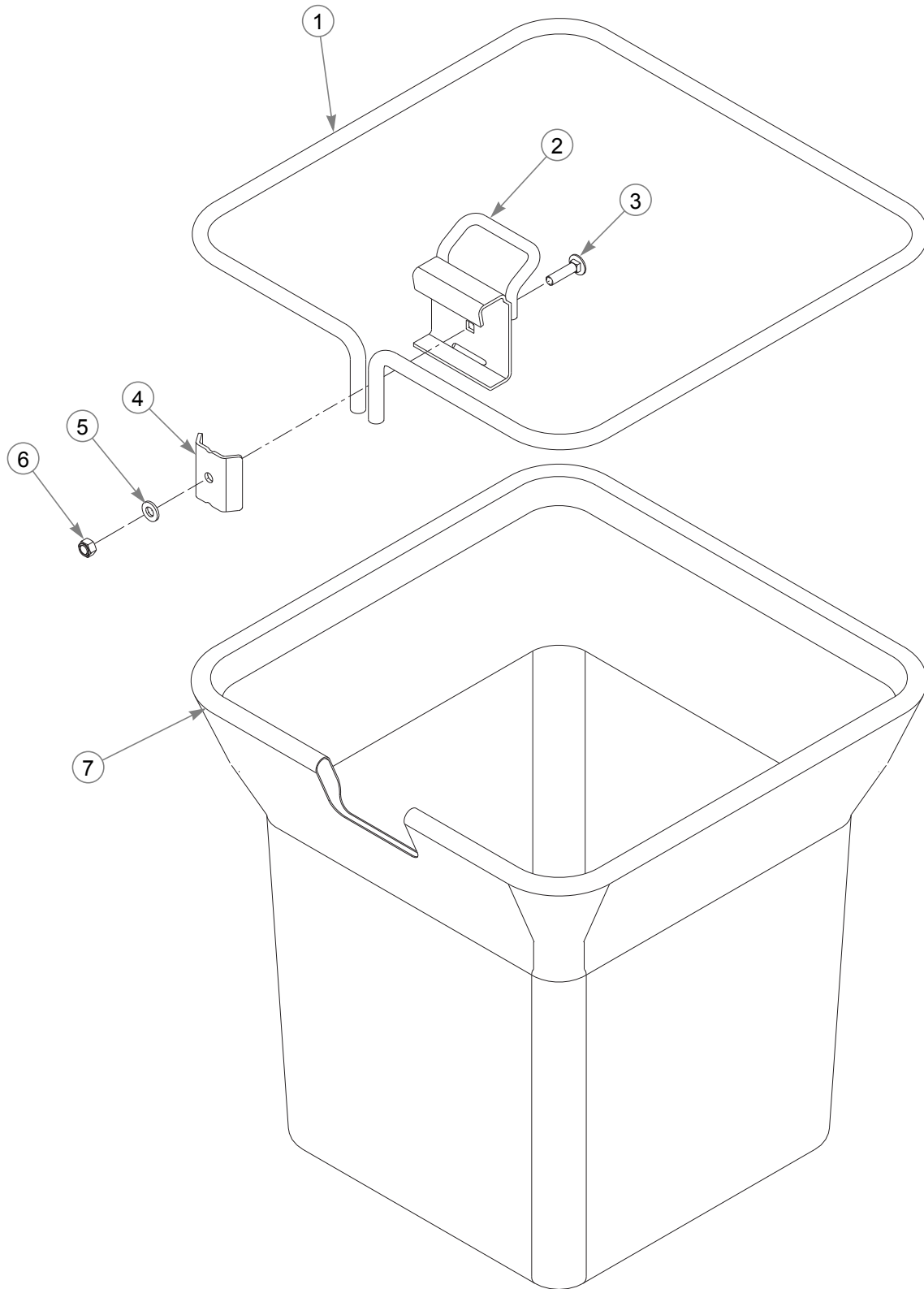

Catcher Bag Assembly—552460

INDEX NO.	PART NO.	QTY.	DESCRIPTION
1	117393	1	BAG SUPPORT
2	117390	1	BAG CATCH
3	602827	1	CB .312-18 X 1.25 ZNYC
4	117401	1	CLAMP BRACKET
5	768523	1	FW .343 X .687 X .051/.080H
6	058776	1	NT .312-18 HX ZY NL
7	552460	1	CATCHER BAG ASSEMBLY (BAG INCL. ITEMS 1-6)

NOTES:

INDEX

	PAGE		PAGE
Assembly	3-1	Safety and Instruction Decals	2-1
Converting To Side Discharge Mode	4-2	Storage	5-1
Maintenance	5-1	To the New Owner	1-1
Parts and Service	1-1	Transporting Mower With Catcher Attached	4-2
Parts List	3-1	Unloading the Catcher Bags	4-2
Required Tools	3-1	Vacuum Pickup and Collection	4-1
Safe Operation and Service Precautions	2-1	Warranty registration	1-1

