



Range of California, Inc.

Item: _____

Quantity: _____

Project: _____

Radiant Broiler

Radiant Broiler

Models:	<input type="checkbox"/> RRB-12	<input type="checkbox"/> RRB-18	<input type="checkbox"/> RRB-24	<input type="checkbox"/> RRB-30
	<input type="checkbox"/> RRB-36	<input type="checkbox"/> RRB-48	<input type="checkbox"/> RRB-60	<input type="checkbox"/> RRB-72



Gas Type: Natural LP

Elevation (if above 2000 ft.): _____

Options and Accessories

- Fish grate
- Diamond grate
- Stainless steel splash guard, up to 12" high, sides tapered to 4" in front
- Add plate shelf with or without cutouts
- Stainless Steel Equipment Stand

Knock Down All Welded

Size

- 12" 18" 24" 30" 36" 48" 60" 72"
- 5" swivel casters (set of four - 2 locking)
- 5" swivel casters (set of six - 3 locking) (60" and 72" models)

Standard Features

- NEW 11" Low Profile
- NEW easily removable independent firebox assembly
- NEW full width, removable stainless steel crumb pan under the broiler for easy cleaning
- Heavy duty cast iron radiant covers
- Compact heavy gauge chassis for long life
- Stainless steel sides, front valve cover and ledge
- Double wall panels for cooler sides
- All welded fire box supports heavy duty radiant covers
- Stainless steel tubular burners rated at 15,000 BTU/hr each
- Individually adjustable burners provide powerful radiant heat
- Standing pilots for instant ignition
- Heavy duty cast iron top grates
- Stainless steel tubing for pilots
- 4" high adjustable heavy duty legs included
- One year limited warranty, parts and labor



Royal Range of California, Inc.

3245 Corridor Dr. • Eastvale, CA 91752 • (800) 769-2414 • (951) 360-1600

Fax: (951) 360-7500 • www.royalranges.com • sales@royalranges.com



Radiant Broiler

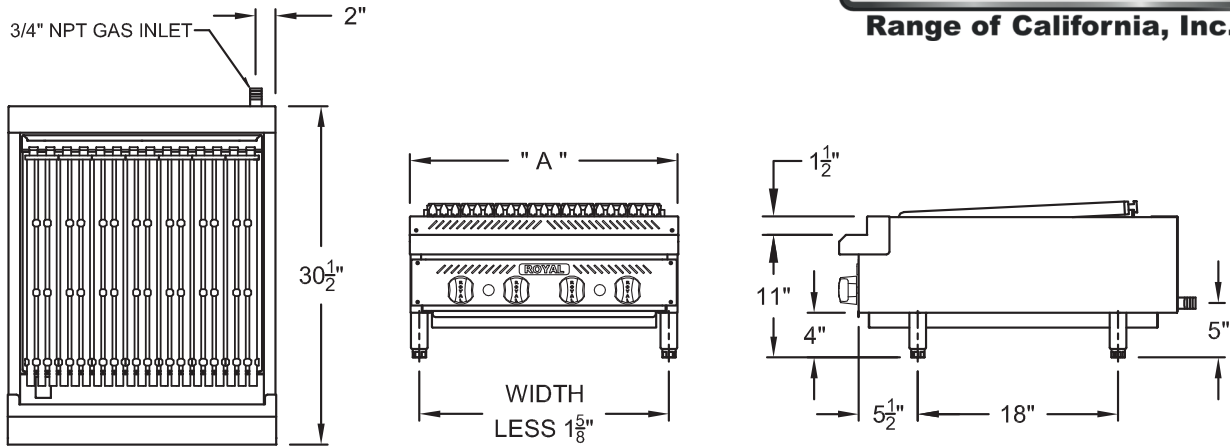

Model Number	Width (A)	Number of Burners	Total BTU	Ship Weight
RRB-12	12"	1	15,000	170 lbs.
RRB-18	18"	3	45,000	235 lbs.
RRB-24	24"	4	60,000	300 lbs.
RRB-30	30"	5	75,000	340 lbs.
RRB-36	36"	6	90,000	383 lbs.
RRB-48	48"	8	120,000	460 lbs.
RRB-60	60"	10	150,000	510 lbs.
RRB-72	72"	12	180,000	670 lbs.

Notes:

- Radiant burners at 15,000 BTU/hr each

Gas Connection:

3/4" NPT on the right hand rear of the appliance.
The pressure regulator (supplied) is to be connected by the installer.

Gas Pressure:

5" W.C.	Natural Gas
10" W.C.	Propane

Clearances: For installation in non-combustible locations only

	Combustible	Non-Combustible
Rear	N/A	0"
Sides	N/A	0"

Specify type of gas and altitude, if over 2,000 feet, when ordering.

Due to continuing product development to ensure best possible performance, these specifications are subject to change without prior notification.