



- TASTE THE DIFFERENCE -

## MODEL CS600

This high-volume, single-flavor counter model soft serve freezer is easy to operate and simple to clean. The CS600 provides menu flexibility for convenience stores, specialty buffets, airport kiosks, burger restaurants, diners and ice cream stores.

### The Electro Freeze Advantage

- **The Finest Frozen Product**, consistently the best frozen product available. Smooth, creamy and profitable
- **Exclusive Auger Design** gently blends, reducing agitation and maintaining product quality and consistency
- **Consistency Control** designed to dispense the finest frozen product available
- **Air Filter** washable filter keeps the condenser clean
- **Compact** with small footprint
- **Experience Tells** Electro Freeze has been manufacturing quality frozen treat machines since 1929. Superior engineering, product innovations, sturdy construction, quality craftsmanship and dependable performance are Electro Freeze hallmarks.
- **Superior Service Support** backed by a world-wide distributor network

### Optional

- **Top Air Discharge Chute** the top air discharge chute on air cooled models allows units to be set side by side and air flow to be diverted up.
- **Cabinet** an optional commercial grade stainless steel cabinet is available includes heavy duty casters, a sturdy latch and gives you 6 cubic feet of storage.

## GRAVITY SOFT SERVE FREEZER

### Compact Series Single Flavor



*Shown with Optional Cabinet*

[electrofreeze.com](http://electrofreeze.com)

FOR MORE INFORMATION CONTACT

800-755-4545 • [sales@electrofreeze.com](mailto:sales@electrofreeze.com)

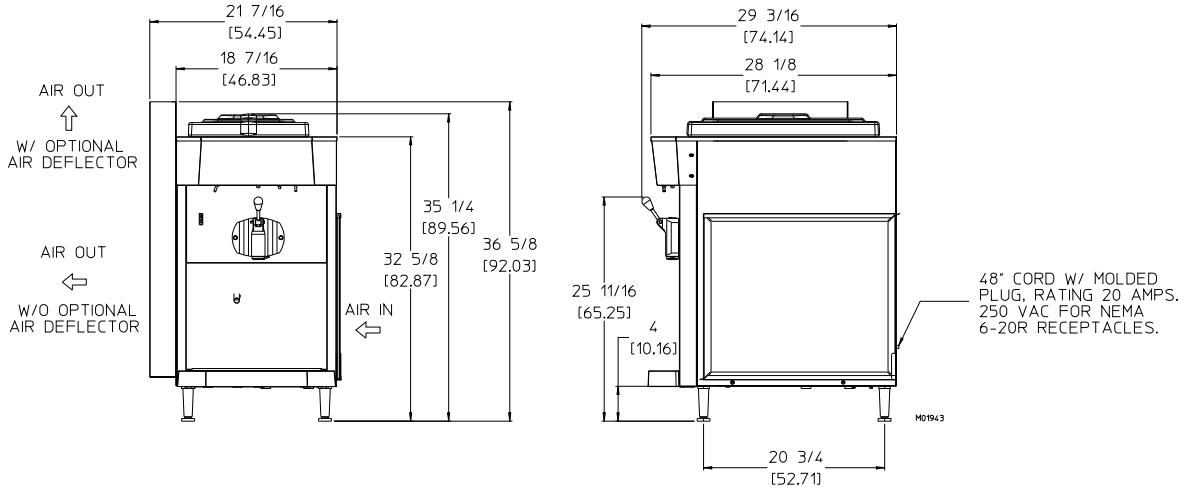

### MODEL CS600 SPECIFICATIONS

Due to continual product improvements all specifications are subject to change without notice.

Weights	lbs.	kgs.
Net	294	134
Crated	390	177
	cu.ft.	cu.m.
Volume	39.5	1.2
Dimensions*	in.	cm.
Width	18-7/16	46.83
Depth	28-1/8	71.44
Height	35-1/4	89.56

\* without optional air deflector

Electrical	Total Amps	NEMA Plug Type	Poles (P) Wires (W)
208-230/60/1 Air	15.0	6-20P	n/a
208-230/60/1 Water	14.0	6-20P	n/a
220-240/50/1 Air	14.7	n/a	2P (2W)
220-240/50/1 Water	13.8	n/a	2P (2W)

Electrical characteristics other than above available on request from factory or local distributor. Check nameplate for exact electrical data.

#### Bidding Spec

Electrical: Volt \_\_\_\_\_ Hz \_\_\_\_\_ Ph \_\_\_\_\_  
 Cooling: \_\_\_\_\_ Neutral \_\_\_\_\_ Yes \_\_\_\_\_ No  
 Options: \_\_\_\_\_

#### Electrical

One dedicated electrical connection is required. 60 Hertz units connect to a standard NEMA 6-20R receptacle. See electrical chart for the proper requirement. Consult your local electrical codes for receptacle specifications.

#### Beater Motor

One, 1.5 hp.

#### Refrigeration Systems

One, 9,500 Btuh. R404a.  
 Btuh may vary depending on compressor used.

#### Air and Water Cooled

3" (7.6 cm) air space required on sides and behind rear panel for proper air circulation

Mix Hopper Capacity: one - 20 quarts (18.8 liters)

Freezing Cylinder Capacity: one - 3.7 quarts (3.5 liters)

Certified and/or listed by:



\*UL listed and listed by Underwriters Laboratories under Canadian National Standard C22.2 No. 120-M91 (R2008)  
 \*\*Select Voltages @ 50HZ



**Electro Freeze div. of H.C. Duke & Son, LLC**  
 2116-8th Avenue, East Moline, Illinois 61244 USA  
 Phone (309) 755-4553 • (800) 755-4545  
 FAX (309) 755-9858  
 E-mail: sales@electrofreeze.com • www.electrofreeze.com

**Authorized Distributor**