

<b>JOB:</b>	<b>REPRESENTATIVE:</b>	
<b>UNIT TAG:</b>	<b>ORDER NO.</b>	<b>DATE:</b>
<b>ENGINEER:</b>	<b>SUBMITTED BY:</b>	<b>DATE:</b>
<b>CONTRACTOR:</b>	<b>APPROVED BY:</b>	<b>DATE:</b>

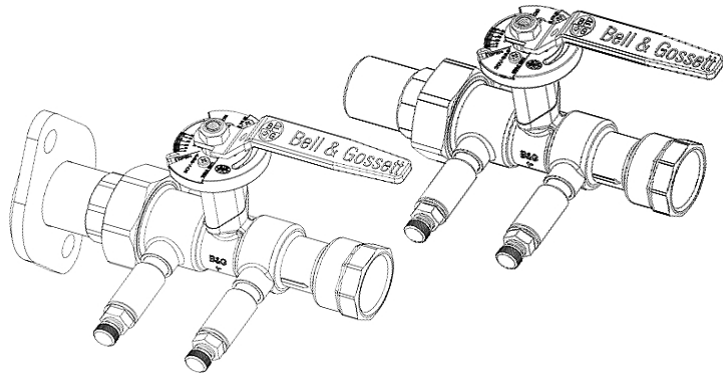

Centrifugal Pump Accessories

# Triple Duty Valve

## Model 3DV

Combination balance, check and shut-off valve

**DESCRIPTION**

The Bell & Gossett Triple Duty Valve Model 3DV is a combination shut-off, check, and balance valve for use in HVAC systems. The full port ball valve provides complete shut-off to allow your pump to be removed without draining the system. The spring loaded check prevents gravity circulation and backflow in systems utilizing zoned or parallel pumping, while allowing the valve to be rotated in any direction. The calibrated nameplate with memory stop provides basic balance capabilities for your entire system. The valve features a FNPT fixed outlet connection and a choice of rotatable flange union tailpiece or MNPT union tailpiece inlet connection. The valve also features an extended handle design as well as two extended 1/4" PT valves for insulated systems.

**CONSTRUCTION**

**Valve**

Body: C37700 Brass  
 Ball: Chrome Plated C36000 Brass  
 Seating Rings: Glass & Carbon filled PTFE  
 PT Valves: C37700 Brass w/ EPDM Seals  
 Stem: C37700 Brass

**Check valve**

Body: Glass Filled Noryl  
 Seals: EPDM  
 Spring: Stainless Steel

**MAXIMUM OPERATING PRESSURE**

200 psig (1,378 kPa)

**TEMPERATURE RANGE**

-4°F (-20°C) to 250°F (120°C)

**ACCURACY**

+/-5% (When installed w/ recommended pipe lengths\*)  
 +/-10% (When installed directly at pump discharge)

\*See IOM V1000188 for recommended pipe lengths.

**SCHEDULE**

MODEL NUMBER	TAGGING INFORMATION	QUANTITY
3DV-1NMF		
3DV-1RFF		
3DV-1-1/4NMF		
3DV-1-1/4RFF		
3DV-1-1/2NMF		
3DV-1-1/2RFF		
3DV-2NMF		
3DV-2RFF		

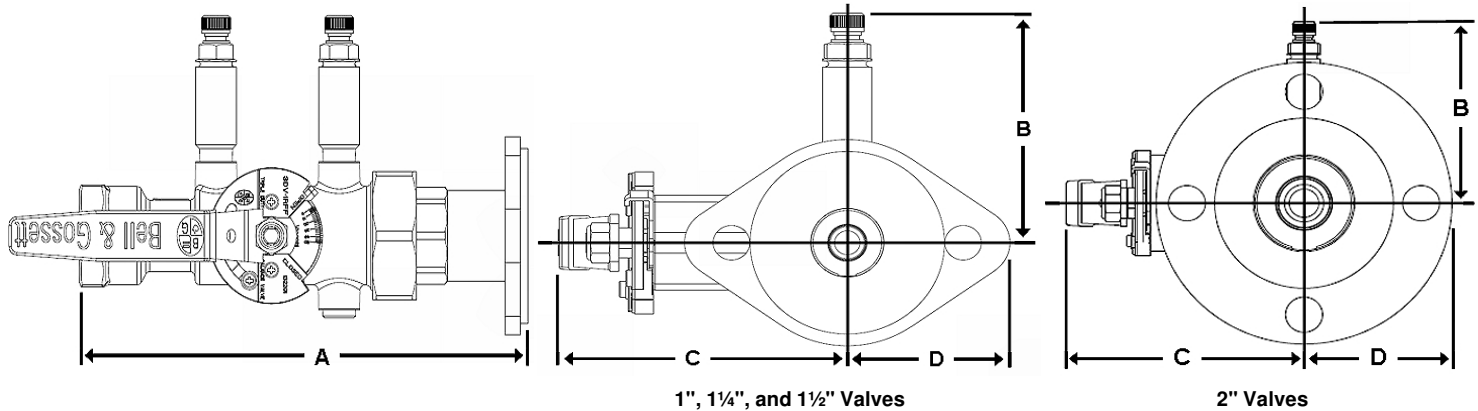

**DIMENSIONS AND WEIGHTS**

Model Number	Size	Inlet Connection Type	DIMENSIONS* IN INCHES (mm)				Cv	Approx. Weight lbs. (kg)
			A	B	C	D		
3DV-1NMF	1"	NPT Male	7.22 (183.4)	3.34 (84.8)	3.93 (99.8)	0.77 (19.6)	9	3.5 (1.6)
3DV-1RFF	1"	Rotatable Flange	7.34 (186.4)	3.34 (84.8)	3.93 (99.8)	2.22 (56.4)	9	3.5 (1.6)
3DV-1-1/4NMF	1-1/4"	NPT Male	8.11 (206.0)	3.48 (88.4)	4.46 (113.3)	0.90 (22.9)	14	4.6 (2.1)
3DV-1-1/4RFF	1-1/4"	Rotatable Flange	8.24 (209.3)	3.48 (88.4)	4.46 (113.3)	2.22 (56.4)	14	4.6 (2.1)
3DV-1-1/2NMF	1-1/2"	NPT Male	8.91 (226.3)	3.61 (91.7)	4.52 (114.8)	1.02 (25.9)	25	5.2 (2.4)
3DV-1-1/2RFF	1-1/2"	Rotatable Flange	9.07 (230.4)	3.61 (91.7)	4.52 (114.8)	2.22 (56.4)	25	5.2 (2.4)
3DV-2NMF	2"	NPT Male	10.53 (267.5)	3.86 (98.0)	4.82 (122.4)	1.34 (34.0)	28	8.3 (3.8)
3DV-2RFF	2"	Rotatable Flange	11.15 (283.2)	3.86 (98.0)	4.82 (122.4)	3.00 (76.2)	28	8.3 (3.8)

\*All dimensions +/- 0.125 (3.2 mm) tolerance. Dimensions are subject to change. Not to be used for construction purposes unless certified.

**TYPICAL SPECIFICATION**

Valves shall be Xylem Bell & Gossett Model No. 3DV-\_\_\_\_\_ Triple Duty Valve.

**VALVE DESIGN AND CONSTRUCTION**

All valves 1" to 2" shall be of brass body construction with glass and carbon filled PTFE seat rings. Valves shall be rated for a maximum working pressure of 200 psig (1,378 kPa) and have a temperature range of -4° F (-20° C) to 250° F (120° C). Valves to include full port balls that provide complete shut-off. Valve balls shall be of chrome plated brass construction. Valves to include calibrated name plates to assure specific valve settings and memory stop feature to allow valves to be closed for service then reopened to set point without disturbing balance position. Valve bodies to have 1/4" NPT tapped differential pressure read-out ports across valve seat area. Read-out valves to be fitted with internal EPDM inserts. A 1/4" NPT tapped drain valve port shall be provided to allow for draining the pump when isolated from the system.

Valves shall include spring loaded check valve. Check valve to be of glass filled Noryl construction with EPDM seal and stainless steel spring.

**PRE-SET BALANCE FEATURE**

Valves shall be designed to allow contractor to pre-set balance points for proportional system balance prior to system start-up in accordance with pre-set balance schedule.

**PERFORMANCE/ACCURACY**

Valve Cv rating at full open position shall be not less than \_\_\_\_\_. Valve shall be accurate within +/- 5% when installed with 5 pipe diameters of straight pipe length upstream and 2 pipe diameters of straight pipe length downstream (+/- 10% when installed directly at pump discharge).

Xylem Inc.  
8200 N. Austin Avenue  
Morton Grove, IL 60053  
Phone: (847)966-3700  
Fax: (847)965-8379  
www.bellgossett.com

