

TRU Vision

Please call us
to check availability of
parts required, if not
shown herein.

Wiper Solutions

PREMIUM BUS WIPER PARTS 2015-16

DESCRIPTION	PAGE
Heavy Duty Wiper Blades & Refills	2
Heavy Duty Pantograph Wiper Arms	3 - 4
Heavy Duty Radial Wiper Arms	4
Pantograph Wiper Systems	5
Opposing Wipe - Wiper Systems	6
230 Series Wiper Systems	7
DC Electric Wiper Motors	8 - 11
Heavy Duty SWF Style Parts	12
Tru Vision Pivots & Linkages	13
Trico Style Pivots & Linkages	14
Washer Jets	15
Washer Bottles & Pumps	16
Washer Parts & Switches	17
Wiper Specification Request	18
General Warranty Statement	19

TRU VISION PTY LTD
P.O. Box 1148
Browns Plains, Qld 4118 Australia

Ph: +61 (0) 7 3806 7822
Fax: +61 (0) 7 3806 9822

Heavy Duty Wiper Blades & Refills

PART NUMBER & LENGTH

TC800 - 32" (80cm)
 TC900 - 36" (90cm)
 TC1000 - 40" (100cm)



TO SUIT 22mm CLIP WIDTH



TO SUIT 28mm CLIP WIDTH

PART NUMBER & LENGTH

TC700 - 28" (70cm)

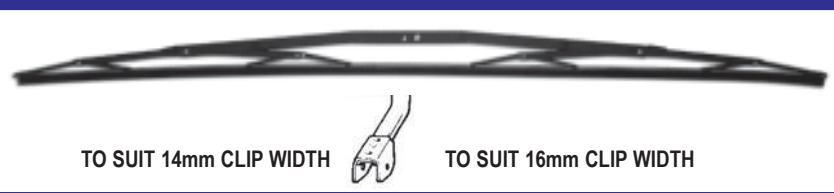

TO SUIT 14mm CLIP WIDTH



TO SUIT 16mm CLIP WIDTH

PART NUMBER & LENGTH

TVCH800 - 32" (80cm)
 TVCH900 - 36" (90cm)
 TVCH1000 - 40" (100cm)



TO SUIT 22mm CLIP WIDTH



TO SUIT 26mm CLIP WIDTH

PART NUMBER & LENGTH

TVCH900H - 36" (90cm)
 TVCH1000H - 40" (100cm)



Part No: TV1000 (Pair Pack) Part No: TV1000-10 (Box of 10)



Universal Multi-Fit Truck and Bus Wiper Blade Refills -
 40" (1000mm) are designed to fit both 8mm and 9.5mm wide wiper blades.

Part No: WRMW710 Metal Back (Pair Pack) Part No: WRMW710-10 Metal Back (Box of 10)



Wiper Blade Refills in Twin Pack or Bulk 10 Pack to suit most 8mm Wiper Blades.
 Available in either a Plastic or Metal Back.

Heavy Duty Pantograph Wiper Arms

HEAVY DUTY WIPER ARMS

Quality Heavy Duty Single and Pantograph Wiper Arms, standard with washer jets for Bus and Industrial applications.

PART No: TC777-XX (where XX = Length of arm required in cm)

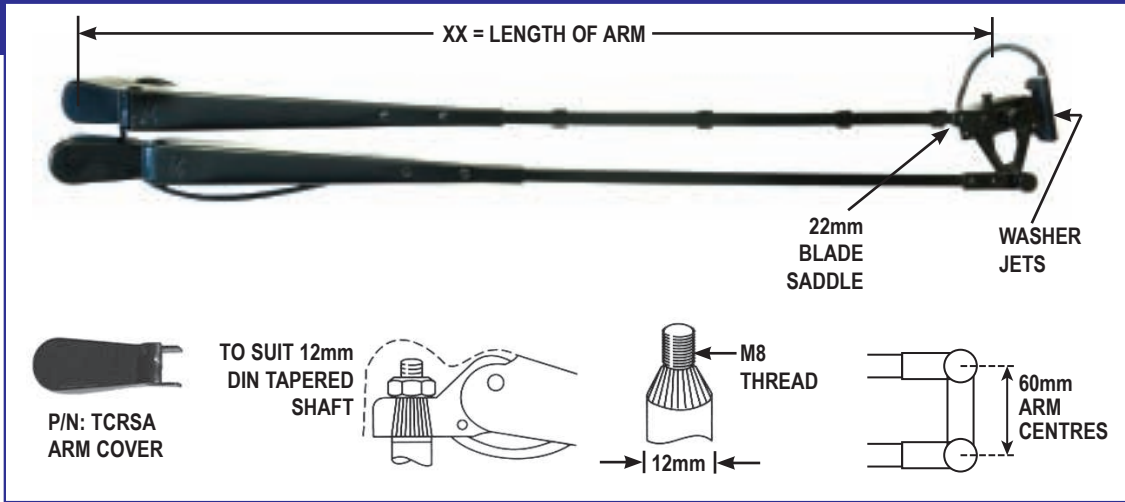

PART No: TC881-XX (where XX = Length of arm required in cm)

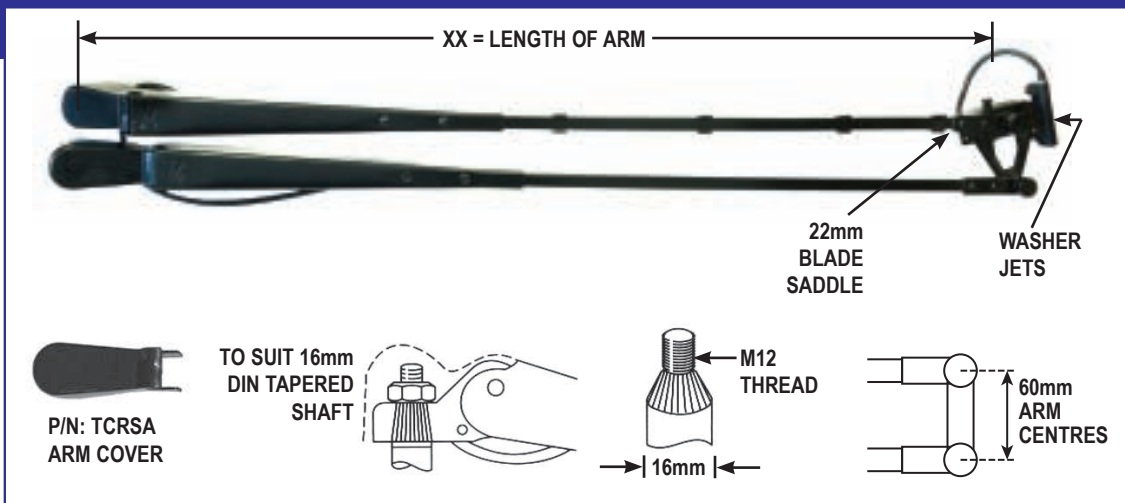

PART No: TC999-XX (where XX = Length of arm required in cm)

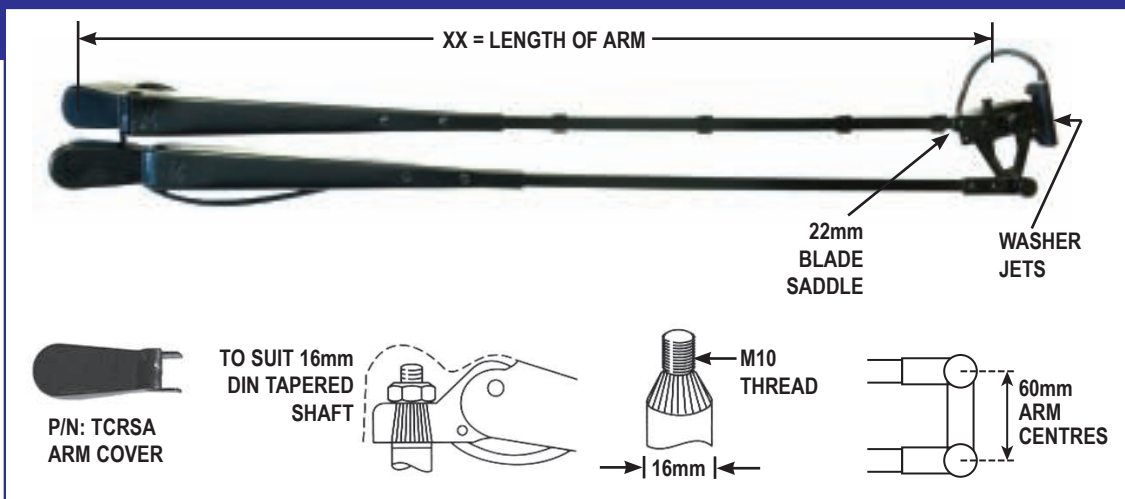

Heavy Duty Pantograph Wiper Arms

PART No: TC666-XX (where XX = Length of arm required in cm)

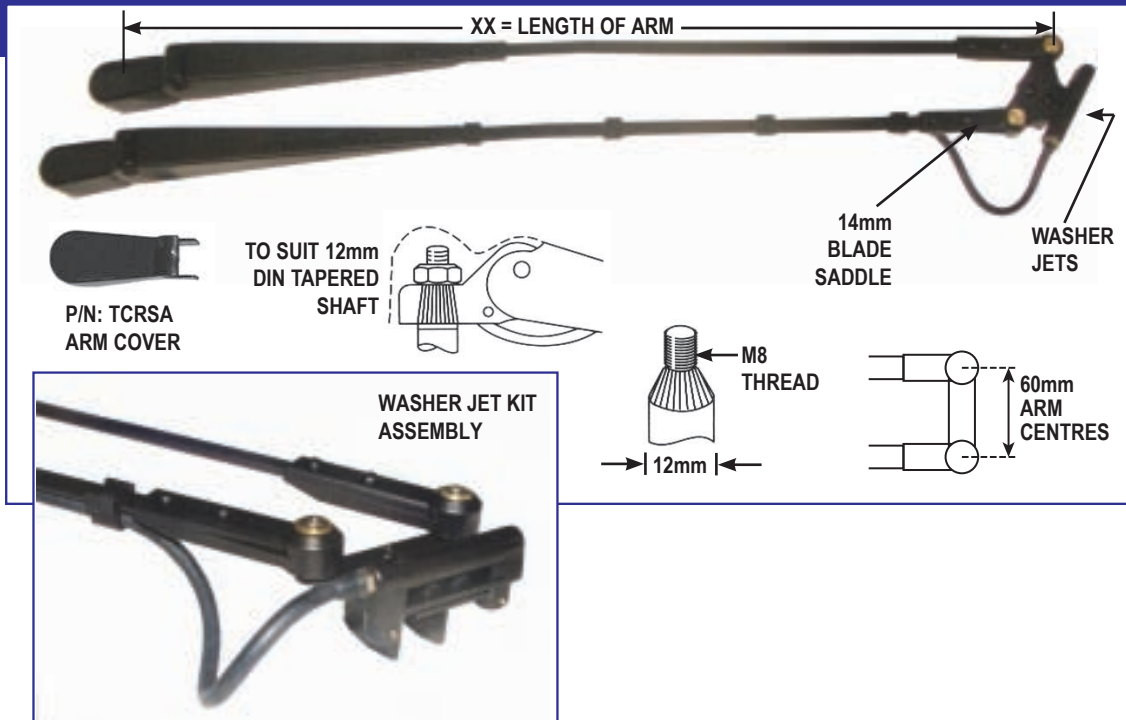

Heavy Duty Radial Wiper Arms

PART No: TCEX750-NS & TCEX751-OS (Top) and TV68996-OS & TV68994-NS (Bottom)

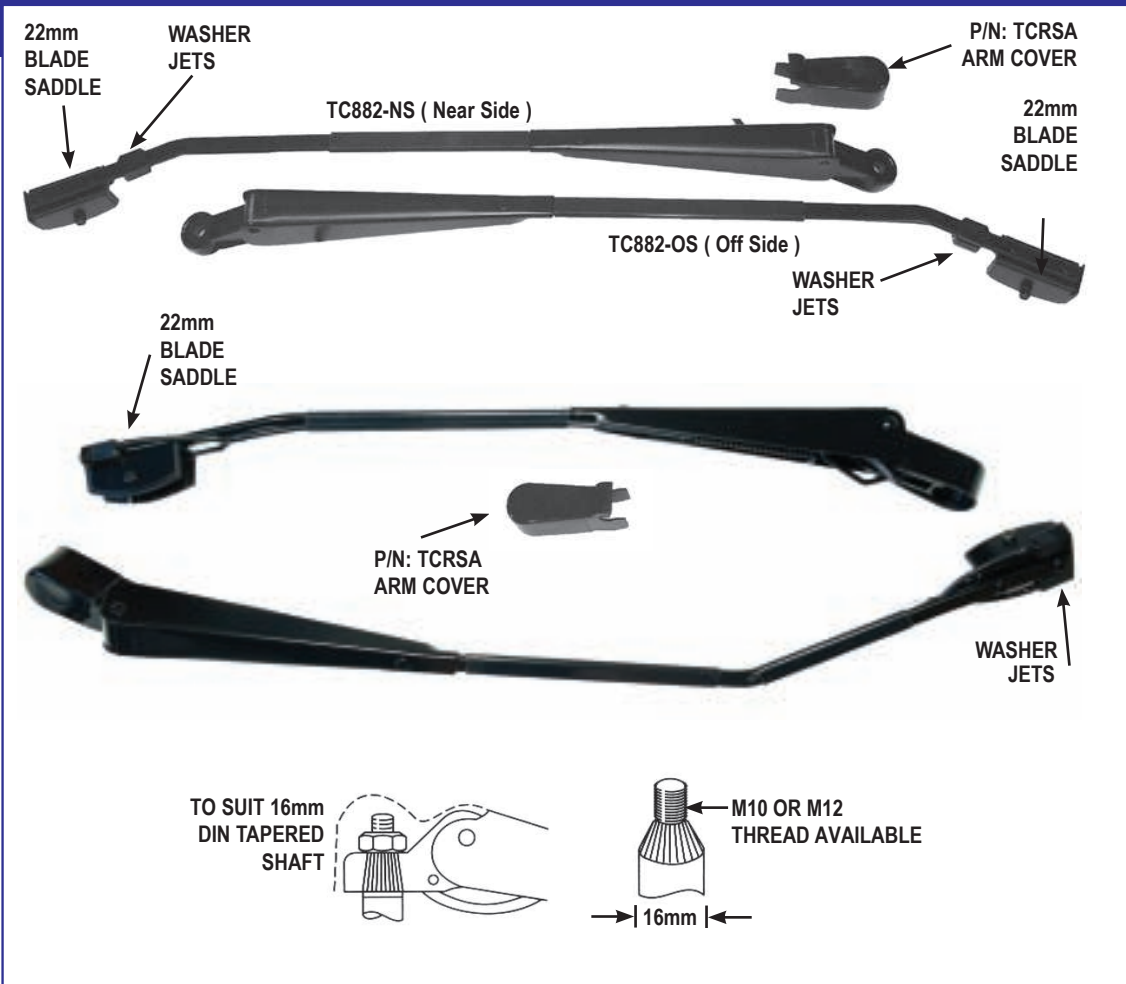

Pantograph Wiper Systems

**TRU
Vision**

HEAVY DUTY PANTOGRAPH WIPER SYSTEMS

Quality Heavy Duty Pantograph Wiper Systems designed for long life use in the Bus and Industrial Vehicle market. These wiper systems come complete with heavy duty wiper motors, arms, adjustable tubular steel linkages, heavy duty anodised pivots and wet arm washer system.

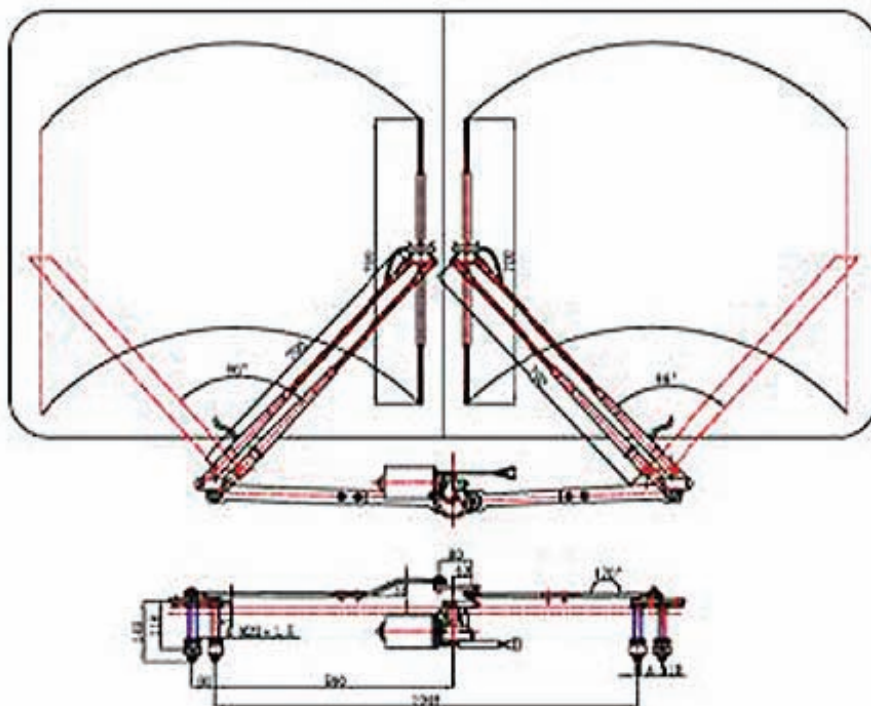

*Wiper
Solutions*

Opposing Wipe - Wiper Systems

HEAVY DUTY OPPOSING WIPE - WIPER SYSTEMS

Quality Heavy Duty 'Clap Hands' Wiper Systems designed for long life use in the Bus and Industrial Vehicle market. These wiper systems come complete with heavy duty wiper motors, arms, adjustable channel steel linkages, heavy duty anodised pivots and wet arm washer system.

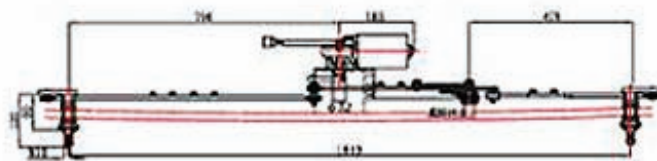
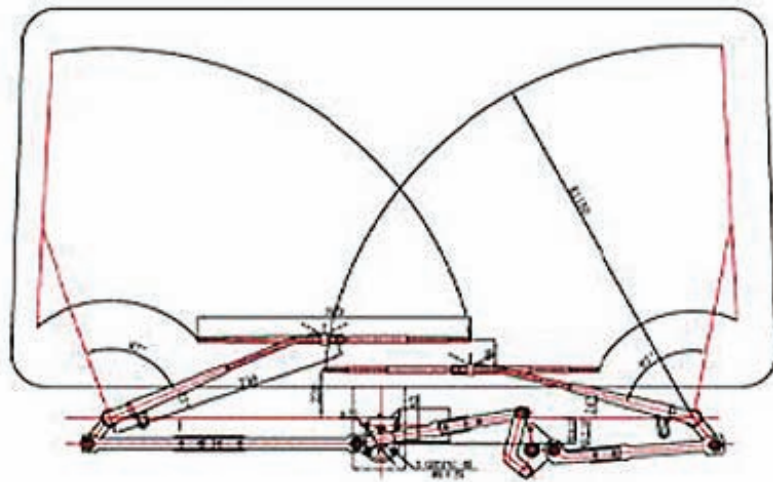

230 Series Wiper Systems

**TRU
Vision**

UNITIZED ASSEMBLY

Product Type: Right Hand 230 Series Unitized Assembly

Kit No?s:

12 Volt - 230 2013

24 Volt - 230 2012

Included in Kit -

Motor + M8 Output Shaft Nut

3 x Motor Bolts

LH Motor Bracket P/n 230J662

Link P/n 3071022

Drive Arm 26.8mm P/n 308-1057

2 Clips + washer

Make: Tru Vision

Application: Automotive and Industrial

Product Description: Wipe angles from 36 to 127 degrees

For arms and blades up to 28" (700mm)

Can be configured in radial or pantograph arms

12 and 24 volt systems available

Coast to park (dynamic parking special order)

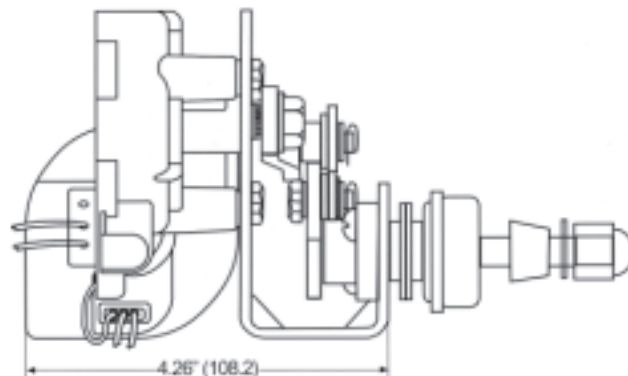
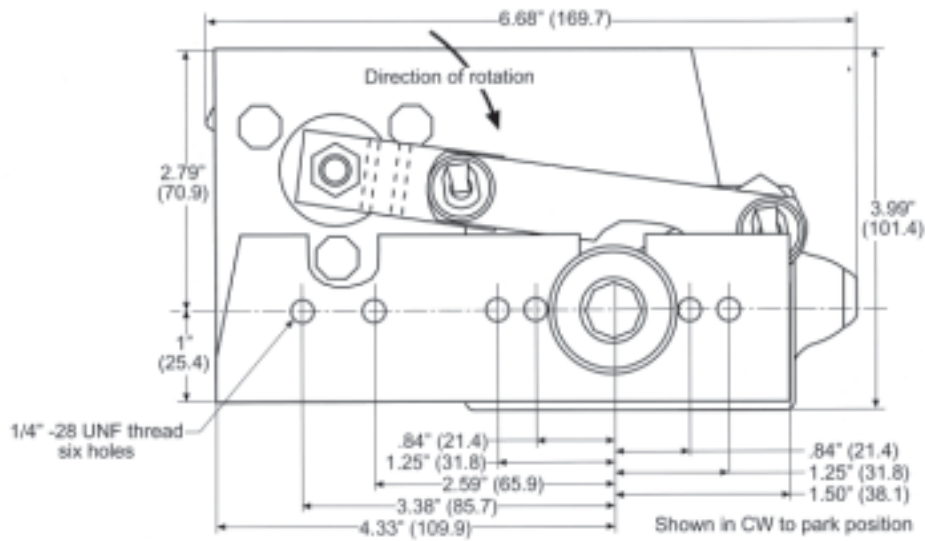

**Wiper
Solutions**

DC Electric Wiper Motors

PART No: TC180 - 12 volt

PART No: TC180 - 24 volt

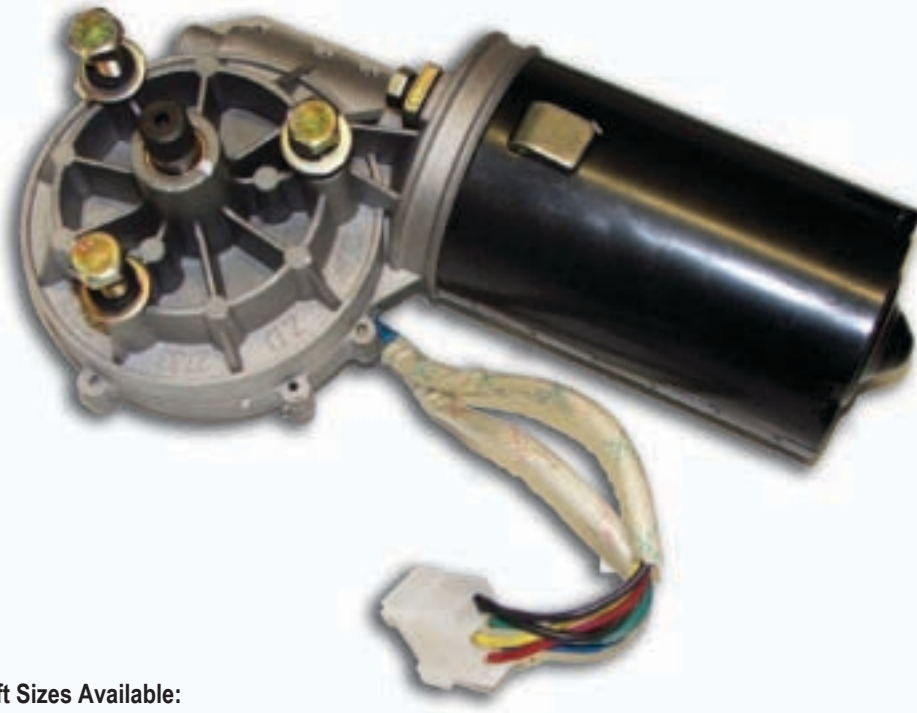

Shaft Sizes Available:
13.2mm, 15.3mm & 16mm

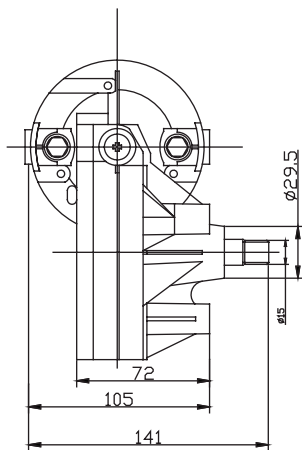
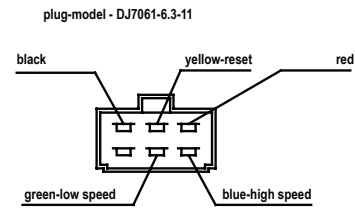
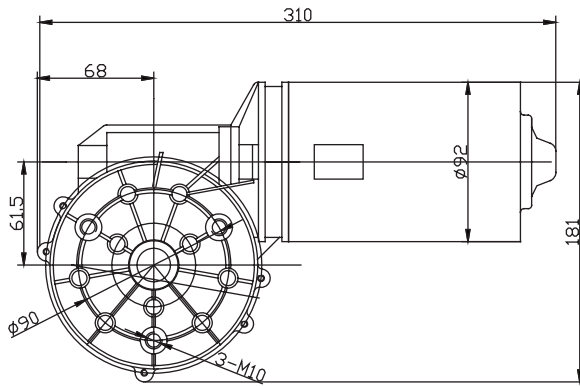

TECHNICAL SPECIFICATIONS

VOLTAGE	12 VOLT / 24 VOLT
TEST VOLTAGE	13.5 VOLT / 27 VOLT
BRAKE TORQUE	102Nm
WORKING TORQUE	17Nm
NOISE	< 53dB(A)
NO-LOAD SPEED (LOW)	30 ± 3 RPM
NO-LOAD SPEED (HIGH)	50 ± 5 RPM
NO-LOAD CURRENT (LOW)	< 5A (12V) < A2.5 (24V)
NO-LOAD CURRENT (HIGH)	< 10 A (12V) < 5A (24V)
WORKING SPEED (LOW)	28 ± 3 RPM
WORKING SPEED (HIGH)	45 ± 5 RPM
WORKING CURRENT (LOW)	< 15A (12V) < 7.5A (24V)
WORKING CURRENT (HIGH)	< 19A (12V) < 9.5A (24V)

DC Electric Wiper Motors

**TRU
Vision**

PART No: TC150 - 12 volt

PART No: TC150 - 24 volt

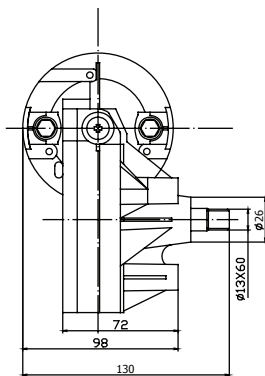
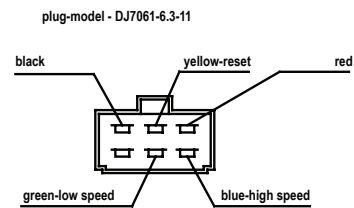
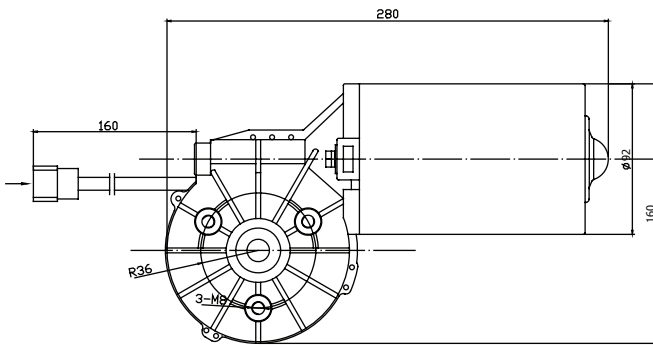

TECHNICAL SPECIFICATIONS

VOLTAGE	12 VOLT / 24 VOLT
TEST VOLTAGE	13.5 VOLT / 27 VOLT
BRAKE TORQUE	85Nm
WORKING TORQUE	17Nm
NOISE	< 53dB(A)
NO-LOAD SPEED (LOW)	30 ± 3 RPM
NO-LOAD SPEED (HIGH)	50 ± 5 RPM
NO-LOAD CURRENT (LOW)	< 4A (12V) < A2 (24V)
NO-LOAD CURRENT (HIGH)	< 8 A (12V) < 4A (24V)
WORKING SPEED (LOW)	28 ± 3 RPM
WORKING SPEED (HIGH)	45 ± 5 RPM
WORKING CURRENT (LOW)	< 14A (12V) < 7A (24V)
WORKING CURRENT (HIGH)	< 18A (12V) < 9A (24V)

**Wiper
Solutions**

DC Electric Wiper Motors

PART No: 230J654 - 24 volt

PART No: 230J652 - 12 volt

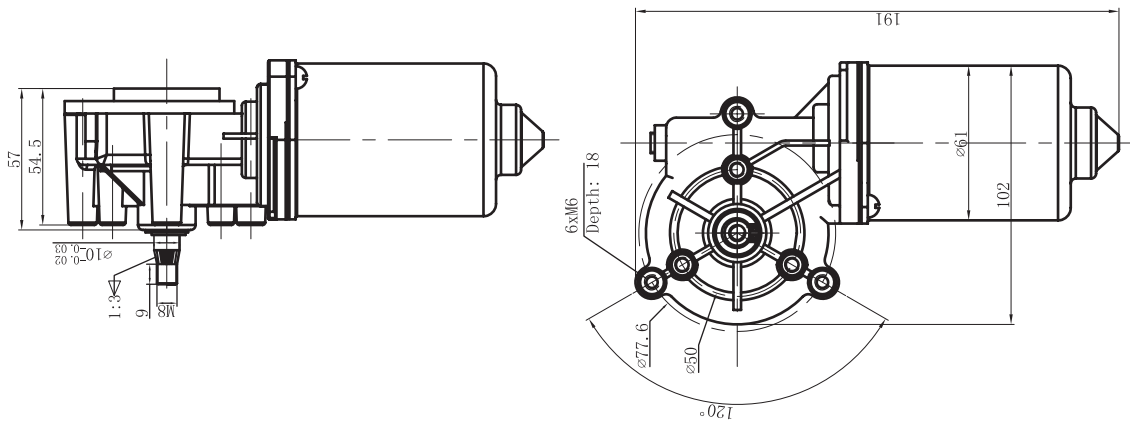

Circuit Diagram

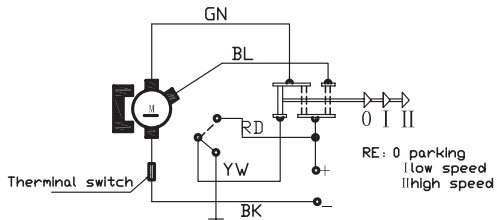

Connector

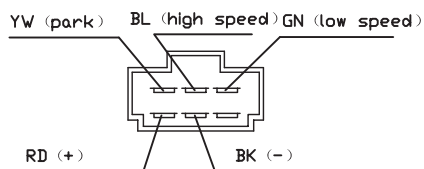

TECHNICAL SPECIFICATIONS

VOLTAGE	12 VOLT / 24 VOLT
TEST VOLTAGE	13.5 VOLT / 27 VOLT
BRAKE TORQUE	30Nm
WORKING TORQUE	8Nm
NOISE	55dB(A)
NO-LOAD SPEED (LOW)	30 ± 3 RPM
NO-LOAD SPEED (HIGH)	50 ± 5 RPM
NO-LOAD CURRENT (LOW)	< 3A (12V) < A2 (24V)
NO-LOAD CURRENT (HIGH)	< 6A (12V) < 4A (24V)
WORKING SPEED (LOW)	28 ± 3 RPM
WORKING SPEED (HIGH)	45 ± 5 RPM
WORKING CURRENT (LOW)	< 6A (12V) < 4A (24V)
WORKING CURRENT (HIGH)	< 10A (12V) < 6A (24V)

DC Electric Wiper Motors

PART No: TC325 - 24 volt

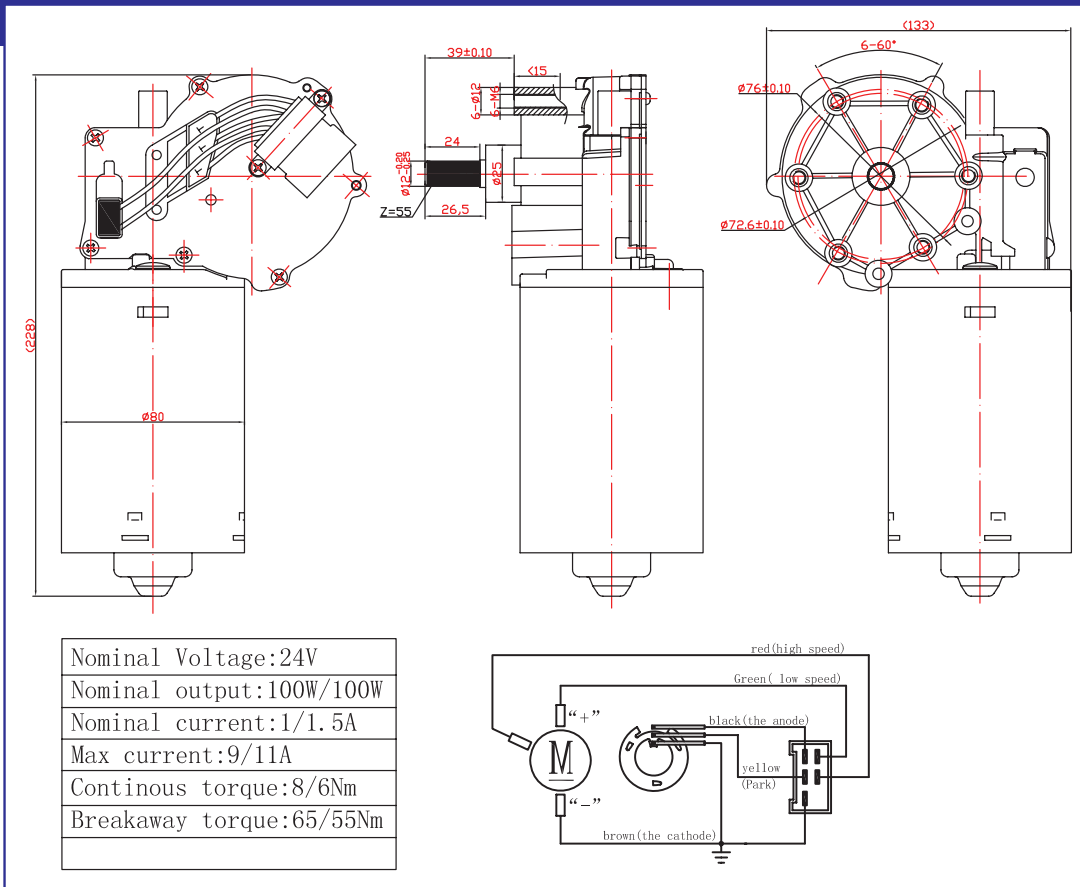

PART No: TC401821 - 24 volt

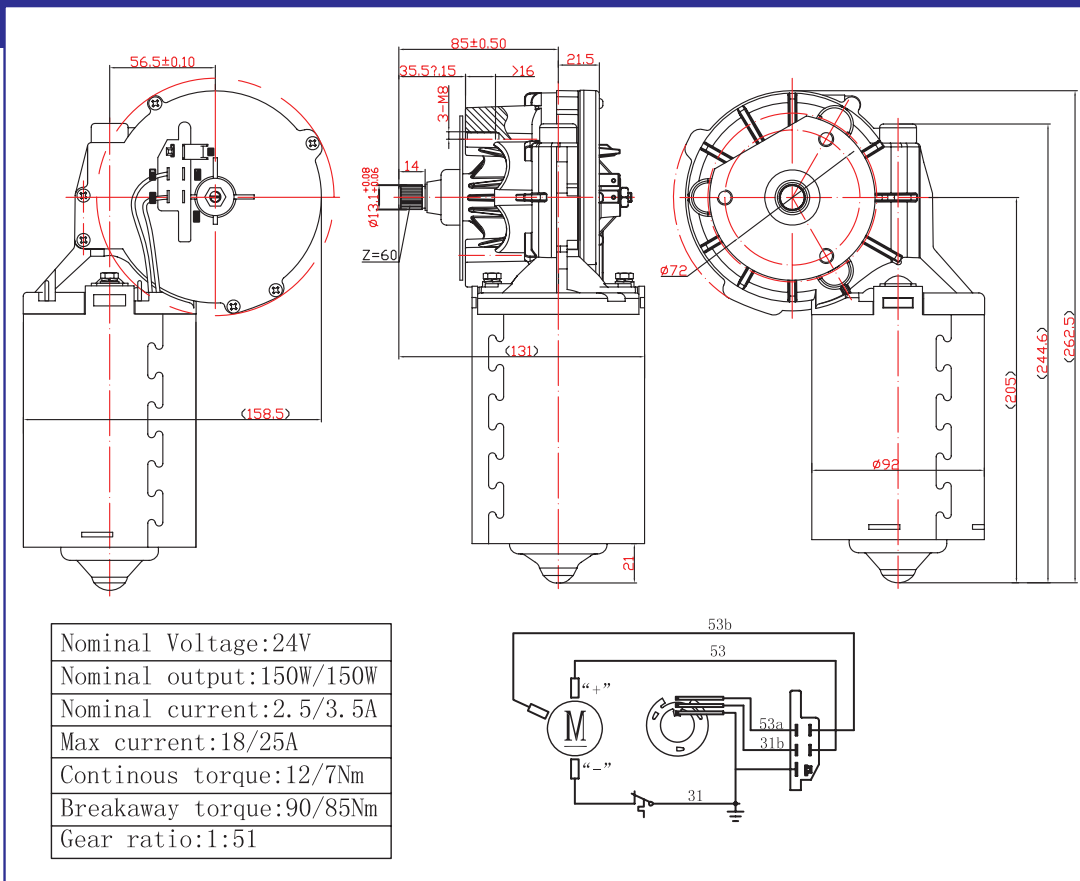

Heavy Duty SWF Style Parts

PART No: TC102665 Single Pivot

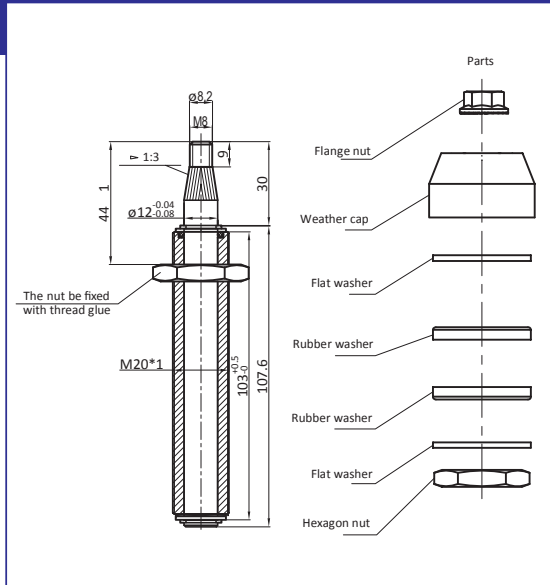

PART No: TC102666 Single Pivot

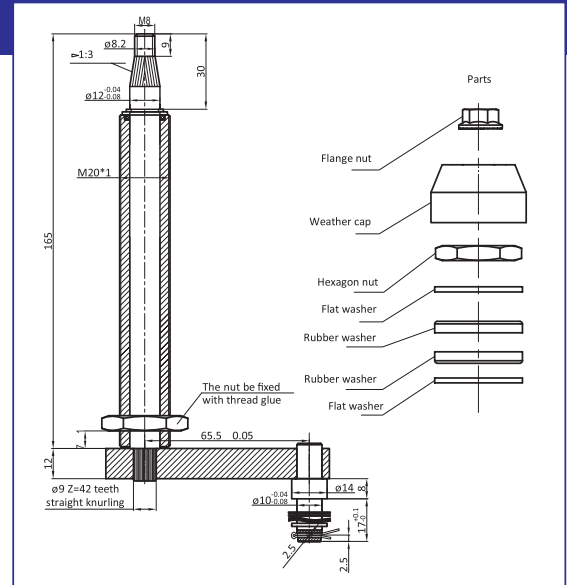

PART No: TC107313 Double Pivot

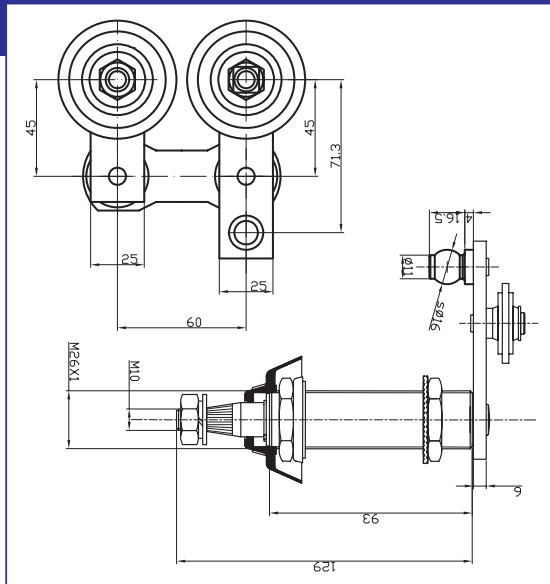

PART No: TC106-669 Centre Pivot

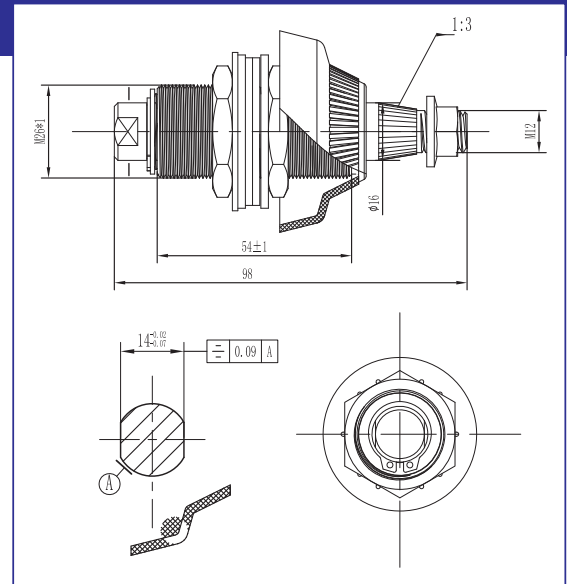

PART No: TC189220K Lever Crank

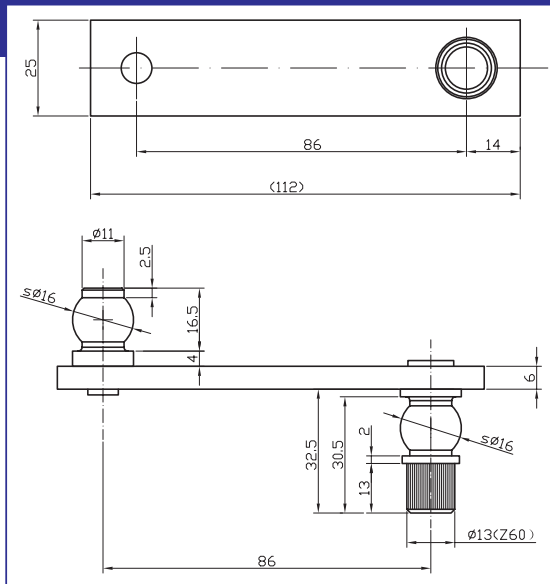

PART No: TC189472 Motor Crank

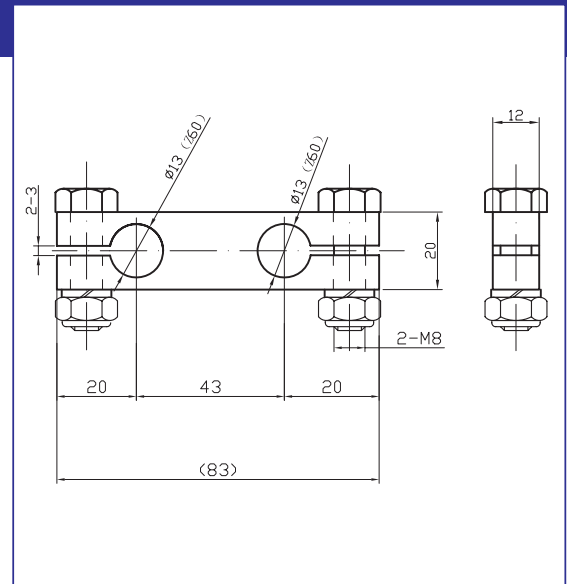

Tru Vision Pivots & Linkages

**TRU
Vision**

PART No: TC458-XX Linkage Series



Adjustable anodised tubular construction with bronze end bushes.

PART No: TC459 Crank Assembly series



PART No: TC Crank-??



Various Crank ends from 9mm - 16mm

PART No: TC456 and TC455 Single and Double Pivots

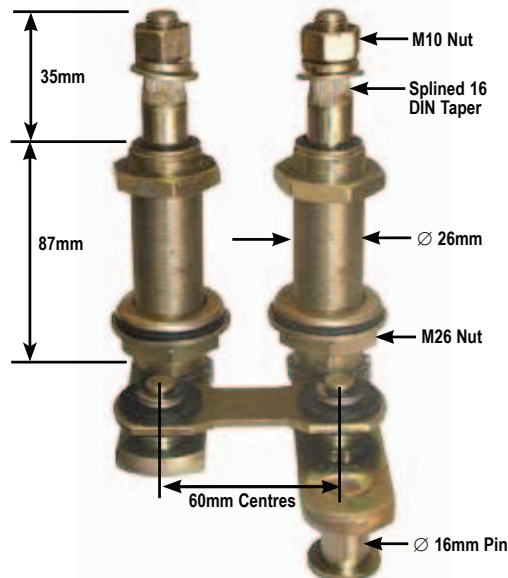

*Wiper
Solutions*

Trico Style Pivots & Linkages

PART No: TC456-XX-YY Pivot REPLACEMENT FOR TRICO Part No: 75353-XX-YY



PART No: TC75366-XX

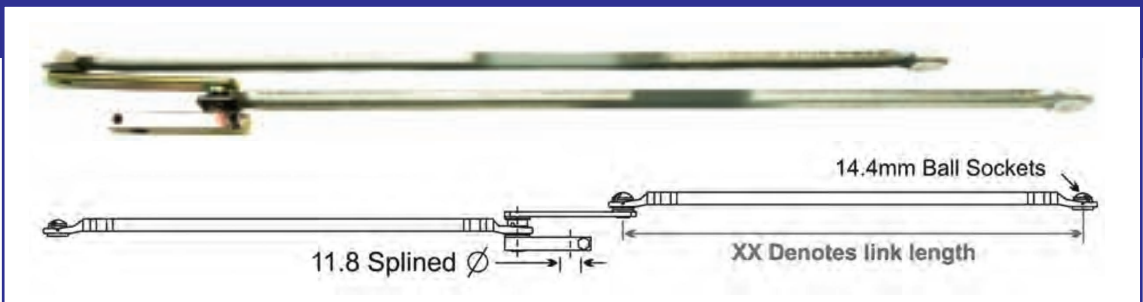

PART No: TV75661

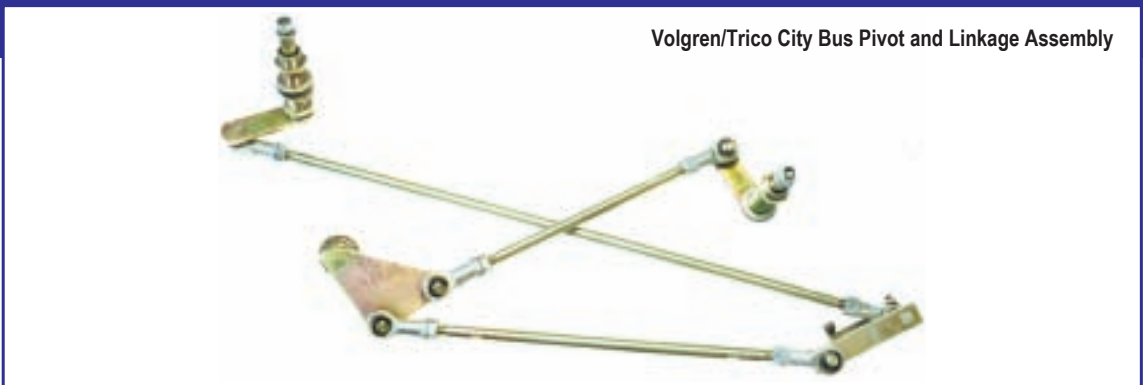

PART No: DOGA LINKAGES VARIOUS



Washer Jets

**TRU
Vision**

PART No: TCJET

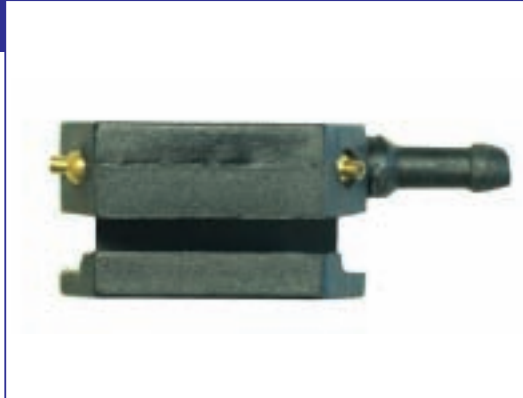

PART No: TCJET777



PART No: TCJET881



PART No: TCJW-01-02

PART No: TCJW-03-04



PART No: TCWJ01

PART No: TCWJ02



PART No: TCB001



PART No: TBF01-02-03



PART No: TCEC01-02-03



**Wiper
Solutions**

Washer Bottles & Pumps

PART No: TCXD-2-12volt

PART No: TCXD-2-24volt



2 Litre Capacity
12 or 24 Volt Fitted Motor

PART No: TCXD-4-12volt

PART No: TCXD-4-24volt

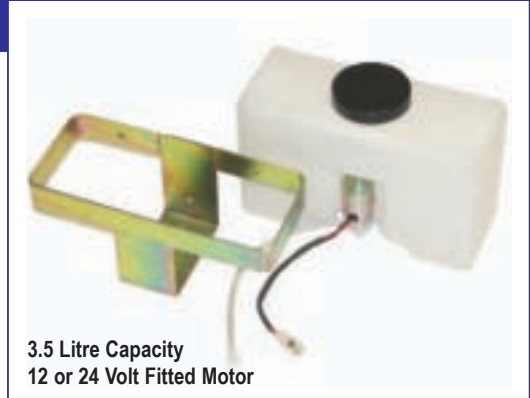

3.5 Litre Capacity
12 or 24 Volt Fitted Motor

PART No: TCXD-5-12V

PART No: TCXD-5-24V



5 Litre Capacity
12 or 24 Volt Fitted Motor

PART No: TCXD-15-12volt

PART No: TCXD-15-24volt



15 Litre Capacity
12 or 24 Volt Fitted Motor

PART No: TCWP-12V

PART No: TCWP-24V



PART No: TCWP15-12V

PART No: TCWP15-24V



PART No: TV109905-24V

PART No: TV109906-12V



PART No: TV826-24V

PART No: TV826-12V



Washer Parts & Switches

PART No: TV010-001-12V

PART No: TV010-001-12V

PART No: TCIL

PART No: TCTP 3

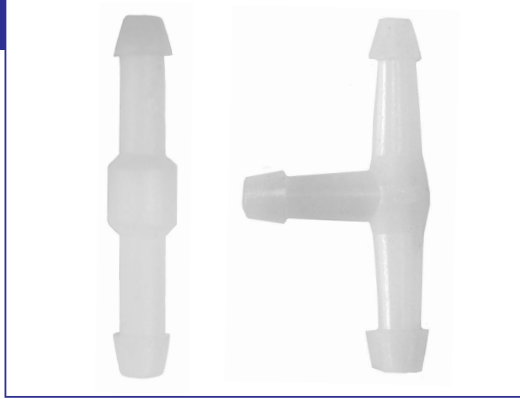

PART No: TCOWV

PART No: TCH4



One Way Valve



3.5mm Washer Hose

PART No: TC228

PART No: TCSW750



Heavy Duty Wiper Switch
- 2 Speed Push To Wash
Suits either 12 or 24 volt



2 Speed Pull/Pull Mechanical Wiper Switch
Suits either 12 or 24 volt

PART No: TC75600-02

PART No: TC-75228-03

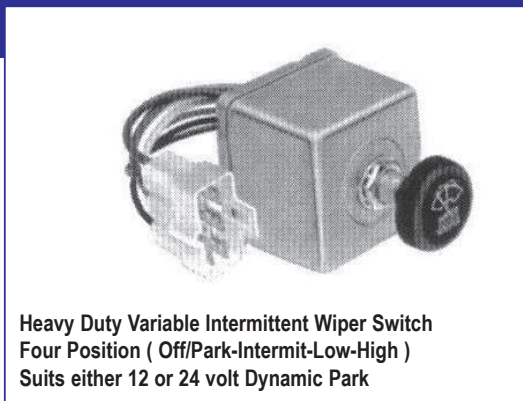

Heavy Duty Variable Intermittent Wiper Switch
Four Position (Off/Park-Intermit-Low-High)
Suits either 12 or 24 volt Dynamic Park

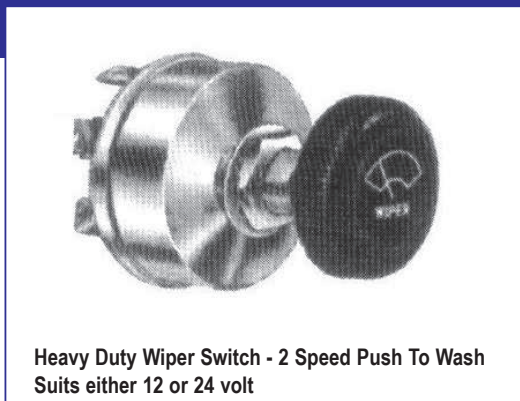

Heavy Duty Wiper Switch - 2 Speed Push To Wash
Suits either 12 or 24 volt

Wiper Specification Request

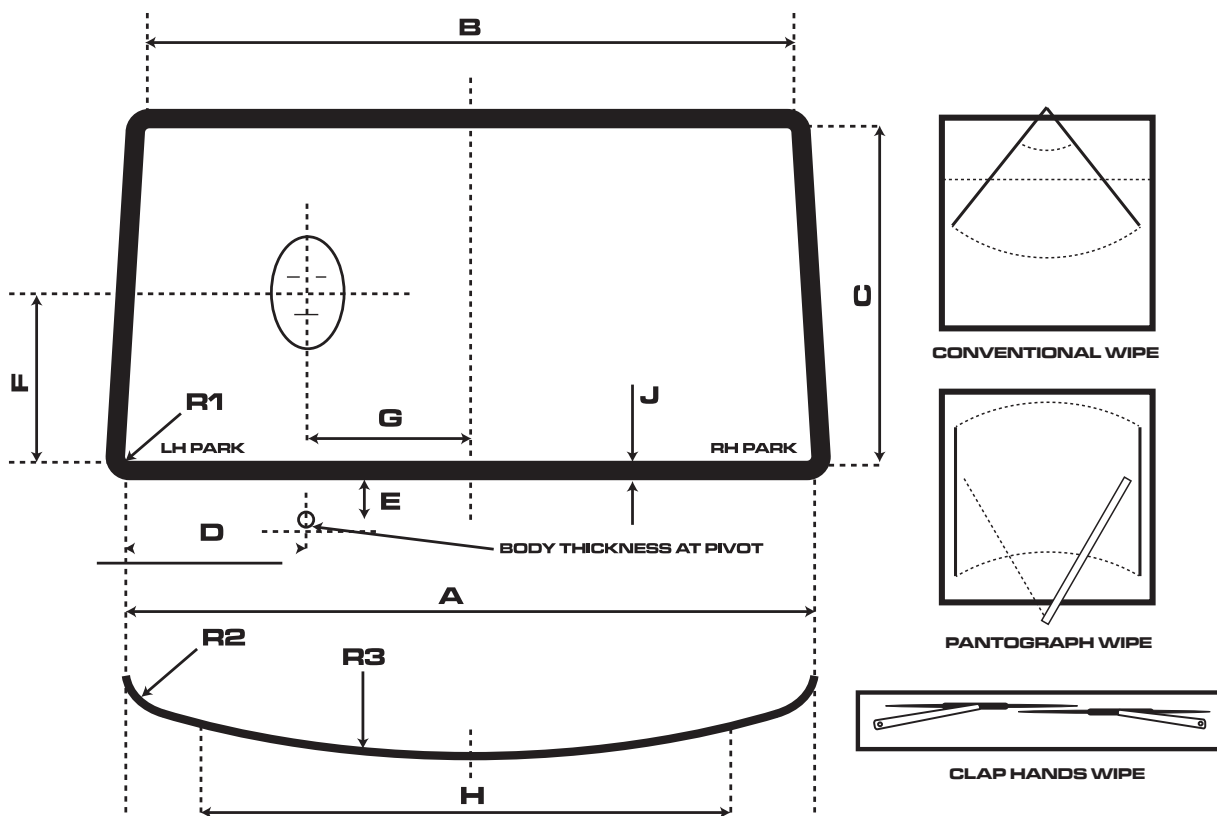

LOOKING FROM THE FRONT OF THE VEHICLE

SPECIFICATION DETAILS

PLEASE CHOOSE MEASUREMENT DETAILS:

CM MM

1. "A" Glass Width - BOTTOM: _____
2. "B" Glass Width - TOP: _____
3. "C" Glass Height: _____
4. "D" Shaft Position: _____
5. "E" Distance From Glass: _____
6. "F" Eye Level: _____
7. "G" Driver Position: _____
8. "H" Windscreen Curve: _____
9. "J" Rubber Surround Size: _____
10. "R1" Windscreen Radius: _____
11. "R2" Windscreen Radius: _____
12. "R3" Windscreen Radius: _____
13. VOLTAGE: 12 Volt 24 Volt
14. MOTOR LOCATION: TOP BOTTOM
15. BODY THICKNESS: _____
16. WIPE PATTERN: CONVENTIONAL PANTOGRAPH CLAP HANDS
17. PARK POSITION: (see diagram) LEFT HAND RIGHT HAND
18. IS SCREEN CURVED OR FLAT CURVED FLAT
19. IS WASHER KIT REQUIRED: YES NO
20. OTHER DETAILS: Vehicle Type, Slopped screen etc. If two blades are driven by one motor, please give relative screen position and motor location.

COMPANY DETAILS

COMPANY NAME: _____ DATE: _____
 ADDRESS: _____
 CONTACT NAME: _____ PHONE: _____ FAX: _____
 EMAIL: _____

General Warranty Statement

TRU VISION PTY LTD
ABN: 59 065 925 126

**TRU
Vision**

GENERAL WARRANTY STATEMENT

Tru Vision Pty. Ltd. (hereinafter called Tru Vision) warrants that the windscreen wiper products supplied by Tru Vision conform and perform with the published technical specifications and any accompanying written materials, and shall be free of defects in materials and workmanship, for the period of time herein indicated, such warranty period commencing upon receipt of the product.

This warranty is limited to the repair and/or replacement, at Tru Vision's discretion, of defective or non conforming product, and Tru Vision shall not be responsible for the failure of the product to perform specified functions, or any other non conformance caused by or attributable to:

- a) Any misapplication or misuse of the product.
- b) Failure of the customer to adhere to any of Tru Vision's specifications or instructions.
- c) Neglect of, abuse of, or accident to, the product.
- d) Any associated or complimentary equipment not furnished by Tru Vision.

Limited warranty service may be obtained by delivering the defective product to Tru Vision or the Distributor it was purchased through and providing proof of purchase.

Customer agrees to insure the product or assume the risk of loss or damage in transit, to prepay shipping charges to Tru Vision or it's distributor.

LIMITATION OF LIABILITY

Except as expressly provided herein, Tru Vision makes no warranty of any kind, expressed or implied, with respect to any equipment, parts or services provided pursuant to this agreement, including but not limited to the implied warranties of merchantability and fitness for a particular purpose. Neither Tru Vision nor it's distributor shall be liable for any other damages, including but not limited to direct, indirect, incidental, special or consequential damages, whether in an action or tort (including negligence and strict liability), such as, but not limited, loss of anticipated profits or benefits resulting from, or arising out of, or in connection with the use of furnishing of equipment, parts or services hereunder or the performance, use or inability to use the same, even if Tru Vision or it's distributor has been advised of the possibility of such damages, in no event will Tru Vision or it's distributor total liability exceed the price paid for the product.

PRODUCT WARRANTY DETAIL

WARRANTY PERIOD:

Tru Vision warrants all of its windscreen wiper products for one (1) year.
A extended warranty period of two (2) years can be made available under certain terms and conditions. (See Tru Vision Head Office)

WARRANTY PROCEDURE:

Upon return of the product, Tru Vision will, at its option, repair or replace the product at no additional charge, freight prepaid, except as set forth below. Repair parts and replacement product will be furnished on an exchange basis and will either be reconditioned or new. All replaced parts or product become the property of Tru Vision.

If Tru Vision determines that the product or part is not covered by warranty, it will at the customer's option, repair the product or part using Tru Vision's standard rates for parts and labour and return the product or parts at no charge in or out of warranty.

WARRANTY EXCLUSIVE: DAMAGES CASUED BY:

- Accidents, falls, objects striking the Tru Vision products.
- Operating the products in environments that exceed normal temperature and humidity specifications.
- Power fluctuation, high voltage discharges.
- Improper grounding, incorrect cabeling.
- Misuse, negligence by the customer or any other third party.
- Failure to install or operate the product(s) in accordance with Tru Vision manuals.
- Failure caused by improper or inadequate maintenance by the customer or any other third party.
- Floods, lightning, earthquakes.
- Water spills. (electric motors)
- Replacement of parts due to normal wear and tear.
- Product has been altered in any way.
- Product that has been exposed to repair attempts by a third party without Tru Vision's written consent.

DISCLAIMER

Whilst all care has been taken in the preparation of the product catalogue, Tru Vision will not be responsible for any errors or omissions contained within.

Products and specifications may be changed at any time without prior notice.

*Wiper
Solutions*

Distributed by:

**TRU
Vision**

PREMIUM WIPER EQUIPMENT

TRU VISION PTY LTD

P.O. Box 1148

Browns Plains, Qld 4118 Australia

Ph: +61 (0)7 3806 7822 Fax: +61 (0) 7 3806 9822