

# LED Step Light • 0.3 Watt Mini Crescent

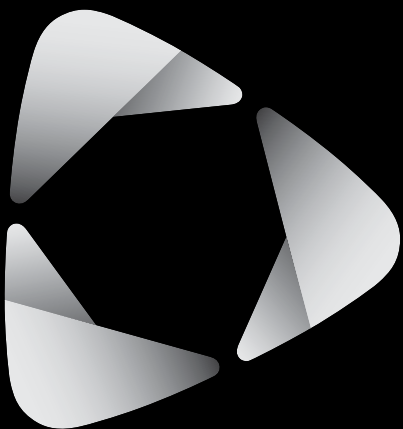

**SSI**

the LED lighting source™

COMMERCIAL • LANDSCAPE • ARCHITECTURAL • RESIDENTIAL



the LED lighting source™

COMMERCIAL • LANDSCAPE • ARCHITECTURAL • RESIDENTIAL

15 Brownridge Rd. Unit 6, Halton Hills, ON L7G 0C6 • 905-487-8192 • 1-877-LED-2DAY • SGI Lighting.com

Project: \_\_\_\_\_

Client: \_\_\_\_\_

Part #: STEP - P - 1W - MCRE - 12VDC - fin - 120 - lc

Date:      /      /      Qty: \_\_\_\_\_

SPECIFICATION

## LED Step Light • 0.3 Watt Mini Crescent



<b>Operating Voltage (ov)</b>	12V DC Constant Voltage			
<b>Finish (fin)</b>	WHT BLK	White* Black*	SST BNZ	Stainless Steel Architectural Bronze*
<b>Beam Angle (ba)</b> Degrees	120°			
<b>Light Colour (lc)</b> Correlated Colour Temperature (CCT)	2700K Incandescent White 3000K Warm White 4000K Neutral White 5000K Cool White Specify Kelvin (K) for other CCTs* R Red* G Green* B Blue* A Amber*			
<b>Light Output</b> Lumens	3000K 4000K 5000K	21 22.5 24		
<b>IP Rating</b>	IP65			
<b>Dimension</b> Diameter, Fixture Height (full height), Trim Height, Hole Size	D FH TH HS	0.98" 1.53" 0.19" 0.62"	25 mm 39 mm 5 mm 16 mm	
<b>Housing</b>	Stainless Steel			
<b>Watts</b>	0.3W			
<b>Light Source</b>	1 x 0.3W LED			
<b>Input Voltage</b>	AC 100V – 240V, 277V external transformer			
<b>Dimmable</b>	Yes With dimmable transformer			
<b>Operating Temperature</b>	-25°C to +50°C -13°F to 122°F			
<b>Life</b> Lumen Maintenance	50,000 hours			

### Part Number Configuration – STEP-P-1W-MCRE-ov-fin-ba-lc

Category	Grade	Family	Operating Voltage (ov)	Finish (fin)	Beam Angle (ba)	Light Colour (lc)
STEP	P-Professional	1W MCRE	12VDC	SST Stainless Steel WHT White BLK Black BNZ Bronze	120°	2700K IW 3000K WW 4000K NW 5000K CW R* G* B* A*

\* Available on special order



the LED lighting source™  
 COMMERCIAL • LANDSCAPE • ARCHITECTURAL • RESIDENTIAL

15 Brownridge Rd. Unit 6, Halton Hills, ON L7G 0C6 • 905-487-8192 • 1-877-LED-2DAY • SGIlighting.com

Project: \_\_\_\_\_

Client: \_\_\_\_\_

Part #: STEP - P - 1W - MCRE - 12VDC - fin - 120 - lc

Date: dd / mm / yyyy Qty: \_\_\_\_\_

INSTALLATION

# LED Step Light • 0.3 Watt Mini Crescent • Installation Guide

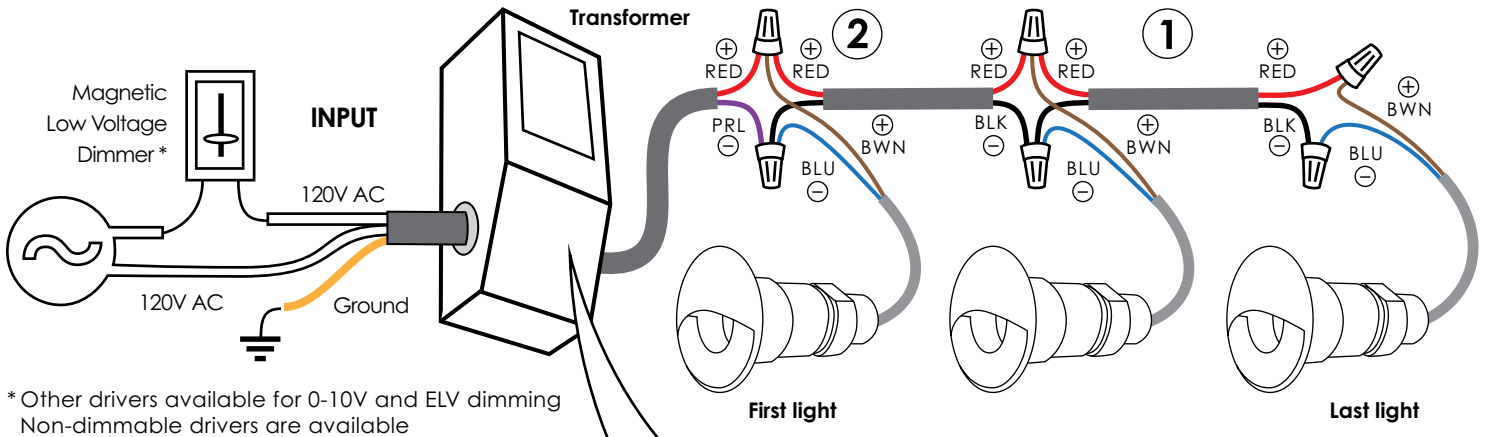

\*Other drivers available for 0-10V and ELV dimming  
 Non-dimmable drivers are available

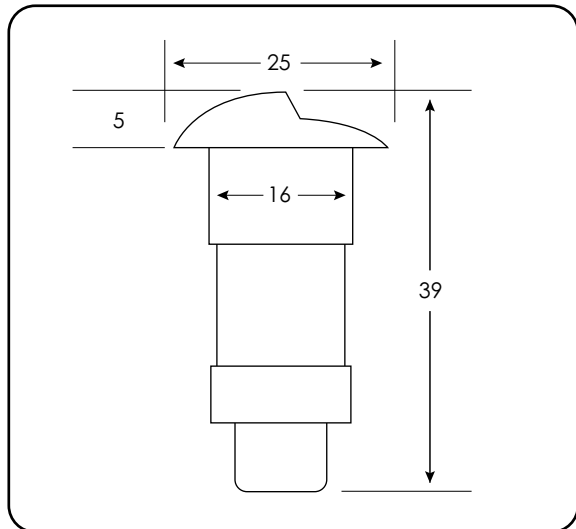
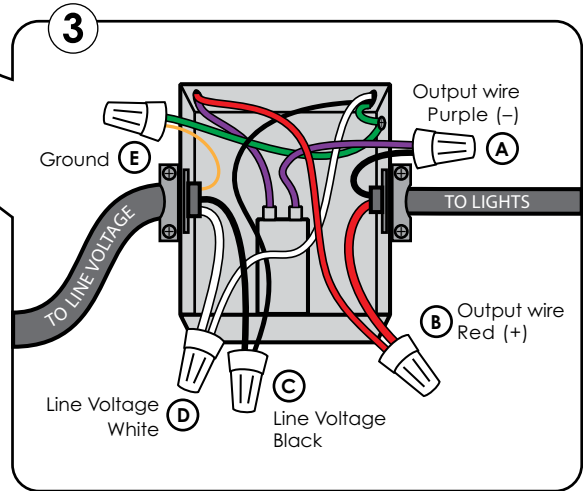
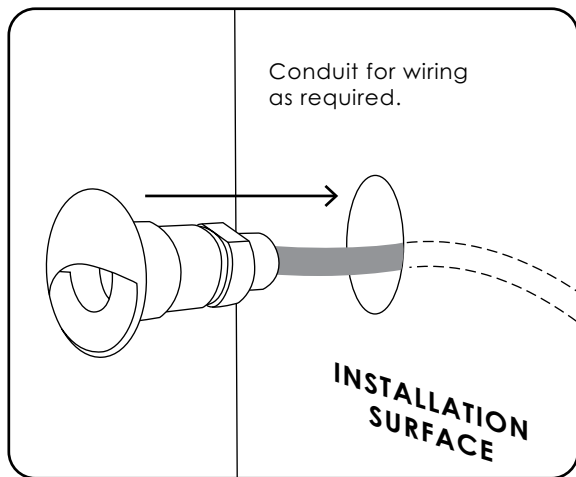

1. Connect a main line of 14 or 16 AWG 2 conductor shielded cable from transformer to furthest light.
2. Connect each light to main cable run coming from the transformer in parallel connection as shown above.  
 Brown wire from Light (+) to Red wire from Transformer (+)  
 Blue wire from Light (-) to Purple wire from Transformer (-)
3. Connect power to transformer as shown.

Installation clips provided. Alternatively, lights can be secured by siliconging fixture onto the installation surface.

Dimensions in millimetres.