

# PITOT and STATIC SYSTEM TESTER

## Model 377-4

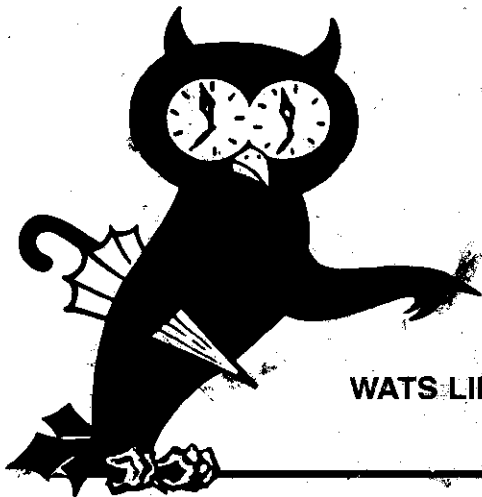
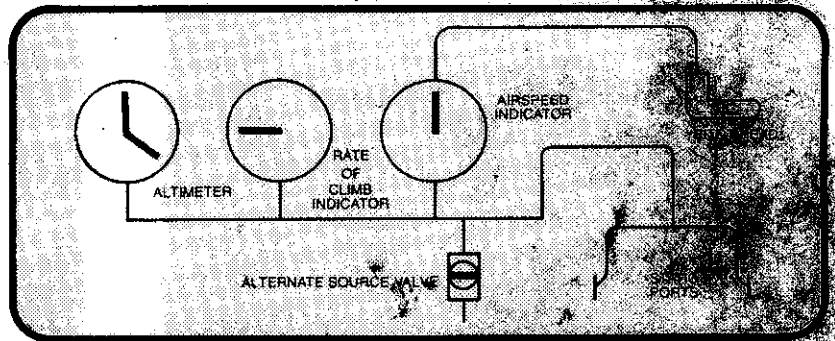
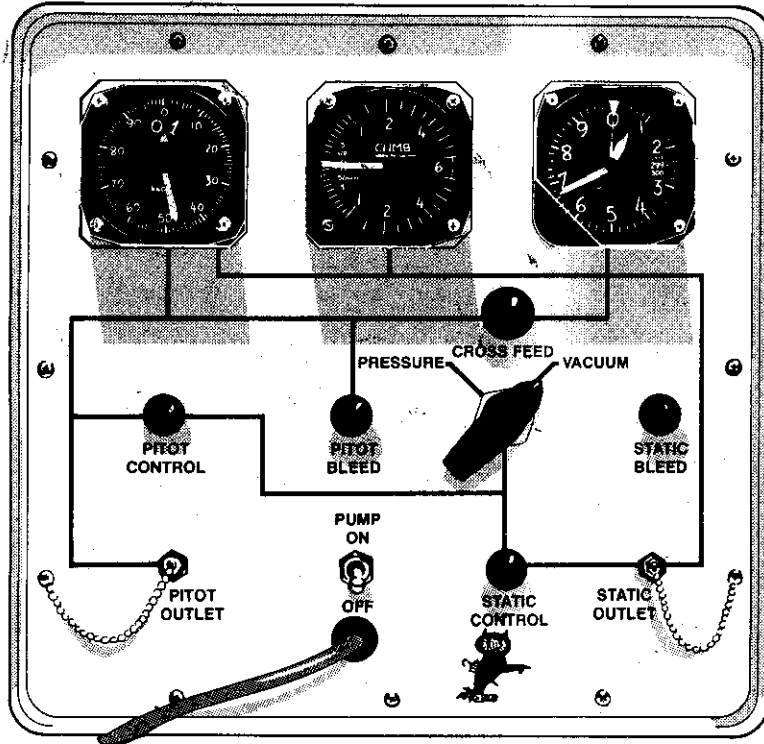

**CASTLEBERRY**  
**INSTRUMENTS and AVIONICS**

817 DESSAU RD. AUSTIN, TEXAS 78753

PHONE 512-251-3443

WATS LINE — 800-531-5200 U.S. Only, 800-252-9173 Texas Only

# **PILOT AND STATIC SYSTEM TESTER MODEL 377-4**

This manual provides information necessary for operating the Pitot and Static System Tester Models 377-4 and 377-4-50K.

This manual is printed to aid the technician in the field and *is not* the final authority for any test undertaken. It is the operator's responsibility to secure all required authority and rules to comply with FAA regulations.

Manufactured by:  
CASTLEBERRY INSTRUMENTS & AVIONICS, INC.  
817 Dessau Road, Austin, TX 78753  
512-251-3441

# table of contents

	Page
<b>SECTION 1 INTRODUCTION</b> .....	<b>1-1</b>
1.1 Purpose of Manual .....	1-1
1.2 Basic Pitot-Static System .....	1-2
<b>SECTION 2 GENERAL DESCRIPTION</b> .....	<b>2-1</b>
2.1 General Description .....	2-1
<b>SECTION 3 PRINCIPLE OF OPERATION</b> .....	<b>3-1</b>
3.1 General .....	3-1
3.2 Electric Circuit .....	3-1
3.3 Pneumatic Circuit .....	3-1
<b>SECTION 4 DETAILED DESCRIPTION</b> .....	<b>4-1</b>
4.1 General .....	4-1
<b>SECTION 5 MAINTENANCE</b> .....	<b>5-1</b>
5.1 General .....	5-1
5.2 Testing .....	5-1
5.2.1 Test Equipment Required .....	5-1
5.2.2 Test Procedures .....	5-1
5.3 Troubleshooting .....	5-4
5.3.1 General .....	5-4
5.3.2 Troubleshooting chart .....	5-4
5.4 Disassembly .....	5-5
5.4.1 General .....	5-5
5.4.2 Removal of Instruments .....	5-5
5.4.3 Removal of Panel .....	5-5
5.4.4 Removal of Valves .....	5-6
5.4.5 Removal of Pump Switch S1 .....	5-6
5.4.6 Removal of Capacitor C1 .....	5-6
5.4.7 Removal of Pump VP1 .....	5-6
5.5 Assembly .....	5-6
5.5.1 General .....	5-6
5.5.2 Replacement of Pump VP1 .....	5-6
5.5.3 Replacement of Capacitor C1 .....	5-6
5.5.4 Replacement of Pump Switch S1 .....	5-6
5.5.5 Replacement of Valves .....	5-6
5.5.6 Replacement of Panel .....	5-6
5.5.7 Replacement of Instruments .....	5-6
<b>SECTION 6 PARTS LIST</b> .....	<b>6-1</b>
<b>SECTION 7 SPECIFIC TESTS</b> .....	<b>7-1</b>
7.1 General .....	7-1
7.2 Test Procedure .....	7-1
7.2.1 Test Equipment .....	7-1
7.2.2 General .....	7-1
7.2.3 Bench Tests .....	7-1
7.2.3.1 Altimeter Bench Test .....	7-1
7.2.3.2 Encoding Altimeter Bench Test .....	7-7
7.2.3.3 Airspeed Indicator Bench Test .....	7-9
7.2.3.4 Climb Indicator Bench Test .....	7-12
7.2.3.5 Air Data Computer Bench Test .....	7-14
7.2.4 Ramp Tests .....	7-20
7.2.4.1 Static System Leak Test (Unpressurized Aircraft) .....	7-20
7.2.4.2 Airspeed and Pitot System Test .....	7-23
7.2.4.3 Static System Leak Test (Pressurized Aircraft) .....	7-26
7.2.4.4 Altimeter Test and Certification .....	7-29
7.2.4.5 Data Correspondence Test .....	7-31
7.2.4.6 Air Data Computer Test .....	7-32
<b>SECTION 8 APPENDIX</b>	

## list of illustrations

Figure		Page
1.1	377-4 Pitot and Static System Tester .....	1-0
1.2	Static Port .....	1-1
1.3	Pitot Static head .....	1-1
1.4	Single Pitot and Static System .....	1-2
3.1	Electrical and Pneumatic Schematic .....	3-1
4.1	377-4 Pitot and Static System Tester, Control Panel .....	4-2
7.1	Typical Altimeter Bench Test setup .....	7-2
7.2	Typical Encoding Altimeter Bench Test setup .....	7-7
7.3	Typical Airspeed Indicator Bench Test setup .....	7-9
7.4	Typical Climb Indicator Bench Test setup .....	7-12
7.5	Typical ramp test setup for Static System Leak Test for unpressurized aircraft .....	7-20
7.6	Typical ramp test setup for Airspeed and Pitot System Test .....	7-23
7.7	Typical ramp test setup for Static System Leak Test for pressurized aircraft. ....	7-26
7.8	Typical ramp test setup for Altimeter Test and Certification .....	7-29
7.9	Typical ramp test setup for Data Correspondence Test. ....	7-31

## list of tables

Table		Page
4-1	Controls and Indicators .....	4-1
5-1	Test Equipment Required .....	5-1
5-2	Test Procedure .....	5-2
5-3	Troubleshooting Chart .....	5-4
7-1	Test Equipment .....	7-1
7-2	Altimeter Bench Test .....	7-3
7-3	Encoding Altimeter Bench Test .....	7-8
7-4	Airspeed Indicator Bench Test .....	7-10
7-5	Climb Indicator Bench Test .....	7-13
7-6	Air Data Computer Bench Test .....	7-15
7-7	Static System Leak Test (Unpressurized aircraft) .....	7-21
7-8	Airspeed and Pitot System Test .....	7-24
7-9	Static System Leak Test (Pressurized Aircraft) .....	7-27
7-10	Altimeter Test and Certification .....	7-30
7-11	Data Correspondence Test .....	7-32
7-12	Air Data Computer Test .....	7-33

## list of appendixes

8-1	FAR 91.170
8-2	FAR 43 Appendix E and F
8-3	Sample Altimeter Test Recording Sheet
8-4	Maximum Cabin Differential Test Pressure Versus Test Altitude
8-5	FAR 43.9
8-6	FAR 91.177
8-7	FAR 91.36
8-8	FAR 23.1325
8-9	FAR 25.1325
8-10	AC 43.13-1 change 2
8-11	AC 43.203B
8-12	AC 43.6A
8-13	AC 91-14D
8-14	FAR 37.112
8-15	AS 391C
8-16	FAR 37.118
8-17	AS 394A
8-18	FAR 37.145



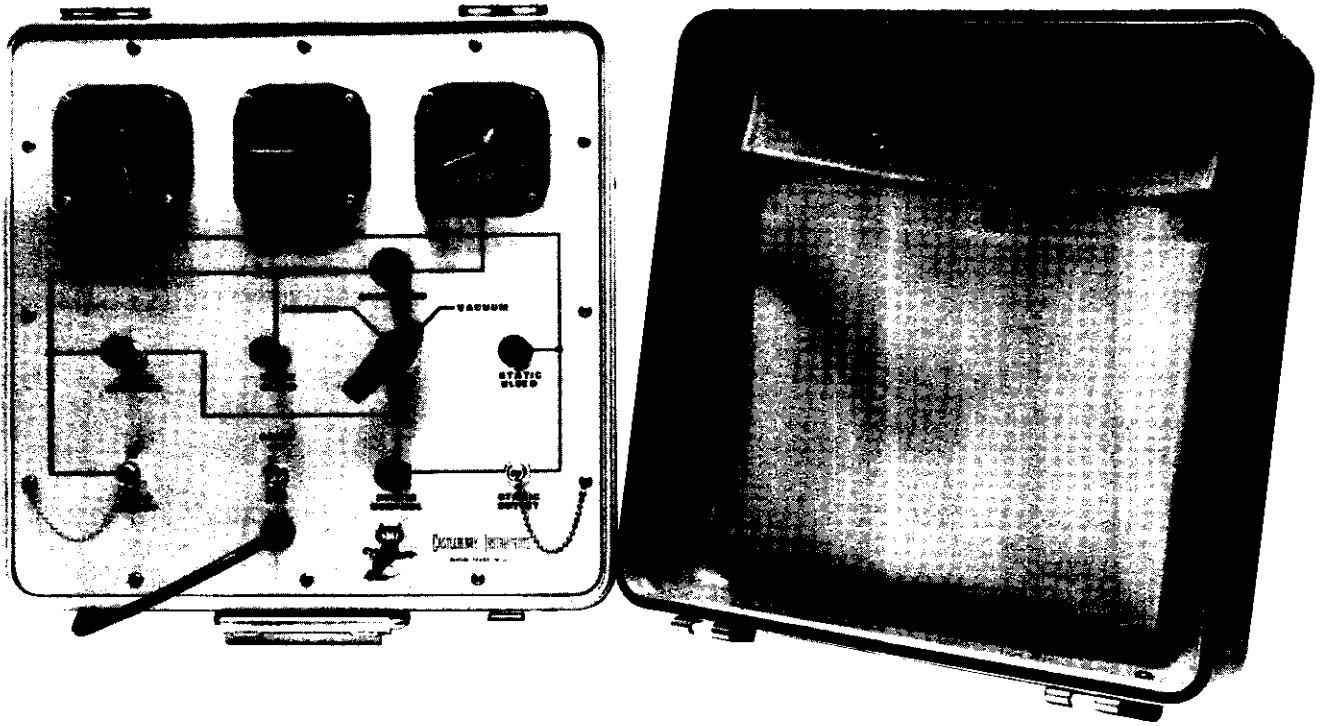

Figure 1.1 377-4 Pitot and Static System Tester

## 1.1 PURPOSE OF MANUAL

The purpose of this manual is twofold: to make your job as easy as possible to comply with FAA regulations with an indepth understanding of Pitot and Static Systems of today's aircraft; and to give you detailed information on the Model 377-4 Pitot and Static System Tester.

This technical manual is not intended to be a comprehensive "textbook". It does, however, present a thorough overview of the unique requirements of Pitot and Static Systems test and certification. It includes many illustrations and "how-to" tips and ideas, plus copies of related Federal Aviation Regulations; Appendixes and Advisory Circulars. It has been organized in such a manner that if one reads it from cover to cover they will have a comprehensive understanding of the aircraft's systems and how to perform the necessary tests and repairs.

It is with these thoughts in mind that we at Castleberry Instruments and Avionics wish you many years of successful testing with our Model 377-4. If you have any questions or problems, please feel free to call us.

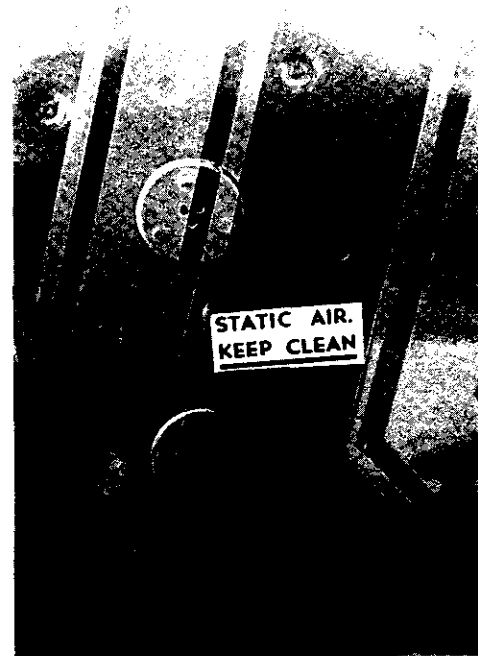

Figure 1.2 Static Port

## 1.2 BASIC PITOT-STATIC SYSTEM

The system that provides pressure for the altimeter indicator is the only one for which the Federal Aviation Regulations specifically require an inspection. FAR 91.170 requires that the static system of every aircraft operated under Instrument Flight Rules be inspected for integrity every twenty-four months and a record kept of those inspections.

Static systems connect the altimeter, airspeed indicator and rate of climb indicator to a port or hole in the side of the aircraft, fig. 1.2 or a hole in the side of the pitot-static head, fig. 1.3. This provides undisturbed air for use as a reference for these instruments.

Pitot heads and static ports are susceptible to blockage by ice, so electric heaters may be installed to prevent its formation. These heaters generate more heat than can be dissipated without a cooling airflow, so the heaters should not be operated on the ground any longer than necessary to insure that they will operate properly.



Figure 1.3 Pitot Static Head

Fig. 1.4 shows a complete single pitot-static system installation. The pitot tube is connected directly to the airspeed indicator, the static ports of the three instruments are manifolded together and connected into common static sump, then to the static ports. There are often two static ports connected together, one on either side of the aircraft, so that in a slipping or skidding condition the pressure on the two sides of the aircraft will balance and a true static reading will be provided.

An alternate source valve may be provided in the static system so that in the event the outside static ports ice over, the pilot can open the valve and have an acceptable, though perhaps not highly accurate, reading. Unpressurized airplanes vent this valve into the cockpit at the instrument panel; but pressurized airplanes must provide the alternate static source outside the pressurized area.

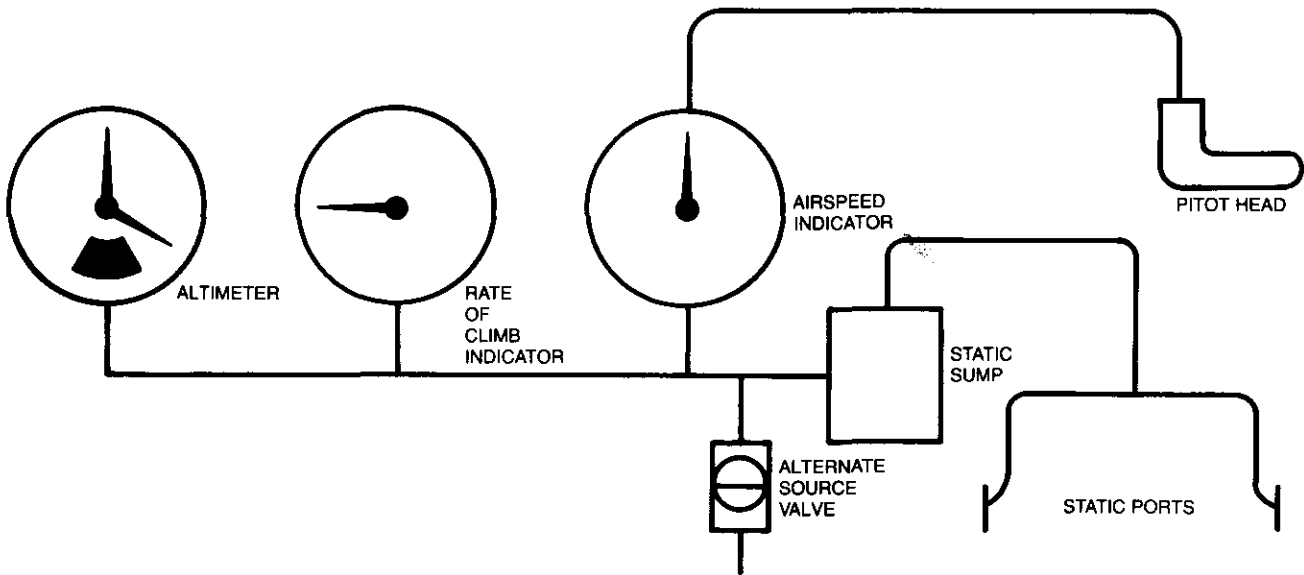

Figure 1.4 Single Pitot and Static System



## section 2

---

### general description

#### 2.1 GENERAL DESCRIPTION

The Model 377-4 Tester is a compact, portable and precise tester, complete with vacuum-pressure pump, valves, hoses, electric cord and monitoring instruments. All components are contained within the fiberglass case, 10 inches high, 15 inches wide and 15 inches deep, weighing 30 pounds.

The 377-4 can be used by one technician for all test procedures right on the aircraft or on the test bench.

The 377-4 produces precise and controlled pressures, pitot and static, that are normally sensed by airborne flight instruments. Through adapter fittings and hose connections, the precise pressures generated by the tester can be applied to the aircraft's normal pitot and static lines or directly to a specific instrument to check for proper operation.

The 377-4 supplies both positive and negative pressure (vacuum). Self-test of the 377-4 can be made quickly and easily at any time.

Instruments used in the 377-4 are highly accurate and sensitive. These instruments are calibrated and certified to FAA Standards under controlled environmental conditions, thus providing a reliable testing standard.

A dry pump is used in the 377-4 which allows it to be carried, stored or operated in any position without fear of fluid contamination of instruments.

Static and pitot pressures are controlled by micro metering valves adjustable at the front panel. These valves also act as shut-off valves to isolate the aircraft

systems and the tester instruments from the testers pressure sources. This isolation provides a means of checking for system leakage by observing a drop in the altimeter and/or airspeed instruments in the 377-4 over a period of time.

Electrical circuit wiring is fused using a 3 ampere fuse to prevent electrical damage to the tester.

Test connection plug fittings are provided with a dual purpose, dust caps to prevent contamination within the 377-4 and to seal the outlet connections ports to make pre-test self-checks of the Tester possible.

Hoses and fittings furnished with the 377-4 allow interconnections with the aircraft's pitot and static ports. Optional adapters and fittings are available on request.

The pump motor operates on 115/110 volts AC, 50/60 cycles or optional 230/220 volts AC 50/60 cycles single phase.

Three precise instruments are used in the typical 377-4 tester. All functions are clearly labeled on the tester's control panel and instrument dials.

- (1) The airspeed (Pitot pressure monitor) dial is calibrated to read indicated airspeed in knots and/or miles per hour depending on choice.
- (2) The altimeter (static pressure monitor) dial is calibrated to indicate altitude in feet.
- (3) The climb (static pressure rate of change monitor) dial is calibrated to indicate altitude rate of change in feet per minute.

### 3.1 GENERAL

This section provides a discussion of principles and major functional loops involved in operation of the 377-4 Pitot and Static System Tester. Schematic diagram figure 3.1 is provided to aid in understanding the functional discussion.

### 3.2 ELECTRIC CIRCUIT

The 377-4 operates on 115 volts 50 or 60 Hz or optional 220 volts 50 or 60 Hz. Pump Power Switch S1 applies power through fuse F1 to the Vacuum-Pressure Pump VP1.

### 3.3 PNEUMATIC CIRCUIT

Selector Valve V1 allows pressure or vacuum from

pump to be routed to Pitot Control Valve V3 and Static Control Valve V2. Pitot Control Valve V3 regulates and isolates pump pressures from/to Pitot Bleed Valve V4, Cross Feed Valve V6, pitot outlet SC1 and Airspeed M3. Static Control Valve V2 regulates and isolates pump pressures from/to Static Bleed Valve V5, Cross Feed Valve V6, Static Outlet SC2, Altimeter M1 and Climb M2. Cross Feed Valve V6, when opened, allows equalization of pressure between pitot and static lines. Therefore, when the same pressure or vacuum is on both connections of the Airspeed, there will be no differential pressure and airspeed will remain at zero. Relief Valve V7 is a safety valve to limit maximum pressure buildup to approximately 15 PSI. Pitot and Static Outlets SC1 and SC2 provide connections to external instruments or systems. Pitot and Static Bleed Valves V4 and V5 allow each system to be vented to the atmosphere.

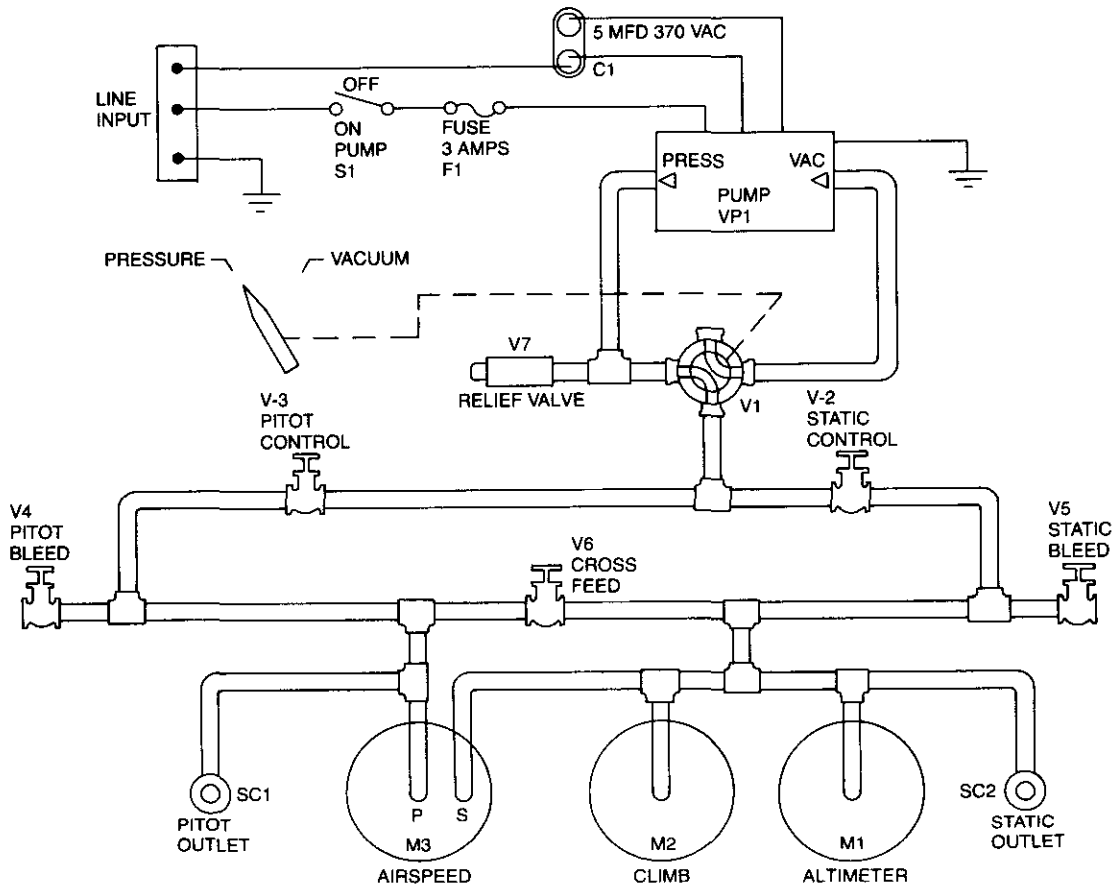

Figure 3.1 Electrical and Pneumatic Schematic

**4.1 GENERAL**

Table 4-1 lists each switch, control and indicator on the 377-4 Pitot and Static System Tester shown in figure 4.1 with its location and function.

*TABLE 4-1. Controls and Indicators*

ITEM NAME	LOCATION	FUNCTION
Airspeed Indicator M3 Knots or MPH	Front Panel	A direct reading instrument that indicates the difference between ram pressure (pitot) of the air and the atmospheric pressure (static).
Altimeter MI 35,000 feet (Standard) 50,000 feet (Optional)	Front Panel	A direct reading instrument that indicates atmospheric pressure (static).
Climb M2 (6,000 feet per minute)	Front Panel	A direct reading instrument that indicates the rate of change in atmospheric pressure (static).
Motor-Pump Unit Dry Type VP1	Internal, accessible after removal of panel.	115/110 volts 60/50 Hertz 1 phase 1.4/1.5 ampere (standard) 230/220 volts 60/50 Hertz 1 phase one (1) ampere (optional). Generates the required pressure.
Power Cord	Front Panel	Heavy duty-three prong 110 volts, 50-60 Hertz (standard); 220 volts 50-60 Hertz (optional). Supplies the power to operate the motor-pump unit.
Power Switch S1	Front Panel	Provides on/off control of power to motor-pump.
Source Selector Control V1	Front Panel	Allows selection of positive or negative (vacuum) pressure.
Static Control V2	Front Panel	Regulates pressure to and isolates the pump pressures from the static outlet and the testers indicators.

TABLE 4.1. Controls and Indicators

ITEM NAME	LOCATION	FUNCTION
Static Bleed V5	Front Panel	Allows the pressures developed in the static lines to be released to the atmosphere.
Pitot Control V3	Front Panel	Regulates pressure to and isolates the pump pressures from the pitot connection on the Testers airspeed.
Pitot Bleed V4	Front Panel	Allows the pressures developed in the pitot lines to be released to the atmosphere.
Cross Feed V6	Front Panel	Allows equalization of pressure between the pitot and static systems.
Accessory Pouch	Inside Lid	Houses hoses, fittings, adapters, manual and test data sheets.

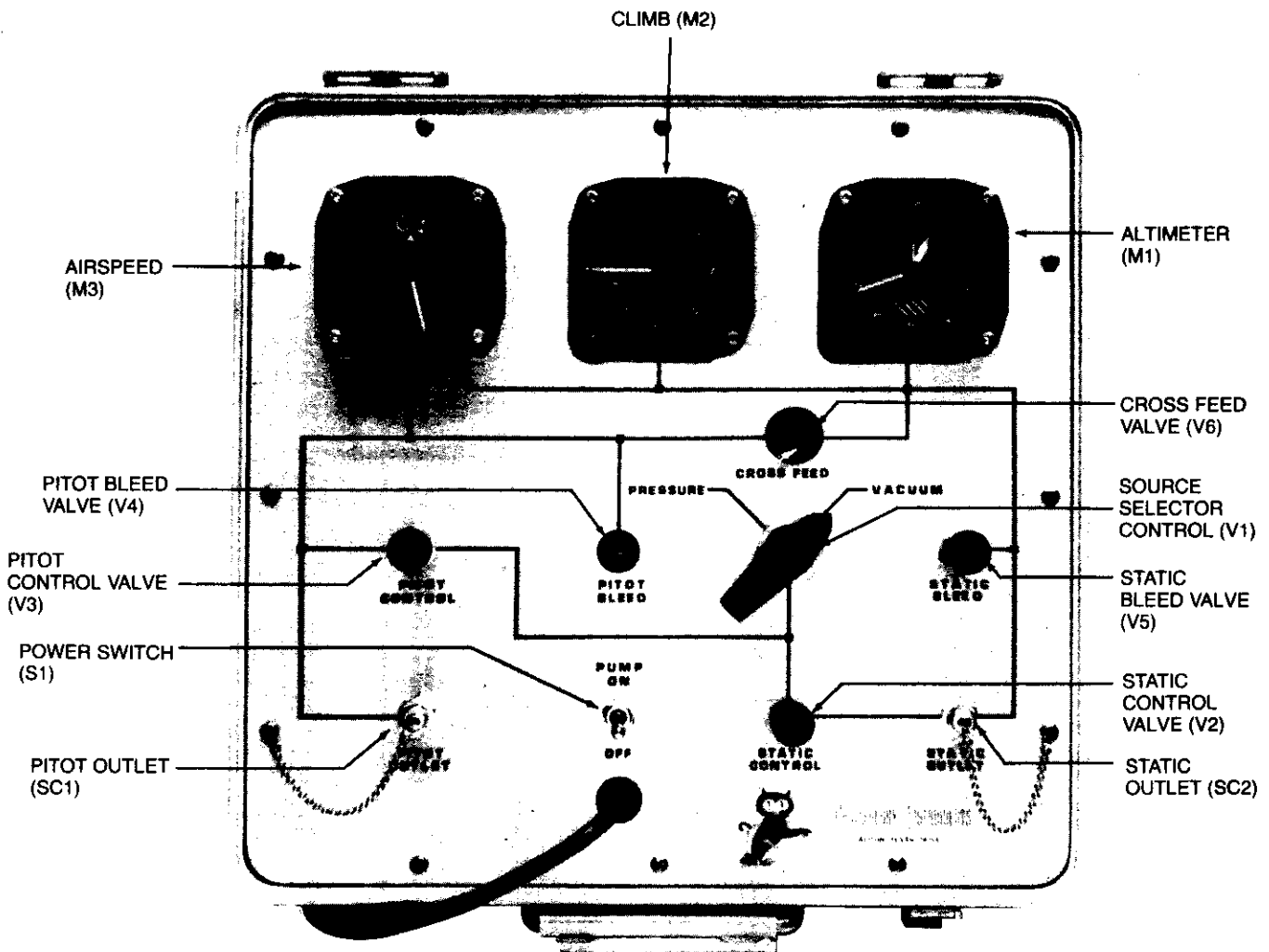

Figure 4.1 377-4 Pitot and Static System Tester, Control Panel

**5.1 General**

This section presents information required for maintenance and repair of the 377-4 Pitot and Static System Tester. The information provided by this section includes testing, troubleshooting, disassembly, servicing and assembly procedures.

**5.2 Testing**

**5.2.1 Test Equipment Required**

The test equipment required to self test the 377-4 Tester is listed in table 5-1. Substitute equipment may be used if equivalent to that listed.

**NOTE:**

Refer to appendix 8-13 AC91-14D for approved altimeter setting sources.

Refer to appendix 8-11 AC43-203B paragraph 7.b.1,2,3 for required calibration checks of test equipment.

**5.2.2 Test Procedures**

*TABLE 5-1. Test Equipment Required*

EQUIPMENT	MFG. & P/N	FUNCTION
Barometer Altimeter Setting	Kearflex Eng. Co. MS24134-1 (FA68AC-3741-3)	Check current altimeter setting.
Surveyed elevation of location		Check field elevation on master altimeter.

**5.2.2.1 General**

The test procedure is presented in table 5-2. If an abnormal result is obtained, refer to the troubleshooting procedure, paragraph 5.3. The following paragraphs list the column headings of the test procedure and describe what is included in each column.

**5.2.2.2 STEP Column**

The STEP column lists the number of the test.

**5.2.2.3 DESCRIPTION Column**

The DESCRIPTION column lists the descriptive name for each test.

**5.2.2.4 PROCEDURE Column**

The PROCEDURE column lists the procedures that are performed as a part of each test.

**5.2.2.5 RESULTS Column**

The RESULTS column is used to list the required indication and to describe any noticeable changes that should occur.

TABLE 5-2. Test Procedure

STEP	DESCRIPTION	PROCEDURE	RESULTS
1	Preliminary test setup		
1a	Master Altimeter M1 field elevation check	<p>Install test plugs in <b>outlet connectors SC1 &amp; SC2.</b></p> <p>Close <b>Pitot and Static Control Valves V2 &amp; V3</b> and <b>Cross feed valve V6</b> fully clockwise.  <b>CAUTION:</b> Do not force valves past their stops as they are "Soft Seat" valves.</p> <p>Open <b>Pitot and Static Bleed Valve V4 and V5</b> at least 3 turns counter clockwise.</p> <p>Set the current barometric setting on <b>altimeter M1</b> and read altitude after vibrating.</p>	<p><b>Altimeter M1 should read</b> field elevation within plus or minus 75 feet.</p>
2	Leak Checks		
2a	Initial Control settings	<p>Install test plugs in <b>outlet connectors SC1 &amp; SC2.</b></p> <p>Close <b>pitot and static control valves V2 &amp; V3</b> and <b>cross feed valve V6</b> fully clockwise.</p> <p>Set <b>Vacuum-Pressure selector V1</b> to "Pressure"  Set <b>Pump switch S1</b> to "OFF".  Connect Power cord to proper power source.  115 VAC 50/60 Hz or optional 220 VAC 50/60 Hz.</p>	
2b	Pitot Leak Check	<p>Set <b>Pump Switch S1</b> to "ON."  Close <b>Pitot Bleed Valve V4</b> fully clockwise.</p> <p>Slowly open <b>Pitot Control Valve V3</b> counterclockwise.</p>	<p>Audible indications of pump running.</p> <p>Airspeed M3 will indicate upscale.</p>

TABLE 5-2. Test Procedure (cont'd)

STEP	DESCRIPTION	PROCEDURE	RESULTS
2b	Pitot Leak Check cont'd	<p>After <b>Airspeed M3</b> has reached its max indications (300 MPH or 650 KTS.) Close Pitot Control V3 fully clockwise.</p>	<p>Observe airspeed for one minute. Indication should not decrease by more than 2 MPH or KTS.</p>
		<p>Slowly open <b>Pitot Bleed Valve V4</b>.</p>	<p><b>Airspeed M3 indications will return to zero or rest position.</b> (Note: Rest Position on 650 KTS type is approximately 45 KTS.)</p>
			<p>Record amount of Pitot Leakage for future reference.</p>
2c	Static Leak Check	<p>Close <b>Pitot and Static Bleed Valves V4 &amp; V5</b> fully clockwise.</p>	
		<p>Open <b>Cross Feed valve V6</b> at least 3 turns counterclockwise. Set <b>Vacuum-Pressure V1</b> to "Vacuum".</p>	
		<p>Slowly open <b>Static Control valve V2</b> counterclockwise until <b>climb M2</b> indicates 5,500 ft. per min. climb. Maintain climb rate until altimeter indicates 20,000 feet.</p>	<p><b>Climb indicator M2</b> indicates a climb. <b>Altimeter M1</b> indicates an increase in altitude. <b>Airspeed M3</b> should remain at zero or rest position.</p>
		<p>Close <b>static control valve V2</b> clockwise and allow a minute or so for <b>climb M2</b> to stabilize on zero.</p>	<p>After <b>Climb M2</b> has stabilized, observe <b>altimeter M1</b> for one minute. Leakage (drop in altitude) should not be more than 50 feet.</p>
		<p>Slowly open <b>static Bleed Valve V5</b> counterclockwise until <b>Climb M2</b> indicates 5,500 ft. per min. dive. Maintain 5,500 ft. per min. dive until <b>altimeter M1</b> indicates field elevation.</p>	<p>Record amount of static leakage for future reference.</p>
		<p>Set <b>Pump switch S1</b> "OFF".</p>	

### 5.3 Trouble Shooting

#### 5.3.1 General

Problems encountered with the 377-4 Pitot and Static System Tester can be isolated using the test procedures and the Troubleshooting chart, Table 5-3.

#### 5.3.2 Troubleshooting chart

##### 5.3.2.1 General

The troubleshooting chart is presented in tabular form. The following paragraphs contain a description of what is found in each column.

##### 5.3.2.2 TEST STEP Column

The TEST STEP column give the same step number for a specific test as was listed in the test procedure, Table 5-2.

##### 5.3.2.3 DESCRIPTION Column

The DESCRIPTION column lists the name of the test accomplished in the test step indicated.

#### 5.3.2.4 ABNORMAL RESULTS Column

The ABNORMAL RESULTS Column lists the results that should not have been obtained in each of the test previously accomplished.

#### 5.3.2.5 PROBABLE CAUSE Column

The PROBABLE CAUSE column lists the most likely cause of an abnormal result, listed in the order of probability.

#### NOTE

The probable cause is determined assuming that each previous test step was satisfactorily completed.

#### 5.3.2.6 CORRECTIVE PROCEDURE Column

The CORRECTIVE PROCEDURE column indicates what can be done to correct the abnormal result that was obtained.

Table 5-3. Troubleshooting Chart

Test Step	Description	Abnormal Result	Probable Cause	Corrective Procedure
1	Preliminary Test Setup			
1a	Master Altimeter Field Elevation Check	Altimeter M1 read off more than 75 feet	Altimeter M1 needs recalibration	Recalibrate or replace M1
			Lines associated with M1 defective	Replace or repair
			Source of Barometric pressure setting inaccurate.	Obtain a different source, compare and recheck altimeter M1.
2	Leak Checks			
2b	Pitot Leak Checks	No audible indication of pump running	Faulty power source	Check Power source for proper output and locate problem.
			Fuse F1 defective	Replace F1
			Switch S1 defective	Replace S1
			Capacitor C1 defective	Replace C1



Table 5-3. Troubleshooting Chart (cont'd)

TEST STEP	DESCRIPTION	ABNORMAL RESULT	PROBABLE CAUSE	CORRECTIVE PROCEDURE			
2b	Pitot Leak Check cont'd	<b>Airspeed M3</b> inoperative	<b>Pump VP1</b> defective	Replace VP1			
			<b>Cross Feed Valve V6</b> open	Close V6			
			<b>Cross Feed Valve V6</b> defective	Replace V6			
			<b>Airspeed M3</b> defective	Replace M3			
			Loose fittings	Locate and repair			
		<b>Airspeed M3</b> has excessive leak	Loose fittings	Locate and repair			
			<b>Airspeed M3</b> defective	Replace M3			
			2c	Static Leak Check	<b>Climb M2</b> inoperative	Defective Hoses	Locate and repair
						<b>Climb M2</b> defective	Replace M2
					Altimeter inoperative	Defective Hoses	Locate and repair
<b>Altimeter M1</b> defective	Replace M1						
Excessive Leak	Loose fittings	Locate and repair					
	Defective Hose	Locate and repair					
	Valve V2, V3, V4, V5 or V6 defective	Replace defective valve					
		Instrument M1, M2 or M3 defective	Replace defective Instrument				

## 5.4 Disassembly

### 5.4.1 General

The 377-4 should be disassembled only when repair is necessary. Procedures for disassembly are listed in order from the highest to the lowest subassembly. Disassemble only as far as indicated by the nature of the problem. The order of disassembly can usually be determined by inspection.

#### **WARNING**

Be sure that the power cable is disconnected before disassembling any portion of the equipment.

Mark or otherwise identify all disconnected electrical wiring and pneumatic lines. Make note of color coding, placement of leads, and methods of applying insulation (if any) before disconnecting or removing any electrical part.

### 5.4.2 Removal of Instruments

To remove any of the instruments, remove 3 or 4 mounting screws, Bezel Glass protection and spacers. Grasp instrument, lift out far enough to disconnect hoses and free from panel.

### 5.4.3 Removal of Panel

To remove the panel, remove 12 screws from the perimeter of the panel. Grasp panel and lift up far enough to disconnect pneumatic lines at pump and electrical connection. Lay panel aside for further disassembly.

#### **NOTE**

All components mounted on the panel or in the case are now accessible.

#### **5.4.4 Removal of Valves**

To remove any of the valves, disconnect hoses, remove knob, remove mounting nut, grasp valve and pull free of panel.

#### **5.4.5 Removal of Pump Switch S1**

To remove **pump switch S1**, remove mounting nut and pull switch from panel.

#### **5.4.6 Removal of Capacitor C1**

To remove **Capacitor C1**, remove 2 mounting screws and nuts, disconnect electrical wires and lift free of case.

#### **5.4.7 Removal of Pump VP1**

To remove **Pump VP1**, disconnect all hoses and electrical wires, remove 4 mounting screws and lift pump out of case.

### **5.5 Assembly**

#### **5.5.1 General**

The order of assembly starts with the lowest subassembly and proceeds to the completed equipment.

Before connecting any hoses or electrical connections, refer to the notes of color coding, placement of leads, and wire insulation made during disassembly.

#### **5.5.2 Replacement of Pump VP1**

To replace **Pump VP1**, position the pump over the 4 mounting holes in case. Fasten the pump in place with screws. Connect hoses and electrical lead as noted during disassembly.

#### **5.5.3 Replacement of Capacitor C1**

To replace **Capacitor C1**, position the capacitor over the 2 mounting holes in case. Fasten the capacitor in place with screws and nuts. Connect electrical leads as noted during disassembly.

#### **5.5.4 Replacement of Pump Switch S1**

To replace **Pump Switch S1**, push switch thru hole in panel and fasten with mounting nut. Connect electrical leads as noted during disassembly.

#### **5.5.5 Replacement of Valves**

To replace any of the valves, push valve thru panel and fasten with mounting nut. Replace knob on stem and lock down with set screw. Connect hoses as noted during disassembly.

#### **5.5.6 Replacement of Panel**

To replace the panel, position panel near case and connect hoses and electrical connections as noted during disassembly. Lower panel into case and align each of the 12 mounting holes with the mounting bracket holes. Fasten panel to case with the 12 screws around the perimeter.

#### **5.5.7 Replacement of Instruments**

To replace the instruments, position the instrument near its mounting hole and connect hose as noted during disassembly. Slide instrument into panel and fasten, using spacers, Bezel Glass Protector and screws.

# section **6**

## parts list

SYMBOL	DESCRIPTION	MANUFACTURER'S PART NUMBER	MFR CODE	CASTLEBERRY PART NUMBER	USAGE CODE
	Pitot & Static System Tester	377-4	101	Same	1
	Pitot & Static System Tester	377-4-50K	101	Same	2
	Pitot & Static System Tester	377-4M	101	Same	3
	Pitot & Static System Tester	377-4M-50K	101	Same	4
C1	Capacitor, motor starting	AG331	102		
F1	Fuse	312003	103		
M1	Altimeter	101735-01495	104		1 & 3
M1	Altimeter	A 8A104	104		2 & 4
M2	Climb	7060	105		
M3	Airspeed	EA5173-1	106		1 & 3
M3	Airspeed	F-1	107		2 & 4
S1	Switch	111-16-73	110		
SC1	Bulkhead connector	B-400-71-2	108		
SC2	Bulkhead connector	B-400-71-2	108		
V1	Valve, 4 way	B-43YF2	108		
V2	Valve, Precision Metering	P52-1-12	109		
V3	Valve, Precision Metering	P52-1-12	109		
V4	Valve, Precision Metering	P52-1-11	109		
V5	Valve, Precision Metering	P52-1-11	109		
V6	Valve, Cutoff	B-ORF2-A	108		
V7	Valve, Pressure relief	B-4CPA2-3-DC	108		
VP1	Pump, Vacuum-Pressure	MAA-V111-HB	102		1 & 2

SYMBOL	DESCRIPTION	MANUFACTURER'S PART NUMBER	MFR CODE	CASTLEBERRY PART NUMBER	USAGE CODE
VP1	Pump, Vacuum-Pressure	MAA-V111-HD	102		3 & 4
	Adapter Fitting	B-4-RA-2	108		
	Branch Tree	B-4-BT	108		
	Pipe Plug	B-2-P	108		
	Male Connector	B-400-1-2	108		
	Female Connector	B-400-7-2	108		
	Male Elbow	B-400-2-2	108		
	Male Branch Tee	B-400-3TTM	108		
	Male Run Tee	B-400-3TMT	108		
	Union Cross	B-400-4	108		
	Accessory Pouch			377-FP	
	Power Cord 115v	17405	111		
	Power Cord 220v	15726	111		
	Spacers, Aluminum			8501	
	Bezel Glass Protector			377-D77	
	Bezel Glass Protector			377-D77A	
	Fuse Holder	HMI	112		
	Tubing	44PP	113		

CODE	MANUFACTURER'S NAME
102	G A S T Manufacturing
103	Littlefuse
104	Aerosonic Corp.
105	United Instruments, Inc.
106	Edo-Aire
107	Bendix Corp.
108	Crawford Fitting Company
109	Ideal Aerosmith
110	Carlingswitch
111	Belton
112	Bussmann
113	Gould Imperial-Eastman

# section 7

## specific tests

### 7.1 General

This section presents the procedures for using the 377-4 Pitot and Static System Tester to check specific instruments and Systems.

#### NOTE

It is assumed in this section that the 377-4 Tester has been tested in accordance with paragraph 5.2 and that the master altimeter is within its calibration cycle.

### 7.2 Test Procedure

#### 7.2.1 Test Equipment

The additional test equipment that is required to perform some of the test is listed in Table 7-1. Substitute equipment may be used if equivalent to that listed.

#### 7.2.2 General

The test procedure is presented in Tables 7-2 thru 7-12.

The following paragraphs list the column headings of the test procedure and describes what is included in each column.

##### 7.2.2.2 STEP column

The STEP column lists the number of the test.

##### 7.2.2.3 DESCRIPTION Column

The DESCRIPTION column lists the descriptive name for each test.

##### 7.2.2.4 PROCEDURE Column

The PROCEDURE column lists the procedures that are performed as a part of each test.

##### 7.2.2.5 RESULTS Column

The RESULTS column is used to indicate the required measured output and to describe any noticeable changes that should occur.

### 7.2.3 Bench Tests

#### 7.2.3.1 Altimeter bench test and certification procedures.

The procedures for performing an altimeter bench test and certification is listed in Table 7-2.

#### NOTE

Refer to the appendix section of this manual for copies of FAR 91.170, FAR 43 Appendix E, Sample Altimeter Test Correction Sheet and Advisory Circular AC 43-203B which relate to altimeter test and certification.

Figure 7.1 shows a typical Bench Test setup. Table 7.1 lists any additional test equipment needed to perform test procedures.

TABLE 7-1. Test Equipment Required

EQUIPMENT	MANUFACTURER AND PART NO.	FUNCTION
Transponder and Encoder Tester	IFR Inc. ATC-600A	Test outputs from Transponders and/or Encoding Altimeters.
Test Harness		Provide power input and signal outputs to test equipment or interconnect between remote units.
Stop Watch	Various Mfg. Tested for accuracy	Time leak check and check climb indicator rates.

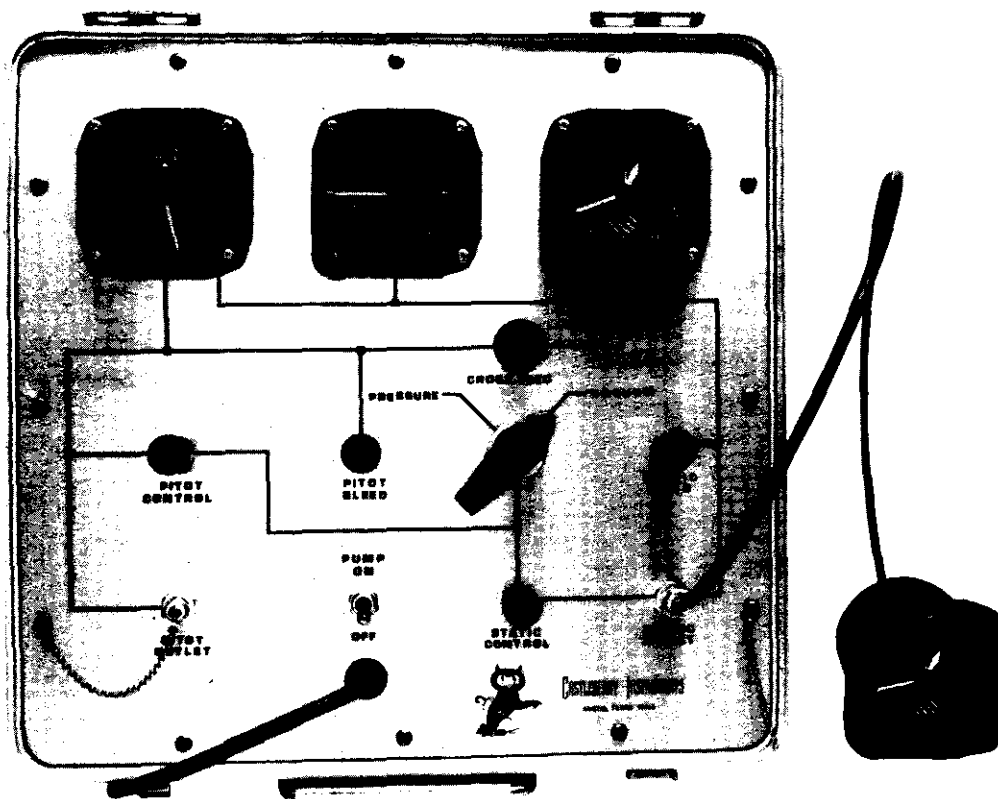

Figure 7.1 Typical Altimeter Bench Test setup

TABLE 7-2. Altimeter Bench Test

STEP	DESCRIPTION	PROCEDURE	RESULT
1	Preliminary Test Setup	<p>Install a test plug in <b>Pitot outlet SC1</b>.</p> <p>Install a male connector and hose to <b>Static outlet SC2</b>. Connect hose to altimeter to be tested.</p> <p>Select "Vacuum" on <b>Vacuum-Pressure Valve V1</b>.</p> <p>Close <b>Pitot and Static control valves V2 &amp; V3</b> fully clockwise.</p> <p>Open <b>Cross Feed Valve V6</b> counterclockwise at least 3 turns.</p> <p>Close <b>Pitot and Static Bleed Valves V4 &amp; V5</b> fully clockwise.</p> <p>Set the barometric scales on Test Box <b>Altimeter M1</b> and test altimeter to 29.92 In. hg. or 1013 MB.</p> <p>Connect power cord to proper power source.</p>	<p>Test altimeter indicates same altitude as master within tolerance allowed for indicated altitude (FAR 43, Appendix E) Table I (Appendix 8-2).</p>
1a	Case Leak Test	<p>Set <b>Pump Switch S1</b> to "ON".</p> <p>Slowly open <b>Static Control valve V2</b> counterclockwise until <b>Climb M2</b> indicates 5,500 feet per min. climb. Maintain approximately 5,500 fpm by adjustment of <b>V2</b> until <b>altimeter M1</b> indicates 18,000 feet.</p>	<p>Audible indication of Tester's pump operating.</p>

TABLE 7-2. Altimeter Bench Test (cont'd)

STEP	DESCRIPTION	PROCEDURE	RESULTS
1a (cont)	Case Leak Test	<p>Close <b>Static Control Valve V2</b> fully clockwise and allow a minute or so for <b>climb M2</b> to stabilize.</p> <p style="text-align: center;"><b>NOTE</b></p> <p>The leakage of tester previously noted in records is subtracted from leakage noted in this step.</p> <p>Slowly open <b>Static Bleed Valve V5</b> counterclockwise until climb indicates 5,500 ft. per min. dive. Maintain 5,500 ft. per min. until altimeter has returned to field elevation and climb reads zero.</p> <p>Set <b>Pump switch S1</b> to "OFF".</p> <p style="text-align: center;"><b>NOTE</b></p> <p>If altimeter under test passed Leak Test then continue. If not, locate cause of leak and repair or reject altimeter.</p>	<p>After <b>Climb M2</b> has stabilized, observe <b>altimeter M1</b> for one minute. Leakage of altimeter under test should not be more than 100 feet.</p>
1b	Scale Error and Friction Test	<p>Select "Pressure" on <b>Vac-Press Valve V1</b>.</p> <p>Close <b>Static Bleed Valve V5</b> fully clockwise.</p> <p>Set <b>Pump switch S1</b> to "ON".</p> <p>Slowly open <b>Static Control Valve V2</b> counterclockwise until <b>climb M2</b> indicates a dive at 3,000 ft. per min. or less until test point is reached using altimeter correction sheet for <b>M1</b>.</p> <p>Use <b>Static Control Valve V2</b> to maintain altitude at each test point for at least one minute, but not more than ten minutes, before taking a reading on altimeter being tested.</p>	<p>Record scale error at each test point. Error shall not exceed tolerances listed in Table I of FAR 43 Appendix E. (Appendix 8-2)</p>



TABLE 7-2. Altimeter Bench Test (cont'd)

STEP	DESCRIPTION	PROCEDURE	RESULT
1b cont.	Scale Error and Friction Test	<p>The Friction test can be made at the same time as the scale error by maintaining a steady rate change of 750 feet per minute and at each testpoint listed in Table III of FAR 43 Appendix E. Record the change in reading of the pointers after vibration.</p>	<p>Record friction error at each test point. Errors shall not exceed Tolerances listed in Table III of FAR 43 Appendix E. (Appendix 8-2)</p>
		<p>After completion of tests below field elevation change <b>Vac-Pressure Valve V1</b> to "Vacuum" and preform test above field elevation to the maximum altitude of the test altimeter.</p>	<p>Record scale error and friction error at each test point.</p>
1c	Hystersis Test	<p><b>NOTE</b>            The hystersis test shall begin not more than fifteen minutes after the altimeters initial exposure to the maximum altitude test point reached during scale error test.</p>	
		<p>Slowly open <b>Static Bleed Valve V5</b> counterclockwise until <b>climb M2</b> indicates a dive rate of 5,500 feet per minute. Maintain 5,500 feet per minute until within 3,000 feet of the first test point (50 per cent of maximum altitude).</p>	
		<p>Decrease rate to 3,000 feet per minute and maintain until test point is reached.</p>	
		<p><b>NOTE</b>            Refer to altimeter correction sheet for <b>Master Altimeter M1</b> and use the "DOWN" readings for Hystersis test.</p>	

TABLE 7-2. Altimeter Bench Test (cont'd)

STEP	DESCRIPTION	PROCEDURE	RESULT
1c cont.	Hysteresis Test	<p>The altimeter shall be kept at this test point for at least 5 minutes, but not more than 15 minutes, before taking a reading on altimeter under test.</p> <p>Open <b>Static Bleed</b> to further decrease altitude to second test point (40 per cent of maximum altitude).</p> <p>Hold this altitude for at least 1 minute but not more than 10 minutes before taking reading.</p> <p>Open <b>Static Bleed</b> and allow system to return to field elevation at the 5,500 feet per minute rate.</p>	<p>Record Hysteresis Test reading. (50%)</p> <p>Record Hysteresis Test reading. (40%)</p> <p>The readings recorded for either of the two test points shall not differ by more than the tolerance in FAR 43 Appendix E Table II from the reading of the test altimeter for the same altitude recorded in the scale error test.</p>
1d	After Effects Test	<p>Not more than 5 minutes after the completion of the Hysteresis Test the reading of the altimeter under test shall not differ from the original field elevation reading by more than 30 feet.</p> <p><b>NOTE</b>            Correct altimeters for any atmospheric pressure change before taking reading.</p> <p>Set <b>Pump Switch S1</b> to "OFF".</p> <p>Disconnect hose on altimeter tested.</p>	Record After Effects readings

TABLE 7-2. Altimeter Bench Test (cont'd)

STEP	DESCRIPTION	PROCEDURE	RESULT
1e	Barometric Scale Error Check	At constant atmospheric pressure, set the barometric scale on the test altimeter to each of the pressures listed in FAR 43 Appendix E Table IV which shall cause the altimeter's pointer to indicate the equivalent altitude difference at each pressure listed within a tolerance of 25 feet.	Record Barometric scale error.
1f	Certification and Paper Work	If the altimeter tested passed all the tests, record on the altimeter's case the <b>date</b> of the test and the <b>maximum</b> altitude tested. A copy of the test readings recorded shall be kept on file by the person or repair station performing these tests.	Refer to Appendix 8-5 for proper record entry.

7.2.3.2 Encoding Altimeter Bench Test

**NOTE**

The procedure for performing an Encoding Altimeter Bench Test and certification is listed in Table 7-3.

Refer to the appendix section of this manual for copies of FAR 91.170, 91.177, 91.36, 43 Appendix E & F, AC 43.203B and AC 43.6A.

Figure 7.2 shows a typical Bench Test setup. Refer to Table 7-1 for additional test equipment needed to perform test procedures.

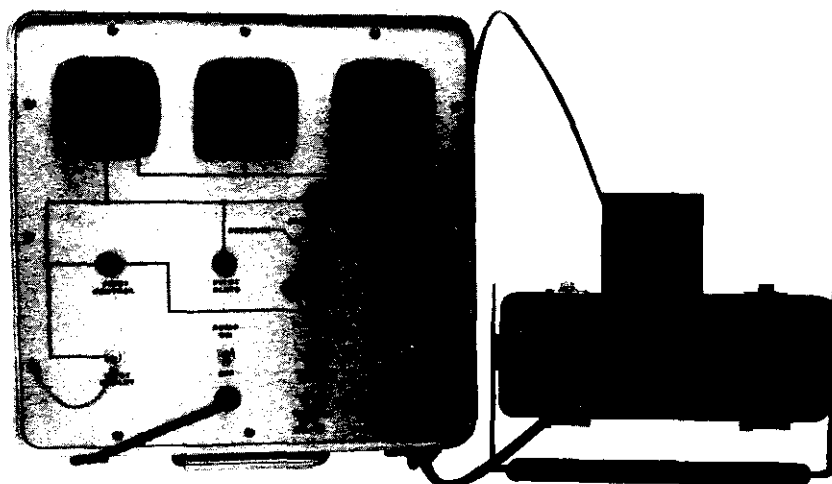

Figure 7.2 Typical Encoding Altimeter Bench Test setup

TABLE 7-3. Encoding Altimeter Bench Test

STEP	DESCRIPTION	PROCEDURE	RESULT
2	Preliminary Test Setup	<p>Same as Step 1, Table 7-2 except as follows:</p> <p>Connect test cable between encoder and encoder test box/or transponder. Refer to manual that covers the encoder test box or make of transponder for power requirements and operation.</p>	
2a	Case Leak Test	<p>Same as Step 1a, Table 7-2 with the exceptions as follows:</p> <p>If encoder being tested is of the Servoed type or has an internal vibrator, apply the proper power; through the test cable during leak test.</p>	
2b	Scale Error, Friction and Data Correspondence	<p>Same as step 1b, Table 7-2 for scale error and friction test.</p> <p>Data correspondence test as required by FAR 91.36 (b) can be performed while performing Scale Error and Friction test.</p> <p>Refer to advisory Circular 43-6A paragraph 8 and note the test point altitudes called out in Tables 1 or 2. (Appendix 8-12)</p> <p>Approach each test point slowly, decreasing pressure for increasing altitude and vice versa, until a transition to the test point value occurs on the encoder test box.</p>	Record the encoding altimeter's reading at the instant of transition.
2c	Hysteresis Test	Same as Step 1c, Table 7-2.	
2d	After Effects Test	Same as Step 1d, Table 7-2.	
2e	Barometric Scale Error Check	Same as Step 1e, Table 7-2.	
2f	Certification and Paper Work	Same as Step 1f, Table 7-2.	

### 7.2.3.3 Airspeed Indicator Bench Test

The procedure for performing an Airspeed Indicator bench test is listed in Table 7-4.

**NOTE**

Refer to the appendix section of this manual for copies

of FAR 37.112 (TSO-C2b) and Aeronautical Standard AS391C for error tolerances.

Figure 7.3 shows a typical Bench Test setup. Refer to Table 7-1 for additional test equipment needed to perform test procedures.

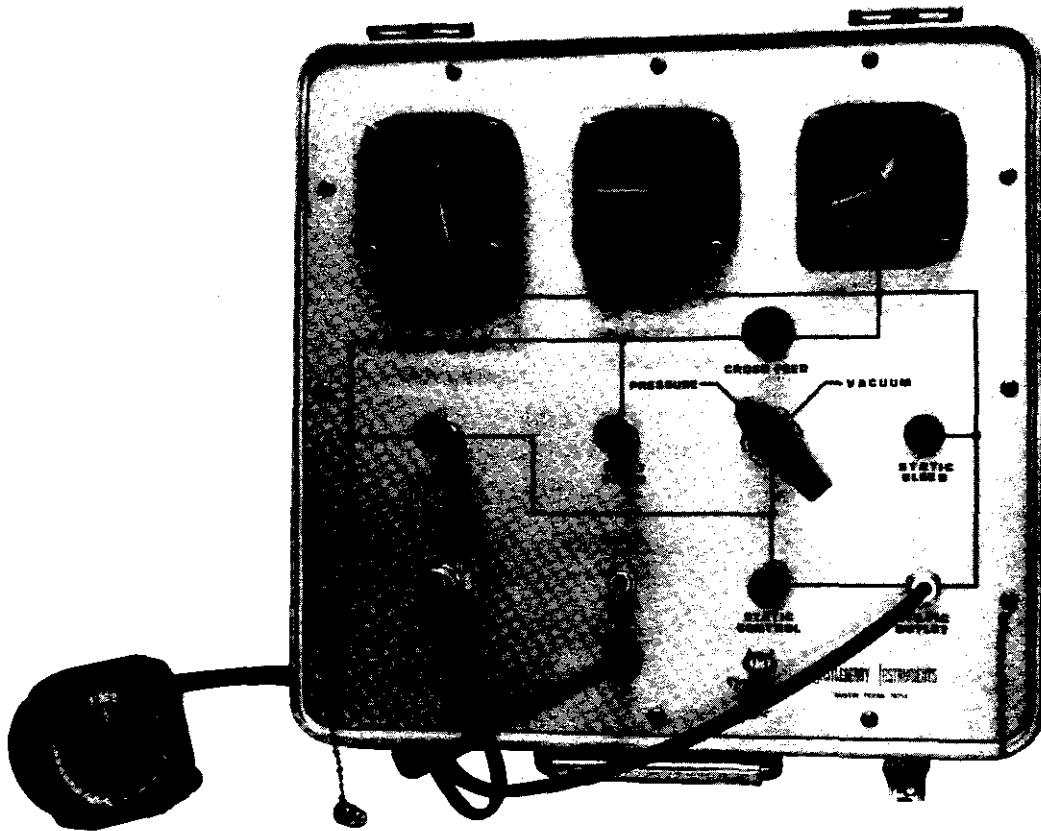

Figure 7.3 Typical Airspeed Indicator Bench Test setup

TABLE 7-4. Airspeed Bench Test

STEP	DESCRIPTION	PROCEDURE	RESULT
3	Preliminary Test Setup	<p>Install male connectors into both <b>Pitot and Static outlet connections SC1 &amp; SC2.</b></p> <p>Install male connectors into Pitot and Static ports of airspeed to be tested.</p> <p>Connect hoses from airspeed to test box.</p> <p>Select "Vacuum" on <b>Vacuum-pressure valve V1.</b></p> <p>Close <b>Pitot and Static control valve V2 &amp; V3</b> fully clockwise.</p> <p>Open <b>cross feed valve V6</b> counterclockwise at least 3 turns.</p> <p>Close <b>Pitot and Static Bleed valves V4 &amp; V5</b> fully clockwise.</p> <p>Connect testers power cord to proper power source.</p>	
3a	Case Leak Test	<p>Set <b>pump switch S1</b> to "ON".</p> <p>Slowly open <b>static control valve V2</b> counterclockwise until <b>climb M2</b> indicates 5,500 feet per minute climb rate.</p> <p>Maintain 5,500 feet per minute by adjustment of V2 until <b>altimeter M1</b> indicates 18,000 feet.</p> <p>Close <b>static control valve V2</b> fully clockwise and allow a minute or so for <b>climb M2</b> to stabilize.</p> <p><b>NOTE</b></p> <p>The leakage of tester as previously recorded shall be subtracted from valve noted in this step.</p>	<p>Audible indications of pump running.</p> <p>After <b>climb M2</b> has stabilized observe <b>altimeter M1</b> for one minute. Leakage of airspeed should not be more than 100 feet per minute.</p>

TABLE 7-4. Airspeed Bench Test (cont'd)

STEP	DESCRIPTION	PROCEDURE	RESULT
3a cont.	Case Leak Test cont'd	<p>Slowly open <b>static bleed valve V5</b> counterclockwise until <b>climb M2</b> indicates 5,500 feet per minute dive. Maintain dive rate until <b>altimeter M1</b> reads field elevation and <b>climb M2</b> reads zero.</p> <p>Set <b>pump switch S1</b> to "OFF".</p> <p style="text-align: center;"><b>NOTE</b></p> <p>If the airspeed has passed leak test then continue to scale error test. If not, locate cause of leak and repair or reject airspeed.</p>	
3b	Scale Error and Friction Test	<p>Select "Pressure" on <b>Vacuum-pressure valve V1</b>.</p> <p>Open <b>static bleed valve V5</b> counterclockwise at least 3 turns.</p> <p>Close <b>cross feed valve V6</b> fully clockwise.</p> <p>Set <b>pump switch S1</b> to "ON".</p> <p>Slowly open <b>Pitot control valve V3</b> while observing <b>airspeed M3</b> and its correction sheet. Adjust <b>V3</b> as necessary to set each test point.</p> <p>Friction error is the amount of change the pointer moves after vibration.</p> <p>Scale error reading is taken after vibration.</p> <p>After completion of final test point, close <b>Pitot control V3</b> fully clockwise.</p> <p>Slowly open <b>Pitot bleed V4</b> and allow <b>airspeed M3</b> and tested airspeed to return to zero or rest position.</p>	<p>Audible indications of pump running.</p> <p>Record scale error and friction for each test point. Scale error and friction shall not exceed tolerance listed in Table II &amp; III of Aeronautical Standard AS391C or manufacturer's Specs for standard airspeeds. For maximum allowable and mach type airspeeds refer to FAR 37.145 (TSO-C46a) Tables I &amp; II. (Appendixes 8-14, -15, and -18)</p>

TABLE 7-4. Airspeed Bench Test (cont'd)

STEP	DESCRIPTION	PROCEDURE	RESULT
3b	Scale Error and Friction Test (cont'd)	Set <b>pump switch S1</b> to "OFF".  Disconnect hoses and remove fitting from tested airspeed.	
3c	Paper Work	If the airspeed tested passed all tests, file a copy of test reading recorded by serial no., part no. and date of test.	Refer to Appendix 8-5 for proper record entry.

**7.2.3.4 Climb Indicator Bench Test**

The procedure for performing a Climb Indicator bench test is listed in Table 7-5.

Figure 7.4 shows a typical bench test setup. Table 7-1 lists any additional test equipment needed to perform test procedures.

**NOTE**

Refer to the appendix section of this manual for copies of FAR 37.118 f(TSO-C8b) and Aeronautical Standard AS 394A.

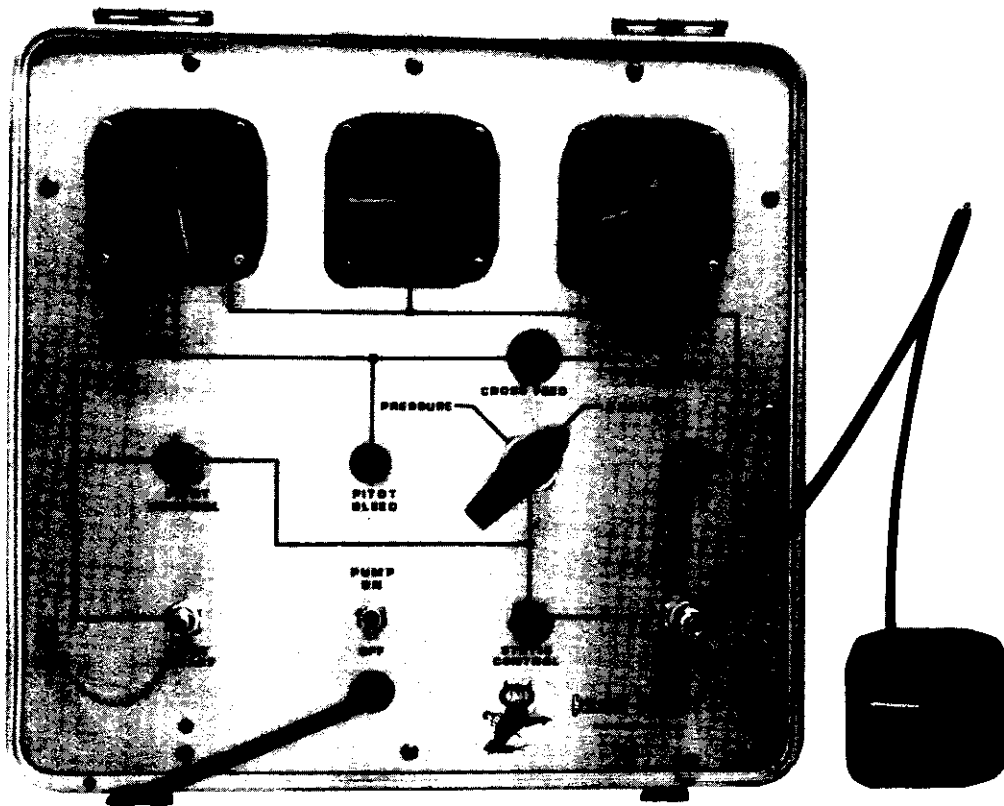

Figure 7.4 Typical Climb Indicator Bench Test setup



TABLE 7-5. *Climb Indicator Bench Test*

STEP	DESCRIPTION	PROCEDURE	RESULT
4	Preliminary Test Setup	<p>Same as Step 1, Table 7-2 except connect hose to climb indicator.</p> <p>Check that both tester's climb and the one to be tested have the pointer exactly on zero.</p> <p>If not on zero, adjustment can be made on most makes by using a small screwdriver on the zero adjustment located either at the lower left or right of the front of the instrument.</p>	
4a	Case Leak Check	<p>Same as Step 1a, Table 7-2 except when setting the climb or dive rate do not exceed the maximum indication of the climb being tested.</p> <p style="text-align: center;"><b>NOTE</b></p> <p>If the climb passed leak test then continue to perform scale error test, if not, locate cause of leak and repair or reject climb.</p>	<p>Leakage of climb shall not exceed 100 feet at 18,000 feet as observed on <b>altimeter M1</b> for one minute.</p>
4b	Scale Error Test	<p>Select "Vacuum" on <b>Vac-Press valve V1</b>. Close <b>Static bleed valve V5</b> fully clockwise.</p> <p>Set <b>Pump switch S1</b> to "ON".</p> <p>Slowly open <b>static control valve V2</b> counterclockwise while observing climb under test.</p> <p>Check each of the test points listed in Table I of the Aeronautical Standard AS394A using a stop watch and the tester's altimeter <b>M1</b>.</p>	<p>Record scale error reading at each test point. Error shall not exceed tolerances listed in Table I of AS394A or Manufacturers Specs. (Appendixes 8-16 &amp; -17)</p>

TABLE 7-5. *Climb Indicator Bench Test (cont'd)*

STEP	DESCRIPTION	PROCEDURE	RESULT
4b	Scale Error Test (cont'd)	<p>Adjust <b>static control valve V2</b> to set ascent rate and <b>static bleed valve V5</b> to set the descent rate on the climb being tested. While maintaining the exact rate, check the time required for the testers altimeter to change altitude for the value of feet set.</p> <p>To convert the tolerance values from feet per minute to seconds, divide the tolerance value by the test rate, then multiply the answer by 60.</p> <p style="text-align: center;">Sample</p> <p>(Tolerance)      (Test Rate)            100 FPM ÷ 500 FPM = 0.2            0.2 × 60 = 12 seconds</p> <p>After completion of last test point, slowly open <b>static bleed valve V5</b> to let tester and climb return to atmospheric pressure.</p> <p>Set <b>pump switch S1</b> to "OFF".</p> <p>Disconnect hoses and remove fitting from climb indicator.</p>	<p>Refer to Appendix 8-5 for proper entry.</p>
4c	Paper Work	<p>If the climb tested passed all tests, file a copy of test readings recorded by serial no., part no, and date of test.</p>	<p>Refer to Appendix 8-5 for proper entry.</p>

**7.2.3.5 Air Data Computer Bench Test (Bench Test of Air Data Computers and Static Defect Correction Module Computers)**

The procedure for performing an Air Data Computer bench test is listed in Table 7-6.

Refer to Table 7-1 for additional test equipment needed to perform test procedures.

If the air data system has a reverting altimeter (Baro-Servo) it shall be tested for compliance with FAR 91.170 and 43 Appendix E. See Tables 7-2 Altimeter Bench Test for test procedure.

**NOTE**

Refer to the manufacturer's test procedures, test points, specifications and tolerances for each computer to be tested and fabrication data for test harness.

TABLE 7-6. Air Data Computer Bench Test

STEP	DESCRIPTION	PROCEDURE	RESULT
5	Preliminary Setup	<p>Remove test plug from outlet connectors and install male connector.</p> <p>Connect hose from Pitot and Static outlets to the pitot and static ports of computer and indicator if required.</p> <p>Select "Vacuum" on <b>Vac-Press valve V1</b>.</p> <p>Close <b>Pitot and Static control valves V2 &amp; V3</b> fully clockwise.</p> <p>Open <b>cross feed valve V6</b> counterclockwise at least 3 turns.</p> <p>Close <b>Pitot and Static bleed valve V4 &amp; V5</b> fully clockwise.</p> <p>Set Barometric scales on tester's <b>altimeter M1</b> to 29.92 In. Hg.</p> <p>Connect tester's power cord to proper power source.</p>	

TABLE 7-6. Air Data Computer Bench Test (cont'd)

STEP	DESCRIPTION	PROCEDURE	RESULT
5a	Case Leak Test	<p>Connect test harness for computer. Also connect the proper power source and it test equipment or remote indicator.</p> <p>Set <b>pump switch S1</b> to "ON"</p> <p>Slowly open <b>Static Control valve V2</b> counterclockwise until <b>climb M2</b> indicates 5,500 feet per minute climb or the rate recommended by manufacturer of computer.</p> <p>Maintain 5,500 feet per min. by adjustment of <b>static control valve V2</b> until <b>altimeter M1</b> indicates 18,000 feet.</p> <p>Close <b>Static Control valve V2</b> fully clockwise, allow a minute or so for <b>Climb M2</b> to stabilize.</p> <p><b>NOTE</b></p> <p>The leakage of the tester previously noted in records shall be subtracted from the leakage noted in this step.</p> <p>Slowly open <b>static bleed valve V5</b> counterclockwise until <b>climb M2</b> indicates 5,500 feet per minute dive. Maintain 5,500 feet per min. until <b>altimeter M1</b> has returned to field elevation and <b>climb M2</b> indicates zero feet per minute.</p> <p>Set <b>pump switch S1</b> to "OFF".</p> <p><b>NOTE</b></p> <p>If computer under test passed the leak test then continue to next test. If not then locate cause of leak and repair or reject computer.</p>	<p>Audible indication of tester's pump operating.</p> <p>After <b>climb M2</b> has stabilized observe <b>altimeter M1</b> for one minute. Leakage of computer should not be more than 100 feet.</p>

TABLE 7-6. Air Data Computer Bench Test (cont'd)

STEP	DESCRIPTION	PROCEDURE	RESULT
5b	Static Source Error Correction Test	<p>Select "Pressure" on <b>Vac-Press Valve V1</b>.</p> <p>Close <b>Static bleed valve V5</b> fully clockwise.</p> <p>Set <b>pump switch S1</b> to "ON".</p> <p>Slowly open <b>static control valve V2</b> counterclockwise. <b>Climb M2</b> should indicate a dive and <b>altimeter M1</b> should indicate a descent in altitude.</p> <p>Adjust <b>static control V2</b> until <b>altimeter M1</b> indicates 0 altitude and <b>climb M2</b> is stabilized on zero.</p> <p>Close <b>cross feed valve V6</b> fully clockwise.</p> <p>Slowly open <b>pitot control valve V3</b> counterclockwise. <b>Airspeed M3</b> should indicate increase in airspeed.</p> <p>Adjust <b>pitot control V3</b> to obtain each airspeed test point for 0 altitude as required by computer or airframe manufacturer.</p> <p>Close <b>pitot control V3</b> fully clockwise after final airspeed test point has been made.</p> <p>Slowly open <b>pitot bleed valve V4</b> counterclockwise and allow airspeed to decrease to almost zero.</p> <p>Close <b>pitot bleed valve V4</b> fully clockwise.</p> <p>Open <b>cross feed valve V6</b> at least 3 turns counterclockwise.</p>	<p>Refer to manufacturer's specifications for value and tolerance of correction factors</p>

TABLE 7-6. Air Data Computer Bench Test (cont'd)

STEP	DESCRIPTION	PROCEDURE	RESULT
5b	Static Source Error Correction Test (cont'd)	<p><b>NOTE</b></p> <p>Airspeed should have decreased completely to zero and <b>climb M2</b> and <b>altimeter M1</b> should indicate a slight decent momentarily.</p>	
5b1		Select "Vacuum" on <b>Vac-Press valve V1</b> .	
5b2		Slowly open <b>static control valve V2</b> counterclockwise and adjust to obtain up to maximum climb rate recommended by manufacturer until next test altitude is reached.	
5b3		Close <b>static control V2</b> fully clockwise.	
5b4		Close <b>cross feed valve V6</b> fully clockwise.	
5b5		Select "Pressure" with <b>Vac-Press, valve V1</b> .	
5b6		<p>Slowly open and adjust <b>Pitot control valve V3</b> to obtain each airspeed test point required.</p> <p>After airspeed test have been made at this altitude.</p>	Record test readings taken for each test point.
5b7		<p>Slowly open <b>cross feed valve V6</b> counterclockwise. <b>Airspeed M3</b> shall decrease to zero and <b>climb M2</b> and <b>altimeter M1</b> will indicate a descent until airspeed decreased to zero. Continue to open cross feed at least 3 turns.</p> <p>Select "Vacuum" with <b>Vac-Press, valve V1</b>.</p>	

TABLE 7-6. Air Data Computer Bench Test (cont'd)

STEP	DESCRIPTION	PROCEDURE	RESULT
5b	Static Source Error Correction Test (cont'd)	<p>Airspeed test for each altitude required by manufacturer may be made by repeating procedures 5b1 thru 5b7.</p> <p>After maximum altitude air-speed test have been made return tester to field elevation pressure as follows:</p> <p>Open <b>cross feed valve V6</b> at least 3 turns counterclockwise.</p> <p>Slowly open <b>static bleed valve V5</b> counterclockwise and adjust as necessary to maintain climb descent rate recommended by manufacturer until field elevation is reached and <b>climb M2</b> returns to zero.</p> <p>Set <b>pump switch S1</b> to "OFF".</p> <p>Disconnect hoses and remove test fittings.</p>	
5c	Certification and Paper Work	<p>If the Air Data Computer has passed all the tests, record on the case of the tested unit the date of the test and the maximum altitude to which it was tested. A copy of the test readings recorded shall be kept on file by the person or repair station performing the test.</p>	

## 7.2.4 Ramp Tests

### 7.2.4.1 Static System Leak Test (unpressurized aircraft)

The procedure for performing a static systems leak check on unpressurized aircraft is listed in Table 7-7.

### NOTE

Refer to the appendix section of this manual for copies of FAR 91.170, 43 Appendix E, 23.1325, 25.1325, Advisory Circulars AC 43-203B and 43.13-1 change 2.

Figure 7.5 shows a typical ramp test setup.

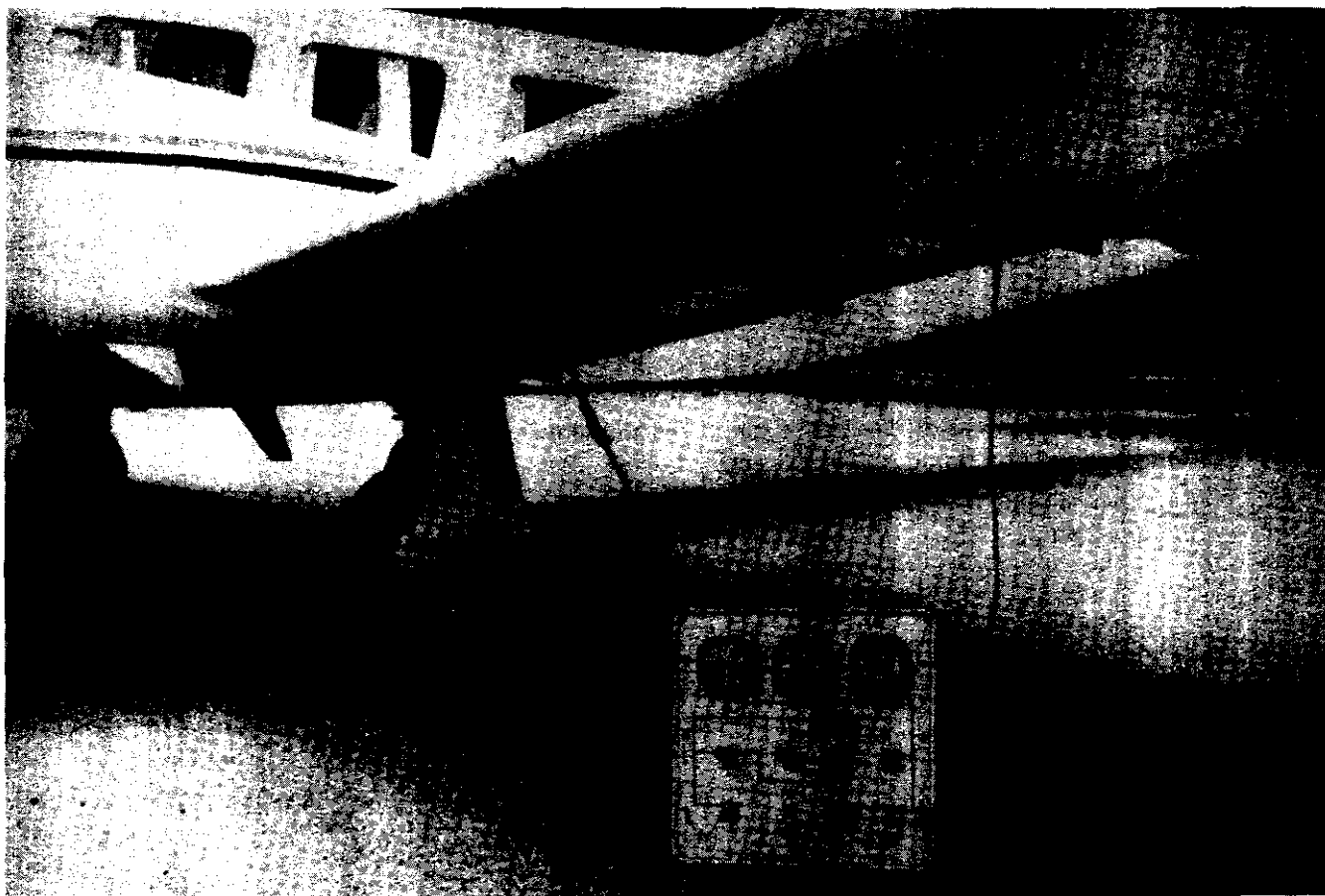

Figure 7.5 Typical ramp test setup for Static System Leak Test for Unpressurized aircraft



TABLE 7-7. Static System Leak Test (Unpressurized Aircraft)

STEP	DESCRIPTION	PROCEDURE	RESULT
6	Preliminary Test Setup	<p>Refer to paragraphs A1, 2, 3 &amp; 4 of FAR 43 Appendix E and 5a-c of AC 43-203B. (Appendix 8-2 &amp; 8-11)</p> <p>Install a test plug in <b>pitot outlet SC1</b>.</p> <p>Install a male connector into <b>static outlet SC2</b>.</p> <p>Connect a hose from <b>static outlet SC2</b> directly to the static ports if practicable. Make sure that connection is secure so that it cannot come loose during testing.</p> <p>Seal alternate static port with an over-size piece of non-porous tape.</p> <p>Select "Vacuum" on <b>Vac-Press valve V1</b>.</p> <p>Close <b>pitot and static control valves V2 &amp; V3</b> fully clockwise. Close <b>cross feed valve V6</b> fully clockwise.</p> <p>Open <b>pitot bleed valve V4</b> at least 3 turns counter-clockwise.</p> <p>Close <b>static bleed valve V5</b> fully clockwise.</p> <p>Connect tester's power cord to a proper power source.</p>	
6a	Leak Check	Set <b>pump switch S1</b> to "ON".	Audible indication of tester's pump operating.

TABLE 7-7. Static System Leak Test (Unpressurized Aircraft) (cont'd)

STEP	DESCRIPTION	PROCEDURE	RESULT
6a	Leak Check (cont'd)	<p>Slowly open <b>static control valve V2</b> counterclockwise while observing climb indicator in aircraft. Do not exceed its rate of climb. When <b>altimeter M1</b> indicates 1,000 feet above field elevation close static control <b>valve V2</b> fully clockwise.</p>	<p>After system has stabilized for a minute or so observe <b>altimeter M1</b> for one minute. Leakage shall not exceed 100 feet in one minute.</p>
		<p>Slowly open <b>static bleed valve V5</b> counterclockwise while observing climb indicator in aircraft. Do not exceed its rate of descent. Control descent rate with <b>static bleed V5</b> until system has returned to field elevation.</p>	
		<p>Set <b>pump switch S1</b> to "OFF".</p>	
		<p><b>NOTE</b></p>	
		<p>If static system of aircraft passed leak check, record date of test in the aircraft's log book. If leak was excessive locate cause of leak and repair or replace defective component or hardware, then retest system.</p>	<p>Refer to Appendix 8-5 for proper records entry.</p>
		<p>Disconnect hose from static port and REMOVE tape from alternate port.</p>	

### 7.2.4.2 Airspeed and Pitot System Test

The procedure for performing an airspeed and pitot system test are listed in Table 7-8.

**NOTE**

Refer to the appendix section of this manual for copies

of FAR 37 (TSO-C2b), Aeronautical Standard AS 391C and Advisory Circular AC 43.13-1 change 2.

Figure 7.6 shows a typical ramp test setup.



Figure 7.6 Typical ramp test setup for Airspeed and Pitot System Test

TABLE 7-8. *Airspeed and Pitot System Test*

STEP	DESCRIPTION	PROCEDURE	RESULT
7	Preliminary Test Setup	<p>Install a male connector into the <b>pitot outlet SC1</b>.</p> <p>Connect a hose from pitot outlet to the pitot tube on the aircraft using the necessary adapter.</p> <p>Select "Pressure" on <b>Vac-Press, valve V1</b>.</p> <p>Close <b>pitot and static control valves V2 &amp; V3</b> fully clockwise.</p> <p>Close <b>cross feed valve V6</b> fully clockwise.</p> <p>Open <b>static bleed valve V5</b> at least 3 turns.</p> <p>Close <b>pitot bleed valve V4</b> fully clockwise.</p> <p>Connect tester's power cord to proper power source.</p>	
7a	Scale Error and Friction Test	<p>Set <b>pump switch S1</b> to "ON".</p> <p>Slowly open <b>pitot control valve V3</b> while observing <b>airspeed M3</b> and its correction sheet. Adjust pitot control as necessary to set pressure for each test point.</p> <p>Friction error is the amount of change the pointer moves after vibration.</p> <p>Scale error reading is taken after vibration.</p> <p>After maximum airspeed test point is reached, close <b>pitot control V3</b> fully clockwise.</p>	<p>Audible indication of pump running.</p> <p>Record scale error and friction for each test point. Refer to Appendix 8-14 &amp; -15 for tolerances.</p>

TABLE 7-8. *Airspeed and Pitot System Test (cont'd)*

STEP	DESCRIPTION	PROCEDURE	RESULT
7b	Pitot System Leak Check	Observe airspeed for a minute while at maximum airspeed indication.	Record leakage of pitot system. Refer to Appendix 8-14 & -15 for tolerance.
7c	Pitot Heater Check	<p>Slowly open <b>pitot bleed valve V4</b> and allow all pressure to bleed off.</p> <p>Set <b>Pump Switch S1</b> to "OFF". Disconnect hose and adapter from pitot tube.</p> <p>Turn on aircraft's master switch and while observing ampmeter turn on pitot heat switch only long enough to see ampere increase.</p> <p>Turn off master switch.</p>	
7d	Paper Work	Record date of test in aircraft's log books.	Refer to Appendix 8-5 for proper records entry.

### 7.2.4.3 Static System Leak Test (Pressurized Aircraft)

The procedures for performing a Static Leak Test on a pressurized type aircraft is listed in Table 7-9.

#### NOTE

Refer to the appendix section of this manual for copies of FAR's 91.170, 43 Appendix E, 23.1325, 25.1325, Advisory Circulars AC 43-203B, 41.13-1 change 2 and Table 8-4 Maximum Cabin Differential Test Pressure versus Test Altitude.

Figure 7.7 shows a typical ramp test setup.

#### PRECAUTIONS

Before any static system is tested, it should be determined that the design limits of instruments attached to it will not be exceeded during test. To determine

this, it is necessary to locate and identify all instruments attached to the system. In addition to the altimeter, airspeed and rate of climb, many aircraft use static pressure for the operation of autopilots, flight recorders, air data computers, altitude reporting digitizers, etc. The use of a static system diagram of the aircraft involved may be helpful in locating all of the instruments. If a diagram is not available, the instruments can be located by tracing the physical installation.

Damage can occur to instruments that are connected to both the static system and pitot system when only the static system is evacuated. The maximum design differential pressure of these instruments may be exceeded. One method to prevent this type of damage is to tie both the pitot and static systems together when conducting static system checks. This should result in zero differential pressure regardless of the degree of static system evacuation. It should be noted that a leak in either system will be indicated on the test set.



Figure 7.7 Typical ramp test setup for Static System Leak Test for pressurized aircraft

TABLE 7-9. Static System Leak Test (Pressurized Aircraft)

STEP	DESCRIPTION	PROCEDURE	RESULT
8	Preliminary Test Setup	<p>Refer to paragraphs dl-4 of FAR43 Apendix E and 5a-f of AC 43-203B. (Appendix 8-2 and 8-11)</p> <p>Install male connectors into both the <b>pitot and static outlets SC1 &amp; SC2.</b></p> <p>Connect a hose from <b>static outlet SC2</b> directly to one of the static ports on the aircraft.</p> <p>Connect a hose from <b>pitot port outlet SC1</b> directly to pitot tube on aircraft.</p> <p><b>NOTE</b></p> <p>Use the adapter as necessary to make secure connections to the ports on the aircraft.</p> <p>Seal alternate static port and drain hole on pitot tube with oversize pieces of non-porous tape.</p> <p>Select "Vacuum" on <b>Vac-Press. valve V1.</b></p> <p>Close <b>pitot and static control valve V2 &amp; V3</b> fully clockwise.</p> <p>Open <b>cross feed valve V6</b> counterclockwise at least three turns.</p> <p>Close <b>pitot and static bleed valves V4 &amp; V5</b> fully clockwise.</p> <p>Connect test box power cord to a proper power source.</p>	

TABLE 7-9. Static Systems Leak Test (Pressurized Aircraft) (cont'd)

STEP	DESCRIPTION	PROCEDURE	RESULT
8a	Leak Check	<p>Set <b>pump switch S1</b> to "ON".</p> <p>Slowly open <b>static control valve V2</b> counterclockwise while observing the climb indicator in the aircraft. Do not exceed its maximum rate of climb.</p> <p>When <b>altimeter M1</b> indicates the test altitude that is equal to the maximum cabin differential pressure, close <b>static control valve V2</b> fully clockwise.</p> <p>Slowly open <b>static bleed valve V5</b> counterclockwise while observing the climb indicator in the aircraft. Do not exceed its maximum rate of descent.</p> <p>Adjust <b>static bleed valve V5</b> to control descent rate until system has returned to field elevation.</p> <p>Set <b>pump switch S1</b> to "OFF".</p>	<p>Audible indication of pump operation.</p> <p>After allowing a minute or so for system to stabilize observe altimeter M1 for one minute. Leakage shall not exceed 2 percent of test altitude or 100 feet whichever is greater.</p>
		<p>Disconnect hoses from aircraft and REMOVE tape from alternate static port and pitot drain.</p>	<p>Record date of test in aircraft's log books. Refer to Appendix 8-5 for proper records entry.</p>



#### 7.2.4.4 Altimeter Test and Certification

The procedure for performing an altimeter test and certification as required by FAR 91.170 while the altimeter is still in the aircraft is listed in Table 7-10.

#### **NOTE**

Refer to the appendix section of this manual for copies of FAR's 91.170, 43 Appendix E, 23.1325,

25.1325, Advisory Circulars AC 43-203B and 43.13-1 change 2.

Because of the complexity of the altimeter test, whenever practical, remove the altimeter from the aircraft and test per altimeter bench test procedures paragraph 7.2.3.1.

Figure 7.8 shows a typical test setup.



Figure 7.8 Typical ramp test setup for Altimeter Test and Certification

TABLE 7-10. Altimeter Test and Certification

STEP	DESCRIPTION	PROCEDURE	RESULT
9	Preliminary Test Setup	Same as Altimeter Bench Test Table 7-2 except as follows:  Install male connectors into both <b>pitot and static outlets SC1 &amp; SC2</b> .  Connect hoses from outlets to the static port and pitot tube of the aircraft.  Seal alternate static port and drain hole on pitot tube with oversized pieces of non-porous tape.	
9a	Scale Error and Friction Test	Same as Step b, Table 7-2.  <b>Caution</b> Do not exceed the limits of the climb indicator in the aircraft.	
9b	Hysteresis Test	Same as Step 1c, Table 7-2.	
9c	After Effects Test	Same as Step 1d, Table 7-2.	
9d	Barometric Scale Error Test	Same as Step 1e, Table 7-2.	
9e	Paper Work and Certification	Same As Step 1f, Table 7-2. Plus: Make an entry into aircraft log books, per sample in AC 43-203B, paragraph 8. (1) & (2). (Appendix 8-11).	

#### 7.2.4.5 Data Correspondence Test

The procedure for performing a data correspondence test between automatically reported pressure altitude data and the pilot's altitude reference as required by FAR 91.36 is listed in Table 7-11.

Refer to Table 7-1 for transponder test equipment required for test.

Figure 7.9 shows a typical test setup.

#### **NOTE**

Refer to the appendix section of this manual for copies of FAR 91.36 and Advisory Circular AC 43-6A.



Figure 7.9 Typical ramp test setup for Data Correspondence Test

TABLE 7-11. Data Correspondence Test

STEP	DESCRIPTION	PROCEDURE	RESULT
10	Preliminary Test Setup	<p>Same as Step 9, Table 7-10.                      Plus:                      Setup transponder tester as recommended by manufacturer.</p>	
		<p style="text-align: center;"><b>NOTE</b></p> <p>Refer to AC 43-6A, paragraph 8b (1)-(4). (Appendix 8-12)</p>	
10a	Correspondence Test	<p>Set <b>pump switch S1</b> to "ON".</p> <p>Slowly open static <b>control valve V2</b> while observing climb indicator in aircraft. Do not exceed its limits.</p> <p>Adjust <b>static control valve V2</b> or <b>static bleed valve V5</b> to set each of the test points called out in Table 1 or 2 of AC43-6A. (Appendix 8-12)</p> <p>Return system to field elevation by slowly opening <b>static bleed valve V5</b> while observing climb indicator in aircraft. Do not exceed its limits.</p> <p>After systems have returned to field elevation, turn <b>pump switch S1</b> to "OFF".</p> <p>Shut down transponder test and turn off aircraft transponder and master switch.</p>	<p>Observe pilot's altimeter and transponder test set. The encoded output data as observed on transponder test set shall correspond within 125 feet of the Pilot's altimeter for each test point.</p>

TABLE 7-11. *Data Correspondence Test (cont'd)*

STEP	DESCRIPTION	PROCEDURE	RESULT
10a	Correspondence Test (cont'd)	Disconnect hoses from aircraft's static port and pitot tube.  Remove tape from alternate static port and pitot drains.	
10b	Paper Work	Record of test shall be recorded in the aircraft's log book in accordance with FAR 43.9. (Appendix 8-5)	

**7.2.4.6 Air Data Computer Test**

The procedure for performing an air data computer test to comply with FAR 91.170 and 43 Appendix E is listed in Table 7-12.

Additional data is also required that provides test data on make of air data computer and/or aircraft make and model.

**NOTE**

Refer to the appendix sections of this manual for copies of FAR 91.170 and 43 Appendix E.

TABLE 7-12. Air Data Computer Test

STEP	DESCRIPTION	PROCEDURE	RESULT
11	Preliminary Test Setup	<p>Disconnect the pitot and static lines from the air data computer.</p> <p>Connect a pitot and static line from <b>test set outlets SCI &amp; SC2</b> to the air data computer.</p> <p><b>NOTE</b></p> <p>If a reverting altimeter (Baro-Servo) is used on the aircraft, the static line from the test set must also be connected to the altimeter. A tee fitting will allow connections to the reverting altimeter, air data computer and test set.</p> <p>Apply power to the air data system. When the altimeter flag is out of view, set 29.92 In. Hg. or 1013MB on the altimeter using the BARO set knob.</p> <p>Set altimeter in test set to 29.92 In. Hg.</p>	
11a	Altimeter Test	<p>Perform the altimeter test per FAR 43, Appendix E. Refer to Table 7-10 Altimeter Test and Certification.</p>	<p>Test data for this test and other test shall be recorded and maintained in test facility files.</p>
11b	<p>Static Source Error Correction Test</p>	<p>Decrease altitude to zero.</p> <p>Select "Pressure" on <b>Vac.-Press. valve V1.</b></p>	

TABLE 7-12. Air Data Computer Test (cont'd)

STEP	DESCRIPTION	PROCEDURE	RESULT
11b	Static Source Error Correction Test (cont'd)	<p>Close pitot and <b>static control valves V2 &amp; V3</b> fully clockwise.</p> <p>Open <b>cross feed valve V6</b> counterclockwise at least 3 turns.</p> <p>Close <b>pitot and static bleed valves V4 &amp; V5</b> fully clockwise.</p> <p>Set <b>pump switch S1</b> to "ON".</p> <p>Slowly open <b>static control valve V2</b> counterclockwise while observing <b>climb indicator M2</b>. Do not exceed its limits.</p> <p>Adjust <b>static control valve V2</b> as necessary to stabilize altitude on zero.</p> <p>Close <b>cross feed valve V6</b> fully clockwise.</p> <p>Slowly open <b>pitot control valve V3</b> and set airspeed test points specified for the air data computer.</p> <p>Press disable button on the front of the air data computer and read altitude on the pilot's altimeter with button depressed.</p> <p>Reduce airspeed to zero by slowly opening <b>cross feed valve V6</b>. When airspeed is zero continue to open valve at least 3 turns.</p> <p>Select "Vacuum" on <b>Vac.-Press, valve V1</b>.</p>	<p>Altitude change shall be within the value specified in the manufacturer's specifications.</p>

TABLE 7-12. Air Data Computer Test

STEP	DESCRIPTION	PROCEDURE	RESULT
11b	Static Source Error Correction Test (cont'd)	<p>Increase altitude to that specified by manufacturer.</p> <p>Slowly open <b>static control valve V2</b> and adjust as necessary to set test altitude.</p> <p>Close <b>cross feed valve V6</b> fully clockwise.</p> <p>Slowly open and adjust as necessary the <b>pitot control valve V4</b> counterclockwise to the airspeed test points specified.</p> <p>Press the disable button on the front of the air data computer and read altitude on the pilot's altimeter with button depressed.</p> <p>Slowly open <b>cross feed valve V6</b> counterclockwise. After airspeed has returned to zero continue to open 3 turns.</p> <p>Return static pressure to field elevation by slowly opening <b>static bleed valve V5</b> counterclockwise while observing <b>climb indicator M2</b>. Do not exceed its limits.</p> <p>Adjust <b>static bleed valve V5</b> as necessary to maintain descent rate.</p> <p>Set <b>pump switch S1</b> to "OFF".</p> <p>Disconnect test set lines.</p> <p>Reconnect the aircraft's pitot and static lines.</p>	<p>Record altitude change and ensure that the valve is within that specified by the manufacturer.</p>



TABLE 7-12. Air Data Computer Tests (cont'd)

STEP	DESCRIPTION	PROCEDURE	RESULT
11b	Static Source Error Correction Test (cont'd)	Perform a static system leak check per the procedures in Table 7-9.	
		Turn off power to air data computer.	
11c	Paper Work	Record on the air data computer case that the tests required by FAR 91.170 have been performed, date of the test and the maximum altitude tested.	

**§ 91.170 Altimeter system tests and inspections.**

(a) No person may operate an airplane in controlled airspace under IFR unless, within the preceding 24 calendar months, each static pressure system and each altimeter instrument has been tested and inspected and found to comply with Appendix E of Part 43. The static pressure system and altimeter instrument tests and inspections may be conducted by—

(1) The manufacturer of the airplane on which the tests and inspections are to be performed;

(2) A certificated repair station properly equipped to perform these functions and holding—

(i) An instrument rating, Class I;

(ii) A limited instrument rating appropriate to the make and model altimeter to be tested;

(iii) A limited rating appropriate to the test to be performed;

(iv) An airframe rating appropriate to the airplane to be tested; or

(v) A limited rating for a manufacturer issued for the altimeter in accordance with § 145.101(b)(4) of this chapter; or

(3) A certificated mechanic with an airframe rating (static pressure system tests and inspections only).

(b) [Revoked.]

(c) No person may operate an airplane in controlled airspace under IFR at an altitude above the maximum altitude to which an altimeter of that airplane has been tested.

**Appendix E**

**Altimeter System Test and Inspection**

Each person performing the altimeter system tests and inspections required by § 91.170 shall comply with the following:

(a) Static pressure system:

(1) Ensure freedom from entrapped moisture and restrictions.

(2) Determine that leakage is within the tolerances established in § 23.1325 or § 25.1325, whichever is applicable.

(3) Determine that the static port heater, if installed, is operative.

(4) Ensure that no alterations or deformations of the airframe surface have been made that would affect the relationship between air pressure in the static pressure system and true ambient static air pressure for any flight condition.

(b) Altimeter:

(1) Test by an appropriately rated repair facility in accordance with the following subparagraphs. Unless otherwise specified, each test for performance may be conducted with the instrument subjected to vibration. When tests are conducted with the temperature substantially different from ambient temperature of approximately 25 degrees C., allowance shall be made for the variation from the specified condition.

(i) *Scale error*—With the barometric pressure scale at 29.92 inches of mercury, the altimeter shall be subjected successively to pressures corresponding to the altitude specified in Table I up to the maximum normally expected operating altitude of the airplane in which the altimeter is to be installed. The reduction in pressure shall be made at a rate not in excess of 20,000 feet per minute to within approximately 2,000 feet of the test point. The test point shall be approached at a rate compatible

with the test equipment. The altimeter shall be kept at the pressure corresponding to each test point for at least one minute, but not more than ten minutes, before a reading is taken. The error at all test points must not exceed the tolerances specified in Table I.

(ii) *Hysteresis* — The hysteresis test shall begin not more than 15 minutes after the altimeter's initial exposure to the pressure corresponding to the upper limit of the scale error test prescribed in subparagraph (i); and while the altimeter is at this pressure, the hysteresis test shall commence. Pressure shall be increased at a rate simulating a descent in altitude at the rate of 5,000 to 20,000 feet per minute until within 3,000 feet of the first test point (50 percent of maximum altitude). The test point shall then be approached at a rate of approximately 3,000 feet per minute. The altimeter shall be kept at this pressure for at least 5 minutes, but not more than 15 minutes, before the test reading is taken. After the reading has been taken, the pressure shall be increased further, in the same manner as before, until the pressure corresponding to the second test point (40 percent of maximum altitude) is reached. The altimeter shall be kept at this pressure for at least one minute, but not more than 10 minutes, before the test reading is taken. After the reading has been taken, the pressure shall be increased further, in the same manner as before, until atmospheric pressure is reached. The reading of the altimeter at either of the two test points shall not differ by more than the tolerance specified in Table II from the reading of

the altimeter for the corresponding altitude recorded during the scale error test prescribed in subparagraph (i).

(iii) *After effect*—Not more than 5 minutes after the completion of the hysteresis test prescribed in subparagraph (ii), the reading of the altimeter (corrected for any change in atmospheric pressure) shall not differ from the original atmospheric pressure reading by more than the tolerance specified in Table II.

(iv) *Friction*—The altimeter shall be subjected to a steady rate of decrease of pressure approximating 750 feet per minute. At each altitude listed in Table III, the change in reading of the pointers after vibration shall not exceed the corresponding tolerance listed in Table III.

(v) *Case leak*—The leakage of the altimeter case, when the pressure within it corresponds to an altitude of 18,000 feet, shall not change the altimeter reading by more than the tolerance shown in Table II during an interval of one minute.

(vi) *Barometric scale error*—At constant atmospheric pressure, the barometric pressure scale shall be set at each of the pressures (falling within its range of adjustment) that are listed in Table IV, and shall cause the pointer to indicate the equivalent altitude difference shown in Table IV with a tolerance of 25 feet.

[(2) Altimeters which are the air data computer type with associated computing systems, or which incorporate air data correction internally, may be tested in a manner and to specifications developed by the manufacturer which are acceptable to the Administrator.]

(c) Records. Comply with the provisions of §43.9 of this chapter as to content, form and disposition of the records. The person performing the altimeter tests shall record on the altimeter the date and maximum altitude to which the altimeter has been tested and the persons approving the airplane for return to service shall enter that data in the airplane log or other permanent record.

TABLE I

Altitude (feet)	Equivalent pressure (inches of mercury)	Tolerance ± (feet)
-1,000	31.018	20
0	29.921	20
500	29.385	20
1,000	28.856	20
1,500	28.335	25
2,000	27.821	30
3,000	26.817	30
4,000	25.842	35
6,000	23.078	40
8,000	22.225	60
10,000	20.577	80
12,000	19.029	90
14,000	17.577	100
16,000	16.216	110
18,000	14.942	120
20,000	13.750	130
22,000	12.636	140
25,000	11.104	155
30,000	8.885	180
35,000	7.041	205
40,000	5.538	230
45,000	4.355	255
50,000	3.425	280

TABLE II—TEST TOLERANCES

Test	Tolerance (Feet)
Case Leak Test	± 100
Hysteresis Test:	
First Test Point (50 percent of maximum altitude)	75
Second Test Point (40 percent of maximum altitude)	75
After Effect Test	30

TABLE III—FRICTION

Altitude (Feet)	Tolerance (Feet)
1,000	± 70
2,000	70
3,000	70
5,000	70
10,000	80
15,000	90
20,000	100
25,000	120
30,000	140
35,000	160
40,000	180
50,000	250

APPENDIX E

TABLE IV—PRESSURE-ALTITUDE DIFFERENCE

Pressure (Inches of Hg)	Altitude Difference (Feet)
28.10	-1727
28.50	-1340
29.00	-863
29.50	-392
29.92	0
30.50	+531
30.90	+893
30.99	+974

## Appendix F

### ATC Transponder Tests and Inspections

【The ATC transponder tests required by § 91.177 of this chapter may be conducted using a bench check or portable test equipment and must meet the requirements prescribed in paragraphs (a) through (d) of this Appendix. If portable test equipment with appropriate coupling to the aircraft antenna system is used, operate the test equipment at a nominal rate of 235 interrogations per second to avoid possible ATCRBS interference. An additional 3db loss is allowed to compensate for antenna coupling errors during receiver sensitivity measurements conducted in accordance with paragraph (c) (1) when using portable test equipment.

【(a) For reply radio frequency, interrogate the transponder and verify that the reply frequency of the system is  $1090 \pm 3$  MHz.

【(b) Suppression: When the transponder is interrogated on Mode 3/A at an interrogation rate between 230 and 1000 interrogations per second for Class 1B and 2B transponders or between 230 and 1200 interrogations per second for Class 1A and 2A transponders:

【(1) Verify that the transponder does not respond to more than 1 percent of the interrogations when the amplitude of  $P_2$  pulse is equal to the  $P_1$  pulse.

【(2) Verify that the transponder replies to at least 90 percent of the interrogations when the amplitude of the  $P_2$  pulse is 9db less than  $P_1$  pulse.

【If the test is conducted with a radiated test signal, the interrogation rate shall be  $235 \pm 5$  interrogations per second unless a higher rate has been approved for the test equipment used at that location.】

(c) Receiver sensitivity:

(1) Verify that receiver sensitivity of the system is  $-73 \pm 4$ dbm by use of a test set—

(i) Connected to the antenna end of the transmission line;

(ii) Connected to the antenna terminal of the transponder with a correction for transmission line loss; or

(iii) Utilizing a radiated signal.

(2) Verify that the difference in mode 3/A and mode C receiver sensitivity does not exceed 1db.

(d) Records:

Comply with the provisions of § 43.9 of this chapter as to content, form, and disposition of the records.



# CASTLEBERRY INSTRUMENTS & AVIONICS, INC.

817 DESSAU ROAD AUSTIN, TEXAS 78753  
PHONE (512) 251-3441 - REPAIR STATION NO.3812

## ALTIMETER & AIRSPEED CORRECTION SHEET

CUSTOMER NAME	DATE	CHECKED BY
ALTIMETER PART NO.	SERIAL NO.	

### TEST NO. 1 ALTITUDE PRESSURE

ALTITUDE FEET	ALTIMETER READS		ALTITUDE FEET	ALTIMETER READS	
	UP	DOWN		UP	DOWN
-1000			12,000		
0			14,000		
500			16,000		
1000			18,000		
1500			20,000		
2000			22,000		
3000			25,000		
4000			30,000		
6000			35,000		
8000			40,000		
10000			45,000		
			50,000		

### TEST NO. 2 FRICTION

ALTITUDE FEET	ALTIMETER READS	ALTITUDE FEET	ALTIMETER READS
1000		10,000	
2000		16,000	
3000		20,000	
6000		25,000	

### TEST NO. 3 TOLERANCES

CASE LEAK TEST	PRESSURE (IN. OF HG)	ALTITUDE DIFFERENCE (FEET)	ALTIMETER READS
AFTER EFFECT TEST	28.10	-1727	
POSITION ERROR	28.50	-1340	
HYSTERSIS TEST NO.1 (50%)	29.00	- 863	
HYSTERSIS TEST NO.2 (40%)	29.50	- 392	
	29.92	0	
	30.50	+ 531	
	30.90	+ 893	
	30.99	+ 974	

REMARKS:

THIS ALTIMETER WAS CALIBRATED AGAINST A MERCURY BAROMETER TYPE A-1, MANUFACTURE BY HASS INSTRUMENT CORP. AND CERTIFIED TRACEABLE TO THE NATIONAL BUREAU OF STANDARDS.

THIS ALTIMETER, AS INSTALLED IN PITOT & STATIC SYSTEM TEST BOX, MODEL NUMBER \_\_\_\_\_, SERIAL NUMBER \_\_\_\_\_, GIVES AN OVERALL SYSTEM MAXIMUM LEAK OF \_\_\_\_\_ FEET PER MINUTE AT 20,000 FEET INDICATED ALTITUDE.

AIRSPEED	P/N	S/N	CALIBRATION	
10	100	220	450	750
20	120	250	500	800
30	140	260	550	CASE LEAK
40	160	300	600	DAMPING
60	180	350	650	POS ERROR
80	200	400	700	

Maximum Cabin Differential Test Pressure vs. Test Altitude

<u>Maximum Cabin Differential Pressure</u> (lbs./sq. in.)	<u>Test Altitude</u> (feet)
1.5	3,000
2.5	5,100
4.2	9,000
5.5	12,400
8.5	22,000

Note: Unpressurized airplanes are tested at 1000 feet above field elevation for static leaks. (Max leak permitted 100 feet per minute)



# section 8

## appendix 8-5

### § 43.9 Content, form, and disposition of maintenance, rebuilding, and alteration records (except 100-hour, annual, and progressive inspections).

(a) *Maintenance record entries.* Except as provided in paragraphs (b) and (c) of this section, each person who maintains, rebuilds, or alters an aircraft, airframe, aircraft engine, propeller, or appliance shall make an entry in the maintenance record of that equipment containing the following information:

(1) A description (or reference to data acceptable to the Administrator) of the work performed.

(2) The date of completion of the work performed.

(3) The name of the person performing the work.

(4) If the aircraft, airframe, aircraft engine, propeller, or appliance is approved for return to service, the signature (and if a certificated mechanic, the certificate number) of the person who approved it.

(5) If the work performed is an inspection required under § 91.217 of this chapter for a large airplane, or a turbojet or turbo-propeller powered multiengine airplane, the entry must name the kind of inspection conducted (continuous airworthiness inspection

program, approved inspection program, etc.) and include a statement that—

(i) The inspection was performed in accordance with the instructions and procedures for the kind of inspection program selected by the owner or operator of the airplane; and

(ii) A signed and dated list of the defects, if any, found during the inspection was given to the owner or operator of the airplane.

In addition to the entry required by this paragraph, major repairs and major alterations shall be entered on a form, and the form disposed of, in the manner prescribed in Appendix B, by the person performing the work.

(b) Each holder of an air carrier or commercial operator certificate that is required by its operating certificate or by approved operations specifications to provide for a continuous airworthiness maintenance program, shall make a record of the maintenance, rebuilding, and alteration, on aircraft, airframes, aircraft engines, propellers, appliances, or parts thereof, which it operates, in accordance with the provisions of Part 121 or Part 127, of this chapter as appropriate.

(c) This section does not apply to persons performing the annual, 100-hour, and progressive inspections required by Part 91.

**§ 91.177 ATC transponder tests and inspections.**

(a) After January 1, 1976, no person may use an ATC transponder that is specified in §§ 91.24(a), 121.345(c), 127.123(b), or 135.143(c) of this chapter, unless, within the preceding 24 calendar months, that ATC transponder has been tested and inspected and found to comply with Appendix F of Part 43 of this chapter.

(b) The tests and inspections specified in paragraph (a) of this section may be conducted by—

(1) A certificated repair station properly equipped to perform those functions and holding—

(i) A radio rating, Class III;

(ii) A limited radio rating appropriate to the make and model transponder to be tested;

(iii) A limited rating appropriate to the test to be performed; or

(iv) A limited rating for a manufacturer issued for the transponder in accordance with § 145.101(b)(4) of this chapter; or

(2) A certificate holder authorized to perform maintenance in accordance with § 121.379 or § 127.140 of this chapter; or

(3) The manufacturer of the aircraft on which the transponder to be tested is installed, if the transponder was installed by that manufacturer.

**section 8**  
**appendix 8-7**

**§ 91.36 Data correspondence between automatically reported pressure altitude data and the pilot's altitude reference.**

No person may operate any automatic pressure altitude reporting equipment associated with a radar beacon transponder—

【(a) When deactivation of that equipment is directed by ATC;

【(b) Unless, as installed, that equipment was tested and calibrated to transmit altitude data corresponding within 125 feet (on a 95 percent probability basis) of the indicated or calibrated datum of the altimeter normally used to maintain flight altitude, with that altimeter referenced to 29.92 inches of mercury; or

【(c) After September 1, 1979, unless the altimeters and digitizers in that equipment meet the standards in TSO-C10b and TSO-C88, respectively.】

**§ 23.1325 Static pressure system.**

(a) Each instrument provided with static pressure case connections must be so vented that the influence of airplane speed, the opening and closing of windows, airflow variations, moisture, or other foreign matter will least affect the accuracy of the instruments except as noted in paragraph (b) (3) of this section.

(b) If a static pressure system is necessary for the functioning of instruments, systems, or devices, it must comply with the provisions of subparagraphs (1) through (3) of this paragraph.

(1) The design and installation of a static pressure system must be such that—

(i) Positive drainage of moisture is provided;

(ii) Chafing of the tubing, and excessive distortion or restriction at bends in the tubing, is avoided; and

(iii) The materials used are durable, suitable for the purpose intended, and protected against corrosion.

(2) A proof test must be conducted to demonstrate the integrity of the static pressure system in the following manner:

(i) *Unpressurized airplanes.* Evacuate the static pressure system to a pressure differential of approximately 1 inch of mercury or to a reading on the altimeter,

1,000 feet above the aircraft elevation at the time of the test. Without additional pumping for a period of 1 minute, the loss of indicated altitude must not exceed 100 feet on the altimeter.

(ii) *Pressurized airplanes.* Evacuate the static pressure system until a pressure differential equivalent to the maximum cabin pressure differential for which the airplane is type certificated is achieved. Without additional pumping for a period of 1 minute, the loss of indicated altitude must not exceed 2 percent of the equivalent altitude of the maximum cabin differential pressure or 100 feet, whichever is greater.

(3) If a static pressure system is provided for any instrument, device, or system required by the operating rules of this chapter, each static pressure port must be designed or located in such a manner that the correlation between air pressure in the static pressure system and true ambient atmospheric static pressure is not altered when the airplane encounters icing conditions. An anti-icing means or an alternate source of static pressure may be used in showing compliance with this requirement. If the reading of the altimeter, when on the alternate static pressure system differs from the reading of the altimeter when on the primary static system by more than 50 feet, a correction card must be provided for the alternate static system.

# section 8

## appendix 8-9

### § 25.1325 Static pressure systems.

(a) Each instrument with static air case connections must be vented to the outside atmosphere through an appropriate piping system.

(b) Each static port must be designed and located in such manner that the static pressure system performance is least affected by airflow variation, or by moisture or other foreign matter, and that the correlation between air pressure in the static pressure system and true ambient atmospheric static pressure is not changed when the airplane is exposed to the continuous and intermittent maximum icing conditions defined in Appendix C of this Part.

(c) The design and installation of the static pressure system must be such that—

(1) Positive drainage of moisture is provided; chafing of the tubing and excessive distortion or restriction at bends in the tubing is avoided; and the materials used are durable, suitable for the purpose intended, and protected against corrosion; and

(2) It is airtight except for the port into the atmosphere. A proof test must be conducted to demonstrate the integrity of the static pressure system in the following manner:

(i) *Unpressurized airplanes.* Evacuate the static pressure system to a pressure differential of approximately 1 inch of mercury or to a reading on the altimeter, 1,000 feet above the airplane elevation at the time of the test. Without additional pumping for a period of 1 minute, the loss of indicated altitude must not exceed 100 feet on the altimeter.

(ii) *Pressurized airplanes.* Evacuate the static pressure system until a pressure differential equivalent to the maximum cabin pressure differential for which the airplane is type certificated is achieved. Without additional pumping for a period of 1 minute, the loss of indicated altitude must not exceed 2 percent of the equivalent altitude of the maximum cabin differential pressure or 100 feet, whichever is greater.

(d) Each pressure altimeter must be approved and must be calibrated to indicate pressure altitude in a standard atmosphere, with a minimum practicable calibration error when the corresponding static pressures are applied.

(e) Each system must be designed and installed so that the error in indicated pressure altitude, at sea level, with a standard atmosphere, excluding instrument calibration error, does not result in an error of more than  $\pm 30$  feet per 100 knots speed for the appropriate configuration in the speed range between  $1.3 V_{S_0}$  with flaps extended and  $1.8 V_{S_1}$  with flaps retracted. However, the error need not be less than  $\pm 30$  feet.

(f) If an altimeter system is fitted with a device that provides corrections to the altimeter indication, the device must be designed and installed in such manner that it can be bypassed when it malfunctions, unless an alternate altimeter system is provided. Each correction device must be fitted with a means for indicating the occurrence of reasonably probable malfunctions, including power failure, to the flight crew. The indicating means must be effective for any cockpit lighting condition likely to occur.

[(g) Except as provided in paragraph (h) of this section, if the static pressure system incorporates both a primary and an alternate static pressure source, the means for selecting one or the other source must be designed so that—

[(1) When either source is selected, the other is blocked off; and

[(2) Both sources cannot be blocked off simultaneously.

[(h) For unpressurized airplanes, paragraph (g)(1) of this section does not apply if it can be demonstrated that the static pressure system calibration, when either static pressure source is selected, is not changed by the other static pressure source being open or blocked.]

#### Section 4. PITOT-STATIC SYSTEMS

**907. SYSTEM COMPONENTS.** Conventional design of the pitot-static system consists of pitot-static tubes or pitot tubes with static pressure ports or vents and their related heaters, if any, and includes lines, tubing, water drains and traps, and selector valves. Pressure actuated indicators such as the altimeter, air-speed, and rate-of-climb indicators, and control units such as air data transducers, and automatic pilots may be connected to the system.

**908. PITOT-STATIC TUBES AND LINES.** The pitot tube is installed with the axis parallel to the longitudinal axis of the aircraft unless otherwise specified by the manufacturer. When lines are attached or removed from a bulkhead feed-through fitting or at a union, precautions must be taken to assure that the line attached to the opposite end is not loosened, twisted, or damaged by rotation of the fitting. Such fittings normally are provided with a hex flange for holding.

**909. PRESSURE PORTS OR VENTS.** Static pressure ports or vents should be mounted flush with the fuselage skin. Inspect for elevation or depression of the port or vent fitting. Such elevation or depression may cause airflow disturbances at high speeds and result in erroneous airspeed indications.

**910. CLEANING OF SYSTEM.** Inspect air passages in the systems for water, paint, dirt, or other foreign matter. Probe the drains in the pitot tube to remove dirt or other obstructions. Tubing diameter should be checked when a problem is experienced with drainage of the pitot-static system or freezing at altitude. If this diameter is less than 3/8 inch, it should be replaced with larger tubing. Water may not drain freely from smaller diameter lines. Water or obstructions may be removed from the lines by disconnect-

ing them near the instrument and blowing clean, dry air through them. No instruments should be connected to the system during this process.

**911. HEATER ELEMENTS.** Some pitot-static tubes have replaceable heater elements, while others do not have replaceable elements. Check replacement of the heater element or the entire tube for proper operation by noting either ammeter current or that the tube or port gets hot to the touch.

**912. SYSTEM LEAK TESTING.** Pitot-static leak tests should be made with all instruments connected to assure that no leaks occur at instrument connections. Such tests should be made whenever a connection has been loosened or an instrument replaced.

**913. STATIC SYSTEM TEST.** Advisory Circular AC 43-203A describes an acceptable means of complying with static system tests required by FAR Part 91, section 91.170, for airplanes operated in controlled airspace under IFR. (This circular also provides information concerning the test equipment used, and precautions to be taken when performing such tests.) Aircraft not operated in controlled airspace under IFR should be tested in accordance with the aircraft manufacturer's instructions.

If the manufacturer has not issued instructions for testing static systems, the following may be used:

a. *Connect the test equipment* directly to the static ports, if practicable. Otherwise, connect to a static system drain or tee connection and seal off the static ports. If the test equipment is connected to the static system at any point other than the static port, it should be made at a point where the connection may be readily inspected for system integrity. Observe testing precautions given in paragraph 915.

b. **Apply a vacuum** equivalent to 1,000 feet altitude, (differential pressure of approximately 1.07 inches of mercury or 14.5 inches of water) and hold.

c. **After one minute, check** to see that the leakage has not exceeded the equivalent of 100 feet of altitude (decrease in differential pressure of approximately 0.105 inches of mercury or 1.43 inches of water).

**914. PITOT SYSTEM TEST.** Pitot systems should be tested in accordance with the aircraft manufacturer's instructions. If the manufacturer has not issued instructions for testing pitot systems, the following may be used:

a. **Test the pitot system** by sealing the drain holes and connecting the pitot pressure openings to a tee to which a source of pressure and a manometer or reliable airspeed indicator is connected.

b. **Apply pressure** to cause the airspeed indicator to indicate 150 knots (differential pressure 1.1 inches of mercury or 14.9 inches of water), hold at this point and clamp off source of pressure. After 1 minute, the leakage should not exceed 10 knots (decrease in differential pressure of approximately 0.15 inches of mercury or 2.04 inches of water). **Warning: Do not apply suction to pitot lines.**

**915. PRECAUTIONS IN TESTING.** Observe the following precautions in all pitot-static system leak testing:

a. **Perform all other work and inspections** before leak testing.

b. **Use a system diagram.** It will prevent applying reverse pressure to any instrument, and help determine the location of a leak while observing instrument indications.

c. **Be certain that no leaks exist in the test equipment.**

d. **Run full range tests only if you are thoroughly familiar** with the aircraft instrument system and the test equipment.

e. **Pressure in the pitot system** must always be equal to or greater than that in the static system. A negative differential pressure across an airspeed indicator can damage it.

f. **The rate of change or the pressure applied** should not exceed the design limits of any pitot or static instruments connected to the systems.

g. **After the conclusion of the leak test,** be certain that the system is returned to its normal flying configuration, such as removing tape from static ports and pitot tube drain holes and replacing the drain plugs, etc.

**916.-926. RESERVED.**

# ADVISORY CIRCULAR



DEPARTMENT OF TRANSPORTATION  
Federal Aviation Administration  
Washington, D.C.

---

## FAR GUIDANCE MATERIAL

---

**Subject:** ALTIMETER AND STATIC SYSTEM TESTS AND INSPECTIONS

1. PURPOSE. This advisory circular contains acceptable methods for testing altimeters and static systems. It also provides general information concerning the test equipment used and precautions to be taken when performing such tests.
2. CANCELLATION. Advisory Circular No. AC 43-203A dated 6/6/67 is canceled.
3. RELATED PUBLICATIONS.
  - a. Federal Aviation Regulations (FAR) Part 43, Appendix E, Sections 43.3 and 43.5; FAR Part 91, Section 91.170; FAR Part 145, Section 145.47.
  - b. Advisory Circular 43-2A, Minimum Barometry for Calibration and Test of Atmospheric Pressure Instruments.
  - c. U.S. Standard Atmosphere, 1976.
4. GENERAL. Certain aircraft are required by Section 91.170 of the FAR to have altimeter and static system tests. These tests are described in Appendix E of Part 43 of the FAR. Equipment, materials, and required tests for test equipment are specified in Section 145.47 of the FAR. Persons authorized to perform altimeter and static systems tests are identified in Section 91.170 of the FAR.
5. STATIC PRESSURE SYSTEM TEST. Performance of this test with all static instruments connected will assure that leaks have not been introduced at instrument connections. Use of the following procedures is satisfactory as a means for compliance with the static pressure system proof test and inspection:
  - a. Visually inspect the ports, plumbing, accessories, and instruments connected to the static system and repair or replace those parts which are defective; e.g., broken "B" nuts, cracked flare sleeves, deteriorated

---

Initiated by: AFS-830



flexible tubing, bad valves, etc. Purge the system, if necessary, to remove foreign matter which may have accumulated in the tubing.

b. Check the static port heater to assure proper operation by noting either ammeter current or that the pitot tube or static port gets hot to the touch.

c. When an aircraft has more than one static system, test each system separately to assure their independence and to assure that the leak rate for each system is within tolerance.

d. Connect the test equipment directly to the static ports, if practicable. Otherwise, connect to a static system drain or tee connection and seal off the static ports. If the test equipment is connected to the static system at any point other than the static port, it should be made at a point where the connection may be readily inspected for system integrity after the system is returned to its normal configuration. Remove all static port seals after completion of the static system test.

e. For unpressurized airplanes, conduct the static pressure system proof test to the standards prescribed in FAR Part 23.1325(b)(2)(i) or Part 25.1325(c)(2)(i), as applicable (see paragraph 9 for precautions).

f. For pressurized airplanes, conduct the static pressure system proof test to the standards prescribed in FAR Part 23.1325(b)(2)(ii) or Part 25.1325(c)(2)(ii), as applicable (see paragraph 9 for precautions).

(1) An accurate vacuum gauge referenced to atmospheric pressure and connected to the static pressure system may be used to measure the equivalent cabin differential pressure.

(2) Either the altimeter in the airplane under test or that in the test equipment may be used as a vacuum gauge, provided that barometric pressure is converted to pressure in pounds per square inch (PSI). A convenient formula for this conversion is:

$$\text{PSI} = \frac{\text{inches of mercury}}{2.036}$$

(3) The following steps are suggested to use the altimeter as a vacuum gauge:

Step 1. Convert the actual local barometric pressure (NOT reduced to sea level) to PSI;

Step 2. Subtract the approved maximum cabin differential pressure in PSI from the PSI value obtained in Step 1;

Step 3. Convert the PSI value obtained in Step 2 to inches of mercury, using the formula: Inches of mercury = PSI x 2.036;

Step 4. The test pressure expressed in inches of mercury can be converted to test altitude using Table IV GEOPOTENTIAL ALTITUDE, ENGLISH UNITS, contained in the document titled "U.S. Standard Atmosphere, 1976 (Stock No. 003-017-00323-0)," which is available from Superintendent of Documents, U.S. Government Printing Office, Washington, D.C. 20402 at a cost of \$6.20.

EXAMPLES:

$$\text{Step 1. PSI} = \frac{25.39}{2.036} = 12.47 \text{ PSI}$$

$$\text{Step 2. } 12.47 - 5.3 = 7.17 \text{ PSI}$$

$$\text{Step 3. Inches Hg} = 7.17 \times 2.036 = 14.60 \text{ inches Hg}$$

$$\text{Step 4. } 14.60 \text{ inches Hg} = 18,600 \text{ feet altitude}$$

6. ALTIMETER TEST. Altimeter tests are performed in accordance with FAR Part 43, Appendix E. If the altimeter test is to be performed with the instrument installed in the airplane, the following guidelines should be observed:

a. The static leak test should be conducted first to assure that there are no static system leaks to influence altimeter indications.

b. Permit the altimeter to stabilize after a flight before performing the test.

c. Use portable test equipment or barometric test equipment as described in paragraph 7, Altimeter Test Equipment.

d. When vibration is applied to the instrument, assure that it is not of a magnitude which will mask a sticky altimeter.

7. ALTIMETER TEST EQUIPMENT. The following test equipment is acceptable for testing altimeters:

a. Mercurial barometers with accuracies specified in and maintained in accordance with Advisory Circular 43-2A.

b. High accuracy portable test equipment (with appropriate correction card) maintained in accordance with FAR 145.47(b). It has been found that calibration checks of the test equipment in accordance with the following schedule provides a satisfactory level of performance:

(1) Each thirty days, after initial calibration, the equipment should be checked for accuracy against:

(i) A barometer described in a. above, or,

(ii) An altimeter (with appropriate correction card) which has been calibrated, within the past thirty days, against a barometer described in 7a.

(2) Each day the equipment should be checked for accuracy at station pressure using an aneroid or mercurial barometer. If the equipment is not used daily, a "before use" test may be substituted for the daily test.

(3) The thirty-day calibration period in (1) may be extended provided the calibration records of the individual test equipment reflect continued accuracy.

8. MAINTENANCE RECORD ENTRY. The following example of a permanent maintenance record entry will be satisfactory for compliance with FAR Part 43.9:

(1) Example: I certify that the altimeter and static system tests required by FAR Part 91.170 have been performed. The altimeter was tested to \_\_\_\_\_ feet on (date if altimeter test)

Signature \_\_\_\_\_  
Date (of static system test) \_\_\_\_\_  
Certificate Number \_\_\_\_\_

(2) The date of the actual altimeter test and maximum altitude to which the altimeter was tested should be recorded on the altimeter by the person making the altimeter test.

9. PRECAUTIONS. This section contains information about precautions that can be taken to avoid damage to sensitive instruments that are connected to static systems during static system tests.

a. Before any static system is tested, it should be determined that the design limits of instruments attached to it will not be exceeded during test. To determine this, it is necessary to locate and identify all instruments attached to the system. In addition to the altimeter, airspeed, and rate of climb, many airplanes use static pressure for the operation of autopilots, flight recorders, air data computers, altitude reporting digitizers, etc. The use of a static system diagram of the airplane involved may be helpful in locating all of the instruments. If a diagram is not available, the instruments can be located by tracing the physical installation.

b. Damage can occur to instruments that are connected to both the static system and pitot system when only the static system is evacuated. The maximum design differential pressure of these instruments may be exceeded. One method to prevent this type of damage is to tie both the pitot and static systems together when conducting static system checks. This should result in zero differential pressure regardless of the degree of static system evacuation. It should be noted that a leak in either system will be indicated on the test set.

1

c. Safeguards should be taken to prevent accidental disconnection of the test equipment plumbing from the aircraft or the test equipment while the static system is evacuated. The resultant sudden pressure change may damage both the test instruments and the aircraft instruments.

d. Whenever blockage of the static lines is suspected, they should be purged before the static pressure system test is performed. Besides the obvious benefits of removing foreign objects from the lines, purging may keep such objects from entering the test equipment. Since purging applies positive pressure to lines, the following precautions should be taken:

- (1) Disconnect all instruments and air data sensors.
- (2) Cap off those lines not being purged.
- (3) Restrain hoses which can whip due to purge pressure.
- (4) Assure that lines are clear by feeling discharge pressure at ports.
- (5) Clean system drains and traps after purging since they can act as a sump for foreign material.

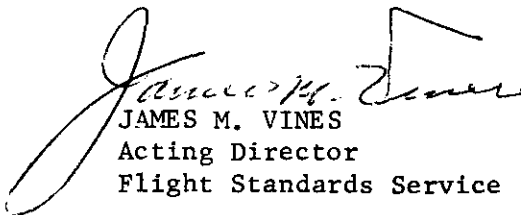
  
JAMES M. VINES  
Acting Director  
Flight Standards Service

AC NO: 43-6A

DATE: 11/11/77

section **8**  
appendix 8-12



# ADVISORY CIRCULAR

## DEPARTMENT OF TRANSPORTATION FEDERAL AVIATION ADMINISTRATION

**SUBJECT:** AUTOMATIC PRESSURE ALTITUDE ENCODING SYSTEMS AND TRANSPONDERS  
MAINTENANCE AND INSPECTION PRACTICES

---

1. PURPOSE. This circular provides information concerning the installation of encoding altimeters based upon recently acquired operating experience and on the maintenance of ATC transponders.
  2. CANCELLATION. AC 43-6 dated 9/19/74 is cancelled.
  3. REFERENCES. FAR 91.177(a), FAR 43 Appendix F, FAR 91.36(b), FAR 37.197 (TSO C-88), and FAR 37.180 (TSO C-74).
  4. BACKGROUND. Field experience has demonstrated the following problems have occurred following the installation of an encoding altimeter.
    - a. Failure to ensure that the transponder and/or encoding altimeter are compatible with the altitude operating envelope of the aircraft in which they are installed.
    - b. Installation not based upon approved data.
    - c. Installation of servo controlled (nonreverting) altimeters without an adequate backup provision in the event of total electrical failure.
    - d. Improper functional checkout after alteration (e.g., failure to perform a static system check or failure to correlate the altimeter indicated altitude to the altitude information being transmitted).
  5. INSTALLATION. Any appropriately rated person (as specified in FAR 43.3) may perform an aircraft alteration which consists of installing an encoding altimeter, blind encoder or transponder system. The approval of the aircraft for return to service, however, can only be given by those persons authorized in FAR 43.7 after a suitable functional check has been performed, where applicable, in order to determine that the altered system will perform its intended function(s).
- 

Initiated by: AFS-804

For those situations where the services of a certificated repair station are utilized for the installation of an automatic pressure altitude reporting system, or for any portion of such a system, we have listed several installation situations and the repair station ratings necessary to cover the particular situation. Any special or unusual situations, other than those listed, should be resolved with the local FAA district office.

<u>Types of Installation</u>	<u>Repair Station Ratings</u>
Encoding Altimeter	Airframe (A), Radio Class 3 (R-3), Instrument Class 1 (I-1), or Specialized Service (SS)
Digitizer (blind encoder)	A, R-3, I-1, or SS
Transponder and Encoding Altimeter	A, R-3, I-1, or SS

Any of the above listed repair station ratings could also be limited to specific make(s) and model(s) airframe, transponder, or encoding altimeter. Each installation should be made in accordance with approved data and the work performed or supervised by appropriately certificated personnel. Before attempting the installation of an aircraft altitude reporting system, the installing facility should assure the following:

- a. The required test equipment, technical data, and qualified personnel are available to perform or arrange to have performed a static system check, as required by FAR 91.170, to verify the integrity of the newly installed or altered system.
- b. The capability exists to determine the actual altitude information being transmitted by the transponder as referenced against the pilot's altimeter (altitude reference).
- c. Appropriately rated or qualified personnel are available to perform any necessary structural modifications.
- d. The facility is authorized to approve the aircraft for return to service after all alterations and testing are completed.
- e. The data approval necessary for the substitution of an encoding altimeter for the altimeter currently shown on the aircraft's "approved equipment listing," is available.

6. APPROVED DATA ALTERNATIVES.

- a. Manufacturer Drawings/Service Bulletins (FAA Approved) which list

approved replacement/substitution encoding altimeters or instructions for the installation of certain digitizers (blind encoders) may be used.

- b. Where no prior approval has been given, a supplemental type certificate (STC) or field approval should be requested. The person approving the aircraft for return to service should comply with all provisions of FAR 43.9.
  - c. Field Approvals. In some cases, the facility making the installation meets the qualifications in paragraphs 5. a. through 5. e. and has demonstrated to the Administrator its ability to install this equipment on a representative number of similar type installations through prior field approvals. References to these previous approvals on FAA Form 337 (Major Repair and Alteration, Airframe, Powerplant, Propeller, or Appliance) would constitute previously approved data and may not require a separate field approval.
  - d. Alterations using data which do not differ appreciably from a previously approved alteration may not require new or additional approval. When questions arise, contact your local FAA field office for guidance.
7. TESTS AND INSPECTIONS. The purpose of FAR 91.177, ATC Transponder Tests and Inspections, is to ensure the use of a properly operating transponder in the National Airspace System. The following information sets forth one means, but not the only means, of demonstrating compliance with the maintenance requirements contained in FAR 91.177 and prescribed in FAR 43, Appendix F, governing the testing of ATC transponders.
- a. Transponder tests and inspections FAR 91.177, FAR 43, Appendix F.
    - (1) Reply radio frequency. Interrogate the transponder and verify, by use of any frequency measuring technique, that the reply frequency is 1090+3 MHz. The accuracy of the measuring device should be at least  $\pm .5$  MHz. In the event the frequency measurement is not conducted by radiated method, necessary compensations should be made for any frequency deviation which may occur due to installation.
    - (2) Suppression. Interrogate the transponder with a Mode 3/A interrogation signal at a nominal repetition rate of 235 (nominal is considered to be 235+5 IPS) interrogations per second and at a signal level 3 db above receiver minimum trigger level. Adjust P2 pulse equal in amplitude to P1 pulse and verify that the reply rate is no greater than 3 replies per second. (Percentage of reply should not exceed 1.0 percent.) Adjust P2 pulse amplitude 9 db less than P1 pulse, and verify that the reply rate is at least 211 replies per second.

- (3) Receiver sensitivity. With the test set connected to the antenna end of the transmission line, or connected to the antenna terminal of the transponder with a correction for transmission line loss, interrogate the transponder with a Mode 3/A interrogation signal at any repetition rate recommended by the transponder manufacturer. When radiation techniques are used, the interrogation signal repetition rate should be a nominal 235 interrogations per second. This pulse repetition rate was selected to reduce interference to active aircraft in the air traffic control system. Adjust P1 and P3 equal in amplitude and apply a signal level known to be below receiver minimum trigger level (MTL). Increase the signal level until the transponder reply is 211 replies per second (90 percent reply rate). This is the receiver minimum trigger level (MTL). Verify the MTL is between 69 to 77 db below 1 milliwatt. Test equipment attenuator accuracy should be within  $\pm 3$  db. Repeat the test using a Mode C interrogation signal and verify the MTL is within 1 db of the reading obtained on Mode 3/A.
- b. Bench Tests. Transponders may be bench tested for compliance with FAR 43, Appendix F, and functionally checked after installation in the aircraft, provided that during the bench check the transponder operates into an antenna system presenting the same VSWR characteristics and cable attenuation as that in the airplane.
- c. Portable line test equipment. Portable line test equipment may be used for any of the tests specified in paragraph 7. a. provided it is maintained under a regular calibration program acceptable to the Administrator. If portable test equipment is used with appropriate coupling to the aircraft antenna system, an additional 3 db tolerance is permitted to compensate for antenna coupling errors during receiver sensitivity measurements.
- If the portable test equipment has a fixed R.F. output, it may be necessary to use a fixed precision attenuator in conjunction with a variable precision attenuator to determine the receiver minimum triggering level. Such attenuators should be maintained on a regular calibration schedule and have appropriate calibration charts. The repair facility is responsible for assuring the accuracy of the attenuators.
- d. Removal and Replacement. Removal and replacement of transponder units, during the two-year period subsequent to testing in accordance with FAR 91.177, will not invalidate the test results. A repaired or replacement transponder may be installed without repeating FAR 91.177, provided the unit being installed has been tested by the agency for reply radio frequency, suppression, and receiver sensitivity in accordance with the manufacturer's instructions.
- e. Maintenance Records. Maintenance record entries should be made in accordance with FAR 43.9.



8. AN ACCEPTABLE MEANS OF TESTING FOR COMPLIANCE WITH FAR 91.36(b).

- a. FAR 91.36, Data correspondence between automatically reported pressure altitude data and the pilot's altitude reference states, in part, that:

No person may operate any automatic pressure altitude reporting equipment associated with a radar beacon transponder --

(b) Unless, as installed, that equipment was tested and calibrated to transmit altitude data corresponding within 125 feet (on a 95 percent probability basis) of the indicated or calibrated datum of the altimeter normally used to maintain flight altitude, with that altimeter referenced to 29.92 inches of mercury.

- b. The following simplified test of the automatic pressure altitude transmission system data correspondence, as required by FAR 91.36(b), can be used to demonstrate compliance of a newly installed altitude reporting system. Connect the transponder test set directly to the antenna terminal of the transponder, or to the antenna end of the transmission line (so as not to radiate an interfering signal).
- (1) All aircraft which have altitude reporting transponders installed (Mode C capability) should be checked to assure that only the framing pulses (F1 and F2) are transmitted in response to Mode C interrogations, when the altitude reporting feature is turned off.
  - (2) All transponder-equipped aircraft which have altitude reporting equipment installed should be tested at the flight levels set forth in Appendix 1 (Table 1 for encoding altimeters or Table 2 for blind encoders), by alternately interrogating the transponder on Mode 3/A and Mode C and observing the pulse train output, or the decoded altitude display on those test sets capable of decoding the pulse train.
  - (3) Set the altimeter normally used to maintain flight altitude to 29.92 inches of mercury (1013.2 millibars).
  - (4) Select the test points called out in Tables 1 or 2 (sea level) and the maximum operating altitude of the aircraft. Test each of these test points for increasing altitude and for decreasing altitude.
  - (5) Apply pressure to the static system, or directly to altimeter.

If separate static systems serve altimeters and digitizers, simultaneously apply identical pressure to each. Approach each test point slowly, decreasing pressure for increasing altitude, and vice versa, until a transition to the test point value occurs in the digital output. Record the pilot's altimeter reading at the instant of transition.

(6) Encoding digitizers, which are separate units (blind encoders) having their own individual pressure sensor, should be checked against the pilot's altimeter upon installation to ensure that the overall system accuracy of FAR 91.36(b) is met. It will be necessary to perform a check of the system accuracy any time either the encoder or altimeter is replaced. Matched components should be identified and the calibration information recorded.

(a) The matched set (blind encoder and altimeter) should be shop tested and calibrated at ambient temperature.

(b) This abbreviated environmental temperature test is only valid when both units are installed in the same environmental location (i.e., both units mounted on instrument panel or in near vicinity of one another). Other installations require FAA Engineering approval.

(7) In addition, where an installation allows for the blind encoder to be connected to a static source other than the static source connected to the altimeter normally used to maintain flight altitude, the following corrections should be applied during certification of compliance to FAR 91.36(b):

(a) The difference between both static sources should be determined (in flight) and recorded. (This information may be available from the original aircraft certification data.)

(b) The differences determined in (a) above (static source errors) should be used as a correction factor when checking for compliance with FAR 91.36(b).

9. TESTING PRECAUTIONS AND INSTALLATION RECOMMENDATIONS.

a. Adequate precautions should be taken to avoid damage to any instruments connected to the aircraft pitot-static system, either by "TEE" connecting the pitot and static lines together, or by connecting the vacuum source directly to the altimeter and encoder when separate units are involved. The aircraft static system should be returned to ambient pressures prior to disconnecting pneumatic test equipment from aircraft/instruments. After completion of all testing, a leakage test of the static system should be performed if the static system has been opened.

- b. In aircraft equipped with plastic pitot or static lines, adequate precaution should be taken to avoid collapsing the plastic tubing at the higher differential pressures.
- c. The blind encoder or encoding altimeter should have an altitude encoding capability up to at least the service ceiling or maximum certificated altitude of the aircraft in which it is installed. If the altitude reporting system will not function throughout the aircraft operational envelope (up to the aircraft maximum operating altitude), a placard stating the aircraft altitude limitation should be installed.
- d. The barometric correlation adjustment should not be adjusted in the field; changing this adjustment will nullify the correspondence between altimeter and its encoding digitizer or the associated blind encoder.
- e. Some altimeters may exhibit a tendency toward jerkiness (when not under vibration). If the jerkiness appears excessive, then the friction test should be conducted as described in FAR 43, Appendix E(b)(iv).
- f. Automatic altitude reporting system installations (either blind encoder or encoding altimeter types) may be shop tested for correspondence (using the transponder decoded output) and then functionally checked after installation in the aircraft, provided the same transponder encoding digitizer, altimeter and wiring harness, and coaxial cable are either installed in the aircraft or accurately compensated for.

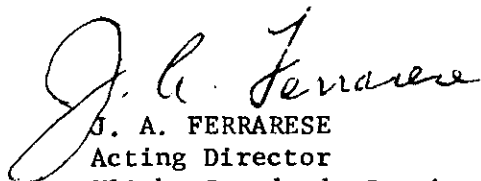
  
J. A. FERRARESE  
Acting Director  
Flight Standards Service

APPENDIX 1 - TABLES AND GLOSSARY

TABLE 1 ALTITUDE INFORMATION PULSE POSITIONS  
 (Encoding Altimeters)

RANGE (1)		PULSE POSITION (0 to 1 in a pulse position denotes absence or presence of a pulse, respectively)											Correspondence Tolerance
INCREMENTS (FEET)		D <sub>2</sub>	D <sub>4</sub>	A <sub>1</sub>	A <sub>2</sub>	A <sub>4</sub>	B <sub>1</sub>	B <sub>2</sub>	B <sub>4</sub>	C <sub>1</sub>	C <sub>2</sub>	C <sub>4</sub>	
-50 to	+50 (2)	0	0	0	0	0	0	1	1	0	1	0	(1) ↓
950 to	1050	0	0	0	0	0	1	1	0	0	1	0	
1050 to	1150	0	0	0	0	0	1	1	0	1	1	0	
1250 to	1350	0	0	0	0	0	1	1	1	1	0	0	
1750 to	1850	0	0	0	0	0	1	0	1	0	0	1	
2550 to	2650	0	0	0	0	0	1	0	0	0	1	1	
2750 to	2850	0	0	0	0	1	1	0	0	0	0	1	
6750 to	6850	0	0	0	1	1	0	0	0	0	0	1	
14750 to	14850 (2)	0	0	1	1	0	0	0	0	0	0	1	
30750 to	30850 (3)	0	1	1	0	0	0	0	0	0	0	1	
Max Oper Alt													

NOTES:

(1) Reference FAR 43, Appendix E.

(2) Identifies transponder pulse positions and altitude limits necessary to check Class 1B and 2B transponders (equipment designed to operate at 15,000 feet and below; reference FAR 37.180).

(3) Identifies transponder pulse positions and altitude limits necessary to check Class 1A and 2A transponders (that equipment designed to operate above 15,000 feet; reference FAR 37.180).

TABLE 2 ALTITUDE INFORMATION PULSE POSITION  
(Blind Encoders)

RANGE	PULSE POSITION (0 to 1 in a pulse position denotes absence or presence of a pulse, respectively)											(1) Altimeter Scale Error Tolerance	Correspondence Tolerance	
	INCREMENTS (FEET)	D <sub>2</sub>	D <sub>4</sub>	A <sub>1</sub>	A <sub>2</sub>	A <sub>4</sub>	B <sub>1</sub>	B <sub>2</sub>	B <sub>4</sub>	C <sub>1</sub>	C <sub>2</sub>			C <sub>4</sub>
-1050 to -950	0	0	0	0	0	0	0	0	0	0	1	0	±20	(1) ↓
-50 to +50	0	0	0	0	0	0	0	1	1	0	1	0	±20	
450 to 550	0	0	0	0	0	0	0	1	0	0	1	0	±20	
950 to 1050	0	0	0	0	0	0	1	1	0	0	1	0	±20	
1050 to 1150	0	0	0	0	0	0	1	1	0	1	1	0	±20	
1250 to 1350	0	0	0	0	0	0	1	1	1	1	0	0	±23	
1450 to 1550	0	0	0	0	0	0	1	1	1	0	1	0	±25	
1750 to 1850	0	0	0	0	0	0	1	0	1	0	0	1	±27	
1950 to 2050	0	0	0	0	0	0	1	0	1	0	1	0	±30	
2550 to 2650	0	0	0	0	0	0	1	0	0	0	1	1	±30	
2650 to 2750	0	0	0	0	0	0	1	0	0	0	0	1	±30	
2950 to 3050	0	0	0	0	0	1	1	0	0	0	1	0	±30	
3950 to 4050	0	0	0	0	0	1	1	1	1	0	1	0	±35	
5950 to 6050	0	0	0	0	0	1	0	0	1	0	1	0	±40	
6750 to 6850	0	0	0	0	1	1	0	0	0	0	0	1	±48	
7950 to 8050	0	0	0	0	1	1	0	1	1	0	1	0	±60	
9960 to 10050	0	0	0	0	1	1	1	0	1	0	1	0	±80	
11950 to 12050	0	0	0	0	1	0	1	1	1	0	1	0	±90	
13950 to 14050	0	0	0	0	1	0	0	0	1	0	1	0	±100	
14750 to 14850	0	0	0	1	1	0	0	0	0	0	0	1	±104	
15959 to 16050	0	0	0	1	1	0	0	1	1	0	1	0	±110	
17950 to 18050	0	0	0	1	1	0	1	0	1	0	1	0	±120	
19950 to 20050	0	0	0	1	1	1	1	1	1	0	1	0	±130	
21950 to 22050	0	0	0	1	1	1	0	0	1	0	1	0	±140	
24950 to 25050	0	0	0	1	0	1	1	1	0	0	1	0	±155	
29950 to 30050	0	0	0	1	0	0	0	0	1	0	1	0	±180	
30750 to 30850	0	0	1	1	0	0	0	0	0	0	0	1	±184	
34950 to 35050	0	0	1	1	0	1	1	0	0	0	1	0	±205	
39950 to 40050	0	0	1	1	1	1	0	1	1	0	1	0	±230	
44950 to 45050	0	0	1	1	1	0	0	1	0	0	1	0	±255	
49950 to 50050	0	0	1	0	1	0	1	0	1	0	1	0	±280	

Glossary of Terms:

1. **Approved:** Unless used with reference to another person, means approved by the Administrator.
2. **Blind Encoder (Digitizer):** An altitude reporting encoder which is pressure operated, having no altitude display; is not part of a pressure/altitude indicating device or system; does not contain an external means for barometric setting; supplies the altitude reporting information to the A.T.C. transponder.
3. **Data:** Means any drawings, sketches, stress analysis, reports, operating limitations, or photographs which support or describe an alteration.
4. **Encoding Altimeter (Pressure Altitude):** An altitude indicator which displays to the pilot the pressure/altitude sensed by the device and produces an altitude reporting digital code output.
5. **Indicated Datum of the Altimeter:** Is the altitude displayed by the altimeter when an ideal absolute pressure is applied to the sensing member of the altimeter, and not corrected for instrument error (scale error), nor corrected for static source error.
6. **Calibrated Datum of the Altimeter:** Is the correction applied via a specific calibration card applicable to a specific altimeter to correct for instrument error (scale error) only.
7. **Correspondence:** Is the altimeter's displayed pressure/altitude (indicated or calibrated datum) compared to encoded altitude output from the blind encoder or encoding altimeter; for the entire period (from the moment that the code output changes to a value to the moment the code output changes to the next value while the pressure/altitude is changing) that output code remains at the same digital information.
8. **Matched Components:** Consist of an altimeter and a blind encoder which have been tested and calibrated together and, as a combination, meet the requirements of FAR 91.36(b).

# ADVISORY CIRCULAR



DEPARTMENT OF TRANSPORTATION  
Federal Aviation Administration  
Washington, D.C.

---

**Subject:** ALTIMETER SETTING SOURCES

1. PURPOSE. This advisory circular provides the aviation public and industry with guidelines for setting up reliable altimeter setting sources.
2. CANCELLATION. Advisory Circular (AC) 91-14C, dated 6/14/78 is canceled.
3. GUIDELINES. An altimeter setting source should either:
  - a. Consist of the Standard Altimeter Setting Indicator (ASI); or
  - b. Meet the minimum technical requirements specified in paragraphs (1) and (2) below and be operated in accordance with paragraph (3).

(1) Instrumentation. Two aircraft-type sensitive altimeters should meet the specifications of Technical Standard Order C10b or meet the standards of Federal Aviation Regulation (FAR) Part 43, Appendix E. One aircraft-type sensitive altimeter meeting these specifications may be utilized at locations where a Part 121 or 135 operator has established a procedure for periodic cross-checking of the altimeter as specified in paragraph 3b(2)(iii). The height (of the instruments) above mean sea level, surveyed accurately within one foot, is marked on the instruments or posted immediately adjacent to them. Outside venting of the altimeter or altimeters is necessary only when the room in which the instruments are located is shown to be subject to a pressure differential compared to ambient atmospheric pressure.

(2) Calibration. The instruments should be calibrated and recertified to the specifications of Part 43, Appendix E, by an appropriately certificated, FAA-approved instrument repair station:

(i) Within 30 days prior to initial installation or retention as a spare, and every 24 months thereafter.

(ii) At stations utilizing two altimeters, anytime a difference of more than .05 of an inch of mercury exists between the two

---

Initiated by: AFS-830

Instruments with indicator hands set to the instrument elevation. Immediately after calibration, the difference between the two instruments should not exceed .02 of an inch of mercury.

(iii) At stations utilizing one altimeter, any time a difference of more than .04 of an inch of mercury exists on two successive cross-checks between the station reference altimeter and the mean of the readings obtained from the two altimeters installed in an aircraft maintained under the provisions of Part 121 or the continuous airworthiness maintenance provisions of FAR Part 135.

(iv) The instruments should be calibrated to achieve maximum accuracy in the altitude range at which they will be used. (Instruments so calibrated should be marked "not for use in aircraft.") All readings should be adjusted as required by the altimeter correction card furnished by the calibration station. The instrument should be kept in a temperature-controlled environment similar to the temperature at which the instrument was calibrated.

(3) Procedures. The operator should establish procedures to ensure that responsible persons are competent to obtain accurate altimeter settings.

(1) At stations employing two altimeters, a tested method is as follows:

(A) Set both instruments to the posted height, tap or vibrate each to remove friction effects, then reset if necessary.

(B) Adjust the readings as required by the altimeter correction card.

(C) The altimeter setting, in inches of mercury, appears in the small window. The difference between instrument readings may not exceed .05 of an inch. The lower of the two readings is the official altimeter setting.

(D) The difference between instrument readings should be logged in a permanent record at least once a day.

(ii) At stations using one altimeter, a tested method is as follows:

(A) Set the instrument to posted height, tap or vibrate to remove friction effects, then reset if necessary.

(B) Adjust the reading as required by the altimeter correction card, and record the reading.



(C) From a Part 121 or 135 aircraft parked on a designated ramp area of known elevation, secure altimeter readings from both captain's and first officer's altimeters which should be adjusted to indicate the actual elevation of the ramp plus the height of the instruments above the ramp before the altimeters are read.

(D) Determine the mean of the two aircraft altimeter readings and compare the mean with the reading from the station altimeter. If the difference between the mean and the station altimeter exceeds .04 of an inch, the altimeter setting should be reported as "missing," and if the difference exceeds .04 of an inch on two successive cross-checks, the altimeter should be recalibrated before further use.

(E) The cross-check should be done daily, if an aircraft is available, but not less than three times a week. The difference between the reference instrument and the mean of the aircraft altimeter readings should be logged in a permanent record.

(4) System Approvals. Altimeter setting sources installed in accordance with this AC and intended for use with approved instrument approach procedures will require initial approval and periodic inspection by the FAA. Initial approval and annual inspections should be accomplished by the appropriate FAA district office (General Aviation District Office, Air Carrier District Office or Flight Standards District Office).

(5) Future Systems. The FAA and private industry are developing automatic altimeter setting reporting systems that may include wind and other weather elements. Automatic weather reporting systems will be required to meet FAA and National Weather Service accuracy and reliability standards before they can be used to support instrument flight rule operations.

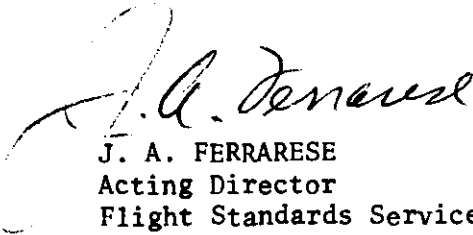
  
J. A. FERRARESE  
Acting Director  
Flight Standards Service

6/16/79

**§ 37.112 Airspeed indicator (pitot static)—  
TSO-C2b.**

(a) *Applicability*—(1) *Minimum performance standards.* Minimum performance standards are hereby established for airspeed indicators which specifically are required to be approved for use in the civil aircraft of the United States. New models of airspeed indicators (pitot static) manufactured for installation on civil aircraft on or after November 1, 1957, shall meet the standards set forth in SAE Aeronautical Standard AS-391B. "Airspeed Indicator (Pitot Static)," dated December 15, 1954.\* Airspeed indicators (pitot static) approved by the Civil Aeronautics Administration prior to November 1, 1957, may continue to be manufactured under the provisions of their original approval.

(b) *Marking.* In lieu of the marking requirement of § 37.7(c) the range shall be shown.

(c) *Data requirements.* With the statement of conformance, one copy of manufacturer's operating instructions, schematic diagrams, and installation procedures shall be furnished the Chief, Engineering and Manufacturing Branch, Flight Standards Division, Federal Aviation Administration, in the region in which the manufacturer is located.

<p>SOCIETY OF AUTOMOTIVE ENGINEERS, Inc. 485 LEXINGTON AVENUE NEW YORK 17, N.Y.</p>	<p><b>AERONAUTICAL STANDARD</b></p>	<p><b>AS 391C</b></p>
<p>AIRSPPEED INDICATOR (PITOT STATIC) (RECIPROCATING ENGINE POWERED AIRCRAFT)</p>		<p>Issued 7-1-47 Revised 11-15-60</p>
<p>1. <u>PURPOSE</u>: To establish the essential minimum safe performance standards for pitot static pressure type of airspeed indicators, primarily for use with reciprocating engine power transport aircraft, the operation of which may subject the instruments to the environmental conditions specified in Section 3.3.</p> <p>2. <u>SCOPE</u>: This Aeronautical Standard covers five basic types of airspeed instruments as follows:</p> <p style="margin-left: 40px;">Type I - 1 revolution Type II - 1 revolution (unequal scale) Type III - 1 1/2 to 1 3/4 revolutions Type IV - 7 revolutions Type V - 1 3/4 to 2 revolutions</p> <p>3. <u>GENERAL REQUIREMENTS</u>:</p> <p>3.1 <u>Material and Workmanship</u>:</p> <p>3.1.1 <u>Materials</u>: Materials shall be of a quality which experience and/or tests have demonstrated to be suitable and dependable for use in aircraft instruments.</p> <p>3.1.2 <u>Workmanship</u>: Workmanship shall be consistent with high-grade aircraft instrument manufacturing practice.</p> <p>3.2 <u>Identification</u>: The following information shall be legibly and permanently marked on the instrument or attached thereto:</p> <p style="margin-left: 40px;">(a) Name of instrument (Airspeed Indicators) (b) SAE AS 391C (c) Manufacturer's part number (d) Manufacturer's serial number or date of manufacture (e) Manufacturer's name and/or trademark (f) Range</p> <p>3.3 <u>Environmental Conditions</u>: The following conditions have been established as minimum design requirements. Tests shall be conducted as specified in Sections 5, 6, and 7.</p> <p>3.3.1 <u>Temperature</u>: When installed in accordance with the instrument manufacturer's instructions, the instrument shall function over the range of ambient temperature of -30C to 50C and shall not be adversely affected by exposure to temperatures of -65C to 70C.</p>		

Section 8.3 of the SAE Technical Board rules provides that: "All technical reports, including standards approved and practices recommended, are advisory only. Their use by anyone engaged in industry or trade is entirely voluntary. There is no agreement to adhere to any SAE standard or recommended practice, and no commitment to conform to or be guided by any technical report, in formulating and approving technical reports, the Board and its Committees shall not investigate or consider patents which may apply to the subject matter. Prospective users of the report are responsible for protecting themselves against liability for infringement of patents."

<b>AS 391C</b>	Issued 7-1-47	AIRSPEED INDICATOR (PITOT STATIC) (RECIPROCATING ENGINE POWERED AIRCRAFT)
	Revised 11-15-60	

3.3.2 Humidity: The instrument shall function and shall not be adversely affected following exposure to any relative humidity in the range from 0 to 95% at a temperature of approximately 70C.

3.3.3 Vibration: When installed in accordance with the instrument manufacturer's instructions, the instruments shall function and shall not be adversely affected when subjected to vibrations of the following characteristics:

<u>Instrument Location in Airframe</u>	<u>Cycles Per Second</u>	<u>Maximum Double Amplitude (In.)</u>	<u>Maximum Acceleration</u>
Panel or Rack (Vibration isolated)	5-50	0.020	1.5g

3.3.4 Altitude: The instrument shall function and shall not be adversely affected following exposure to a pressure and temperature range equivalent to -1000 to 40,000 feet standard altitude, per NACA Report 1235, except as limited by the application of Paragraph 3.3.1. The instrument shall not be adversely affected when subjected to an ambient pressure of 50 inches of mercury absolute.

3.4 Radio Interference: The instrument shall not be the source of objectionable interference, under operating conditions at any frequencies used on aircraft, either by radiation or feed-back, in electronic equipment installed in the same aircraft as the instrument.

3.5 Magnetic Effect: The magnetic effect of the indicator shall not adversely affect the performance of other instruments installed in the same aircraft.

4. DETAIL REQUIREMENTS:

AIRSPPEED INDICATOR (PITOT STATIC)  
 (RECIPROCATING ENGINE POWERED AIRCRAFT)

Issued 7-1-47  
 Revised 11-15-60

**A S 391 C**

- 3 -

4.1 Pressure Equivalents: The instruments shall be calibrated to indicate airspeed in accordance with the following pressure equivalents. (Table I)

TABLE I  
 DIFFERENTIAL PRESSURE - KNOTS AND MPH  
 Mercury at 0°C  
 Water at 15.8°C

Differential Pressures for Knots				Differential Pressures MPH		
Pounds Per Square Inch	Inches of Water	Inches of Mercury	Calibrated Airspeed	Inches of Mercury	Inches of Water	Pounds/Sq. In.
.0094	.261	.0192	20	.0145	.197	.0071
.0377	1.05	.0768	40	.0579	.788	.0284
.0590	1.63	.120	50	.0905	1.23	.0444
.0850	2.35	.173	60	.130	1.77	.0640
.116	3.21	.236	70	.178	2.42	.0872
.151	4.19	.308	80	.232	3.16	.114
.192	5.31	.390	90	.294	4.00	.144
.237	6.56	.482	100	.363	4.94	.178
.342	9.47	.696	120	.524	7.13	.257
.467	12.9	.950	140	.715	9.73	.351
.612	17.0	1.25	160	.936	12.7	.460
.777	21.5	1.58	180	1.19	16.2	.583
.964	26.7	1.96	200	1.47	20.0	.723
1.17	32.5	2.39	220	1.79	24.3	.878
1.40	38.8	2.85	240	2.13	29.1	1.05
1.65	45.8	3.37	260	2.52	34.2	1.24
1.93	53.5	3.93	280	2.93	39.9	1.44
2.23	61.8	4.54	300	3.38	46.0	1.66
2.73	75.6	5.56	330	4.13	56.2	2.03
3.29	91.0	6.69	360	4.95	67.4	2.43
4.13	114.3	8.40	400	6.20	84.3	3.04
5.35	148.2	10.89	450	7.98	108.7	3.92
6.78	187.8	13.80	500	10.06	136.9	4.94
8.44	234.0	17.19	550	12.44	169.3	6.11
10.37	287.4	21.12	600	15.17	206.4	7.45
12.60	349.0	25.64	650	18.27	248.6	8.97
15.14		30.83	700	21.79	296.5	10.70

4.2 Indicating Method: The instruments shall indicate airspeed by means of a pointer moving over a fixed dial. Sensitive types shall have, in addition, an under-dial visible through an aperture in the fixed dial for indicating hundreds of miles per hour, or knots. Clockwise pointer motion shall indicate increasing airspeed.

**AS 391C**

Issued 7-1-47  
Revised 11-15-60

AIRPEED INDICATOR (PITOT STATIC)  
(RECIPROCATING ENGINE POWERED AIRCRAFT)

- 4 -

4.3 Visibility: The pointer and all dial markings shall be visible from any point within the frustum of a cone whose side makes an angle of not less than 30 degrees with the perpendicular to the dial, and whose small diameter is the aperture of the instrument case. The distance between the dial and the cover glass shall be a practical minimum and shall not exceed 0.187 of an inch.

4.4 Dial Markings:

4.4.1 Finish: Unless otherwise specified by the user, Matte White material shall be applied to major graduations, numerals and pointers. Nonfunctional surfaces shall be a durable dull black.

4.4.2 Graduations: Graduations shall be used which will provide maximum dial readability. Where practical minor graduations shall be used at intervals not to exceed 5 miles per hour or 5 knots at applicable and major graduations shall be used at intervals not to exceed 10 miles per hour, or 10 knots.

4.4.3 Numerals: Sufficient numerals shall be marked to positively and quickly identify all graduations. Numerals shall distinctly indicate the graduations to which each applies.

4.4.4 Instrument Name: The word "Airspeed" may be marked and may be the same finish as the numerals. The inscription "MPH" or "KNOTS" may appear on the dial.

4.5 Limitation of Pointer Movements: The pointer movement shall be limited by stops in the mechanism in such a way that the pointer will not be permitted to rotate more than 10 degrees beyond the last graduation on the dial. Stops may also be incorporated in the instrument mechanism to limit counterclockwise motion of the pointer.

4.6 Back of Case Markings: The back of the case, adjacent to the connections, shall be marked as follows:

P - Pitot Pressure Connection  
S - Static Pressure Connection

5. TEST CONDITIONS:

5.1 Atmospheric Conditions: Unless otherwise specified, all tests required by this Aeronautical Standard shall be conducted at an atmospheric pressure of approximately 29.92 inches of mercury and at an ambient temperature of approximately 25C and a relative humidity not greater than 85%. When tests are conducted with the atmospheric pressure or the temperature substantially different from these values, allowances shall be made for the variation from the specified conditions.

5.2 Vibration: (To minimize friction) Unless otherwise specified, all tests for performance may be conducted with the instrument subjected to a vibration of 0.002 to 0.005 inch double amplitude at a frequency of 1500 to 2000 cycles per minute. The term "double amplitude" as used herein, indicates the total displacement from positive maximum to negative maximum.

AIRPEED INDICATOR (PITOT STATIC)  
(RECIPROCATING ENGINE POWERED AIRCRAFT)

Issued 7-1-47  
Revised 11-15-60

**A S 391C**

- 5 -

- 5.3 Preconditioning: No pressure shall be applied to the diaphragm or any actuating element of the instrument, nor shall the diaphragm or other actuating element be flexed or exercised for a period of 24 hours prior to the start of the tests of Section 6.
- 5.4 Vibration Equipment: Vibration equipment shall be used which will provide frequencies and amplitudes consistent with the requirements of Section 3.3.3 with the following characteristics.
- 5.4.1 Circular Motion Vibrations: Vibration equipment shall be such that a point on the instrument case will describe a circle in a plane inclined 45 degrees to the horizontal plane, the diameter of which is equal to the double amplitude specified.
- 5.5 Position: Unless otherwise specified, all tests shall be conducted with the instrument mounted in its normal operation position.
6. INDIVIDUAL PERFORMANCE REQUIREMENTS: All instruments shall be subjected to whatever tests the manufacturer deems necessary to demonstrate specific compliance with this standard including the following requirements where applicable.
- 6.1 Scale Error: The instrument shall be tested for scale errors at approximately 12 essentially equal scale intervals per pointer revolution for Type I, II, III and V. For Type IV, the test shall be made at approximately 17 essentially equal intervals of the entire range. The tests shall be conducted by subjecting the instrument to the pressure specified to produce these readings, first with pressure increasing, then with pressure decreasing. With pressure increasing, the pressure shall be brought up to, but shall not exceed, the pressure specified to give the desired reading. With pressure decreasing, the pressure shall be brought down to, but shall not fall below, the pressure specified to give the desired reading. The errors at the test points shall not exceed the tolerances specified in Table II.
- 6.2 Friction: The instrument shall be tested for friction at approximately four essentially equal scale intervals. The pressure shall be brought up to the desired reading and then held constant while two readings are taken; the first reading being taken before the instrument is vibrated, and the second one after the instrument is vibrated. The difference between any two readings shall not exceed the tolerance in Table III.
- 6.3 Position: A pressure equivalent to one-quarter, one-half and three-quarters scale deflection shall be applied. The change in reading at each deflection produced by rotating the instrument from the dial vertical to the dial horizontal position and 90 degrees to the right and left, while the instrument is vibrated shall not exceed the tolerance specified in Table II.
- 6.4 Leak: With both the pitot pressure and static pressure connections simultaneously evacuated to 15 inches of mercury, the leakage shall not cause more than 0.05 inch of mercury pressure drop during a one minute period. With the static pressure connection open and pressure equivalent to full scale pointer deflection applied to the pitot pressure connection, the leakage shall not cause more than 1 MPH or 1 knot decrease in indication during a one-minute period. This test shall be made with test apparatus containing the minimum practical volume.

**AS 391c**

Issued 7-1-47  
Revised 11-15-60

AIRSPPEED INDICATOR (PITOT STATIC)  
(RECIPROCATING ENGINE POWERED AIRCRAFT)

- 6 -

- 6.5 Dielectric: If applicable, each instrument shall be tested by the method of inspection listed in Paragraphs 6.5.1 and 6.5.2.
- 6.5.1 Insulation Resistance: The insulation resistance measured at 200 volts DC for five seconds between all electrical circuits connected together and the metallic case shall not be less than 5 megohms. Insulation resistance measurements shall not be made to circuits where the potential will appear across elements such as windings, resistors, capacitors, etc., since this measurement is intended only to determine adequacy of insulation.
- 6.5.2 Overpotential Tests: The instruments shall not be damaged by the application of a test potential between electrical circuits, and between electrical circuits and the metallic case. The test potential shall be a sinusoidal voltage of a commercial frequency with an R.M.S. value of five times the maximum circuit voltage, or per Paragraph 6.5.2.1 or 6.5.2.2, whichever applies. The potential shall start from zero and be increased at a uniform rate to its test value. It shall be maintained at this value for five seconds and then reduced at a uniform rate to zero.
- Since these tests are intended to insure proper electrical isolation of the circuit components in question, these tests shall not be applied to circuits where the potential will appear across elements such as windings, resistors, capacitors, etc.
- 6.5.2.1 Hermetically sealed instruments shall be tested at 200 volts R.M.S.
- 6.5.2.2 Circuits that operate at potentials below 15 volts are not to be subjected to overpotential tests.
7. QUALIFICATION TESTS: As many instruments as deemed necessary to demonstrate that all instruments will comply with the requirements of this section shall be tested in accordance with the manufacturer's recommendations.
- 7.1 Low Temperature: The instrument shall be subjected to a temperature of -30C for a period of three hours. With the temperature held at -30C, the instrument shall be tested for scale errors as described in Paragraph 6.1. The errors at the test points shall not exceed the tolerances of Table II by more than the amount specified in Table III.
- 7.2 High Temperature: The instrument shall be subjected to a temperature of 50C for a period of three hours. With the temperature held at 50C, the instrument shall be tested for scale errors as described in Paragraph 6.1. The errors at the test points shall not exceed the tolerances of Table II by more than the amount specified in Table III.
- 7.3 Extreme Temperature Exposure: The instrument shall, after alternate exposures to ambient temperatures of -65C and 70C for periods of 24 hours each and a delay of 3 hours at room temperature following completion of the exposure, meet the requirements of Paragraph 6.1. There shall be no evidence of damage as a result of exposure to the extreme temperatures specified herein.



AIRSPPEED INDICATOR (PITOT STATIC)  
(RECIPROCATING ENGINE POWERED AIRCRAFT)

Issued 7-1-47  
Revised 11-15-60

AS 391C

- 7 -

7.4 Vibration:

7.4.1 Resonance: The instrument, while operating, shall be subjected to a resonant frequency survey of the appropriate range specified in Section 3.3.3 in order to determine if there exists any resonant frequencies of the parts. The amplitude used may be any convenient value that does not exceed the maximum double amplitude and the maximum acceleration specified in Section 3.3.3.

The instrument shall then be subjected to vibration at the appropriate maximum double amplitude or maximum acceleration specified in Section 3.3.3 at the resonant frequency for a period one hour in each axis or with circular motion vibration, whichever is applicable. When more than one resonant frequency is encountered with vibration applied along any one axis, a test period may be accomplished at the most severe resonance, or the period may be divided among the resonant frequencies, whichever shall be considered most likely to produce failure. The test period shall not be less than one-half hour at any resonant mode. When resonant frequencies are not apparent within the specified frequency range, the instrument shall be vibrated for two hours in accordance with the vibration requirements schedule (Section 3) at the maximum double amplitude and the frequency to provide the maximum acceleration.

7.4.2 Cycling: The instrument, while operating, shall be tested with the frequency cycled between limits specified in Section 3.3.3 in 15-minute cycles for a period of one hour in each axis at an applied double amplitude specified in Section 3.3.3 or an acceleration specified in 3.3.3, whichever is the limiting value or a total of three hours for circular motion vibration, whichever is applicable. After completion of this vibration test, no damage shall be evident and the instrument shall meet the applicable requirements of Section 6.

7.5 Seasoning: The instrument shall be subjected to one hundred applications of a differential pressure sufficient to produce approximately full scale deflection. Not less than one hour following this test, the instrument shall be tested for scale errors as described in Paragraph 6.1, except that the scale error test shall not exceed the tolerance specified in Table II by more than the amount specified in Table III.

7.6 Drift: The instrument shall be subjected to a differential pressure sufficient to produce approximately 3/4 scale deflection. After being subjected to the pressure for a period of one hour, the instrument shall be tested as described in Paragraph 6.1 except scale errors shall be determined for increasing pressure only. The reading of the instrument shall not have increased by more than the amount specified in Table III.

7.7 Low Temperature Exposure: The instrument shall be subjected to a temperature of -64C for a period of 24 hours. With the temperature held at -63C, the instrument shall function. In addition, after the temperature is raised to -30C and held for a period of three hours, the instrument shall meet the requirements of Paragraph 7.1.

**AS 391C**

Issued 7-1-47  
 Revised 11-15-60

AIRSPD INDICATOR (PITOT STATIC)  
 (RECIPROCATING ENGINE POWERED AIRCRAFT)

- 8 -

- 7.8 Magnetic Effect: The magnetic effect of the indicator shall be determined in terms of the deflection of a free magnet, approximately 1 1/2 inches long, in a magnetic field with a horizontal intensity of 0.18 (plus or minus 0.01) gauss when the indicator is held in various positions on an east-west line with its nearest part 12 inches from the center of the magnet. With the instrument operating, the maximum deflection of the free magnet shall not exceed 5 degrees from any indicating or reference position.
- 7.9 Humidity: The instrument shall be mounted in its normal operating position (with simulated installation conditions by connecting 10 feet of coiled copper tubing to each connection in such a manner that moisture can drain out the open end) in a chamber maintained at a temperature of 70+2C and a relative humidity of 95+5% for a period of 6 hours. After this period, the heat shall be shut off and the instrument shall be allowed to cool for a period of 18 hours in this atmosphere in which the humidity rises to 100% as the temperature decreases to not more than 38C. This complete cycle shall be conducted once.

Immediately after cycling, there shall be no evidence of damage or corrosion which affects performance. Following this test, the instrument shall be subjected to the scale error at room temperature test of 6.1.

TABLE II  
 TOLERANCES  
 PER CENT FULL SCALE READING

Type I	First 1/2 scale	1.0
	Last 1/2 scale	1.4
Type II	Expanded scale	1.0
	Compressed scale	2.5
Type III	First 1/3 scale	.7
	Last 2/3 scale	1.2
Type IV	First 1/4 scale	.4*
	Middle 2/4 scale	.7
	Last 1/4 scale	.9
Type V	First 360 degrees of scale	.7
	Last 270 degrees of scale	1.4

\*50 knot or mph - .6%

AIRSPED INDICATOR (PITOT STATIC)  
 (RECIPROCATING ENGINE POWERED AIRCRAFT)

Issued 7-1-47  
 Revised 11-15-60

**A S 391c**

- 9 -

TABLE III  
 TOLERANCES  
 PER CENT FULL SCALE READING

TEST	REFERENCE PARAGRAPH	TYPES				
		I	II	III	IV	V
Friction	6.2	1.0	1.2 (expanded scale) 1.2 (compressed scale)	.8	.5	2.7 (1st 1/4 rev.) 2.0 (2nd 1/4 rev.) 1.5 (remainder of scale)
Position	6.3	1.0	1.0	.65	.4	1.7
Vibration	7.3					
Pointer Oscillation		.75	.8	.5	.25	1.5
Pointer Change		.75	.8	.5	.4	1.5
Temperature	7.1	1.2	1.2 (expanded scale) 1.7 (compressed scale)	1.2	.5	1.7 (1st rev.) 2.4 (remainder of scale)
Drift	7.5	.5	.9	.4	.4	No Test
Seasoning	7.4	.75	.6 (expanded scale) .9 (compressed scale)	.5	.4	1.0

PREPARED BY SAE COMMITTEE A-4, AIRCRAFT INSTRUMENTS

**§ 37.118 Rate of climb indicator, pressure actuated (vertical speed indicator)—TSO-C8b.**

(a) *Applicability*—(1) *Minimum performance standards.* Minimum performance standards are hereby established for rate of climb indicators, pressure actuated (vertical speed indicator) which specifically are required to be approved for use on civil aircraft of the United States. New models of rate of climb indicators, pressure actuated (vertical speed indicator) manufactured for installation on civil aircraft on or after April 1, 1959, shall meet the standards set forth in SAE Aeronautical Standard AS-394A, "Rate of Climb Indicator, Pressure Actuated (Vertical Speed Indicator)," dated July 15, 1958,\* with the exceptions listed in subparagraph (2) of this paragraph. Rate of climb indicators, pressure actuated (vertical speed indicator) approved prior to April 1, 1959, may continue to be manufactured under the provisions of their original approval.

(2) *Exceptions.* (i) Conformance with the following sections is not required: 3.1; 3.1.1; 3.1.2; 3.2; 4.2.1.

(ii) Substitute the following for section 7.: "Performance tests: The following tests in addition to any others deemed necessary by the manufacturer, shall be the basis for determining compliance with the performance requirements of this standard."

(b) *Marking.* In lieu of the weight specified in paragraph (c) of § 37.7, the following shall be shown:

(1) Instrument type (I, II, III or IV).

(2) Range (feet per minute climb and descent).

(c) *Data requirements.* With the statement of conformance, one copy each of the manufacturer's operating instructions, schematic diagrams, and installation procedures shall be furnished the Chief, Engineering and Manufacturing Branch, Flight Standards Division, Federal Aviation Administration, in the region in which the manufacturer is located.

SOCIETY OF AUTOMOTIVE ENGINEERS, Inc. 485 LEXINGTON AVENUE NEW YORK 17, N.Y.	<b>AERONAUTICAL STANDARD</b>	<b>AS 394A</b>
RATE OF CLIMB INDICATOR, PRESSURE ACTUATED (VERTICAL SPEED INDICATOR)		Issued 8/1/47 Revised 7/15/58
<ol style="list-style-type: none"> <li>1. <b>PURPOSE:</b> To specify minimum requirements for pressure, actuated Climb Indicators for use in aircraft, the operation of which may subject the instruments to the environmental conditions specified in paragraph 3.3.</li>   <li>2. <b>SCOPE:</b> This Aeronautical Standard covers four (4) basic types of direct indicating instruments as follows:           <ul style="list-style-type: none"> <li>TYPE I - Range 0-2000 feet per minute climb and descent</li> <li>TYPE II - Range 0-3000 feet per minute climb and descent</li> <li>TYPE III - Range 0-4000 feet per minute climb and descent</li> <li>TYPE IV - Range 0-6000 feet per minute climb and descent</li> </ul> </li>   <li>3. <b>GENERAL REQUIREMENTS:</b> <ol style="list-style-type: none"> <li>3.1 <b>Material and Workmanship:</b> <ol style="list-style-type: none"> <li>3.1.1 <b>Materials:</b> Materials shall be of a quality which experience and/or tests have demonstrated to be suitable and dependable for use in aircraft instruments.</li> <li>3.1.2 <b>Workmanship:</b> Workmanship shall be consistent with high-grade aircraft instrument manufacturing practice.</li> </ol> </li> <li>3.2 <b>Identification:</b> The following information shall be legibly and permanently marked on the instrument or attached thereto:           <ol style="list-style-type: none"> <li>a. Name of instrument (Climb Indicator)</li> <li>b. Aeronautical Standard AS-394A</li> <li>c. Manufacturer's part number</li> <li>d. Manufacturer's serial number or date of manufacture</li> <li>e. Manufacturer's name and/or trademark</li> <li>f. Range</li> </ol> </li> <li>3.3 <b>Environmental Conditions:</b> The following conditions have been established as design requirements only. Tests shall be conducted as specified in Section 5, 6 and 7.           <ol style="list-style-type: none"> <li>3.3.1 <b>Temperature:</b> When installed in accordance with instrument manufacturer's instructions, the instrument shall function over the range of ambient temperature of -30C and 50C and shall not be adversely affected by exposure to temperatures of -65C to 70C.</li> <li>3.3.2 <b>Humidity:</b> The instrument shall function and shall not be adversely affected when exposed to any relative humidity in the range from 0 to 95% at a temperature of approximately 32C.</li> </ol> </li> </ol> </li> </ol>		

Section 7C of the SAE Technical Board rules provides that: "All technical reports... ing standards approved and practices recommended, are advisory only. Their use by anyone in the industry... at its advice to SAE standard or recommended practice, and no commitment to conform to or be guided by any technical report in formulating and approving... technical reports, the Board and its Committees will not investigate or consider patents which may apply to the subject matter. Prospective users of the report are responsible for protecting themselves against liability for infringement of patents."

**AS394A**

Issued 8/1/47  
 Revised 7/15/58

**RATE OF CLIMB INDICATOR, PRESSURE ACTUATED  
 (VERTICAL SPEED INDICATOR)**

-2-

3.3.3 Vibration: When installed in accordance with the instrument manufacturer's instructions, the instruments shall function and shall not be adversely affected when subjected to vibration of the following characteristics:

<u>Instrument Location in Airframe</u>	<u>Cycles Per Sec.</u>	<u>Max. Double Amplitude (In.)</u>	<u>Maximum Acceleration</u>
Instrument Panel or Vibration Isolated Mount	5-50	0.020	1.5g

3.3.4 Altitude: The instrument shall function and shall not be adversely affected when subjected to a pressure and temperature range equivalent to -1,000 to 40,000 feet standard altitude, per NACA Report Number 1235, except as limited by the application of paragraph 3.3.1. The instrument shall withstand an external case pressure of 50 inches Hg absolute when installed properly and vented to atmospheric pressure.

3.4 Magnetic Effect: The magnetic effect of the indicator shall not adversely affect the operation of other instruments installed in the same aircraft.

4. DETAIL REQUIREMENTS:

4.1 Indicating Method: Ascent shall be indicated by a clockwise rotation of the pointer from the zero at the 9 o'clock position. Descent shall be indicated by a counterclockwise rotation. Stops shall be incorporated to limit the pointer movement to not more than 178 degrees in each direction from zero.

4.2 Dial Markings:

4.2.1 Finish: Unless otherwise specified by the user, matte white material shall be applied to major graduations, numerals and pointers. Non-functional surfaces shall be a durable dull black.

4.2.2 Graduations: Markings may be provided as follows:

TYPES I AND II - Markings at 100 FPM intervals with major graduations at 500 FPM intervals.

TYPES III AND IV - Markings at 100 FPM intervals up to 2,000 FPM with major graduations at 500 FPM intervals.

4.2.3 Numerals: Sufficient numerals shall be marked to positively and quickly identify all graduations. Numerals shall distinctly indicate the graduations to which each applies.

4.2.4 Instrument Names: Instrument name or function it measures may be legibly indicated in the same finish as applied to the major graduations and numerals.

RATE OF CLIMB INDICATOR, PRESSURE ACTUATED  
(VERTICAL SPEED INDICATOR)

Issued 8/1/47  
Revised 7/15/58

A S 394A

-3-

4.2.5 Visibility: Pointer and dial markings shall be visible from any point within the frustum of a cone, the side of which makes an angle of not less than 30 degrees with the perpendicular to the dial and the small diameter of which is the aperture of the instrument case. The distance between the dial and the cover glass shall be a practical minimum and shall not exceed 0.250 of an inch.

4.3 Zero Setting System: If means for manually setting the pointer at zero is provided, it shall not be accessible in flight.

5. TEST CONDITIONS:

5.1 Atmospheric Conditions: Unless otherwise specified, all tests required by this Aeronautical Standard shall be conducted at an atmospheric pressure of approximately 29.92 inches of mercury and at an ambient temperature of approximately 25C. When tests are conducted with the atmospheric pressure or the temperature substantially different from these values, allowance shall be made for the variation from the specified condition.

5.2 Vibration (to minimize friction): Unless otherwise specified, all tests for performance may be conducted with the instrument subjected to a vibration of 0.002 to 0.005 inch double amplitude at a frequency of 1500 to 2000 cycles per minute. The term double as used herein indicates the total displacement from positive maximum to negative maximum.

5.3 Vibration Equipment: Vibration equipment shall be used which will provide frequencies and amplitudes consistent with the requirements of paragraph 3.3.3 with the following characteristics.

5.3.1 Circular Motion Vibration: Vibration equipment shall be such that a point on the instrument case will describe in a plane inclined 45 degrees to the horizontal plane, a circle, the diameter of which is equal to the double amplitude specified.

5.4 Position: Unless otherwise specified, all tests shall be made with the instrument mounted in its normal operating position.

6. INDIVIDUAL PERFORMANCE REQUIREMENTS: All instruments shall be subjected to whatever tests the manufacturer deems necessary to demonstrate specific compliance with this aeronautical standard including the following requirements where applicable.

6.1 Zero Setting Range: The range of movement of the pointer by means of the zero adjustment shall not be less than 400 feet per minute for the "Up" and "Down" position.

6.2 Scale Error: When subjected to the rates of change of pressure indicated in Table I for the altitude intervals shown, the errors shall not exceed the tolerances specified.

<b>AS 394A</b>	Issued 8/1/47 Revised 7/15/58	RATE OF CLIMB INDICATOR, PRESSURE ACTUATED (VERTICAL SPEED INDICATOR)
<p>-4-</p> <p>6.3 <u>Lag</u>: The natural lag of the instrument when timed between the following points shall be between 3 and 15 seconds.</p> <p>TYPE I AND II - 1800 - 200 feet per minute TYPE III AND IV - 2000 - 200 feet per minute</p> <p>6.4 <u>Friction</u>: A test shall be performed to ascertain friction. In the time intervals at which the lag times were measured, the pointer shall move smoothly towards zero (while no vibration is applied) and shall return to zero within 300 feet of the initial reading.</p> <p>6.5 <u>Leak</u>: With a suction of 15 inches of mercury applied to the static pressure connection, the leakage shall not cause more than 0.05 inches of mercury pressure drop during a 1 minute period. With a pressure of 10 inches of mercury applied to the static connection, the leakage shall not cause more than 0.05 inches of mercury pressure drop during a 1 minute period.</p> <p>6.6 <u>Position Error</u>: With atmospheric pressure applied to the instrument, the difference between the pointer indication when the instrument is in normal operating position and when it is in any other position shall not exceed 50 feet per minute.</p> <p>7. <u>QUALIFICATION TESTS</u>: As many instruments as deemed necessary, to demonstrate that all instruments will comply with the requirements of this section, shall be tested in accordance with the manufacturers' recommendations.</p> <p>7.1 <u>Low Temperature</u>: The instrument shall be exposed to a temperature of -30C for 3 hours and while at this temperature shall be subjected to the rates of change of pressure indicated in Table II for the altitude intervals shown. The errors shall not exceed the tolerances specified in Table II.</p> <p>7.2 <u>Extreme Temperature Exposure</u>: The instrument shall, after alternate exposures to ambient temperatures of -65C and 70C for periods of 24 hours each and a delay of 3 hours at room temperature following completion of the exposure, meet the requirements of paragraphs 6.2, 6.3 and 6.4. There shall be no evidence of damage as a result of exposure to the extreme temperatures specified herein.</p>		



RATE OF CLIMB INDICATOR, PRESSURE ACTUATED  
(VERTICAL SPEED INDICATOR)

Issued 8/1/47  
Revised 7/15/58

A S 394A

-5-

- 7.3 Vibration: The instrument shall be subjected to a resonant frequency survey of the appropriate range specified in paragraph 3.3.4 in order to determine if there exists any resonant frequencies of the parts. The amplitude used may be any convenient value that does not exceed the maximum double amplitude and the maximum acceleration specified in paragraph 3.3.4.

The instrument shall then be subjected to vibration at the appropriate maximum double amplitude or maximum acceleration specified in paragraph 3.3.4 at the resonant frequency for a period of one (1) hour with circular motion vibration. When more than one (1) resonant frequency is encountered, a test period may be accomplished at the most severe resonance, or the period may be divided among the resonant frequencies, which shall be considered most likely to produce failure. The test period shall not be less than one-half hour at any resonant mode. When resonant frequencies are not apparent within the specified frequency range, the instrument shall be vibrated for two (2) hours in accordance with the vibration requirements' schedule (Section 3) at the maximum double amplitude and the frequency to provide the maximum acceleration.

While the instrument is being vibrated, the drift of the pointer shall not exceed 50 feet per minute and it shall not oscillate more than 50 feet per minute.

After completion of the exposure no damage shall be evident and the instrument shall meet the requirements of paragraph 6.2, 6.3 and 6.4.

- 7.4 Overpressure: After subjecting the instrument to rates of 20,000 feet per minute ascent and 30,000 feet per minute descent, within a 5 minute period the pointer shall return to its original indication within 100 feet per minute.
- 7.5 Magnetic Effect: The magnetic effect of the instrument shall be determined in terms of the deflection of a free magnet, approximately 1-1/2 inches long, in a magnetic field with a horizontal intensity of  $0.18 \pm 0.01$  gauss, when the indicator is held in various positions on an east-west line with its nearest part 12 inches from the center of the magnet. (An aircraft Compass with the compensating magnets removed therefrom may be used as the free magnet for this test.) The maximum deflection of the magnet shall not exceed 5 degrees.
- 7.6 Humidity: The instrument shall be mounted in its normal operating position (with simulated installation conditions by connecting 10 feet of coiled copper tubing to the pressure connection in such a manner that moisture can drain out the open end) in the chamber maintained at a temperature of  $70 \pm 2C$  and a relative humidity of  $95 \pm 5\%$  for a period of six (6) hours. After this period, the heat shall be shut off and the instrument shall be allowed to cool for a period of 18 hours in this atmosphere in which the humidity rises to 100% as the temperature decreases to not lower than  $38C$ . This complete cycle shall be conducted once.

Immediately after cycling, the instrument shall be tested and shall meet the requirements of Section 6.

**AS394A**

Issued 8/1/47  
 Revised 7/15/58

**RATE OF CLIMB INDICATOR, PRESSURE ACTUATED  
 (VERTICAL SPEED INDICATOR)**

-6-

TABLE I

SCALE ERROR TOLERANCE

TYPES I and II

(Ranges: 0-2,000 and 0-3,000 Feet Per Minute)

	<u>Standard Altitude Test Interval Feet</u>	<u>Test Rate Ascent and Descent Feet Per Minute</u>	<u>Tolerance Feet Per Minute</u>
Between	2,000 to 2,500	500	35
	2,000 to 3,000	1,000	75
	2,000 to 3,500	1,500**	150
	2,000 to 4,000	2,000	250
Between	15,000 to 16,500	1,500**	200
	15,000 to 17,000	2,000	250
Between	28,000 to 29,500	1,500**	200
	28,000 to 30,000	2,000	250

\*\* Maximum test point for Type I.

TYPES III and IV

(Ranges: 0-4,000 and 0-6,000 Feet Per Minute)

	<u>Standard Altitude Test Interval Feet</u>	<u>Test Rate Ascent and Descent Feet Per Minute</u>	<u>Tolerance Feet Per Minute</u>
Between	2,000 to 2,500	500	100
	2,000 to 3,000	1,000	200
	2,000 to 4,000	2,000	300
	2,000 to 5,000	3,000**	300
	2,000 to 6,000	4,000	400
	2,000 to 7,000	5,000	500
Between	15,000 to 17,000	2,000**	300
	15,000 to 17,000	4,000	400
Between	28,000 to 30,000	2,000**	300
	28,000 to 32,000	4,000	400

\*\* Maximum test point for Type III.

RATE OF CLIMB INDICATOR, PRESSURE ACTUATED  
 (VERTICAL SPEED INDICATOR)

Issued 8/1/47  
 Revised 7/15/58

A S394A

-7-

TABLE II  
 SCALE ERROR  
LOW TEMPERATURE TOLERANCE

TYPES I and II  
 (Ranges: 0-2,000 and 0-3,000 Feet Per Minute)

Standard Altitude Test Interval Feet	Test Rate Ascent and Descent Feet Per Minute	Tolerance Feet Per Minute
Between 2,000 to 3,500	1,500	200
Between 28,000 to 29,500	1,500	250

TYPES III and IV  
 (Ranges: 0-4,000 and 0-6,000 Feet Per Minute)

Standard Altitude Test Interval Feet	Test Rate Ascent and Descent Feet Per Minute	Tolerance Feet Per Minute
Between 2,000 to 4,000	2,000**	300
2,000 to 6,000	4,000	400
Between 28,000 to 30,000	2,000**	300
28,000 to 32,000	4,000	400

\*\* Test Point for Type III.

NOTE: Tables I and II have been changed in accordance with Military format; i.e., the values have not been changed.

**§ 37.145 Maximum allowable airspeed indicator systems—TSO-C46a.**

(a) *Applicability.* This technical standard order prescribes the minimum performance standards that maximum allowable airspeed indicator systems must meet in order to be identified with the applicable TSO marking. New models of the instrument that are to be so identified, and that are manufactured on or after the effective date of this TSO, must meet the requirements of the "Federal Aviation Administration Standard, Maximum Allowable Airspeed Indicator Systems", set forth at the end of this section.

(b) *Marking.* In addition to the markings required by § 37.7, the instrument must be marked to indicate its range in knots, and, if applicable, to identify the calibration employed to control the movement of the maximum allowable airspeed pointer in the  $V_{MO}$  and  $M_{MO}$  ranges, or to identify the particular aircraft type design on which the instrument is intended to be used.

(c) *Data requirements.* In accordance with § 37.5, the manufacturer must furnish the Chief, Engineering and Manufacturing Branch, Flight Standards Division, Federal Aviation Administration, in the region in which the manufacturer is located, the following technical data:

(1) Seven copies of the manufacturer's operating instruction, equipment limitations, and installation procedures.

(2) One copy of the test report of the manufacturer.

(d) *Previously approved equipment.* Maximum allowable airspeed indicator models approved prior to the effective date of this section may continue to be manufactured under the provisions of their original approval.

**FEDERAL AVIATION ADMINISTRATION STANDARD**  
**Maximum Allowable Airspeed Indicator Systems**

**1. Purpose.**

This document specifies minimum performance standards for pitot-static type, maximum allowable airspeed indicator systems which indicate continuously both indicated airspeed and maximum allowable airspeed.

**2. Performance Requirements.**

**2.1 General.**

(a) *Materials.* Materials must be of a quality demonstrated to be suitable and dependable for use in aircraft instruments.

(b) *Environmental conditions.* The instrument must be capable of performing its intended function and not be adversely affected during or following prolonged exposure to the environmental conditions stated under section 3. Where optional environmental conditions are set forth, the conditions selected must be declared as equipment limitations.

**2.2 Detail requirements.**

(a) *Indicating means.* Indicated airspeed and maximum allowable airspeed must be displayed in such a manner that the numerical values on the scale increase in a clockwise, left to right, or bottom to top direction.

(b) *Case markings.* The outlets in the case must be marked with "P" for the pitot pressure connection, and with "S" for the static pressure connection.

**2.3 Design requirements.**

**(a) Adjustable settings.**

(1) *Maximum allowable airspeed pointer.* An adjustable stop may be provided in the instrument for limiting the movement of the maximum allowable airspeed pointer. If included, the design of this adjustment must be such that it will not affect the indication of the pointer when the altitude pressure conditions and Mach Number setting are such that the limiting speed will be lower than that set by the adjustable stop.

(2) *Mach Number.* If a readily accessible means is provided for setting the instrument to any desired Mach Number, the value of the setting must be visible from the front of the instrument. When the instrument does not contain an external Mach Number setting adjustment, the value of the permanent Mach Number setting need not be visible from the front of the instrument.

(b) *Visibility.* The indicating means and all markings must be visible from any point within the frustum of a cone, the side of which makes an angle of at least 30° with the perpendicular to the dial and the small diameter of which is the aperture of the instrument case. The distance between the dial and the cover glass must be a practical minimum.

**(c) Calibration.**

(1) *Indicated airspeed pointer.* The indicated airspeed pointer must indicate airspeed in accordance with the values contained in Table I.

(2) *Maximum allowable airspeed pointer.* The maximum allowable airspeed pointer must indicate maximum allowable airspeed values in the  $V_{MO}$  and  $M_{MO}$  limit ranges which—

(i) Follow the standard fundamental relationships of subsonic compressible flow gas dynamics which are stated in appendix A: or

(ii) Are adjusted to account for design factors that are characteristic of a particular aircraft type design such as, but not limited to, static source pressure error variations and variable speed limitations with altitude.

(d) *Scale error.*

(1) *Instruments with permanent Mach Number setting.* The indicated airspeed scale error and the maximum allowable airspeed scale error must not exceed the tolerances specified in Tables I and II, respectively, with the instrument set at its permanent Mach Number.

(2) *Instruments with means for external Mach Number setting adjustment.*

(i) The indicated airspeed scale error must not exceed the tolerances specified in Table I with the instrument set at the lowest Mach Number.

(ii) The maximum allowable airspeed scale error must not exceed the tolerances specified in Table II with the instrument set at the lowest Mach Number and at increasing Mach Number setting of not more than 0.10 to and including the maximum Mach Number.

(e) *Hysteresis.* The reading of the maximum allowable airspeed pointer first at 30,000 feet altitude and then at 10,000 feet altitude must not differ by more than 2 knots from the corresponding readings obtained for increasing altitudes during tests to assure the instrument complies with the scale error requirements of section 2.3(d)(2)(ii) of this TSO.

(f) *After effect.* To assure the instrument complies with the scale error requirements of section 2.3(d)(2)(ii) of this TSO, the maximum allowable airspeed pointer must return to its original readings, corrected for any change in atmospheric pressure, within 3 knots, after not less than 1 or more than 5 minutes have elapsed following completion of performance tests.

(g) *Friction.*

(1) *Maximum allowable airspeed pointer.* The friction of the pointer must not produce an error exceeding 4 knots at each point indicated by an asterisk in Table II.

(2) *Indicated airspeed pointer.* The friction of the pointer must not produce an error exceeding 3 knots at each point indicated by an asterisk in Table I.

(h) *Leak.*

(1) *Case leak.* When subjected to a static pressure differential of 15 inches of mercury between the inside and outside of the case, the internal pressure must not increase because of case leaks more than 0.05 inches of mercury at the end of 1 minute time following first application of the differential pressure.

(2) *Airspeed diaphragm leak.* There must not be any apparent movement of the indicated airspeed pointer for 1 minute after a sequence of events in which pressure sufficient to produce full scale deflection of the indicated airspeed pointer is applied to the pitot connection (static pressure connection open to atmosphere), the pressure source is stopped, and the connection tubing pinched.

**3. Environmental Conditions.**

**3.1 Temperature.** The instrument must perform its intended function over the range of ambient tem-

perature from  $-30^{\circ}$  to  $50^{\circ}$  C. With the instrument temperature stabilized at the limits of the range, the scale error must not exceed by more than 4.5 knots the tolerances specified in Tables I and II at the points marked with an asterisk. The instrument must not be adversely affected by exposure to the range of ambient temperature from  $-65^{\circ}$  to  $70^{\circ}$  C.

**3.2 Altitude.** The instrument must perform its intended function and must not be adversely affected when operating in the pressure range from  $-1,000$  feet and the maximum altitude of intended operation. The instrument must withstand an external case pressure of 50'' Hg. absolute when installed properly and vented to an atmospheric pressure of approximately 29.92'' Hg. absolute.

**3.3 Vibration.** The instrument must perform its intended function and must not be adversely affected when subjected to vibrations of the following characteristics:

Instrument panel mounted (vibration isolated)	Frequency cycles per second	Maximum double amplitude (inches)	Maximum acceleration
Reciprocating engine powered aircraft-----	5-50	0.020	1.5g
Turbine engine powered aircraft-----	5-55 55-1000	0.020	----- 0.25g

**3.4 Humidity.** The instrument must perform its intended function and must not be adversely affected following exposure to the extreme condition of relative humidity in the range from 0 to 95 percent at a temperature of approximately  $70^{\circ}$  C. for a period of 10 hours.

**4. Compliance Tests.**

As evidence of compliance with this standard, the manufacturer must perform evaluation tests on prototype instruments to demonstrate proper design, reliability in performance of its intended functions, and conformity with the performance standards of section 2. Tests must also be performed to demonstrate compliance with the environmental condition requirements specified in section 3.

**5. Individual Performance Tests.**

The manufacturer must conduct such tests as may be necessary on each instrument to assure that it will meet the minimum performance requirements of sections 2.3(b) through 2.3(h).

TABLE I

Speed knots	Impact pressure (qc) Inches Hg at 25° C.	Tolerance knots
50	0.1198	± 4.0
*60	.1727	2.0
80	.3075	2.0
*100	.4814	2.0
120	.6950	2.0
*150	1.091	2.5
180	1.580	3.0
*200	1.959	3.0
230	2.610	3.0
*250	3.100	3.0
280	3.924	3.5
*300	4.534	3.5
320	5.195	3.5
*350	6.286	4.0
370	7.082	4.5
*400	8.385	5.0
430	9.826	5.5
*450	10.87	6.0
480	12.56	7.0
*500	13.78	7.0
520	15.07	7.0
*550	17.16	8.5
570	18.66	8.5
*600	21.07	9.0
630	23.71	9.5
*650	25.59	10.0

TABLE II

Altitude feet	Pressure inches mercury	Maximum speed pointer tolerance ± knots	
0	29.921	**4	
*5,000	24.896		
10,000	20.577		
*15,000	16.886		
20,000	13.750		
*25,000	11.104		
30,000	8.885		
*35,000	7.041		
40,000	5.538		
*45,000	4.355		
50,000	3.425		**4

\*\*From indicated airspeed corresponding to maximum equivalent airspeed or maximum mach whichever is the limiting factor.

APPENDIX A

Relationships For Calibrating Maximum Allowable  
Airspeed Pointer

(1) For altitudes from sea level to altitude where

$$V_{MO} = C_{\alpha} \sqrt{\frac{2}{k-1} \left\{ 1 + \frac{P}{P_0} \left[ \left( \frac{V_M}{C_{SO}} + 1 \right)^{\frac{k}{k-1} - 1} \right] \right\}^{\frac{k-1}{k-1}}}$$

(2) For altitudes where  $M_{MO}$  is limiting factor:

$$V_{MO} = C_{\alpha} \sqrt{\frac{2}{k-1} \left\{ \frac{P}{P_0} \left[ \left( 1 + \frac{k-1}{2} M_{MO}^2 \right)^{\frac{k}{k-1} - 1} \right] + 1 \right\}^{\frac{k-1}{k-1}}}$$

Where:

$V_{MO}$  = Maximum allowable indicated airspeed in knots.

$M_{MO}$  = Maximum allowable mach.

$k$  = Ratio of specific heats = 1.40 for air.

$P_0$  = Pressure at sea level in inches of Hg.

$P$  = Ambient static pressure in inches of Hg.

$C_{SO}$  = Speed of sound at sea level = 661.48 knots.

$\alpha$  = Density ratio at altitude.

$V_M$  = Maximum equivalent airspeed in knots.