

INDEX

<i>Sl.No.</i>	<i>Particular</i>	<i>Page No.</i>
1	SECTION-I Invitation of domestic competitive Bidding	01 - 05
2	SECTION-II Instruction to Bidder	06 - 21
3	SECTION-III General Terms & Conditions of Contract	21 - 38
4	SECTION-IV Technical Specification	39 - 56
5	SECTION-V Schedule of Bid	57
6	BLANK	58



SECTION-I

NIT NO. AGM (DP&C)/R-APDRP/Part-B/EC-II/2013-14/24 **Dated** The 16th April, 2013.

NOTICE INVITING COMPETITIVE BIDDING / TENDER FOR PROCUREMENT OF STEEL TUBULAR POLES FOR IMPLEMENTATION OF R-APDRP (PART-B) SCHEME UNDER BADHARGHAT, JOGENDRANAGAR, PRATAPGARH, INDRANAGAR, SONAMURA PROJECT AREA.

1.0 INTRODUCTION

Additional General Manager (DP&C), Corporate Office, TSECL, Bidyut Bhavan, Agartala, Tripura invites Three-Parts sealed tender on behalf of TSECL from the resourceful and experienced Manufacturer-cum-Supplier/Local SSI Entrepreneurs of Tripura for supply of following materials FOT at **Store yard of the DEPUTY GENERAL MANAGER, Electrical Division No – I11, Agartala** under the AGM, Electrical Circle No-II, Agartala.

Sl. No.	Description of item. N.I.T. No.	Estimated cost. Earnest money	Last date of Bid receiving.	Cost of Tender Paper (Rs.).	Time of completion
1.	2.	3.	4.	5.	6
1.	Procurement of Steel Tubular Poles (9.0 Mtr. & 11.0 Mtr.) conforming to ISS: 2713(P-I & II)/1980 as amended up-to-date and other relevant IS with up-to date amendments and as per TSECL's tender specification enclosed.	<u>Rs.5,42,90,460.00</u> Rs. 5,00,000.00	13.5.2013	Rs.5,000.00	6 (Six) months

Three part tender consists of the following and shall be opened sequentially.

- i. Pre-Qualification Bid.**
- ii. Technical Bid**
- iii. Commercial Bid.**

2.0 SCOPE OF WORK

Scope of work covered under this package includes Design, Engineering, Manufacture, Assembly, and Inspection, Testing at manufacturer's works before



dispatch, Packing, Supply and Delivery & Transportation FOT at **Store yard of the . DEPUTY GENERAL MANAGER. Electrical Division NO-III, Agartala** under the AGM, Electrical Circle No-II, Agartala freight & insurance, loading, unloading & stacking of materials as per approved technical specification in this tender document.

3.0 Scope of work given above is only indicative. The detailed scope has been described in the **Schedule of Supply** in **SECTION-V** attached with this bidding document.

4.0 Pre- Qualification Bid

The first part shall be Pre-Qualification Bid consisting of the following documents in sealed envelope:-

- i. The bidder shall be required to deposit **Earnest Money @ 2.5 %** of the estimated cost put to tender subject to maximum of **Rs. 5.00 Lakhs** in the shape of **Demand Draft** from any scheduled bank guaranteed by Reserve Bank of India favouring **TRIPURA STATE ELECTRICITY CORPORATION LIMITED** payable at **Agartala** along with the bid in a separate sealed envelope. The earnest money deposited is adjustable with **Contract Performance Guarantee**.
- ii. **Exemption certificate** for EMD in case of Local SSI units if applicable shall have to be submitted along with the BID document..
- iii. The Bidder/Supplier shall be required to furnish **Performance Certificate (duly attested by Government Officers/Notary)** of executing supply of similar materials to different reputed Power Utilities/Discoms/SEBs by them as manufacturer-cum supplier for at least 25% value & quantity of the estimated cost & quantity put to this NIT during the last 5(five) years.
- iv. Photo copy of **Manufacturer(s) Registration Certificate issued by the Dept. of Industries** duly attested by Govt. Officials / Notary.
- v. Photo copy of **PAN Card** and **VAT Registration Certificate** duly attested by Govt. Officials / Notary.
- vi. **Tax Clearance Certificate (TCC)** of current validity shall be attached (for Local Vendors only).
- vii. Certified copy of **Audited Balance Sheet** (by Chartered Accountant) of the bidder in support of annual turnover for the last 3 (three) years.
- viii. Photo copy of eligibility certificate for getting procurement preference benefit against the SSI registered firm must be accompanied with the bid document as per norms of the State Govt matching with TSECL purchase policy (**15% w.r.t 1st lowest rate of outside bidder**) for evaluation of tender on production of document/certificate issued by the Dept. of Industries, Govt of Tripura.
- ix. The credential of the participants with reference to quality of recent / past supplies to TSECL will be considered as a criterion among others.
- x. In the event of any intending bidder found as debarred by any power utility participating in bidding / supplying process of similar materials for whatever reasons, TSECL reserves the right for examination / scrutiny of such offer and to take necessary action leading to rejection of the offer.
- xi. Notwithstanding anything contained herein above, the TSECL reserves the right to assess the capacity and capability of bidder to execute the work.



xii. **Bids submitted without documents** as indicated above will be treated as **disqualified.**

5.0 The tender form can be seen and downloaded from the website www.tenders.gov.in www.tripurainfo.com and TSECL's official website www.tsecl.nic.in . All the proposals shall be separately sealed with the inscription of proposal (bid) along with tender reference. The offers containing all three proposals shall be sealed in a big envelope with the NIT No. & date of opening schedule and to be submitted within date specified and shall be opened sequentially in presence of authorized representative of intending bidders.

5.1 Tender will be received only at **Office of the Additional General Manager (DP&C), Corporate Office, TSECL, Bidyut Bhaban, Agartala, Tripura** up to 1.00 Pm. The pre-qualification bid shall be opened at 3.30 pm on the same day if possible; otherwise the pre-qualification bid shall be opened on the next working day. The technical bid will be opened only after finalization of the pre-qualification bid. Successful Bidder(s) in the pre-qualification segment shall only be allowed for consideration of technical bid offer. In technical bid offer the bidder has to qualify the requirement of technical parameters of the NIT. Only the successful bidders in technical bid segment shall be allowed for their commercial bid offer. Tender without earnest money (to be deposited in the form of, Bank Draft on any nationalized / schedule Bank payable at Agartala) shall be liable for rejection. No tender submitted or received through post after the fixed date and time will be entertained.

(In case the above scheduled last date for receiving of tender against any N.I.T. is declared holiday by the State Government tender(s) in response to the said N.I.T. will be received up to 1.00 Pm on the next working day keeping other clauses of N.I.T. unchanged.)

5.2 The bidder shall bear all cost and expenses associated with purchase and submission of its bid including post bid discussions, technical & other presentation etc., and TSECL will in no case be responsible or liable for those cost, regardless of the conduct or outcome of the bidding process.

5.3 The bidder shall furnish documentary evidence in support of the qualifying requirements stipulated above along with their bid. Bid received without such documents shall be summarily rejected.

5.4 Tender form can be downloaded from the website www.tenders.gov.in www.tripurainfo.com and TSECL's official website www.tsecl.nic.in and the cost of the tender form shall be as in 1.0 of this section which shall be deposited in the form of Demand Draft on any Nationalized/Scheduled bank payable at Agartala in favour of the **Additional General Manager (DP&C), Corporate Office, TSECL, Bidyut Bhaban, Agartala, Tripura.**

5.5 The downloaded tender document in undamaged condition shall be signed by the tenderer/ bidder on all pages and will be enclosed with the commercial bid. All corrections to rates and items in the tender should be initialed by the tenderer/bidder. Every pages of the rate schedule be signed in full by the tenderer/bidder. **The bidders/tenderers must quote their rates in the prescribed price bidding schedule in the bidding document.**

The Bidder shall have to give a DECLARATION that he /they have gone through the details of the bidding document as per format appended.



- 5.6 Canvassing in connection with tenders / uncalled for remarks by the tenderer will lead the tender to summarily reject.
- 5.7 **The whole supply may be split up between two or more bidders or accepted in part and not in entire, if considered expedient.**
- 5.8 The contract agreement shall commence from the date of issue of supply order/LOA and the period for delivery of materials shall be reckoned from the **7th day of issue of supply order/LOA.**
- 5.9 Before submitting tenders, the tenderers are to satisfy themselves by actual site visit where supply of materials shall be unloaded/stacked as regards the prevailing conditions of approaches and roads and availability of labourers and materials etc. and tenderers submitting tender shall be deemed to have done so. No claim on the above will be entertained afterwards.
- 5.10 The tender for supply of materials shall remain open for **acceptance for a period of 180 (One Eighty) days from the date of opening of tender.** If any tenderer withdraws his tender before the said period or makes any modifications in the terms and conditions of the tender which are not acceptable to the TSECL, the TSECL shall without prejudice to any other right or remedy be at liberty to forfeit the said earnest money absolutely.
- 5.11 **Power of Attorney, if given to authorized signatory for signing the Contract Agreement, shall be made in an INDIA NON-JUDICIAL STAMP OF Rs.100.00 (Rupees one hundred)only.**
- 5.12 The bidding documents are not transferable and cost of bidding document is not refundable under any circumstances.
- 6.0 OWNER'S RIGHT TO ACCEPT ANY BID AND TO REJECT ANY OR ALL BIDS**
- 6.1 TSECL reserves the right to accept or reject any bid, and to annul the bidding process and reject all bids at any time prior to award of contract, without thereby incurring any liability to the affected Bidder or Bidders or any obligation to inform the affected Bidder or Bidders of the grounds for such action.
- 7.0 Contract Performance Guarantee:**
The successful bidder(s) shall furnish a Contract Performance Guarantee (CPG) @ 10% of the total contract value for a period of 24(twenty four) months plus delivery period of 6(six) months(CPG is to be extended further subject to actual delivery period) in the following manner:-
- i. Only 50% of **Contract Performance Guarantee** amount shall be deposited in the shape of **Bank Guarantee** as per TSECL's format favouring TSECL on any Nationalized Bank and balance 50% shall be deposited in the shape of **Demand Draft** on any Nationalized Bank favouring **TRIPURA STATE ELECTRICITY CORPORATION LIMITED** payable at Agartala, West Tripura or shall be deducted on pro-rata basis from R/A Bills.

Or



- ii. Total **Contract Performance Guarantee** amount shall be deposited in the shape of **Demand Draft** on any Nationalized Bank favouring **TRIPURA STATE ELECTRICITY CORPORATION LIMITED** payable at Agartala, West Tripura.

Or

- iii. CPG amount shall be deducted on pro-rata basis from R/A Bills.

EMD deposited during bid will be merged/adjustable with the eligible Contract Performance Guarantee (CPG) for each of above case.

8.0 Address for communication:

**Additional General Manager (DP&C)
Tripura State Electricity Corporation Limited
Corporate Office, Bidyut Bhaban
Agartala, Tripura (West).
PIN: 799001
Ph: 0381 230 7433, Tele Fax: 0381 232 5345.**



SECTION-II

INSTRUCTION TO BIDDERS

1.0 GENERAL INSTRUCTIONS

The bidders are to satisfy themselves by actual site visit to the site of materials (F.O.T.) as regards the prevailing condition of approaches, transportation facilities availability of labourers and availability of materials etc. before submission of bid. No claim on this account will be entertained at any stage.

The location of the Store materials at Store yard of the **DEPUTY GENERAL MANAGER. Electrical Division NO-III, TSECL, Agartala** at a distance of about 2K.M. from Agartala, the nearest railway station in Tripura. The materials also may be transported by road transport through the **National Highway – 44** at a distance of about 2KM.

2.0 COST OF BIDDING

The Bidder shall bear all the costs and expenses associated with preparation and submission of its Bid including post-bid discussions, technical and other presentation etc. and the TSECL shall in no case be responsible or liable for those costs, regardless of the conduct or outcome of the bidding process.

3.0 THE BIDDING DOCUMENT

3.1 CONTENTS OF BIDDING DOCUMENTS

The goods and services required, bidding procedures and contract terms are as prescribed in the Bidding Documents.

In addition to the Invitation for Bids, the Bidding Document is a compilation of the following sections:

A] Section - I: - Notice Inviting Tender

B] Section - II: - Instructions to Bidders

C] Section -III: - General Terms & Conditions of Contract.

D] Section -IV: - Technical Specification.

E] Section - V: - Price bidding schedule.

3.2 UNDERSTANDING OF BIDDING DOCUMENTS

A prospective Bidder is expected to examine all instructions, forms, terms and specifications in the Bidding Documents and fully inform himself as to all the conditions and matters which may in any way affect the scope of work or the cost thereof. Failure to furnish all information required by the Bidding Documents or submission of a Bid not substantially responsive to the Bidding Documents in every respect shall be at the Bidder's risk and may result in the rejection of its Bid.



4.0 CLARIFICATIONS ON BIDDING DOCUMENTS

- 4.1 A prospective Bidder finds discrepancies or omissions in the specifications and documents or is in doubt as to the true meaning of any part or requires any clarification on Bidding Documents should make the request / notify the tender inviting authority of TSECL in writing. The concerned authority of TSECL shall respond in writing to any request for such clarification of the Bidding Documents, which it receives not later than fifteen (15) days prior to the deadline for submission of bids stipulated in tender notice. Written copies of the response (including an explanation of the query but without identifying its source) shall be sent to all prospective bidders who purchased the tender document.
- 4.2 Verbal clarification and information given by the Owner or his employee(s) or his representative (s) shall not in any way be binding on the Owner.

5.0 AMENDMENT TO BIDDING DOCUMENTS

- 5.1 At any time prior to the deadline for submission of bids, TSECL may, for any reason, whether at its own initiative or in response to a clarification requested by a prospective Bidder, modify the Bidding Documents by amendment(s).
- 5.2 The amendment shall be notified in writing or by telex or cable to all prospective Bidders, who have received the Bidding Documents at the address contained in the letter of request for issue of Bidding Documents from the Bidders. TSECL shall bear no responsibility or liability arising out of non-receipt of the same in time or otherwise.
- 5.3 In order to afford prospective bidders reasonable time to take the amendment into account in preparing their bids, TSECL may, at its discretion, extend the deadline for submission of bids.
- 5.4 Such amendments, clarifications, etc shall be binding on the bidders and shall be given due consideration by the bidders while they submit their bids and invariably enclose such documents as a part of the Bid.

6.0 PREPARATION OF BIDS

6.1 LANGUAGE OF BID

The Bid prepared by the Bidders and all correspondence and documents relating thereto, exchanged by the Bidder and TSECL, shall be written in English language, provided that any printed literature furnished by the bidder may be written in another language so long as accompanied by an English translation of its pertinent passages. Failure to comply with this may disqualify a bid.

7.0 LOCAL CONDITIONS

- 7.1 It shall be imperative on each bidder to fully inform him of all local conditions and factors, which may have any effects on the execution of the contract covered under these documents and specifications. The Owner shall not entertain any request for clarification from bidders, regarding such local conditions.



- 7.2 It must be understood and agreed that such factors have properly been investigated and considered while submitting the proposals. No claim for financial adjustment to the Contract awarded under these specifications and documents shall be entertained by TSECL. Neither any change in the time schedule of the Contract nor any financial adjustments arising thereof shall be permitted by TSECL.

8.0 DOCUMENTS COMPRISING THE BID

The Bid shall be submitted in **3 (three) parts in separate sealed envelopes properly super scribing tender no., name of work and bid opening date** as follows:

1st Part: PRE-QUALIFICATION BID.

- i. Containing **Bid Earnest Money** as per the stipulations of the Bid Documents in a separate sealed envelope.
- ii. Containing Documentary Evidence of the Bidder fulfilling the **Qualifying Requirements** stipulated in the NIT / BID Document as indicated at Clause 4.0 of Section-I of the tender document. The Bidder shall also submit all such other documents deemed necessary in support of their meeting the stipulated qualifying requirement and its credentials.

2nd Part: TECHNICAL BID

The Technical Bid shall be consisting of all technical details, data sheet, drawings and detail technical specification for the item offered. The technical bid will be opened first for detail verification and freezing of technical requirements as per NIT. **No commercial aspect will be entertained in technical bid.**

3rd Part: COMMERCIAL

Only the successfully qualified technical bidders shall be considered for opening of commercial bid. The commercial bid shall be opened with prior intimation to the successful technically qualified bidders only. **The price should be quoted both in figures and words.**

9.0 SCOPE OF THE PROPOSAL

9.1 SCOPE OF THE TECHNICAL BID.

The scope of the proposal shall cover all/ the item(s) specified under the accompanying Technical Specification. It shall include the following:

- a) Detailed design of the item(s) as applicable.
- b) Guaranteed Technical Particulars to be furnished by the tenderer/bidder alongwith tender.
- c) Information to be furnished by the tenderer/bidder for appraisal of firm's capability & capacity to manufacture tendered item.



- d) Detail of Testing Facilities at manufacturer works as per requirement to tender.

9.2 SCOPE OF THE COMMERCIAL BID.

Bids containing deviations from provisions relating to the following clauses shall be considered as non-responsive:

- a) Price Basis
Clause 11.0 (Section-II)
- b) Contract Performance Guarantee:
Clause 7.0 (Section-I)
- c) Liquidated Damages:
Clause 13.0, General Condition of Contract (Section- III-GCC)
- d) Guarantee:
Clause 14.0, General Condition of Contract (Section- III-GCC)
- e) Payment:
Clause 27.0, General Condition of Contract (Section- III-GCC)

The determination of a Bid's responsiveness will be based on the contents of the Bid itself without recourse to extrinsic evidence.

- 9.3 Bids not **covering the above entire Scope of Work** shall be treated as incomplete and hence rejected.

10.0 BID PRICE.

10.1 The Bidder shall quote unit rates in the appropriate schedule of the Bid Form.

10.2 The Bidder shall also furnish the price breakup in the appropriate schedule for breakup of price in clause 13.5 of Section-II.

- i. Ex-works price of the equipment / materials (including tools and tackles etc.)
- ii. Charges for transportation and insurance i/e loading, unloading storages at site (FOT) for delivery of the equipments / materials up to their final destinations.
- iii. Excise duty, CST, Local Sale Tax/VAT, Octroi duty / entry tax, Service tax and any other levies legally payable on the transactions between the Owner and the Bidder.

11.0 PRICE BASIS

11.1 The bidders shall quote in their proposal price for the entire Scope of Supply covered under the Technical Specification as required in the Bid Proposal Sheets on price basis followed by Clause 13.0 of instruction to bidders.(SECTION-II)



11.2 Bidder shall indicate Bid prices in Indian Rupees only.

12.0 TAXES AND DUTIES

12.1 All custom duties, excise duties, sales taxes/VAT and other levies payable by the bidders in respect of the transactions between the bidder and their vendors/sub-suppliers while procuring any components, sub-assemblies, raw materials and equipment shall be included in the bid price and no claim on this behalf shall be entertained by TSECL. The bid price shall also be inclusive of excise duty and central sales tax and other levies in respect of the transactions solely between TSECL and the bidder under the Contract. **The local tax as applicable shall be clearly indicated which is reimbursable on production of document of actual payment.**

12.2 Concession of Sales Tax declaration forms, as admissible, shall be issued to the Contractor, on request, for all items (as identified in the price schedule of the Bid) to be supplied directly by the Contractor as well as for the items to be supplied by the Sub-suppliers as sale-in-transit.

12.3 Sales Tax on goods incorporated in the Supply:

The bidder shall include the Tripura Sales Tax/VAT or any other similar taxes under **the Sales Tax Act**, as applicable in their quoted bid price and TSECL shall not bear any liability on this account. **TSECL shall, however, deduct such taxes at source as per the rules and issue TDS Certificate to the Contractor.**

12.4 As regards the Income Tax Surcharge on Income Tax and other corporate taxes, the Bidder shall be responsible for such payment to the concerned authorities.

12.5 Service tax, as applicable on services rendered shall be responsibility of the bidder. TSECL shall not bear any liability on this account.

13.0 HOW TO QUOTE PRICE

13.1 Tenderer(s)/Bidder(s) shall quote FIRM rates based on raw materials.

13.2 Ex-works/ Go-down price(s) for any material should be same even if more than one rate is offered for the item. Slight variation to lower side may be there with higher production.

13.3 Chargeable Excise Duty as indicated above should remain same within the currency of delivery period unless statutory variation effected within that period.

13.4 In case Schedule delivery period is distributed in two financial years, chargeable Excise Duty shall be as that of lowest slab for supplies to be effected in the following Year.

13.5 **Ex-works rate & F.O.T. at Store yard at Deputy General Manager, Electrical Division No - III, Agartala, transportation & other charges (including unloading & stacking upto destination), should be furnished by the tenderer. Rate quoted will be presumed to indicate dispatch by Road Transport. Unless approved in extraordinary case, Transport by rail will not be accepted.**



SCHEDULE FOR BREAK UP OF RATE

a) Ex-Factory/ Go-down rate	Rs.		
b) Excise duty, E. Cess if applicable declare in % and amount, if not please clarify	Rs.		
c) C.S.T. applicable declare in % and amount.	Rs.		
<table border="1"><tr><td>Sub-total</td><td>Rs.</td></tr></table>		Sub-total	Rs.
Sub-total	Rs.		
d) Transportation & other charges (including unloading & stacking per unit upto destination)	Rs.		
<table border="1"><tr><td>TOTAL</td><td>Rs.</td></tr></table>		TOTAL	Rs.
TOTAL	Rs.		
e) TVAT if any other Taxes/ duties which is not mentioned above and Amount, if applicable	Rs.		
f) Validity period	-----days		
g) Earnest Money deposited in the shape of Demand Draft .	No.-----		
h) Sample Supplied -- Yes/No (If Yes,mention the quantity)	----- Nos.		
i) Discount if any	Percentage on Rs.-----		

- 13.6 Tender(s)/Bid(s) without indicating of aforesaid component shall be liable for rejection.
- 13.7 Any supplied materials if found not conforming to proper specification/ damaged/broken may be rejected and the same will have to be taken back by the supplier concerned at their own cost within 15 days, time from the date of receipt of intimation from the store yard of **Deputy General Manager, Electrical Division No - III, Agartala,**/ Consignee.
- 13.8 The supplier will be responsible for safe arrival of the materials in good condition for which the supplier will not be paid separately for transit insurance. Settlement of case with insurance will be the sole responsibility of the supplier. All breakages /damages/shortages will be at the account of the supplier.
- 13.9 Unloading of the materials at store yard of **Deputy General Manager, Electrical Division No - III, Agartala,**will be the responsibility of supplier or his authorized carrier representatives and the materials to be formally handed over to the concerned Manager/Sr. Manager in-charge of Store, otherwise ex-party decision on acceptability of materials will be taken by the **Deputy General Manager, Electrical Division No - III, Agartala,**, TSECL.



- 13.10 **The Bid offered will remain valid for 6 (Six) months from the Date of opening of the Pre-Qualification Bid.**
- 13.11 The supplier should be agreeable to supply full quantities of materials of the tendered Agreement Quantity within the agreement period.
- 13.12 The supplier should comply the delivery of materials as per schedule and maintain the quality of materials, otherwise performance in future shall be affected badly.
- 13.13 **Tenderer** should be careful in quoting rates. If the analysis rate of any materials done by TSECL appears to be un-workable the tenderer will have to furnish full details of the costing with cost of materials, labour charges, supervision, handling and transport etc., whenever called for otherwise, such unreasonable rates offered are liable for rejection.
- 13.14 All intimation to tenderer/supplier will be sent by Fax/Post/telegraph/ordinary letter/Registered post for which clear address has to be given by the tenderer. A letter issued to the tenderer/Supplier in any of the above form will be presumed that he has been informed of the matter and the Corporation will not be liable for postal delay/lapse.
- 13.15 In case the supplier fails to execute the order within the schedule of delivery for reason attributable to him and if the TSECL agrees to the extension of the delivery date, price rise if applicable within such extended period will not be entertained by the purchaser.
- 13.16 The Tender documents should invariably be submitted duly filled in all pages with signature of the tenderer.
- 13.17 **Tender(s) with documents, if offered, in violation of N.I.T. conditions will be liable for rejection.**

14.0 TIME SCHEDULE

- 14.1 The basic consideration and the essence of the Contract shall be strict adherence to the time schedule for performing the specified supply/works.
- 14.2 The requirement of completion schedule for the supply/works is mentioned in the accompanying Conditions of Contract.
- 14.3 The completion schedule as stated in the Conditions of Contract shall be one of the major factors in consideration of the Bids.
- 14.4 TSECL reserves the right to request for a change in the supply/ work schedule during post-bid discussion with successful bidder.

15.0 CONTRACT QUALITY ASSURANCE

- 15.1 The Bidder shall include in his proposal, the quality assurance programme containing the overall quality management and procedures which he proposed to follow in the performance of the supply/ works during various phases, as detailed in relevant clause of the General Technical Conditions.
- 15.2 At the time of award of Contract, the detailed quality assurance programme to be followed for the execution of the contract shall be mutually discussed and agreed to and such agreed programme shall form part of the contract.



16.0 INSURANCE

The bidder's insurance liabilities pertaining to the Scope of supply/Work are detailed out in clauses titled insurance in General Terms & Conditions of Contract. Bidder's attention is specifically invited to these clauses. The bid price shall include all the cost in pursuance of fulfilling all the insurance liabilities under the Contract.

17.0 BRAND NAMES

17.1 The specific reference in these specifications and documents to any material/equipment by brand name, make or catalogue number shall be construed as establishing standards of quality and performance and not as limiting competition. However, Bidders may offer other similar material/equipment provided they meet the specified standard, design and performance requirements. The Bidder shall furnish adequate technical information about such alternative material/equipment to enable TSECL to determine its acceptability. TSECL shall be the sole judge on the acceptability of such alternative material /equipment.

17.2 The Bidder shall note that standards for workmanship, material and equipment and reference to brand name or catalogue numbers designated by the Owner in its Technical Specification are intended to be descriptive only and not restrictive. The Bidder may substitute alternative standards, brand name and/or catalogue numbers in its Bid, provided that it demonstrates to the Owner's satisfaction that the substitutions are substantially equivalent or superior to those designed in the Technical Specification.

18.0 BID GUARANTEE

18.1 The Bidder shall furnish, as part of its Bid, **Earnest Money** for an amount as specified in the Notice Inviting Tender (NIT) in the shape of **Demand Draft** in favour of **TRIPURA STATE ELECTRICITY CORPORATION LIMITED** on any Nationalized / Schedule Bank, payable at Agartala, West Tripura.

18.2 The **Earnest Money** is required to protect TSECL against the risk of Bidder's conduct, which would warrant the earnest money forfeiture pursuant to Para 18.7.

18.3 The **Earnest Money** shall be deposited in Indian rupees only.

18.4 Any bid not secured in accordance with Para 18.1 and 18.3 above shall be rejected by TSECL as non-responsive.

18.5 The **Earnest Money** of the unsuccessful Bidders shall be discharged /returned as promptly as possible, but not later than 90 days after the expiration of the period of bid validity prescribed by the Owner.

18.6 The Earnest Money of the successful Bidder will be adjusted with the **Contract Performance Guarantee** required to be furnished on award of contract as per clause 7.0 of Section – I.

18.7 **The Earnest Money may be forfeited:**

- a) If a Bidder withdraws its bid during the period of bid validity specified by the Bidder on the bid form; or



- b) In case of a successful Bidder fails:
 - i. to sign the contract; or
 - ii. to furnish the **Contract Performance Guarantee**.

18.8 **No interest shall be payable by TSECL on the above earnest money.**

19.0 PERIOD OF VALIDITY OF BIDS

- 19.1 **Bids shall remain valid for 6 (six) calendar months after the date of bid opening prescribed by TSECL**, unless otherwise specified in the accompanying Special Conditions of Contract. A Bid valid for a shorter period shall be rejected by TSECL as non-responsive.
- 19.2 In exceptional circumstances, TSECL may solicit the Bidder's consent to an extension of the period of Bid validity. The request and response thereto shall be made in writing (including cable or fax). The **Earnest Money** provided under clause 4.0 of Section – I shall also be retained up to the extended period. No interest shall be payable by TSECL for retaining the **Earnest Money** up to the extended period. A Bidder may refuse the request without forfeiting the Earnest Money deposited by him. A Bidder granting the request shall not be required or permitted to modify his Bid.

SUBMISSION OF BIDS

20.0 FORMAT OF BID

- 20.1 The Bid shall be submitted in three parts as described in clause no. 5.1 of Section – I.
- 20.2 The Bid shall contain no interlineations, erasures or overwriting except as necessary to correct errors made by the Bidder, in which case such corrections shall be initialed by the person or persons signing the Bid.

21.0 SIGNATURE OF BIDS

- 21.1 The Bid must contain the name, residence and place of business of the person or persons making the Bid and shall be signed and sealed by the Bidder with his usual signature. The names of all persons signing shall also be typed or printed below the signature.
- 21.2 Bid by a partnership must be furnished with full names of all partners and be signed with the partnership name, followed by the signature(s) and designation(s) of the authorized partner(s) or other authorized representative(s).
- 21.3 Bids by Corporation / Company must be signed with the legal name of the Corporation/Company by the President, Managing Director or by the Secretary or other person or persons authorized to Bid on behalf of such Corporation / Company in the matter.



- 21.4 A Bid by a person who affixes to his signature the word 'President', 'Managing Director', 'Secretary', 'Agent', or other designation without disclosing his principal shall be rejected.
- 21.5 Satisfactory evidence of authority of the person signing on behalf of the Bidder shall be furnished with the Bid.
- 21.6 The Bidder's name stated on the proposal shall be exact legal name of the firm.
- 21.7 **Bids not conforming to all the above requirements of Para 21 above may be disqualified.**
- 21.8 **The original tender document shall be signed by the tenderer/ bidder on all pages and will be enclosed with the commercial bid.**
- 21.9 **The Bidder shall have to give a DECLARATION that he /they have gone through the details of the bidding document as per format appended herewith.**

22.0 SEALING AND MARKING OF BIDS

- 22.1 The three-part bid document shall be submitted followed by the Clause No.5.1 of **Section-I.** and the envelopes shall be addressed as follow.

**Additional General Manager (DP&C)
Tripura State Electricity Corporation Limited
Corporate Office, Bidyut Bhaban
Agartala, Tripura (West).
PIN: 799001
Ph: 0381 230 7433, Tele Fax: 0381 232 5345**

- 22.2 **The Earnest Money must be submitted in a separate sealed envelope with Pre-Qualification Bid.**

23.0 DEADLINE FOR SUBMISSION OF BIDS

- 23.1 The Bidders have the option of sending the Bid by registered post or submitting the Bid in person. Bids submitted by telex/telegram/fax shall not be accepted. No request from any Bidder to TSECL to collect the Bid from airlines, cargo agents etc. shall be entertained.
- 23.2 Bids shall be received by TSECL at the address specified under Para 22.1 of section - II, not later than the time & date mentioned in the Invitation to Bid.
- 23.3 TSECL may, at its discretion, extend this deadline for the submission of Bids, in which case all rights and obligations of TSECL and Bidders previously subject to the deadline shall thereafter be subject to the deadline as extended.

24.0 LATE BIDS



- 24.1 Any Bid received by TSECL after the time & date fixed or extended for submission of Bids prescribed by TSECL, shall be rejected and/or returned unopened to the Bidder.

25.0 MODIFICATION AND WITHDRAWAL OF BIDS

- 25.1 The Bidder may modify or withdraw its Bid after the Bid's submission provided that written notice of the modification or withdrawal is received by TSECL prior to the deadline prescribed for submission of Bids.
- 25.2 The Bidder's modification or withdrawal notice shall be prepared, sealed, marked and dispatched in accordance with the provisions of clause 22 of section – II.
- 25.3 No Bid shall be modified / withdrawn in the interval between the deadline for submission of Bids and the expiration of the period of Bid validity specified by the Bidder on the Bid Form. Withdrawal/modification of a Bid during this interval shall result forfeiture of the earnest money deposited by the bidder.

26.0 INFORMATION REQUIRED WITH THE PROPOSAL

- 26.1 The Bids must clearly indicate the name of the manufacturer, the type of model of each principal item of equipment proposed to be furnished and erected. The Bid shall also contain drawings and descriptive materials indicating general dimensions, principles of operation, the extent of pre-assembly involved, major construction equipment proposed to be deployed, method of erection and the proposed erection organizational structure.
- 26.2 The above information shall be provided by the Bidder in the form of separate sheets, drawings, catalogues, etc. in five copies
- 26.3 Any bid not containing sufficient descriptive material to describe accurately the equipment proposed, shall be treated as incomplete and hence rejected. Such descriptive materials and drawings submitted by the Bidder shall be retained by TSECL. Any major departure from these drawings and descriptive material submitted shall not be permitted during the execution of the Contract without specific written permission of TSECL.
- 26.4 Oral statements made by the Bidder at any time regarding quality, quantity or arrangement of the equipment or any other matter shall not be considered.
- 26.5 Standard catalogue pages and other documents of the Bidder may be used in the Bid to provide additional information and data as deemed necessary by the Bidder.
- 26.6 In case of the proposal information contradicts specification requirements; the specification requirements shall govern, unless otherwise brought out clearly in the technical / commercial deviation schedule.



BID OPENING AND EVALUATION

27.0 OPENING OF BIDS BY TSECL

27.1 First the cover containing **Earnest Money** as per clause **4.0 of Section - I** shall be opened and then documents of qualifying requirement as per clause 4.0 of Section-I shall be opened. Only those Bidders whose Bid contains Earnest Money and documents of Pre-Qualifying requirements as per the stipulations of clause 4.0 of Section - I shall be considered eligible for opening of Part – II(Technical Bid) of the Bid which shall also be opened on the same day, if possible. The **Price Bid** (Part – III) of the eligible bidders on the basis of evaluation of the Part-II Bid shall be opened on a subsequent date. The date of opening of the price Bid (Part-II) shall be notified in writing or by Fax to all qualified Bidders.

In case the above schedule date of opening of Bid is declared holiday by the State / Central Govt. the Bid will be opened on the following working day keeping time unaltered.

27.2 The Bid and its all parts shall be opened in the presence of Bidders' representatives (up to 2 persons) who choose to attend at the date and time for opening of bids indicated in the NIT or in case any extension has been given thereto, on the extended bid opening date and time notified to all the Bidders, who have purchased the Bidding Documents. The Bidders' representatives who are present shall sign a register evidencing their attendance.

No person / agent shall be allowed to present during of Bid without valid authorization from the concerned bidder.

27.3 The Bidders names, bid prices, modifications, bid withdrawals and the presence or absence of the requisite earnest money and such other details as TSECL, at its discretion, may consider appropriate shall be announced at the opening.

27.4 No electronic recording devices shall be permitted during bid opening.

28.0 CLARIFICATION OF BIDS

28.1 To assist in the examination, evaluation and comparison of Bids, TSECL may, at its discretion, ask the Bidder for a clarification of its Bid. The request for clarification and the response shall be in writing and no change in the price or substance of the Bid shall be sought, offered or permitted.

29.0 PRELIMINARY EXAMINATION

29.1 TSECL shall examine the Bids to determine whether they are complete, whether any computational errors have been made, whether required sureties have been furnished, whether the documents have been properly signed and whether the Bids are generally in order.

29.2 **Arithmetical errors shall be rectified on the following basis:**

If there is a discrepancy between the unit price and the total price that is obtained by multiplying the unit price and quantity, the unit price shall prevail and total price shall



be corrected. If there is a discrepancy between words and figures, the amount in words shall prevail. If the Bidder does not accept the correction of the errors as above, his bid shall be rejected and the amount of earnest money shall be forfeited.

The Bidder shall ensure that the prices furnished by him are complete. In the case of not quoting of rates of any item (supply) in the specified price schedules of the Bid Form, TSECL shall be entitled to consider the highest price of the tender for the purpose of evaluation and for the purpose of award of the Contract, use the lowest prices of the tender.

- 29.3 Prior to the detailed evaluation, TSECL shall determine the substantial responsiveness of each Bid w.r.t. Bidding Documents. For purpose of these Clauses, a substantially responsive Bid is one which conforms to all the terms and conditions of the Bidding Documents without material deviations. A material deviation is one which affects in any way the prices, quality, quantity or delivery period of the equipment or which limits in any way the responsibilities or liabilities of the Bidder or any right of TSECL as required in these specifications and documents. TSECL determination of a Bid's responsiveness shall be based on the contents of the Bid itself without recourse to extrinsic evidence.
- 29.4 A Bid determined as not substantially responsive shall be rejected by TSECL and may not subsequently be made responsive by the Bidder by correction of the non-conformity.
- 29.5 TSECL may waive any minor non-conformity or irregularity in a Bid which does not constitute a material deviation, provided such waiver does not prejudice or affect the relative ranking of any Bidder.

30.0 COMPARISON OF BIDS

- 30.1 **For comparison, individual bid price shall be considered as per Clause 13.0 of Section-II**
- 30.2 Evaluated bid prices of all the bidders shall be compared among themselves to determine the lowest evaluated Bid and, as a result of this comparison, the lowest Bid may be selected for award of the Contract.

31.0 CONTACTING THE OWNER

Bids shall be deemed to be under consideration immediately after they are opened and until such time official intimation of award/rejection is made by TSECL to the Bidders. While the bids are under consideration, Bidders and/or their representatives or other interested parties are advised to refrain from contacting by any means, the Owner and/or his employees/representatives on matters relating to the bids under consideration. TSECL, if necessary, shall obtain clarifications on the bids by requesting for such information from any or all the Bidders, either in writing or through personal contacts as may be necessary. Bidders shall not be permitted to change the substance of the bids after the bids have been opened.



AWARD OF CONTRACT

32.0 AWARD CRITERIA

32.1 TSECL shall award the Contract to the successful Bidder whose bid has been determined to be substantially responsive and has been determined as the lowest evaluated Bid, provided further that the Bidder is determined to be qualified to perform the Contract satisfactorily. TSECL shall be the sole judge in this regard.

32.2 Further, **TSECL reserves the right to award separate Contracts to two or more parties in line with the terms and conditions specified in the accompanying Technical Specifications.**

32.3 **On being Awarded with LOA (Letter of Award), the successful bidder should confirm the unconditional acceptance of LOA duly signature with stamp.**

33.0 OWNER'S RIGHT TO ACCEPT OR REJECT ANY BIDS OR ALL BIDS

33.1 TSECL reserves the right to accept or reject any bid, and to annul the bidding process and reject all bids at any time prior to award of contract, without thereby incurring any liability to the affected Bidder or Bidders or any obligation to inform the affected Bidder or Bidders of the grounds for such action.

34.0 NOTIFICATION OF AWARD

34.1 Prior to the expiration of the period of bid validity and extended validity period, if any, TSECL shall notify the successful Bidder in writing by registered letter or by cable or telex or FAX, to be confirmed in writing by registered letter, that his Bid has been accepted.

34.2 The Notification of Award/Letter of Award shall constitute the formation of the Contract.

34.3 Upon the successful Bidder's furnishing of **Contract Performance Guarantee** pursuant to Clause 7.0 of section – I. TSECL shall promptly notify each unsuccessful Bidder and will discharge its bid guarantee.

35.0 SIGNING OF CONTRACT

35.1 At the same time as TSECL notifies the successful Bidder that its bid has been accepted, TSECL shall send the Bidder the detailed Letter of Supply Order.

35.2 **Within 15 days of receipt of the detailed Letter of Supply Order, the successful Bidder shall attend the respective office of TSECL for signing the contract agreement.**

36.0 MEANING OF CONTRACT PERFORMANCE GUARANTEE

36.1 As a Contract Performance Security, the successful Bidder, to whom the work is awarded, shall be required to furnish a Contract Performance Guarantee in the shape of Demand Draft or Bank Guarantee on any Nationalized / Schedule Bank in favour of **Additional General Manager (DP&C) Tripura State Electricity Corporation**



Limited, Corporate Office, Bidyut Bhaban Agartala, Tripura (West). payable at Agartala, West Tripura. The guarantee amount shall be equal to **Ten Percent (10 %)** of the Contract Price and it shall guarantee the faithful performance of the Contract in accordance with the terms and conditions specified in these documents and specifications. The earnest money deposited at the time of tender shall be adjusted with the contract performance guarantee. The performance guarantee amount shall be deposited in accordance with the **Clause 7.0 of Section-I.**

- 36.2 The Performance Guarantee shall cover additionally the following guarantees to TSECL:
- a. The successful Bidder guarantees the successful and satisfactory operation of the materials/equipment supplied under the Contract, as per the specifications and documents.
 - b. The successful Bidder further guarantees that the material(s)/equipment supplied by him shall be free from all defects in design, material and workmanship and shall upon written notice from TSECL fully remedy free of expenses to TSECL such defects as developed under the normal use of the said materials/equipment within the period of guarantee specified in the relevant clause of the General Terms and conditions / Special Conditions of Contract.
- 36.3 The Contract Performance Guarantee is intended to secure the performance of the entire contract.
- 36.4 The Contract performance Guarantee amount shall be returned to the Contractor **without any interest** at the end of successful completion of the supply against a Bank Guarantee of equivalent amount from any Nationalized Bank valid up to the guarantee period.

37.0 CORRUPT OR FRAUDULENT PRACTICES

- 37.1 TSECL expects the bidders / suppliers / contractors observe the highest of ethics during the procurement and execution of such contracts. In pursuance of this policy, TSECL.
- a. Defines, for the purpose of this provision, the terms set forth below as follows;
 - i) “Corrupt practice” means offering, giving, receiving or soliciting of anything of value to influence the action of a official in the procurement process or in contract execution, and
 - (ii) “Fraudulent practice” means a misrepresentation of facts in order to influence a procurement process or the execution of a contract to the detriment of the owner, and includes collusive practice among bidders (prior to or after bid submission) designed to establish bid prices at artificial non-competitive levels and to deprive the owner from the benefits of free and open competition.



Will reject a proposal for award if it determines the bidder recommended for award has engaged a corrupt or fraudulent practice in competing for the contract in question.

Will declare a firm ineligible, either indefinitely or for a stated period of time, if owner any time determines that the firm has engaged corrupt / fraudulent practices in competing for, or in executing the contract.



SECTION-III

GENERAL TERMS & CONDITIONS OF CONTRACT

A. INTRODUCTION

1.0 DEFINITION OF TERMS

- 1.1 **'The Contract'** means the agreement entered into between Tripura State Electricity Corporation Limited and Contractor as per the Contract Agreement signed by the parties, including all attachments and appendices thereto and all documents incorporated by reference therein.
- 1.2 **'Contractor'** or **'Manufacturer'** shall mean the Bidder whose bid shall be accepted by TSECL for award of the Works and shall include such successful Bidder's legal representatives, successors and permitted assigns.
- 1.3 **'Sub-contractor'** shall mean the person named in the Contract for any part of the Works or any person to whom any part of the Contract has been sublet by the Contractor with the consent in writing of the Deputy General Manager-in-charge of the work and shall include the legal representatives, successors and permitted assigns of such person.
- 1.4 **'Consulting Engineer'/'Consultant'** shall mean any firm or person duly appointed as such from time to time by TSECL.
- 1.5 The terms **'Equipment'**, **'Stores'** and **'Materials'** shall mean and include equipment, stores and materials to be provided by the Contractor under the Contract.
- 1.6 **'Works'** shall mean and include the furnishing of equipment, labour and services, as per the Specifications and complete erection, testing and putting into satisfactory operation including all transportation, handling, unloading and storage at the Site as defined in the Contract.
- 1.7 **'Specifications'** shall mean the Specifications and Bidding Documents forming a part of the Contract and such other schedules and drawings as may be mutually agreed upon.
- 1.8 **'Site'** shall mean and include the land and other places on, into or through which the works and any adjacent land, paths, street or reservoir which may be allocated or used by TSECL or Contractor in the performance of the Contract.
- 1.9 The term **'Contract Price'** shall mean the item wise price / lump-sum price quoted by the Contractor in his bid with additions and/or deletions as may be agreed and incorporated in the Letter of Award, for the entire scope of the works.
- 1.10 The term **'Erection Portion'** of the Contract price shall mean the value of field activities of the works including erection, testing and putting into satisfactory operation including successful completion of performance and guarantee tests to be performed at Site by the Contractor including cost of insurances.
- 1.11 **'Manufacturer's Works'** or **'Contractor's Works'**, shall mean the place of work used by the manufacturer, the Contractor, their collaborators/associate or sub-contractors for the performance of the Contract.



- 1.12 **'Inspector'** shall mean TSECL or any person nominated by TSECL from time to time, to inspect the item(s) to be supplied/ equipment; stores or Works under the Contract and/or the duly authorized representative of TSECL.
- 1.13 **'Notification of Award of Contract'/'Letter of Award'/'Telex of Award'** shall mean the official notice issued by TSECL notifying the Contractor that his bid has been accepted.
- 1.14 **'Date of Contract'** shall mean the date on which Notification of Award of Contract/Letter of Award/Telex of Award has been issued.
- 1.15 **'Month'** shall mean the calendar month. **'Day or 'Days'**, unless herein otherwise expressly defined, shall mean calendar day or days of 24 hours each.
A **'Week'** shall mean continuous period of seven (7) days.
- 1.16 **'Writing'** shall include any manuscript, type written or printed statement, under or over signature and/or seal as the case may be.
- 1.17 When the words **'Approved'**, **'Subject to Approval'**, **'Satisfactory'**, **'Equal to'**, **'Proper'**, **'Requested'**, **'As Directed'**, **'Where Directed'**, **'When Directed'**, **'Determined by'**, **'Accepted'**, **'Permitted'**, or words and phrases of like importance are used, the approval, judgment, direction etc. is understood to be a function of TSECL.
- 1.18 **"Test on Completion"** shall mean such tests as prescribed in the Contract to be performed by the Contractor/Supplier(s) before the work is Taken Over by TSECL.
- 1.19 **'Start Up'** shall mean the time period required to bring the material(s)/ equipment covered under the Contract from an inactive condition, when construction is essentially complete, to the state ready for trial operation. The startup period shall include preliminary inspection and checkout of equipment and supporting sub-system, initial operation of the complete supplied item/equipment covered under the Contract to obtain necessary pre-trial operation data, perform calibration and corrective action, shut down, inspection and adjustment prior to the trial operation period.
- 1.20 **"Initial Operation"** shall mean the first integral operation of the complete equipment covered under the Contract with the sub-system and supporting equipment in service or available for service.
- 1.21 **'Trial Operation', 'Reliability Test', 'Trial Run', 'Completion Test'** shall mean the extended period of time after the start up period. During this trial operation period, the unit shall be operated over the full load range. The length of Trial Operation shall be as determined by the Engineer of TSECL unless otherwise specified elsewhere in the Contract.
- 1.22 **'Performance and Guarantee Test'** shall mean all operational checks and tests required to determine and demonstrate capacity, efficiency and operating characteristics as specified in the Contract Documents.
- 1.23 The term **'Final Acceptance/Taking Over'** shall mean acceptance of the Works performed under the Contract by TSECL, after successful completion of Performance and Guarantee Tests, as specified in the accompanying Technical Specification or otherwise agreed in the Contract.
- 1.24 **'Commercial Operation'** shall mean the Conditions of Operation in which the complete supply item(s)/ equipment covered under the Contract is officially declared by TSECL to be available for continuous operation at different loads up to and



- including rated capacity. Such declaration by TSECL, however, shall not relieve or prejudice the Contractor of any of his obligations under the Contract.
- 1.25 **'Guarantee period'/'Maintenance Period'** shall mean the period during which the Contractor shall remain liable for repair or replacement of any defective part(s) of the works/Supplies performed under the contract.
- 1.26 **'Latent Defects'** shall mean such defects caused by faulty designs, material or workmanship which cannot be detected during inspection, testing etc, based on the technology available for carrying out such tests.
- 1.27 **'Drawings', 'Plans'** shall mean all:
- a) Drawing furnished by TSECL as a basis for Bid Proposals.
 - b) Supplementary drawings furnished by TSECL to clarify and define in greater detail the intent of the Contract.
 - c) Drawings submitted by the Contractor with his Bid provided such drawings are acceptable to TSECL.
 - d) Drawings furnished by TSECL to the Contractor during the progress of the Supplies/Work; and
 - e) Engineering data and drawings submitted by the Contractor during the progress of the supplies/ Work provided such drawings are acceptable to the Deputy General Manager in charge of the work.
- 1.28 **'Codes'** shall mean the following including the latest amendments and / or replacement, if any:
- a) A.S.M.E. Test Codes.
 - b) A.I.E.E. Test Codes.
 - c) American Society of Testing Materials Codes.
 - d) Standards of the Indian Standards Institutions.
 - e) Other Internationally approved standards and / or Rules and Regulations touching the subject matter of the Contract.
- 1.29 Words imparting **'Person'** shall include firms, companies, corporation and association or bodies of individuals.
- 1.30 Terms and expressions not herein defined shall have the same meaning as are assigned to them in the Indian Sale of Goods Act (1930), failing that in the Indian Contract Act (1872) and failing that in the General Clauses Act (1897) including amendments thereof if any.
- 1.31 In addition to the above the following definitions shall also apply.
- a) **'All equipment and materials'** to be supplied shall also mean **'Goods'**.
 - b) **'Contract Performance Guarantee'** shall also mean **'Contract Performance Security'**
- 1.32 **General Climatic Conditions**



The equipment is required to operate satisfactory under the following site conditions:

- i) Max. temperature: 45 Degree C
- ii) Min. temperature: 3 Degree C
- iii) Max. relative humidity: 100%
- iv) Min. relative humidity: 26%
- v) Average No. of rainy days per annum (nearly): 120 days.
- vi) Average annual rainfall: 900 mm
- vii) Average No. of dust storm days per annum: 35
- viii) Isoceraunic level: 45
- ix) Max. wind pressure : 195 kg. per sq.m.
- x) Altitude above mean sea level Less than 1000 M

The area is in extreme climatic belt. Monsoons are generally active in the area from the month of April to September. The area is also prone to mild dust storms during the months of October to March. The maximum temperature in summer season shall be of the order of 45°C and minimum temperature in winters shall be of the order of 3°C. Normal day temperature during summer is 40°C.

2.0 APPLICATION

These General Conditions shall apply to the extent that they are not superseded by provisions in other parts of the Contract.

3.0 STANDARDS

The Goods supplied under this Contract shall conform to the standards mentioned in the Various Technical Specifications and when no applicable standard is mentioned; to the authoritative standard appropriate to the Goods and such standards shall be the latest issued by the concerned institution.

4.0 LANGUAGE AND MEASURES

All documents pertaining to the Contract including specification, Schedules, notices, correspondence, operating and maintenance instructions, drawings or any other writing shall be written in English language. The Metric System of measurement shall be used exclusively in the Contract.

5.0 CONTRACT DOCUMENTS

- 5.1 The term '**Contract Documents**' shall mean and include the following which shall be deemed to form an integral part of the Contract:



- a) Invitation of Bid including letter forwarding the Bidding Documents, Instructions to Bidders, General Terms and Conditions of Contract and all other documents included under the Special Conditions of Contract and various other sections.
- b) Specifications of the item(s)/material(s) to be furnished under the Contract as brought out in the accompanying Technical Specification.
- c) Contractor's Bid proposal and the documents attached there-to including the letter of clarifications thereto between the Contractor and TSECL prior to the Award of Contract.
- d) All the materials, literature, data and information of any sort given by the Contractor along with his bid, subject to the approval of TSECL.
- e) Letter of Award and any agreed variations of the conditions of the documents and special terms and conditions of contract if any.

6.0 USE THE CONTRACT DOCUMENTS AND INFORMATION

- 6.1 The Contractor/Bidder(s) shall not communicate or use in advertising, publicity, sales releases or in any other medium, photographs or other reproduction of the Works under this contract, or descriptions of the site, dimensions, quantity, quality, or other information, concerning the Works unless prior written permission has been obtained from TSECL.

7.0 MANNER OF EXECUTION OF CONTRACT

- 7.1 The contractor should attend the concerned office of TSECL within 15(fifteen) days from the date of issue of the Letter of Award to the Contractor for signing the contract agreement.
- 7.2 The Contractor shall provide for signing of the Contract, Performance Guarantee, appropriate power of attorney and other requisite materials.
- 7.3 The Agreement shall be signed in two originals and the Contractor shall be provided with one signed original and the rest shall be retained by TSECL.
- 7.4 The Contractor shall provide free of cost to TSECL all the engineering data, drawings, and descriptive materials submitted with the Bid, in at least six (6) copies to form a part of the contract immediately after issue of Letter of Award.
- 7.5 Subsequent to signing of the Contract, the Contractor, at his own cost, shall provide TSECL with at least five (5) true copies of Agreement within thirty (30) days after the signing of the Contract.

8.0 ENFORCEMENT OF TERMS

- 8.1 The failure of either party to enforce at any time any of the provisions of this Contract or any rights in respect thereto or to exercise any option therein provided, shall in no way be construed to be a waiver of such provisions, rights or options or in any way to affect the validity of the Contract. The exercise by either party of any of its rights



herein shall not prejudice either party from exercising the same or any other right it may have under the Contract.

9.0 COMPLETION OF CONTRACT

9.1 Unless otherwise terminated under the provisions of any other relevant clause, this Contract shall be deemed to have been completed on the date stipulated in the NIT.

B. GUARANTEE & LIABILITIES

10.0 TIME – THE ESSENCE OF CONTRACT

10.1 The time and the date of completion of the Contract as stipulated in the Contract by TSECL without or with modifications, if any, and so incorporated in the Letter of Award, shall be deemed to be the essence of the Contract. The Contractor shall so organize his resources and perform his Work as to complete it not later than the date agreed to.

The Contractor /Supplier(s) shall submit a detailed within the time frame agreed consisting of adequate number of activities covering various key phases of the Supply/Work such as design, procurement, manufacturing, activities within fifteen (15) days of the date of Notice of Award of Contract. This Bar Chart shall also indicate the interface facilities to be provided by TSECL and the dates by which such facilities are needed. The Contractor shall discuss with TSECL for finalization and approval of the Bar Chart by TSECL. The agreed Bar Chart shall form part of the contract documents. During the performance of the Contract, if in the opinion of the **Deputy General Manager, Electrical Division No - III, Agartala**, in charge of the work, proper progress is not maintained, suitable changes shall be made in the Contractor's operations to ensure proper progress without any cost implication to TSECL. The interface facilities to be provided by TSECL in accordance with the agreed Bar Chart shall also be reviewed while reviewing the progress of the Contractor.

Subsequent to the finalization of the Bar Chart, the Contractor shall make available to the in charge of the work. A detailed manufacturing programme in line with the agreed Contract Bar Chart. Such manufacturing programme shall be reviewed, updated and submitted to the **Deputy General Manager, Electrical Division No - III, Agartala**, in charge of the work once in every month thereafter.

10.2 The manufacturing programme shall be compatible with TSECL computer environment and furnished to TSECL on such media as may be desired by TSECL.

11.0 EFFECTIVENESS OF CONTRACT

11.1 The Contract shall be considered as having come into force from the date of the Notification of Award, unless otherwise provided in the Notification of Award.



12.0 EXTENSION OF TIME

- 12.1 The TSECL may consider to grant extension of time for the completion of the supply if it is felt absolutely essential on fulfillment of following conditions by the contractors:-
- a) The supplier/contractor must apply to the Engineer-in-charge in writing for extension of time in wiring so required justifying the necessity.
 - b) Such application must state the grounds which hindered the supply/contractor in the execution of the work within the time as stipulated in the contract document/agreement.
 - c) Such application must be made within 30 days of the date on which such hindrance had arisen.
 - d) The Engineer-in -charge must be of the opinion that the grounds shown for the extension of time are reasonable and without extension of such time completion of the work is practically impossible.
- 12.2 According to the terms of the contract the Engineer- in -charge has full powers, but the orders on the application of the supplier/ contractor connected with the agreement accepted by the authorities higher than the Engineer- in -charge should be issued by him only after written approval of the authorities higher than the Engineer-in-charge.
- 12.3 The opinion of the Engineer-in- charge, whether the grounds shown for the extension of time are or are not reasonable, is final. If the Engineer-in -charge is of the opinion that the Grounds shown by the supplier/ contractor are not reasonable and declines to the grant extension to time, the supplier/contractor cannot challenge.

13.0 LIQUIDATED DAMAGES

- 13.1 **In case the materials are not delivered within the time stipulated in the order, the supplier shall be liable to pay at the discretion of the competent authority of purchaser, the liquidated damages to be determined by the purchaser as 1 % of the delivered price of the delayed goods or un-performed services for each week of delay until actual delivery or performance subject to a maximum deduction of 10% of the delayed goods/services price. Due consideration may be given in the levy of damages for reasons absolutely beyond the control of the supplier for which documentary evidence shall be provided to the satisfaction of the competent delayed supplies.**

14.0 GUARANTEE

- 14.1 **The materials which are to be supplied, shall be guaranteed for a period of 18(Eighteen) month from the date of receipt of materials in stores or 12(twelve) months from the date of installation whichever is later**
- 14.2 The materials found defective within the above guarantee period shall be repaired / replaced by the supplier free of cost within three month of receipt of intimation. If the defective materials are not repaired/ replaced within the specified period, the



purchaser shall recover an equivalent amount plus 15 % supervision charges from any of his bills or from the performance guarantee deposit.

15.0 TAXES, PERMITS & LICENCES

15.1 The Contractor/Supplier(s) shall be liable and pay all non-Indian taxes, duties, levies lawfully assessed against TSECL or the Contractor in pursuance of the Contract. In addition, the Contractor shall be responsible for payment of all Indian duties, levies and taxes lawfully assessed against this contract.

16.0 ARBITRATION

16.1 All disputes or differences in respect of which the decision, if any, of the Engineer has not become final or binding as aforesaid shall be settled by arbitration in the manner hereinafter provided.

16.2 The arbitration shall be conducted by three arbitrators, one each to be nominated by the Contractor and the Owner and the third to be appointed as an umpire by both the arbitrators in accordance with the Indian Arbitration Act. If either of the parties fails to appoint its arbitrator within sixty (60) days after receipt of a notice from the other party invoking the Arbitration clause, the arbitrator appointed by the party invoking the arbitration clause shall become the sole arbitrator to conduct the arbitration.

16.3 The arbitration shall be conducted in accordance with the provisions of the Indian Arbitration & Reconciliation Act, 1996 or any statutory modification thereof. The place & venue of arbitration shall be AGARTALA.

16.4 The decision of the majority of the arbitrators shall be final and binding upon the parties. The arbitrators may, from time to time with the consent of all the parties enlarge the time for making the award. In the event of any of the aforesaid arbitrators dying, neglecting, resigning or being unable to act for any reason, it will be lawful for the party concerned to nominate another arbitrator in place of the outgoing arbitrator.

16.5 The arbitrator shall have full powers to review and/or revise any, decision, opinion, direction, certification or valuation of the Engineer in accordance with the Contract, and neither party shall be limited in the proceedings before such arbitrators to the condense or arguments out before the Engineer for the purpose of obtaining the said decision.

16.6 No decision given by the Engineer in accordance with the foregoing provisions shall disqualify him as being called as a witness or giving evidence before the arbitrators on any matter whatsoever relevant to the dispute or difference referred to the arbitrators as aforesaid.

16.7 During settlement of disputes and arbitration proceedings, both parties shall be obliged to carry out their respective obligations under the Contract.

17.0 LEGAL JURISDICTION

17.1 Any dispute or difference arising under/out of or in connection with this tender or contract shall be subject to exclusive jurisdiction of the local High Court.



18.0 DEDUCTION

18.1 Any amount which becomes payable by the supplier under particular contract shall be deducted by the purchaser from any amount that is due or becoming due under the same or any other contract and shall be adjusted.

19.0 LIMITATION OF LIABILITIES

19.1 The final payment by TSECL in pursuance of the Contract shall mean the release of the Contractor from all his liabilities under the Contract. Such final payment shall be made only at the end of the Guarantee/Warranty Period, and till such time as the contractual liabilities and responsibilities of the Contractor, shall prevail. All other payments made under the Contract shall be treated as on-account payments.

20.0 PRE-DISPATCH INSPECTION

20.1 Dispatch of material is subjected to pre-dispatch inspection/testing by the purchaser's representative/engineers and clearance thereof. All acceptance tests and inspection shall be carried out at the place of manufacture unless otherwise specially agreed upon by the purchaser and the supplier at the time of purchase.

In case of waiver of inspection, the consignee will be at liberty for testing of material in the laboratories of Tripura or outside for acceptance if required, at the cost of the supplier.

20.2 The manufacturer shall offer to the inspectors representing the purchaser all the reasonable testing facilities free of charge for inspection and testing to satisfy that material being supplied is in accordance with the specifications.

20.3 The purchaser's representative/engineer attending above testing will carry out testing of suitable number of items as per the sampling procedure laid down in the corresponding IS as the case may be and issue test certificate approval to the manufacturer and give clearance for dispatch.

20.4 **All expenses involved due to lodging & boarding to stay outside the State (TRIPURA) for conducting pre-dispatch acceptance test including fare for To & Fro journeys, shall have to be borne by the supplier.**

20.5 **Mode of Transport from Agartala, (Tripura) to destination place of manufactures works, shall be by Air. In case where Air transport is un-available, for journeys on-wards Kolkata, Rail transport of A.C. Two Tiers shall be arranged.**

20.6 **Number of inspecting engineer(s) may vary to a maximum strength of 3(Three) and shall be determined by the TSECL depending on quantity and methodology of testing.**

21.0 INSPECTION AFTER RECEIPT OF STORES

21.1 The purchaser shall have option to test the samples selected at random from the supply affected to ensure that the supplies conform in quality and workmanship to the relevant specifications and also conform to the approved sample.



- 21.2 Fifteen days advance intimation will be given to the suppliers to depute representative to witness the tests and if the materials failed, the testing will be carried out in absence of their representative on the schedule date. If the materials fail, in above random sample testing, the lot will be rejected.
- 21.3 No testing charges would be recovered for the first testing. In case the repaired/replaced supplied item fail again on testing, the charges for testing together with all incidental expenses incurred by the purchaser shall be borne by the suppliers.
- 21.4 The materials supplied against the order and not conforming to the specifications shall have to be collected by the supplier at his cost, on refunding the amounts paid therefore, within 7 days of intimation of failure of these meters on testing.

22.0 CHANGE OF QUANTITY

- 22.1 During the execution of the Contract, TSECL reserves the right to increase or decrease the quantities of items under the Contract but without any change in unit price or other terms & conditions. Such variations unless otherwise specified in the **accompanying Special Conditions of Contract and/or Technical Specification**, shall not be subjected to any limitation for the individual items but the total variations in all such items under the Contract shall be limited to a percentage of the Contract price as specified in the **Special Conditions of Contract**.
- 22.2 The Contract price shall accordingly be adjusted based on the unit rates available in the Contract for the change in quantities as above. The base unit rates, as identified in the Contract shall however remain constant during the currency of the Contract, except as provided for in clause 27.0 below. In case, the unit rates are not available for the change in quantity, the same shall be subjected to mutual agreement.

23.0 PAKCING, FORWARDING AND SHIPMENT

- 23.1 The Supplier/ Contractor shall pack and crate all equipment in such a manner as to protect them from deterioration and damage during rail and road transportation to the site and storage at the site till the time of erection. The Contractor shall be held responsible for all damages due to improper package.

The Supplier/Contractor shall notify the **Deputy General Manager, Electrical Division No - III, Agartala**, under the AGM, Electrical Circle No-II, Agartala: in charge of the work of the date of each shipment from his works, and the expected date of arrival at the site.

- 23.2 The Supplier/Contractor shall also give all shipping information concerning the weight, size and content of each packing including any other information the **Deputy General Manager, Electrical Division No - III, Agartala**, in charge of the work may require.
- 23.3 The Supplier/Contractor shall prepare detailed packing list of all packages and containers, bundles and loose materials forming each and every consignment dispatch to Site. The Supplier/Contractor shall further be responsible for making all necessary arrangements for loading, unloading and other handling of the materials, right from his works up to the Site.



24.0 NO WAIVER RIGHTS OF AGREEMENT/CONTRACT PROVISION

24.1 Neither the inspection by TSECL nor any order by TSECL for payment of money or any payment for or acceptance of, the whole or any part of the supply by the DGM in charge of the supply, nor any possession taken by the DGM in charge of the supply shall operate as a waiver of any provision of the Contract, or of any power herein reserved to TSECL or any right to damages herein provided nor shall any waiver of any breach in the Contract be held to be a waiver of any other or subsequent breach.

25.0 CERTIFICATE NOT TO AFFECT RIGHT OF TSECL AND LIABILITY OF CONTRACTOR.

25.1 No interim payment certificate of the **Deputy General Manager, Electrical Division No - III, Agartala**, in charge of the work, nor any sum paid on account by TSECL, nor any extension of time for execution of the Works granted by TSECL shall affect or prejudice the rights of TSECL against the Contractor or relieve the Contractor of his obligation for the due performance of the Contractor, or be interpreted as approval of the Works done or of the equipment furnished and no certificate shall create liability for TSECL to pay for alterations, amendments, variations or additional works not ordered, in writing, by the **Deputy General Manager, Electrical Division No - III, Agartala**, in charge of the work or discharge the liability of the Contractor for the payment of damages whether due, ascertained or certified or not or any sum against the payment of which he is bound to indemnify TSECL, nor shall any such certificate nor the acceptance by him of any sum paid on account or otherwise affect or prejudice the rights of TSECL against the Contractor.

CONTRACT SECURITY AND PAYMENTS

26.0 CONTRACT PERFORMANCE GUARANTEE

26.1 The Supplier/Contractor shall furnish contract performance guarantee as specified in clause 7.0 of Section - I for the proper fulfillment of the Contract in the shape of demand draft in favour of Tripura State Electricity Corporation Limited payable at Agartala, West Tripura within fifteen (15) days of "Notice of Award of Contract."

26.2 CONTRACT PRICE ADJUSTMENT

"All prices / price components of the contract shall remain firm and no adjustment of price, whatsoever, shall be applicable during the currency of contract"

27.0 PAYMENT

27.1 The payment to the Supplier/Contractor for the performance of the Supply/Works under the Contract will be made by TSECL as per the guidelines and conditions specified herein. All payment made during the Contract shall be on account payee cheque only. In the event of payment through demand draft, bank charge if any shall be at contractor account. The final payment will be made on completion of all Supply/Works and on completion of warranty / guaranty period including fulfillment by the Contractor of all his liabilities under the Contract.



27.2 **Currency of Payment**

All payments under the Contract shall be in Indian Rupees only.

28.0 **Due Dates for Payments**

28.1 TSECL will make progressive payment as and when the payment is due as per the terms of payment

29.0 **Mode of Payment**

29.1 Payment due on supply materials / services shall be made by the DGM in charge for execution of the agreement through account payee cheque.

30.0 **Terms of Payment**

- a) Payment will be made on receipt of materials in good condition by the consignee.
- b) For tenderer(s)/supplier(s) outside the State of Tripura cheque will be drawn on S.B.I or other Schedule Bank, payable at the place where the supply order is placed.
- c) For tenderer within the State of Tripura cheque will be drawn on S.B.I, T.L.A Branch or other Schedule Bank, Agartala.
- d) Any terms of advance payments i.e. payments against dispatch documents/Bank documents will not be acceptable.
- e) **In no circumstances, claim of interest on payment shall be entertained.**

31.0 **INSURANCE**

31.1 The Contractor at his cost shall arrange, secure and maintain all insurance as may be pertinent to the Works and obligatory in terms of law to protect his interest and interests of the Owner against all perils detailed herein. The form and the limit of such insurance as defined herein together with the under-writer in each case shall be acceptable to the Owner. However, irrespective of such acceptance, the responsibility to maintain adequate insurance coverage at all times during the period of Contract shall be of the Contractor alone. The Contractor's failure in this regard shall not relieve him of any of his contractual responsibilities and obligations. The insurance covers to be taken by the Contractor shall be in a joint name of the Owner and the Contractor. The Contractor shall, however, be authorized to deal directly with Insurance Company or Companies and shall be responsible in regard to maintenance of all insurance covers. Further the insurance should be in freely convertible currency.

31.2 Any loss or damage to the goods during handling, transportation and storage shall be to the account of the Contractor. The Contractor shall be responsible for preference of all claims and make good the damages or loss by way of repairs and/or replacement of the equipment, damaged or lost. The transfer of title shall not in any way relieve the Contractor of the above responsibilities during the period of Contract. The Contractor shall provide the Owner with copy of all insurance policies and documents taken out by him in pursuance of the Contract. Such copies of documents shall be submitted to



the Owner immediately after such insurance coverage. The Contractor shall also inform the Owner in writing at least sixty (60) Days in advance regarding the expiry/cancellation and/or change in any of such documents and ensure revalidation, renewal etc., as may be necessary well in time.

- 31.3 The perils required to be covered under the insurance shall include, but not be limited to fire and allied risks, miscellaneous accidents, workman compensation risks, loss or damage in transit, theft, pilferage riot and strikes and malicious damages, civil commotion, weather conditions, accidents of all kinds, etc. The scope of such insurance shall be adequate to cover the replacement/reinstatement cost of the equipment for all risks up to and including delivery of goods and other costs till the equipment is delivered at Site. The insurance policies to be taken should be on replacement value basis and/or incorporating escalation clause. Notwithstanding the extent of insurance cover and the amount of claim available from the underwriters, the Contractor shall be liable to make good the full replacement/rectification value of all equipment/materials and to ensure their availability as per project requirements.
- 31.4 All costs on account of insurance liabilities covered under the Contract will be to Contractor's account and will be included in Contract Price, However, the Owner may from time to time, during the pendency of the Contract, ask the Contractor in writing to limit the insurance coverage, risks and in such a case, the parties to the Contract will agree for a mutual settlement, for reduction in Contract price to the extent of reduced premium amount. The Contractor, while arranging the insurance shall ensure to obtain all discounts on premium, which may be available for higher volume or for reason of financing arrangement of the project.
- 31.5 The clause entitled 'Insurance' under the Section ECC, covers the additional insurance requirements for the portion of the works to be performed at the Site.

32.0 LIABILITY FOR ACCIDENTS AND DAMAGES

- 32.1 Under the Contract, the Contractor shall be responsible for loss or damage to the equipment until the successful completion of commissioning as defined else-where in the Bidding Documents.

33.0 DEMURRAGE, WHARFAGE, ETC.

- 33.1 All demurrage, wharf age and other expenses incurred due to delayed clearance of the material or any other reason shall be to the account of the Contractor.

34.0 FORCE MAJEURE

- 34.1 Force majeure is herein defined as any cause which is beyond the control of the Contractor or the Owner as the case may be, which they could not foresee or with a reasonable amount of diligence could not have foreseen and which substantially affects the performance of the Contract, such as:
- a. Natural phenomena, including but not limited to floods, droughts, earthquakes and epidemics;
 - b. Acts of any Government, domestic or foreign, including but not limited to war, declared or undeclared, priorities, quarantines, embargoes. Provided either party



shall within fifteen (15) days from the occurrence of such a cause notify the other in writing of such causes.

- 34.2 The Purchaser or the Owner shall not be liable for delays in performing his obligations resulting from any force-majeure cause as referred to and/or defined above.

The date of completion will, subject to hereinafter provided, be extended by a reasonable time even though such cause may occur after Contractor's performance of obligation has been delayed due to other causes.

35.0 CONTRACTOR'S DEFAULT:

- 35.1 The Contractor shall have to pay liquidated damages for delay in completion of Works as defined in clause 13.0 of this Section.

The termination of the Contract under this clause shall neither entitle the Contractor to reduce the value of the Contract Performance Guarantee nor the time thereof. The Contract Performance Guarantee shall be valid for the full value and for the full period of the Contract including guarantee period.

36.0 TERMINATION OF CONTRACT ON OWNER'S INITIATIVE

- 36.1 The Owner reserves the right to terminate the Contract either in part or in full due to reasons other than those mentioned under clause entitled "Contractor's Default." The Owner shall in such an event give fifteen (15) days notice in writing to the Contractor of his decision to do so.

- 36.2 The Contractor upon receipt of such notice shall discontinue the work on the date and to the extent specified in the notice, make all reasonable efforts to obtain cancellation of all orders and contracts to the extent they are related to the work terminated and terms satisfactory to the Owner, stop all further sub-contracting or purchasing activity related to the work terminated, and assist the Owner in maintenance, protection, and disposition of the Works acquired under the Contract by the Owner.

- 36.3 In the event of such a termination, the Contractor shall be paid compensation, equitable and reasonable, dictated by the circumstances prevalent at the time of termination.

- 36.4 If the Contractor is an individual or a proprietary concern and the individual or the proprietor dies and if the Contractor is a partnership concern and one of the partners dies then unless the Owner is satisfied that the legal representatives of the individual contractor or of the proprietor of propriety concern and in the case of partnership, the surviving partners, are capable of carrying out and completing the Contract, the Owner shall be entitled to cancel the Contract as to its uncompleted part without being in any way liable to payment of any compensation to the estate of deceased Contractor and/or to the surviving partners of the Contractor's firm on account of the cancellation of the Contract. The decision of the Owner that the legal representatives of the deceased Contractor or surviving partners of the Contractor's firm cannot carry out and complete the Contract shall be final and binding on the parties. In the event of such cancellation, the Owner shall not hold the estate of the deceased Contractor and /



or the surviving partner of the Contractor's firm liable to damages for not completing the Contract.

37.0 GRAFTS AND COMMISSIONS ETC.

37.1 Any graft, commission, gift or advantage given, promised or offered by or on behalf of the Contractor or his partner, agent, officers, director, employee or servant or any one on his or their behalf in relation to the obtaining or to the execution of this or any other Contract with the Owner, shall in addition to any criminal liability which it may incur, subject the Contractor to the cancellation of this and all other contracts and also to payment of any loss or damage to the Owner resulting from any cancellation. The Owner shall then be entitled to deduct the amount so payable from any monies otherwise due to Contractor under the Contract.

38.0 SETTLEMENT OF DISPUTES:

38.1 Any dispute(s) or difference (s) arising out of or in connection with the Contract shall, to the extent possible, be settled amicably between the parties.

38.2 If any dispute or difference of any kind whatsoever shall arise between the Owner and the Contractor, arising out of the Contract for the performance of the Works whether during the progress of the Works or after its completion or whether before or after the termination, abandonment or breach of the Contract, it shall, in the first place, be referred to and settled by the Engineer, who, within a period of thirty (30) days after being requested by either party to do so, shall give written notice of his decision to the Owner and the Contractor.

38.3 Save as hereinafter provided, such decision in respect of every matters so referred shall be final and binding upon the parties until the completion of the Works and shall forthwith be given effect to by the Contractor who shall proceed with the Works with all due diligence, whether he or the Owner requires arbitration as hereinafter provided or not.

38.4 If after the Engineer has given written notice of his decision to the parties, no claim to arbitration has been communicated to him by either party within thirty (30) days from the receipt of such notice, the said decision shall become final and binding on the parties.

38.5 In the event of the Engineer failing to notify his decision as aforesaid within thirty (30) days after being requested as aforesaid, or in the event of either the Owner or the Contractor being dissatisfied with any such decision, or within thirty (30) days, after the expiry of the first mentioned period of thirty (30) days, as the case may be, either party may require that the matters in dispute be referred to arbitration as hereinafter provided.

39.0 REGULATION OF LOCAL AUTHORITIES

39.1 The Contractor shall comply with all the rules and regulations of local authorities during the performance of his execution activities. He shall also comply with the Minimum Wages Act, 1948 and the Payment of Wages Act (both of the Government of India) and the rules made there-under in respect of any employee or workman employed or engaged by him or his Sub-Contractor.



39.2 All registration and statutory inspection fees, if any, in respect of his work pursuant to this Contract shall be to the account of the Contractor. However, any registration, statutory inspection fees lawfully payable under any statutory laws and its amendments from time to time during installation & commissioning in respect of the equipment ultimately to be owned by the Owner, shall be to the account of TSECL. Should any such inspection or registration need to be re-arranged due to the fault of the Contractor or his Sub-Contractor, the additional fees to such inspection and/or registration shall be borne by the Contractor.

40.0 OWNER'S LIEN ON EQUIPMENT

40.1 TSECL shall have a lien on all equipment including those of the Contractor brought to the Site for the purpose of installation, testing and commissioning of the equipment, machine(s), other Hardware to be supplied & installed under the Contract. TSECL shall continue to hold the lien on all such equipment throughout the period of Contract. No material brought to the Site shall be removed from the Site by the Contractor and/or his Sub-Contractors without the prior written approval of the Engineer.

41.0 Safety Rules:

- 41.1 a) Each employee shall be provided with initial indoctrination regarding safety by the Contractor, so as to enable him to conduct his work in a safe manner.
- b) No employee shall be given a new assignment of work unfamiliar to him without proper introduction as to the hazards incident thereto, both to himself and his fellow employees.
- c) Under no circumstances shall an employee hurry or take unnecessary chance when working under hazardous conditions.
- d) Employees under the influence of any intoxicating beverage, even to the slightest degree shall not be permitted to remain at work.
- e) There shall be a suitable arrangement at every work site for rendering prompt and sufficient first aid to the injured.
- 41.2 The Contractor shall follow and comply with all relevant Safety Rules, relevant provisions of applicable laws pertaining to the safety of workmen, employees, plant and equipment as may be prescribed from time to time without any demur, protest or contest or reservation. In case of any discrepancy between statutory requirement and relevant Safety Rules referred above, the later shall be binding on the Contractor unless the statutory provisions are more stringent.
- 41.3 If the Contractor does not take all safety precautions and/or fails to comply with the Safety Rules as prescribed by Consortium or under the applicable law for the safety of the equipment and plant and for the safety of personnel and the Contractor does not prevent hazardous conditions which cause injury to his own employees or employees of other contractors, or Employees of TSECL or any other person who are at Site or adjacent thereto, the Contractors shall be responsible for payment of compensation to Consortium members as per the compensation order issued by the appropriate authority of Government of Tripura / verdict issued by court. The compensation



mentioned above shall be in addition to the compensation payable to the workmen / employees under the relevant provisions of the Workmen's Compensation Act and rules framed there under or any other applicable laws as applicable from time to time. In case TSECL is made to pay such compensation then the amount of such compensation shall be deducted from the progressive bills / contract performance guaranty of the contractor.

++++



SECTION – IV

TECHNICAL SPECIFICATION FOR 11M AND 9M LONG STEEL TUBULAR POLE

1.0 SCOPE

This specification covers the design, manufacture, testing at works, supply / delivery & transportation of 11mtr and 9mtr long Steel tubular Pole conforming to IS: 2713 (P-I & II)/1980 and as amended latest with cast iron base plate.

2.0 STANDARDS

The 11mtr and 9mtr long Steel tubular Pole shall conform in all respect to the relevant Indian/ International Standard Specification, with latest amendments.

SPECIFICATION FOR 11MTR AND 9MTR LONG STEEL TUBULAR POLES AS PER ISS:2713 (P-I & II)/1980 AND AS AMENDED LATEST.

1. Type of Poles:- 11mtr and 9mtr long Steel tubular Pole of swaged and welded type.
2. Designation of Pole :-
 - i) 11mter = 410:SP-54
 - ii) 9mter = 410:SP-32
3. Outside Diameter of Sections :-

Items	410:SP-32	410:SP-54
Top(mm)	114.3	114.3
Middle(mm)	139.7	139.7
Bottom(mm)	165.1	165.1

4. Thickness of Sections :-

Items	410:SP-32	410:SP-54
Top(mm)	3.65	3.65
Middle(mm)	4.50	4.50
Bottom(mm)	4.85	5.40

5. Tolerances:-

- i) Outside Diameter:- The outside diameters of the poles shall not vary from the appropriate value, except at the joint, by more than ± 1.0 percent.
- ii) Thickness :-Thickness shall not fall below the thickness specified by more than 10 percent.
- iii) Length :- The tolerance on the length shall be as follows:
On the length of any section ± 40 mm.
On the overall length of pole ± 25 mm.



- iv) Weight :- Mean weight for bulk supplies shall be not more than 7.5 percent below the calculated value. The weight of any single pole shall not fall below the calculated weight by more than 10 percent.
- v) Straightness :- The finished pole shall not be out of straightness by more than 1/600 of its length.
6. Protection against corrosion:-
The poles shall be coated with black bituminous paint (conforming to IS:158/1968) of two coats throughout, internally and externally, up to the level which goes inside the earth including 1m above the earth level. The working portion of the exterior shall be painted with two coat of red oxide primer (conforming to IS:2074/1979).
7. Earthing arrangements:-
Poles shall be provided with earthing arrangement with a thorough hole of 14 mm dia. which shall be provided at a height of 300mm above the planting depth.
8. M.S. Base Plate:-
M.S. base plate as per drawing shall have to be welded to bottom portion of the pole. Both planes of the plate to be welded along the circumference of the bottom portion of the pole.
Two coats of bituminous paint (conforming to IS: 158/1968) shall be **provided on all surface of the M.S. Plate.**
9. Top cap :-
Canopy shaped plate of thickness same as that of top section of the pole shall be provided at the top of the pole with proper welding.
10. The poles shall be made of welded tube of suitable length (indicated in the relevant IS and enclosed drawing) swaged together and conforming to chemical composition and physical requirement of the specification. The material to be used for the poles shall be of minimum tensile strength of 42 kgt per Sqmm.
11. Chemical Composition:- As per IS:228(P-III)/1972 and IS:228(P-IX)/1975 or as amended latest.
12. Minimum Tensile Strength :- 42Kgf/mm² (For all sizes of steel Tubular Poles)
13. Approx. Weight of each pole :- i) 9 mtr. = 154 Kg.
ii) 11 mtr = 194 Kg
14. Breaking load of each pole (in N/kgf) i) 9 mtr. = 5430/554
ii) 11 mtr = 5030/513
15. Crippling load of each pole (in N/kgf) i) 9 mtr. = 3850/393



ii) 11 mtr =3570/364

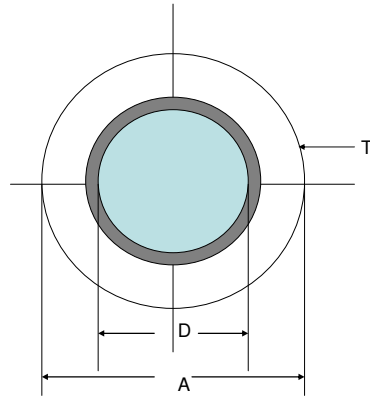

Details of Base Plate

Bottom Dia of plate Pole (D)	Thickness (T)	Outer Dia. of base (A)
165.1mm	8mm	400mm

Fig- 1 Mild Steel Base Plate

All Dimensions are in

mm

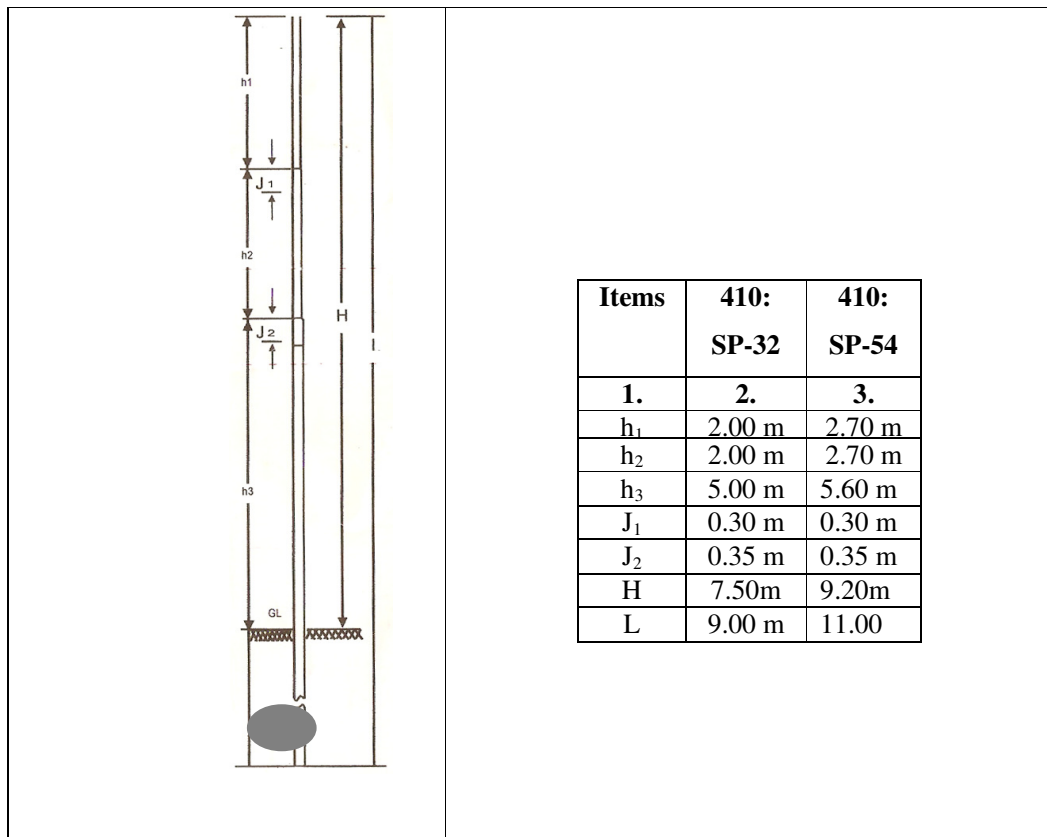

Fig- 2 Steel Pole



3.0 SERVICE CONDITIONS

The 11mtr and 9mtr long Steel tubular Pole to be supplied against this section shall be suitable for satisfactory continuous operation under the flowing climatic conditions as per ISS:2713(P-I & II)/1980 and as amended latest.

i. Location :	At various locations in Tripura.
ii. Max. ambient air temperature (Deg° C):	45
iii. Min. ambient air temperature (Deg° C):	4
iv. Max. yearly daily ambient air temperature (Deg° C):	40
v. Max average weighed average ambient temperature (Deg° C):	32
vi. Max. Altitude above mean sea level(meters):	1000 m.

4.0 TEST AND INSPECTION

4.1 Following tests shall be carried out at the works of the manufacturer as per relevant ISS before delivery of each lot in presence of the representative of purchaser:

A. Acceptance Tests:

- Deflection test,
- Permanent set test, and
- Drop test.
- Physical verification of dimensions.

B. Routine Tests:

- Deflection test
- Permanent set test, and
- Drop test.
- Physical verification of dimensions.

C. Type Tests:

Type test shall be carried out as per IS:2713(Part I)/1980 and as amended latest number of poles selected for conducting the above test shall be as follows:

Lot size	No. of poles
Up to 500	5
501 to 1000	8
1001 to 2000	13
2001 to 3000	18
3001 and above	20

Sample at random will be selected from the offered lot for the above testing and the lot will be accepted subject to permissible limit of failure as per IS.



Note: - Purchaser reserves the right to get all or any test carried out on one sample per 20 nos. of Steel Tubular Poles at the cost of supplier from any recognized laboratory / government test house.

4.2 The supplier shall furnish the type test / the routine test certificate as part of the condition for supply of 11mtr and 9mtr long Steel tubular Pole in bulk quantity at the discretion of the purchaser.

4.3.0 INSPECTION

4.3.1 All test and inspection shall be made at the place of manufacture unless otherwise especially agreed upon by the manufacturer and purchaser at the time of purchase. The manufacturer shall afford the inspector representing the purchaser all reasonable facilities without charge to satisfy him that the material is being furnished in accordance with specification.

4.3.2 The purchaser reserves the right to have the test carried at the cost of the supplier by an independent agency whenever there is dispute regarding the quality of supply.

5.0 PACKING & MARKING

5.1 PACKING

Poles shall be well finished, clean and free from harmful surface defects.

The steel Tubular Poles shall be so transported that the poles are adequately protected against damage in ordinary handling and transit. To avoid damage of the Steel Poles, transshipment in between the road transportation must be avoided i.e. each consignment should be transported from factory to store yard at **DGM, Electrical Division-IV, Udaipur** through a single carrier.

5.2 MARKING

Each pole shall bear the following permanent marking on a place just at the beginning of the middle section of the pole from bottom along the axis of the pole:

- a). Manufacturer's Name
- b). Manufacturer's Trade mark
- c). Designation of the pole
- d). "TSECL"
- e). Year of manufacture
- f). ISI certification mark if any.

6.0 GUARANTEED TECHNICAL PARTICULARS

The guaranteed technical particulars of 11mtr and 9mtr long Steel Tubular Pole offered shall be given by the bidder along with the tender.



Guaranteed & other technical particulars for 11m and 9m Steel Tubular Poles

(To be furnished by the Manufacturer)

Sl.No.	Item	Description	
		11mtr	9mtr
1.	Make & Manufacturer		
2.	Place of Manufacture		
3.	Type of Poles		
4.	Designation of Pole		
5.	Outside Diameter of sections:- 1) Top (mm) ii) Middle (mm) ii) Bottom (mm)		
6.	Thickness of sections i) Top (mm) ii) Middle (mm) iii) Bottom (mm)		
7.	Tolerance i) Outside Diameter ii) Thickness ii) Length iv) Weight v) Straightness		
8.	Protection against corrosion:-		
9.	Earthing arrangements :-		
10.	M.S.Base Plate :-		
11.	Top cap :-		
12.	Minimum Tensile Strength		
13.	Chemical Composition		
14.	Approx .Weight of each pole		
15.	Breaking load of each pole		
16.	Crippling load of each pole		
17.	Marking as per clause No.5.2 of section-IV		

Signature of Authorised
Signatory of the firm.



**OLLOWING TENDER ENQUIRY PROFORMA SHOULD BE DULY FILLED
UP BY THE INTENDING BIDDERS:-**

**I. INFORMATION TO BE FURNISHED BY THE TENDERER FOR
APPRAISAL OF FIRM'S CAPABILITY & CAPACITY TO MANUFACTURE
ITEM (S) EQUIPMENT AS PER REQUIREMENT TO TENDER ENQUIRY**

- 1.0** (A) i) Name of the tendering Firm
(ii) Complete address of the required office
(iii) Telegraphic address
(iv) Phone No.
(v) Fax No.
(vi) Email No.
- (B) (i) Name of the two responsible officers of the firm with designation
(Managing Director / Partner/Chief Engineer / Works Engineer etc.
(ii) Day of which weekly holiday is observed.
- (C) Complete address of the works
(i) Name and Designation of the Chief Executive of the Works and his
immediate junior
(ii) Telephone number(s)
(iii) Email No.
(iv) Fax No.
(v) Day on which weekly holiday is observed.
- 2.0** Year of the Establishment :
- 3.0** Financial Position :
- (A) (i) Land (Area & Value)
(ii) Building (Covered area & value)
(iii) Plant & Machinery (Value in Rs. Lakh)
(iv) Total drawing limit(Certificate from bankers) (Rs. Lakh)
- (B) Annual financial turnover (duly audited for the last two years)
(Rs. Lakhs)
- (C) Latest Income Tax Clearance Certificate.
- 4.0** Manpower : (Nos)
- (a) Graduate Engineer(s)
(b) Diploma holder(s)
(c) Skilled workers
(d) Unskilled workers
- 5.0** Production capacity per month of the item covered in your quotation and
justification for assessment
- (a) Details of plant & machinery installed
(Please attached separate sheets, if necessary).
(b) Details of raw material required.
(c) Source of raw material.
(d) Stock in hand.
(e) Quality controls exercised in procurement of materials.



6.0 Manufacturing process & quality control:-

- (a) Details of manufacturing process.
- (b) Scheme of quality controls
 - (i) During manufacturing process.
 - (ii) At the finished stage
 - (iii) Whether any record is being maintained in respect of quality controls exercised

- 7.0**
- (a) Whether items offered conforms to IS or any other internationally recognized standards, if so, give reference.
 - (b) Whether the firm is licensed to use ISI mark or any other Govt. Quality Mark. (Copies of latest test certificates issued by Govt. Laboratories/any Recognized Test House be attached).

Signature of Authorized
Signatory of the firm
Seal of the firm



II. DETAILS TESTING FACILITIES

Name of Test Remarks	Detail of testing facilities available
1. Test of Raw Materials a) ----- b) -----	
2. Routine Test a) ----- b) -----	
3. Acceptance Test a) ----- b) -----	
4. Type Test a) ----- b) -----	

Name of Firm
Name & Signature
of the tenderer
Designation
Date

Note : In case, testing facilities are not available for certain test, indicate in remarks column from which testing house(S)/institution (s) these tests will be got carried out.



III. DETAILS OF TENDERER'S EXPERIENCE

Tenderer shall furnish here particulars of similar orders executed / under execution by him, to whom a reference may be made by Purchaser, in case such a reference is necessary.

Sl. No.	Name of the client and Description of order	Value of order In Rs.	Period of supply by the tenders against target	Name and address to whom reference may be made
1	2	3	4	5

1.

2.

3.

4.

5.

Name of Firm

Name & Signature
of the authored signatory

Designation

Date

+++++



**PROFORMA OF BANK GUARANTEE FOR
CONTRACT PERFORMANCE
(To be stamped in accordance with stamp Act)**

Ref.

Bank Guarantee No.

Date.....

To

**Tripura State Electricity Corporation Limited
Bidyut Bhavan, North Banamalipur,
Agartala – 799001,
West Tripura.**

Dear Sir,

In consideration of **Tripura State Electricity Corporation Limited** (hereinafter referred to as the ‘Owner’, which expression shall unless repugnant to the context or meaning thereof include its successors, administrators and assigns) having awarded to M/s with its registered / Head office at(hereinafter referred to as ‘Contractor’ which expression shall unless repugnant to the context or meaning thereof, include its successors, administrators, executors and assigns), a Contract by issued of Owner’s Letter of Award No.....dated.....and the same having been acknowledged by the Contractor, resulting in a Contract bearing No.datedvalued atfor(scope of contract) and the Contactor having agreed to provide a Contract Performance Guarantee for the faithful performance of the entire Contract equivalent tobeing .(%) per cent) of the said value of the Contract to the Owner.

We, (Name & Address) having its Head Office at.....(hereinafter referred to as the ‘Bank’, which expression shall, unless repugnant to the context or meaning thereof, include its successors, administrators , executors and assigns) do hereby guarantee and undertake to pay the Owner, on demand any or all monies payable by the Contractor to the extent ofas aforesaid at any time up to ** (see in note below) (days/month/year) without any demur, reservation, contest, recourse or protest and/or without any reference to the Contractor.

Any such demand made by the Owner on the bank shall be conclusive and binding notwithstanding any difference between the Owner and the Contractor or any dispute pending before any Court, Tribunal, Arbitrator or any other authority. The Bank undertakes not to revoke this guarantee during its currency without previous consent of the Owner and further agrees that the guarantee herein contained shall continue to be enforceable till the Owner discharges this guarantee.

The Owner shall have the fullest liberty without affecting in any way the liability of the Bank under the guarantee, from time to time to extend the time for performance or the Contract by the Contractor. The Owner shall have the fullest liberty, without affecting



this guarantee, to postpone from time to time the exercise of any powers vested in them or of any right which they might have against the Contractor, and to exercise the same at any time in any manner, and either to enforce or to for bear to enforce any covenants, contained or implied, in the Contact between the Owner and the Contractor or any other course or remedy or security available to the Owner. The Bank shall not be released to its obligations under these presents by any exercise by the Owner of its liberty with reference to the matters aforesaid or any of them or by reason of any other act of omission or commission on the part of the Owner or any other indulgences shown by the Owner or by any other matter or thing what so ever which under law would, but for this provision have the effect of relieving the Bank.

The bank also agrees that the Owner at its option shall be entitled to enforce this guarantee against the Bank as a principal debtor, in the first instance without proceeding against the Contractor and not withstanding any security or other guarantee the Owner may have in relation to the Contactor's liabilities.

Notwithstanding anything contained herein above our liability under this guarantee is restricted toand it shall remain in force upto and includingand shall be extended from time to time for such period (not exceeding one year), as may be desired M/son whose behalf this guarantee has been given.

Dated this day of200..... At

WITNESS

..... (Signature) (Signature)
..... (Name) (Name)
..... (Official Address) (Official Address)

Attorney as per Power
Of Attorney No.

Date

NOTES:

- **This sum shall be 'ten per cent (10 %)' of the Contact Price.**
- ** **The date will be ninety (90) days after the end of date of 'Warranty Period' as specified in the Contract.**
- 1. The Stamp Papers of appropriate value shall be purchased in the name of issuing Bank.**



APPLICATION FOR EXTENSION OF TIME

(Part – I)

1. Name of Contractor _____
2. Name of work (as given in the contract) _____

3. Agreement no. _____
4. Contract amount _____
5. Date of Commencement of work as per agreement _____
6. Period allowed for completion of work (as per agreement) _____
7. Date of completion stipulated in the agreement _____
8. Actual date of completion _____
9. Period for which extension of time has been given previously if any _____
 - a) 1st extension vide No. _____
 - b) 2nd extension vide No. _____
 - c) 3rd extension vide No. _____
 - d) 4th extension vide No. _____
10. Period for which extension have been previously given (Copies of the previous application should be attached).
11. Hindrances on account of which extension is applied for with date on which hindrances occurred.

Sl. No.	Nature of hindrances	Date of occurrence	Period of which hindrances is likely to last	Extension of time applied for by the contractor	Overlapping period, if any, giving reference to items which overlap	Period for which extension is applied for.	Remarks as to why the hindrances occurred and justification for extension of time

12. Total period for which extension is now applied for on account of hindrances mentioned above.
13. Extension of time required for extra work: - _____ Months. _____ days.
14. Detailed for extra work and the amount involved: -
15.
 - a) Total value of extra work: -
 - b) Proportionate period of extension of time based on estimated amount put to tender on account of extra work: -
16. Total extension of time required for 11 & 12: -

Signature of Contractor



APPLICATION FOR EXTENSION OF TIME

(Part – II)

(To be filled in by TSECL)

1. Date of receipt of application from _____ contractor for the work of _____ in the Sub-Divisional _____.
2. Acknowledgement issued by the Sr. Manager, vide his No. _____ Dated _____.
3. Recommendation of Sr. Manager, in – charge of the Sub-Division is to whether the reasons given by the Contractor are correct and what extension, if any, recommended by him, if he does not recommended the extension, reasons for rejection should be given

Dated

Signature of the Sr. Manager
in-charge of Sub-Division.



APPLICATION FOR EXTENSION OF TIME

(Part – III)

(To be filled in by TSECL)

1. Date of receipt in the Divisional office: _____
2. Report of DGM, in-charge of the Division regarding hindrances mentioned by the contractor _____

Sl. No.	Nature of hindrances	Date of occurrence	Period for which hindrance is likely to last	Extension of time applied for by the contractor	Overlapping period, if any, giving reference to items which overlap	Net extension applied for	Remarks as to why the hindrances occurred and justification for extension recommended

3. Recommendation / Approval of the DGM, in-charge of the Division: -
(The present progress of work should be stated and whether the work is likely to be completed by the date upto which extension is applied for, if extension of time is not recommended, what compensation is proposed to be levied under clause 13 of section - III.

Signature of DGM

4. Recommendation / Approval of the AGM, in-charge of the Circle: -

Signature of AGM

5. Recommendation / Approval of the GM (Technical): -

Signature of GM (Technical)

6. Recommendation / Approval of the CMD: -

Signature of CMD



(N.J. Stamp of Rs.30/-)
BEFORE THE NOTARY
_____ : TRIPURA.

INDEMNITY BOND

THIS INDEMNITY BOND IS EXECUTED ON THE _____ DAY OF _____ 2010 A. D. By Shri _____, S/O. Shri / Late _____, Vill. _____ P.S. _____, District _____, aged about _____ years, a citizen of India (Here-in-after called the Contractor indemnifier) in favour of Tripura State Electricity Corporation Ltd. (TSECL) (Here-in-after called the Corporation) under the terms and conditions here-in-after mentioned :-

WHEREAS, I am a Class __ Government Contractor and the Corporation awarded me to execute the work namely

I agree to indemnify the corporation that in the event of any accident of any workman, arising out of and in course of employment, during execution of the work I shall be liable to pay full compensation to the workmen employed by me for execution of the work.

I also agree to indemnify and save harmless the corporation that, the lives & bodies of my workmen(s), employed by me for execution of this work, are duly insured with the _____ Insurance Company _____ Branch under Act / Scheme.

I further agree to indemnify and save harmless the corporation that the corporation or any of its Director (s) or Officer(s) or Manager(s) shall not be made liable to pay any compensation to any workmen in the event of death or bodily injury, arising out of the in course of employment under me, employed by me for execution of the work namely

IN WITNESS WHERE OF I SIGN THIS INDEMNITY BOND TODAY, THE DAY, MONTH, YEAR FIRST ABOVE WRITTEN IN PRESENCE OF FOLLOWING WITNESSES.

Witnesses 1. 2. Identified by me _____ Advocate	_____ Full Signature of Contractor (INDEMNIFIER)
--	--

(Bidder's Letter Head)



To,
Additional General Manager (DP & C)
Tripura State Electricity Corporation Limited
Bidyut Bhavan, North Banamalipur
Agartala – 799001, Tripura West

Sub: “No Deviation” declaration

Ref: NIT No: ----- Date:

Sir,

I/We hereby accept and abide by the scope & terms and conditions of NIT document unconditionally and on the Scope of Work, or any related area there are no deviations in this response. (---Name of bidder---) has adhered to all the qualification requirements as well as other items listed in the NIT.

Yours faithfully,

Signature: _____
Full Name: _____
Address: _____



**PROFORMA FOR EVIDENCE OF ACCESS TO OR AVAILABILITY OF
CREDIT/FACILITIES (TO BE GIVEN BY BANKER OF BIDDER)**

BANK CERTIFICATE

This is to certify that M/s..... (FULL NAME AND ADDRESS) who are submitting their Bid toagainst their tender specification vide Ref. No..... and dateis our customer for the pastyears.

Their financial transactions with our bank have been satisfactory. They enjoy the following fund based and non fund based limits including guarantees, L/C and other credit facilities with us against which the extent of utilization as on date is also indicated below:

Sl.No.	TYPE OF FACILITY	SANCTIONED LIMIT AS ON DATE	UTILIZATION AS ON DATE.....

This letter is issued at the request of M/s.....

Sd/-

Name of Bank.....

Name of authorized Signatory.....

Designation.....

Phone No.....

Address.....

SEAL OF THE BANK



• SECTION - V

• PRICE BIDDING SCHEDULE

The qualified Bidder(s)/Contractor(s) should duly fill up the schedule of item(s) format. The rate and amount are to be written both in figures and words in such a way that interpolation is not possible. In case of figures, the word Rs. should be written before the figure and Paise at the end (viz. Rs.250.50 p). In case of rate or amount in words, the 'Rupees' should precede and the 'only' should be written at the end (viz. Rupees Two hundred fifty and Paise fifty only).

Price Bidding Schedule							
Name of Work: Procurement of Steel Tubular Poles for implementation of R-APDRP (Part-B) Scheme under Badharghat,Jogendranagar,Pratapgarh,Indranagar & Sonamura Project.Area .							
Ch. To:- R-APDRP(Part-B), Badharghat,Jogendranagar,Pratapgarh,Indranagar & Sonamura Project..							
SI No	Description of items	Supply					
		Qty.	Unit	Unit Rate (in Rs)		Amount (in Rs)	
				(in Figures)	(in Words)	(in Figures)	(in Words)
1	Design, Engineering, Manufacture, Assembly, Inspection, Testing at manufacturer's work before dispatch ,packing, supply & delivery of Steel Tubular Poles conforming to ISS:2713(P-I & II) 1980 with round shape base plate welded at the bottom.						
	a) 11.0 mtr. long pole (IS Designation 410 SP-54)	2270	No				
	b) 9.0 mtr. Long (IS Designation 410 SP-32)	2680	No				
Supply Amount (in Rs.)							



BLANK