

Hex Code Table	
✓ FMXXXX	Length (L)
FM0530	1
FM0531	2
FM0532	3
FM0533	4
FM0534	5
FM0535	6
FM0536	7
FM0537	8
FM0538	9
FM0539	10
FM0540	11
FM0541	12
FM0542	13
FM0543	14
FM0544	15
FM0545	16
FM0546	17
FM0547	18
FM0548	19
FM0549	20
FM0550	21
FM0551	22
FM0552	23
FM0553	24
FM0554	25
FM0555	26
FM0556	27
FM0557	28
FM0558	29
FM0559	30
FM0560	31
FM0561	32
FM0562	33
FM0563	34
FM0564	35
FM0565	36
FM0566	37
FM0567	38
FM0568	39
FM0569	40
FM0570	41
FM0571	42
FM0572	43
FM0573	44
FM0574	45
FM0575	46
FM0576	47
FM0577	48
FM0578	49
FM0579	50
FM0580	51

Metric Spacers 6 mm

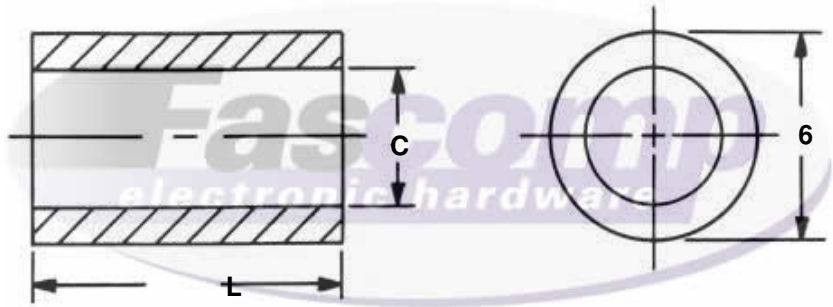

Create a part number:

Length	Clearance	Material	Finish
FMXXXX	XX	XX	XX

Hole Clearance Code (XX)			
✓	Code (XX)	Thread	C +0.3 -0.0
	3	M3	3.2
	35	M3.5	3.7
	4	M4	4.3

Material	
✓	Material Code (XX)
A	Aluminum
B	Brass
S	Steel
SS	Stainless Steel
N	Nylon

**Tolerances
Unless otherwise Specified**
 .xxx +/- .13mm
 .xx +/- .26mm
 Angular +/- 1 Degree
 Linear +/- .13mm
Break all sharp edges

✓ Compatible Finish	
A, B, S, SS	0 - Plain
B, S	5 - Nickel Plate (QQ-N-290)
A	6 - Iridite #14 Gold (MIL-C-5541E)
A	7 - Iridite Clear (MIL-C-5541E)
A	9 - Alodine 1200
B, S	12 - Zinc Clear (ASTM-B-633)
B, S	16 - Electro Tin (MIL-T-10727 TYPE 1)
SS	20 - Passivation (MIL-F-14072D)
A	22 - Clear Anodize (MIL-A-8625-TYPE2) (Sulphuric) Hot Water Seal (Clear)
A	24 - Black Anodize (MIL-A-8625)
B, S, SS	26 - Black Oxide
B, S	28 - Zinc Yellow (ASTM-B-633)



Fascomp Electronic Hardware
 7814 Kingspointe Pkwy
 Orlando, FL 32819
 www.fascomp.com
 Tel: (407) 226-2112
 Fax: (407) 226-3370

Source Control Drawing:
 To be produced by
 Fascomp Electronic Hardware

This document is the property of Fascomp Inc. and shall not be reproduced, distributed, or used as a basis for manufacturing without written permission from Fascomp Inc.