

Hex Code Table		
✓ FMXXXX	Length (L)	
FM0590	1	
FM0591	2	
FM0592	3	
FM0593	4	
FM0594	5	
FM0595	6	
FM0596	7	
FM0597	8	
FM0598	9	
FM0599	10	
FM0600	11	
FM0601	12	
FM0602	13	
FM0603	14	
FM0604	15	
FM0605	16	
FM0606	17	
FM0607	18	
FM0608	19	
FM0609	20	
FM0610	21	
FM0611	22	
FM0612	23	
FM0613	24	
FM0614	25	
FM0615	26	
FM0616	27	
FM0617	28	
FM0618	29	
FM0619	30	
FM0620	31	
FM0621	32	
FM0622	33	
FM0623	34	
FM0624	35	
FM0625	36	
FM0626	37	
FM0627	38	
FM0628	39	
FM0629	40	
FM0630	41	
FM0631	42	
FM0632	43	
FM0633	44	
FM0634	45	
FM0635	46	
FM0636	47	
FM0637	48	
FM0638	49	
FM0639	50	
FM0640	51	

Metric Spacers 8 mm

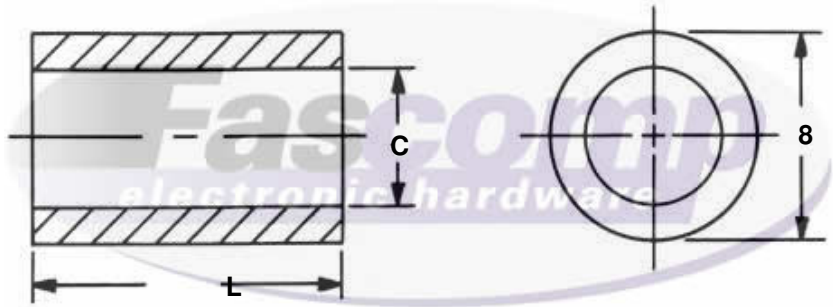

Create a part number:

Length	Clearance	Material	Finish
FMXXXX	XX	XX	XX

Hole Clearance Code (XX)			
✓	Code (XX)	Thread	C +0.3 -0.0
	3	M3	3.2
	35	M3.5	3.7
	4	M4	4.3
	5	M5	5.3

Material		
✓	Material Code (XX)	
	A	Aluminum
	B	Brass
	S	Steel
	SS	Stainless Steel
	N	Nylon

**Tolerances
Unless otherwise Specified**
 .xxx +/- .13mm
 .xx +/- .26mm
 Angular +/- 1 Degree
 Linear +/- .13mm
Break all sharp edges

✓	Compatible Finish	
	A, B, S, SS	0 - Plain
	B, S	5 - Nickel Plate (QQ-N-290)
	A	6 - Iridite #14 Gold (MIL-C-5541E)
	A	7 - Iridite Clear (MIL-C-5541E)
	A	9 - Alodine 1200
	B, S	12 - Zinc Clear (ASTM-B-633)
	B, S	16 - Electro Tin (MIL-T-10727 TYPE 1)
	SS	20 - Passivation (MIL-F-14072D)
	A	22 - Clear Anodize (MIL-A-8625-TYPE2) (Sulphuric) Hot Water Seal (Clear)
	A	24 - Black Anodize (MIL-A-8625)
	B, S, SS	26 - Black Oxide
	B, S	28 - Zinc Yellow (ASTM-B-633)



Fascomp Electronic Hardware
 7814 Kingspointe Pkwy
 Orlando, FL 32819
 www.fascomp.com
 Tel: (407) 226-2112
 Fax: (407) 226-3370

Source Control Drawing:
 To be produced by
 Fascomp Electronic Hardware

This document is the property of Fascomp Inc. and shall not be reproduced, distributed, or used as a basis for manufacturing without written permission from Fascomp Inc.