

R&S® STANAG 5066 HF Radio Data Communications System E-mail and IP connectivity via HF radio networks

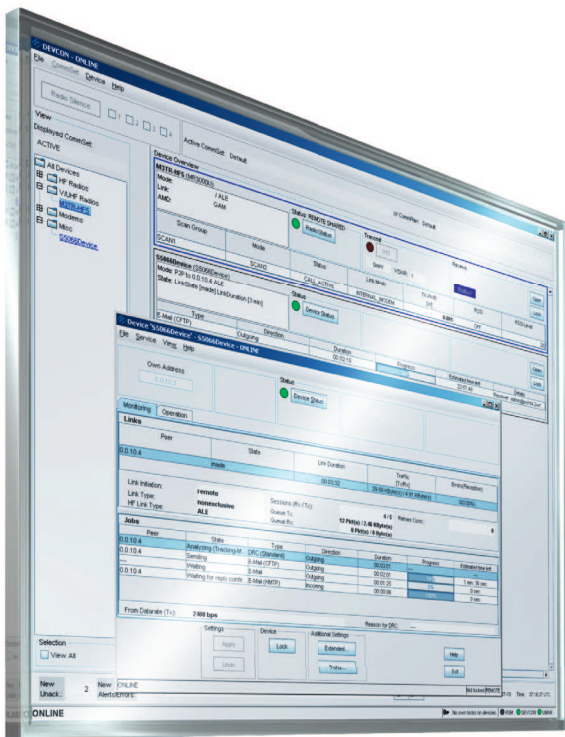

R&S®STANAG 5066

HF Radio Data Communications System

At a glance

Global data communications

The exchange of e-mail and IP-based information is vital for the successful planning and execution of military operations. Interoperable data exchange within joint and allied forces over long-distance HF radio networks is essential, especially if communications via other infrastructures such as satellites is unavailable, too expensive or vulnerable.

STANAG 5066 is the leading NATO radio protocol for HF data communications. The standard is widely accepted and used by the forces of NATO, PfP (partnership for peace) and other nations around the globe.

R&S®STANAG 5066 data communications system

R&S®STANAG 5066 is a communications solution for the robust and highly secure exchange of data using HF radio networks in line with STANAG 5066.

R&S®STANAG 5066 supports data exchange via e-mail, chat, fax and IP-based applications. It controls radios from Rohde&Schwarz as well as from other suppliers. A unique red/black separation technique using crypto devices and trusted filters satisfies the highest security demands. Interoperability with the widely used ACP 127 legacy message handling system is supported by means of a gateway.

R&S®STANAG 5066 is fully integrated in the R&S®SIMCOS II signal management and control system and is an important component of the R&S®MMHS military message handling system.

R&S®STANAG 5066 is deployed in a variety of customer systems where it has proven its standard-conforming data exchange capability. Interoperability with other STANAG 5066 systems has also been demonstrated during international HF radio trials.

Key facts

- Highest security level
- Extended remote control and monitoring features
- Optimal system integration capabilities
- Support of legacy ACP 127 systems



R&S®STANAG 5066

HF Radio Data Communications System

Benefits and key features

R&S®STANAG 5066 is a powerful HF radio data communications solution that boasts the following features:

Interoperability

- Proven interoperability with other STANAG 5066 solutions available on the market
- Interoperable with BFEM 66

▷ [page 4](#)

Integrated communications system (ICS) solution together with R&S®SIMCOS II

- Highly integrated solution for efficient and powerful control and management of HF radiocommunications

▷ [page 5](#)

Highest security level

- Proven red/black separation using crypto equipment and trusted filters
 - Support of various crypto equipment
 - Integration of trusted filters
 - Security accreditation procedures

▷ [page 6](#)

Expansion of IP connections via HF radio lines

- Use of IP-based customer applications via HF radio networks
- Support of IP type-of-service (TOS) field
- Support of IP unicast, multicast and broadcast

▷ [page 7](#)

Efficient e-mail and fax transmission

- Transmission of e-mails and faxes via HF radio networks
- Available STANAG 5066 e-mail clients
 - STANAG 5066 CFTP client
 - STANAG 5066 HMTP client
- Integrated standard e-mail server
- Interoperability with standard e-mail programs
- Reliability in HF radio transmissions
- Fax transmission

▷ [page 8](#)

Interoperability with legacy applications

- Support of legacy message handling (ACP 127)
- COSS client
- ACP 127 support
 - Reliable data exchange
 - Delivery confirmation message

▷ [page 10](#)

HF chat for simplified information exchange

- Alternative to e-mail
- Easy and fast information exchange
- Orderwire messages

▷ [page 11](#)

Mastery of changing HF transmission conditions

- Methods for automatically adapting to various HF transmission conditions
- Selection of the optimal configuration prior to a transmission
- Adaptive data rate change during a transmission

▷ [page 12](#)

Remote system control and monitoring

- Support of various HF equipment
- Integration of customer HF equipment
- Synchronous serial data interfaces
- Full remote control and monitoring

▷ [page 13](#)

Interoperability

Proven interoperability with other STANAG 5066 solutions available on the market

R&S®STANAG 5066 has been successfully deployed by a variety of customers and has also demonstrated its data exchange capability and its interoperability with other STANAG 5066 systems during international HF radio trials. R&S®STANAG 5066 is fully compliant with STANAG 5066, edition 1.2, amendment 1.

Interoperable with BFEM 66

R&S®STANAG 5066 is interoperable with NATO's widely used BFEM 66 e-mail transmission system.

Interoperability of R&S®STANAG 5066 with other STANAG 5066 solutions



Integrated communications system solution together with R&S®SIMCOS II

R&S®STANAG 5066, together with R&S®SIMCOS II, creates a powerful combination of communications, control and management functions for naval applications.

Highly integrated solution for efficient and powerful control and management of HF communications

As part of an integrated communications system (ICS) solution, R&S®STANAG 5066 provides the communications (message handling) capability while the R&S®SIMCOS II signal management and control system handles the management and control functions.

In this environment, R&S®STANAG 5066 is integrated into the planning, monitoring, fault management and remote control mechanisms of the R&S®SIMCOS II.

For ICS solutions with two or more STANAG 5066 radio lines, each line requires a separate R&S®STANAG 5066 system.

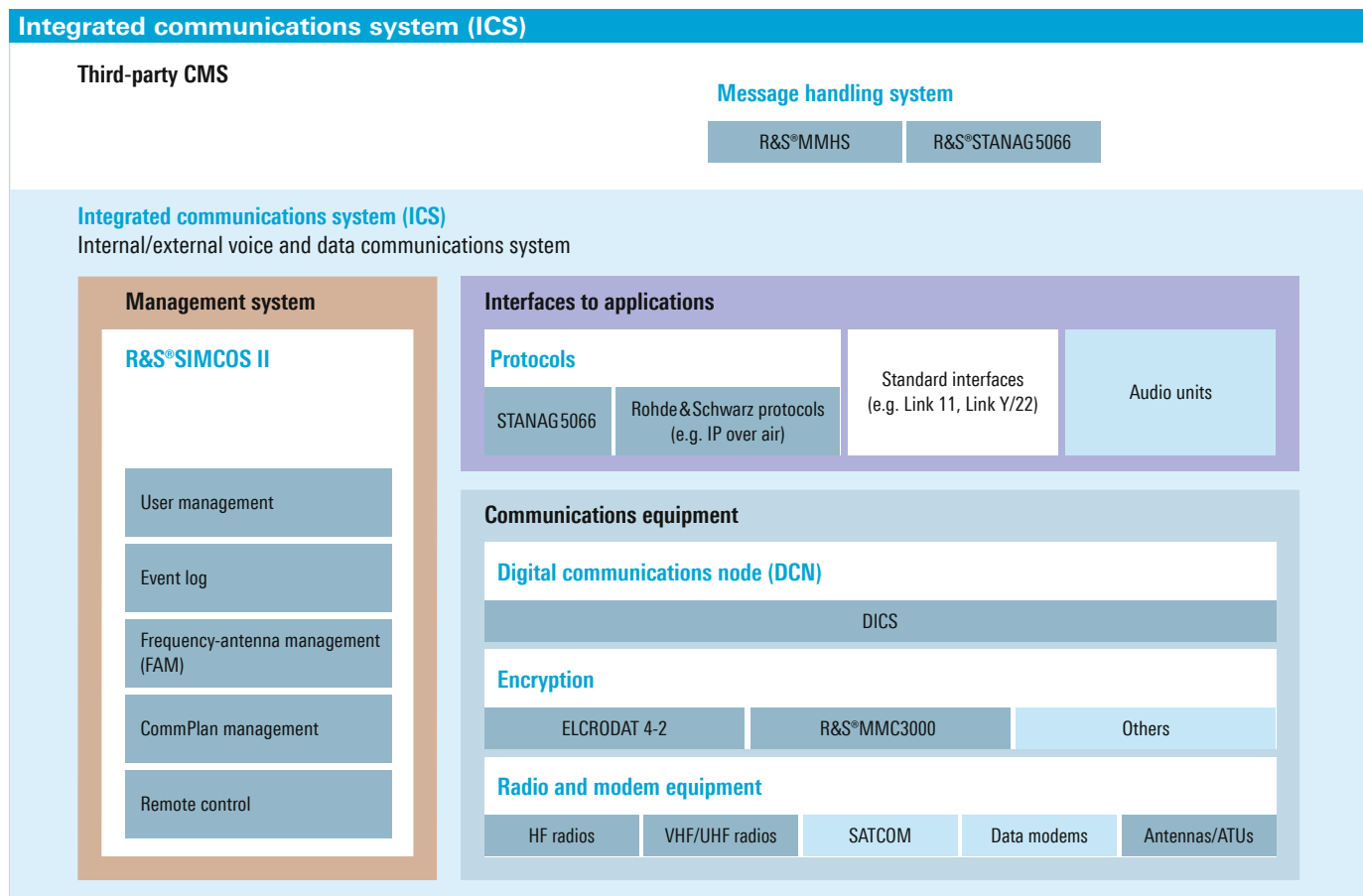

Highest security level

Proven red/black separation using crypto equipment and trusted filters

R&S®STANAG 5066 meets the most stringent customer security requirements by providing strict red/black separation through modern crypto devices and trusted filters in the control lines.

Support of various crypto equipment

For the encryption of mission-critical data, external online crypto devices can be installed on the data path between the R&S®STANAG 5066 server (red side) and the HF radio/modem (black side).

The following crypto devices are supported:

- ELCRODAT 4-2
- R&S®MMC3000
- BID 1650
- Crypto AG HC 2650

Other crypto devices can be integrated on request.

Integration of trusted filters

To support full red/black separation for HF data communications systems, Rohde & Schwarz provides a trusted filter. This filter is inserted into the remote control path between the R&S®STANAG 5066 server and the HF radio or modem. Only a limited and precisely defined set of remote control commands are allowed to pass through. The trusted filter will block any other data that appears on the serial control lines. A list of supported radios and modems is available. Additional devices can be supported on request.

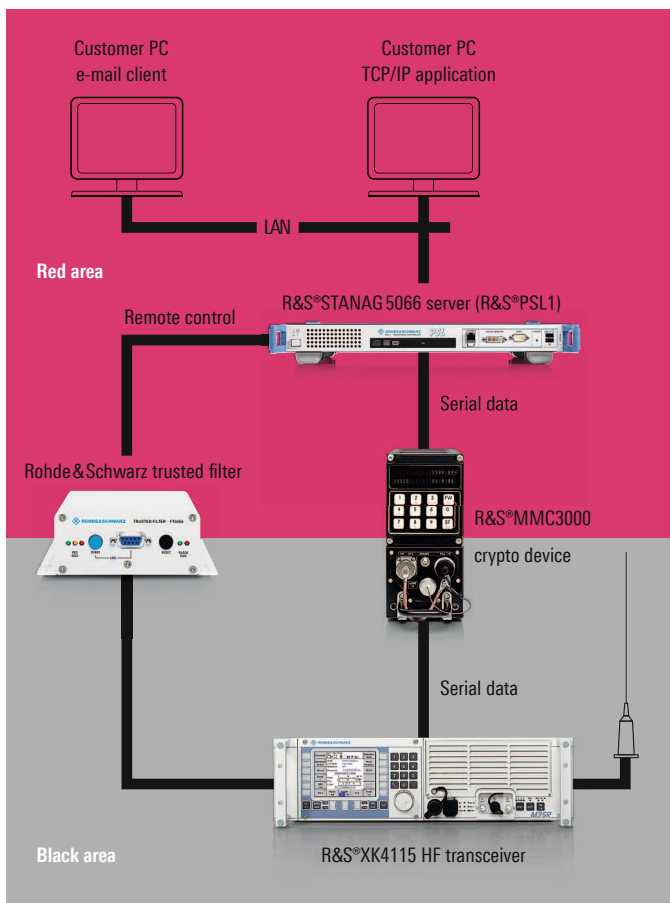

Highest security level.

Expansion of IP connections via HF radio lines

Use of IP-based customer applications via HF radio networks

R&S®STANAG 5066 enables LAN/WAN IP-based customer applications to communicate via wireless HF networks. TCP/UDP/IP-based data exchange is provided for various IP applications. However, the limited data throughput and the larger transmission delay of HF radio links must be taken into consideration. These constraints influence the type of TCP/UDP/IP-based applications that can reasonably be supported over HF.

Support of IP type-of-service (TOS) field

The STANAG 5066 standard calls for support of version 4 of the IP protocol (IPv4). To ensure the most suitable radio link service for the HF radio transmission, based on data priority and reliability, the R&S®STANAG 5066 IP client supports the type-of-service (TOS) field in the IP header and interprets it as a differentiated service field. If the customer application and the underlying TCP/UDP/IP operating system support the relevant settings in this IP header field, the information is used by R&S®STANAG 5066 to classify different IP packets. This is done by mapping the IP data packets to different radio link services as provided by the STANAG 5066 protocol stack.

Support of IP unicast, multicast and broadcast

R&S®STANAG 5066 supports IP unicast as well as IP multicast and IP broadcast data transmissions. IP multicast makes efficient use of the STANAG 5066 multicast capability if two or more recipients are in the same HF network. All IP unicast and multicast addresses must be statically preconfigured to match the corresponding STANAG 5066 node or group addresses.

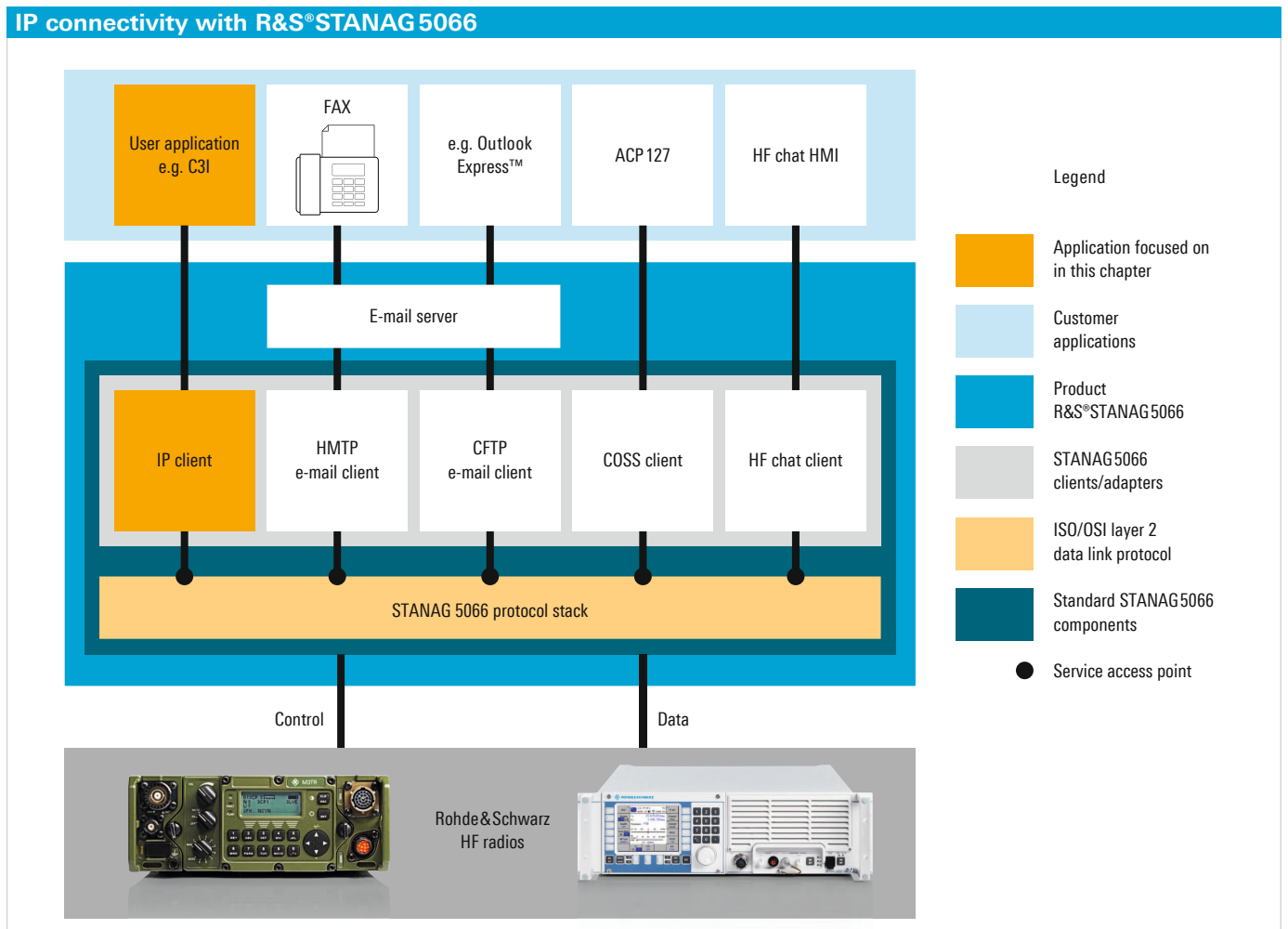

Efficient e-mail and fax transmission

Transmission of e-mails and faxes via HF radio networks

R&S®STANAG 5066 supports the exchange of plain-text e-mails and attachments using the STANAG 5066 CFTP or HMTF clients. STANAG 5066 clients are defined as adapters that applications can connect to.

Available STANAG 5066 e-mail clients

STANAG 5066 CFTP client

The compressed file transfer protocol (CFTP) client provides the most bandwidth-efficient exchange of data. For this reason, CFTP is the preferred client for the transmission of e-mails via HF.

STANAG 5066 HMTF client

The HF mail transfer protocol (HMTF) client is an alternative for the exchange of e-mails. HMTF was standardized much earlier than CFTP and can thus be found in many older STANAG 5066 implementations. Because HMTF is less bandwidth-efficient than CFTP, it is recommended for e-mail transmissions only if interoperability with older STANAG 5066 installations is an issue.

Interoperability of R&S®STANAG 5066 with other STANAG 5066 solutions

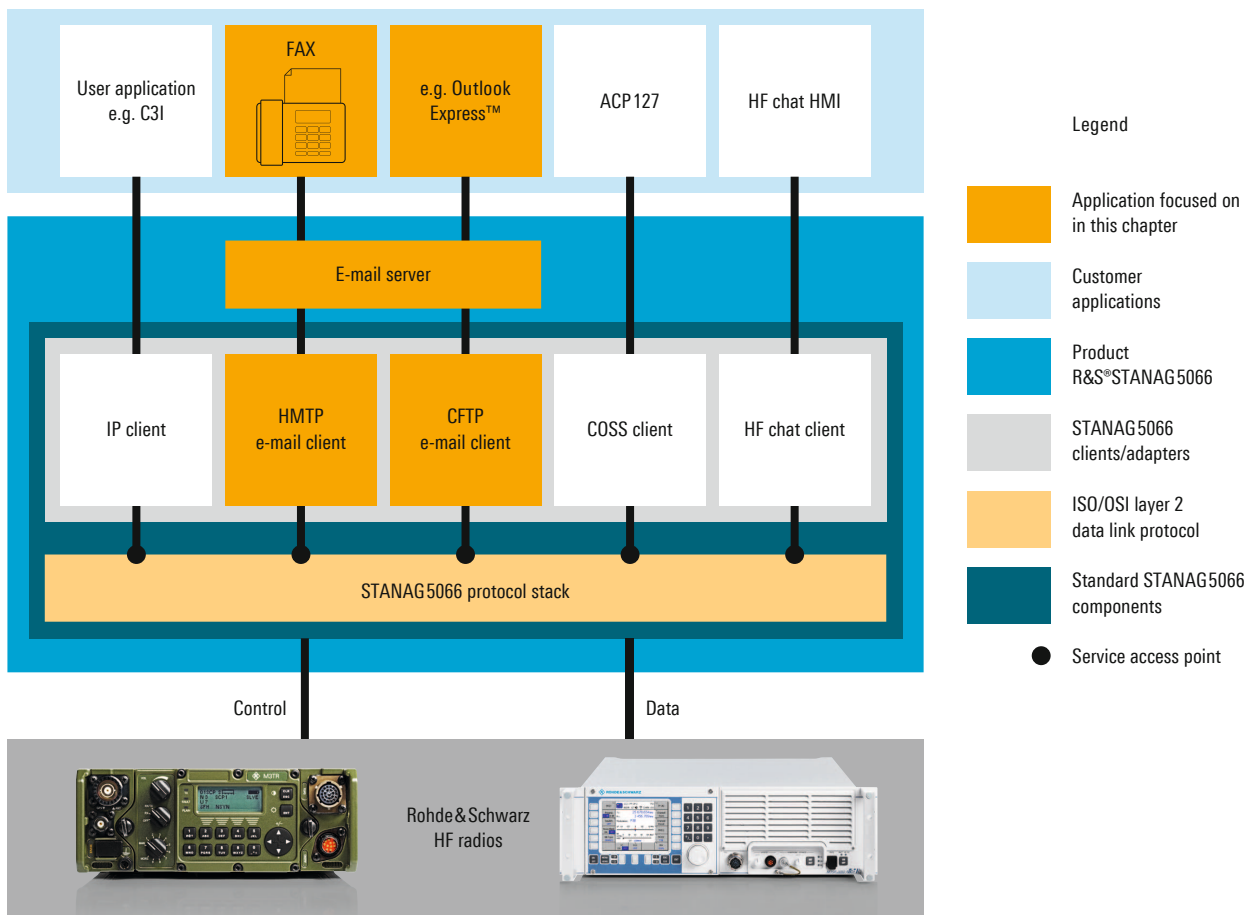

Integrated standard e-mail server

R&S®STANAG 5066 features a standard e-mail server, which provides SMTP/POP3/IMAP services.

Interoperability with standard e-mail programs

Customers' e-mail programs such as Windows Outlook Express™, which are not included with R&S®STANAG 5066, can be configured to connect directly to the R&S®STANAG 5066 e-mail server.

Reliability in HF radio transmissions

When an e-mail is forwarded to the R&S®STANAG 5066 e-mail server, the server must ensure reliable transmission of this e-mail over the HF network. If HF transmission conditions do not allow immediate error-free delivery, multiple automatic retries are performed.

If the server is not able to transmit the e-mail within a predefined period (configurable from several minutes to several hours), it automatically generates an SMTP-based delivery failure notification and returns it to the originator of the e-mail.

Fax transmission

R&S®STANAG 5066 supports Group 3 fax transmission via HF radio networks. Fax messages in line with CCITT standards T.30 and T.4 are converted and transmitted as e-mail attachments. The R&S®STANAG 5066 e-mail option (HMTP/CFTP) is a prerequisite for providing this fax service.

The fax can be generated electronically by an e-mail client or placed in a fax machine as a hardcopy. Faxes can be transmitted worldwide if access to the public switched telephone network (PSTN) is available. Faxes from a regular fax machine connected to a PSTN can also be received.

The fax transmission capability requires that a separate fax machine, a fax modem and a telephone system, neither of which are included with R&S®STANAG 5066, be connected to the R&S®STANAG 5066 server.

Interoperability with legacy applications

ACP 127 support

In military applications, formal message handling in line with ACP 127 is widely used. The COSS client provides two enhancements for ACP 127 message exchange.

Reliable data exchange

ACP 127 exchanges text messages without using any error detection or correction mechanisms. In order to reduce the effort required for manual error correction, the R&S®STANAG 5066 COSS client provides an ARQ method, which allows automatic repetition of corrupted data packets for point-to-point communications.

Delivery confirmation message

ACP 127 automatically generates a delivery status message to the originator to confirm successful message transmission. The ACP 127 delivery confirmation message is an optional extension of the STANAG 5066 standard.

Support of legacy message handling (ACP 127)

COSS client

R&S®STANAG 5066 provides a character-oriented serial stream (COSS) client to integrate applications based on serial line communications (e.g. ACP 127) for interoperable HF data exchange.

This COSS client provides a serial interface for applications that exchange data according to any serial data format defined in annex F of the STANAG 5066 standard.

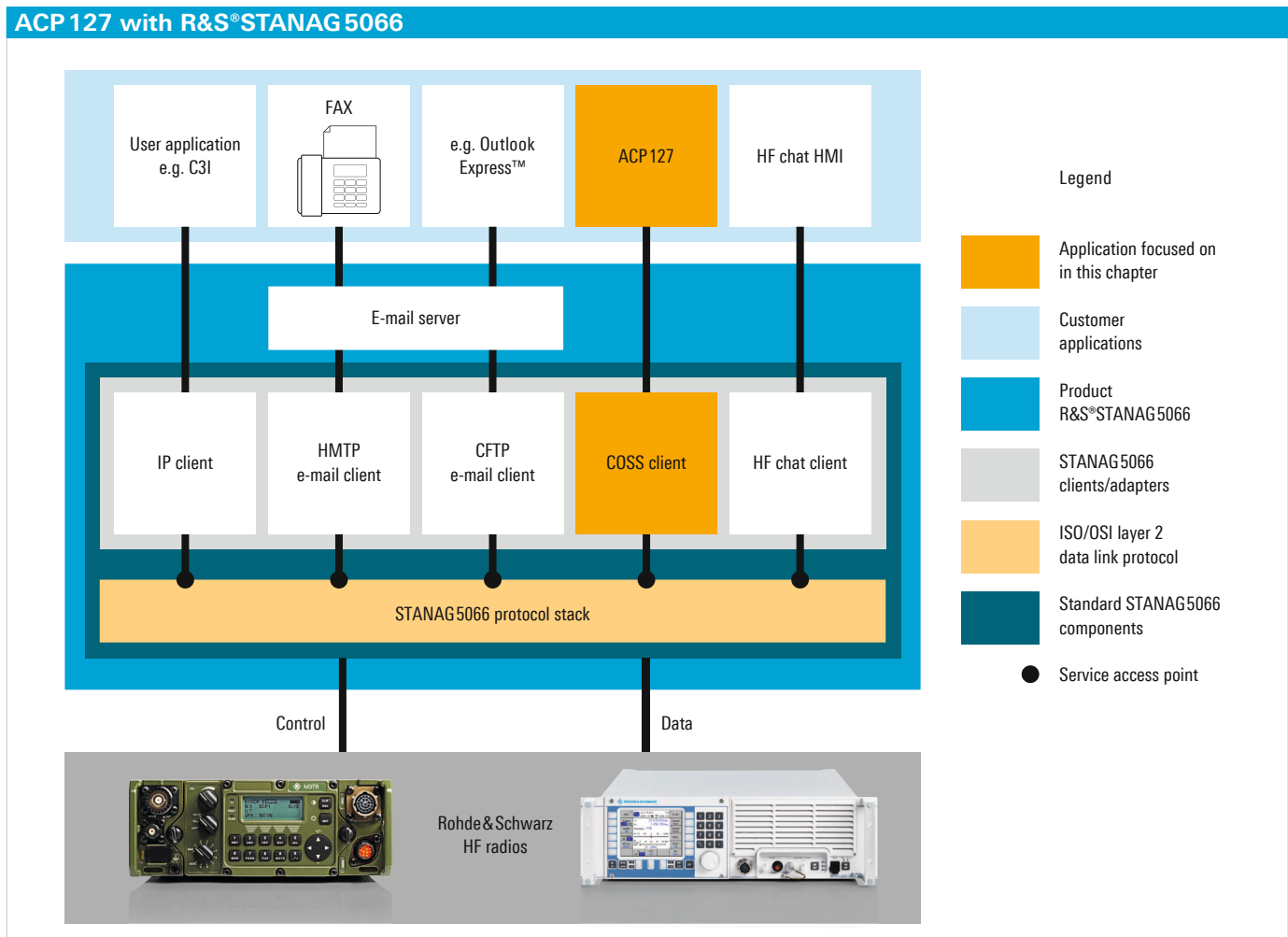

HF chat for simplified information exchange

Alternative to e-mail for easy and fast information exchange

Easy and fast information exchange

R&S®STANAG 5066 features an HF chat application that conforms to the STANAG 5066 standard. R&S®STANAG 5066 HF chat allows simple ASCII text-based message exchange using unicast, multicast or broadcast addressed HF radio transmission to one or more STANAG 5066 stations.

Orderwire messages

HF chat is mainly used for orderwire messages to check the communications settings of the partners during mission setup.

Chat with R&S®STANAG 5066

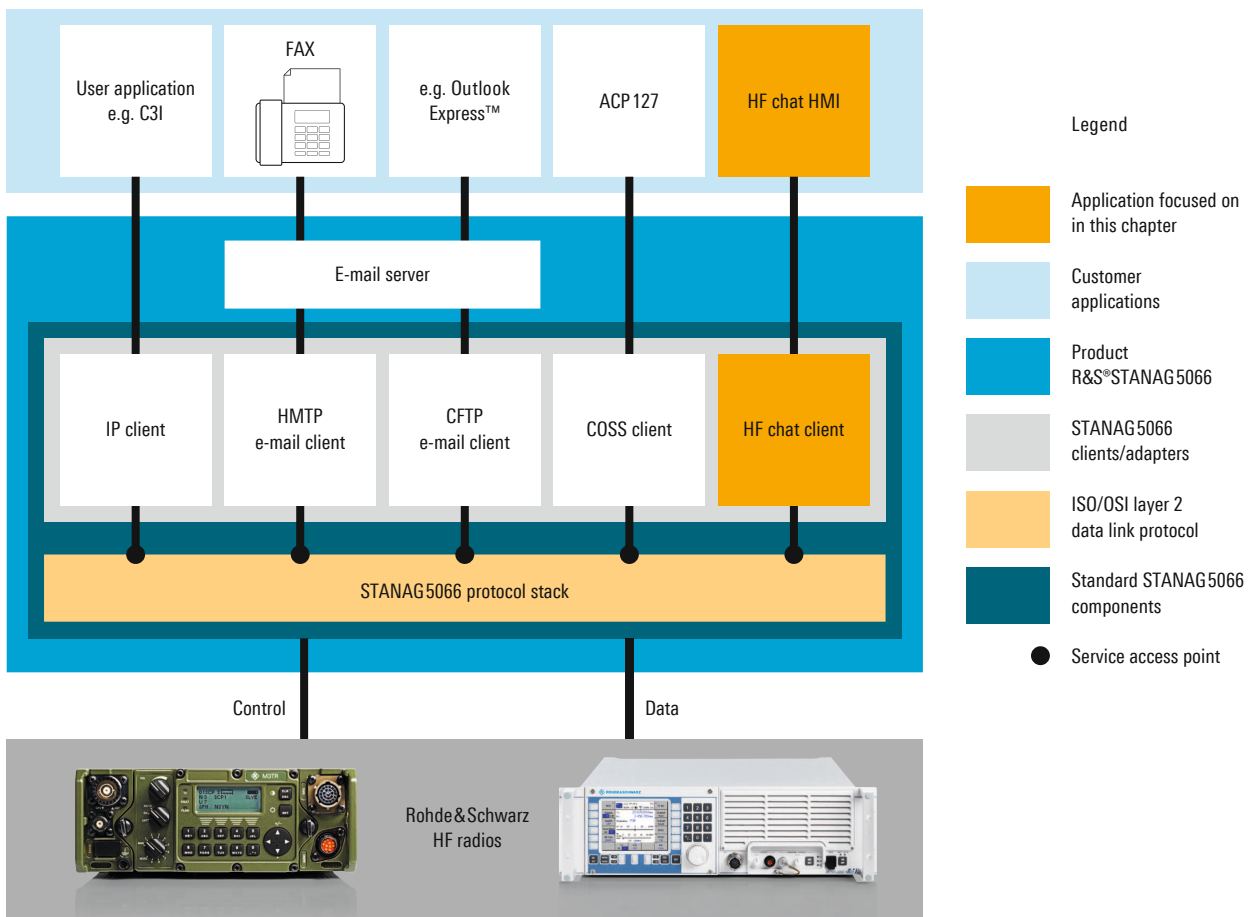

Mastery of changing HF transmission conditions

Methods for automatically adapting to various HF transmission conditions

Long-haul HF communications are subject to a wide range of different and time-dependent HF propagation and transmission conditions. R&S®STANAG 5066 automatically manages most of these changing HF conditions, meaning the operator does not require in-depth knowledge of HF radiocommunications.

Selection of the optimal configuration prior to a transmission

A prerequisite for efficient HF data transmission is the definition of suitable STANAG 5066 protocol timing and configuration parameters for the various HF transmission conditions. For this reason, R&S®STANAG 5066 allows the definition of preconfiguration sets. The operator simply selects the configuration that best matches the expected HF propagation conditions.

Adaptive data rate change during a transmission

Adaptive data rate change (ADRC) uses an intelligent algorithm to select the optimal data rate for reliable and efficient data communications. The appropriate data rate depends on the current HF radio propagation conditions, which can change considerably within a short period of time.

Automatic data rate change

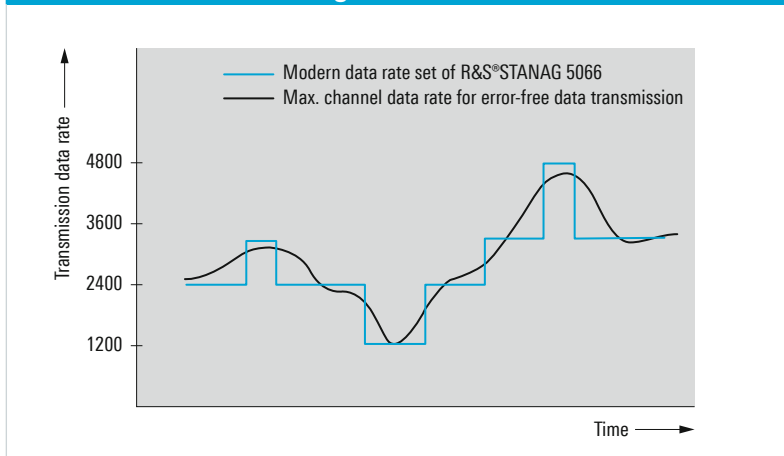

Remote system control and monitoring

Support of various HF equipment

R&S®STANAG 5066 supports various HF transceivers and modems with synchronous or asynchronous data interfaces.

Supported HF radios

The following Rohde & Schwarz HF transceiver families (including the built-in modems) are supported:

- R&S®M3SR Series 4100
- R&S®Series 2000¹⁾
- R&S®M3TR

Supported external HF modems

- DRS GA123A¹⁾
- Rapid Mobile RM6
- Harris RF 5710A

Supported waveforms

- STANAG 4539 annex B
- STANAG 4285
- STANAG 4529
- MIL-STD-188-110A
- MIL-STD-188-110B appendix C²⁾, appendix F

Integration of customer HF equipment

For customers with HF radios or crypto devices not yet supported by R&S®STANAG 5066, integration of their equipment is available on request.

Synchronous serial data interfaces

Most crypto devices use a synchronous serial data interface at their data terminal equipment (DTE), which handles the “red” data from and to the R&S®STANAG 5066 server. To support this functionality, R&S®STANAG 5066 features the optional R&S®GR110 asynchronous/synchronous converter. The R&S®GR110 is recommended even without crypto devices, because its use can reduce the data volume by at least 20 percent compared to asynchronous mode.

Full remote control and monitoring

R&S®STANAG 5066 simultaneously provides both data transmission as well as comprehensive remote control and monitoring of the entire R&S®STANAG 5066 system

Extensive remote control capabilities

In addition to the STANAG 5066 control commands (e.g. data rate change), R&S®STANAG 5066 features extended remote control of the radios and modems as well as of the STANAG 5066 clients and the protocol stack.

Administrators can easily configure the system (fully integrated into the R&S®STANAG 5066 HMI) for a specific mission by adapting the required settings for the following:

- R&S®STANAG 5066 clients
- CFTP, HMTP, chat, IP, COSS
- HF radios
- HF modems

Extensive monitoring capabilities

During active HF data transmissions the system status is monitored and displayed. The following information is provided, for example:

- Queue of incoming/outgoing messages
- Current data transmission error rate
- Actual data transmission rate
- Current links

The parameter settings can be efficiently optimized using this information.

Continuous system monitoring capabilities

Monitoring mechanisms periodically check the system components for malfunctions. Problems are indicated to enable the user to take action or perform fault management.

¹⁾ Two operating modes with STANAG 4539 annex B: 75 bps to 2.4 kbps or 3.2 kbps to 9.6 kbps.

²⁾ Data rates in line with STANAG 4539 annex B.

R&S®STANAG 5066 Technology

Full compliance with STANAG 5066, edition 1.2, amendment 1

Layer model defined in STANAG 5066

R&S®STANAG 5066 is designed as a modular multiuser system consisting of a data link protocol and various STANAG 5066 clients. These clients feature standard application interfaces and connect to the STANAG 5066 HF radio protocol via service access points (SAP). The implemented data link protocol architecture is fully compliant with the sublayer model defined in the STANAG 5066 standard:

- ▮ Subnet interface sublayer – SIS
- ▮ Channel access sublayer – CAS
- ▮ Data transfer sublayer – DTS

This model supports point-to-point, point-to-multipoint and broadcast communications.

Transmission services of the STANAG 5066 radio protocol

The interface between the STANAG 5066 protocol and its clients is formed by a standardized subnetwork interface sublayer (SIS). The SIS enables the clients to request ARQ and non-ARQ data link services.

ARQ transmission for reliable data exchange

When data transmission reliability is critical, e.g. for e-mail or TCP/IP data, the corresponding STANAG 5066 client requests an automatic repeat request (ARQ) data link service. ARQ services are provided for applications that use bidirectional (point-to-point) data communications. As the HF channel is prone to transmission errors, the ARQ mode ensures reliable transfer of user data at the risk of possible retransmission, which can result in major delay variations for the data transfer.

Non-ARQ transmission for time-critical data exchange

For more time-critical applications, e.g. for UDP/IP data or chat, the non-ARQ modes speed up delivery of the data at the risk of receiving incomplete data packets.

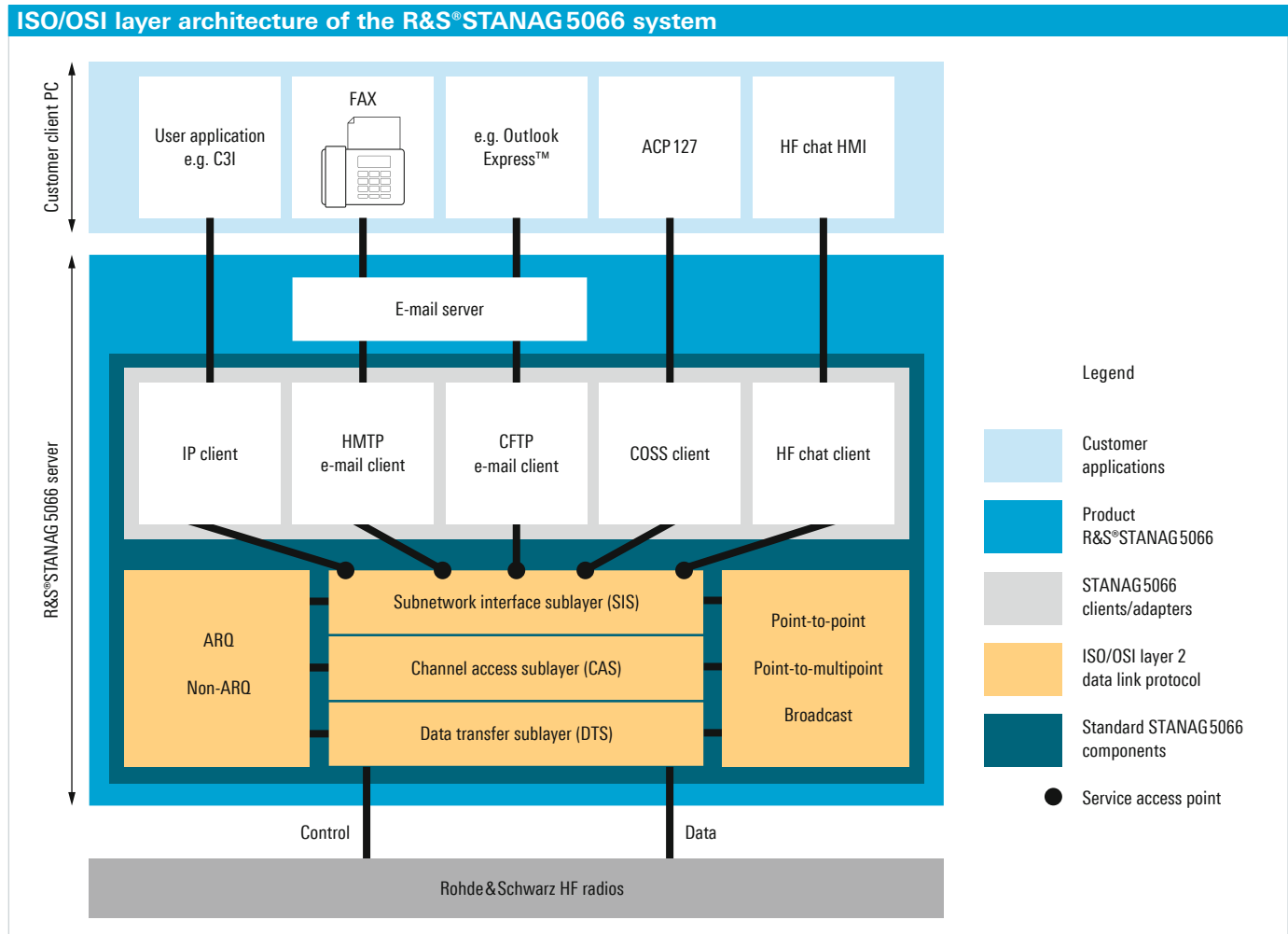

Product overview

Designation	Type
Required components	
R&S®STANAG 5066 Server Software, including one client (for one radio link), IP connectivity (IP client), remote control of R&S®XK2000/M3SR Series 4100/M3TR radios and STANAG 4285/STANAG 4539 waveforms	R&S®DS3600
Software options	
R&S®STANAG 5066 clients	
E-Mail Function with R&S®STANAG 5066 HMTP and CFTP clients	R&S®DS3602
Chat Function with R&S®STANAG 5066 HF chat	R&S®DS3603 ¹⁾
R&S®STANAG 5066 COSS Adapter (e.g. for connection to an ACP 127 system)	R&S®DS3604
Documentation	
Printed manual "Getting started"	
Printed manual "R&S®STANAG 5066 operation"	
Manual on CD "R&S®STANAG 5066 Getting started"	
Manual on CD "R&S®STANAG 5066 operation"	
Customer-specific services	
Installation of R&S®STANAG 5066 on the R&S®PSL 1	
Creation of one R&S®STANAG 5066 configuration	
Hardware option	
Asynchronous/Synchronous Converter	R&S®GR110

¹⁾ Available on request.

Your local Rohde & Schwarz expert will help you determine the optimum solution for your requirements and will be glad to provide you with a customized quotation.

To find your nearest Rohde & Schwarz representative, visit www.sales.rohde-schwarz.com

Service you can rely on

- ▮ Worldwide
- ▮ Local and personalized
- ▮ Customized and flexible
- ▮ Uncompromising quality
- ▮ Long-term dependability

About Rohde & Schwarz

Rohde & Schwarz is an independent group of companies specializing in electronics. It is a leading supplier of solutions in the fields of test and measurement, broadcasting, radiomonitoring and radiolocation, as well as secure communications. Established more than 75 years ago, Rohde & Schwarz has a global presence and a dedicated service network in over 70 countries. Company headquarters are in Munich, Germany.

Environmental commitment

- ▮ Energy-efficient products
- ▮ Continuous improvement in environmental sustainability
- ▮ ISO 14001-certified environmental management system

Certified Quality System
ISO 9001

Certified Quality System
AQAP-2110

Rohde & Schwarz GmbH & Co. KG

www.rohde-schwarz.com

Regional contact

- ▮ Europe, Africa, Middle East | +49 89 4129 12345
customersupport@rohde-schwarz.com
- ▮ North America | 1 888 TEST RSA (1 888 837 87 72)
customer.support@rsa.rohde-schwarz.com
- ▮ Latin America | +1 410 910 79 88
customersupport.la@rohde-schwarz.com
- ▮ Asia/Pacific | +65 65 13 04 88
customersupport.asia@rohde-schwarz.com
- ▮ China | +86 800 810 8228/+86 400 650 5896
customersupport.china@rohde-schwarz.com

R&S® is a registered trademark of Rohde & Schwarz GmbH & Co. KG
Trade names are trademarks of the owners | Printed in Germany (wb)
PD 5213.9634.12 | Version 02.00 | July 2013 | R&S®STANAG 5066

Data without tolerance limits is not binding | Subject to change

© 2009 - 2013 Rohde & Schwarz GmbH & Co. KG | 81671 München, Germany



5213963412