

# VFD B2009

Operation Manual

# Forword

Thank you for choosing Toyo VFDB2009 series dynamic brake unit.

This instruction manual contains information regarding the VFDB2009 series dynamic brake unit. For correct use, please carefully read this instruction manual prior to using the VFDB2009 series dynamic brake unit.

In order to accommodate the many special functions to a wide variety of applications in addition to the inverter functions, please thoroughly read the VF66B inverter manual as well as any other applicable specialized instruction manuals.

# Please read before use

## For safety

Before installing, operating, maintaining and inspecting VFDB2009 series dynamic brake unit, please read this manual and all other appendices thoroughly in order to get familiarize with the feature of this option, safety information and correct handling. In this instruction manual, the safety instructions are classified in to two levels: DANGER and CAUTION. These signs have important instructions. Please follow the instructions without fail.



**DANGER**

Indicates a hazardous situation which may result in death or serious injury if it is handled improperly.



**CAUTION**

Indicates a hazardous situation which may result in moderate or minor injury or only in property damage if it is handled improperly. However, such a situation may lead to serious consequences depending on circumstances.



**CAUTION** [Installation]

- Mount on the nonflammable material as metal, etc.  
Doing so may cause a fire.
- Do not place any flammable materials near the DB unit.  
Doing so may cause a fire.
- DB unit is an open structure, it is put into panel and it is carried out as a turning-on-electricity part.  
Failure to do so may cause an electric shock.
- Do not carry with the option cover.  
Doing so may lead to personal injury by dropping.
- Install the DB unit at durable place against weight.  
Doing so may lead to personal injury by dropping.
- Do not install or operate the DB unit if it is damaged or has any of its parts missing.  
Doing so may lead to personal injury.



**DANGER** [Wiring]

- Before wiring, make sure the power is OFF.  
Failure to do so may cause an electric shock or fire.
- Make sure that the unit is correctly earthed.  
Failure to do so may cause an electric shock or fire.
- Wiring must be done by skilled technicians.  
Failure to do so may cause an electric shock or fire.
- Wire the unit after it is installed.  
Failure to do so may lead to personal injury or cause a fire.



**CAUTION** [Wiring]

- Please check that the voltage setting change of DB unit is in agreement with inverter power supply voltage. (「5.2.1 Change of a power supply voltage」 and 「5.4.3 F20 (Power supply voltage selection · Master / slave selection · Station number set-up mode)」 are refer to.)  
Failure to do so may cause an electric shock or fire.

## **DANGER** [Operation]

- Turn the power ON after close the panel door. Do not open the panel door while the power is ON.  
Doing so may cause an electric shock.
- Do not operate any switch with wet hands.  
Doing so may cause an electric shock.
- Do not touch the DB unit while the power is ON, even if the DB unit is in the idle state.  
Doing so may cause an electric shock.

## **CAUTION** [Operation]

- The DB unit radiating fin, the radiating resistors and Dynamic brake resistors are hot. Do not touch them.  
Failure to follow this warning may cause burns.

## **DANGER** [Maintenance, inspection and parts replacement]

- Always turn the power OFF before inspecting the DB unit and passing of 10 minutes or more from confirmation of stop of motor. Also check DC voltage between P to N and confirm that it is less than 30V.  
Failure to do so may cause an electric shock, personal injury or fire.
- Unauthorized persons shall not perform maintenance, inspection or parts replacement.  
Use insulated tools for maintenance and inspection.  
Failure to do so may cause electric shock or personal injury.

## **DANGER** [Other]

- Never modify the unit.  
Doing so may cause electric shock or personal injury.

## **CAUTION** [General precautions]

Some illustrations given in this manual show the in DB unit from which the option cover or safety shields have been removed to illustrate the details. Before operating, reinstall these covers and shields to their original positions and the DB unit according to this manual.  
These safety precautions and specifications stated in this manual are subject to change without notice.

# Table of contents

<b>PLEASE READ BEFORE USE .....</b>	<b>2</b>
FOR SAFETY .....	2
<b>CHAPTER 1 FUNCTIONAL OUTLINE .....</b>	<b>6</b>
1.1 OPERATION PRINCIPLE .....	6
<b>CHAPTER 2 BASIC SPECIFICATION.....</b>	<b>8</b>
2.1 COMMON SPECIFICATION .....	8
2.2 UNIT SPECIFICATION.....	8
<b>CHAPTER 3 INSTALLATION AND WIRING.....</b>	<b>9</b>
3.1 INSTALLATION.....	9
3.2 CONNECTION.....	10
3.3 TERMINAL SPECIFICATIONS.....	13
<b>CHAPTER 4 OUTLINE DIMENSION.....</b>	<b>14</b>
<b>CHAPTER 5 OPERATION.....</b>	<b>15</b>
5.1 EXPLANATION OF OPERATION .....	15
5.1.1 VFDB2009-Z printed circuit board .....	15
5.1.2 Display.....	17
5.1.3 Operation method of a display for indication.....	17
5.2 SET-UP BEFORE OPERATION .....	19
5.2.2 Set-up of single operation or Master/Slave system parallel operation .....	21
5.3 DYNAMIC BRAKE OPERATION.....	22
5.4 SET-UP ITEMS .....	23
5.4.1 List of set-up items .....	23
5.4.2 F10 (Setting mode of DB operation voltage) .....	23
5.4.3 F20 (Power supply voltage selection · Master / Slave selection · Station number set-up mode) .....	24
5.4.4 F30 (The display gain / offset automatic adjustment mode of D.C. voltage) .....	26
5.4.5 F40 (The display gain / offset hand adjustment mode of D.C. voltage) .....	27
<b>CHAPTER 6 SELECTION OF PERIPHERAL DEVICE .....</b>	<b>29</b>
6.1 RESTRICTION IN DB OPERATION .....	29
6.1.1 DB operating time and a quiescent period.....	29
6.1.2 Current value which the transistor built in DBunit permits.....	29
6.2 SELECTION OF BRAKING RESISTOR .....	30
6.3 SELECTION OF THERMAL RELAY .....	33
6.4 EXAMPLE OF PERIPHERAL EQUIPMENT SELECTION .....	33
<b>CHAPTER 7 OPTION .....</b>	<b>34</b>

7.1	COMMUNICATION OPTION BOARD [DBIF2009-Z PC BOARD]	34
7.1.1	Extension of the function by applying of a communication option PC board	34
7.1.2	Communication option DBIF2009-Z PC board	35
7.1.3	Attachment of a communication option board, connection of a connector	36
7.1.4	Connection of a telecommunication cable and a setup of a terminator switch	38
7.1.5	Station number set-up	43
7.1.6	Main circuit wiring at the time of communication option PC board attachment	43
7.1.7	Set-up of the inverter at the time of communication option PC board use	45
7.2	OPTION COVER	45
<b>CHAPTER 8 REPLACEMENT WITH THE OLD MODEL DB UNIT</b>		<b>46</b>
8.1	REPLACEMENT WITH VFDB2002 SERIES	46
8.2	REPLACEMENT WITH VFDB5022, VFDB5044, VFDB91-200	46
8.3	PARALLEL OPERATON METHOD WITH VFDB SERIES	47
8.3.1	Setup of VFDB2009 series	47
8.3.2	Connection	47
<b>CHAPTER 9 TROUBLE SHOOTING</b>		<b>49</b>
9.1	PROTECT DISPLAY	49
9.2	TROUBLE SHOOTING	49
9.3	RESET	50
9.4	PROTECTION OAT THE TIME OF COMMUNICATION OPTION USE	51
<b>CHAPTER 10 MAINTENANCE</b>		<b>52</b>
10.1	REGULAR CHECK	52
10.2	DISPOSAL	52

# Chapter 1 Functional outline

VFDB2009 series dynamic brake system is equipment (DB unit) which controls the regeneration energy for acquiring brake power. In order to acquire brake power other than DB unit, the braking resistor (DBR) which consumes regeneration energy as heat, and the protection thermal relay (OCRY) which carries out electrical overload detection are required.

The brake power gained due to the loss (a total of about 10 to 15%) by inside the inverter and inside the motor because the inverter unit doesn't have the ability to process the suppression energy. When making the continuous regeneration energy under operation, or the big regeneration energy in a sudden slowdown consume by resistance and acquiring brake power, VFDB2009 series dynamic brake system is used.

VFDB2009 series dynamic brake system has compatibility in VFDB2002 series dynamic brake system, attachment, and an operating method. The VFDB2002 series dynamic brake system applied to the present system is exchanged for a VFDB2009 series dynamic brake system, and a simple substance and operation to mix are possible.

VFDB2009 dynamic brake system is designed so that the content of a lead, mercury, cadmium, sexavalent chrome, PBB, and PBDE may be based on the RoHS instructions which EU defines in consideration of the influence on environment.

## 1.1 Operation principle

The suppression energy returns to the inverter unit when motor becomes the regeneration mode. The DC voltage of inverter rises, because the inverter doesn't provide the regenerative function to the power supply. The DB unit detects this DC voltage, operates the switching element (IGBT) in the unit, and consumes the regenerative energy to resistor (DBR) for power generation. If the regenerative mode became finish, DC voltage returns to a normal value, switching element (IGBT) becomes an immovable work.

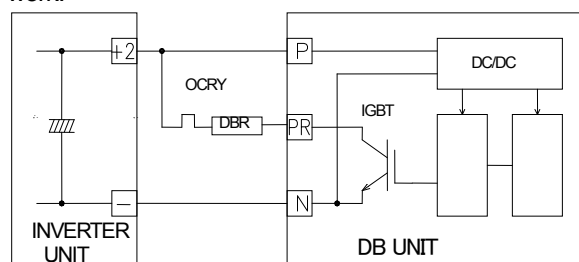

Figure 1-1 basic circuit

\* Regenerative mode \*

The case where the torque has been put out the motor to the machine's called powering mode in the place where the machine is driven with inverter. The motor rotation frequency rises more than the output frequency of the inverter, it enters the state to have returned the torque from the machine to the motor under such a condition when the sudden deceleration or a big load of  $GD^2$  is naturally decelerated from this state for instance, this is called the regentive mode.

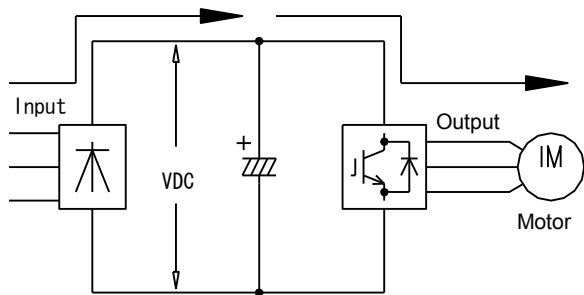

Fig1-2 Power flow of powering mode

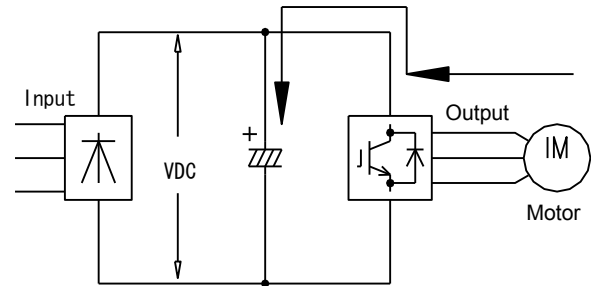

Fig 1-3 Power flow of regenerative mode

**⚠ CAUTION [Safety precautions]**

Carefully read the instruction manual before use, and use the inverter correctly.

Our VFDB2009 series dynamic brake system are not designed or manufactured for the purpose of use in life-support machines or systems.

If you intend to use the product stated in this document for special purposes, such as passenger cars, medical devices, aerospace devices, nuclear energy controls and submarine relaying machines or systems, consult our sales department.

This product is manufactured under strict quality control. However, if it is used in critical equipment in which VFDB2009 series dynamic brake system failure may result in death or serious damage, provide safeguard to avoid serious accidents.

To use this product, electrical work is necessary. The electrical work must be done by qualified expert.



# Chapter 2 Basic Specification

## 2.1 Common specification

The common specification of VFDB2009 series dynamic brake system (VFDB2009 series DB unit) are shown in the following table.

Table 2.1 Common specification

DB operation voltage (Adjustment)	[200V series]DC300V~400V±3% [400V series]DC600V~800V±3%	
Parallel operation	Master · Slave system	
Maximum parallel number	Six sets	
Protection function	Abnormalities of a main circuit, Fan overheat, Abnormalities of a preset value, 200V series over voltage	
Correspondence standard	RoHS instruction conformity	
Environmental condition	Temperature of operation	0~50°C
	Preservation temperature	-20~60°C
	Humidity	20~90% (Not condensation)
	Altitude	1000m or less
	Atmosphere	No poisonous gas, metal powder, and oil and fat etc.
Protection structure	IP00 (JIS C 0920, EN/IEC60529) Structure of an open type where the protection to a human body, the protection to invasion of a solid object, and the protection to invasion of water are not taken into consideration in particular.	

## 2.2 Unit specification

The specification of each VFDB2009 series DB unit is shown in the following table.

Table 2.2 DB unit specification

Type		VFDB2009-50	VFDB2009-200N	VFDB2009-200F
Rated current	Peak current (※1)	50[A] (1[min])	200A[A] (1[min])	200[A] (1[min])
	Continuous current	12[A]	58[A]	120[A]
Cooling system		Air cooling without blower	Air cooling without blower	Air cooling

※1:DB usage rate =10[%]

# Chapter 3 Installation and Wiring

## 3.1 Installation

### ① Installation location of unit

The conditions in the installation location affect the life and the reliability of the inverter. Avoid using it in the following places.

- (1) If the DB unit is installed in a highly humid or dusty place, or in a place exposed to water or oil, the circuit insulation will be deteriorated, and the life of the parts will be shortened.
- (2) If the working ambient temperature is too high, the life of the capacitor and cooling fan motor will be shortened.
- (3) In a place with corrosive gas, connector contact failure, breaking of electric wires and damage of parts may be caused.
- (4) In a place with heavy vibration, connector contact failure, breaking of electric wires and damage of parts may be caused.
- (5) If the DB unit is used at an ambient temperature of 0°C or less, use a heater to increase the temperature to more than 0°C at the start of the DB unit. After the DB unit starts, it generates heat by itself to more than 0°C and will operate normally.

### ② Installing the unit

To use dynamic brake unit installed in a control panel, install as follows.

## DANGER [Mounting]

- Improper installation may cause an electric shock or a fire.

#### (1) Installation direction

VFDB2009 DB unit turns a main circuit terminal down and attaches it perpendicularly. If installed horizontally, it will not be ventilated sufficiently and will be overheated. Enough consideration must be taken to the routes of suction and exhaust of air.

Moreover, the cooling fan of DB unit (VFDB2009-200F) with a cooling fan inhales from the bottom, and exhausts air to the top. Keep sufficient space above the unit so that ventilation is not prevented by wiring dusts, etc.

When installing VFDB2009 DB unit, keep cooling spaces as shown in the following figure 3.1.

When VFDB2009 DB unit is installed in a control panel, ventilate the panel to keep the temperature in the panel within 50°C. (If the ambient temperature is high, the reliability of the inverter will be degraded.)

#### (2) Cautions

- Surely exhaust the heat generated by the DB unit to the outside of the panel. Prevent the exhaust from the DB unit to circulate in the panel.
- Install the resistor on the outside of the panel as much as possible.
- Avoid using the DB unit in a considerably coarse environment.

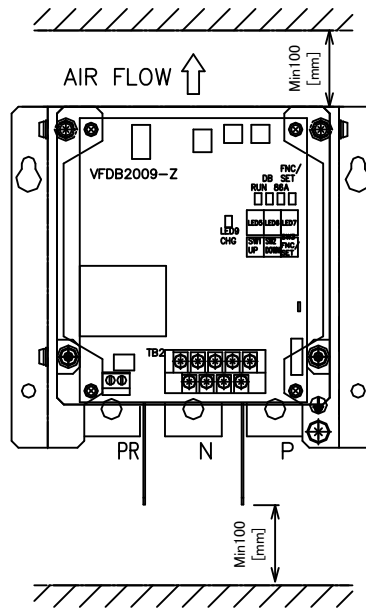

Figure 3.1 DB unit cooling space

## 3.2 Connection

A maximum of six sets of parallel runs are possible for VFDB2009 series dynamic brake system. Please keep in mind that control wiring differs in single operation and parallel operation. Moreover, it is necessary to change a setup of DB unit in accordance with wiring. refer to "5.2.2 Set-up of single operation or Master/Slave system paralle operation" for change of a setup. In addition, a parallel operation with VFDB2002 series is also possible for this VFDB2009 series. Refer to "8.3.2 connection method" for the wiring at the time of a parallel run with VFDB2002 series.

The parallel operation of DB unit of our company has adopted "Master & Slave system." "Master & Slave system" sets to Master DB unit which each DB unit performed DB operation detection and carried out DB operation detection previously, and takes out instructions of ON/OFF of switching device (IGBT) to other parallel units. Figure 3.3 shows the connection method and the wiring between each DB unit becomes the same.

DB unit set up by Master unit performs DB operation detection, and "Master & Slave system" of VFDB2002 series takes out instructions of ON-OFF of switching device (IGBT) of a slave unit. Even when VFDB2009 series DBunit is applied, "Master & Slave system" of VFDB2002 series is possible. Refer to Figure 8.1 for the connection method in that case.

In accordance with the power supply voltage system of an inverter, a DB unit setup is required before use. When DB unit is used by mistaken setup, there is fear of breakage and unusual operation. Refer to "5.2.1. Change of a power supply voltage" and "5.4.3 F20 (Power supply voltage selection and Master/Slave selection and Station number set-up mode) for a setup of a power supply voltage system.



## ○ Notes at the time of wiring

- Lay the main circuit wires and the control signal wires apart from each other.
- Wiring of an inverter should follow the instructions manual of inverter each model.
- Inside of a figure 3 of a part  $\Delta$  of the connection example wires for the twist. Please lay out the equipment to shorten as much as possible and wire for wiring. If the twist line is not used, the surge voltage is by the twice or more. there is a possibility of damaging the unit.
- Please connect input power source (P,N) of DB unit from the middle D.C. power (+2,-) of the Inverter unit by twist cable. Refer to Table 3-1 for the size of the use cable and number of time to twist .
- Change the connector on DB unit according to the voltage system of an inverter. Refer to "5.2.1 Change of power supply voltage" for details.
- Wire the DB unit for the interlock relay use doing that operates by the INV RUN signal contact (52MAX) of the inverter so that the DB unit should not work while the inverter is stopping and wire use twist cable. The interlock relay must use the lpower relay.
- Select braking resistor (DBR) so that required regeneration power is obtained, and take protection coordination in thermal relay (OCRY). It becomes a cause of a fire when cooperation cannot be taken. About selection of braking resistor (DBR) and thermal relay (OCRY), refer to "6.2 Selection of braking resistor" and "6.3 Selection of thermal relay." Thermal relay (OCRY) should use what operates with direct-current current.
- Please shorten wiring to braking resistor (DBR) and thermal relay (OCRY) as much as possible, and twist it, and the wiring near braking resistor (DBR) should perform heat-resistant processing.
- Since braking resistor (DBR) generates heat (200 degrees or more), it is installed in a place with sufficient ventilation, and does not put combustibles on the surroundings.
- By operation of thermal relay (OCRY), the trip of circuit braker (MCCB) or electromagnetic contactor (MC) by on the inverter input is carried out.
- Protection contact(86A) of the DB unit operates by protection of DBunit. Please connect the protection contact (86A) of the DB unit to the circuit of inverter operation instructions in series as an interlock of inverter operation.
- Main circuit wiring of an inverter and DB unit should set to a maximum of 10m, and please wire as short as possible.
- Please be sure to connect the ground of a DB unit.
- When you use DB unit by a parallel operation, please be sure to connect master instructions signal (DB-IN) and a slave input signal (DB-ON).

Table 3.1 Main circuit used cable (DB usage rate 10%ED)

Main current[A]	Wiring size[mm <sup>2</sup> ]	Number of times to twist[turn/m]
200	38	5
160	22	7
110	14	8
80	8	10
50	8	10
40	5.5	10
30	3.5	10
18	2	10

※ Table 3.1 is the wire size at the time of adopting the fire-resistant poly flex time electric wire.

( Example:MLFC[Hitachi Cable])

※ Twist a wire equally so that the length of each wire becomes the same.

### 3.3 Terminal specifications

Table 3.2 List of terminal specification

Device	Terminal number	Use	Description
Main circuit	P	DC voltage input (+ side) For DBR connection For thermal relay (OCRY) connection	Connect the inverter-middle D.C. voltage(⊕) Connect a braking resistor Connect the thermal relay(OCRY)
	PR	For DBR connection	Connect a braking resistor
	N	DC voltage input (- side) For thermal relay (OCRY) connection	Connect the inverter-middle D.C. voltage (⊖) Connect the thermal relay(OCRY)
	⊕	Earth	Connect the ground
VFDB 2009-Z terminal block TB2	DB-IN	Slave input	DB operation will be started if a signal is inputted during DB operation permission.
	DB-ON	master instructions	A signal is outputted when the inverter-middle D.C. voltage exceeds DB operation starting potential (F10).
	86A	Protection contact	DB unit turns on during the protection mode. (86A : AC230V 0.5A)
	52MA	Operation contact	It will be in the state in which DB operation is possible by ON.

# Chapter 4 Outline dimension

## ○ VFDB2009-50

Terminal marking	Terminal screws
PR,N,P, ⊕	M4
VFDB2009-Z TB2	M3

Color	Mansel 5Y7/1
Weight	1.2kg

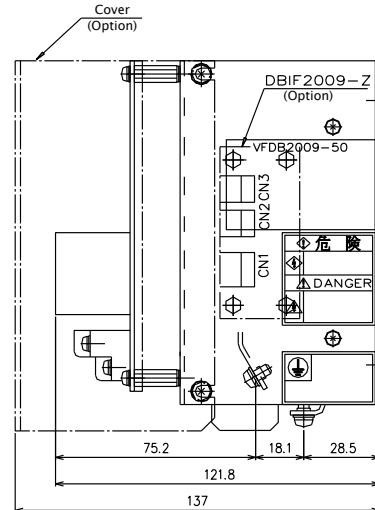
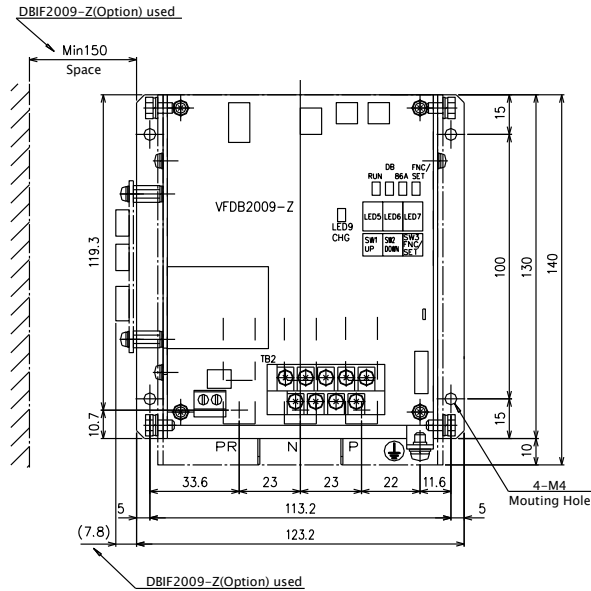

## ○ VFDB2009-200N

### VFDB2009-200F

Terminal marking	Terminal screws
PR,N,P	M8
⊕	M5
VFDB2009-Z TB2	M3

Color	Mansel 5Y7/1
Weight	4kg

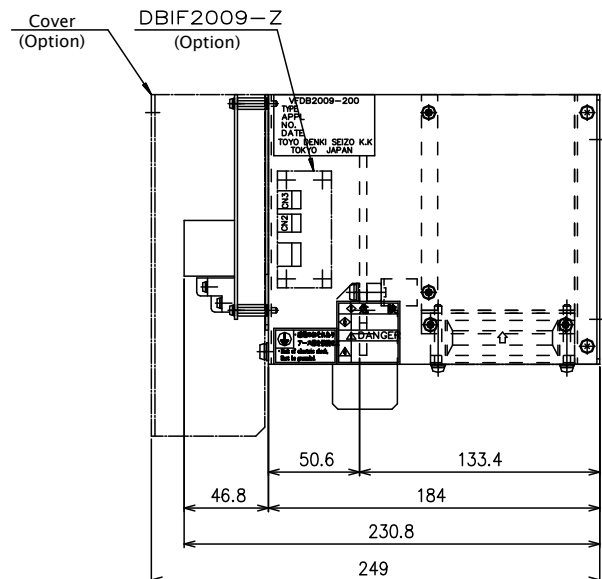
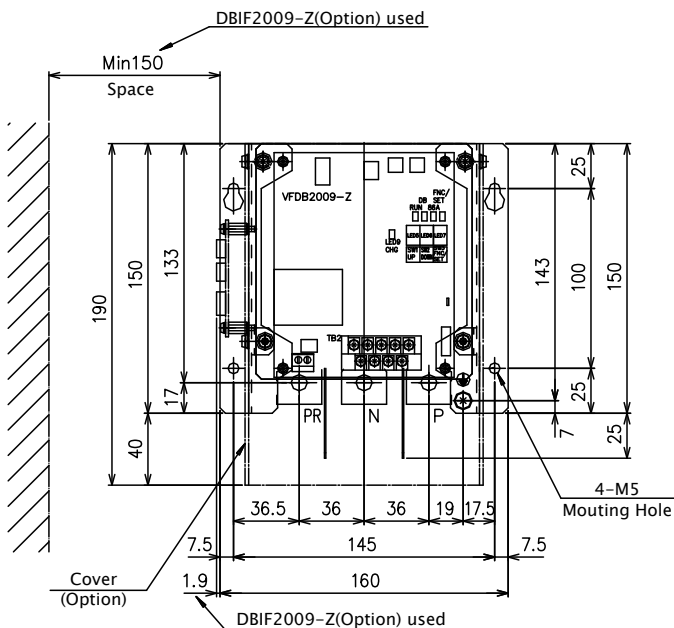

# Chapter 5 Operation

VFDB2009 series Dynamic brake unit operates in the power supply of the middle D.C. voltage of the inverter. The DB unit becomes a waiting state if the inverter run signal(52MA) is input after the inverter-middle D.C. voltage rises, and LED "RUN" (Light Emitting Diode) lights. Main switching device(IGBT) operates when the middle D.C. voltage rises by the regeneration of the inverter, and it rises up to the voltage set to the DB operating point,and LED "DB" lights. At this time, brake resistor connected to DB unit consumes regeneration energy, and if inverter-middle D.C. voltage turns into below the voltage that stops DB operation, a switching device is turned off.

## 5.1 Explanation of operation

### 5.1.1 VFDB2009-Z printed circuit board

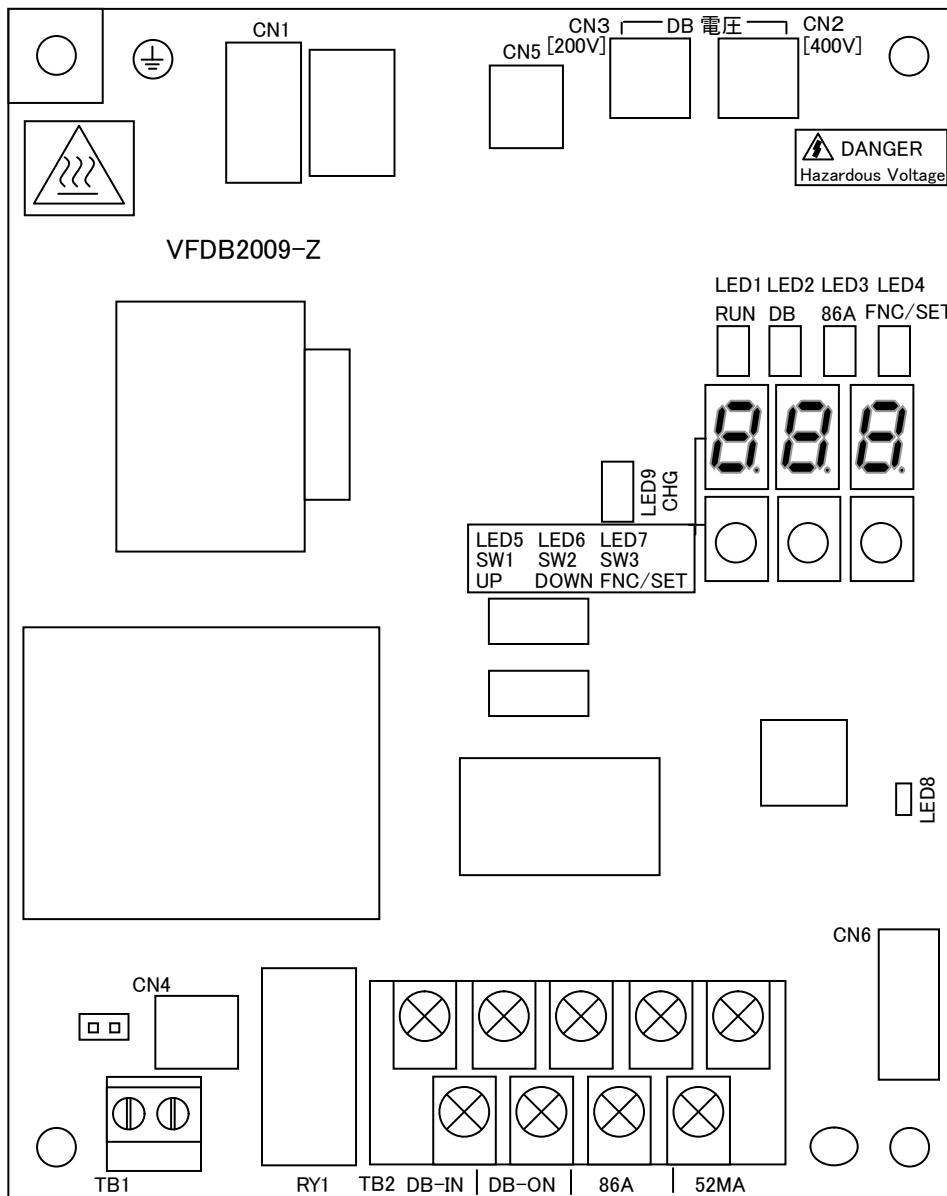

Figure 5.1 VFDB2009-Z printed circuit board



Table 5.1 List of parts use and functions on the VFDB2009-Z printed cuicuit board

Name (※5)	Parts use and functions
CN2 CN3	The connector for a change of a power supply voltage system
CN6	The connector for connection with communication option DBIF2009-Z PC board (※1)
LED8	LED for a normal operation check of CPU (※2)
LED9	CHG lamp (※3)
TB2	The terminal block for DB unit control (※4)

※1: Refer to "7.1 communication option DBIF2009-Z PC board" for a communication option board.

※2: LED8 blinks in a cycle of about 2 seconds, while the VFDB2009-Z board is operating normally. While not blinking, failure of the loose connection of CN1 or a VFDB2009-Z board can be considered.

※3: The middle D.C. voltage of an inverter turns on LED9 by 30V or more. When the light is not switched on, failure of the loose connection of CN1 or a VFDB2009-Z board can be considered.

※4: Refer to "3.3 Terminal specifications" for the function of TB2.

※5: Refer to "5.1.2 Display" for LED 1-7 and SW 1-3.

 **DANGER** [VFDB2009-Z PC board]

- DB unit cannot be recklessly touched during CHG LED lighting.  
Failure to do so may cause electric shock.
- Wiring of TB1,CN1,CN4,CN5 are not changed.  
Failure to do so may cause electric shock or personal injury and part breakage

## 5.1.2 Display

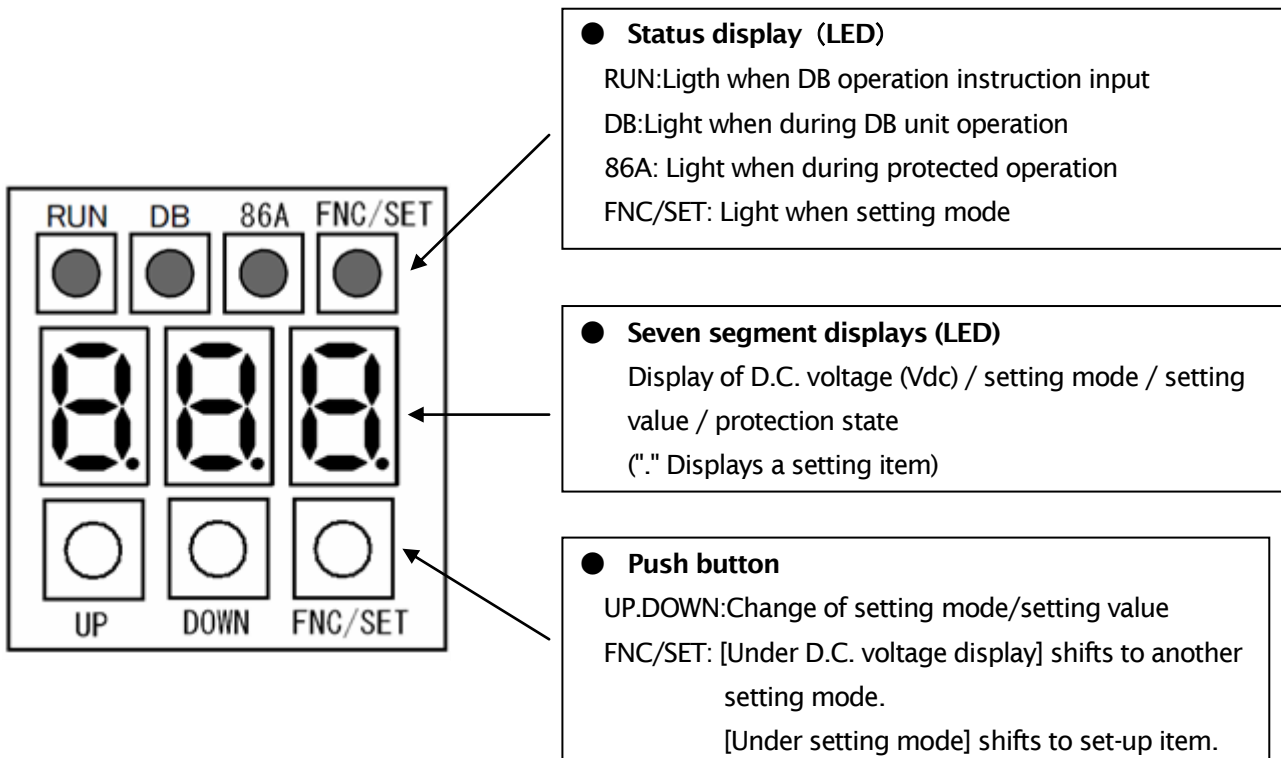

Figure 5.2 Display for indication VFDB2009-Z PC board

## **DANGER** [Operation]

- Do not operate any switch with wet hands.  
 Doing so may expose you to shock hazard.

### 5.1.3 Operation method of a display for indication

If the power supply of an inverter is turned on, the inverter-middle D.C. voltage will rise and D.C. voltage will be displayed on the display for indication of DB unit. Setup and adjustment of DB unit are possible by operating a display for indication.

It changes from the display mode of D.C. voltage to a setup and adjustment of DB unit to setting mode. The mode can be changed by pushing "FNC/SET" and "UP", and the "DOWN" button.

※ "△" in a figure expresses the "UP" button, and "▽" expresses the "DOWN" button.

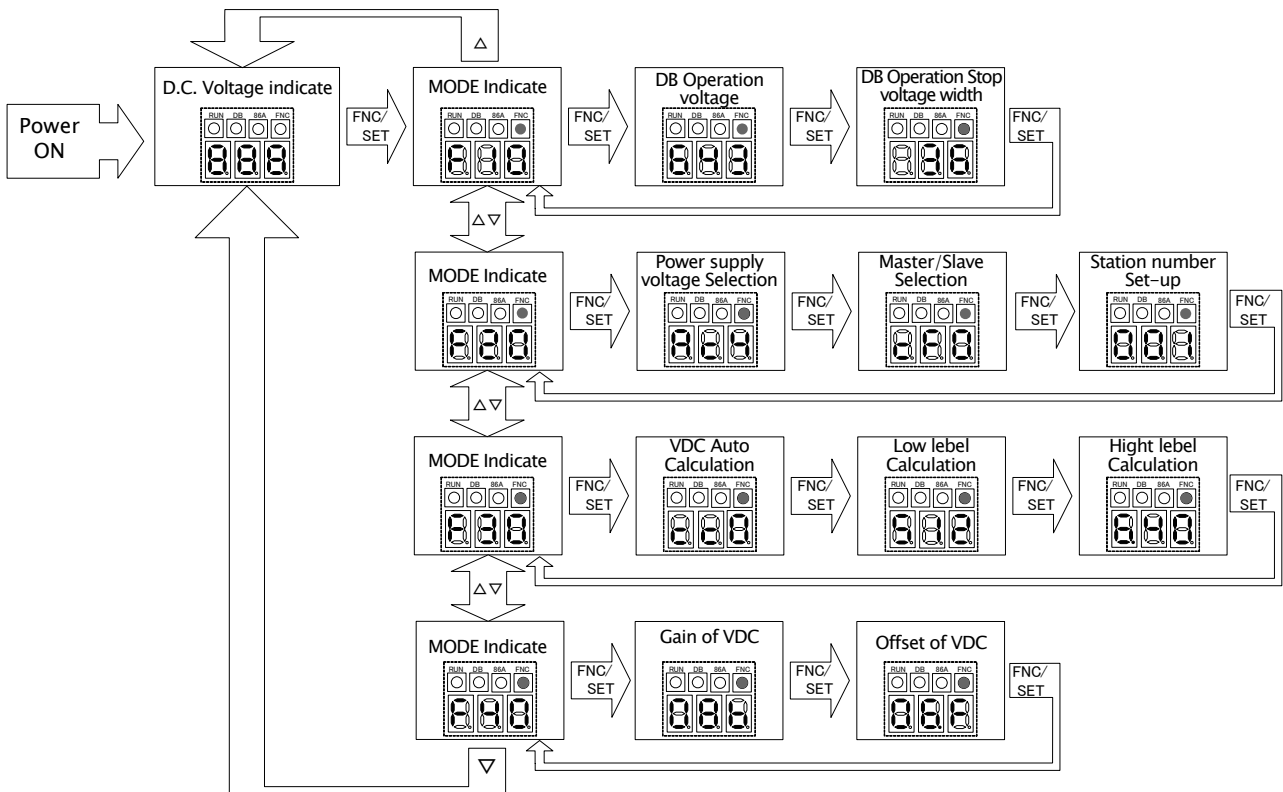

Figure 5.3 The mode change state of a display for indication

If the "FNC/SET" button is pushed during the display of direct-current voltage, it will shift to setting mode "F10" and LED "FNC/SET" will light up simultaneously. If "UP" or the "DOWN" button is pushed into setting mode, it will shift to setting mode (F10-F40), and if the "FNC/SET" button is pushed, it will shift to the setting item in each setting mode.

※ If LED "RUN" lights up in set-up mode (DB operation instruction ON), it will switch to D.C. voltage display mode compulsorily. Moreover, even if it pushes the "FNC/SET" button during lighting of LED "RUN", it does not switch to setting mode.

Table 5.2 Set-up mode list

Setup mode	Description
F10	DB operation voltage setting mode
F20	Power supply voltage selection and Master/Slave selection and Station number set-up mode
F30	The display gain / offset automatic adjustment mode of D.C. voltage
F40	The display gain / offset hand adjustment mode of D.C. voltage

※ Refer to "5.4 Set-up items" for the details in each set-up mode.

## 5.2 Set-up before operation

Please be sure to perform the following setup before using DB unit. DB unit is common use in the power supply voltage (200V series /400V series) of inverter and single/parallel operation. Since power supply voltage is set as 400V series and the mode of operation is set as single operation at the time of shipment, a setup is changed according to application.

### 5.2.1 Change of a power supply voltage

- ① **Before turning on the power supply of an inverter**, please switch connector CN2 and CN3 of VFDB2009-Z PC board, according to the power supply voltage of the inverter to be used.

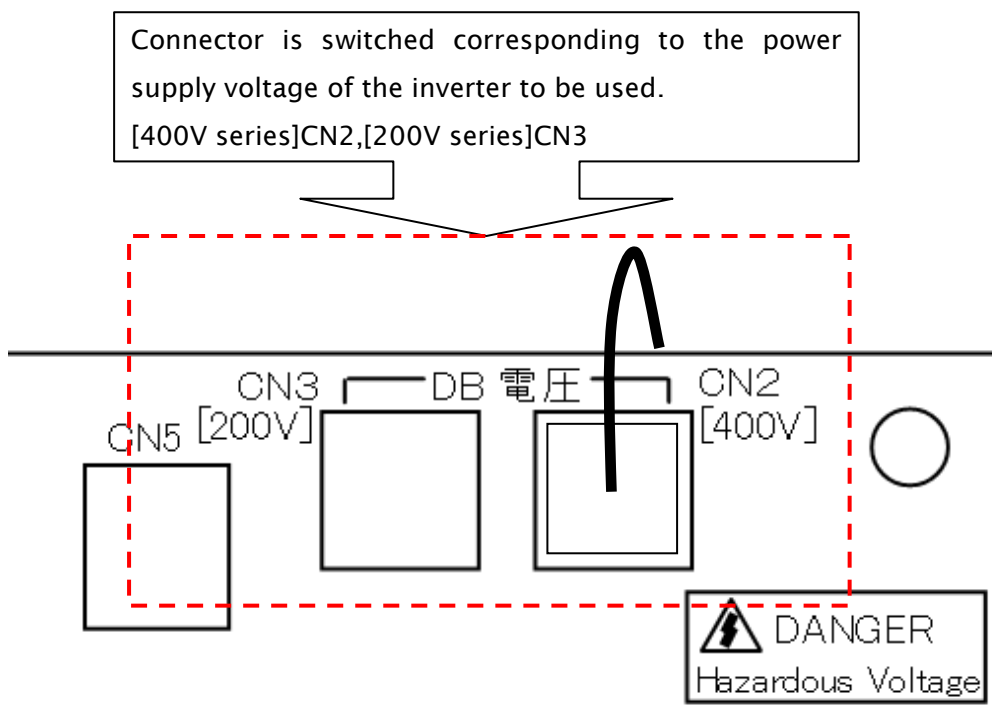
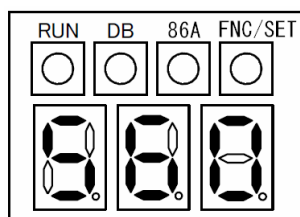

Figure 5.4 Power supply voltage change connector

## **DANGER** [Connector]

- Before turning on the power supply of an inverter, the position of a power supply voltage system change connector is checked.  
Failure to do so may cause part breakage.

- ② **After checking that operation instructions (52MA) are not contained**, the power supply of an inverter is turned on. DB unit is switched to “F20” (Power supply voltage selection and Master/Slave selection and Station number set-up mode), and set-up of power supply voltage is performed.



If the power supply of an inverter is turned ON, D.C. voltage will be displayed on the display for indication of DB unit. Check that LED"RUN" is not on and push the "FNC/SET" button.

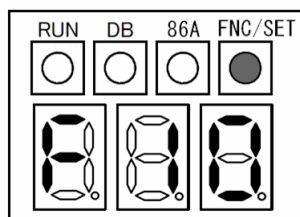
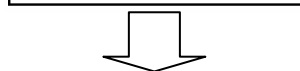

LED" FNC/SET" lights up and "F10" setting mode is displayed. "UP" button is pushed once and changed into "F20" setting mode.

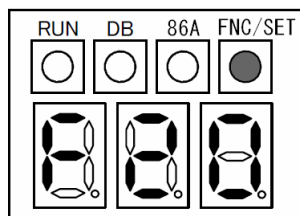
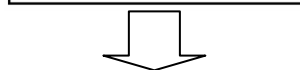

"F20" set-up mode is displayed. "FNC/SET" button is pushed once and it switches to set-up item "Power supply voltage selection."

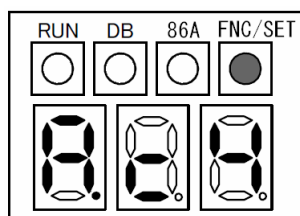
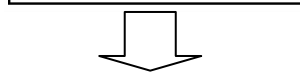

Set-up item "Power supply voltage selection" is displayed. ( "." is displayed on seven segments of the triple figures.) Change a set-up according to the power supply voltage series of the inverter to be used. Change of a set-up is made with "UP" or the "DOWN" button.

[400V series] Ac4, [200V series] Ac2

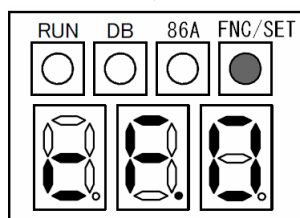
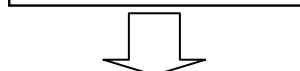

Please be sure to push the "FNC/SET" button after a set-up. Change of a set-up does not become effective.

Another set-up item is displayed.

Set-up of a power supply voltage series is completion above.

- ※ Refer to "5.4.3 F20 (Power supply voltage selection and Master/Slave selection and Station number set-up mode) for the details of a setting item.

## **DANGER** [Turn on power supply]

- Before turning on the power supply of an inverter, it checks that there is no input in operation instructions (52MA). Failure to do so may cause malfunction, part breakage or fire.

### 5.2.2 Set-up of single operation or Master/Slave system parallel operation

Perform the following setup according to single operation and a parallel operation. In addition, since wiring differs by single operation and a parallel operation, please perform the right wiring for "3.2 Connection" to reference.

Ⓞ **After checking that operation instructions (52MA) are not contained**, the power supply of an inverter is turned on. DB unit is switched to "F20" (Power supply voltage selection and Master/Slave selection and Station number set-up mode), and set-up of single operation or Master/Slave system parallel operation is performed.

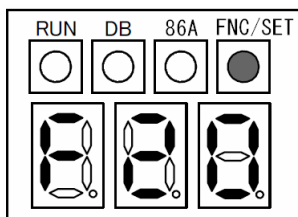
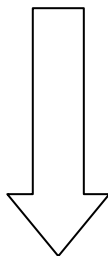
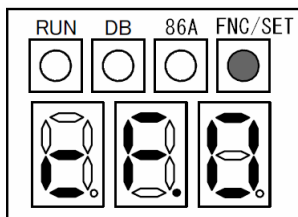
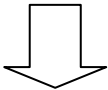
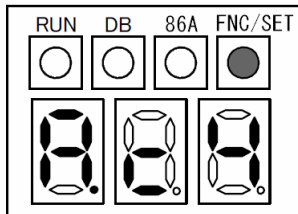

Set-up item "power supply voltage selection" of "F20" set-up mode is displayed by the same operation as "5.2.1 Change of power supply voltage." "FNC/SET" button is pushed once and it switches to set-up item "Master/Slave selection."

Set-up item " Master/Slave selection " is displayed. ( "." is displayed on seven segments of the double figures.) Change a setup to compensate for single operation or a parallel operation. Change of a set-up is made with "UP" or the "DOWN" button.

Table 5.3 Master/Slave set-up

Operation mode		Setting value
Single operation		cF0
Parallel operation		cF0
Paralle operation with VFDB2002 series (※)	Master unit	cF0
	Slave unit	Cf1

※ Make Master unit into one set and set other parallel units as Slave unit.

Please be sure to push the "FNC/SET" button after a set-up. Change of a set-up does not become effective.

"F20" set-up mode is displayed.

Setup of a Master / Slave selection is completion above.

※ Refer to "5.4.3 F20 (Power supply voltage selection and Master/Slave selection and Station number set-up mode) for the details of a setting item.

### 5.3 Dynamic Brake operation

If a motor is suddenly decelerated with an inverter, it will become regeneration mode and the inverter-middle D.C. voltage will rise. When the inverter-middle D.C. voltage exceeds set-up starting voltage of DB operation at this time, DB unit performs Dynamic brake operation. Flow to DB operation is shown in the following figure 5.5.

In addition, starting voltage of DB operation and voltage width which stops DB operation of a statement all over a figure, It sets up by "F10" (DB operation voltage setting mode).

Refer to "5.1.2 Display" for the conditions which various kinds of LED turns on.

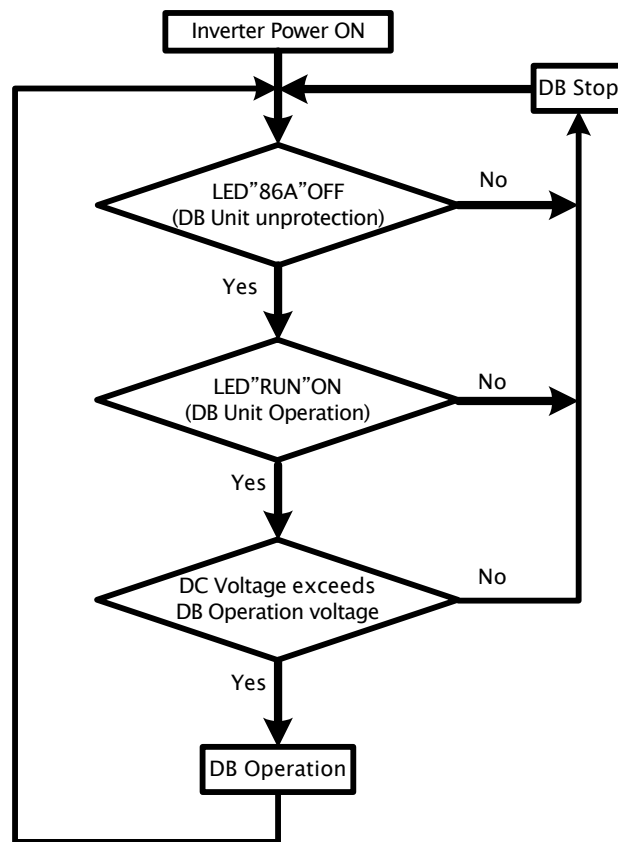

Figure 5.5 Flow chart of DB operation

## 5.4 Set-up items

### 5.4.1 List of set-up items

Table 5.4 List of set-up items

Setting mode	No.	Set-up items	Set-up range	Initial value	unit
F10(※1)	1	Starting voltage of DB operation	(200V series) 300~400 (400V series) 600~800	(200V series) 360 (400V series) 720	V
	2	Voltage width which stops DB operation	(200V series) 5~50 (400V series) 10~100	(200V series) 18 (400V series) 36	V
F20	1	Power supply voltage selection	Ac2:200V series Ac4:400V series	Ac4	—
	2	Master/Slave selection	cF0:single/Master cF1:Slave	cF0	—
	3	Station number set-up	1~7	1	—
F30(※4)	1	Automatic calculation of Vdc is possible.	cc0: Automatic calculation stop cc1: Automatic calculation start	cc0	—
	2	Vdc automatic calculation (Low level)	—	—	—
	3	Vdc automatic calculation (High level)	—	—	—
F40(※2)	1	Gain of a Vdc display	00~FF	8b(※3)	—
	2	Offset of a Vdc display	00~FF	6F(※3)	—

※1: The preset value of F10 changes with the power supply voltage systems set up by "F20 No.1:power supply voltage selection."

※2: The preset value of F40 is displayed by a hexadecimal number.

※3: Since the preset value of F40 is adjusted at the time of shipment, a preset value may differ from an initial value.

※4: The display gain /offset automatic adjustment mode of D.C. voltage is possible only at 400V series.

### 5.4.2 F10 (Setting mode of DB operation voltage)

Set-up about DB operation voltage is performed in F10 setting mode. Change the preset value in F10 setting mode after setting up "Power supply voltage selection" in F20 setting mode. Refer to "F20" (Power supply voltage selection and Master/Slave selection and Station number set-up mode) for setting mode.

Table 5.5 F10 set-up items

No.	Set-up items	Set-up range	Initial value	unit
1	Starting voltage of DB operation	(200V series) 300~400 (400V series) 600~800	(200V series) 360 (400V series) 720	V
2	Voltage width which stops DB operation	(200V series) 5~50 (400V series) 10~100	(200V series) 18 (400V series) 36	V

※The preset value of F10 changes with the power supply voltage systems set up by "F20 No.1:power supply voltage selection."

#### ○ Starting voltage of DB operation

It is a parameter about DB operation start.

When D.C. voltage exceeds the preset value of the starting potential of DB of operation, DB unit starts DB operation.

Note.1) The starting voltage of DB operation should set up 1.65 or more times of the input power



supply voltage of an inverter.

Note.2) When you use regeneration stall prevention function of an inverter, please give the starting voltage of DB operation, and regeneration stall prevention voltage of an inverter as the same voltage value. Refer to the inverter instructions manual of our company for details.

Note.3) At the time of communication option PC board [DBIF2009-Z] use, DB operation starting voltage preset value of VF66 series inverter is set automatically. Refer to "7.1.1 Extension of the function by applying of a communication option PC board" for details.

○ Voltage width which stops DB operation

It is a parameter about DB operation stop.

After DB operation start, if D.C. voltage falls only DB operation stop voltage width from DB operation starting voltage, DB operation will stop.

$$\text{DB operation stop voltage} = \text{DB operation starting voltage} - \text{DB operation stop voltage width}$$

Ex. When DB operation starting voltage was set as 720V and DB operation stop voltage width is set as 36V DB operation is started when the D.C. voltage of an inverter becomes more than 720V. After DB operation start, when D.C.voltage falls or more 36 V from 720V, DB operation is stopped.

### 5.4.3 F20 (Power supply voltage selection · Master / Slave selection · Station number set-up mode)

In F20 set-up mode, a setup of a power supply voltage series, a setup of single or Master/Slave system, and a setup of station number are performed.

Table 5.6 F20 set-up items

No.	Set-up items	Set-up range	Initial value
1	Power supply voltage selection	Ac2:200V series Ac4:400V series	Ac4
2	Master / Slave selection	cF0:Single/Master cF1:Slave	cF0
3	Station number set-up (※)	1~7	1

※No.3: Station number setup is set up when using communication option [DBIF2009-Z]. When not using DBIF2009-Z, it is not necessary to set up.

○ **Power supply voltage selection**

Set up in accordance with the power supply voltage series of the inverter to be used. Moreover, it is necessary to switch the connector on VFDB2009-Z PC board to compensate for this setup. Refer to "5.2.1 Change of power supply voltage" for details.

○ **Master / Slave selection**

Change a setup according to single or parallel operation of DB unit. In using it by connection of figure 3.3 only in VFDB2009 series, it sets a setup to "cF0." When operating by parallel of the same connection as VFDB2002, or when operating by parallel with VFDB2002 and VFDB2009, one set is made into Master unit and other units are set as Slave unit.

Table 5.7 Master/Slave set-up

Operation mode		Setting value
Single operation		cF0
Parallel operation		cF0
Paralle operation with VFDB2002 series	Master unit	cF0
	Slave unit	Cf1

○ **Station number set-up**

It sets up, when using Communication option board [DBIF2009-Z]. Certainly setting up a station number setup sequentially from 1 and 7 does not set up. Refer to "7.1 Communication option board [DBIF2009-Z]" for a communication option.

When not using DBIF2009-Z, it is not necessary to set up.

### 5.4.4 F30 (The display gain / offset automatic adjustment mode of D.C. voltage)

The display gain /offset of D.C. voltage (Vdc) is adjusted in semiautomatic. (The display gain /offset automatic adjustment mode of D.C. voltage is possible only at 400Vseries.) F30 setting mode is the mode for stopping and starting automatic adjustment. In addition, **in order to adjust automatically, the equipment for carrying out variable of the impressed electromotive force is required.** (Since it is adjusted at the time of shipment, it is not necessary to readjust Display gain /offset of D.C. voltage)

Table 5.6 F30 set-up items

No.	Set-up items	Set-up range	Initial value
1	Automatic calculation of Vdc is possible.	cc0: Automatic calculation stop cc1: Automatic calculation start	cc0
2	Vdc automatic calculation (Low level)	—	—
3	Vdc automatic calculation (High level)	—	—

#### ○ Automatic calculation

The procedure of automatic calculation is shown in the following.

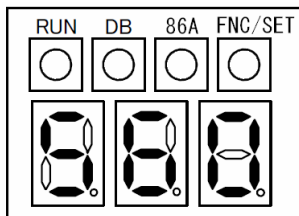

If the power supply of an inverter is turned ON, D.C. voltage will be displayed on the display for indication of DB unit. Check that LED"RUN" is not on and push the "FNC/SET" button.

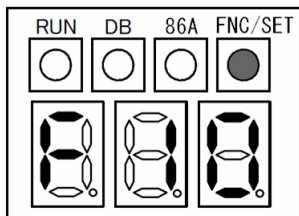
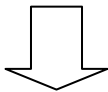

LED"FNC/SET" lights up and "F10" setting mode is displayed. "UP" button is pushed 2 times and changed into "F30" setting mode.

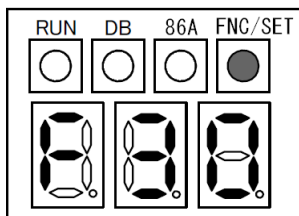
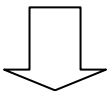

"F30" set-up mode is displayed. "FNC/SET" button is pushed once and it switches to set-up item "Automatic calculation of Vdc is possible."

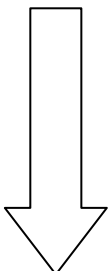

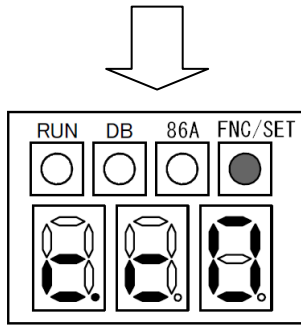

Set-up item " Automatic calculation of Vdc is possible " is displayed. ( "." is displayed on seven segments of the triple figures.) When you adjust display gain /offset of D.C. voltage automatically, please change a setup into "cc1" and push the "FNC/SET" button. Change of a set-up is made with "UP" or the "DOWN" button.

※ When you do not adjust automatically, please set a setup to "cc0", and push the "FNC/SET" button.

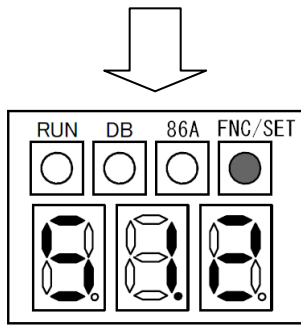

Set-up item "Vdc automatic calculation (Low level)" is displayed. ( "." is displayed on seven segments of the double figures.)

Impress **512(V)** to the D.C. power supply input terminal (P, N) of DB unit, and push the "FNC/SET" button.

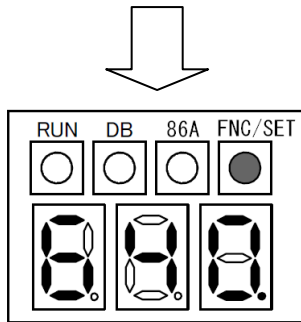

Set-up item "Vdc automatic calculation (High level)" is displayed. ( "." is displayed on seven segments of the single figures.)

Impress **640(V)** to the D.C. power supply input terminal (P, N) of DB unit, and push the "FNC/SET" button.

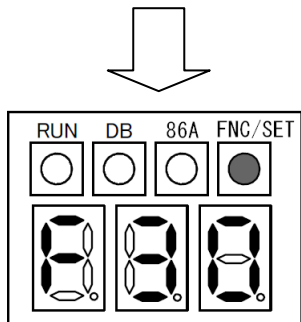

"F30" set-up mode is displayed. Automatic calculation of the D.C. voltage and offset by the above operation is completed, and a gain and offset are adjusted automatically.

#### 5.4.5 F40 (The display gain / offset hand adjustment mode of D.C. voltage)

F40 setting mode adjusts the gain of a D.C. voltage (Vdc) display, and offset manually. (Since it is adjusted at the time of shipment, it is not necessary to readjust Display gain /offset of D.C. voltage)

Table 5.9 F40 set-up items

No.	Set-up items	Set-up range	Initial value
1	Gain of a Vdc display	00~FF	8b(※1)
2	Offset of a Vdc display	00~FF	6F(※1)

※The preset value of F40 is displayed by a hexadecimal number.

※1: Since the preset value of F40 is adjusted at the time of shipment, a preset value may differ from an initial value.

○ **Method of hand adjustment**

The procedure of the adjustment method is shown below.

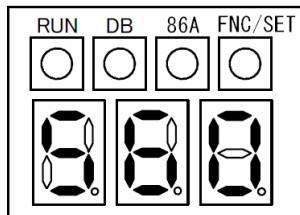

If the power supply of an inverter is turned ON, D.C. voltage will be displayed on the display for indication of DB unit. Check that LED"RUN" is not on and push the "FNC/SET" button.

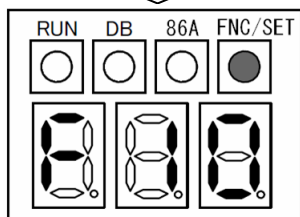

LED"FNC/SET" lights up and "F10" setting mode is displayed. "UP" button is pushed 3 times and changed into "F40" setting mode.

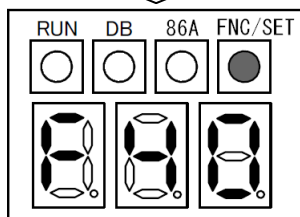

"F40" set-up mode is displayed.

"FNC/SET" button is pushed once and it switches to set-up item "Gain of Vdc display".

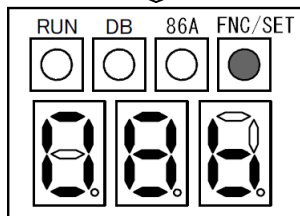

Set-up item " Gain of Vdc display " is displayed.

Push "UP" or the "DOWN" button and adjust a gain. Set up a gain and push the "FNC/SET" button.

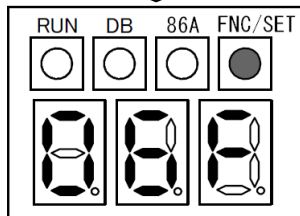

Set-up item " Offset of Vdc display " is displayed.

Push "UP" or the "DOWN" button and adjust a offset. Set up a offset and push the "FNC/SET" button.

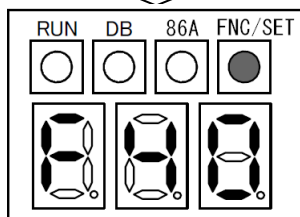

"F40" set-up mode is displayed. The hand adjustment of a D.C. voltage display gain / offset is completion above.

# Chapter 6 Selection of peripheral device

## 6.1 Restriction in DB operation

### 6.1.1 DB operating time and a quiescent period

The DB usage rate is certainly made into less than 10%. Moreover, the current which can be sent through DB unit changes by DB operating time (t).

$$[\text{DB usage rate} = 100 \times T1 / T2(\%)]$$

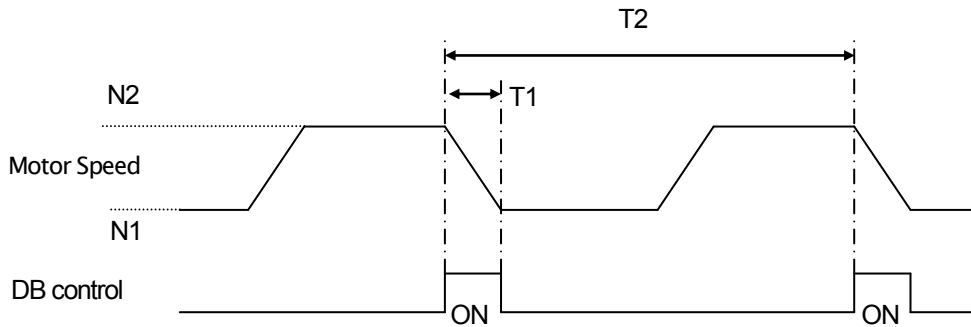

Figure 6.1 DB operating time chart

### 6.1.2 Current value which the transistor built in DBunit permits

At the time of DB operation, please select a braking resistor so that the current exceeding the characteristic of the following table does not flow into a transistor with built-in DB unit.

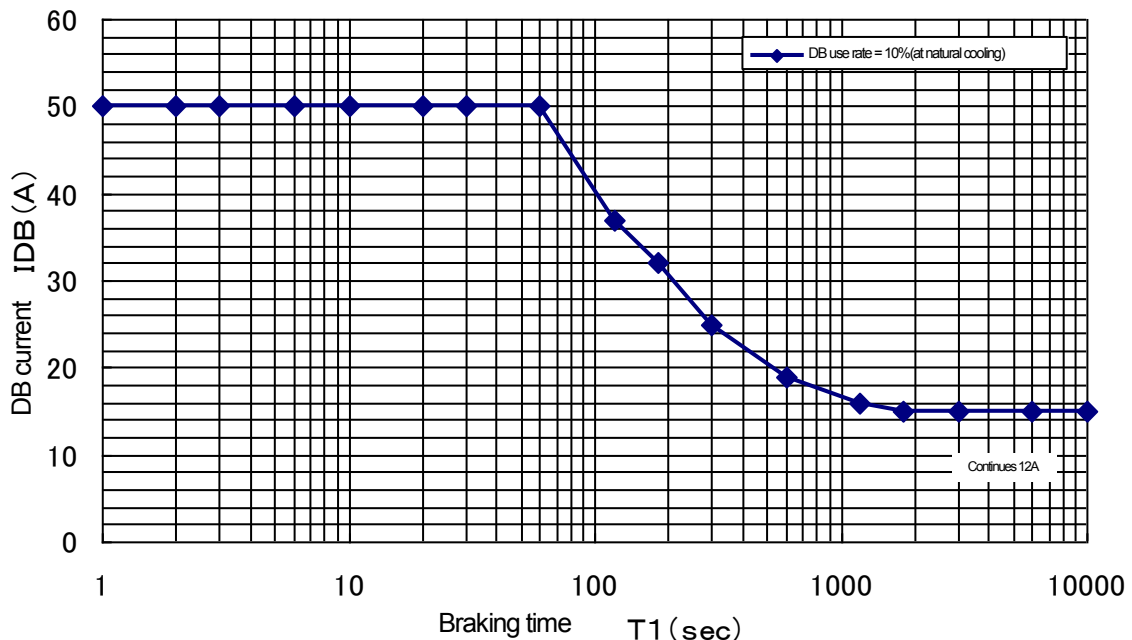

Figure 6.2 VFDB2009-50 Short-time current characteristic

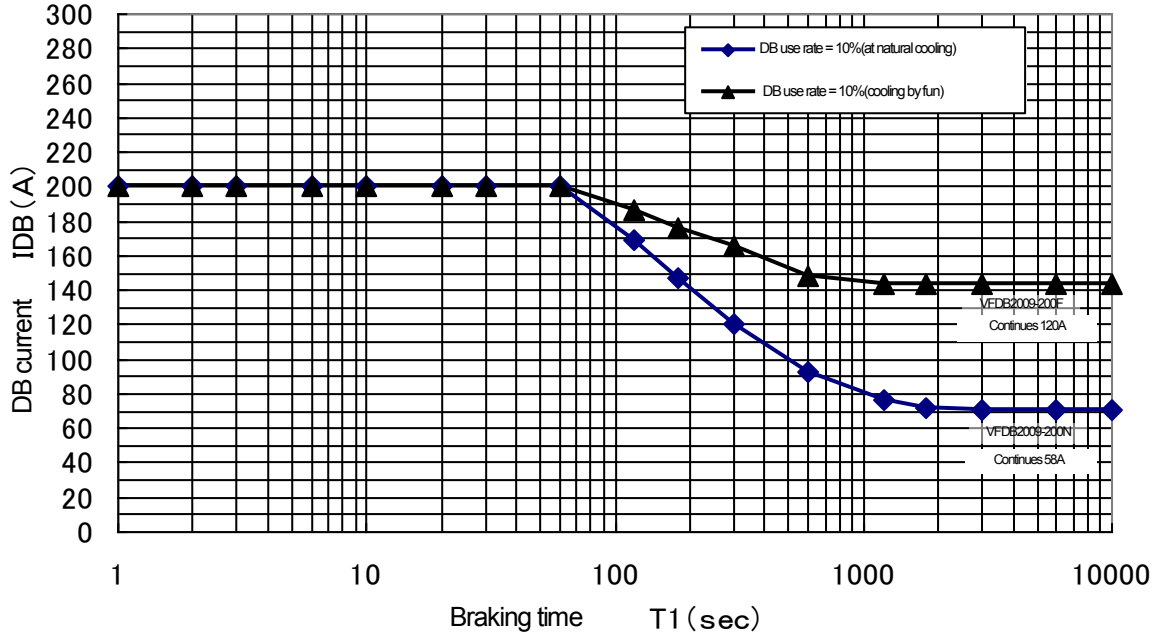

Figure 6.3 VFDB2009-200 Short-time current characteristic

## 6.2 Selection of braking resistor

Braking resistor is selected from the calculation result of the maximum braking power. The maximum braking power shows the maximum regeneration energy which can be processed by current of DB unit and Braking resistor, and required braking power is calculated from load torque and motor speed.

When the braking operation is done with the inverter, it is regenerated to the inverter, the machine energy. When the object of the moment of inertia that rotates with rotational speed  $N_1(\text{min}^{-1})$  decelerates to rotational speed  $N_2(\text{min}^{-1})$  with braking time  $t(\text{sec})$ , the regeneration energy  $E(\text{J})$  and a necessary deceleration Braking torque  $\tau(\text{N}\cdot\text{m})$  are shown by the next expression.

$$\text{Regeneration energy : } E[\text{J}] = \frac{J}{2} \times \left[ \left( \frac{2\pi N_2}{60} \right)^2 - \left( \frac{2\pi N_1}{60} \right)^2 \right] \times \eta_M \quad (1) \quad \text{VFDB2009-200N}$$

$$\text{Braking torque : } \tau[\text{N}\cdot\text{m}] = \frac{2\pi J}{60} \times \frac{N_2 - N_1}{t} \quad (2)$$

$$\text{However, } J[\text{kg}\cdot\text{m}^2] = \frac{GD^2}{4} \quad (3)$$

( $GD^2$ : Flywheel effect ( $\text{kg}\cdot\text{m}^2$ ),  $\eta_M$ : Motor efficiency)

Here, necessary braking torque for inverter  $\tau_B(\text{N}\cdot\text{m})$  subtracts load torque  $\tau_L(\text{N}\cdot\text{m})$  from braking torque  $\tau(\text{N}\cdot\text{m})$  necessary for the deceleration and is shown by the next expression.

$$\tau_B[\text{N}\cdot\text{m}] = \tau - \tau_L = \frac{2\pi J}{60} \times \frac{N_2 - N_1}{t} - \tau_L \quad (4)$$

In addition, maximum regenerative power  $P_B(\text{W})$  becomes the next expression momentarily when beginning to decelerate at this time.

$$P_B[\text{W}] = \frac{2\pi}{60} \times N_2 \times \tau_B \quad (5)$$

Next, braking resistance DBR is selected. To do condition DBR such as the maximum regeneration electric

power at beginning decelerate showing by  $P_B$  can be consumed momentarily, **resistance  $R_{DB} (\Omega)$  is assumed below the value calculated by the next expression.**

$$R_{DB} [\Omega] \leq \frac{(V_{DB})^2}{P_B} \quad (6)$$

( $V_{DB}(V)$ : Operation voltage of DB)

Moreover, average power  $P_{DBR}(W)$  consumed with DBR is calculated by the next expression when the repetition cycle of braking is assumed the  $T(sec)$ , and select the resistance of the rated power that considers the rise in heat of resistance, please.

$$P_{DBR} [W] = \frac{E}{T} \quad (7)$$

Next, the dosis tolerate of the DB transistor is confirmed. When selected DBR is connected, current  $I_{DB}(A)$  that flows to the DB transistor when the DB transistor is on is shown by the next expression.

$$I_{DB} [A] = \frac{V_{DC(MAX)}}{R_{DB}} \quad (8)$$

※ It is assumed  $V_{DC(MAX)}=400V$ (at 200V series) and  $800V$ (at 400V series)

Moreover, the entire effective alternating current  $I_{DB(rms)} (A)$  that the DB transistor considered the period of off are shown by the next expression.

$$I_{DB(rms)} [A] = \frac{V_{DC(MAX)}}{R_{DB}} \times \sqrt{\frac{t}{2T}} \quad (9)$$

It confirms  $I_{DB(rms)}$  is below the D.C. continuous current value and  $I_{DB}$  is below the shown Fig5.2 and fig 5.3 permissible current value of DB unit current indicated by type of DB unit. When not installing on the permissible current value the braking resistance is enlarged, and the current that flows to the DB transistor is made to become below the permissible current value. In this case, the braking torque of the desire is not naturally obtained. Moreover, please correspond by connecting two or more DB units in parallel when you need the braking torque of the desire by all means.

### ◎ Example computation of braking resistor selection

The example of selection of a braking resistor is shown below.

[specification (calculation condition)]

- Input power-supply voltage : AC440V
- Inverter : VF64-2244
- Motor : 22kW( $GD^2=0.57 (kg \cdot m^2)$ ) and motor efficiency  $\eta M=0.845$ )
- Load characteristic :  $GD^2=5.43 (kg \cdot m^2)$  and load torque  $\tau L=10.2(N \cdot m)$
- Deceleration beginning rotational speed:  $N_2=1800(min^{-1})$
- Deceleration end rotational speed :  $N_1=0(min^{-1})$
- Braking time :  $t=3(sec)$
- A cycle braking and repeatedly. :  $T=5 \text{ minute } (300sec)$
- Starting voltage of DB operation :  $720[V]$

[actual calculation]

#### ① Selection of a braking resistor

From expression (3), system moment of inertia  $J [kg \cdot m^2]$  is,

$$J = \frac{GD^2}{4} = \frac{0.57 + 5.43}{4} = 1.5 [kg \cdot m^2]$$

From expression (1), Regeneration energy  $E [J]$  is ,



$$\begin{aligned}
E &= \frac{J}{2} \times \left[ \left( \frac{2\pi N_2}{60} \right)^2 - \left( \frac{2\pi N_1}{60} \right)^2 \right] \times \eta_M \\
&= \frac{1.5}{2} \times \left[ \left( \frac{2\pi \times 1,800}{60} \right)^2 - \left( \frac{2\pi \times 0}{60} \right)^2 \right] \times 0.845 \\
&= 22,518 \text{ [J]}
\end{aligned}$$

From expression (2), braking torque  $\tau$  [N · m] required for a slowdown is,

$$\begin{aligned}
\tau &= \frac{2\pi J}{60} \times \frac{N_2 - N_1}{t} = \frac{2\pi \times 1.5}{60} \times \frac{1,800 - 0}{3} \\
&= 94.2 \text{ [N · m]}
\end{aligned}$$

From expression (4), braking torque  $\tau_B$  [N·m] required for an inverter is,

$$\tau_B = \tau - \tau_L = 94.2 - 10.2 = 84.0 \text{ [N·m]}$$

From expression (5), the instantaneous maximum regeneration power  $P_B$  [W] at the time of a slowdown start is,

$$P_B = \frac{2\pi}{60} \times N_2 \times \tau_B = \frac{2\pi}{60} \times 1,800 \times 84.0 = 15,834 \text{ [W]}$$

From expression(6), resistance  $R_{DB}$  [ $\Omega$ ] of the braking resistor to select,

$$R_{DB} \leq \frac{(V_{DB})^2}{P_B} = \frac{(720)^2}{15,834} = 32.7 \text{ [\Omega]}$$

Since it becomes the above, two-piece series connection is actually selected for resistance of resistance 15 [ $\Omega$ ].

From expression(7), average power  $P_{DBR}$  [W] consumed by the selected braking resistor is,

$$P_{DBR} \text{ [W]} = \frac{E}{T} = \frac{22,518}{300} = 75 \text{ [W]}$$

Since it becomes the above, the resistance (at this example computation, it is about 400-800 [ $\Omega$ ] grade by the two braking resistor sum total) in consideration of a rise in heat of rated apparent power is selected.

## ② The dosis tplarate of the transistor built in DBunit

From expression (8), when the transistor built in DBunit is set to ON, current  $I_{DB}$  [A] which flows into a transistor becomes below.

$$I_{DB} \text{ [A]} = \frac{V_{DC(MAX)}}{R_{DB}} = \frac{800}{15 \times 2} = 26.7 \text{ [A]}$$

From figure 5.2, since the permissible current value at the time of the total braking time  $t=3$  [sec] is 50 [A] in VFDB2009-50, it can check that it is satisfactory by  $I_{DB}=26.7$  [A].

From expression (9), effective alternating current  $I_{DB(rms)}$  [A] of the whole in consideration of the period of OFF of the transistor which DB unit builds in is as follows.

$$I_{DB(rms)} \text{ [A]} = \frac{V_{DC(MAX)}}{R_{DB}} \times \sqrt{\frac{t}{2T}} = 26.7 \times \sqrt{\frac{3}{2 \times 300}} = 1.9 \text{ [A]}$$

From figure 5.2, since a D.C. continuation permissible current value is 12 [A] in VFDB2009-50, it can check that it is satisfactory by  $I_{DB(rms)} \text{ [A]}=1.9$  [A].

A set of power generation brake system selected from above ① and ② is as follows.

- DB unit : VFDB2009-50 1 set

- Braking resistor:1.5[Ω](200~400[W]) 2 pieces
- ※ Braking resistor should select the small value of a inductance.

### 6.3 Selection of thermal relay

Thermal relay is a detector which DB unit becomes loss of control and prevents overheating of a braking resistor, and is made to trip MCCB (or MC) of an inverter power supply.

Select the operating time of Thermal relay so that the state more than the maximum braking power operates in 30 to 60 seconds. Keep in mind that it becomes a cause of a fire when the thermal relay does not operate. Moreover, a thermal relay should use what operates with D.C. current.

### 6.4 Example of peripheral equipment selection

Example of selection of DB unit and a braking resistor, and a thermal relay is shown in the following table.

Table 6.1 Example of selection

Inverter power source voltage	Brake resistor	Thermal relay		Maximum braking power [kW]	Peak current [A]	DB unit type
		Type	Setting value[A]			
200V series (Starting voltage of DB operation 360V)	1.5 Ω×5S	N20 form	13.0	17.3	48	VFDB2009-50
	1.5 Ω×5S 2P	N60A form	26.0	34.6	96	VFDB2009-200
	1.5 Ω×5S 3P	N60A form	39.0	51.9	144	
	1.5 Ω×5S 4P	N60A form	50.0	69.2	192	
400V series (Starting voltage of DB operation 720V)	3.3 Ω×7S	N20 form	8.5	22.4	31	VFDB2009-50
	3.3 Ω×7S 2P	N60A form	17.0	44.8	62	VFDB2009-200
	3.3 Ω×7S 3P	N60A form	25.0	67.2	94	
	3.3 Ω×7S 4P	N60A form	34.0	89.6	125	
	3.3 Ω×7S 5P	N60A form	42.0	112.0	156	
	3.3 Ω×7S 6P	N60A form	50.0	134.4	187	

- ※ Combination exceeding 1.5 times of the inverter capacity to be used of the maximum braking power is not made.
- ※ Since the resistor and thermal relay of Table 6.1 are the selection articles of our company, please ask in the case of use.

# Chapter 7 Option

Communication option board DBIF2009-Z and the cover for DB units are prepared for VFDB2009 series dynamic brake system as an option.

## 7.1 Communication option board [DBIF2009-Z PC board]

If a communication option PC board is used, communication with VF66 series inverter (the capacity only of a model of 30kW or more) will be attained, and operation which synchronized with the inverter will be attained.

- ※ At the time of single operation of VFDB2002 series dynamic brake system and a parallel operation with VFDB2002 series dynamic brake system, a communication option substrate is inapplicable.
- ※ When communicating using a communication option PC board, the number connected to parallel of VFDB2009 series dynamic brake system with the capacity of VF66 series inverter has restriction. The 30 to 55kW model of VF66 series inverter should carry out the DB unit maximum parallel number to two sets. (The DB unit maximum parallel number of the 75kW or more model of VF66 series inverter is six sets.)
- ※ The wiring length of the telecommunication cable from VF66 series inverter to DB unit of a termination should give as a maximum of 5 [m].

### 7.1.1 Extension of the function by applying of a communication option PC board

The following functions are added by using communication option PC board DBIF2009-Z.

○ **Adjustment of the display gain /offset of D.C. voltage becomes unnecessary.**

In order to make the Vdc detection value of DB unit the same as the Vdc detection value of an inverter, adjustment of a Vdc display gain and Vdc display offset becomes unnecessary.

Note) Set up the power supply voltage system of DB unit in accordance with the power supply voltage system of an inverter. In a mistaken setup, a Vdc display will be unusual. Refer to "5.4.3F20 (Power supply voltage selection and Master/Slave selection and Station number set-up mode)" for a setup of a power supply voltage system.

○ **Starting voltage of DB operation is set automatically.**

The preset value (F-00: built-in DB operation level) of an inverter is automatically set to Starting voltage of DB operation of DB unit. Refer to the instructions manual of VF66 series inverter for the preset value of VF66 series inverter.

Note) At the time of communication option substrate use, the setting range of Starting voltage of DB operation becomes narrow. (It is restricted to the setting range of an inverter.)

Table 7.1 Set-up range of DB operation starting voltage

	Set-up range	
	200V series	400V series
At the time of communication option PC board not use	300-400V	600-800V
At the time of communication option PC board use	320-360V	640-720V

○ **Inverter operation is received by communication.**

Since the state of an inverter operation point of contact (52MA) comes to be sent by communication, wiring is simplified.

○ **The protection state of DB unit can be displayed on an inverter.**

A protection state is displayed for DB unit on an inverter at the time of failure. Furthermore, when DB unit is in a protection state, an inverter is stopped, or not stopped selection is possible. Refer to "7.1.7 Set-up of the inverter at the time of communication option PC board use" for details. Moreover, a up rank unit (sequencer) can be told about failure of DB unit via an inverter.

7.1.2 Communication option DBIF2009-Z PC board

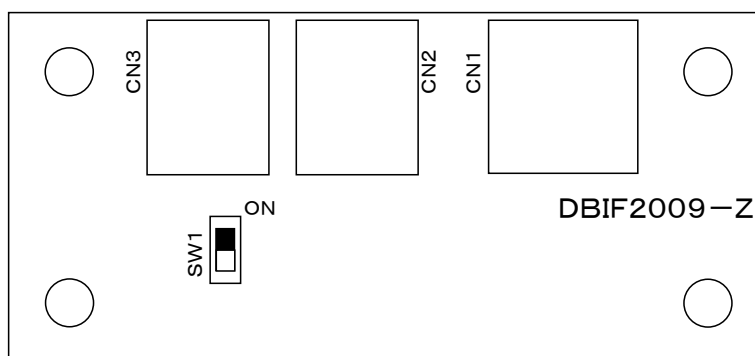

Figure 7.1 DBIF2009-Z PC board

Table 7.2 List of parts use and functions on the DBIF2009-Z printed cuicuit board

Name	Parts use and functions
CN1	The connector for connection with a VFDB2009-Z PC board
CN2	VF66 series inverter (model of 30kW or more) and the connector for connection with a
CN3	DBIF2009-Z PC board
SW1	Terminator ON/OFF change switch

### 7.1.3 Attachment of a communication option board, connection of a connector

Attach communication option board DBIF2009-Z to DB unit main part by the following methods.

- ① The metal thread part of an attached spacer (BMP-310E) is attached to a total of four holes in the left-hand side side part of DB unit main part. (Please also attach a spring washer and a washer together with a spacer.)

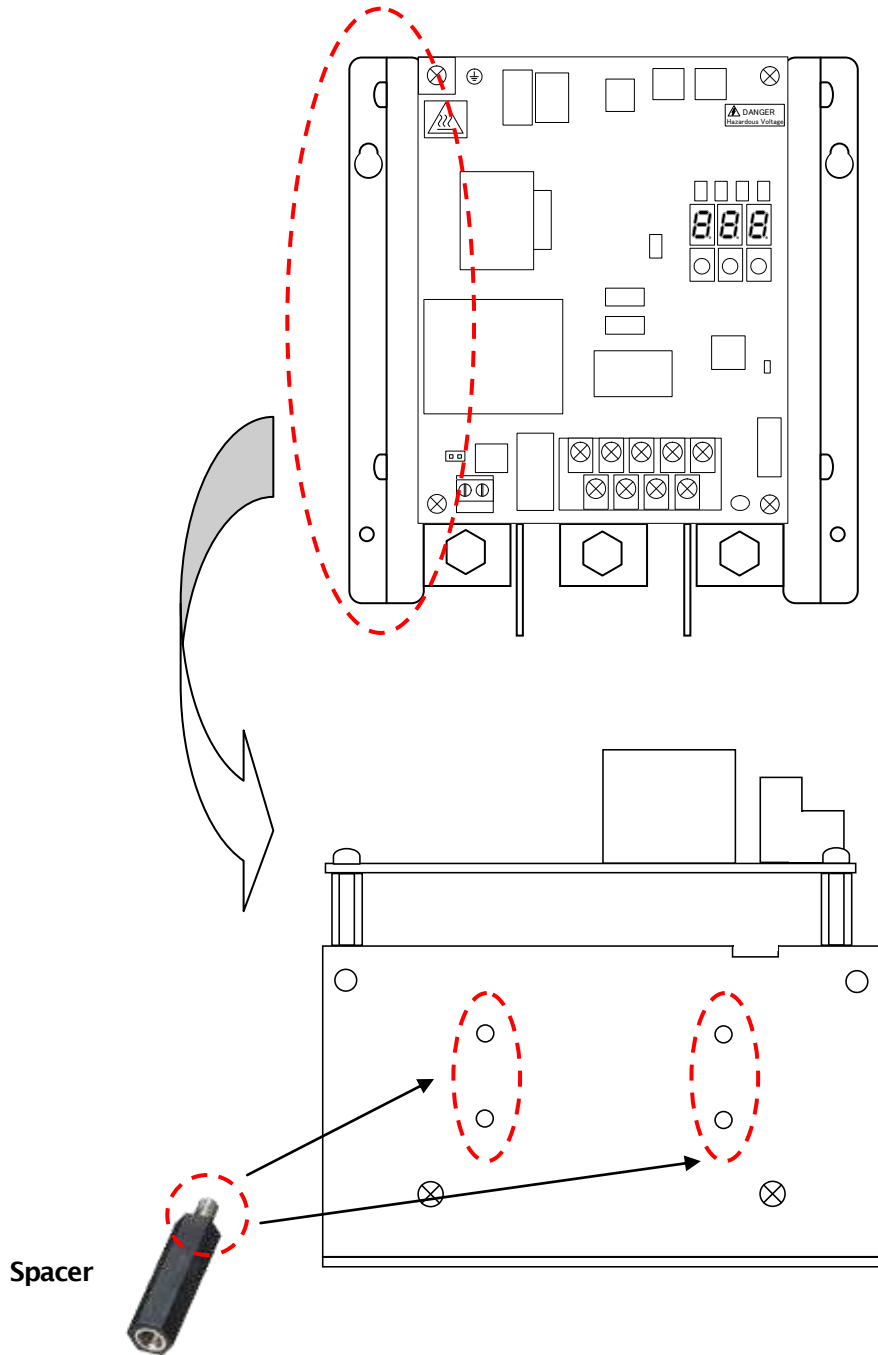

Figure 7.2 DBIF2009-Z PC board attachment ①

② DBIF2009-Z board is attached to the spacer attached by ① with the screw of M3.

DBIF2009-Z PC board

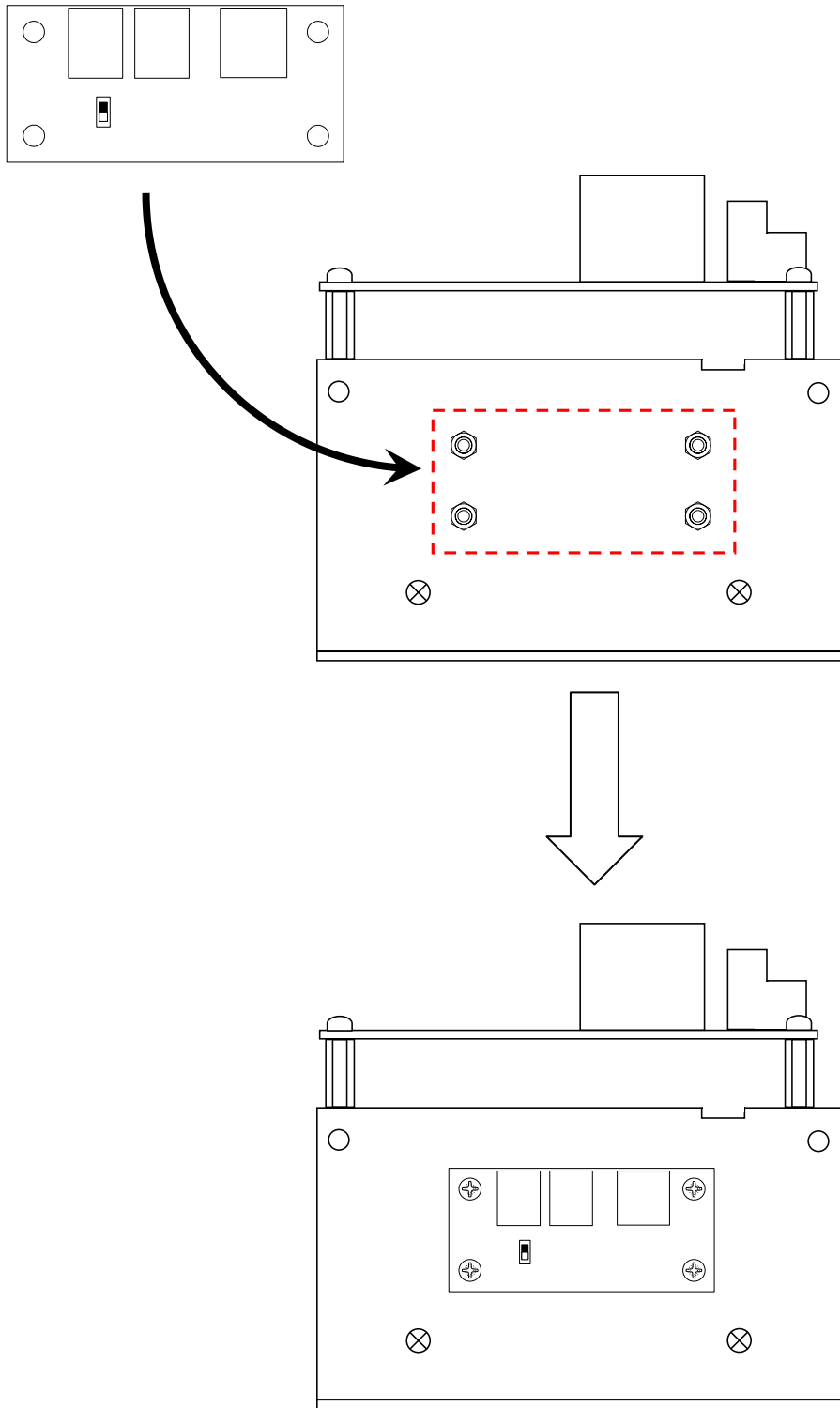

Figure 7.3 DBIF2009-Z PC board attachment ②

### 7.1.4 Connection of a telecommunication cable and a setup of a terminator switch

Perform connection of a telecommunication cable and a setup of a terminator switch by the following methods.

The terminator switch of DBIF2009-Z turns ON only DBIF2009-Z of a termination.

A noise cut core (product made from ESD-R-47 B:Tokin) is inserted in a communication line. The number of turns is 2 or more turns, please insert a noise cut core in the DB unit side between an inverter and DB unit, and insert in the latter DB unit side between DB unit and DB unit.

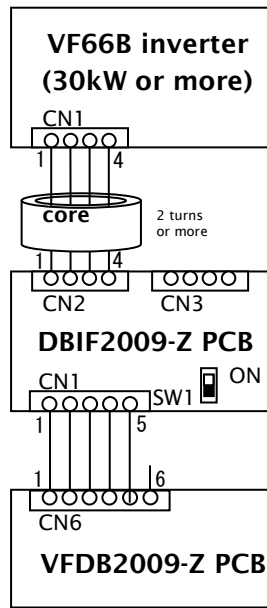

Figure 7.4 Connection and terminator switch set-up at the time of DB unit single operation

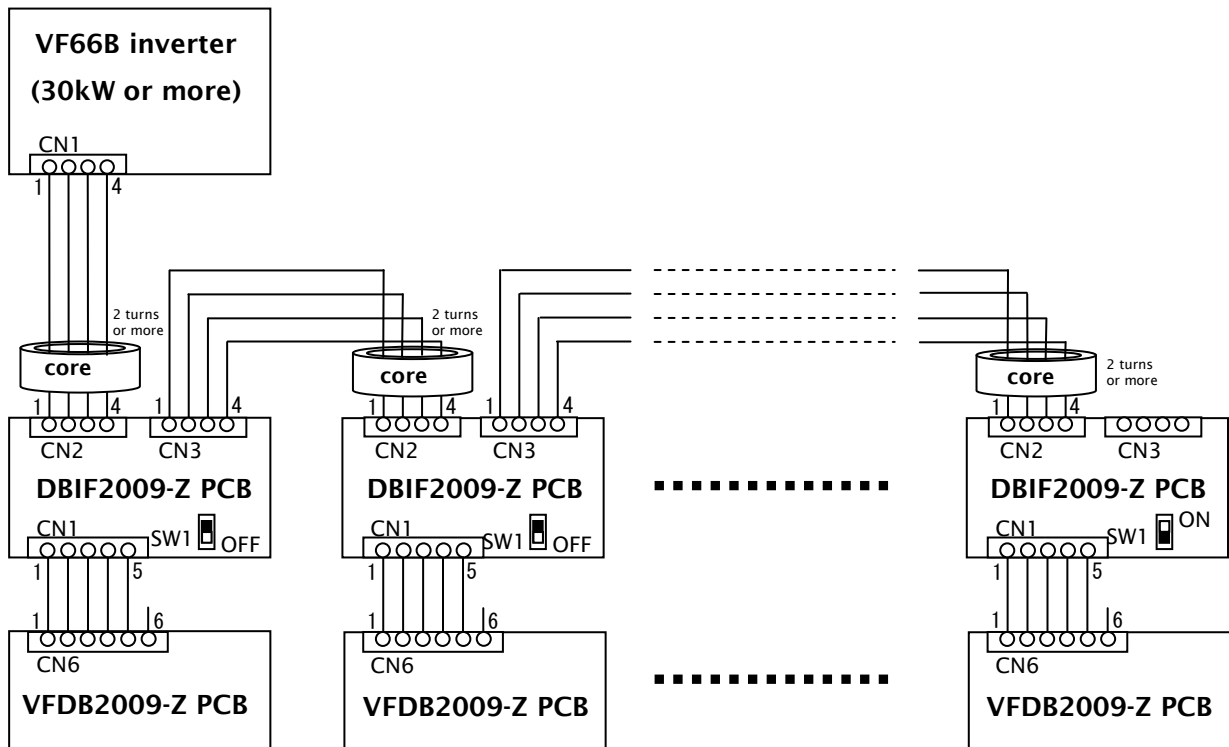

Figure 7.5 Connection and terminator switch set-up at the time of DB unit parallel operation (the maximum parallel number six sets)

- ① The connector by the side of 5 pins of an attached cable is connected with connector CN1 of a DBIF2009-Z board.

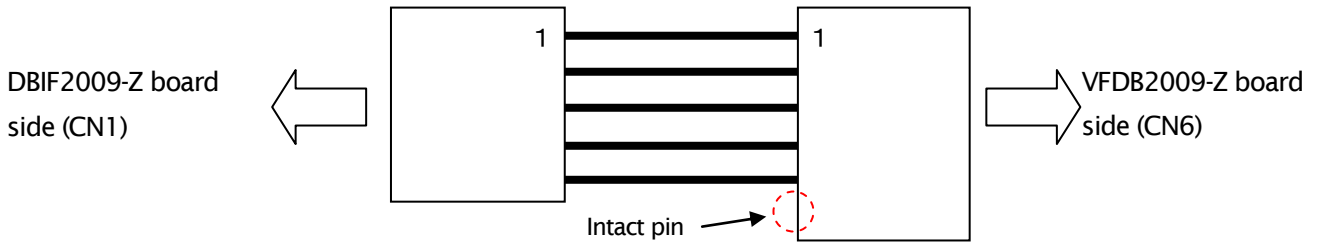

Figure 7.6 Attached cable

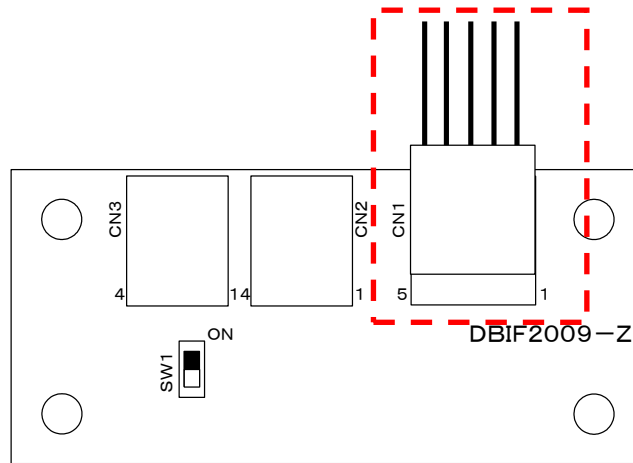

Figure 7.7 Connection between attached cable and DBIF2009-Z board

- ② The connector by the side of 6 pins of an attached cable is connected with connector CN6 of a VFDB2009-Z board. When DB unit is connected in parallel, please make connection between each attached cable, and a DBIF2009-Z board and a VFDB2009-Z board like the above-mentioned ① and ②.

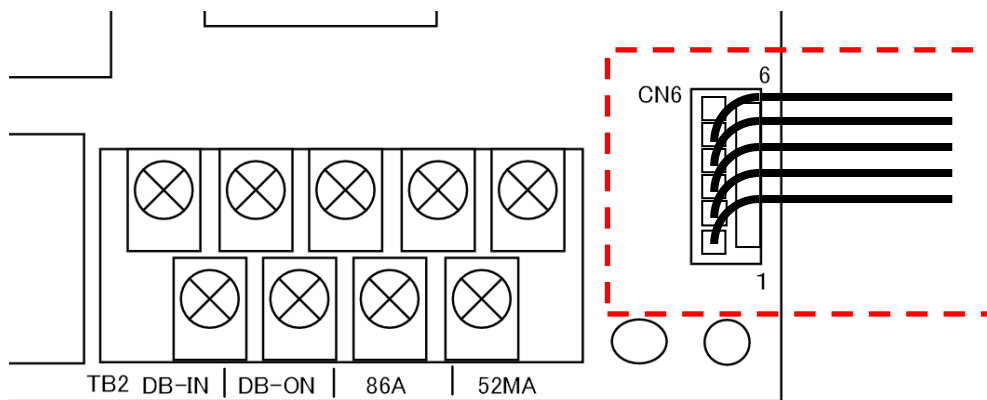

Figure 7.8 Connection between attached cable and VFDB2009-Z board



- ③ The communication cable which connects a DBIF2009-Z board and VF66 series inverter is not attached. Please manufacture a connecting cable with reference to the parts of Table 7.3.

Table 7.3 Cable parts between DBIF2009-Z PC board and VF66 inverter

	Name	Type	Maker	Quantity	Remarks
CN2 or CN3 (DBIF2009-Z side)	Housing	5051-04	Molex	1	
	Terminal	2759G	Molex	4	Gilding processing article
CN1 (VF66 inverter side)	Housing	DF1E-4S-2.5C	Hirose	1	
	Terminal	DF1B-2022SCA or DF1B-2022SCFA	Hirose	4	Gilding processing article
Cable ※1	Cable	CO-SPEV-SB(A) 2P×0.5SQLF	Hitachi cable	1	Recommendation

※1 : An equivalent article is also good for a cable. The line of a connector 1 and two pins and the line of 3 and 4 pins are made to twist, respectively.

- ④ The connector by the side of the DBIF2009-Z board of the cable manufactured by the above-mentioned ③ is connected with the connector CN2 or CN3 of a DBIF2009-Z board.

It is O.K. whichever it connects of CN2 and CN3.

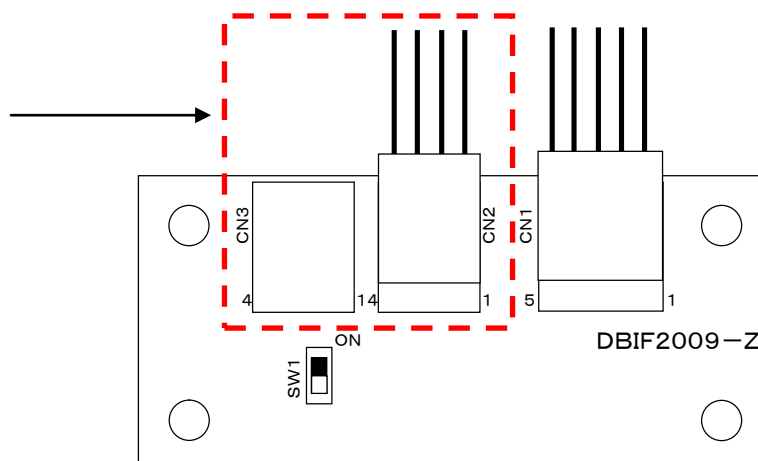

Figure 7.9 Connection① between DBIF2009-Z PC board and VF66 inverter

- ⑤ The connector by the side of the VF66B inverter of the cable manufactured by the above-mentioned ③ is connected with connector CN1 of a VF66B inverter. When connecting a connector to a VF66B inverter, a cable is taken in from the lower part of an inverter and it connects with connector CN1 for communication in the inside of an inverter. (The positions of the connector for communication differ depending on the model of a VF66B inverter.)

VF66B inverter (Capacity of 30kW or more)

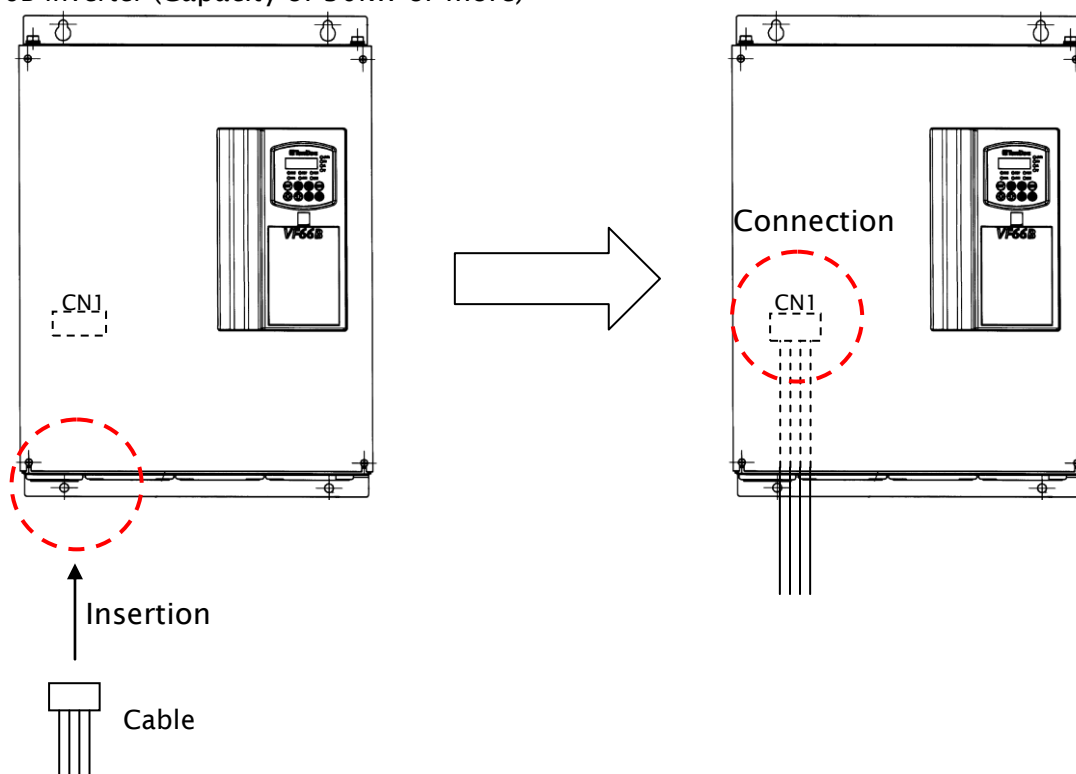

Figure 7.10 Connection② between DBIF2009-Z PC board and VF66 inverter

- ⑥ **In the case of the parallel operation of DB unit**, the telecommunication cable which connects a DBIF2009-Z board and a DBIF2009-Z board is required. The cable is not attached. Please manufacture a connecting cable with reference to the parts of Table 7.4.

Table 7.3 Cable parts between DBIF2009-Z PC board and DBIF2009-Z PC board

	Name	Type	Maker	Quantity	Remarks
CN2 or CN3 (DBIF2009-Z side)	Housing	5051-04	Molex	1	
	Terminal	2759G	Molex	4	Gilding processing article
CN2 or CN3 (DBIF2009-Z side)	Housing	5051-04	Molex	1	
	Terminal	2759G	Molex	4	Gilding processing article
Cable ※1	Cable	CO-SPEV-SB(A) 2P×0.5SQLF	Hitachi cable	1	Recommendation

※1 : An equivalent article is also good for a cable. The line of a connector 1 and two pins and the line of 3 and 4 pins are made to twist, respectively.

- ⑦ The cable manufactured by the above-mentioned ⑥ is connected with which of CN2 of a DBIF2009-Z board, and CN3, or a vacant connector. When connecting two or more sets of DB units in parallel, a cable is connected with reference to Figure 7.5 and 7.11

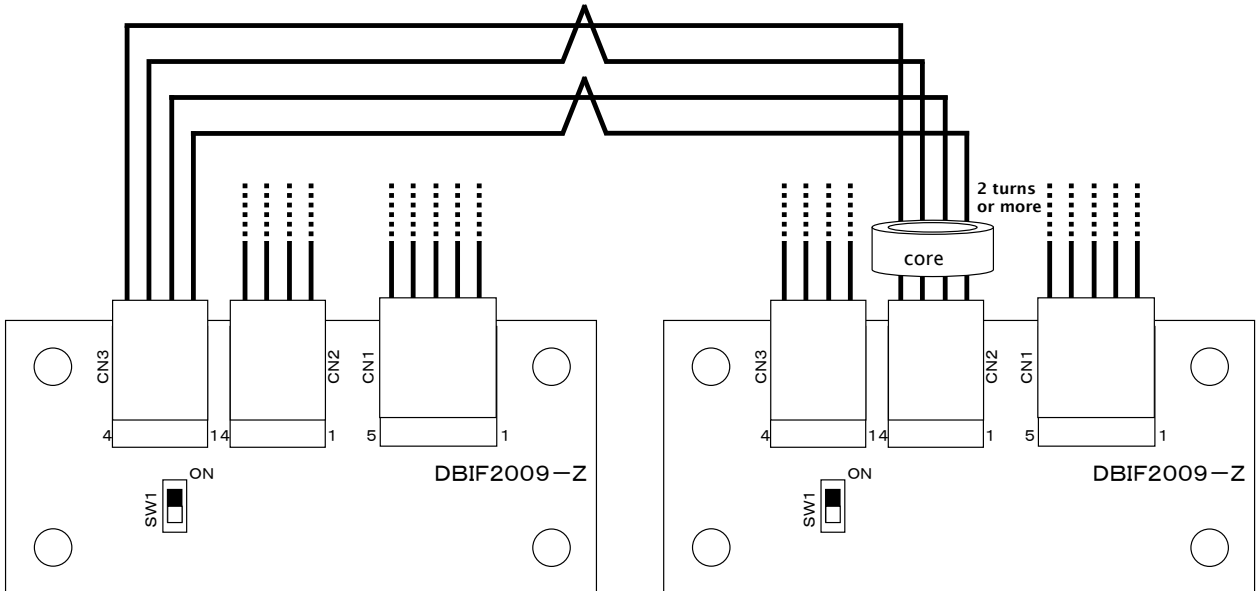

Figure 7.11 Connection between DBIF2009-Z PC board and DBIF2009-Z PC board

- ⑧ Terminator switch SW1 on a DBIF2009-Z board is switched. If a switch is moved to the ON side, it will become Switch ON, and it will become Switch OFF if it moves to the opposite side. Refer to Fig. 7-5 and Fig. 7-12 for details.

[Single operator] : Certainly set as ON

[Parallel operation]: Only SW1 of DBIF2009-Z of DB unit of the end connected in parallel is set to ON, and SW1 of the other unit sets to OFF.

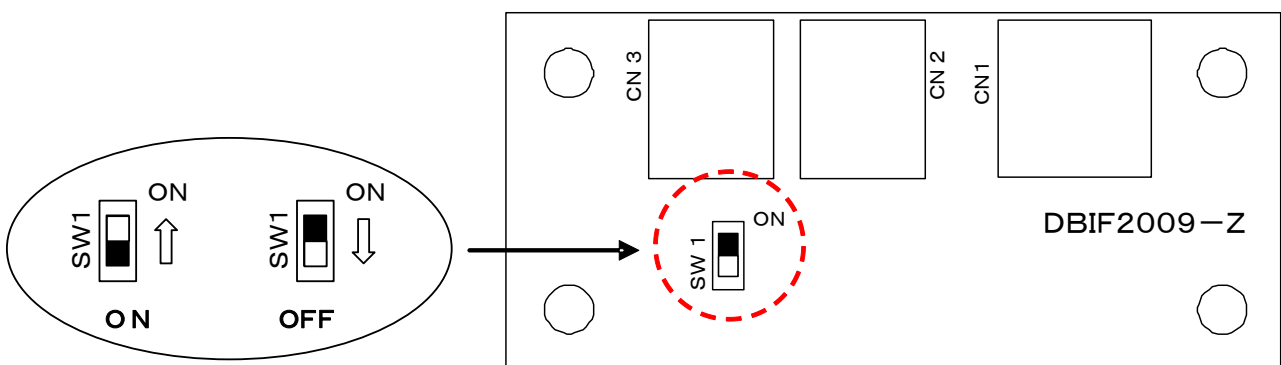

Figure 7.12 Change of terminator on DBIF2009-Z PC board

### 7.1.5 Station number set-up

At the time of communication option substrate use, a setup of a station number is required of F20 set-up mode (Power supply voltage selection and Master/Slave selection and Station number set-up mode). Refer to the "5.4.3 F20 (Power supply voltage selection and Master/Slave selection and Station number set-up mode) for the procedure of a setup.

If the abnormalities in communication or DB unit becomes protection mode, it will be displayed as "dbO" on a VF66B series inverter. "O" is the code set up in F20 setting mode. Refer to "9.4 Protection o at the time of communication option use" for protection mode.

### 7.1.6 Main circuit wiring at the time of communication option PC board attachment

In the time of communication option substrate attachment, the time usually differs from wiring. About Master/Slave selection and power supply voltage selection, it is usually the same as that of the time. "5.2.1 Change of power supply voltage" and "5.2.2 Set-up of single operation or Master/Slave system operation" are referred to, Please perform various setup.

#### ◎Single operation

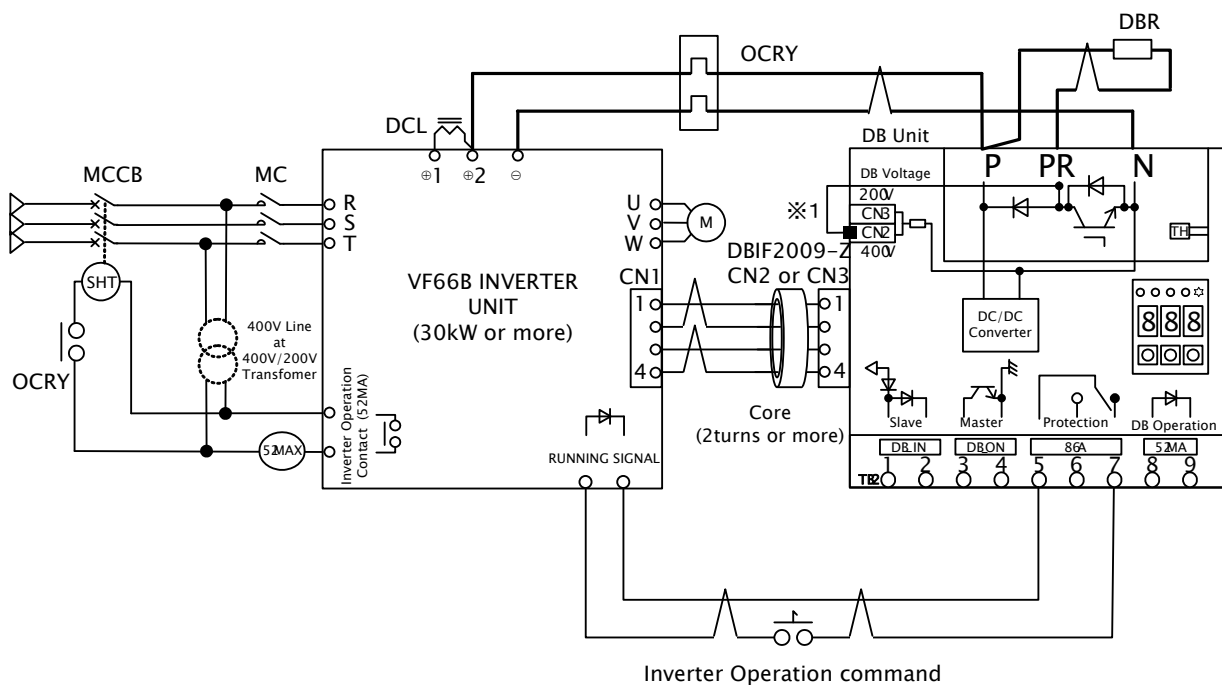

Figure 7.13 Example of connection diagram at the time of single operation  
(At the time of communication option PC board application)

- ※1 : Change the connector on DB unit according to the voltage system of an inverter. Refer to "5.2.1 Change of power supply voltage" for details.
- ※2 : Wiring of VF66 inverter should follow the instructions manual of inverter each model.
- ※3 : Inside of a figure 3 of a part  $\Delta$  of the connection example wires for the twist. Please lay out the equipment to shorten as much as possible and wire for wiring. If the twist line is not used, the surge voltage is by the twice or more. there is a possibility of damaging the unit.

※4 : Please connect input power source (P,N) of DB unit from the middle D.C. power (⊕ 2, ⊖) of the inverter unit by twist cable. Refer to Table 3-1 of "3.2 connection" for the size of the use cable and number of time to twist .

※5 : Refer to "3.2 Connection " for notes at the time of wiring.

### ◎Paralle operation

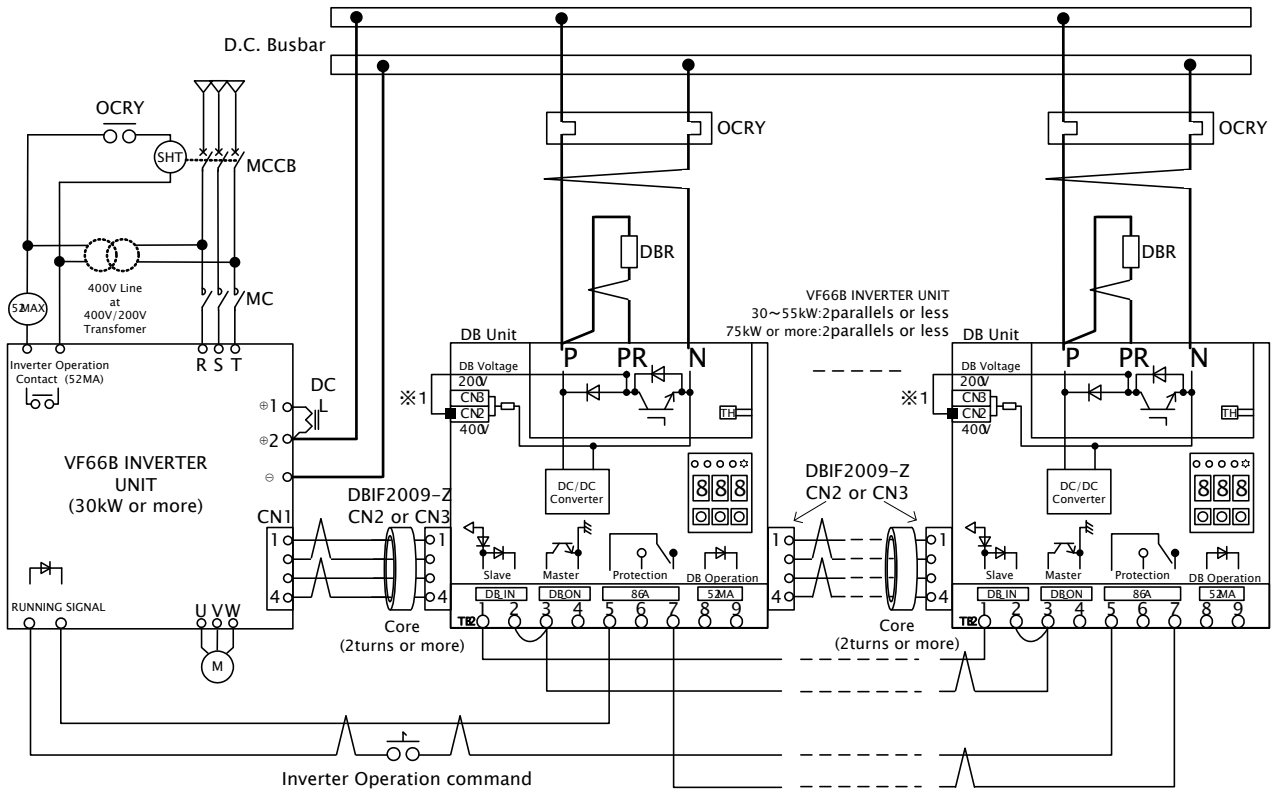

Figure 7.14 Example of connection diagram at the time of single operation  
(At the time of communication option PC board application)

- ※1 : Change the connector on DB unit according to the voltage system of an inverter. Refer to "5.2.1 Change of power supply voltage" for details.
- ※2 : Wiring of VF66 inverter should follow the instructions manual of inverter each model.
- ※3 : Inside of a figure 3 of a part  $\Delta$  of the connection example wires for the twist. Please lay out the equipment to shorten as much as possible and wire for wiring. If the twist line is not used, the surge voltage is by the twice or more. there is a possibility of damaging the unit.
- ※4 : Refer to Table 3-1 of "3.2 connection" for the size of the use cable of the input power source (P,N) of DB unit.
- ※5 : Refer to "3.2 Connection " for notes at the time of wiring.

### 7.1.7 Set-up of the inverter at the time of communication option PC board use

When attaching a communication option substrate to DB unit and communicating with a VF66B inverter, the number of DB unit linked to an inverter is set up (J-15). The absolute value of J-15 shows the number of connection of DB unit, when J-15 is positive (J-15>0), in the case of the protection mode of DB unit, the display for indication of an inverter is displayed as "dbO" (O numerical value of station number), and operation of an inverter is continued. When J-15 is negative (J-15<0), in the case of the protection mode of DB unit, it is displayed on the display for indication of an inverter as "dbO" (O numerical value of station number), and an inverter serves as protection mode and stops operation. Refer to the instructions manual of a VF66B series inverter for the preset value of an inverter.

Table 7.5 Setup of an inverter

Display	Description	Set-up range	Initial value
J-15	Number of DB unit of external connection with a communication option	-6~6	0

## 7.2 Option cover

---

DB unit has a cover as an option as an object for the prevention from substrate contact with a PC board. For details, please consult to the operating window of our company.

# Chapter 8 Replacement with the old model DB unit

## 8.1 Replacement with VFDB2002 series

VFDB2009 series power dynamic brake system has compatibility in VFDB2002 series power dynamic brake system, attachment, and an operating method. When you exchange VFDB2002 series to VFDB2009 series, please make wiring and a setup of VFDB2009 the same as VFDB2002. ( Refer to "8.3 Parallel operation method with VFDB series.")

Furthermore, VFDB2002 series and VFDB2009 series are mixed and a parallel operation is possible. In this case, make wiring and a setup of VFDB2009 the same as VFDB2002.

※ In VFDB2002 series and VFDB2009 series differs from to change of power supply voltage, to select of power supply series and to set of voltage width which stops DB operation. For details, refer to the instructions manual of VFDB2002 series.

Table 8.1 Old and new DB unit compatible table

Built-in transistor permissible current	Cooling system	Old DB unit	Alternative DB unit
50A	Natural cooling	VFDB2002-50	VFDB2009-50
200A	Natural cooling	VFDB2002-200N	VFDB2009-200N
200A	Air cooling with blower	VFDB2002-200F	VFDB2009-200F

## 8.2 Replacement with VFDB5022, VFDB5044, VFDB91-200

Connection, operation method and the operation / setting method differ from by VFDB2009 series and VFDB5022, VFDB5044, VFDB91-200. When exchanging to VFDB5022, VFDB5044, and VFDB91-200 to VFDB2009 series, it is necessary to change wiring with an inverter. Refer to "3.2 Connection" for wiring of VFDB2009.

In addition, please keep in mind that it cannot perform the parallel run of VFDB2009 series, and VFDB5022, VFDB5044 and VFDB91-200.

Table 8.2 Old and new DB unit compatible table

Old DB unit	Alternative DB unit
VFDB5022	VFDB2009-50(Set as 200V series)
VFDB5044	VFDB2009-50(Set as 400V series)
VFDB91-200	VFDB2009-200N

### 8.3 Parallel operation method with VFDB series

#### 8.3.1 Setup of VFDB2009 series

The parallel operation of only VFDB2002 series is "Method of Master/Slave" with which DB operation voltage detects and the master unit set up in DB unit takes out instructions of ON/OFF of switching device (IGBT) to Slave unit. Therefore, in the case of the parallel operation of VFDB2002 series and VFDB2009 series, it is considered as a setup of the master/slave of VFDB2009 series. Refer to "5.2.2 Set-up of single or Master/Slave system parallel operation" for the setting method. In addition, either VFDB2009 series or VFDB2002 series can use a master unit. In VFDB2002 series and VFDB2009 series differs from to change of power supply voltage and to set of stopping voltage of DB operation. Refer to the instructions manual of VFDB2002 series.

#### 8.3.2 Connection

In the case of the parallel operation of VFDB2009 series and VFDB2002 series, it connects like Figure 8.1.

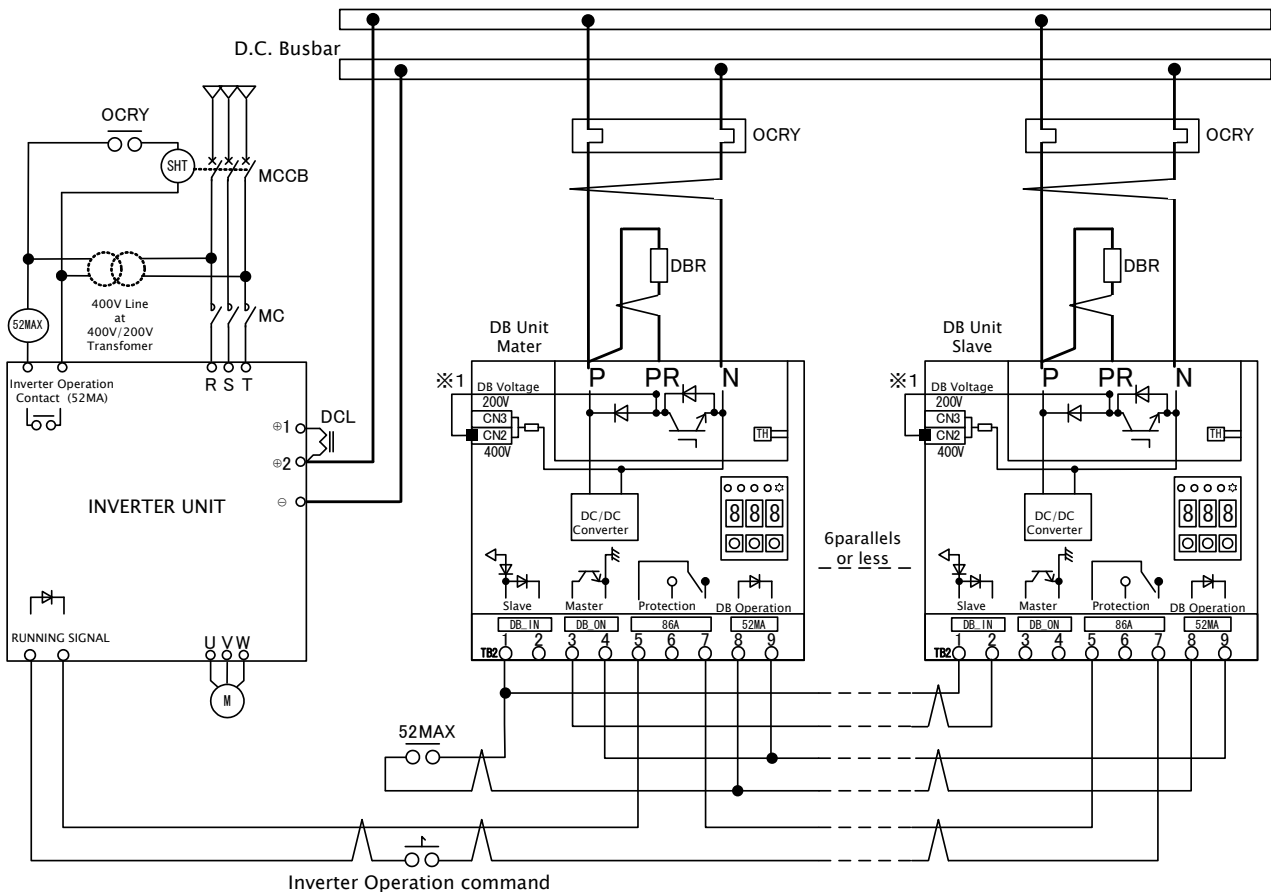

Figure 8.1 Example of wiring at the time of a parallel operation with VFDB2002 series

- ※1 : Change the connector on DB unit according to the voltage system of an inverter. Refer to "5.2.1 Change of power supply voltage" for details.
- ※2 : Wiring of VF66 inverter should follow the instructions manual of inverter each model.
- ※3 : Inside of a figure 3 of a part  $\Delta$  of the connection example wires for the twist. Please lay out the



equipment to shorten as much as possible and wire for wiring. If the twist line is not used, the surge voltage is by the twice or more. there is a possibility of damaging the unit.

※4 : Refer to Table 3-1 of “3.2 connection” for the size of the use cable of the input power source (P,N) of DB unit.

# Chapter 9 Trouble shooting

## 9.1 Protect display

When abnormalities occur in VFDB2009 dynamic brake system and the protection operates, DB operation is stopped immediately, 86A points of contact are operated, 86A of LED lights up, and the contents of protection are displayed on the display for indication of DB unit. The list of the protection displays of DB unit is shown in the following table.

Table 9.1 List of protect display

Protect display	Protect content	Discription of protect optaion
FF1	Abnormalities of main circuit)	A braking resistor is un-connecting., IGBT failure
FF2	Cooling fin overheating)	When the temperature of IGBT becomes beyond a predetermined value
FF3	Abnormalities of preset value	When the preset values memorized by RAM or EEPROM are abnormalities
FF4	Over voltage of 200V series	When D.C. voltage exceeds 450V in 200V series at the time of a setup

## 9.2 Trouble shooting

When operation is correctly impossible or the problem of a certain abnormalities having arisen during operation occurs, please investigate a cause by the following check methods and cope with it. When the problem applicable to neither of the next measure arises, please contact to agency of our company, or our company.

Table 9.2 List of trouble shooting

Protect display	Cause	Measure
FF1	①A braking resistor is un-connecting.	A braking resistor is connected between P and PR.
	②IGBT breaks down	DB unit is exchanged.
	③ Each of power-supply-voltage system change connector CN2 and CN3 is un-inserting.	A connector is inserted. (Refer to "5.2.1 change of power supplyvoltage.")
FF2	①Ambient air temperature is high.	The environment where DB unit is installed checks in conformity in specification. (Refer to "2.1 common specification.")
	②There is not an enough cooling space.	Please secure a regular cooling space. (Please refer to "3.1 installation.")
	③ The direction of installation is not suitable.	Please install in the regular direction of installation. (Please refer to "3.1 installation.")
	④A fan motor is failure or a defect of operation. (only VFDB2009-200F)	Please exchange a fan motor.
	⑤ It is not applied to which of the above-mentioned ① to ④.	DB unit, a braking resistor, and a thermal relay are reselected. (Refer to "Chapter 6 Selection of peripheral device.")
FF3	①The write-in defect to EEPROM occurs by an excessive noise.	DB unit takes noise measures and a preset value is initialized.
FF4	①At the time of inverter use of 400Vseries, setup of DB unit is 200Vseries.	A setup of a power supply voltage of DB unit and a power supply voltage change connector are checked. (Refer to "5.2.1 change of power supplyvoltage.")
	②Power supply voltage is rising unusually.	Please check an input power supply.



## **DANGER** [Check of wiring]

- Wiring is checked after checking that the inverter and the CHG lamp of a VFDB2009-Z board have gone out. Failure to do so may cause an electric shock.

### 9.3 Reset

#### **[In the case of FF1(Abnormalities of main circuit), FF2(Cooling fin overheating), FF4(Over voltage of 200V series)]**

The protection mode of DB unit is held until a power supply is lost. Reset in the protection mode of DB unit turns OFF the power supply of DB unit. Protection mode will be cleared, if the power supply of DB unit is turned off once and a power supply is turned ON again. In holding protected operation, it prepares a hold circuit in an external circuit.

When the protection of FF4 operates and the cause is a setting mistake in power supply voltage series selection, after setting up F20 correctly, the power supply of DB unit is turned off, and a power supply is turned on again.

#### **[In the case of FF3(Abnormalities of preset value)]**

The protection display of FF3 (abnormalities of preset value) is not cleared even if it turns off the power supply of DB unit. There is the necessity for initialization of a preset value in clearing the protection display of FF3. Initialize a preset value according to the following procedures.

- ① Pushing each button of "UP", "DOWN", and "FNC/SET" is continued simultaneously.
- ② The button of "DOWN" and "FNC/SET" is detached in the state where each button is pushed by ①.
- ③ A display switches from a protection display to F10 setting mode. Each preset value before initialization is recorded. The preset value of Vdc display offset in F40 setting mode is changed into "FF."
- ※ Do not push the "FNC/SET" button after having changed setting.
- ※ Refer to "5.1.3 Operation method of display for indication" for operation of a display for indication, refer to "5.4.5F40 (The display gain /offset hand adjustment mode of D.C. voltage)" for F40 setting mode.
- ④ The power supply of DB unit is turned OFF.

Initialization is completion above. If a power supply is turned ON again, a protection display will be cleared and a preset value will be changed into an initial value. After initialization certainly perform various setup. The display gain / offset adjustment of D.C. voltage sets up the value indicated on the label stuck on RY1 (refer to Figure 5.1) on a VFDB2009-Z board by "5.4.5. F40(The display gain / offset hand adjustment mode of D.C. voltage)"

Operation of this initialization is returned to the initial value before adjusting the preset value of DB unit. Therefore, do not usually perform initialization operation.

## 9.4 Protection oat the time of communication option use

---

When attaching communication option DBIF-2009 to VFDB2009 dynamic brake syytem and communicating with VF66 series inverter, if DB unit becomes the protection mode of Table 9.1, it will be displayed on the display for indication of an inverter as "db\*" (\* numerical value of station number). Furthermore, also when communication cuts, an inverter serves as protection mode and is displayed on the display for indication of an inverter as "db\*" (\* numerical value of station number). However, the distinction in the protection mode of DB unit cannot do an inverter.

An inverter detects communicative cutting. Therefore, DB unit does not serve as protection mode. An inverter should serve as protection mode, and when DB unit is not in protection mode, please check the loose connection of a communication connector, cutting of a communication line, wiring of a communication line, and the preset value of DB unit and the preset value of an inverter.

When performing communication with DB unit and an inverter, the inverter can respond by the following function to the protection mode (communicative cutting is included) of DB unit.

At the time of the protection mode of DB unit, it can be chosen whether operation is continued for an inverter in protection mode, or it stops. Refer to "7.1.7 Set-up of the inverter at the time of communication option PC board use" for the change method.

- ① In the protection mode state of DB unit, multi-function output terminal of an inverter to an output is possible. The preset value H-00-05 (any one) of multi-function output terminal of an inverter to be used is set as 22. Refer to the instructions manual of a VF66B series inverter for the preset value of an inverter.
- ② It is possible to communicate the protection mode state of DB unit to a higher rank unit (sequencer etc.) through the digital communications option independently attached to an inverter. Refer to the instructions manual of a VF66B series inverter, and the instructions manual of each digital communications option for a digital-communications option.
- ③ When DB unit switches an inverter to an operation stop in protection mode by the above-mentioned ① at the time of protection mode, if DB unit becomes protection mode, the data at the time of protected operation will be memorized by one point traceback function of an inverter, a protection history function, and traceback function, and quick restoration is attained. About each function of one point traceback function of an inverter, a protection history function, and traceback function, refer to the instructions manual of a VF66B series inverter, and the instructions manual of VF66PCTool.

# Chapter 10 Maintenance

## 10.1 Regular check

In order to keep the condition of the equipment best at all times and exercises the performance fully, regular check shall be conducted at least every six months and check shall be performed for the place which usual operation monitoring can not check.

Maintenance shall be conducted by the person who has the safety knowledge of electricity.



### CAUTION [Inspection operation]

- Do not open the cover as input power source is turned on.  
Failure to do so may cause an electric shock.
- Please perform inspection after turning off DB unit power source and going out of LED for “CHG” confirmation on VFDB2009-Z circuit printed board.  
Failure to do so may cause an electric shock.  
Failure to follow this warning may cause burns.
- Be careful that the temperature of the radiating fin is high depending on the use conditions.  
Failure to follow this warning may cause burns.



### DANGER [Maintenance and inspection]

- Please perform inspection after input power source is turned OFF and 10 minutes or more pass. In addition, check voltage between P and N and check it is 30V or less.  
Failure to do so may cause an electric shock.
- Do not perform maintenance and inspection by the person other than designated person.  
[Remove metal (watch and ring) before work.]  
Failure to do so may cause an electric shock, personal injury.

#### List of regular check

Items and object	Check content
Appearance of unit	Check that there is no dirt and dust filled with radiating fin and clean.
Cooling fan	Clean if dirt and dust are attached in the cooling fan. In addition, replace fan only as a target of period of endurance of fan (30,000 hours).
Interior unit	Check if dirt and dust are attached on the printed board and other electronic parts.
Terminal block and terminal screw	Check if there is looseness of terminal block and mounting screw, and tighten additionally.
Connector	Check if there is no looseness of connector and terminal of control printed board.
Wiring	Check if there is no abnormality such as crack and deformation in insulating coating of wiring.

## 10.2 Disposal

Dispose of replacement parts and maintenance parts complying with local regulations.

# **TOYODENKI SEIZO K.K.**

---

<http://www.toyodenki.co.jp/>

HEAD OFFICE: Tokyo Tatemono Yaesu Bldg, 1-4-16 Yaesu, Chuo-ku,  
Tokyo, Japan ZIP CODE 103-0028  
TEL : +81-3-5202-8132 - 6  
FAX : +81-3-5202-8150

---

Contents of this manual are subject to change without notice.

2012-09

QG18740C