

## Protein Mapping of the Salivary Complex from a Hematophagous Leech

MARIA ESTHER RICCI-SILVA,<sup>1</sup> KATSUHIRO KONNO,<sup>2</sup> FERNANDA FARIA,<sup>1</sup>  
GANDHI RÁDIS-BAPTISTA,<sup>3</sup> WAGNER FONTES,<sup>4</sup> RETO STÖCKLIN,<sup>5</sup>  
SOPHIE MICHALET,<sup>5</sup> TETSUO YAMANE,<sup>6</sup>  
and ANA MARISA CHUDZINSKI-TAVASSI<sup>1</sup>

### ABSTRACT

The salivary complex of leeches contains many components able to modulate physiological mechanisms, such as coagulation and fibrinolysis, and it is composed by the salivary glands and proboscis, encompassing two different proteomes. The bidimensional electrophoretic pattern of the salivary complex from the *Haementeria depressa* leech revealed a total of 352 spots, 103 in common with the muscular tissue and 249 exclusive from the salivary complex as detected by silver staining; these spots showed isoelectric points from 3.5 to 9.5 and covered an apparent molecular weight range from 10 to 105 kDa. The following isoforms of proteins were identified by mass spectrometry analysis: antiplatelet protein, myohemerythrin and carbonic anhydrase. Since the leeches were not fed for about 2–3 months to stimulate the secretion of proteins that facilitates the blood metabolism, these most abundant proteins in the salivary complex excised from leeches, are expected to play a role during feeding and might have some anti-hemostatic properties. Furthermore, by zymography, a gelatinolytic and a fibrinolytic protein were identified.

### INTRODUCTION

THE HEMATOPHAGOUS INVERTEBRATES, including some species of leeches, have been widely used as model organisms for hemostatic studies, as their saliva contains a diverse array of potent antithrombotic molecules, including anticoagulants, fibrinolytic and inhibitors of platelet aggregation. Some compounds were isolated and characterized from leeches, for instance, inhibitors of coagulation factor Xa: ghilienten (*Haementeria ghilianii*) (Condra et al., 1989), antistasin (*Haementeria officinalis*) (Nutt et al, 1988), and therostasin (*Theromyzon tessulatum*) (Chopin et al, 2000); inhibitors of thrombin: hirudin (*Hirudo medicinalis*) (Haycraft, 1884), theromin (*Theromyzon tessulatum*) (Salzet et al., 2000), haemadin (*Haemadipsa*

---

<sup>1</sup>Laboratory of Biochemistry and Biophysics, Butantan Institute, São Paulo, Brazil.

<sup>2</sup>Laboratory of Mass Spectrometry, CAT/Butantan Institute, São Paulo, Brazil.

<sup>3</sup>Department of Biochemistry and Molecular Biology, Federal University of Ceará, Fortaleza, Brazil.

<sup>4</sup>Brazilian Center for Protein Research, University of Brasília, Brasília, Brazil.

<sup>5</sup>Atheris Laboratories, Geneva, Switzerland.

<sup>6</sup>Laboratory of Molecular Biology, IPEN, São Paulo, Brazil.

## SALIVARY COMPLEX FROM A HEMATOPHAGOUS LEECH

*sylvestris*) (Strube et al., 1993); a fibrinogenolytic protein: hementin (*Haementeria ghilianii*) (Sawdesh et al., 1990); and antagonists of platelet receptors: LAPP (*Haementeria officinalis*) (Connolly et al., 1992); decorsin (*Macrobodella decora*) (Seymour et al., 1990) and ornatin (*Placobdella ornata*) (Mazur et al., 1991). In addition, leeches are used in neurological and immunological studies (Nicholls et al., 1989; De Eguileor et al., 2003). In medicine, the therapeutical application of leeches, used as bloodletting, dates back to ancient time (Eldor et al., 1996). Even nowadays, they are used in microsurgery and in the treatment of patients with post-phlebotic syndrome in which the anti-hemostatic properties of their saliva is helpful (Whitaker et al., 2004).

Protein mapping of the salivary complex from a hematophagous leech like *Haementeria depressa* can help understand the complexity of compounds involved in such physiological systems as hemostasis and digestion. The combination of two-dimensional (2D) electrophoresis and mass spectrometry has been widely used in proteomic analysis and in the identification of proteins (Gygi et al., 2000; Jungblut and Thiede, 1997). A previous work reported the 2D electrophoresis analysis of phosphoproteins expression in leech central nervous system (Garcia-Gil et al., 1991). Proteomic approaches have also been applied for the analysis of hematophagous animal's saliva. The salivary secretion from two ticks (*A. americanum* and *A. maculatum*) was analyzed by a combination of 2D electrophoresis, Western-blot and MALDI-TOF (Madden et al., 2002). MALDI-TOF MS has been widely used for molecular weight determinations of purified proteins, such as tsetse thrombin inhibitor from *Glossina morsitans* (Cappello et al., 1998) or guamerin, inhibitor of serine proteases from *Hirudo nipponia* (Jung et al., 1995). Due to the absence of complete leech protein database, the construction of an ESTs (expressed sequence tags) database from *H. depressa* salivary complex was undertaken by our group (Faria et al., 2005). The proteomic and transcriptomic analysis are now being used to complement the protein identification (Valenzuela et al., 2002a,b, 2003).

In *Haementeria depressa*, two proteins were previously characterized: lefaxin, an inhibitor of factor Xa (Faria et al., 1999) and hementerin, a fibrinogenolytic protein and inhibitor of platelet aggregation (Chudzin-ski-Tavassi et al., 1998, 2003). In the present work, a crude extract of the salivary complex from *H. depressa* was investigated by 2D electrophoresis and by a preliminary proteomic approach. The aim of this study was to identify the main proteins expressed in this sample, which may have a biological role in feeding and digestion. The knowledge of saliva composition is of importance for the discovery of new pharmaceutical proteins.

## MATERIALS AND METHODS

### *Sample preparation and two-dimensional electrophoresis*

For this study, *Haementeria depressa* species were harvested in swamps from the South of Brazil and were maintained in an aquarium in the laboratory of Biophysics and Biochemistry at Butantan Institute (São Paulo, Brazil). In order to excise the salivary complexes, leeches not fed for 2–3 months and longer than 7 cm, were anesthetized with ether and dissected by a longitudinal incision on the dorsal midline. The salivary complexes, composed by anterior and posterior pairs of glands and proboscis, were removed, frozen, and stored at  $-80^{\circ}\text{C}$  (Kelen and Rosenfeld, 1975). The posterior suckers were also dissected for a comparative analysis.

Considering the difficulty of obtaining the saliva secretion, we analysed the whole salivary complex. Considering that leech proboscis has muscle proteins, a comparison of the posterior sucker proteins with those in the salivary complex extracts allowed the exclusion of muscular proteins. A pool of 50 salivary complexes and/or five posterior suckers were used for 2D electrophoresis analysis. Samples were ground in a mortar with liquid nitrogen and solubilized in rehydration solution containing 8M urea, 2% CHAPS, 0.5% ampholytes, 60 mM DTT. Cell debris were removed by centrifugation ( $10,000 \times g$  for 20 min at  $20^{\circ}\text{C}$ ). The analytical 2D gel (100  $\mu\text{g}$  of protein, determined by Bradford's method) or preparative 2D gel (800  $\mu\text{g}$  of protein) were prepared mixing the proteic sample in 350  $\mu\text{L}$  of rehydration solution, which were applied to an 18-cm immobilized linear gradient of pH 3–10 strip; and rehydrated overnight at  $20^{\circ}\text{C}$  with a constant voltage of 30 V using IPGphor<sup>®</sup> system (Amersham Biosciences, Sweden). IEF (isoelectrofocusing) was performed in three steps (0.5 kV for 1 h, 1 kV for 1 h, 8 kV for 4 h), reaching about 33 kVh.

After IEF, the strips were equilibrated with a solution of 6M urea containing 30% glycerol, 50 mM Tris-HCl (pH 8.8), 2% SDS, reduced with 65 mM DTT, alkylated with 135 mM iodoacetamide and directly applied on the top of a homogenous polyacrylamide gel (14% T, 2.6% C). The second dimension, SDS-PAGE, was performed at constant current (25 mA per gel, max 200 mA) at 8°C using a vertical system (Hoefer® DALT) (Amersham Biosciences, Sweden). Proteins from analytical gels were revealed by silver staining (using a protocol compatible with mass spectrometry analysis) (Schevchenko et al., 1996), and preparative gels were stained by Coomassie Blue. Image analysis was performed using the Image Master® software (Amersham Biosciences, Sweden). The reproducibility and pattern quality of each set of 2D gel was evaluated by conducting three independent experiments.

#### *In-gel proteolytic digestion*

The most abundant spots were selected for MS analysis, while some proteins involved in hemostasis described in literature were also used as guidelines for selective gel regions to be analysed. The gel pieces containing the selected spots were excised, transferred to 1.5 mL microtubes, and destained with a solution of 100 mM ammonium bicarbonate and 50 % acetonitrile. The gel pieces were digested in a buffer solution (50 mM ammonium bicarbonate, 5 mM CaCl<sub>2</sub>, and 12.5 ng/μL trypsin) for 45 minutes on ice and then incubated at 37°C for 12 h in the same solution, without trypsin (Schevchenko et al., 1996). The tryptic peptides were extracted from the gel pieces with 100 mM ammonium bicarbonate in 50% acetonitrile and concentrated by vacuum centrifugation until completely dried. Tryptic peptide fragments were desalted with Zip-tip C18 (Millipore, USA), before the MS analysis.

#### *Peptide mass fingerprinting (PMF) by MALDI-TOF MS*

Dried samples were solubilized in 0.5% TFA, 1 μL of peptide (corresponding to 1–10 pmol of protein) and 9 μL of matrix solution were homogeneously mixed and dried on the sample plate. The matrix solution consisted of 10 mg/mL α-cyano-4-hydroxycinnamic acid was solubilized in a solution of 50% acetonitrile and 0.5% TFA. The peptidic solutions were analysed on an ETTAN MALDI-TOF MS instrument (Amersham Biosciences, Sweden). Mass spectra were obtained in reflectron mode using an accelerating voltage of 20 kV and 150 ns delay extraction. Desorption and ionization of sample were performed using a nitrogen laser ( $\lambda = 337$  nm).

#### *Peptide sequencing by ESI Q-TOF MS/MS*

Dried samples were solubilized in 0.5% TFA. About 5 μL of sample were injected with a syringe in the electrospray ion source of the instrument. The experiments were performed on a Q-TOF ultima mass spectrometer (Micromass, UK), a hybrid-quadrupole-orthogonal time-of-flight tandem instrument operated under the control of the MassLynx® software (Micromass, UK). The protonated peptides were subjected to collision-induced dissociation with argon in the 15–45 eV collision energy range. Doubly charged peptides were fragmented. Peptide sequences were determined de novo with the assistance of MassLynx® software.

#### *Protein identification*

Proteins were identified by their position on the 2D gels, masses of fragments from trypsin digestion (PMF) and partial or full sequence information obtained by tandem analysis. The bioinformatics tools used for protein identification were as follows: TagIdent (([www.expasy.ch](http://www.expasy.ch))) for pI and MW matching; Mascot (([www.matrixscience.com](http://www.matrixscience.com))) for analysing the PMF data, BLASTp (([www.ncbi.nlm.nih.gov/BLAST](http://www.ncbi.nlm.nih.gov/BLAST))) and MS-BLAST (([www.dove.emblheidelberg.de/Blast2/msblast.html](http://www.dove.emblheidelberg.de/Blast2/msblast.html))) for sequence similarities. For these searches all the database available on each service were used. EST sequences from the salivary complex of *H. depressa* are available at GenBank (accession numbers from CN807028 to CN807918). A theoretical trypsin digestion (MS-Digest) of sequences translated from salivary complex of *H. depressa* ESTs was used for PMF analysis. The sequences obtained by ESI-Q-TOF MS were also searched against this EST database, which allowed to discriminate between leucine and isoleucine residues.

## SALIVARY COMPLEX FROM A HEMATOPHAGOUS LEECH

### *Biological activity by zymography with gelatin*

120  $\mu\text{g}$  of salivary complex was applied into 10% SDS-PAGE gel containing 0.1 mg/mL gelatin (Heunissen, and Dowdle, 1980). Electrophoresis was performed at 6 mA at 4°C. The gel was washed with 2.5% Triton X-100 for 30 min to remove SDS, then washed for three times with distilled water to remove Triton, stained with 0.1% Coomassie Blue (50% methanol, 10% acetic acid) and destained (15% methanol, 15% acetic acid). Clear zones of substrate lysis against a blue background stain indicated the presence of proteolytic enzymes.

### *Fibrinolytic activity by two-dimensional zymography*

Crude extract, 350  $\mu\text{g}$  of the salivary complex was applied to an immobilized dry-strip gel (linear gradient pH 3–10, 11 cm). The procedure used was the same as described above. However, the sample was rehydrated in a solution without DTT and the IEF was slower: 1 kV for 1 h, 2 kV for 2 h, 3 kV constant until reaching 16 kVh (Park et al., 2002). After the second dimension, the gel was washed with 2.5% Triton X-100 for 30 min to remove SDS and then washed for three times with distilled water to remove Tri-

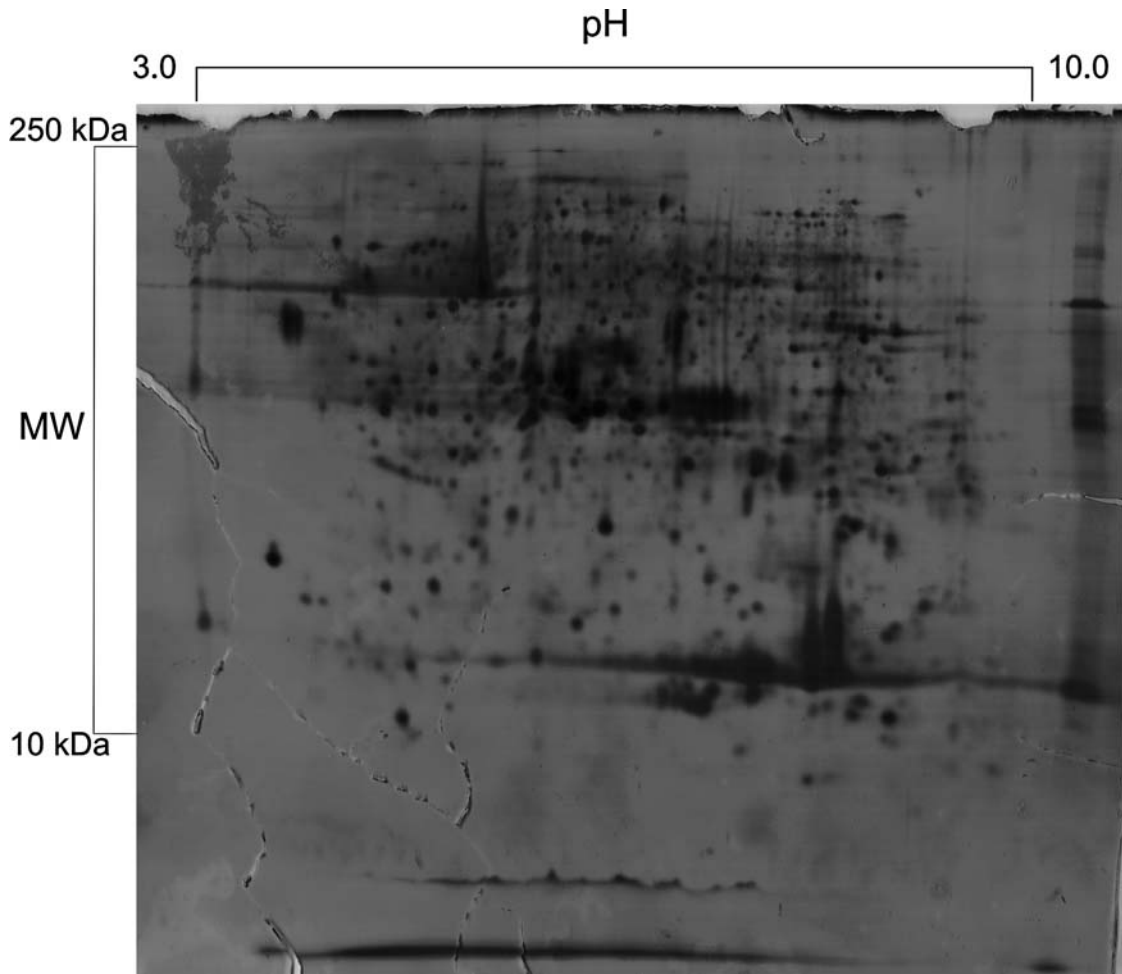

**FIG. 1.** Two-dimensional electrophoresis gel of salivary complex from *Haementeria depressa*. 100  $\mu\text{g}$  of protein were applied to an 18-cm linear immobilized gradient pH 3.0–10.0 strip. IEF was performed in IPGphor<sup>®</sup> and reached 33 kVh. SDS-PAGE 14% was performed in Hoefer<sup>®</sup> DALT. Proteins were detected by silver staining (352 total spots).

ton. So, the gel was applied on a fibrin-agarose polymer, which contained 1 mg/mL human fibrinogen in 50 mM Tris pH 7.5, 10 U/mL thrombin, 1 mM CaCl<sub>2</sub> and 1% agarose (Astrup and Permin, 1947). The gel was incubated overnight at 37°C, stained with Coomassie Blue, and destained.

## RESULTS

### *Analytical and preparative two-dimensional gels*

Proteins from the salivary complex and posterior sucker (muscular tissue) of *H. depressa* were analysed by the 2D gel electrophoresis technique. Two-dimensional gel of the salivary complex showed 352 total spots (Fig. 1) and the muscular tissue, 183 total spots (Fig. 2). In 2D gels of salivary complex and muscular extract, the majority of spots encompassed proteins with MWs of 10–105 kDa and pIs of 3.5–9.5. Successive and parallel experiments showed a reproducible pattern of protein spots. Comparative analysis of the 2D gel maps showed that 249 out of 352 total spots were exclusively from saliva, and the remaining 103 protein spots were common for both extracts (Fig. 3).

Once 2D gel pattern maps were established, the identification of spots by PMF and *de novo* sequencing using MALDI-TOF MS and MS/MS data was performed. *De novo* MS/MS sequencing required a larger sample even for a simple molecular mass determination, thus a higher amount of proteins was loaded on

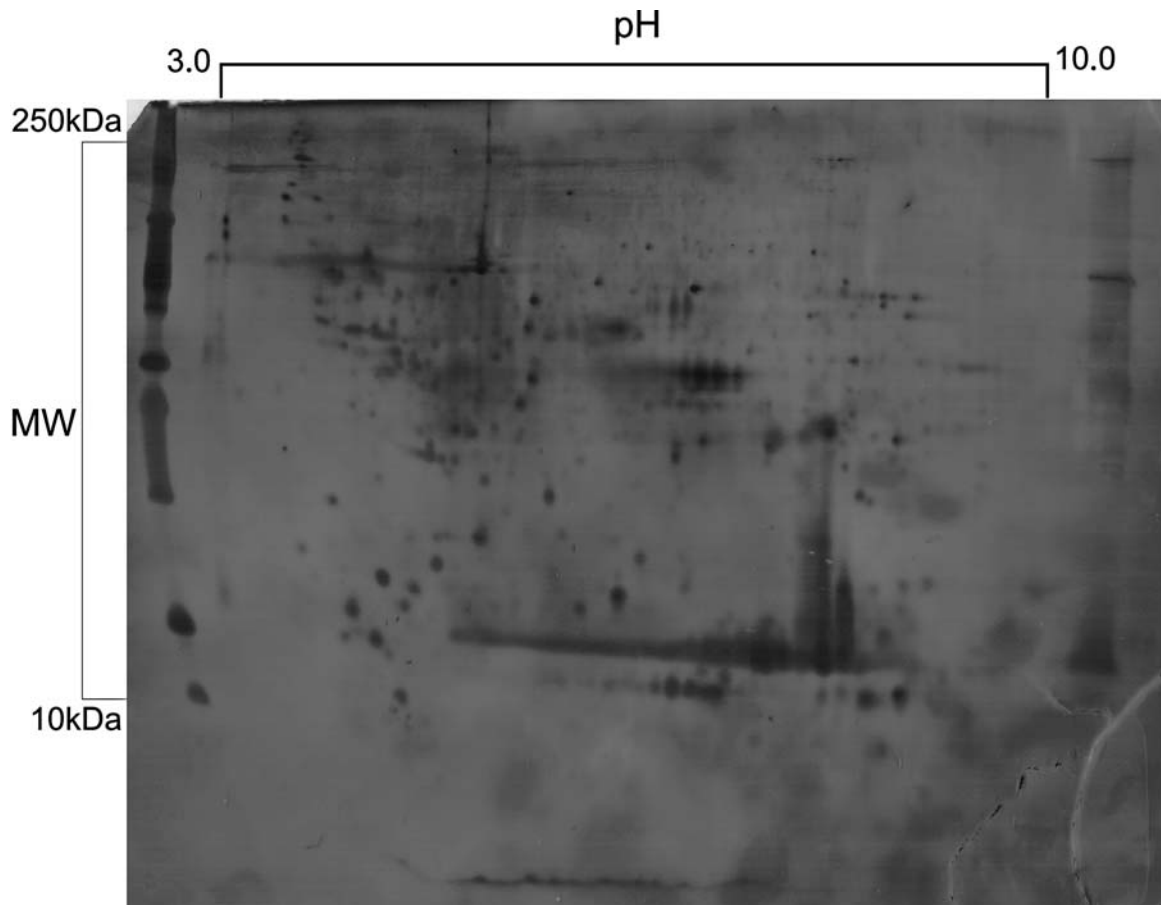

**FIG. 2.** Two-dimensional electrophoresis gel of muscular extract from *Haementeria depressa*. 100 µg of protein were applied to an 18-cm linear immobilized gradient pH 3.0–10.0 strip. IEF was performed in IPGphor® and reached 33 kVh. SDS-PAGE 14% was performed in Hoefer® DALT. Proteins were detected by silver staining (183 total spots).



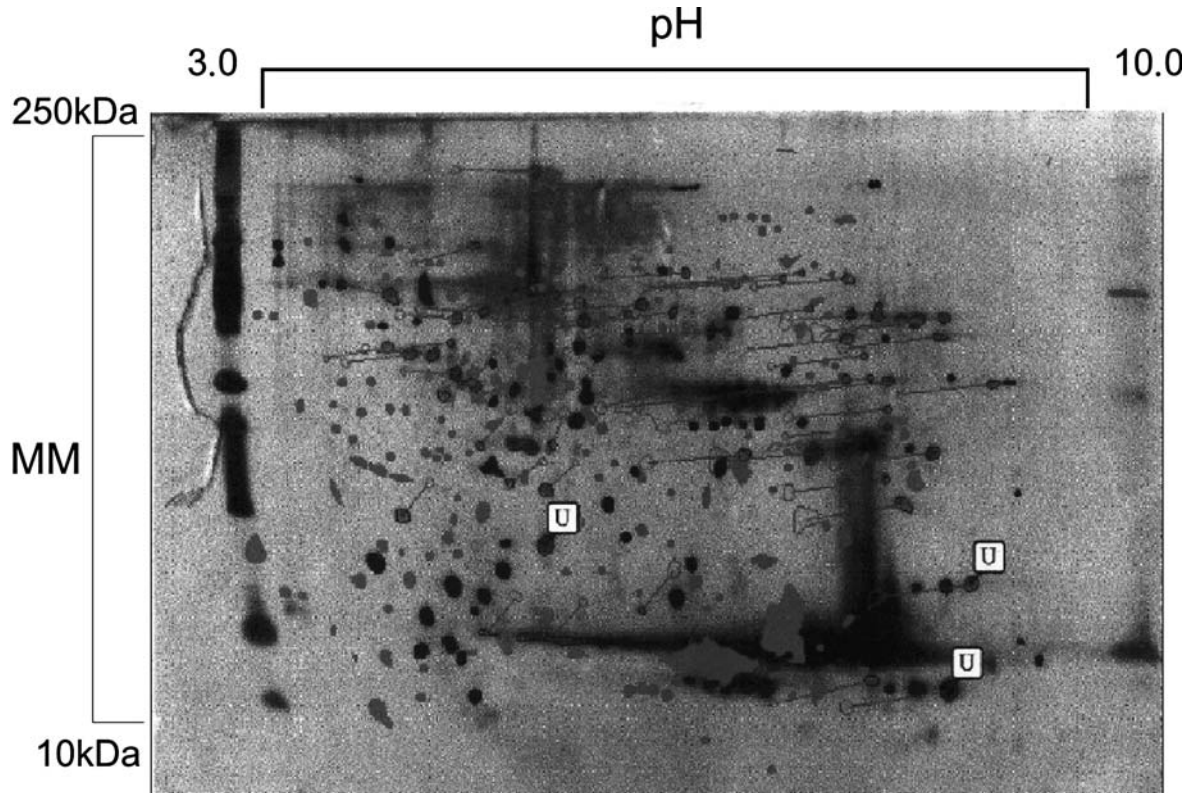

**FIG. 3.** Two-dimensional electrophoresis image matching analysis. Protein extracts from the salivary glands and the muscular tissue were compared. The gray spots (salivary glands proteins) and the black spots (muscular tissue proteins) were analyzed by the software Image Master<sup>®</sup>. Some common spots were matched manually (U); then, the other matches were done automatically.

2D gels preparations (800  $\mu\text{g}$  of protein). The salivary complex 2D gel showed 219 total spots, when Coomassie staining was used (Fig. 4).

#### *Identification of proteins from two-dimensional spots*

From 219 total spots of salivary complex from *H. depressa*, 10 of the most abundant spots were identified, supposing they could be correlated with the blood digestion or having an antihemostatic role. Spots 1 and 2 (Fig. 4) were both exclusively from saliva. PMF analysis of spot 1 (pI 3.5/MW 17 kDa) corresponded with LAPP (Q01747) and with a similar antiplatelet protein (HDEP0318s and HDEP0545s from *H. depressa* dbEST). Peptidic masses of spot 2 (pI 3.5/MW 16 kDa) corresponded to a similar antiplatelet protein (HDEP0059c and HDEP0344c from *H. depressa* dbEST).

For *de novo* sequencing analysis, doubly charged ions were fragmented, and the sequences/molecular ions (monoisotopic) were obtained for spots 1 and 2 (Table 1), after matching ESTs sequences to distinguish leucine from isoleucine. Spots 3, 4, and 5 were in the 14 kDa mass range and had pI between 6.7 and 8.5. They were very abundant in salivary complex and in muscle extracts. These three different spots were excised from gels of salivary complex and analysed. They represented series of related proteins, distinguished by their close pI (pIs 6.7; 7.1; 7.3, respectively), suggesting post-translational modifications. For these spots, the PMF analysis detected some common molecular ions:  $(M + H)^+ = 1311.6; 1455.6; 1854.9; 2562.2$ , and some exclusive molecular ions, such as:  $(M + H)^+ = 871.4; 978.5; 1010.6; 1243.7$  for spot 3;  $(M + H)^+ = 1263.5$  for spot 4 and  $(M + H)^+ = 1421.7; 1503.7; 1707.7; 2383.9$  for spot 5.

The PMF search of peptidic masses from spots 3, 4, and 5 matched with the theoretical trypsin digestion masses of translated sequence of HDEP0312s from the *H. depressa* ESTs, which is similar to myohe-

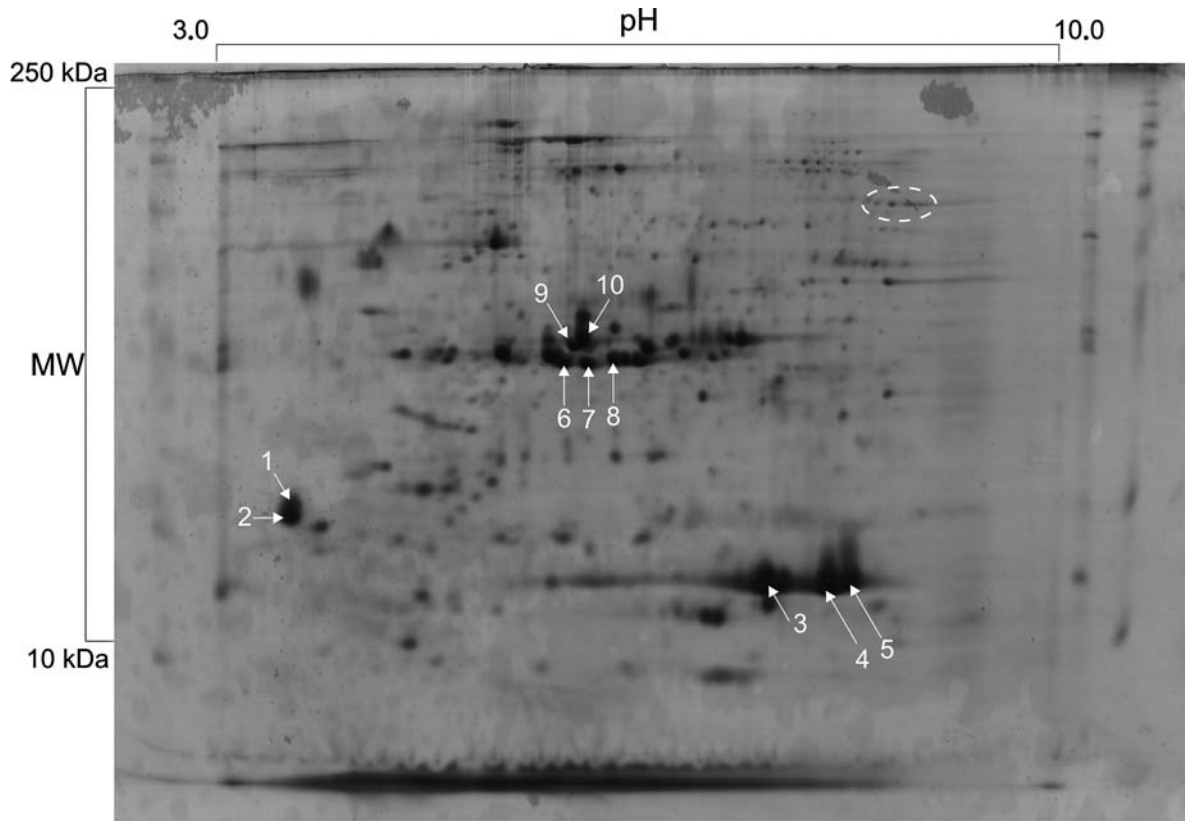

Spot	Identification	Molecular weight (kDa)	Isoelectric point
1	Antiplatelet	17	3.5
2	Antiplatelet	16	3.5
3	Myohemerythrin	14	6.7
4	Myohemerythrin	14	7.1
5	Myohemerythrin	14	7.3
6	Carbonic anhydrase	30	5.6
7	Carbonic anhydrase	30	5.8
8	Carbonic anhydrase	30	6.0
9	Carbonic anhydrase	30	5.5
10	Carbonic anhydrase	30	6.0

**FIG. 4.** Identification of proteins from two-dimensional electrophoresis gel of salivary complex from *Haementeria depressa* leech. 800  $\mu$ g of protein were applied to an 18-cm linear immobilized gradient pH 3.0–10.0 strip. IEF was performed in IPGphor<sup>®</sup> and reached 33 kVh. SDS-PAGE 14% was performed in Hoefer<sup>®</sup> DALT. Proteins were detected by Coomassie Blue staining (219 total spots). Dotted circle area corresponds to a fibrino(gen)olytic protein, probably hementerin.

merythrin from *T. tessulatum*. The sequences and molecular ions of tryptic peptides extracted from spot 3 obtained after fragmentation of the doubly charged ion are listed in Table 1. The hemerythrin domain (PS00550), H-F-X(2)-[ENQ]-X(2)-[LMF]-X(4)-[FY]-X(5-6)H-X(3)-[HR], which requires H, E, Q for iron ligands, where X represent any residue, is contained in HDEP0312s. The molecular ions 1311.6 and 1455.6

SALIVARY COMPLEX FROM A HEMATOPHAGOUS LEECH

**TABLE 1. MONOISOTOPIC MASSES AND SEQUENCES OBTAINED BY ESI Q-TOF MS FROM BIDIMENSIONAL SPOTS OF THE SALIVARY COMPLEX FROM *HAEMENTERIA DEPRESSA* LEECH**

<i>Spot number</i>	$(M + H)^+$ (observed)	$(M + 2H)^{2+}$ (observed)	<i>Sequences</i>
1	913.64	457.25	LPDNLLTK
	1243.65	622.24	TEFTSVDECR
	1653.73	827.36	ILQINTETNECYR
2	789.41		QQENDR
	851.55	426.28	FDESILK
	1358.81	679.91	CEVIQVNDSENKK
3	1375.85	688.43	CQVIQVNDSENKK
	871.38	436.21	FEEGMMK
	978.53	490.27	FDVPEPFK
6	1010.57	505.79	DWLVNHVK
	1243.64	622.33	GLFEAFFDLGK
	1276.76	638.85	SPSDAHALTHLK
7	1311.61	656.31	HFRFEEGMMK
	2321.1	1161.57	LHTDFEHDLESVHTPVSTEK
	486.34		ELPK
8	812.53	406.79	LVNELPK
	764.42	1527.72	ECEGNQSLPNLDVK
	772.93	1544.85	QCEGNQSLPNLDVK
9	530.39		NVLGK
	1159.77	580.37	VGNKNEELEK
	1196.81	598.91	KMVNEPHTLK
10	1337.78	669.39	QYDLELTNEGR
	1608.97	804.99	MVLSLSQEQLDAFK
	476.32		QSNK
11	1275.75	638.38	LADTDNEELQK
	706.51	353.76	FVSLLK
	929.56	465.29	VGQTESDPP
12	1055.65	528.33	RPVQDAVDR
	1233.75	617.39	ESLSLSQTQLK
	1283.74	642.40	LNLPTK
13	1375.77	688.41	LNEGTELELQK
	1443.80	722.42	LSYDFELTENGR
	973.58	487.32	VSNVLSVAGK
14	1018.56	509.76	EVSPDNVMK
	1037.50	519.26	SYYQYEGK
	1073.63	537.31	QDELNEVVK
15	1101.65	551.34	VSNVLSVAGKK
	1187.53	594.27	WGEMYWCR

from spots 3, 4 and 5 seem to belong to this domain. Spots 6, 7, 8, 9, and 10 were very abundant spots with MW of approximately 30 kDa and pI ranging from 5.5 to 6.2 in salivary complex 2D gels. These spots were not found in the same region of 2D gel of muscular extract. Five of them were analyzed further. The PMF analysis detected the following  $(M + H)^+$  molecular ions: 486.3; 812.5; 772.9 for spot 6; 530.3; 1159.7; 1196.8; 1337.7; 1737.1 for spot 7; 476.3; 1275.7 for spot 8; 706.5; 1233.7; 1375.7 for spot 9; 973.5; 1018.5; 1037.5; 1073.6; 1187.5 for spot 10.

At the first glance, the peptidic fragments of spots 6, 7, 8, 9, and 10 did not show any significant correlation among their masses and/or their sequences (Table 1). However, the molecular ion 568.1 was detected in spots 6, 7, 8, and 10; the ion 1173.7 was detected in spots 6 and 7; and the ions 1608.9 and 2125.2



were detected in spots 7 and 10. Using the MS-BLAST search, a significant similarity was found for the sequences VGNKNEELEK (1159.7) and MVLSSLSEQLDAFKK (1737.1) obtained by MS/MS *de novo* sequencing from spot 7 and carbonic anhydrase from the *Bacillus halodurans* bacterium. Identification of these spots was possible due to correlation with translated sequences from leech ESTs. Peptidic fragments' sequences were associated with clusters (HDEP0020c, HDEP0030c, HDEP0065c, HDEP0088c, HDEP0123s, HDEP0442s, HDEP0451s, HDEP0494s, HDEP0500s, HDEP0501s) that showed a carbonic anhydrase-type domain (PS00162, for eukaryotes).

#### *Identification of proteins by biological activity*

Hementerin is a metalloprotease with fibrinogenolytic properties (Chudzinski-Tavassi et al., 1998) and antiplatelet action, via nitridergic pathway (Chudzinski-Tavassi et al., 2003). A 2D zymography was done from salivary complex extract and this fibrinolytic assay showed only one lytic region corresponding to a protein of ~80 kDa and pI ~8.0–9.0 in the 2D map, hementerin (Fig. 4, dotted circle). A proteolytic activity on gelatin was detected in the salivary complex extract by zymography. A lytic area corresponding with a unique protein of about 45 kDa was observed as a weak band in SDS-PAGE.

## DISCUSSION

In this work, 25 spots were analysed, which corresponded to 11% of the total protein that can be detected on a 2D gel of the salivary complex of *Haementeria depressa* leech. First, antiplatelet protein, myohemerythrin and carbonic anhydrase were identified by 2D and MS/MS sequencing. Since the leech possesses a complex protein mixture for blood processing and digestion, the expressed proteins identified by proteomic analysis seem to be the most predominant ones. Therefore, these proteins should be correlated to the host hemostatic mechanism.

The localization of spots 1 and 2 on 2D map was compatible with an antiplatelet protein (LAPP) from the leech *H. officinalis* (pI 4.0, MW ~14 kDa; Q01747) (Connolly et al., 1992). Sequences obtained from spots 1 and 2 by tandem analysis were aligned with their correlated sequences (LAPP from *H. officinalis*, and HDEP0344c, HDEP0059c, HDEP0318s, and HDEP0545s from *H. depressa* ESTs) (Fig. 5). From complete sequences of the antiplatelet protein it is possible to estimate the coverage of fragments sequenced by ESI-Q-TOF MS. Spot 1 had 45 residues from 150 total residues (HDEP0318s), identified by mass spectrometry (30% of coverage). For spot 2, 35 residues were identified by mass spectrometry, corresponding to 25% of HDEP0059c. The tryptic fragments of these acidic spots (pI 3.5) did not have an efficient protonation in the positive mode of the mass spectrometer.

From translated sequences of ESTs, 8 clusters were identified as an antiplatelet protein, showing a pI range from 3.8 to 4.4 and MW range from 10 to 15 kDa. Thus, we can suggest that the sequences analysed from spots 1 and 2 and clusters HDEP0059c, HDEP0318s, HDEP0344c, and HDEP0545s are isoforms. Two isoforms of the antiplatelet protein from *H. depressa* have a high similarity with LAPP (HDEP0318s = 86%; HDEP0545s = 82%) and the most important is that they share the same sequences and positions necessary for the secondary structure configuration, which was determined by crystallographic studies of LAPP (Huizinga et al., 2001).

Once the antiplatelet proteins from *H. depressa* will be completely sequenced, their expression and their biological activity test will be carried out. It is expected that they can block the collagen-mediated platelet adhesion and aggregation, inhibiting the binding of vWF to collagen, like LAPP does (Depraetere et al., 1999). These properties of LAPP are in contrast with decorsin (Seymour et al., 1990) and ornatin (Mazur et al., 1991), which are antagonists of the GPIIb-IIIa receptor, antiplatelet proteins isolated from the saliva of the leeches *M. decora* and *P. ornata*, respectively.

Spots 3, 4 and 5 corresponded to the 2D position of myohemerythrin from *T. tessulatum* (pI 5.0 and MW 14119 Da), which has also been described as highly expressed protein (Coutte et al., 2001). Myohemerythrin from *H. depressa* and from *T. tessulatum* shares 47% of identity. Their sequences were aligned and the peptidic fragments from spot 3 were localized in the complete sequence deduced from EST database (Fig. 6). From a total of 134 residues for HDEP0312s, 102 residues were identified by mass spectrometry

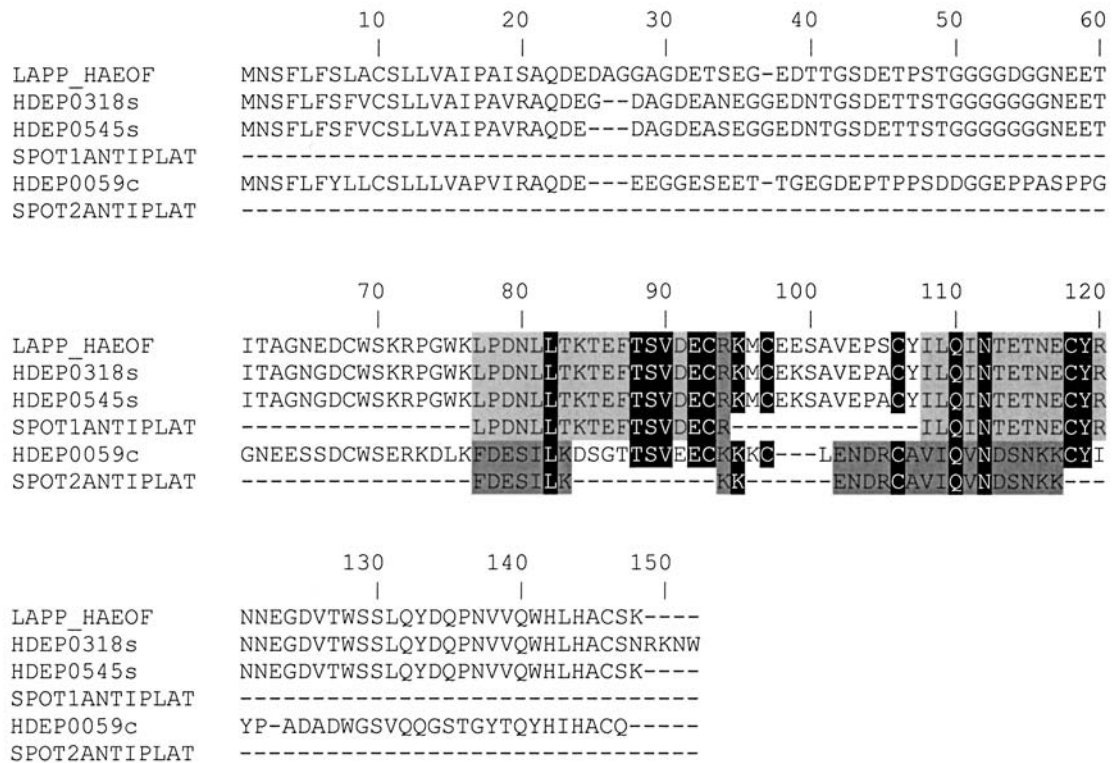

**FIG. 5.** Alignment of proteins identified as antiplatelet protein. The sequences of proteins translated from leech dbESTs (clusters HDEP0059c, HDEP0318s, HDEP0344c, and HDEP 0545s), sequences obtained by mass spectrometry analysis of tryptic fragments from spots 1 and 2 from salivary complex of *Haementeria depressa*, and also the sequence of LAPP (Swiss Prot: Q01747) from *H. officinalis* were aligned by CLUSTALW. Identical residues in the tryptic fragments, the clusters, and LAPP-HAEOF are boxed in black. The identity of each spot and its corresponding sequence from EST cluster is shaded in light or dark gray.

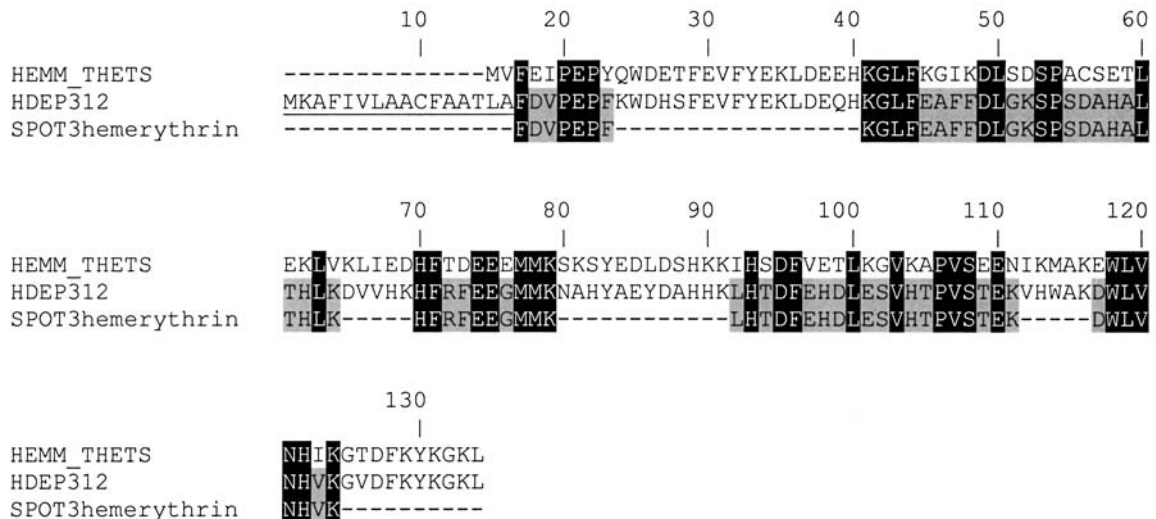

**FIG. 6.** Alignment of proteins identified as myohemerythrin. The sequence of protein translated from leech dbEST (cluster HDEP0312s), containing the signal peptide (underlined), the sequence obtained by mass spectrometry analysis of tryptic fragments from spot 3 from salivary complex of *Haementeria depressa* and also the sequence of myohemerythrin (Swiss Prot: Q9GYZ9) from *T. tessulatum* (HEMM-THETS) were aligned by CLUSTALW. Identical residues in all the three sequences are shaded with black boxes, and residues identical to the spot and the cluster are shaded with gray boxes.

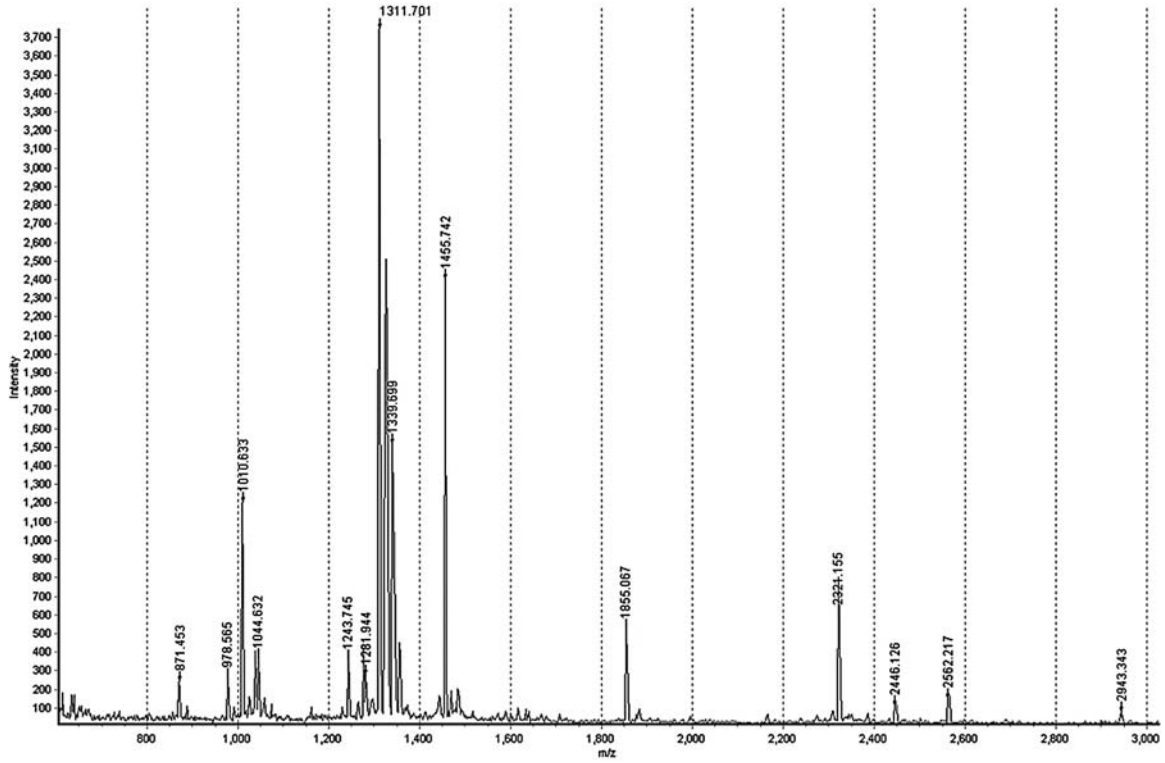

Spot 3

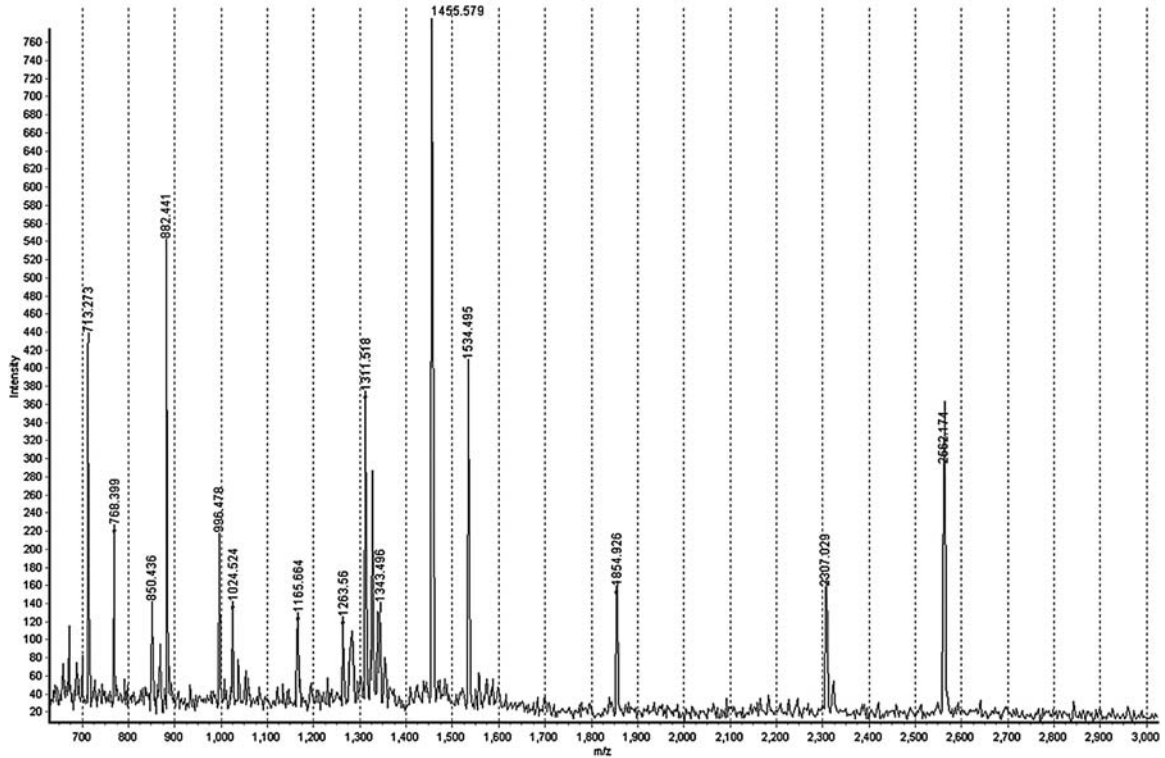

Spot 4

**FIG. 7.** PMF analysis of tryptic digestion. Tryptic digestion in-gel from spots 3, 4, and 5 of complex salivary from *Haementeria depressa* were analyzed by MALDI-TOF MS, which corresponds to myohemerythrin.

SALIVARY COMPLEX FROM A HEMATOPHAGOUS LEECH

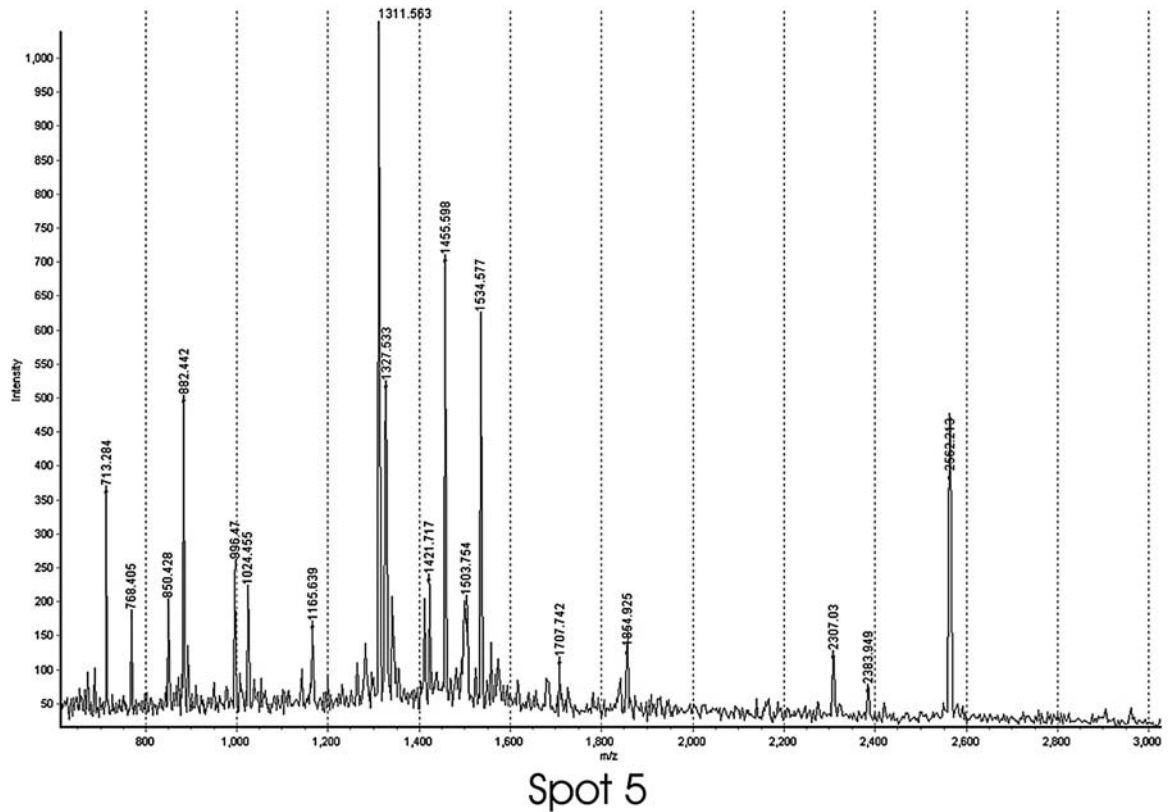

FIG. 7. Continued.

(76% of coverage), considering that spot 3 has a neutral composition of residues (pI 6.7) that could be analysed. The first 16 residues from HDEP0312s constitute the signal peptide that is cleaved before the secretion of mature protein (spot 3).

In the leech EST database, 12 clusters corresponding to myohemerythrin, have an hypothetical pI range from 5.0 to 7.9 and MW from 10.9 to 13.9 kDa. These are possible isoforms, from which protein spots 3, 4, and 5 came from. A comparative PMF analysis of spots 3, 4, and 5 suggests that post-translational modification was observed in this group of proteins (Fig. 7). For instance, hemerythrins are not glycosylated, as described in literature (Coutte et al., 2001; Baert et al., 1992), but they are susceptible to phosphorylation. The detection of the ion 1534.4 in the tryptic digest of spots 4 and 5, but not in spot 3 could represent a mass increment of approximately 80 Da on the ion 1455.5, which could correspond to a O- or N-phosphorylation or to a O-sulphation. This may explain the differential pIs of protein spots 3, 4, and 5. Nevertheless, the characteristic metastable ion associated with phosphoserine or phosphothreonine was not observed in the PMF spectrum, but it is possible to be a phosphotyrosine compound. This fact is in agreement with the hypothetical phosphorylation of the cluster HDEP0312s, which has two tyrosine residues susceptible to a phosphorylation; besides the 3 and 2 sites predicted for serine and threonine phosphorylation, respectively.

Hemerythrin is a multisubunit non-heme, oxygen-binding protein found in the vascular system and in the coelomic fluid of invertebrates, such as annelids (Coutte et al., 2001). On the other hand, myohemerythrins are analogues of hemerythrins found in muscle tissues, usually present as monomers. Organisms that express more than one type of hemerythrin can exhibit functional diversity as a result of evolution (Terwilliger, 1998). For example, ovohemerythrin, a yolk protein is a major component of mature oocytes of the *T. testulatum* leech, and it plays a role in the detoxification of free iron after a blood meal (Baert et al., 1992). Also, antibacterial property of hemerythrin was found in *N. diversicolor* (Deloffre et al., 2003). In addition, lefaxin, an inhibitor of FXa, previously characterized (Faria et al., 1999), shares 68% of similarity with my-



ohemerythrin from *N. diversicolor* and 44% with Prolixin S, an anticoagulant from *R. prolixus*. It would be interesting to biochemically characterize the hemerythrins isoforms identified in the salivary complex by proteomic analysis.

The localization of spots 6, 7, 8, 9, and 10 correspond in terms of MW and pI to carbonic anhydrase from the midgut of larval of *Aedes aegypti* hematophagous (pI 6.1; MW 32.7 kDa) (Corena et al., 2002). The detection of multiple spots on 2D gel of salivary complex of *H. depressa* indicates the presence of isoforms. Sequences of spots 6, 7, 8, 9, and 10 analysed by mass spectrometry matched to different carbonic anhydrase clusters from leech ESTs database. Nineteen clusters were identified in leech ESTs database, that match with the MS data obtained.

Carbonic anhydrase VI are secreted proteins present in saliva (Kivelä et al., 1999). Carbonic anhydrases participate in the maintenance of pH homeostasis in various tissues and biological fluids, catalysing the following reversible reaction:  $\text{CO}_2 + \text{H}_2\text{O} \leftrightarrow \text{HCO}_3^- + \text{H}^+$ . Here, for the first time, carbonic anhydrases isoforms are identified in the salivary complex of a leech using proteomic and transcriptomic analysis.

Hementerin was located on the 2D gel by fibrin-SDS/PAGE. As previously known, hementerin is the only protein having fibrinolytic activity in the salivary complex of *H. depressa*. Our efforts to identify hementerin by MS were unsuccessful until now. By loading proteins from the crude extract of the salivary complex of *H. depressa* in gelatin-SDS-PAGE, a weak band was detected. Unfortunately, this collagenolytic enzyme was not detected on gelatin-2D gel. However, a protein of ~50 kDa was described in *H. medicinalis* as a leech collagenase (mammalian type) (Rigbi et al., 1987). Then, evaluating the zymographic assays, it means that the presence of proteolytic enzymes in the saliva might be related to increasing the tissue permeability and consequently, favouring blood ingestion.

## CONCLUSION

This work presents for the first time the combination of proteomic and transcriptomic analysis of salivary complex from a leech (*Haementeria depressa*). The two-dimensional map of salivary complex and muscular tissue showed 352 and 183 total spots, respectively, detected by silver staining, 249 of which were exclusive from saliva. The majority of proteins from both extracts show pI range from 3.5 to 9.5 and MW from 10 to 105 kDa. The salivary complexes were dissected from leeches that were not fed for 2–3 months. In this case, leeches secrete proteins that facilitate the blood metabolism. Thus, the protein groups identified so far, may play an antihemostatic role. Our proteomic analyses allowed to identify isoforms of antiplatelet proteins (~16–17 kDa, pI 3.5); myohemerythrin (~14kDa, pI 6.7–7.3) and carbonic anhydrase (~30 kDa, pI 5.5–6.0). Antiplatelet proteins, similar to LAPP, might be able to avoid platelet aggregation; myohemerythrin, besides its ability as oxygen-carrier, has similarity with lefaxin and prolixin S, which are inhibitors of coagulation process; carbonic anhydrase neutralizes the acidic condition in digestive system. A bidimensional zymography allowed localizing hementerin in 2D gel map, having a fibrinogenolytic activity, as previously characterized. A protein degrading gelatin was also identified by zymography, probably a collagenase.

The identification of proteins by bidimensional positioning, PMF analysis, tandem mass sequencing analysis and comparison with the leech ESTs database were essential for the identification of leech proteins. Furthermore, a limitation of MS/MS sequencing analysis is to distinguish among isobaric residues, but these ambiguous sequences were confirmed with the sequences translated from the ESTs. The proteins identified by bidimensional electrophoresis and mass spectrometry corresponded with expressed forms of transcripts from genome and it is valuable in describing post-translational modifications.

## ACKNOWLEDGMENTS

We are grateful to Dr. Álvaro Rossan de Brandão Prieto da Silva from Laboratory of Molecular Toxicology (Butantan Institute) for bioinformatic assistance; and to Luciano Barbosa and Delfino Beck Barbosa



## SALIVARY COMPLEX FROM A HEMATOPHAGOUS LEECH

(Fazenda Panorama, Camaquã, RS), Noronha and Silvia (Miracatu, SP) for catching the leeches. The grants were provided by Fundação de Amparo à Pesquisa do Estado de São Paulo (FAPESP) and CAT/CEPID (Butantan Institute), and the fellowship was also provided by FAPESP (Maria Esther Ricci da Silva, 99/12087-4).

## REFERENCES

- ASTRUP, T., and PERMIN, P.M. (1947). Fibrinolysis in animal organism. *Nature* **159**, 778.
- BAERT, J.L., BRITEL, M., SAUTIERE, P., et al. (1992). Ovohemerythrin, a major 14-kDa yolk protein distinct from vitellogenin in leech. *Eur J Biochem* **209**, 563–569.
- CAPPELLO, M., LI, S., CHEN, X., et al. (1998). Tsetse thrombin inhibitor: blood meal-induced expression of an anticoagulant in salivary glands and gut tissue of *Glossina morsitans morsitans*. *Proc Natl Acad Sci USA* **95**, 14290–14295.
- CHOPIN, V., SALZET, M., BAERT, J.L., et al. (2000). Therostasin, a novel clotting factor Xa inhibitor from the rhynchobdellid leech, *Theromyzon tessulatum*. *J Biol Chem* **275**, 32701–32707.
- CHUDZINSKI-TAVASSI, A.M., KELEN, E.M.A., PAULA ROSA, A.P., et al. (1998). Fibrino(geno)lytic properties of a purified hementerin, metalloproteinase from the leech *Haementeria depressa*. *Thromb Haemost* **80**, 155–160.
- CHUDZINSKI-TAVASSI, A.M., BERMEJO, E., ROSENSTEIN, R.E., et al. (2003). A nitridergic platelet pathway activation by hementerin, a metalloprotease from *Haementeria depressa* leech. *Biol Chem* **384**, 1333–1339.
- CONDRA, C., NUTT, E., PETROSKI, C.J., et al. (1989). Isolation and structural characterization of a potent inhibitor of coagulation factor Xa from the leech *Haementeria ghilianii*. *Thromb Haemost* **61**, 437–441.
- CONNOLLY, T.M., JACOBS, J.W., and CONDRA, C. (1992). An inhibitor of collagen-stimulated platelet activation from the salivary glands of the *Haementeria officinalis* leech—identification, isolation and characterization. *J Biol Chem* **267**, 6893–6898.
- CORENA, M.P., SERON, T.J., LEHMAN, H.K., et al. (2002). Carbonic anhydrase in the midgut of larval *Aedes aegypti*: cloning, localization and inhibition. *J Exp Biol* **205**, 591–602.
- COUTTE, L., SLOMIANNY, M.C., MALECHA, J., et al. (2001). Cloning and expression analysis of a cDNA that encodes a leech Hemerythrin. *Biochim Biophys Acta* **1518**, 282–286.
- DE EGUILEOR, M., TETTAMANTI, G., GRIMALDI, A., et al. (2003). Leeches: immune response, angiogenesis and biomedical applications. *Curr Pharm Des* **9**, 133–147.
- DELOFFRE, L., SALZET, B., VIEAU, D., et al. (2003). Antibacterial properties of hemerythrin of the sand worm *Nereis diversicolor*. *Neuroendocrinol Lett* **24**, 39–45.
- DEPRAETERE, H., KEREEKES, A., and DECKMYN, H. (1999). The collagen-binding leech products rLAPP and calin prevent both von Willebrand factor and  $\alpha 2\beta 1$  (GPIIb/IIIa)-I-domain binding to collagen in a different manner. *Thromb Haemost* **82**, 1160–1163.
- ELDOR, A., OREVI, M., and RIGBI, M. (1996). The role of the leech in medical therapeutics. *Blood Rev* **10**, 201–209.
- FARIA, F., KELEN, E.M.A., SAMPAIO, C.A.M., et al. (1999). A new factor Xa inhibitor (lefaxin) from the *Haementeria depressa* leech. *Thromb Haemost* **82**, 1469–1473.
- FARIA, F., JUNQUEIRA-DE-AZEVEDO, I.L.M., HO, P.L., et al. (2005). Gene expression in the salivary complexes from *Haementeria depressa* leech through the generation of expressed sequence tags (ESTs). *Gene* **349**, 173–185.
- GARCIA-GIL, M., BOTTAI, D., CANNIZZARO, M., et al. (1991). Effect of phorbol ester on protein phosphorylation in the central nervous system of the leech *Hirudo medicinalis*: a two-dimensional electrophoretic analysis. *Comp Biochem Physiol* **B99**, 859–864.
- GYGI, S.P., CORTHALS, G.L., ZHANG, Y., et al. (2000). Evaluation of two-dimensional gel electrophoresis-based proteome analysis technology. *Proc Natl Acad Sci USA* **97**, 9390–9395.
- HAYCRAFT, J.B. (1884). Ueber die einwirkung eines secretes des officinellen blutegels auf die gerinnbarkeit des blutes. *Arch Exp Pathol Pharmacol* **18**, 209–217.
- HEUNSSSEN, C., and DOWDLE, E.B. (1980). Electrophoretic analysis of plasminogen activators in polyacrilamide gels containing sodium dodecyl sulfate and copolymerized substrates. *Anal Biochem* **102**, 196–202.
- HUIZINGA, E.G., SCHOUTEN, A., CONNOLLY, T.M., et al. (2001). The structure of leech antiplatelet protein, an inhibitor of haemostasis. *Acta Cryst* **D57**, 1071–1078.
- JUNG, H.I., KIM, S.I., HA, K.S., et al. (1995). Isolation and characterization of guamerin, a new human leukocyte elastase inhibitor from *Hirudo nipponia*. *J Biol Chem* **270**, 13879–13884.
- JUNGBLUT, P., and THIEDE, B. (1997). Protein identification from 2DE gels by MALDI-TOF mass spectrometry. *Mass Spectrom Rev* **16**, 145–162.

- KELEN, E.M.A., and ROSENFELD, G. (1975). Fibrinogenolytic substance (Hementerin) of brazilian blood-sucking leeches (*Haementeria lutzi* Pinto 1920). *Haemostasis* **4**, 51–64.
- KIVELÄ, J., PARKKILA, S., PARKKILA, A.K., et al. (1999). Salivary carbonic anhydrase isoenzyme VI. *J Physiol* **520**, 315–320.
- MADDEN, R.D., SAUER, J.R., and DILLWITH, J.W. (2002). A proteomics approach to characterizing tick salivary secretions. *Exp Appl Acarol* **28**, 77–87.
- MAZUR, P., HENZEL, W.J., SEYMOUR, J.L., et al. (1991). Ornatin: potent glycoprotein IIb–IIIa antagonists and platelet aggregation inhibitors from the leech *Placobdella ornate*. *Eur J Biochem* **202**, 1073–1082.
- NICHOLLS, J.G., and HERNANDEZ, U. (1989). Growth and synapse formation by identified leech neurons in culture: a review. *Q J Exp Physiol* **74**(7), 965–973.
- NUTT, E., GASIC, T., RODKEY, J., et al. (1988). The amino acid sequence of antistasin. A potent inhibitor of factor Xa reveals a repeated internal structure. *J Biol Chem* **263**, 10162–10167.
- PARK, S.G., KHO, C.W., CHO, S., et al. (2002). A functional proteomic analysis of secreted fibrinolytic enzymes from *Bacillus subtilis* 168 using a combined method of two-dimensional gel electrophoresis and zymography. *Proteomics* **2**, 206–211.
- RIGBI, M., LEVY, H., IRAQI, F., et al. (1987). The saliva of the medicinal leech *Hirudo medicinalis*—biochemical characterization of the high molecular weight fraction. *Comp Biochem Physiol* **B87**, 567–573.
- SALZET, M., CHOPIN, V., BAERT, J.L., et al. (2000). Theromin, a novel leech thrombin inhibitor. *J Biol Chem* **275**, 30774–30780.
- SAWDESH, J.K., HUANG, L.Y., and BUDZYNSKI, A.Z. (1990). Purification and characterization of hementin, a fibrinogenolytic protease from the leech *Haementeria ghilianii*. *J Chromatogr* **502**, 359–369.
- SCHEVCHENKO, A., WILM, M., VORM, O., et al. (1996). Mass Spectrometry sequencing of proteins from silver-stained polyacrylamide gels. *Anal Chem* **68**, 850–858.
- SEYMOUR, J.L., HENZEL, W.J., NEVINS, B., et al. (1990). Decorsin: a potent glycoprotein IIb–IIIa antagonist and platelet aggregation inhibitor from the leech *Macrobodella decora*. *J Biol Chem* **265**, 10143–10147.
- STRUBE, K.H., KROGER, B., BIALOJAN, S., et al. (1993). Isolation, sequence analysis and cloning of haemadin—an anticoagulant peptide from the indian leech. *J Biol Chem* **266**, 8590–8595.
- TERWILLIGER, N.B. (1998). Functional adaptations of oxygen-transport proteins. *J Exp Biol* **201**, 1085–1098.
- VALENZUELA, J.G., FRANCISCHETTI, I.M.B., PHAM, V.M., et al. (2002a). Exploring the sialome of the tick *Ixodes scapularis*. *J Exp Biol* **205**, 2843–2864.
- VALENZUELA, J.G., PHAM, V.M., GARFIELD, M.K., et al. (2002b). Towards a description of the sialome of the adult female mosquito *Aedes aegypti*. *Insect Biochem Mol Biol* **32**, 1101–1122.
- VALENZUELA, J.G., FRANCISCHETTI, I.M.B., PHAM, V.M., et al. (2003). Exploring the salivary gland transcriptome and proteome of the *Anopheles stephensi* mosquito. *Insect Biochem Mol Biol* **33**, 717–732.
- WHITAKER, I.S., IZADI, D., OLIVER, D.W., et al. (2004). *Hirudo Medicinalis* and the plastic surgeon. *Br J Plast Surg* **57**, 348–353.

Address reprint requests to:

Dr. Ana Marisa Chudzinski-Tavassi  
 Laboratory of Biochemistry and Biophysics  
 Butantan Institute  
 Avenida Vital Brazil, 1500  
 CEP 05503-900  
 São Paulo, SP, Brazil

E-mail: amchudzinski@butantan.gov.br