

VALUE ENGINEERING REPORT

SR 142 Widening & Bridge Reconstruction
STP00-1418-00(003), PI No 242230
Newton County

September 9, 2010

OWNER AND DESIGN TEAM:



Georgia Department of Transportation
600 West Peachtree Street
Atlanta, GA 30308

VALUE ENGINEERING CONSULTANT:



MACTEC Engineering and Consulting, Inc.
3200 Town Point Drive NW, Suite 100
Kennesaw, GA 30144

TABLE OF CONTENTS

VALUE ENGINEERING STUDY

SR 142 Widening & Bridge Reconstruction
STP00-1418-00(003), PI No 242230
Newton County

Executive Summary	1
Introduction.....	1
Considerations.....	1
Results Obtained	2
Recommendation Highlights	3
Design Considerations	5
Summary of Potential Cost Savings	6
Study Identification.....	8
VE Team Members.....	8
Project Description.....	8
Conditions/Constraints.....	8
Project Briefing.....	9
Project Vicinity Map – Figure 1	19
Project Sketch Map – Figure 2.....	11
Value Engineering Recommendations.....	12
Appendix	
Sources.....	54
Cost Model/Distribution	55
Fast Diagram.....	56
Function Analysis	57
Creative Ideas/Idea Evaluation	61

EXECUTIVE SUMMARY

Executive Summary

VALUE ENGINEERING STUDY

STP00-1418-00(003), PI No 242230
SR 142 Widening & Bridge Reconstruction
August 23-26, 2010

Introduction

This report presents the results of a value engineering (VE) study conducted on the proposed design for widening and reconstructing SR 142 from the CSX Railroad crossing to just north of the American Way / Sims Chapel Road intersection. The project will also widen Alcovy Road from Harland Drive to just north of the Avenue of Champions. State Route 142 will be widened to a four-lane divided roadway with a 20-foot raised median and 10-foot (6 ½-foot paved) outside shoulders. Alcovy Road is being widened to a four-lane urban roadway section with a 20-foot raised median south of SR 142 and to a four-lane divided roadway with a 20-foot raised median and 10-foot (6 ½-foot paved) outside shoulders north of SR 142. Both roadway typical sections will provide for bike lanes. The existing SR 142 Bridge over the CSX Railroad is being replaced with a new longer and wider structure. This project will also lower a short section of SR 142 in front of the Covington Municipal Airport.

Major contract work items include asphalt pavement, roadway grading, bridge replacement, roadway drainage, erosion control, and curb and gutter construction. The total estimated project cost including right-of-way (R/W) is \$15.4 million. The project is in the preliminary design stage and R/W appraisals have been authorized. The study took place August 23-26, 2010, at the Georgia DOT Headquarters Office, using a four person VE team.

This report presents the Team's recommendations and all back-up information for consideration by the decision-makers. This **Executive Summary** includes a brief description of each recommendation. The **Study Identification** section contains information about the project and the team. The **Recommendations** section presents a more detailed description and support information about each recommendation. The **Appendix** section includes a complete record of the Team's activities and findings. The reader is encouraged to review all sections of the report in order to obtain a complete understanding of the VE process.

Considerations

The VE team was presented with several constraints to consider when developing their recommendations. The constraints were; do not increase the project's impact on the Bridgestone Sporting Goods property, do not increase the project's impacts to local wetlands, and provide bike lanes on both SR 142 and Alcovy Road.

Current project status: The Project Concept Report has been approved and preliminary design is underway. A Categorical Exclusion was approved in 2000. Right-of-way acquisition is underway and the project has a scheduled letting date of December 2011.

Results Obtained

The VE team focused their efforts on the high cost items of the project. Through the use of functional analysis and “brain storming” techniques, the team generated 28 ideas with 16 being identified for additional evaluation as possible recommendations or design suggestions. The VE team developed six independent recommendations, one alternative recommendation, and two design considerations. Implementation of the six independent recommendations has the potential to reduce the project cost by approximately \$3.053 million. A detailed write-up of each recommendation and design consideration is contained in the respective section of this report. A summary of the recommendations and design considerations follows.

Recommendation Highlights

Idea A-3: Reduce and / or Eliminate the Sediment Basins due to high cost of R/W.

The original concept proposes to install several sediment basins along the project to provide for sediment storage requirements.

This recommendation proposes to remove the sediment basins and install additional ditch checks to provide for required sediment storage. While sediment basins provide optimal sediment storage, they are not practical in areas with high R/W costs. Additional ditch checks can be installed to offset the loss of sediment storage provided by the basins.

The total potential savings if accepted is \$317,000

Idea B-2: Reduce the Alcovy Road typical section width north of SR 142.

The current design proposes to extend the four-lane widening of Alcovy Road to the Avenue of Champions.

This recommendation would reduce the length of the project along Alcovy Road by ending the four-lane widening at the entrance to the Newton County Enforcement Center and tying into the existing two lane section approximately 500 feet past the center. The original purpose of this project is to widen SR 142 to four lanes to Alcovy Road and to widen a portion of Alcovy Road to tie into a previous widening project. Extending the four-lane section of Alcovy Road north of SR 142 is not required to meet this purpose. Reducing the roadway typical section width would minimize the project's impact on the Bridgestone Sporting Goods property. This concept would reduce the amount of R/W needed for the project, reduce Alcovy Road impacts north of SR 142, and reduce project cost.

The total potential savings if accepted is \$795,000

Idea B-4: Reduce the length of the proposed SR 142 extension north of Alcovy Road.

The current design proposes to extend the four-lane widening of SR 142 to the intersection of American Way / Sims Chapel Road. This design also proposed to lower the roadway profile near the airport to comply with the perception that the existing road conflicts with the glide path of the recently extended runway.

This recommendation would reduce the length of the project along SR 142 by ending the four-lane widening 1,000 feet north of Alcovy Road and tying back into the existing two lane section prior to the intersection of American Way / Sims Chapel Road. The original purpose of this project is to widen SR 142 to four lanes to Alcovy Road and to widen a portion of Alcovy Road to tie into a previous widening project. Improvements to the intersection of Sims Chapel Road /

American Way and SR 142 are not required to meet the need and purpose. The perception that the existing road conflicts with the glide path of the recently constructed runway does not relate to the need and purpose of this project. Reducing the project's length north of Alcovy Road would reduce R/W impacts and wetland impacts south of the Sims Chapel Road. This concept reduces the amount of R/W needed for the project, the project's impact on the airport and wetlands, the pavement width and associated drainage / embankment items, and project cost.

The total potential savings if accepted is \$1,416,000

Idea B-4.1: ALTERNATIVE TO B-4 Reduce the SR 142 typical section width between Nisshinbo Avenue and Sims Chapel Road.

The current design proposes to extend the four-lane widening of SR 142 to the intersection of American Way / Sims Chapel Road. This design also proposed to lower the roadway profile near the airport to comply with the perception that the existing road conflicts with the glide path of the recently extended runway.

This recommendation would reduce the SR 142 typical section width by ending the four-lane widening 1,000 feet north of Alcovy Road and tapering back to the existing three-lane section at Station 264+00. The original purpose of the project is to widen SR 142 to four lanes to Alcovy Road and to widen a portion of Alcovy Road to tie into a previous widening project. Extending the four-lane section to the American Way / Sims Chapel Road intersection is unnecessary to achieve the purpose. Reducing the project's length north of Alcovy Road would reduce R/W impacts and wetland impacts south of the Sims Chapel Road. This concept reduces the amount of R/W needed for the project, the pavement width and associated drainage / embankment items, and project cost.

The total potential savings if accepted is \$338,000

Idea C-4: Optimize the K-Values for vertical curves at the railroad bridge and modify the roadway profile.

The profile grade has been designed for 55 MPH along SR 142 and utilizes ample K-values to allow for clearance over the existing railroad corridor.

This recommendation would optimize the K-values within the 55 MPH design speed design criteria and adjust the profile to balance earthwork. By bringing the roadway profile closer to the existing grade earthwork grading can be optimized and result in an earthwork and R/W cost savings.

The total potential savings if accepted is \$129,000

Idea D-3: Reduce the shoulder width on the bridge from 10 feet to 8 feet.

The original design provides for a bridge width of 91.25 feet. This allows for four 12-foot lanes, two 10-foot outside shoulders, a 16-foot raised median with 2-foot gutters, two side barriers.

This recommendation would narrow the outside shoulders on the bridge from 10 feet to 8 feet. This concept also reduces the width of the MSE wall abutments by the same amount. The change is compliant with the Georgia Department of Transportation “Bridge and Structure Design Policy Manual”, October 2005 Edition with June 2010 revisions.

The total potential savings if accepted is \$50,000

Idea G-3: Construct a rural roadway section with 10-foot outside shoulders on Alcovy Road south of SR 142 and eliminate the closed drainage system and sidewalks.

The current design for Alcovy Road between Harland Drive and SR 142 is a four-lane urban roadway with a variable width (0 – 20 feet) raised median. The roadway typical section includes a variable width raised median, dual 24-foot roadways, dual 4-foot bike lanes, and dual 12-foot shoulders (curb and gutter, 5-foot sidewalk, and clear area).

This recommendation would change the urban roadway typical section to a rural roadway design with outside paved shoulders. This is the same rural section to which SR 142 and Alcovy Road north of SR 142 are being constructed. Constructing a rural roadway section with outside shoulders provides space for the bike lanes on the shoulders in-lieu-of constructing them as part of the full-depth pavement section. It also eliminates the need for a closed drainage system and sidewalks. This concept maintains the same typical section throughout the project, simplifies construction, and reduces project costs.

The total potential savings if accepted is \$442,000

Design Considerations

The VE team also developed two Design Considerations for the final design of the project. They include:

- Consider reducing the size of the temporary R/W easements throughout the project.
- Consider constructing the project with asphalt concrete pavement in lieu of concrete pavement.

SR 142 Widening & Bridge Reconstruction
SUMMARY OF POTENTIAL COST SAVINGS

ITEM No.	CREATIVE IDEA DESCRIPTION	ORIGINAL INITIAL COST	PROPOSED INITIAL COST	INITIAL COST SAVINGS	FUTURE SAVINGS	TOTAL LIFE CYCLE SAVINGS	SAVINGS POTENTIAL* (%)
RECOMMENDATIONS							
A-3	Reduce and / or Eliminate the Sediment Basins due to high cost of R/W.	\$355,000	\$38,000	\$317,000	N/A	\$317,000	100%
B-2	Reduce the Alcovy Road typical section width north of SR 142.	\$795,000	\$0	\$795,000	N/A	\$795,000	100%
B-4	Reduce the length of the proposed SR 142 extension north of Alcovy Road.	\$1,416,000	\$0	\$1,416,000	N/A	\$1,416,000	100%
B-4.1	<u>Alternative to B-4</u> Reduce the SR 142 typical section width between Nisshinbo Avenue and Sims Chapel Road.	\$338,000	\$0	\$338,000	N/A	\$338,000	100%
C-4	Optimize the K-Values for vertical curves at the railroad bridge and modify the roadway profile.	\$73,000	(\$56,000)	\$129,000	N/A	\$129,000	100%
D-3	Reduce the shoulder width on the bridge from 10 feet to 8 feet.	\$1,330,000	\$1,280,000	\$50,000	N/A	\$50,000	100%
G-3	Construct a rural roadway section with 10-foot outside shoulders on Alcovy Road south of SR 142 and eliminate the closed drainage system and sidewalks.	\$442,000	\$96,000	\$346,000	N/A	\$346,000	100%

SR 142 Widening & Bridge Reconstruction
SUMMARY OF POTENTIAL COST SAVINGS

ITEM No.	CREATIVE IDEA DESCRIPTION	ORIGINAL INITIAL COST	PROPOSED INITIAL COST	INITIAL COST SAVINGS	FUTURE SAVINGS	TOTAL LIFE CYCLE SAVINGS	SAVINGS POTENTIAL* (%)
	DESIGN CONSIDERATIONS						
A-4	Consider reducing the size of the temporary R/W easements throughout the project.				N/A	N/A	N/A
B-1	Consider constructing the project with asphalt concrete pavement in lieu of concrete.				N/A	N/A	N/A
	* Note: Savings Potential represents how much of an individual item, exclusive of any overlapping dependent items, can be implemented.						

STUDY IDENTIFICATION

Study Identification

Project: SR 142 Widening & Bridge Reconstruction	Date: August 23-26, 2010
Location: Newton County	

VE Team Members

Name:	Title:	Organization:	Telephone:
Lenor Bromberg	Highway Design	Kennedy Engineering & Associates	678-904-8591
Steven Gaines	Construction	Wolverton & Associates	770-446-8999
Greg Grant	Structures	Wolverton & Associates	770-446-8999
Keith Borkenhagen	VE Team Facilitator	MACTEC	623-556-1875

Project Description

This project will widen and reconstruct SR 142 from the CSX Railroad crossing to just north of the American Way / Sims Chapel Road intersection. It will also widen Alcovy Road from Harland Drive to just north of the Avenue of Champions. State Route 142 will be widened to a four-lane divided roadway with a 20-foot raised median and 10-foot (6 ½-foot paved) outside shoulders. Alcovy Road is being widened to a four-lane urban roadway section with a 20-foot raised median south of SR 142 and to a four-lane divided roadway with a 20-foot raised median and 10-foot (6 ½-foot paved) outside shoulders north of SR 142. Both roadway typical sections will provide for bike lanes. The existing SR 142 Bridge over the CSX Railroad is being replaced with a new longer and wider structure. This project will also lower a short section of SR 142 in front of the Covington Municipal Airport.

Major contract work items include asphalt pavement, roadway grading, bridge replacement, roadway drainage, erosion control, and curb and gutter construction. The total estimated project cost including R/W is \$15.4 million.

Conditions / Constraints

The VE team was informed of several conditions / constraints to consider when developing their recommendations. The conditions / constraints were:

- Both SR 142 and Alcovy Road are designated bike routes.
- The project impacts several wetlands and changes should not increase these impacts.

- The project impacts the Bridgestone Sporting Goods property and changes cannot increase these impacts.

Project Briefing

An overview of the current project status was presented by Jill Franks from Roadway design. The following items were discussed:

- This project will extend SR 142 from the CSX Railroad crossing north to the American Way / Sims Chapel Road intersection. The project also up-grades Alcovy Road from Harland Drive to the Avenue of Champions.
- The project scope for this project has been extended over the project's history. It started with widening SR 142 to Alcovy Road and widening Alcovy Road from SR 142 to the recently completed section at Harland Drive. Scope creep has resulted in reconstructing SR 142 north to American Way / Sims Chapel Road and Alcovy Road north to the Avenue of Champions.
- The section of SR 142 between I-20 and the CSX Railroad crossing was recently reconstructed. The section of SR 142 between Hazelbrand Road and the CSX Railroad crossing will be milled and overlaid and a 20-foot raised concrete median will also be installed.
- The SR 142 typical section will consist of a divided four-lane roadway with a 20-foot raised concrete median and 10-foot (6 ½ foot paved) outside shoulders. The outside shoulders will also serve as bike lanes.
- The Alcovy Road typical section south of SR 142 will consist of an urban four-lane divided roadway with a 20-foot raised concrete median and dual bike lanes. The typical section north of SR 142 will consist of a divided four-lane roadway with a 20-foot raised concrete median and 10-foot (6 ½ foot paved) outside shoulders.
- The bridge over the CSX Railroad will be reconstructed. It will be widened and lengthened to span the existing track plus one future track. Construction of the new bridge will be complicated due to the existence of electric transmission lines crossing SR 142 near the north abutment. This bridge has been redesigned using MSE wall abutments to minimize constructability issues with the transmission lines.
- SR 142 is being lowered near the Covington Municipal Airport due to perceived flight conflicts that were caused when the runway was extended.
- The original project documents proposed to construct the roadways using asphalt pavement. At this design briefing, a pavement design report was presented stating a life cycle cost (LCC) analysis showed PCC pavement being the preferred alternative.
- R/W appraisals are underway on this project.
- This project will not impact the cemetery by Sims Chapel Road.
- The proposed widening of Alcovy Road north of SR 142 will impact the Bridgestone Sporting Goods property. Minimizing impacts to this property is critical.

**Figure 1
Project Project Map**

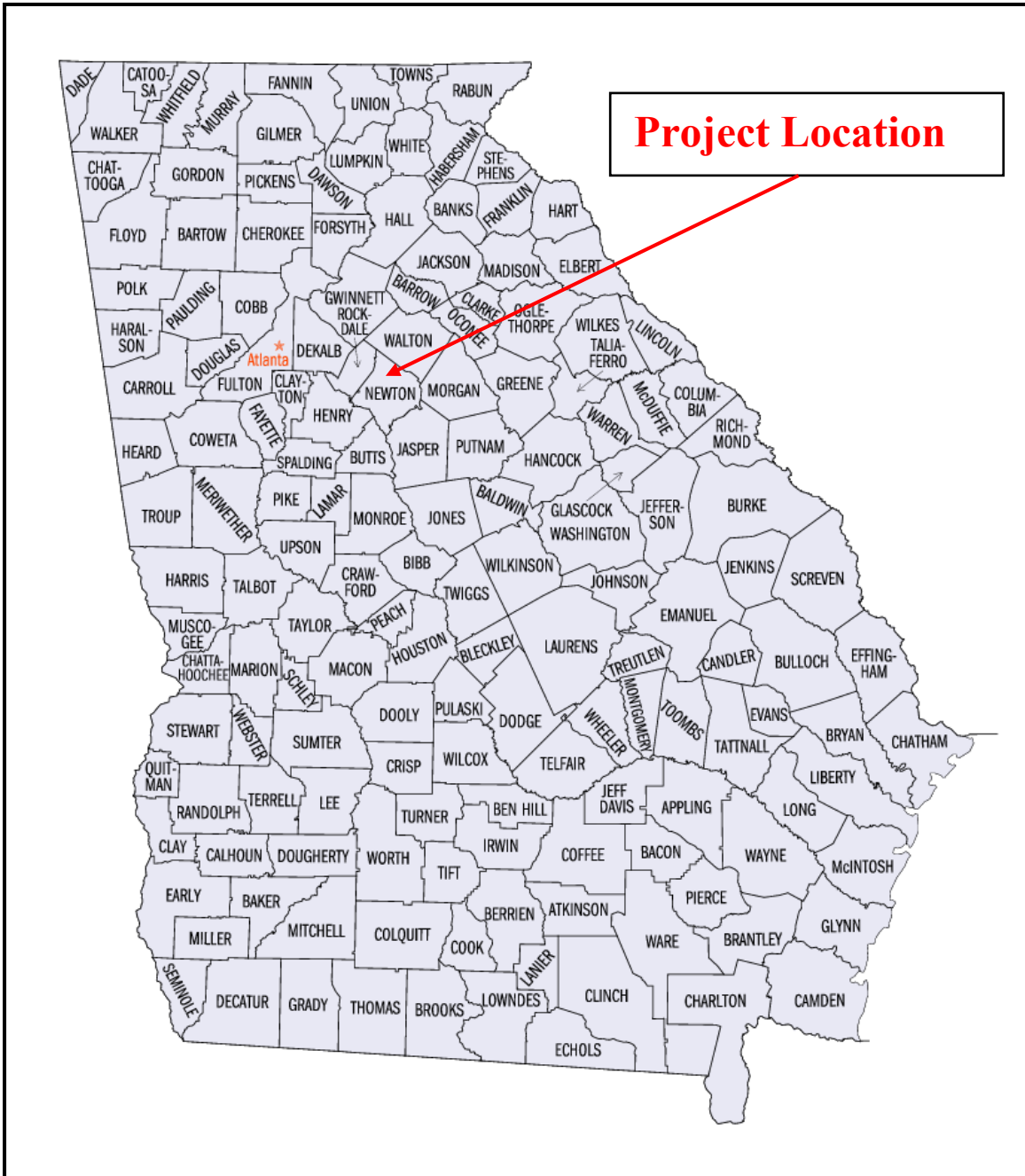

County Map of Georgia

Figure 2
Project Sketch Map

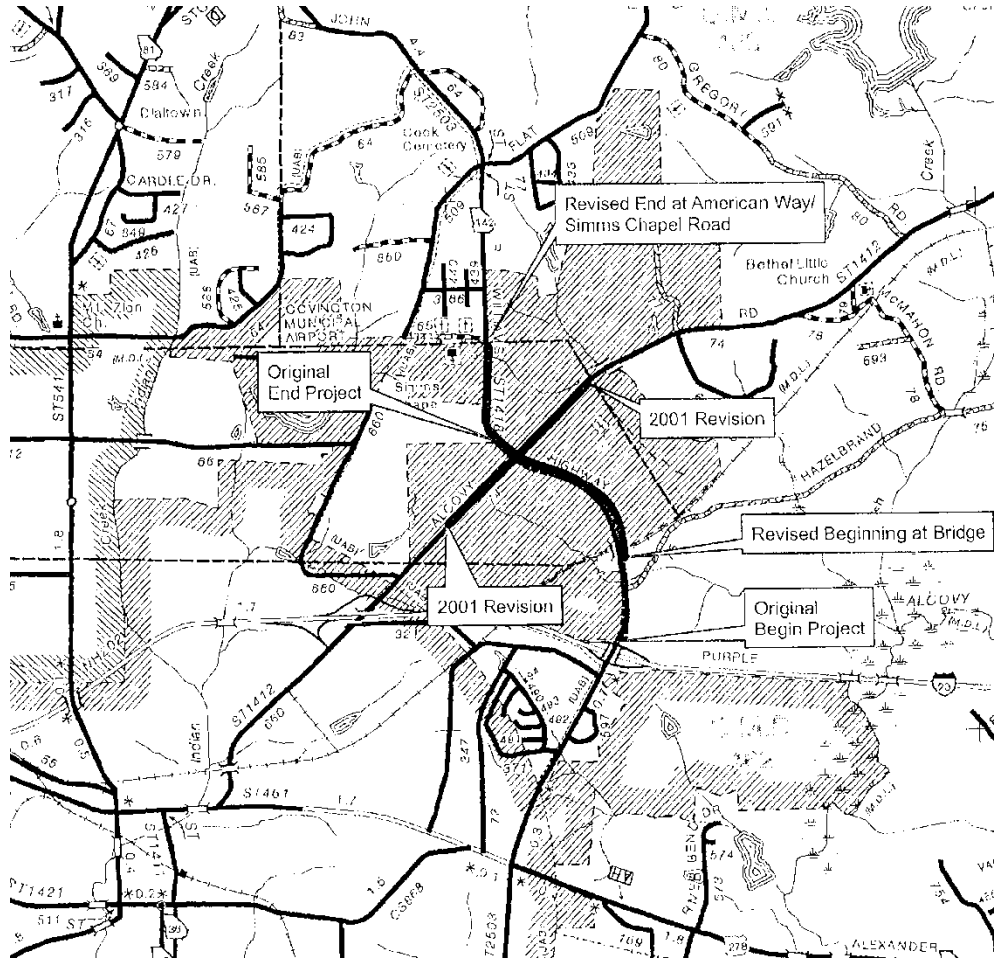

VE RECOMMENDATIONS

DEVELOPMENT AND RECOMMENDATION PHASE

SR 142 Widening and Bridge Replacement

IDEA No.: A-3	Sheet No.: 1 of 4	CREATIVE IDEA: Reduce and / or Eliminate the Sediment Basins due to high cost of R/W.
-------------------------	-----------------------------	---

Comp By: SG Date: 8/26/2010 Checked By: KB Date: 8/26/2010

Original Concept:

The original concept proposes to install sediment basins along the project to provide for sediment storage requirements.

Proposed Change:

The revised concept proposes to remove the sediment basins and install additional ditch checks to provide for required sediment storage.

Justification:

Although the installation of sediment basins is optimal for providing required sediment storage, they are not practical to install in areas with high R/W costs. The environmental benefit of installing the basins does not justify the required R/W costs. Additional ditch checks may be installed to offset the loss of sediment storage provided by the basins.

COST SUMMARY	INITIAL COST	FUTURE COST	TOTAL L. C. COST SAVINGS
Original	\$355,000		
Proposed	\$38,000		
Savings	\$317,000		\$317,000
FUTURE COST: – Savings		N/A	N/A
TOTAL PRESENT WORTH SAVINGS			\$317,000

SKETCH

Project: SR 142 Widening and Bridge Replacement

Idea No.: A-3
Client: GDOT
Sheet 2 of 4

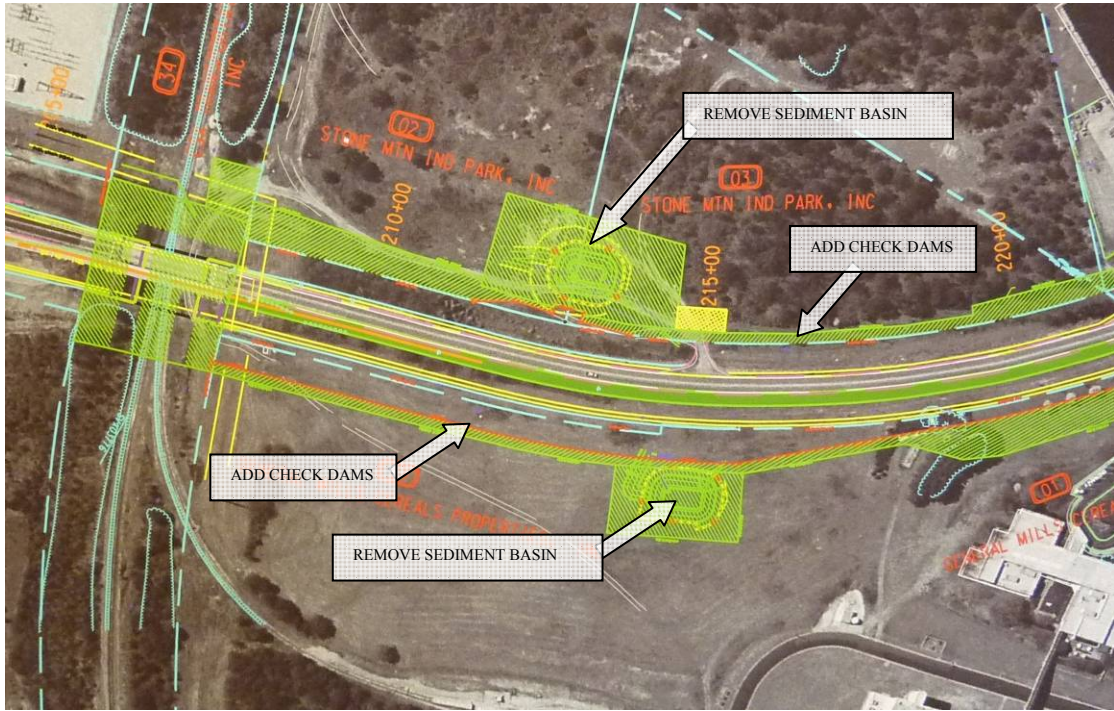

COST WORKSHEET

Project: SR 142 Widening and Bridge Replacement					Idea No.: A-3 Client: GDOT Sheet 3 of 4		
CONSTRUCTION ELEMENT		ORIGINAL ESTIMATE			NEW ESTIMATE		
Item	Unit	No. Units	Cost/Unit	Total Cost	No. Units	Cost/Unit	Total Cost
Original Design:							
R/W	LS	1	\$317,900	\$317,900			
Construct Sediment Basin	EA	5	\$6,287	\$31,435			
Maintain Sediment Basin	EA	5	\$1,060	\$5,300			
VE Design							
Construct Rip Rap Check Dam	EA				200	\$188.00	\$37,060
SUBTOTAL				\$354,635			\$37,600
TOTAL ROUNDED				\$355,000			\$38,000

CALCULATIONS

Project: SR 142 Widening and Bridge Replacement

Idea No.: A-3

Client: GDOT

Sheet 4 of 4

Original Concept:

Permanent Easement Areas for Sediment Basins

Factors – 50% (Counteroffers/Condemnation), 10% (Market Appreciation)

Parcel 1 = 21,717 SF

Cost (Parcel 1) = (21,717 SF)(\$5.00/SF)(0.5) = \$54,293

Parcel 2 = 17,847 SF

Cost (Parcel 2) = (17,847 SF)(\$2.00/SF)(0.5) = \$17,847

Parcel 3 = 20,874 SF

Cost (Parcel 3) = (20,874 SF)(\$2.25/SF)(0.5) = \$23,483

Parcel 6 (Basin 1) = 17,341 SF / Parcel 6 (Basin 2) = 6,985 SF

Parcel 6 (Total) = 24,326 SF

Cost (Parcel 6) = (24,326 SF)(\$5.00/SF)(0.5) = \$48,652

Parcel 18 = 24,196 SF

Cost (Parcel 18) = (24,196 SF)(\$4.00/SF)(0.5) = \$48,392

Total Cost = (1.1)(1.5)(\$54,293 + \$17,847 + \$23,483 + \$48,652 + \$48,392) = \$317,900

Construction of Sediment Basins

Cost = (5)(\$6,287) = \$31,435

Maintenance of Sediment Basins

Cost = (5)(\$1,060) = \$5,300

Revised VE Concept:

Right-of-Way Area = 0 SY

Cost of Additional Rip Rap Check Dams (SR 142) = (200)(\$188) = \$37,600

DEVELOPMENT AND RECOMMENDATION PHASE

SR 142 Widening & Bridge Reconstruction

IDEA No.: B-2	Sheet No.: 1 of 6	CREATIVE IDEA: Reduce the Alcovy Road typical section width north of SR 142.
-------------------------	-----------------------------	--

Comp By: SG Date: 8/26/2010 Checked By: KB Date: 8/26/2010

Original Concept: The original design proposes to extend the four-lane widening of Alcovy Road to the Avenue of Champions.

Proposed Change: The revised concept proposes to reduce the length of the project along Alcovy Road by ending the four-lane widening at the entrance to the Newton County Enforcement Center and tying into the existing two lane section approximately 500 feet past the center (Sta. 1253+00). The left lane of the two northbound through lanes would be dropped as the left turn lane into the center. The right lane of the two southbound through lanes would be created just south of the entrance into the center.

Justification: The need and purpose of the project is to widen SR 142 to four lanes to Alcovy Road and to widen a portion of Alcovy Road to tie into a previous widening project. The extension of the four-lane section on Alcovy Road to the Avenue of Champions is not required to meet this need and purpose. The Alcovy Road DHV northbound traffic for year 2031 decrease 33 percent as it passes SR 142.

Reducing the roadway typical section width would minimize the project’s impact on the Bridgestone property and eliminate the Alcovy Road widening north of the Avenue of Champions. Existing Alcovy Road north of the Avenue of Champions consists of a single traffic lane in each direction with widened sections to provide for right or left turn lanes into various businesses. This concept would reduce the amount of R/W needed for the project, reduce Alcovy Road impacts north of SR 142, and reduce project cost.

COST SUMMARY	INITIAL COST	FUTURE COST	TOTAL L. C. COST SAVINGS
Original	\$795,000		
Proposed	\$0		
Savings	\$795,000		\$795,000
FUTURE COST: – Savings		N/A	N/A
TOTAL PRESENT WORTH SAVINGS			\$795,000

SKETCH

Project: SR 142 Widening and Bridge Replacement

Idea No.: B-2
Client: GDOT
Sheet 2 of 6



COST WORKSHEET

Project: SR 142 Widening & Bridge Reconstruction					Idea No.: B-2 Client: GDOT Sheet 3 of 6		
					CONSTRUCTION ELEMENT		ORIGINAL ESTIMATE
Item	Unit	No. Units	Cost/Unit	Total Cost	No. Units	Cost/Unit	Total Cost
Original design:							
R/W	LS	1	\$235,785	\$235,786	0		\$0
Earthwork	CY	4,292	\$5.00	\$21,460	0		\$0
Full Depth Pavement	SY	9,148	\$45.00	\$411,660	0		\$0
Shoulder Pavement	SY	1,675	\$18.00	\$30,150	0		\$0
Traffic Control	LS	1	\$50,000	\$50,000	0		\$0
Temp Erosion Control	LS	1	\$15.888	\$15.888	0		\$0
Perm Erosion Control	LS	1	\$7,042	\$7,042	0		\$0
SUBTOTAL				\$794,917			\$0
TOTAL ROUNDED				\$795,000			\$0

CALCULATIONS

Project: SR 142 Widening & Bridge Reconstruction

Idea No.: B-2
Client: GDOT
Sheet 4 of 6

Cost of Asphalt Pavement: SR 142: 10 ½ inches on 12 inches of GAB

$$(1.5 \text{ in} / 12 \text{ ft}) \times (150 \text{ \#} / \text{CF}) \times (1 \text{ Ton} / 2,000 \text{ \#}) = 0.009375 \text{ Ton} / \text{SF}$$

$$(2.0 \text{ in} / 12 \text{ ft}) \times (150 \text{ \#} / \text{CF}) \times (1 \text{ Ton} / 2,000 \text{ \#}) = 0.0125 \text{ Ton} / \text{SF}$$

$$(7.0 \text{ in} / 12 \text{ ft}) \times (150 \text{ \#} / \text{CF}) \times (1 \text{ Ton} / 2,000 \text{ \#}) = 0.04375 \text{ Ton} / \text{SF}$$

$$(12 \text{ in} / 12 \text{ ft}) \times (135 \text{ \#} / \text{CF}) \times (1 \text{ Ton} / 2,000 \text{ \#}) = 0.0675 \text{ Ton} / \text{SF}$$

Cost per SY

$$(0.009375 \text{ Ton} / \text{SY} \times 9 \text{ SF} / \text{SY} \times \$61.84 / \text{Ton}) = \$5.22$$

$$(0.0125 \text{ Ton} / \text{SY} \times 9 \text{ SF} / \text{SY} \times \$59.17 / \text{Ton}) = \$6.66$$

$$(0.04375 \text{ Ton} / \text{SY} \times 9 \text{ SF} / \text{SY} \times \$55.37 / \text{Ton}) = \$21.80$$

$$(0.0675 \text{ Ton} / \text{SY} \times 9 \text{ SF} / \text{SY} \times \$18.00 / \text{Ton}) = \$10.94$$

$$\text{Cost} = \$5.22 + \$6.66 + \$21.80 + \$10.94 = \$44.62 / \text{SY} \quad \text{Use } \mathbf{\$45.00}$$

Cost of Asphalt Shoulder: 3 ½ inches on 6 inches of GAB

$$(0.009375 \text{ Ton} / \text{SY} \times 9 \text{ SF} / \text{SY} \times \$61.84 / \text{Ton}) = \$5.22$$

$$(0.0125 \text{ Ton} / \text{SY} \times 9 \text{ SF} / \text{SY} \times \$59.17 / \text{Ton}) = \$6.66$$

$$(0.0675 \text{ Ton} / \text{SY} \times 9 \text{ SF} / \text{SY} \times \$18.00 / \text{Ton}) \times \frac{1}{2} = \$5.97$$

$$\text{Cost} = \$5.22 + \$6.66 + \$5.97 = \$17.85 / \text{SY} \quad \text{Use } \mathbf{\$18.00}$$

Original Concept (Alcovy Rd/Ave of Champions N of Sta. 1253+00)

R/W (Cost Determined from R/W Parcel Spreadsheet)

Factors – 50% (Counteroffers/Condemnation), 10% (Market Appreciation)

$$\text{Total R/W Cost from Table} = (\$142,890)(1.1)(1.5) = \$235,786$$

Earthwork

Assumption: average SF earthwork reduction per cross section on SR 142

$$\text{Volume} = (1159 \text{ lf})(100 \text{ SF}) / 27 = 4,292 \text{ cy}$$

Full Depth Pavement

$$\text{Area} = (83 \text{ ft})(48 \text{ ft}) + (220 \text{ ft})(72 \text{ ft}) + (0.5)(100 \text{ ft})(72 \text{ ft} + 55 \text{ ft}) + (0.5)(420 \text{ ft})(55 \text{ ft} + 47 \text{ ft}) + (0.5)(325 \text{ ft})(47 \text{ ft} + 56 \text{ ft}) + (500 \text{ ft})(36 \text{ ft}) = 82,332 \text{ SF} = 9,148 \text{ SY}$$

CALCULATIONS

Project: SR 142 Widening & Bridge Reconstruction

Idea No.: B-2
Client: GDOT
Sheet 5 of 6

Shoulder Pavement

$$\text{Area} = (2)(1159 \text{ ft})(6.5 \text{ ft}) = 15,067 \text{ SF} = 1,675 \text{ SY}$$

Traffic Control (Assume 5% Savings)

$$\text{Cost} = (0.05)(\$1,000,000) = \$50,000$$

Temporary Erosion Control (Assume 5% Savings)

$$\text{Cost} = (0.05)(\$317,768) = \$15,888$$

Permanent Erosion Control (Assume 5% Savings)

$$\text{Cost} = (0.05)(\$140,846) = \$7,042$$

Revised Concept

R/W (Cost Determined from R/W Parcel Spreadsheet)

$$\text{Cost} = \$0$$

Earthwork

$$\text{Volume} = 0 \text{ CY}$$

Full Depth Pavement

$$\text{Area} = 0 \text{ SY}$$

Shoulder Pavement

$$\text{Area} = 0 \text{ SY}$$

Traffic Control (Assume 10% Savings)

$$\text{Cost} = \$0$$

Temporary Erosion Control (Assume 10% Savings)

$$\text{Cost} = \$0$$

Permanent Erosion Control

$$\text{Cost} = \$0$$

CALCULATIONS

Project: SR 142 Widening & Bridge Reconstruction

Idea No.: B-2
Client: GDOT
Sheet 6 of 6

ITEM	UNIT S	No. UNITS	COST/ UNIT	TOTAL COST
Right-of-way Savings:				
Parcel 14A	SF	1,000	4.50	4,500
Parcel 14C	SF	0	4.00	
Parcel 29	SF	7,598	5.00	37,990
Parcel 30	SF	3,585	1.25	4,481
Parcel 31	SF	7,132	3.50	24,962
Parcel 32	SF	405	3.00	1,215
Parcel 33	SF	1,523	2.00	3,046
Easement Savings (50% of right-of-way cost per unit):				
Parcel 14A	SF	0	2.25	
Parcel 14C	SF	2,973	2.00	5,946
Parcel 29	SF	6,137	2.50	15,343
Parcel 30	SF	2,463	0.63	1,539
Parcel 31	SF	13,026	1.75	22,796
Parcel 32	SF	5,284	1.50	7,926
Parcel 33	SF	13,146	1.00	13,146

DEVELOPMENT AND RECOMMENDATION PHASE

SR 142 Widening and Bridge Replacement

IDEA No.: B-4	Sheet No.: 1 of 5	CREATIVE IDEA: Reduce the length of the proposed SR 142 extension north of Alcovy Road.
-------------------------	-----------------------------	---

Comp By: SG Date: 8/262010 Checked By: KB Date: 8/262010

Original Concept: The original design proposes to extend the four-lane widening of SR 142 beyond Alcovy Road and proposes improvements to the intersection of American Way / Sims Chapel Road and SR 142. The proposed profile near the airport is also being lowered to comply with the perception that the existing road conflicts with the glide path of the recently extended runway.

Proposed Change: The revised concept proposes to reduce the length of the project along SR 142 by ending the four-lane widening 1,000 feet north of Alcovy Road and tying back into the existing two lane section prior to the intersection of American Way / Sims Chapel Road and SR 142. This concept would tie back into the existing road at Sta. 264+00 and does not propose lowering the roadway profile near the airport.

Justification: The need and purpose of this project is to widen SR 142 to four lanes to Alcovy Road and to widen a portion of Alcovy Road to tie into a previous widening project. Improvements to the intersection of Sims Chapel Road / American Way and SR 142 are not required to meet the need and purpose. The perception that the existing road conflicts with the glide path of the recently constructed runway does not relate to the need and purpose of this project.

Reducing the project's length north of Alcovy Road would reduce R/W impacts and wetland impacts south of the Sims Chapel Road / American Way intersection. This concept would maintain the existing intersection at Sims Chapel Road / American Way. This concept reduces the amount of R/W needed for the project, the project's impact on the airport and wetlands, the pavement width and associated drainage / embankment items, and project cost.

COST SUMMARY	INITIAL COST	FUTURE COST	TOTAL L. C. COST SAVINGS
Original	\$1,416,000		
Proposed	\$0		
Savings	\$1,416,000		\$1,416,000
FUTURE COST: – Savings		N/A	N/A
TOTAL PRESENT WORTH SAVINGS			\$1,416,000

SKETCH

Project: SR 142 Widening and Bridge Replacement

Idea No.: B-4
Client: GDOT
Sheet 2 of 5

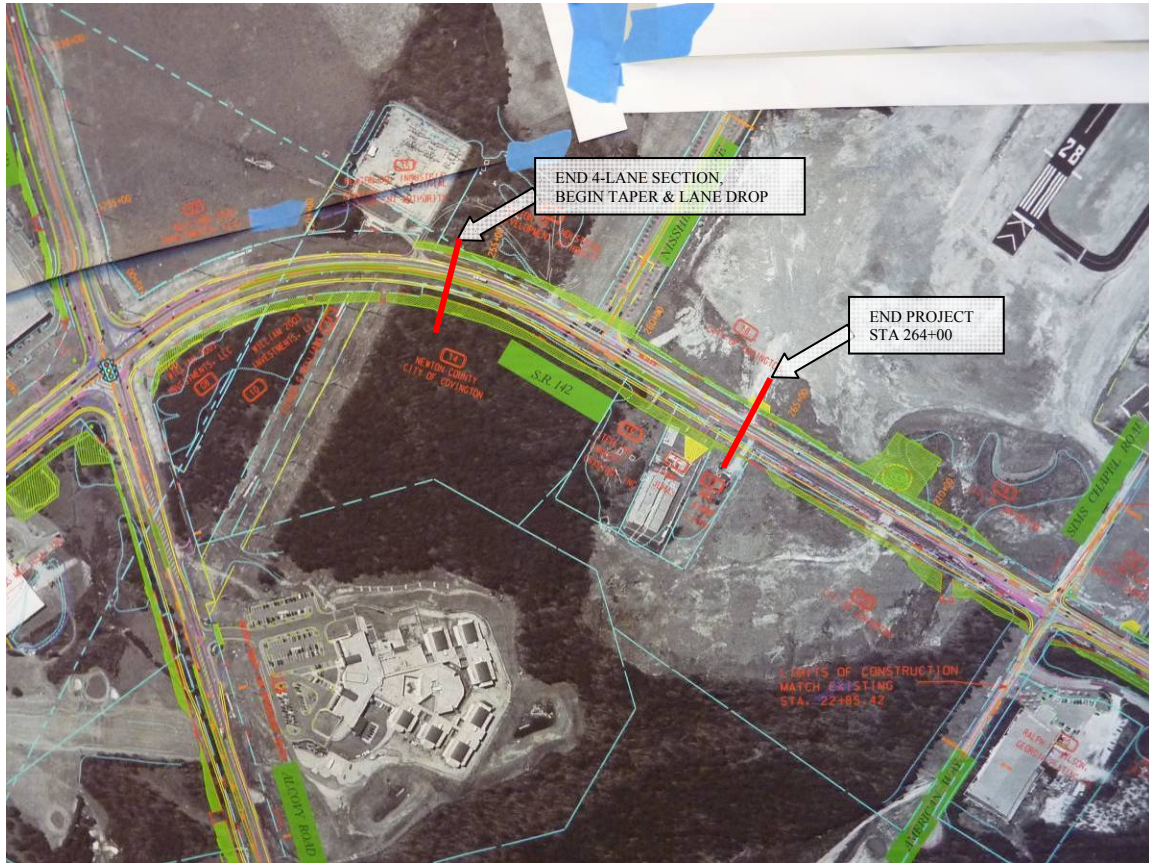

CALCULATIONS

Project: SR 142 Widening and Bridge Replacement

Idea No.: B-4
Client: GDOT
Sheet 4 of 5

Cost of Asphalt Pavement: SR 142: 10 ½ inches on 12 inches of GAB

$$(1.5 \text{ in} / 12 \text{ ft}) \times (150 \# / \text{CF}) \times (1 \text{ Ton} / 2,000 \#) = 0.009375 \text{ Ton} / \text{SF}$$

$$(2.0 \text{ in} / 12 \text{ ft}) \times (150 \# / \text{CF}) \times (1 \text{ Ton} / 2,000 \#) = 0.0125 \text{ Ton} / \text{SF}$$

$$(7.0 \text{ in} / 12 \text{ ft}) \times (150 \# / \text{CF}) \times (1 \text{ Ton} / 2,000 \#) = 0.04375 \text{ Ton} / \text{SF}$$

$$(12 \text{ in} / 12 \text{ ft}) \times (135 \# / \text{CF}) \times (1 \text{ Ton} / 2,000 \#) = 0.0675 \text{ Ton} / \text{SF}$$

Cost per SY

$$(0.009375 \text{ Ton} / \text{SY} \times 9 \text{ SF} / \text{SY} \times \$61.84 / \text{Ton}) = \$5.22$$

$$(0.0125 \text{ Ton} / \text{SY} \times 9 \text{ SF} / \text{SY} \times \$59.17 / \text{Ton}) = \$6.66$$

$$(0.04375 \text{ Ton} / \text{SY} \times 9 \text{ SF} / \text{SY} \times \$55.37 / \text{Ton}) = \$21.80$$

$$(0.0675 \text{ Ton} / \text{SY} \times 9 \text{ SF} / \text{SY} \times \$18.00 / \text{Ton}) = \$10.94$$

$$\text{Cost} = \$5.22 + \$6.66 + \$21.80 + \$10.94 = \$44.62 / \text{SY} \quad \text{Use } \mathbf{\$45.00}$$

Cost of Asphalt Shoulder: 3 ½ inches on 6 inches of GAB

$$(0.009375 \text{ Ton} / \text{SY} \times 9 \text{ SF} / \text{SY} \times \$61.84 / \text{Ton}) = \$5.22$$

$$(0.0125 \text{ Ton} / \text{SY} \times 9 \text{ SF} / \text{SY} \times \$59.17 / \text{Ton}) = \$6.66$$

$$(0.0675 \text{ Ton} / \text{SY} \times 9 \text{ SF} / \text{SY} \times \$18.00 / \text{Ton}) \times \frac{1}{2} = \$5.97$$

$$\text{Cost} = \$5.22 + \$6.66 + \$5.97 = \$17.85 / \text{SY} \quad \text{Use } \mathbf{\$18.00}$$

Original Concept

R/W (Cost Determined from R/W Parcel Spreadsheet)

Assume 100% right-of-way cost savings for parcels 14B, 14C, 19, 21 & 22

Assume 75% Saving for Parcel 18

Factors – 50% (Counteroffers/Condemnation), 10% (Market Appreciation)

$$100\% \text{ Cost Savings} = \$225,284 + \$59,552 + \$1,718 + \$1,436 + \$1,364 = \$289,354$$

$$75\% \text{ Cost Savings} = (0.75)(\$ 88,366) = \$66,275$$

$$\text{Total Savings} = (1.5)(1.1)(\$289,354 + \$66,275) = \$586,788$$

Earthwork

Assumption: average 200 SF earthwork reduction per cross section on SR 142

$$\text{Volume} = (2,000 \text{ lf})(200 \text{ SF})/27 = 14,814 \text{ CY}$$

CALCULATIONS

Project: SR 142 Widening and Bridge Replacement

Idea No.: B-4
Client: GDOT
Sheet 5 of 5

Full Depth Pavement

Area 1 (SR 142 Station 264+00 to 275+00) = (1100 ft)(68 ft) = 74,800 SF = 8,311 SY

Area 2 (SR 142 Station 275+00 to 284+00 – ave width 30 ft) = (900 ft)(30 ft) = 27,000 SF = 3,000 SY

Area 3 (Sims/American – approx 400 lf) = (400 ft)(24 ft) = 9,600 SF = 1,067 SY

Total = 8,311 + 3,000 + 1,067 = 12,378 SF

Shoulder Pavement

Area (SR 142 Station 264+00 to 284+00) = (2000 ft)(2)(6.5 ft) = 26,000 SF = 2,889 SY

Traffic Control (Assume 10% Savings)

Cost = (0.1)(\$1,000,000) = \$100,000

Temporary Erosion Control (Assume 10% Savings)

Cost = (0.1)(\$317,768) = \$31,777

Permanent Erosion Control

Cost = (0.1)(\$140,846) = \$14,085

Revised Concept

R/W (Cost Determined from R/W Parcel Spreadsheet)

Cost = \$0

Earthwork

Volume = 0 cy

Full Depth Pavement

Area = 0 SY

Shoulder Pavement

Area = 0 SY

Traffic Control (Assume 10% Savings)

Cost = \$0

Temporary Erosion Control (Assume 10% Savings)

Cost = \$0

Permanent Erosion Control

Cost = \$0

DEVELOPMENT AND RECOMMENDATION PHASE

SR 142 Widening & Bridge Reconstruction

IDEA No.: B-4.1	Sheet No.: 1 of 5	CREATIVE IDEA: <u>ALTERNATIVE TO B-4</u> Reduce the SR 142 typical section width between Nisshinbo Avenue and Sims Chapel Road.
---------------------------	-----------------------------	---

Comp By: SG Date: 8/26/2010 Checked By: KB Date: 8/26/2010

Original Concept:

The original design proposes to extend the four-lane widening of SR 142 to the intersection of American Way / Sims Chapel Road and SR 142. The proposed profile near the airport is also being lowered to comply with the perception that the existing road conflicts with the glide path of the recently extended runway. The pavement width from Station 262+40 to the intersection of SR 142 and American Way / Sims Chapel Road is 68 feet.

Proposed Change:

The revised concept proposes to reduce the width of the SR 142 typical section by ending the four-lane widening 1,000 feet north of Alcovy Road and tapering back to the existing three-lane section at Station 264+00.

Justification:

The need and purpose of the project is to widen SR 142 to four lanes to Alcovy Road and to widen a portion of Alcovy Road to tie into a previous widening project. The extension of the four-lane section to American Way/Sims Chapel Road is unnecessary to achieve the need and purpose.

Reducing the project's length north of Alcovy Road would reduce R/W impacts and wetland impacts south of the Sims Chapel Road / American Way intersection. This concept would maintain the existing intersection at Sims Chapel Road / American Way. This concept reduces the amount of R/W needed for the project, the pavement width and associated drainage / embankment items, and project cost.

COST SUMMARY	INITIAL COST	FUTURE COST	TOTAL L. C. COST SAVINGS
Original	\$338,000		
Proposed	\$0		
Savings	\$338,000		\$338,000
FUTURE COST: – Savings		N/A	N/A
TOTAL PRESENT WORTH SAVINGS			\$338,000

SKETCH

Project: SR 142 Widening and Bridge Replacement

Idea No.: B-4.1
Client: GDOT
Sheet 2 of 5



CALCULATIONS

Project: SR 142 Widening & Bridge Reconstruction

Idea No.: B-4.1

Client: GDOT

Sheet 4 of 5

Cost of Asphalt Pavement: SR 142: 10 ½ inches on 12 inches of GAB

$$(1.5 \text{ in} / 12 \text{ ft}) \times (150 \# / \text{CF}) \times (1 \text{ Ton} / 2,000 \#) = 0.009375 \text{ Ton} / \text{SF}$$

$$(2.0 \text{ in} / 12 \text{ ft}) \times (150 \# / \text{CF}) \times (1 \text{ Ton} / 2,000 \#) = 0.0125 \text{ Ton} / \text{SF}$$

$$(7.0 \text{ in} / 12 \text{ ft}) \times (150 \# / \text{CF}) \times (1 \text{ Ton} / 2,000 \#) = 0.04375 \text{ Ton} / \text{SF}$$

$$(12 \text{ in} / 12 \text{ ft}) \times (135 \# / \text{CF}) \times (1 \text{ Ton} / 2,000 \#) = 0.0675 \text{ Ton} / \text{SF}$$

Cost per SY

$$(0.009375 \text{ Ton} / \text{SY} \times 9 \text{ SF} / \text{SY} \times \$61.84 / \text{Ton}) = \$5.22$$

$$(0.0125 \text{ Ton} / \text{SY} \times 9 \text{ SF} / \text{SY} \times \$59.17 / \text{Ton}) = \$6.66$$

$$(0.04375 \text{ Ton} / \text{SY} \times 9 \text{ SF} / \text{SY} \times \$55.37 / \text{Ton}) = \$21.80$$

$$(0.0675 \text{ Ton} / \text{SY} \times 9 \text{ SF} / \text{SY} \times \$18.00 / \text{Ton}) = \$10.94$$

$$\text{Cost} = \$5.22 + \$6.66 + \$21.80 + \$10.94 = \$44.62 / \text{SY} \quad \text{Use } \mathbf{\$45.00}$$

Original Concept

R/W (Cost Determined from R/W Parcel Spreadsheet – Assume 32' width savings)

Parcel 14B (Assume 16' R/W width savings Sta. 265+00 to 274+00)

$$\text{Cost} = (900 \text{ ft})(16 \text{ ft})(\$4.50/\text{SF}) = \$64,800$$

Parcel 18 (Assume 16' Esmt width savings Sta. 265+00 to 272+00)

$$\text{Cost} = (700 \text{ ft})(16 \text{ ft})(\$4.00/\text{SF})(0.5) = \$22,400$$

$$\text{Total Savings} = (1.5)(1.1)(\$64,800 + \$22,400) = \$143,880$$

Earthwork

Assumption: average 200 SF earthwork reduction per cross section on SR 142

$$\text{Volume} = (1,000 \text{ lf})(100 \text{ SF})/27 = 3,703 \text{ CY}$$

Full Depth Pavement (Assume Reduction from 68' width to 36' width)

$$\text{Area} = (1100 \text{ ft})(32 \text{ ft}) = 35,200 \text{ SF} = 3,912 \text{ SY}$$

CALCULATIONS

Project: SR 142 Widening & Bridge Reconstruction

Idea No.: B-4.1
Client: GDOT
Sheet 5 of 5

Revised Concept

R/W

Cost = \$0

Earthwork

Volume = 0 CY

Full Depth Pavement

Area = 0 SY

DEVELOPMENT AND RECOMMENDATION PHASE

SR 142 Widening and Bridge Replacement

IDEA No.: C-4	Sheet No.: 1 of 7	CREATIVE IDEA: Optimize the K-values for the vertical curves at the railroad bridge and modify the roadway profile.
-------------------------	-----------------------------	---

Comp By: LB Date: 08/25/2010 Checked By: KB Date: 08/25/2010

Original Concept:

Profile grade has been designed at 55 MPH along SR 142 and utilizes ample K-values to allow for clearance over the existing railroad corridor.

Proposed Change:

Utilize optimal K-values within the 55 MPH design speed design criteria and adjust profile to balance earthwork.

Justification:

By bringing the roadway profile closer to the existing grade earthwork grading can be optimized and result in an earthwork and right-of-way cost savings.

COST SUMMARY	INITIAL COST	FUTURE COST	TOTAL L. C. COST SAVINGS
Original	\$73,000		
Proposed	(\$56,000)		
Savings	\$129,000		\$129,000
FUTURE COST: – Savings		N/A	N/A
TOTAL PRESENT WORTH SAVINGS			\$129,000

SKETCH

Project: SR 142 Widening and Bridge Replacement

Idea No.: C-4
 Client: GDOT
 Sheet 2 of 7

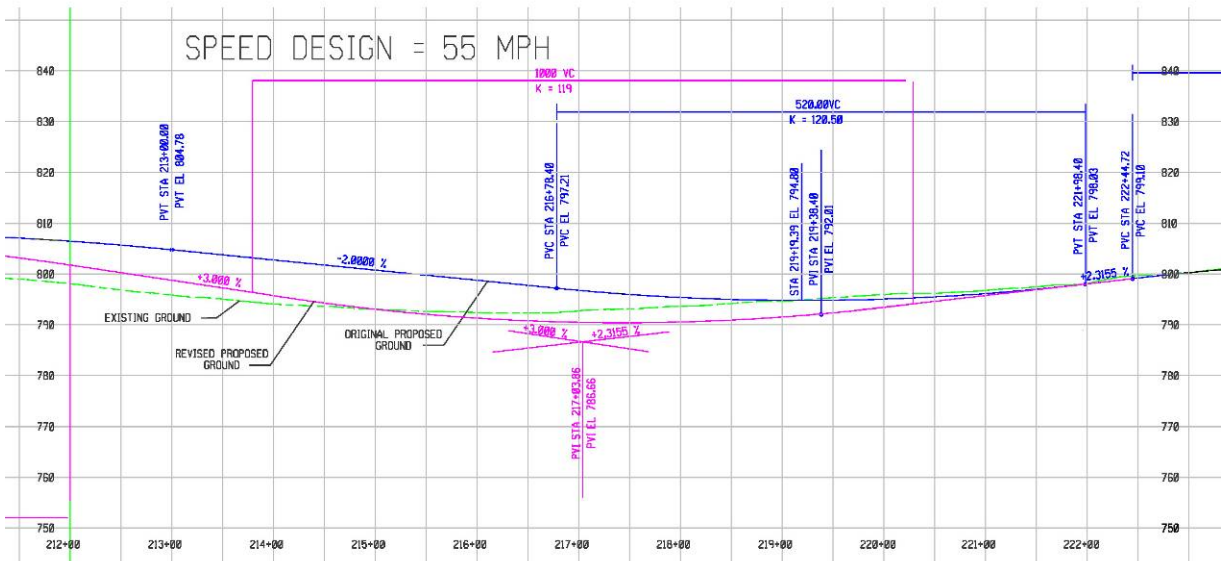
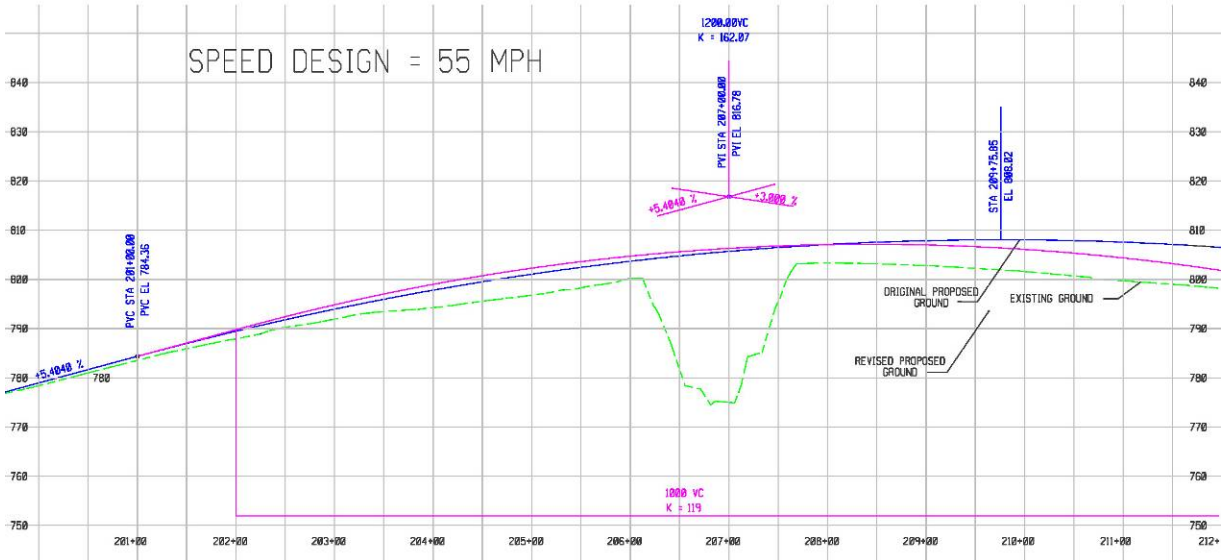

Legend:
— Original Proposed Profile Information
— Revised Proposed Profile Information

CALCULATIONS

Project: SR 142 Widening and Bridge Replacement

Idea No.: C-4
 Client: GDOT
 Sheet 4 of 7

Vertical curve calculations:

Curve #1		Input Data		Misc Data	
P.V.I. Station	207+00.00	Curve Type	Crest		
P.V.I. Elevation	816.78	K	119		
L.V.C.	1000.00	HI PT STA	208+43.0271		
g1	5.4040%	HI PT ELEV	807.135		
g2	-3.0000%				

Description	Station	Elevation	Offset	Width	SE
P.V.C.	202+00.00	789.76		100.00	-2.0%
P.V.I.	207+00.00	806.28			
P.V.T.	212+00.00	801.78			

Description	Station	Elevation	Total Offset	Offset 1	rate 1	Drop/Rise 1	ELEVATION	Min 23' clear req'd
Bent 1	206+57.00	805.68	44.000	44	-2.0%	(0.88)	804.80	23.76
Bent 2	207+55.00	806.81	44.000	44	-2.0%	(0.88)	805.93	
			44.000	44	-2.0%	(0.88)	-0.88	
Point of interest	219+00.00	780.78	44.000	44	-2.0%	(0.88)	779.90	
			44.000	44	-2.0%	(0.88)	-0.88	
			44.000	44	-2.0%	(0.88)	-0.88	
			44.000	44	-2.0%	(0.88)	-0.88	
			44.000	44	-2.0%	(0.88)	-0.88	

Curve #2		Input Data		Misc Data	
P.V.I. Station	217+03.86	Curve Type	SAG		
P.V.I. Elevation	786.66	K	123		
L.V.C.	650.00	LOW PT STA	217+46.7845		
g1	-3.0000%	LOW PT ELEV	790.891		
g2	2.3000%				

Description	Station	Elevation	Offset	Width	SE
P.V.C.	213+78.86	796.41		100.00	-2.0%
P.V.I.	217+03.86	790.97			
P.V.T.	220+28.86	794.14			

OK

CALCULATIONS

Project: SR 142 Widening and Bridge Replacement

Idea No.: C-4
Client: GDOT
Sheet 5 of 7

Change in earthwork every 250-feet along proposed profile from Station 201+00 to 221+98.40:

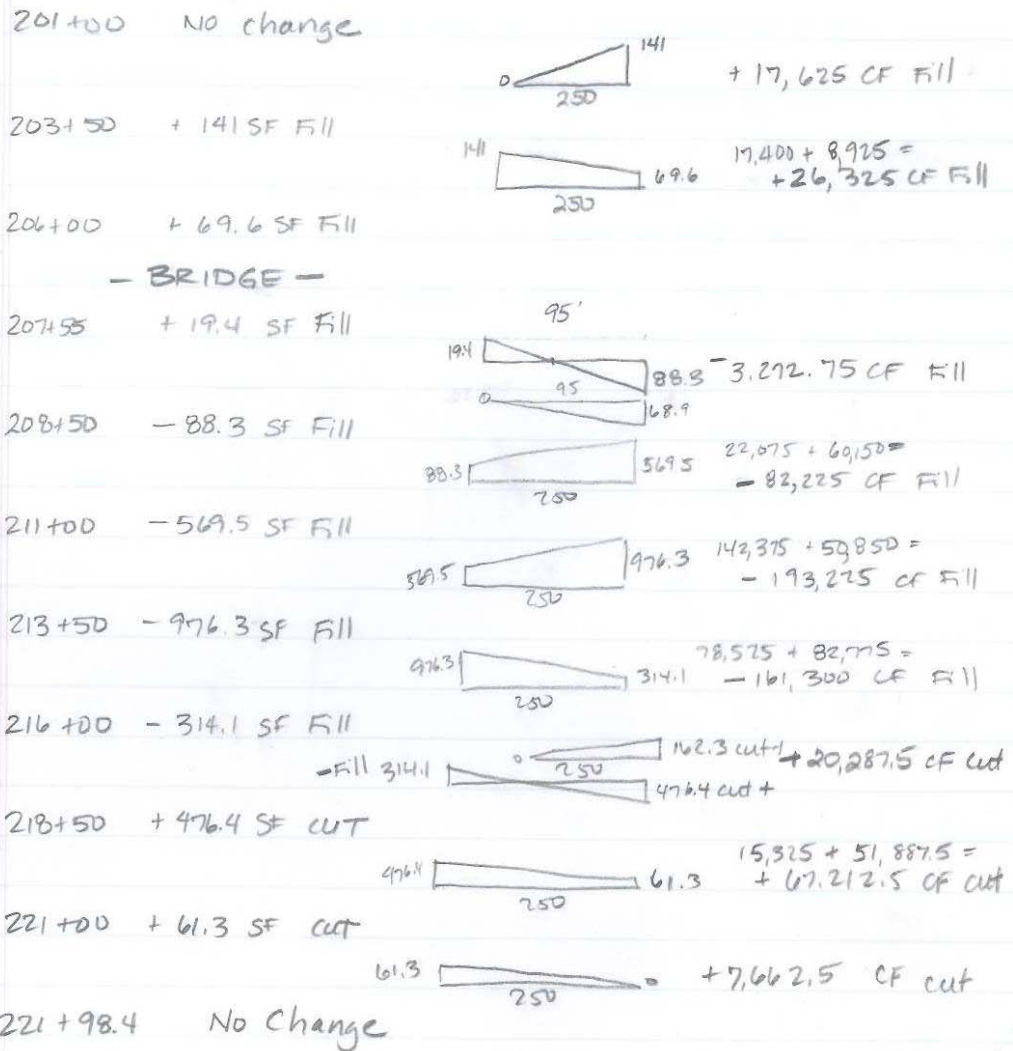

	<u>CUT</u>	<u>FILL</u>
	+ 95,163 CF	- 396,046 CF
	= 3,524 CF	= -14,668 CF
	= +\$17,620	- \$73,340
	<div style="border-top: 1px solid black; width: 100%; margin-top: 5px;"></div>	
	\$55,720 SAVINGS	

COST - @ \$5/CF

CALCULATIONS

Project: SR 142 Widening and Bridge Replacement

Idea No.: C-4
Client: GDOT
Sheet 6 of 7

Reduction in right-of-way every 250-feet along proposed profile from Station 201+00 to 221+98.40:

	<u>RT</u>		<u>LT</u>	
NA	0	201+00	0	
NA	-312.5 SF			-1554' X/A
	-2.5'	203+50	-12.43'	
NA	-312.5 SF			-1554' NA
	0	206+00	0	
	0	— BRIDGE —		0 RR
	0	207+55	0	
	0			0 RR
	0	208+50	0	
② 52'	400 SF			700 ① 35
	-3.2	211+00	-5.6	
②	1637.5 SF <small>800 837.5</small>		1400 675	2015 ①
	-9.9	213+50	-11	
③ 42.25'	3,712.5 SF <small>2475 1237.5</small>		5875 1575	2102.5 ①
	-19.8	216+00	-6.3	
③	2475 SF			787.5 ①
	0	218+50	0	
	0			0
	0	221+00	0	
		221+98.4		
	<u>SF</u>	<u>COST/SF</u>		
Parcel ①	8833	\$5.00	\$44,165	marked by parcel in the encl. sheets / re-orientation x1.1
②	2038	\$12.00	\$24,456	
③	6188	\$2.25	\$13,923	
			\$72,544	

CALCULATIONS

Project: SR 142 Widening and Bridge Replacement

Idea No.: C-14
 Client: GDOT
 Sheet 7 of 7

Reduction in right-of-way every 250-feet along proposed profile from Station 201+00 to 221+98.40:

CONSTRUCTION ELEMENT			ORIGINAL ESTIMATE			NEW ESTIMATE		
ITEM	UNITS	No. UNITS	COST/UNIT	TOTAL COST	No. UNITS	COST/UNIT	TOTAL COST	
Right-of-way Savings:								
Parcel 1	SF	8833	5.00	44,165	0	5.00	0	
Parcel 2	SF	2038	2.00	4,076	0	2.00	0	
Parcel 3	SF	6188	2.50	15,470	0	2.50	0	
Add 10% for Market Appreciation				6,371				
Add 50% for Counter Offers and Condemnation:				3,186				
SUBTOTAL				73,268			0	
TOTAL				73,268			0	
TOTAL ROUNDED				73,270			0	

DEVELOPMENT AND RECOMMENDATION PHASE

SR 142 Widening and Bridge Replacement

IDEA No.: D-3	Sheet No.: 1 of 7	CREATIVE IDEA: Reduce the bridge shoulder width from 10 feet to 8 feet.
-------------------------	-----------------------------	---

Comp By: GCG Date: 08/26/2010 Checked By: KB Date: 08/26/2010

Original Concept:

The width of bridge in the Original Concept is as follows:

- 1.625-foot side barrier
 - 10-foot shoulder
 - 2 x 12-foot lanes
 - 2-foot gutter
 - 8-foot raised median
-
- 45.625 ft from edge of deck to centerline bridge

Overall bridge width = 2 x 45.625 ft = 91.25 ft

Proposed Change:

The proposed change narrows the outside shoulders on the bridge from 10 feet to 8 feet. This change will also reduce the width of the MSE wall by the same amount.

Justification:

The change is compliant with the Georgia Department of Transportation “Bridge and Structure Design Policy Manual,” October 2005 Edition with June 2010 revisions.

COST SUMMARY	INITIAL COST	FUTURE COST	TOTAL L. C. COST SAVINGS
Original	\$1,330,000		
Proposed	\$1,280,000		
Savings	\$50,000		\$50,000
FUTURE COST: – Savings		N/A	N/A
TOTAL PRESENT WORTH SAVINGS			\$50,000

SKETCH

Project: SR 142 Widening and Bridge Replacement

Idea No.: D-3
 Client: GDOT
 Sheet 2 of 7

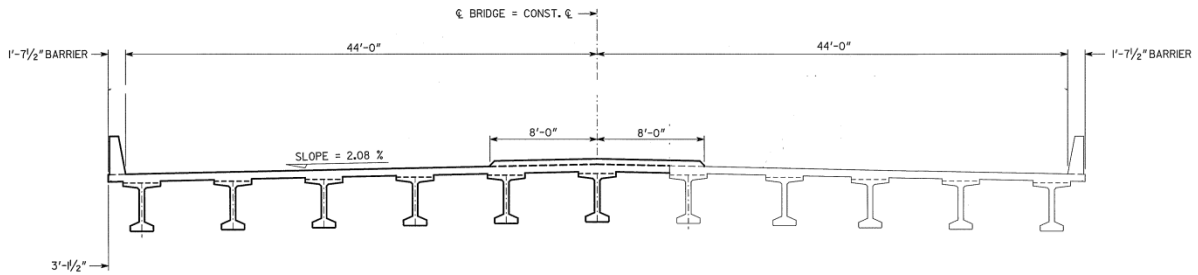

TYPICAL SECTION: ORIGINAL CONCEPT

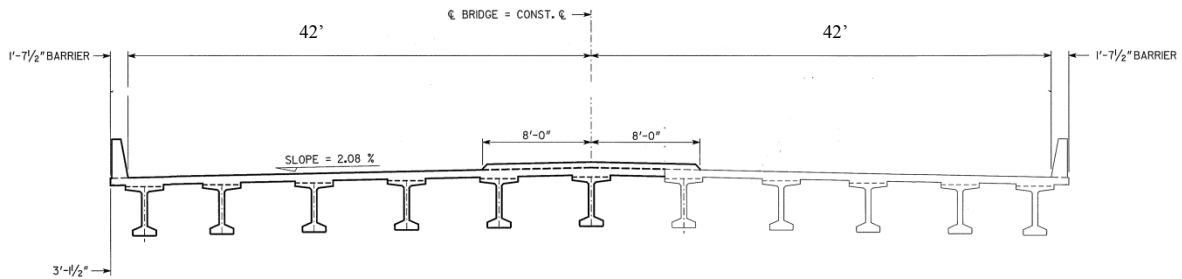

TYPICAL SECTION: PROPOSED CHANGE

CALCULATIONS

Project: SR 142 Widening and Bridge Replacement

Idea No.: D-3
Client: GDOT
Sheet 4 of 7

Proposed Change

From Georgia Department of Transportation “Bridge and Structure Design Policy Manual”, October 2005 Edition with June 2010 revisions, Section 2.9.1 Bridge Width:

- SR 142 is a State Route on the federal system, but is not an Interstate.
- The proposed section is a 4 lane divided roadway
- The section has rural outside shoulders

According to section 2.9.1.1:

Rural section (multilane divided): 4' (inside shoulder +TW+ 8' (outside shoulder)

Therefore:

Use an 8 foot shoulder instead of a 10 foot shoulder.

Cost Comparison

There is not a detailed cost breakdown of the cost of the Original Concept.

The original concept is comprised of 2-MSE retaining walls and the 98 ft long x 91.25 ft wide bridge

The wall areas have been computed to be 4442 ft² each and the bridge is 8,943 ft

Item	Width	Length	Area	\$/ft2	Total
Wall			4442	\$ 44.00	\$ 195,448.00
Wall			4442	\$ 44.00	\$ 195,448.00
Bridge	91.25	98	8943	\$ 105.00	\$ 939,015.00
				Total	\$ 1,329,911.00
				Use	\$ 1,330,000.00

Note: The Unit costs used above are estimated values which when multiplied times the unit quantities arrive at the estimated cost for the Bridge that appears in the Construction Cost Estimate.

CALCULATIONS

Project: SR 142 Widening and Bridge Replacement

Idea No.: D-3
Client: GDOT
Sheet 5 of 7

The Proposed Change would reduce the width of the bridge as follows:

$$2 \text{ sides} \times 2 \text{ feet / side} = 4 \text{ feet wide}$$

$$4 \text{ feet wide} \times 98 \text{ feet long} = 392 \text{ ft}^2$$

So, the area of the Proposed Change bridge is: $98 \text{ feet} \times (91.25 \text{ ft} - 4 \text{ feet}) = 8,551 \text{ ft}^2$

The Proposed Change would also reduce the width of the MSE walls as follows:

$$2 \text{ sides} \times 2 \text{ feet / side} = 4 \text{ feet wide}$$

Height of wall along MSE wall face :

$$H = 23 \text{ ft vertical clearance} - 2 \text{ ft clear under bridge} + 4.75 \text{ ft} \quad (\text{See RR endfill control diagram})$$

(See "MSE Wall Abutment" Sketch, page 6)

Height of wall along wall face, $H = 25.75 \text{ ft}$

Total Wall Area reduced by Proposed Change = 4 feet wide x feet 25.75 ft high x 2 walls

Total Wall Area reduced by Proposed Change = 206 ft^2 (103 ft^2 each wall)

Original Concept: (See sheet 7 for area calculation)

$$\text{Wall 1} = 4442 \text{ ft}^2$$

$$\text{Wall 2} = 4442 \text{ ft}^2$$

Proposed Change::

$$\text{Wall 1} = 4442 \text{ ft}^2 - 103 \text{ ft}^2 = 4,339 \text{ ft}^2$$

$$\text{Wall 2} = 4442 \text{ ft}^2 - 103 \text{ ft}^2 = 4,339 \text{ ft}^2$$

CALCULATIONS

Project: SR 142 Widening and Bridge Replacement

Idea No.: D-3
 Client: GDOT
 Sheet 6 of 7



JOB VE STUDY
 SHEET NO. _____ OF _____
 CALCULATED BY GRANT DATE 8/26/10
 CHECKED BY _____ DATE _____
 SCALE NONE

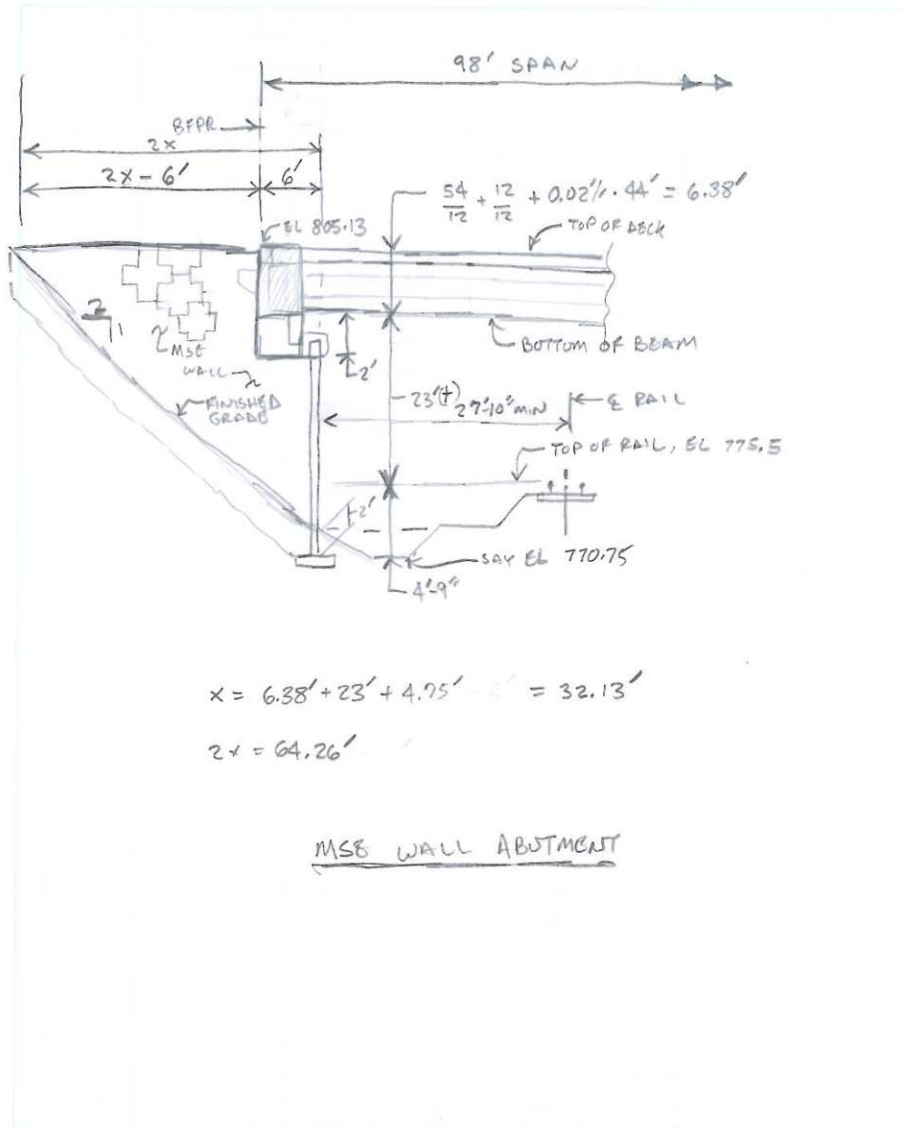

CALCULATIONS

Project: SR 142 Widening and Bridge Replacement

Idea No.: D-3
 Client: GDOT
 Sheet 7 of 7



JOB VE STUDY
 SHEET NO. _____ OF _____
 CALCULATED BY GRANT DATE 8/26/10
 CHECKED BY _____ DATE _____
 SCALE NONE

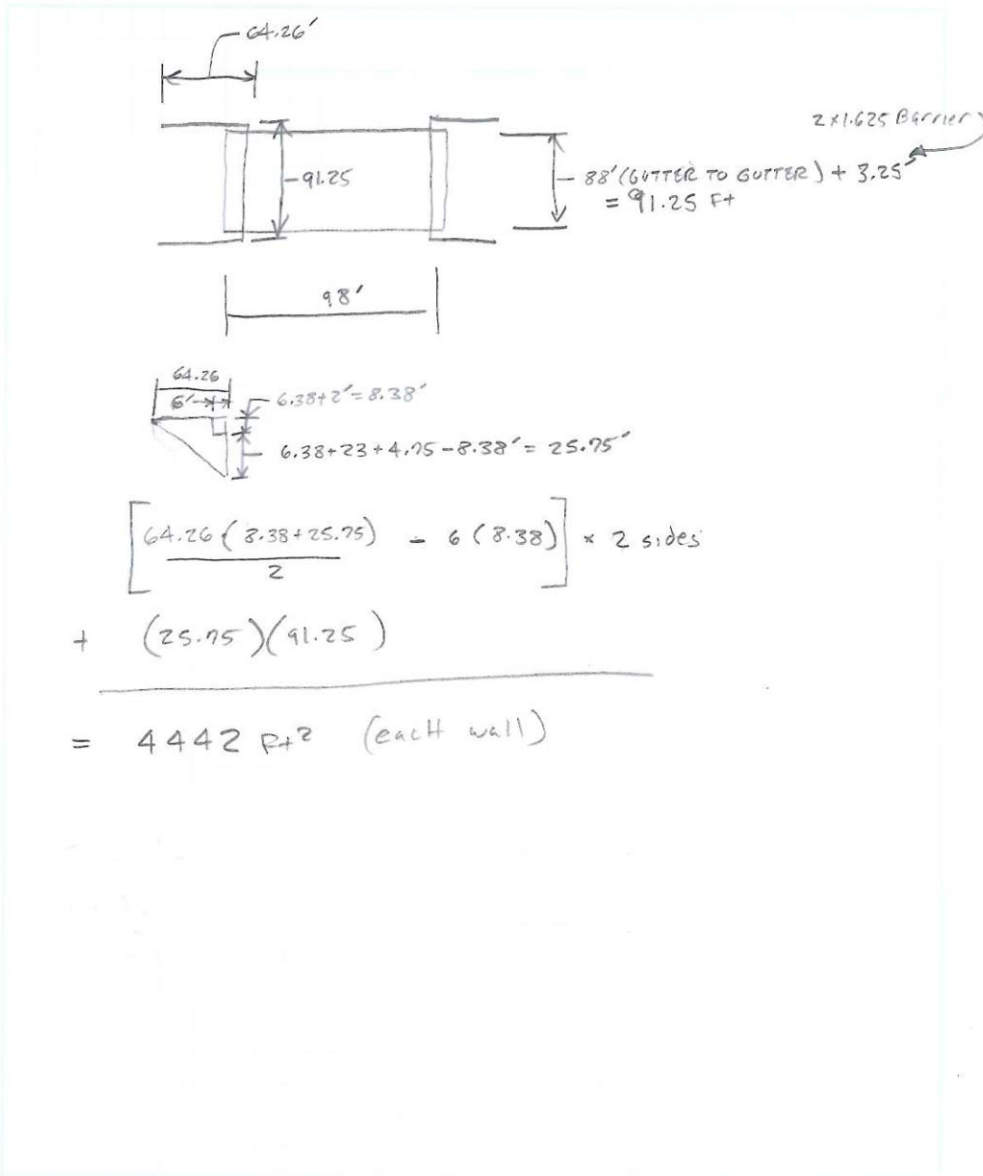

DEVELOPMENT AND RECOMMENDATION PHASE

SR 142 Widening and Bridge Replacement

IDEA No.:
G-3

Sheet No.:
1 of 5

CREATIVE IDEA: Construct a rural roadway section with 10-foot outside shoulders on Alcovy Road south of SR 142.

Comp By: KB Date: 8/24/2010 Checked By: SG Date: 8/25/2010

Original Concept:

The current design for Alcovy Road from Station 1214 to SR 142 is a four-lane urban roadway with a variable width (0 – 20 feet) raised median. The roadway typical section includes a variable width raised median, dual 24-foot roadways, dual 4-foot bike lanes, and dual 12-foot shoulders (curb and gutter, 5-foot sidewalk, and clear area).

Proposed Change:

This recommendation would change the urban roadway typical section to a rural roadway design with outside paved shoulders. The rural typical section would include the same variable width raised median, dual 24-foot roadways, and 10-foot shoulders (6.5 feet paved).

Justification:

Existing Alcovy Road and SR 142 are two-lane rural roadways. Both of these roadways are being reconstructed to divided four-lane roadways. The typical section for the SR 142 new roadway section has 10-foot rural shoulders. The typical section for Alcovy Road north of SR 142 has rural 10-foot shoulders. Only the 2,500 foot section of Alcovy Road south of SR 142 has an urban design with outside curb and gutter and a closed drainage system.

Constructing the southern portion of Alcovy Road with rural 10-foot shoulders would be consistent with the design of the other roadway sections in the project. Constructing a rural roadway section with outside shoulders provides space for the bike lanes on the shoulders in-lieu-of constructing them as part of the full-depth pavement section. Constructing the rural section eliminates the need to construct a closed drainage system and sidewalks. None of the

COST SUMMARY	INITIAL COST	FUTURE COST	TOTAL L. C. COST SAVINGS
Original	\$442,000		
Proposed	\$96,000		
Savings	\$346,000		\$346,000
FUTURE COST: – Savings		N/A	N/A
TOTAL PRESENT WORTH SAVINGS			\$346,000

CONTINUATION

Project: SR 142 Widening and Bridge Replacement

Idea No.: G-3
Client: GDOT
Sheet 2 of 5

other roadway typical sections on this project include an urban design with closed drainage systems and sidewalks. The area where this project is located is industrial and therefore unlikely to have significant pedestrian traffic. There are currently only two commercial buildings having access to this section of Alcovy Road on the east side of the roadway and none on the west side of the roadway. This concept will require the construction of ditches along both sides of the roadway.

SKETCH

Project: SR 142 Widening and Bridge Replacement

Idea No.: G-3
Client: GDOT
Sheet 3 of 5



COST WORKSHEET

Project: SR 142 Widening and Bridge Replacement

Idea No.: G-3
 Client: GDOT
 Sheet 4 of 5

CONSTRUCTION ELEMENT		ORIGINAL ESTIMATE			NEW ESTIMATE		
Item	Unit	No. Units	Cost/Unit	Total Cost	No. Units	Cost/Unit	Total Cost
Current Design:							
Curb & Gutter Type 2	LF	5,219	\$20.00	\$104,380			
GAB Under C & G	SY	1,740	\$10.94	\$19,036			
18" Drain Pipe	LF	1,380	\$46.84	\$64,639			
Catch Basins	Ea	14	\$2,745	\$38,430			
5-foot Sidewalk	SY	2,830	\$40.00	\$113,200			
Bike Lane Pavement	SY	2,264	\$45.00	\$101,880			
VE Design:							
6.5 ft Asphalt Shoulder	SY				3,670	\$18.00	\$66,222
Ditch Excavation	LS				1	\$30,000	\$30,000
SUBTOTAL				\$441,565			\$96,222
TOTAL ROUNDED				\$442,000			\$96,000

CALCULATIONS

Project: SR 142 Widening and Bridge Replacement

Idea No.: G-3
Client: GDOT
Sheet 5 of 5

Cost of Asphalt Pavement: SR 142: 10 ½ inches on 12 inches of GAB

$$(1.5 \text{ in} / 12 \text{ ft}) \times (150 \text{ \#} / \text{CF}) \times (1 \text{ Ton} / 2,000 \text{ \#}) = 0.009375 \text{ Ton} / \text{SF}$$

$$(2.0 \text{ in} / 12 \text{ ft}) \times (150 \text{ \#} / \text{CF}) \times (1 \text{ Ton} / 2,000 \text{ \#}) = 0.0125 \text{ Ton} / \text{SF}$$

$$(7.0 \text{ in} / 12 \text{ ft}) \times (150 \text{ \#} / \text{CF}) \times (1 \text{ Ton} / 2,000 \text{ \#}) = 0.04375 \text{ Ton} / \text{SF}$$

$$(12 \text{ in} / 12 \text{ ft}) \times (135 \text{ \#} / \text{CF}) \times (1 \text{ Ton} / 2,000 \text{ \#}) = 0.0675 \text{ Ton} / \text{SF}$$

Cost per SY

$$(0.009375 \text{ Ton} / \text{SY} \times 9 \text{ SF} / \text{SY} \times \$61.84 / \text{Ton}) = \$5.22$$

$$(0.0125 \text{ Ton} / \text{SY} \times 9 \text{ SF} / \text{SY} \times \$59.17 / \text{Ton}) = \$6.66$$

$$(0.04375 \text{ Ton} / \text{SY} \times 9 \text{ SF} / \text{SY} \times \$55.37 / \text{Ton}) = \$21.80$$

$$(0.0675 \text{ Ton} / \text{SY} \times 9 \text{ SF} / \text{SY} \times \$18.00 / \text{Ton}) = \$10.94$$

$$\text{Cost} = \$5.22 + \$6.66 + \$21.80 + \$10.94 = \$44.62 / \text{SY} \quad \text{Use } \mathbf{\$45.00}$$

Cost of Standard Asphalt Shoulder: 3 ½ inches on 6 inches of GAB

$$(0.009375 \text{ Ton} / \text{SY} \times 9 \text{ SF} / \text{SY} \times \$61.84 / \text{Ton}) = \$5.22$$

$$(0.0125 \text{ Ton} / \text{SY} \times 9 \text{ SF} / \text{SY} \times \$59.17 / \text{Ton}) = \$6.66$$

$$(0.0675 \text{ Ton} / \text{SY} \times 9 \text{ SF} / \text{SY} \times \$18.00 / \text{Ton}) \times \frac{1}{2} = \$5.97$$

$$\text{Cost} = \$5.22 + \$6.66 + \$5.97 = \$17.85 / \text{SY} \quad \text{Use } \mathbf{\$18.00}$$

Alcovy Road Section: Station 1214+00 – 1239+47 = 2,547 ft.

Outside Curb & Gutter:

$$\text{East Side} = 2,547 \text{ ft} + 45 \text{ ft} + 20 \text{ ft} + 60 \text{ ft} = 2,672 \text{ ft}$$

$$\text{West Side} = 2,547 \text{ ft}$$

$$\text{Total C\&G} = 2,547 \text{ ft} + 2,672 \text{ ft} = 5,219 \text{ ft} @ \$20.00 = \$104,380$$

$$\text{GAB under C \& G} = 3 \text{ ft} \times 5,219 \text{ ft} = 15,657 \text{ SF} / 9 = 1,740 \text{ SY} @ \$10.94 = \$19,036$$

18" Drain pipe: 240 ft + 240 ft + 100 ft + 20 ft + 600 ft + 120 ft + 60 ft = 1,380 ft
1,380 ft @ \$46.84 = \$64,639

Catch Basins: 14 @ \$2,745 = \$38,430

5-foot Sidewalk: 2,547 ft x 5 ft = 25,470 SF / 9 = 2,830 SY @ \$40.00 = \$113,200

Bike Lane Pavement: 2 x 4 ft x 2,547 ft = 20,376 SF / 9 = 2,264 SY
2,264 SY @ \$45.00 = \$101,880

New Asphalt Shoulders: 2 x 6.5 ft x 2,547 ft = 33,111 SF / 9 = 3,679 SY
3,679 SY @ \$18.00 = \$66,222

Excavation for ditches: Assume \$30,000 Lump Sum

DEVELOPMENT AND RECOMMENDATION PHASE

SR 142 Widening and Bridge Replacement

IDEA No.: A-4	Sheet No.: 1 of 1	CREATIVE IDEA: <u>Design Consideration</u> Reduce the width of the Temporary R/W Easements.
-------------------------	-----------------------------	---

Comp By: SG Date: 08/25/2010 Checked By: KB Date: 08/25/2010

Original Concept:

The current design shows many locations where temporary R/W easements are being acquired to construct the project.

Proposed Change:

Consideration should be given to reducing the size of the temporary R/W easements throughout the project.

Justification:

Many of the temporary R/W easements extend well past the project limits. Since the project's design is more defined, a review of the need for temporary R/W easements should be made to determine the size needed to construct the project. Reducing the size of the easements would reduce the cost of the project.

COST SUMMARY	INITIAL COST	FUTURE COST	TOTAL L. C. COST SAVINGS
Original	Design Consideration		
Proposed			
Savings			
FUTURE COST: – Savings			
TOTAL PRESENT WORTH SAVINGS			Design Consideration

DEVELOPMENT AND RECOMMENDATION PHASE

SR 142 Widening and Bridge Replacement

IDEA No.: B-1 & 3	Sheet No.: 1 of 1	CREATIVE IDEA: <u>Design Consideration</u> Pavement design / selection for the project.
-----------------------------	-----------------------------	---

Comp By: SG Date: 08/25/2010 Checked By: KB Date: 08/25/2010

Original Concept: The original pavement design for the proposed project is asphalt concrete pavement with partial depth shoulders. A new pavement type selection / design was provided to the VE team at the design briefing stating the preferred alternate is full depth PC concrete pavement.

Proposed Change: Consideration should be given to constructing the project with asphalt concrete pavement.

Justification:

Asphalt pavement advantages specific to this project:

- Maintains consistency of pavement type with the existing sections at both ends of the project, including the recently completed section from I-20 to the south end of this project.
- This short (1.5 miles) project is more suitable for asphalt pavement since it is unlikely that a long adjacent section of SR 142 will be widened to the north anytime soon.
- The material is more conducive when constructing short sections of roadway while maintaining multiple driveway access to local industries.
- Quicker to place and open to traffic (no forming and curing).
- Simplifies staging and traffic control in an industrial area with many driveways.
- Simplifies paving to 68-foot wide section (part to be stripped out) after the raised median is dropped south of Sims Chapel Road.

Asphalt pavement disadvantages:

- Higher Life Cycle Cost although pavement rehab and resurfacing is more efficient than concrete

COST SUMMARY	INITIAL COST	FUTURE COST	TOTAL L. C. COST SAVINGS
Original	Design Consideration		
Proposed			
Savings			
FUTURE COST: – Savings			
TOTAL PRESENT WORTH SAVINGS			Design Consideration

APPENDIX

Sources

Approving/Authorizing Persons

Name:	Position:	Telephone:
Ron Wishon	Engineering Services	404-631-1753
Jill Franks	Project Engineer – Roadway Design	404-631-1726

Personal Contacts

Name:	Telephone:	Notes:
Jill Franks	404-631-1726	Project Design Briefing
Lawra Rish	404-631-1415	Environmental Assessment
Jill Franks	404-631-1726	Discussion on pavement type, signalization, airport request
Jill Franks	404-631-1726	Bike Paths

Documents/Abstracts

Reference:	Reference:
100 Scale Layout Sheet	Project Concept Report
Cost Estimate	Revised Project Concept Report
Environmental Assessment	VE Consideration / Constraint Form
Pavement Design Report	Preliminary Bridge Layout
30% Plans	Preliminary Cross Sections
Intersection Traffic Projections	Existing Bridge Plans
Roadway grade / alignment files	

FAST DIAGRAM

SR 142 – Widening

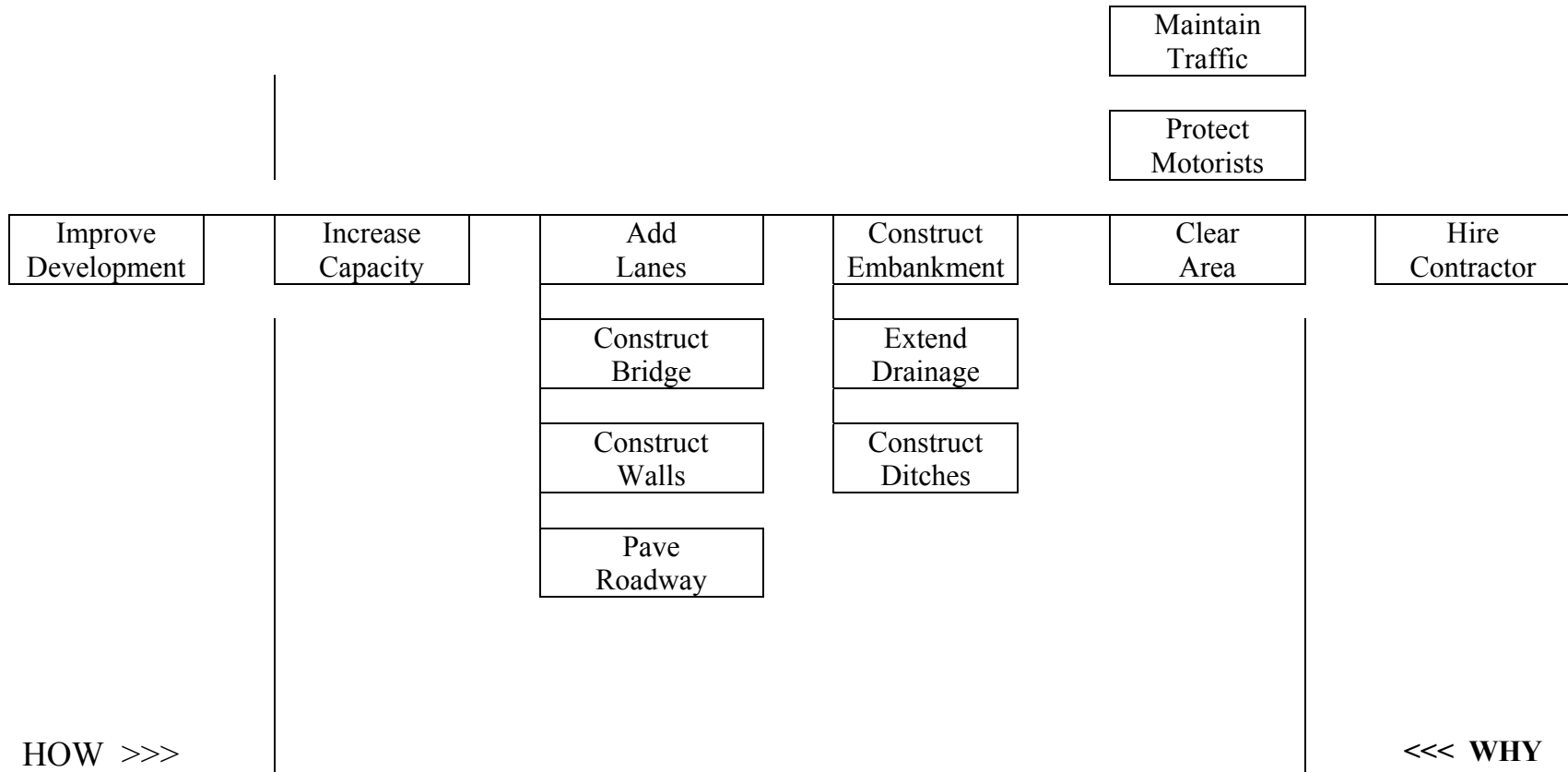

INFORMATION PHASE – FUNCTION ANALYSIS

Project: SR 142 Widening & Bridge Reconstruction

Function: Increase Capacity

ITEM No.	DESCRIPTION	FUNCTION		INITIAL DOLLARS		
		Verb	Noun	Cost	% of Total	Worth/Save
A	Right of Way	Store	Project	\$4,280,000	27.8%	Yes
		Allow	Widening			
		Allow	Erosion Control			
B	Pavement (Asphalt Option)	Provide	Surface	\$3,199,000	20.8%	Yes
		Support	Loads			
		Add	Lanes			
		Provide	Continuity			
		Mill / Resurface	Existing			
		Accommodate	Bike Lanes			
C	Grading Complete	Construct	Roadway	\$2,200,000	14.3%	Yes
		Construct	Approaches			
		Adjust	Road Grade			
		Construct	Sediment Basins			
		Construct	Ditches			

INFORMATION PHASE – FUNCTION ANALYSIS

Project: SR 142 Widening & Bridge Reconstruction

Function: Increase Capacity

ITEM No.	DESCRIPTION	FUNCTION		INITIAL DOLLARS		
		Verb	Noun	Cost	% of Total	Worth/Save
D	Bridge	Span	Railroad	\$1,330,000	8.6%	Yes
		Accommodate	New Track			
		Avoid	Power Lines			
		Cross	RR Frontage Rd			
E	Aggregate Base Course	Support	Roadway	\$1,257,000	8.2%	No
		Provide	Drainage			
F	Traffic Control	Stage	Construction	\$1,000,000	6.5%	No
		Maintain	Traffic			
		Protect	Workers			
G	Drainage	Extend	Existing	\$464,000	3.0%	Yes
H	Erosion Control	Control	Sediment	\$459,000	3.0%	No
		Control	Runoff			
		Protect	Slopes			

INFORMATION PHASE – FUNCTION ANALYSIS

Project: SR 142 Widening & Bridge Reconstruction

Function: Increase Capacity

ITEM No.	DESCRIPTION	FUNCTION		INITIAL DOLLARS		
		Verb	Noun	Cost	% of Total	Worth/Save
I	Miscellaneous	Construct	Project	\$410,000	2.7%	No
J	Curb & Gutter (30") Type 2 & 7	Control	Water	\$320,000	2.1%	Yes
		Separate	Traffic			
		Limit	Access			
		Connect	Existing			
K	Signals	Advise	Motorists	\$166,000	1.1%	Yes
		Control	Movements			
		Upgrade	Existing			
L	Concrete Medial (4" and 6")	Separate	Traffic	\$146,000	0.9%	Yes
		Control	Access			
		Fill	Medians			
M	Concrete Sidewalk	Connect	Existing	\$96,000	0.6%	No
		Accommodate	Pedestrians			

CREATIVE PHASE Creative Idea Listing		JUDGMENT PHASE Idea Evaluation	
No.	CREATIVE IDEA	COMMENTS	IDEA RATING
A	R/W		
A-1	Shorten the project length along SR 142 @ Airport.	See Idea B-4	X
A-2	Extend the Bridge MSE Wall Embankment.	See Idea C-1	X
A-3	Reduce / Eliminate the size of the sediment basins.	Reduce Cost, Simplify Construction	✓
A-4	Reduce the width of the Temporary Easements in several areas. (Station 1402 – 1403)	Reduce amount of R/W required for the project, add additional slope.	✓
A-5	Shorten the length of Alcovy Road east of SR 142.	See Idea B-2	X
A-6	Reduce / modify the number of lanes / turn lanes on Alcovy Road at the Avenue of Champions.	See Idea B-2	X
B	Pavement		
B-1	Construct the project with Asphalt Pavement.	Simplify Construction, Match existing roadway	DS
B-2	Reduce the number of lanes on Alcovy Road north of the Avenue of Champions.	Reduce cost, Reduce R/W,	✓
B-3	Eliminate full depth shoulders for either the asphalt or PC pavement options..	Reduce cost	DS
B-4	Shorten the length of SR 142 along the airport area.	Reduce cost, Reduce Impacts, Simplify Const.	✓
✓ = Will be considered further; X = will be dropped; DS = Design suggestion –written for consideration by design team			

CREATIVE PHASE Creative Idea Listing		JUDGMENT PHASE Idea Evaluation	
No.	CREATIVE IDEA	COMMENTS	IDEA RATING
B-5	Construct Bike lanes on SR 142 but not Alcovy Road.	Question if on County Bike Plan	✓
B-6	Reduce pavement width on SR 142 as it approaches Sims Chapel Road (68 feet wide).	Reduce cost, reduce R/W, Reduce impact on wetlands.	✓
B-7	Reduce lane widths from 12 feet to 11 feet.	Not practical in industrial area, Match existing	X
C	Grading Complete		
C-1	Extend the length of the MSE wall at the bridge to reduce the amount of embankment.	Reduce R/W, Reduce roadway embankment.	✓
C-2	Adjust the roadway profile.	See Idea C-3	X
C-3	Reduce the design speed to 45 MPH and adjust the roadway profile.	Match roadway typical (20' raised median, save cost, reduce clear zone requirements, Save R/W	✓
C-4	Maintain the 55 MPH design speed and use the minimum K vales for the vertical curve at the railroad bridge.	Reduce roadway profile, Reduce embankment,	✓
C-5	Eliminate the grade change at the airport.	Question if roadway is in the glide path.	DS
D	Bridge		
D-1	Use smaller beams and reduce the roadway elevation.	Not practical due to span length.	X
✓ = Will be considered further; X = will be dropped; DS = Design suggestion –written for consideration by design team			

CREATIVE PHASE Creative Idea Listing		JUDGMENT PHASE Idea Evaluation	
No.	CREATIVE IDEA	COMMENTS	IDEA RATING
D-2	Construct a 2-span bridge in-lieu-of a single span bridge.	Possible cost reduction	✓
D-3	Reduce the width of the shoulders on the bridge.	Reduce cost	✓
D-4	Reduce the lane width from 12 feet to 11 feet.	Not practical in industrial area, Match existing	X
G	Drainage		
G-1	Eliminate the drainage being dumped into the railroad R/W.		DS
G-2	Reduce the design speed to 45 MPH.	See Idea C-3	X
G-3	Eliminate the closed drainage system on Alcovy Road west of SR 142.	Reduce drainage cost, provide bike lane on outside shoulder. Reduce curb & gutter.	✓
J	Curb and Gutter (30") Type 2 & 7		
J-1	Eliminate the curb and gutter section on Alcovy Road west of SR 142.	See Idea G-3	X
K	Signals		
K-1	Why are 12 strain poles needed for one signalized intersection?	Four poles for signals and eight poles for signs on roadway approaches.	X
✓ = Will be considered further; X = will be dropped; DS = Design suggestion –written for consideration by design team			

