



**GRE**

GRADUATE RECORD EXAMINATIONS®

# Biology Test Practice Book

## This practice book contains

- one actual full-length GRE Biology Test
- test-taking strategies

## Become familiar with

- test structure and content
- test instructions and answering procedures

Compare your practice test results with the performance of those who took the test at a GRE administration.

Visit GRE Online at [www.gre.org](http://www.gre.org)

*Listening.  
Learning.  
Leading.*

This book is provided **FREE** with test registration by the Graduate Record Examinations Board.

Note to Test Takers: Keep this practice book until you receive your score report.  
The book contains important information about content specifications and scoring.

Copyright © 2001 by Educational Testing Service. All rights reserved.  
EDUCATIONAL TESTING SERVICE, ETS, the ETS logos, GRADUATE RECORD EXAMINATIONS,  
and GRE are registered trademarks of Educational Testing Service.

## Table of Contents

Purpose of the GRE Subject Tests .....	3
Development of the Subject Tests .....	3
Content of the Biology Test .....	4
Preparing for a Subject Test .....	7
Test-Taking Strategies .....	7
What Your Scores Mean .....	8
Practice Biology Test .....	11
Scoring Your Subject Test .....	65
Evaluating Your Performance .....	68
Answer Sheet .....	69

### Purpose of the GRE Subject Tests

The GRE Subject Tests are designed to help graduate school admission committees and fellowship sponsors assess the qualifications of applicants in specific fields of study. The tests also provide you with an assessment of your own qualifications.

Scores on the tests are intended to indicate knowledge of the subject matter emphasized in many undergraduate programs as preparation for graduate study. Because past achievement is usually a good indicator of future performance, the scores are helpful in predicting success in graduate study. Because the tests are standardized, the test scores permit comparison of students from different institutions with different undergraduate programs. For some Subject Tests, subscores are provided in addition to the total score; these subscores indicate the strengths and weaknesses of your preparation, and they may help you plan future studies.

The GRE Board recommends that scores on the Subject Tests be considered in conjunction with other relevant information about applicants. Because numerous factors influence success in graduate school, reliance on a single measure to predict success is not advisable. Other indicators of competence typically include undergraduate transcripts showing courses taken and grades earned, letters of recommendation, the GRE Writing Assessment score, and GRE General Test scores. For information about the appropriate use of GRE scores, write to GRE Program, Educational Testing Service, Mail Stop 57-L, Princeton, NJ 08541, or visit our Web site at [www.gre.org/codelst.html](http://www.gre.org/codelst.html).

### Development of the Subject Tests

Each new edition of a Subject Test is developed by a committee of examiners composed of professors in the subject who are on undergraduate and graduate faculties in different types of institutions and in different regions of the United States and Canada. In selecting members for each committee, the GRE Program seeks the advice of the appropriate professional associations in the subject.

The content and scope of each test are specified and reviewed periodically by the committee of examiners. Test questions are written by the committee and by other faculty who are also subject-matter specialists and by subject-matter specialists at ETS. All questions proposed for the test are reviewed by the committee and revised as necessary. The accepted questions are assembled into a test in accordance with the content specifications developed by the committee to ensure adequate coverage of the various aspects of the field and, at the same time, to prevent overemphasis on any single topic. The entire test is then reviewed and approved by the committee.

Subject-matter and measurement specialists on the ETS staff assist the committee, providing information and advice about methods of test construction and helping to prepare the questions and assemble the test. In addition, each test question is reviewed to eliminate language, symbols, or content considered potentially offensive, inappropriate for major subgroups of the test-taking population, or likely to perpetuate any negative attitude that may be conveyed to these subgroups. The test as a whole is also reviewed to ensure that the test questions, where applicable, include an appropriate balance of people in different groups and different roles.

Because of the diversity of undergraduate curricula, it is not possible for a single test to cover all the material you may have studied. The examiners, therefore, select questions that test the basic knowledge and skills most important for successful graduate study in the particular field. The committee keeps the test up-to-date by regularly developing new editions and revising existing editions. In this way, the test content changes steadily but gradually, much like most curricula. In addition, curriculum surveys are conducted periodically to ensure that the content of a test reflects what is currently being taught in the undergraduate curriculum.

After a new edition of a Subject Test is first administered, examinees' responses to each test question are analyzed in a variety of ways to determine whether each question functioned as expected. These analyses may reveal that a question is ambiguous, requires knowledge beyond the scope of the test, or is inappropriate for the total group or a particular subgroup of examinees taking the test. Answers to such questions are not used in computing scores.

Following this analysis, the new test edition is equated to an existing test edition. In the equating process, statistical methods are used to assess the difficulty of the new test. Then scores are adjusted so that examinees who took a difficult edition of the test are not penalized, and examinees who took an easier edition of the test do not have an advantage. Variations in the number of questions in the different editions of the test are also taken into account in this process.

Scores on the Subject Tests are reported as three-digit scaled scores with the third digit always zero. The maximum possible range for all Subject Test total scores is from 200 to 990. The actual range of scores for a particular Subject Test, however, may be smaller. The maximum possible range of Subject Test subscores is 20 to 99; however, the actual range of subscores for any test or test edition may be smaller than 20 to 99. Subject Test score interpretive information is provided in *Interpreting Your GRE Scores*, which you will receive with your GRE score report, and on the GRE Web site at [www.gre.org/codelst.html](http://www.gre.org/codelst.html).

## Content of the Biology Test

The test contains about 200 five-choice questions, a number of which are grouped in sets toward the end of the test and are based on descriptions of laboratory and field situations, diagrams, or experimental results.

To cover the broad field of the biological sciences, the subject matter on which the students are tested is organized into three major areas: cellular and molecular biology; organismal biology; and ecology and evolution. Approximately equal weight is given to each of these three areas. However, subject area subdivisions indicated by Arabic numerals may not contain equal numbers of questions.

The approximate distribution of questions by content category is shown below.

### I. Cellular and Molecular Biology 33-34%

Fundamentals of cellular biology, genetics, and molecular biology are addressed. Major topics in cellular structure and function include metabolic pathways and their regulation, membrane dynamics, cell surfaces, organelles, cytoskeleton, and cell cycle. Major areas in genetics and molecular biology include chromatin and chromosomal structure, genomic organization and maintenance, and the regulation of gene expression. The cellular basis of immunity, the mechanisms of antigen-antibody interactions, and cell-pathogen interactions are included. Distinctions between prokaryotic and eukaryotic cells are considered where appropriate. Attention is also given to experimental methodology.

- A. Cellular Structure and Function 16-17%
1. Biological compounds
    - Macromolecular structure and bonding
    - Abiotic origin of biological molecules
  2. Enzyme activity, receptor binding, and regulation
  3. Major metabolic pathways and regulation
    - Respiration, fermentation, and photosynthesis
    - Synthesis and degradation of macromolecules
    - Hormonal control and intracellular messengers
  4. Membrane dynamics and cell surfaces
    - Transport, endocytosis, and exocytosis
    - Electrical potentials and neurotransmitters
    - Mechanisms of cell recognition, cell junctions, and plasmodesmata
    - Cell wall and extracellular matrix
  5. Organelles: structure, function, and targeting
  6. Cytoskeleton, motility, and shape
    - Actin-based systems
    - Microtubule-based systems
    - Intermediate filaments
    - Bacterial flagella and movement
  7. Cell cycle, growth, division, and regulation
- B. Genetics and Molecular Biology 16-17%
1. Genetic foundations
    - Mendelian inheritance; Pedigree analysis
    - Prokaryotic genetics (transformation, transduction, and conjugation)
    - Genetic mapping
  2. Chromatin and chromosomes
    - Nucleosomes
    - Karyotypes
    - Chromosomal aberrations
    - Polytene chromosomes
  3. Genome sequence organization
    - Introns and exons; Single-copy and repetitive DNA
    - Transposable elements
  4. Genome maintenance
    - DNA replication; DNA mutation and repair
  5. Gene expression and regulation in prokaryotes and eukaryotes: mechanisms
    - The operon; Promoters and enhancers;
    - Transcription factors; RNA and protein synthesis; Processing and modifications of both RNA and protein

6. Gene expression and regulation: effects
  - Control of normal development; Cancer and oncogenes
  - Signaling mechanisms in cells
7. Immunobiology
  - Cellular basis of immunity; Antibody diversity and synthesis
  - Antigen-antibody interactions
8. Bacteriophages, animal viruses, and plant viruses
  - Viral genomes, replication, and assembly
  - Virus-host cell interactions
9. Recombinant DNA methodology
  - Restriction endonucleases; Blotting and hybridization
  - Restriction fragment length polymorphisms; DNA cloning, sequencing, and analysis; Polymerase chain reaction

## II. Organismal Biology 33-34%

The structure, physiology, behavior, and development of plants and animals are addressed. Topics covered include nutrient procurement and processing, gas exchange, internal transport, regulation of fluids, control mechanisms and effectors, and reproduction in autotrophic and heterotrophic organisms. Examples of developmental phenomena range from fertilization through differentiation and morphogenesis. Perceptions and responses to environmental stimuli are examined as they pertain to both plants and animals. Major distinguishing characteristics and phylogenetic relationships of selected groups from the various kingdoms are also covered.

- A. Animal Structure, Function, and Organization 9-10%
1. Exchange with environment
    - Nutrient, salt, and water exchange
    - Gas exchange; Energy
  2. Internal transport and exchange
    - Circulatory, gastrovascular, and digestive systems
  3. Support and movement
    - Support systems (external, internal, and hydrostatic)
    - Movement systems (flagellar, ciliary, and muscular)
  4. Integration and control mechanisms
    - Nervous and endocrine systems

5. Behavior (communication, orientation, learning, and instinct)
  6. Metabolic rates (temperature, body size, and activity)
- B. Animal Reproduction and Development 5-6%
1. Reproductive structures
  2. Meiosis, gametogenesis, and fertilization
  3. Early development (e.g., polarity, cleavage, and gastrulation)
  4. Developmental processes (e.g., induction, determination, differentiation, morphogenesis, and metamorphosis)
  5. External control mechanisms (e.g., photoperiod)
- C. Plant Structure, Function, and Organization, with Emphasis on Flowering Plants 6-7%
1. Tissues, tissue systems, and organs
  2. Water transport, including absorption and transpiration
  3. Phloem transport and storage
  4. Mineral nutrition
  5. Plant energetics (e.g., respiration and photosynthesis)
- D. Plant Reproduction, Growth, and Development, with Emphasis on Flowering Plants 4-5%
1. Reproductive structures
  2. Meiosis and sporogenesis
  3. Gametogenesis and fertilization
  4. Embryogeny and seed development
  5. Meristems, growth, morphogenesis, and differentiation
  6. Control mechanisms (e.g., hormones, photoperiod, and tropisms)
- E. Diversity of Life 6-7%
1. Archaeobacteria  
Morphology, physiology, and identification
  2. Eubacteria (including cyanobacteria)  
Morphology, physiology, pathology, and identification
  3. Protista  
Protozoa, other heterotrophic Protista (slime molds and Oomycota), and autotrophic Protista  
Major distinguishing characteristics  
Phylogenetic relationships  
Importance (e.g., eutrophication, disease)

4. Fungi  
Distinctive features of major phyla (vegetative, asexual, and sexual reproduction)  
Generalized life cycles  
Importance (e.g., decomposition, biodegradation, antibiotics, and pathogenicity)  
Lichens
5. Animalia with emphasis on major phyla  
Major distinguishing characteristics  
Phylogenetic relationships
6. Plantae with emphasis on major phyla  
Alternation of generations  
Major distinguishing characteristics  
Phylogenetic relationships

### III. Ecology and Evolution 33-34%

This section deals with the interactions of organisms and their environment, emphasizing biological principles at levels above the individual. Ecological and evolutionary topics are given equal weight. Ecological questions range from physiological adaptations to the functioning of ecosystems. Although principles are emphasized, some questions may consider applications to current environmental problems. Questions in evolution range from its genetic foundations through evolutionary processes to their consequences. Evolution is considered at the molecular, individual, population, and higher levels. Principles of ecology, genetics, and evolution are interrelated in many questions. Some questions may require quantitative skills, including the interpretation of simple mathematical models.

- A. Ecology 16-17%
1. Environment/organism interaction  
Biogeographic patterns; Adaptations to environment; Temporal patterns
  2. Behavioral ecology  
Habitat selection; Mating systems; Social systems; Resource acquisition
  3. Population structure and function  
Population dynamics/regulation; Demography and life history strategies
  4. Communities  
Interspecific relationships; Community structure and diversity; Change and succession

5. Ecosystems
    - Productivity and energy flow; Chemical cycling
- B. Evolution 16-17%
1. Genetic variability
    - Origins (mutations, linkage, recombination, and chromosomal alterations)
    - Levels (e.g., polymorphism and heritability)
    - Spatial patterns (e.g., clines and ecotypes)
    - Hardy-Weinberg equilibrium
  2. Evolutionary processes
    - Gene flow and genetic drift; Natural selection; Levels of selection (e.g., individual and group)
  3. Evolutionary consequences
    - Fitness and adaptation; Speciation; Systematics and phylogeny; Convergence, divergence, and extinction
  4. History of life
    - Origin of prokaryotic and eukaryotic cells
    - Fossil record
    - Paleontology and paleoecology

## Preparing for a Subject Test

GRE Subject Test questions are designed to measure skills and knowledge gained over a long period of time. Although you might increase your scores to some extent through preparation a few weeks or months before you take the test, last minute cramming is unlikely to be of further help. The following information may be helpful.

- A general review of your college courses is probably the best preparation for the test. However, the test covers a broad range of subject matter, and no one is expected to be familiar with the content of every question.
- Use this practice book to become familiar with the types of questions in the GRE Biology Test, paying special attention to the directions. If you thoroughly understand the directions before you take the test, you will have more time during the test to focus on the questions themselves.

## Test-Taking Strategies

The questions in the practice test in this book illustrate the types of multiple-choice questions in the test. When you take the test, you will mark your answers on a separate machine-scorable answer sheet. Total testing time is two hours and fifty minutes; there are no separately timed sections. Following are some general test-taking strategies you may want to consider.

- Read the test directions carefully, and work as rapidly as you can without being careless. For each question, choose the best answer from the available options.
- All questions are of equal value; do not waste time pondering individual questions you find extremely difficult or unfamiliar.
- You may want to work through the test quite rapidly, first answering only the questions about which you feel confident, then going back and answering questions that require more thought, and concluding with the most difficult questions if there is time.
- If you decide to change an answer, make sure you completely erase it and fill in the oval corresponding to your desired answer.
- Questions for which you mark no answer or more than one answer are not counted in scoring.
- As a correction for haphazard guessing, one-fourth of the number of questions you answer incorrectly is subtracted from the number of questions you answer correctly. It is improbable that mere guessing will improve your score significantly; it may even lower your score. If, however, you are not certain of the correct answer but have some knowledge of the question and are able to eliminate one or more of the answer choices, your chance of getting the right answer is improved, and it may be to your advantage to answer the question.

- Record all answers on your answer sheet. Answers recorded in your test book will not be counted.
- Do not wait until the last five minutes of a testing session to record answers on your answer sheet.

## What Your Scores Mean

Your raw score, that is—the number of questions you answered correctly minus one-fourth of the number you answered incorrectly—is converted to the scaled score that is reported. This conversion ensures that a scaled score reported for any edition of a Subject Test is comparable to the same scaled score earned on any other edition of the same test. Thus, equal scaled scores on a particular Subject Test indicate essentially equal levels of performance regardless of the test edition taken. Test scores should be compared only with other scores on the same Subject Test. (For example, a 680 on the Computer Science Test is not equivalent to a 680 on the Mathematics Test.)

Before taking the test, you may find it useful to know approximately what raw scores would be required to obtain a certain scaled score. Several factors influence the conversion of your raw score to your scaled score, such as the difficulty of the test edition and the number of test questions included in the computation of your raw score. Based on recent editions of the Biology Test, the following table gives the range of raw scores associated with selected scaled scores for three different test editions. (Note that when the number of scored questions for a given test is greater than the range of possible scaled scores, it is likely that two or more raw scores will convert to the same scaled score.) The three test editions in the table that follows were selected to reflect varying degrees of difficulty. Examinees should note that future test editions may be somewhat more or less difficult than those test editions illustrated in the table.

### Range of Raw Scores\* Needed to Earn Selected Scaled Scores on Three Biology Test Editions That Differ in Difficulty

Scaled Score	Raw Scores		
	Form A	Form B	Form C
800	143-145	124-126	118-120
700	113-115	98-99	91-93
600	84-86	71-72	64-66
500	54-56	44-46	37-39
Number of Questions Used to Compute Raw Score			
	200	198	198

\*Raw Score = Number of correct answers minus one-fourth the number of incorrect answers, rounded to the nearest integer.

For a particular test edition, there are many ways to earn the same raw score. For example, on the edition listed above as “Form A,” a raw score of 84 through 86 would earn a scaled score of 600. Below are a few of the possible ways in which a scaled score of 600 could be earned on that edition.

### Examples of Ways to Earn a Scaled Score of 600 on the Edition Labeled as “Form A”

Raw Score	Questions Answered Correctly	Questions Answered Incorrectly	Questions Not Answered	Number of Questions Used to Compute Raw Score
84	84	0	116	200
84	96	47	57	200
84	107	93	0	200
86	86	0	114	200
86	97	45	58	200
86	108	90	2	200



## **Practice Test**

To become familiar with how the administration will be conducted at the test center, first remove the answer sheet (pages 69 and 70). Then go to the back cover of the test book (page 64) and follow the instructions for completing the identification areas of the answer sheet. When you are ready to begin the test, note the time and begin marking your answers on the answer sheet.



GRADUATE RECORD EXAMINATIONS®

GRE®



BIOLOGY TEST

*Do not break the seal  
until you are told to do so.*

*The contents of this test are confidential.  
Disclosure or reproduction of any portion  
of it is prohibited.*

**THIS TEST BOOK MUST NOT BE TAKEN FROM THE ROOM.**

Copyright © 1998, 1999 by Educational Testing Service. All rights reserved.

GRE, GRADUATE RECORD EXAMINATIONS, ETS, EDUCATIONAL TESTING SERVICE and the ETS logo are registered trademarks of Educational Testing Service. The modernized ETS logo is a trademark of Educational Testing Service.

## BIOLOGY TEST

Time—170 minutes

200 Questions

Directions: Each of the questions or incomplete statements below is followed by five suggested answers or completions. Select the one that is best in each case and then completely fill in the corresponding space on the answer sheet.

1. A homozygous, Rh-positive man ( $RR$ ) marries an Rh-negative ( $rr$ ) woman. Their first child is normal, but their second child has hemolytic disease (Rh disease). The first child did not have hemolytic disease because
  - (A) the child was heterozygous ( $Rr$ )
  - (B) the child lacked Rh antigens
  - (C) the mother had a previous blood transfusion that protected the child against her antibodies
  - (D) anti-Rh antibodies present in the mother were destroyed by the child's immune system
  - (E) anti-Rh antibodies were not induced in the mother until the delivery of the first child
2. Which of the following organelles has protein-phospholipid membranes, energy-conversion enzymes, and ribosomes similar to those found in bacteria?
  - (A) Lysosome
  - (B) Peroxisome
  - (C) Rough endoplasmic reticulum
  - (D) Centriole
  - (E) Mitochondrion
3. When DNA replicates semiconservatively, which of the following is true of each daughter DNA molecule?
  - (A) Both strands are newly synthesized.
  - (B) One strand is newly synthesized, whereas the other is a strand from the parent DNA molecule.
  - (C) Both strands are the original strands of the parent molecule.
  - (D) One strand has more AT-rich regions than the other strand has.
  - (E) The newly synthesized strands are more susceptible to melting and renaturation than the parental DNA strands are.
4. Which of the following takes place during anaphase of mitosis in an animal cell?
  - (A) Kinetochore microtubules elongate to push chromosomes toward the metaphase plate.
  - (B) The chromosomes align on the metaphase plate.
  - (C) Sister chromatids remain attached to each other at the centromere and move toward the pole as a unit.
  - (D) The contractile ring completes the process of cytokinesis.
  - (E) Polar microtubules elongate and slide to push the spindle poles apart.
5. Members of which of the following groups CANNOT generate their own ATP?
  - (A) Lichens
  - (B) Bacteria
  - (C) Viruses
  - (D) Diatoms
  - (E) Protozoa
6. The complementary RNA sequence for GATCAA is
  - (A) CTAGTT
  - (B) CUAGUU
  - (C) AGCTGG
  - (D) AGCUGG
  - (E) TCGACC

GO ON TO THE NEXT PAGE.

Unauthorized copying or reuse of  
any part of this test is illegal.

7. Which of the following would best demonstrate that the genomes of differentiated cells are genetically equivalent?
- (A) Isolation and culture of blastomeres of two- or four-celled embryos
  - (B) Isolation and culture of nuclei in the presence of cells from which they have been removed
  - (C) Isolation and fusion of two different somatic cell types
  - (D) Injection of a nucleus isolated from an adult cell into an egg from which the nucleus has been removed
  - (E) Injection of an intact somatic cell into an egg from which the nucleus has been removed
8. All of the following mechanisms have been shown experimentally to contribute to the formation of cancer cells EXCEPT
- (A) abnormally high energy reserves in cancer cells that cause them to divide too quickly
  - (B) mutations that cause excess production of growth factors by cancer cells
  - (C) mutations that reduce the need for growth factors in cancer cells
  - (D) mutations that inactivate genes that normally inhibit cell division
  - (E) viruses that carry genes that transform normal cells into cancer cells
9. In vascular plants, DNA is contained in which of the following?
- I. Nucleus
  - II. Chloroplast
  - III. Mitochondrion
- (A) I only
  - (B) II only
  - (C) I and II only
  - (D) II and III only
  - (E) I, II, and III
10. When DNA is extracted from cells of *E. coli* and analyzed for base composition, it is found that 38 percent of the bases are cytosine. What percentage of the bases are adenine?
- (A) 12%
  - (B) 24%
  - (C) 38%
  - (D) 62%
  - (E) 76%
11. Which of the following statements is LEAST likely to be true of mutations in a diploid organism such as the fruit fly?
- (A) Some loci are more mutable than others.
  - (B) X-rays can produce mutations.
  - (C) Some mutations can affect the activity of several genes.
  - (D) Some mutations can have a lethal effect.
  - (E) Most somatic mutations markedly alter the organism's phenotype.
12. The addition of colchicine to a culture of actively dividing flagellated eukaryotic cells inhibits all of the following EXCEPT
- (A) movement of flagella
  - (B) growth of flagella
  - (C) formation of the mitotic apparatus
  - (D) formation of the microtubular cytoskeleton
  - (E) polymerization of tubulin

GO ON TO THE NEXT PAGE.

13. In enzyme-mediated reactions, enzyme molecules are capable of all of the following EXCEPT
- (A) altering the equilibrium of the chemical reaction
  - (B) decreasing the activation energy of the reaction
  - (C) increasing the rate of the reaction
  - (D) binding of molecules other than substrate molecules
  - (E) showing specificity of binding for substrate molecules
14. The cDNA fragment that includes the ricin gene is 5.7 kilobases. If the entire fragment codes for the ricin polypeptide, the approximate number of amino acids in the polypeptide would be
- (A) 17,100
  - (B) 5,700
  - (C) 2,500
  - (D) 1,900
  - (E) 570
15. Members of which of the following classes of macromolecules are known to exhibit enzymelike (catalytic) properties?
- I. RNA
  - II. Glycoproteins
  - III. Lipoproteins
  - IV. Polysaccharides
- (A) I and II only
  - (B) II and III only
  - (C) III and IV only
  - (D) I, II, and III only
  - (E) I, II, III, and IV
16. Which of the following statements is NOT characteristic of all viruses with DNA genomes?
- (A) Replication occurs only in a living cell.
  - (B) Replication involves translation on cellular ribosomes.
  - (C) The viral nucleocapsid is surrounded by a lipid envelope.
  - (D) The viral genome is surrounded by a protein coat.
  - (E) Viral genes are transcribed before viral DNA replication occurs.
17. In the presence of a fixed concentration of a competitive inhibitor, which of the following would best characterize an enzyme-catalyzed reaction when the concentration of the substrate is increased?
- (A) The inhibition does not change.
  - (B) The inhibition decreases.
  - (C) The  $K_m$  increases.
  - (D) The maximal rate of reaction ( $V_{max}$ ) increases.
  - (E) The maximal rate of reaction ( $V_{max}$ ) decreases.

GO ON TO THE NEXT PAGE.

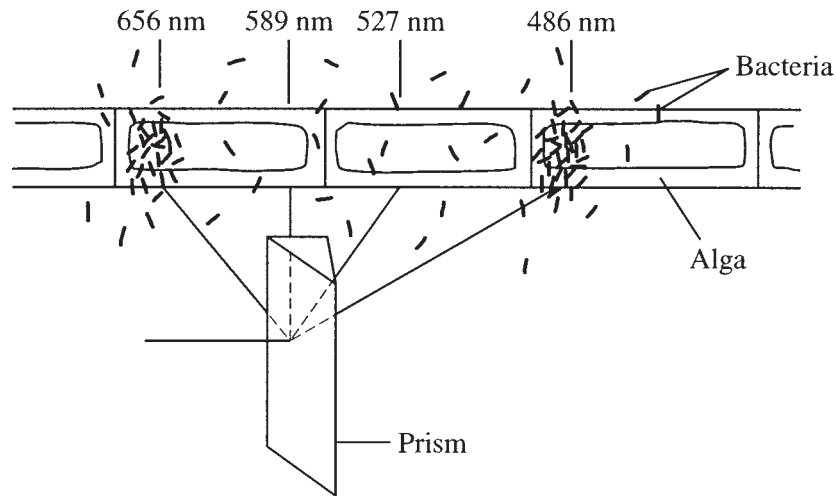

18. The filamentous alga *Cladophora* is illuminated with light dispersed by a prism. As shown in the diagram above, aerobic bacteria *Pseudomonas* included in the medium congregate where the alga is illuminated with light at 656 nanometers and at 486 nanometers. *Pseudomonas* do not congregate in this manner if the *Cladophora* is removed from the medium. Which of the following is the most likely explanation for the bacterial movement?
- (A) Bacteria have a phototropic response stimulated by light at 656 nm and 486 nm.
- (B) Starch made by photosynthesis is secreted from the alga in regions illuminated by light at 656 nm and at 486 nm.
- (C) O<sub>2</sub> evolved by photosynthesis in the regions illuminated by light at 656 nm and 486 nm attracts bacteria.
- (D) Alga and bacteria have a symbiotic relationship; the bacteria need O<sub>2</sub> supplied by the alga and the alga requires CO<sub>2</sub> supplied by the bacteria.
- (E) Bacteria are repelled by high CO<sub>2</sub> in regions illuminated by light at 589 nm and 527 nm.

- 
19. Biological oxidation of glucose resulting in which of the following metabolic end products would yield the largest number of ATP molecules?
- (A) CH<sub>3</sub>CHOHCOOH
- (B) CH<sub>3</sub>COCOOH
- (C) CO<sub>2</sub> + N<sub>2</sub> + H<sub>2</sub>O
- (D) CO<sub>2</sub> + H<sub>2</sub>S
- (E) CO<sub>2</sub> + H<sub>2</sub>O

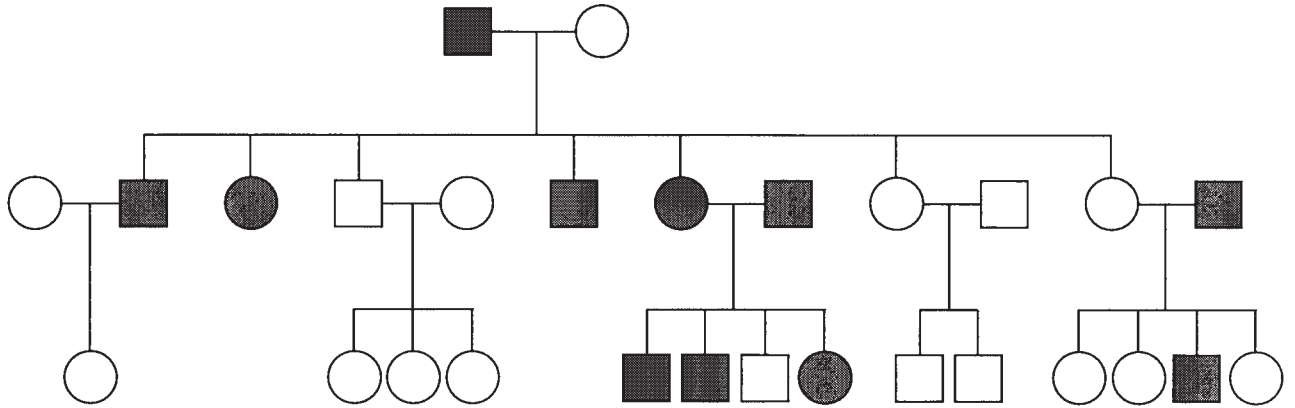

20. In the pedigree above, circles denote females, squares denote males, and shaded figures denote individuals expressing a specific trait. Which of the following is the most probable mode of inheritance of this trait?

- (A) Simple Mendelian dominant
- (B) Simple Mendelian recessive
- (C) Codominant relationship of a single pair of alleles
- (D) X-linked dominant transmission
- (E) Polygenic inheritance

21. The distribution of transmembrane proteins in the plane of a cell membrane can best be visualized by which of the following?

- (A) Thin-section electron microscopy
- (B) Freeze-fracture electron microscopy
- (C) Scanning electron microscopy
- (D) Ultraviolet spectroscopy
- (E) SDS-gel electrophoresis

23. All of the following occur during maturation of a proplastid into a chloroplast EXCEPT

- (A) an increase in size
- (B) an increase in the number of grana
- (C) the development of thylakoids
- (D) the bleaching of chlorophyll
- (E) the synthesis of pigments

22. Plasmodesmata most closely resemble which of the following structures in animal cells?

- (A) Desmosomes
- (B) Gap junctions
- (C) Basal laminae
- (D) Tight junctions
- (E) Ion channels

GO ON TO THE NEXT PAGE.

Unauthorized copying or reuse of  
any part of this test is illegal.



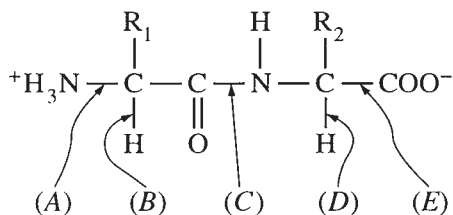

24. A peptidase hydrolyzes peptide bonds in small proteins. In the dipeptide shown above, which bond would be hydrolyzed?

- (A) A
- (B) B
- (C) C
- (D) D
- (E) E

25. All of the following cellular events involve actin filaments EXCEPT

- (A) amoeboid movement
- (B) cytoplasmic streaming
- (C) cytokinesis
- (D) contraction in smooth muscles
- (E) flagellar movement in bacteria

26. Eukaryotic and prokaryotic cells share all of the following features EXCEPT

- (A) ribosome-dependent protein synthesis
- (B) ATP synthesis linked to a proton gradient
- (C) a selectively permeable plasma membrane
- (D) a cytoskeleton of tubulin
- (E) a semiconservative replication of DNA

27. In *E. coli*, induction of the lactose operon occurs when allolactose binds to

- (A) galactosidase
- (B) *lac* mRNA
- (C) the operator
- (D) the promoter
- (E) the repressor

28. Synthesis and processing of eukaryotic messenger RNA include all of the following events EXCEPT

- (A) formation of a ribonucleoprotein complex
- (B) formation of a short region of RNA-DNA duplex
- (C) addition of polyuridine to the 3' end
- (D) addition of a methylguanosine to the 5' end
- (E) ligation of exons

GO ON TO THE NEXT PAGE.

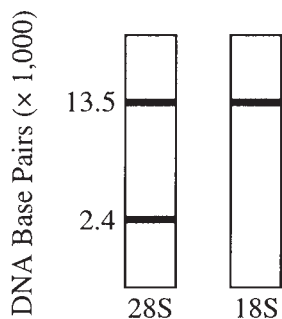

29. The autoradiograms above (after electrophoresis and Southern blotting) show human DNA digested with a specific restriction enzyme and probed with labeled rRNA. In the autoradiogram on the left, the probe was 28S rRNA; at the right, the probe was 18S rRNA. If the arrows in the following maps locate the recognition sites of the restriction enzyme, which map best explains the results shown above?

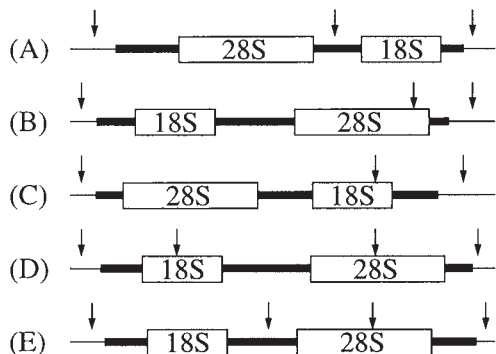

30. During which of the following stages of the cell cycle will a diploid cell contain twice the amount of DNA found in a gamete?

- (A) Prophase
- (B) Entire S phase
- (C) Entire  $G_1$  phase
- (D) Entire  $G_2$  phase
- (E) Metaphase

31. Catabolite repression in *E. coli* bacteria, involving the catabolite activator protein (CAP), is actually a type of positive regulation, because

- (A) cAMP-CAP helps RNA polymerase to initiate transcription
- (B) cAMP-CAP prevents RNA polymerase from initiating transcription
- (C) glucose binds to CAP and activates it
- (D) glucose binds to CAP and inactivates it
- (E) glucose stimulates the production of cAMP

32. The rate at which a DNA fragment moves in an electrophoretic gel is primarily a function of the fragment's

- (A) length
- (B) double helical structure
- (C) radioactivity
- (D) degree of methylation
- (E) adenine content

33. Mitochondria and chloroplasts carry out oxidative phosphorylation and photophosphorylation, respectively, by means of

- (A) conformational coupling
- (B) chemiosmotic coupling
- (C) high-energy intermediate coupling
- (D) photorespiration
- (E) sliding filaments

GO ON TO THE NEXT PAGE.

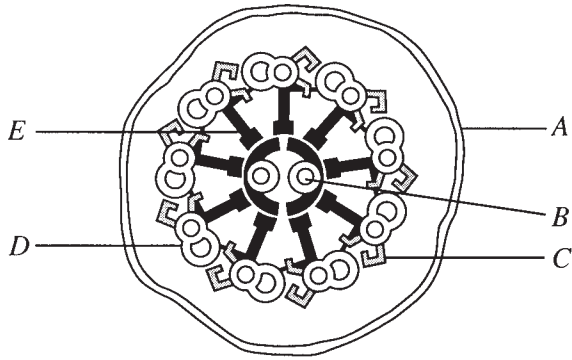

34. In the diagrammatic cross section of a cilium shown above, which elements contain dynein ATPase?
- (A) A  
(B) B  
(C) C  
(D) D  
(E) E
35. In mammals, which of the following are produced after rearrangement of DNA sequences in specific cells?
- (A) Hemoglobins  
(B) Actins  
(C) Antigens  
(D) Antibodies  
(E) Trypsins
36. At least 30 percent of human DNA exists as repeated multiples of relatively short sequences of nucleotides. Which of the following statements about this repetitive DNA is correct?
- (A) Much of the repetitive DNA is transcribed into messenger RNA.  
(B) Repetitive DNA is largely responsible for the production of enzymes and other protein molecules.  
(C) Most repeated sequences are associated with detectable phenotypes.  
(D) Highly repeated sequences rapidly reassociate in DNA hybridization studies.  
(E) Most of the repetitive DNA codes for transfer RNA.

37. Proteins associated with DNA in a eukaryotic chromosome serve all of the following functions EXCEPT
- (A) attachment to the plasma membrane  
(B) stabilization of chromosome structure  
(C) regulation of gene transcription  
(D) regulation of DNA replication  
(E) catalysis of deoxynucleoside triphosphate polymerization
38. In eukaryotes the large subunits of ribulose biphosphate carboxylase/oxygenase are coded for by the DNA and then synthesized (translated) in the
- (A) mitochondria  
(B) peroxisomes  
(C) vacuoles  
(D) nuclei  
(E) chloroplasts
39. Successful reproduction of a lytic virus requires that all of the following processes occur EXCEPT
- (A) incorporation of viral DNA into host cell DNA  
(B) translation of viral mRNA  
(C) binding of the virus to the host cell's surface  
(D) penetration of the viral genome into the host cell  
(E) replication of the viral genome

GO ON TO THE NEXT PAGE.

40. Cloned cDNA of beta-hemoglobin mRNA can direct the synthesis of a complete and correct polypeptide in the bacterium *E. coli*, whereas the corresponding cloned chromosomal gene cannot because
- bacterial polymerases cannot transcribe intervening sequences
  - intervening sequences contain codons that are not recognized by tRNA
  - bacteria lack the enzymes necessary for splicing eukaryotic mRNA precursors
  - intervening sequences contain hairpin loops that block ribosomal function
  - bacteria cannot process the protein precursor to its correct size
41. When transported out of the phloem, sucrose is converted to starch by which of the following organelles in root cells?
- Vacuoles
  - Lysosomes
  - Peroxisomes
  - Mitochondria
  - Plastids
42. In which of the following human male cells are there only chromosomes that are nonhomologous to each other?
- Hepatocytes
  - Erythroblasts
  - Leukocytes
  - Chondrocytes
  - Spermatozoa
43.  $C_4$  plants, by decreasing photorespiration and efficiently carrying out photosynthesis, can
- decrease stomatal openings and thereby reduce water loss
  - decrease stomatal openings and thereby reduce leaf temperature
  - increase stomatal openings and thereby increase water loss
  - increase stomatal openings and thereby increase leaf temperature
  - increase stomatal openings and thereby increase transpiration rates
44. Which of the following statements best characterizes a hydrostatic skeleton?
- Extensor and flexor muscles originate on the skeleton and insert on the body wall.
  - The skeleton is rigid and movement occurs by means of a system of joints.
  - Sets of circular and longitudinal muscles contract against an incompressible fluid.
  - The muscular/skeletal system permits straight-ahead movement; bending and turning do not occur.
  - In some aquatic animals, the skeleton is external to the body tissues and resists hydrostatic pressure.
45. A vitamin that has an important role in the formation of collagen fibers and the prevention of scurvy is
- thiamin
  - riboflavin
  - pyridoxine
  - ascorbic acid
  - tocopherol
46. The flagellate *Euglena* has all of the following cytological characteristics EXCEPT
- a contractile vacuole
  - a membrane-bound nucleus
  - paramylon granules
  - a cell wall external to the plasma membrane
  - an eyespot

GO ON TO THE NEXT PAGE.

47. Fluid is moved in the excretory tubules of flatworms by
- (A) ciliary activity in nephrostomes
  - (B) blood pressure in glomeruli
  - (C) ciliary activity in flame cells
  - (D) active transport across duct walls
  - (E) muscular contraction of nephridial walls
48. Countercurrent flow provides an efficient means of exchange between the
- (A) filaments of a fish gill and the surrounding water
  - (B) blood in the capillaries and the adjacent body cells
  - (C) alveoli of human lungs and the adjacent capillaries
  - (D) capillaries in the glomerulus and Bowman's capsule
  - (E) lumen of the small intestine and the capillaries within the villi
49. The greatest exchange of glucose and oxygen between vertebrate blood and body tissues occurs through the
- (A) arteries
  - (B) veins
  - (C) capillaries
  - (D) peritoneum
  - (E) glomeruli
50. Zinc is an important plant nutrient primarily because it is associated with
- (A) nucleic acids
  - (B) enzymes
  - (C) the active site of the chlorophyll molecule
  - (D) the primary structure of proteins
  - (E) ionic balance
51. Of the following, which appears first in the fossil record?
- (A) Insects
  - (B) Corals
  - (C) Octopi
  - (D) Amphioxii
  - (E) Lamprey eels
52. Blood fibrinogen is converted into fibrin during
- (A) CO<sub>2</sub> transport
  - (B) oxygen transport
  - (C) an immune response
  - (D) glucose regulation
  - (E) clot formation
53. All of the following are found in vertebrate smooth muscle EXCEPT
- (A) sarcomeres
  - (B) thin filaments
  - (C) thick filaments
  - (D) tropomyosin
  - (E) gap junctions
54. Which of the following statements best characterizes the embryo of a vertebrate as compared with the embryo of a protostomate invertebrate?
- (A) The anus forms at or near the blastopore.
  - (B) The mouth forms before the anus.
  - (C) The fate of cells is determined earlier.
  - (D) The embryo forms a solid blastula.
  - (E) The egg shows spiral cleavage.

GO ON TO THE NEXT PAGE.

55. All of the following are responses of the vertebrate egg to fusion with the male gamete EXCEPT the
- (A) completion of maturation (meiotic division)
  - (B) loss of the ability to undergo mitosis
  - (C) transient elevation of intracellular free calcium
  - (D) fusion of male and female pronuclei
  - (E) activation of the metabolic machinery
56. Which of the following is secreted principally by the corpus luteum of the human ovary?
- (A) Luteinizing hormone
  - (B) Follicle-stimulating hormone
  - (C) Testosterone
  - (D) Gonadotropin-releasing factor
  - (E) Progesterone
57. The fact that the tail muscle of an amphibian tadpole degenerates during metamorphosis, while the tadpole limb muscle differentiates and grows, best supports which of the following statements?
- (A) The effect of a hormone can be predicted if it is known that a tissue has receptors for that hormone.
  - (B) Similar tissues can respond to a hormone in different ways.
  - (C) Only the tail muscle has receptors for thyroxine.
  - (D) Only the limb muscle has receptors for thyroxine.
  - (E) A hormonal response is a function of the molecular structure of the hormone.
58. In mammals, metabolic rate varies with (body mass)<sup>0.75</sup>. Which of the following can be correctly inferred from this relationship?
- (A) Mass-specific metabolic rate decreases as body mass increases.
  - (B) A 20-gram mouse consumes more calories than a 3-kilogram woodchuck.
  - (C) Metabolic rate will increase with decreasing environmental temperatures.
  - (D) Metabolic rate increases more rapidly than body mass.
  - (E) Food intake is unrelated to body size.
59. Which of the following adaptations appeared for the first time in the common ancestor of the mammals, birds, and modern reptiles?
- (A) Membranous lungs
  - (B) Internal nostrils
  - (C) Tetrapod limbs
  - (D) Amniotic eggs
  - (E) Hinged jaws
60. In summer, the oxygen consumptions of a tree squirrel and of a lobster were first measured after 1 hour at 20°C and then after 1 hour at 10°C. Which of the following best describes the respective oxygen consumptions as the temperature changed from 20°C to 10°C ?
- | <u>Tree Squirrel</u> | <u>Lobster</u>    |
|----------------------|-------------------|
| (A) Increased        | Remained constant |
| (B) Decreased        | Remained constant |
| (C) Decreased        | Increased         |
| (D) Increased        | Increased         |
| (E) Increased        | Decreased         |

GO ON TO THE NEXT PAGE.

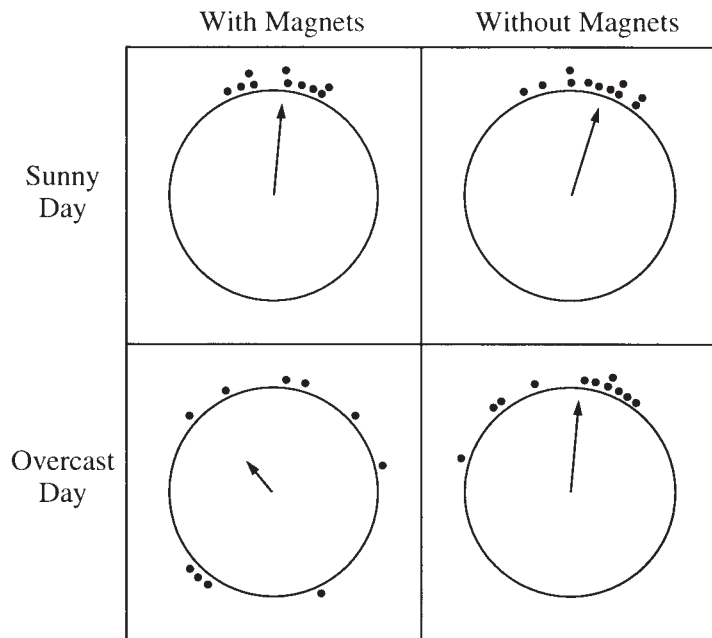

61. In the diagram above, the center of each circle represents the location at which homing pigeons were released. The top of each circle is the homeward direction, each dot represents the direction taken by one bird, and the arrows represent the statistical average of the chosen directions. The birds in the left-hand circles were equipped with magnets that prevented them from detecting the Earth's magnetic field. This experiment demonstrated that homing pigeons

- (A) can navigate only on sunny days
- (B) can use either the Sun or the Earth's magnetic field as navigational aids
- (C) use only the Sun as a compass for navigation
- (D) use only the Earth's magnetic field for navigation
- (E) lose navigational ability when magnets are attached to them

62. Branch roots of the primary root of a flowering plant are initiated in the

- (A) cortex
- (B) pericycle
- (C) epidermis
- (D) endodermis
- (E) vascular tissue

63. All of the following are true of mycorrhizae EXCEPT:

- (A) They permit plants to survive in phosphorus-poor environments.
- (B) They increase the absorptive surface of plants.
- (C) Their growth depends on carbohydrates from the plant.
- (D) They form nitrogen-fixing nodules on roots.
- (E) They may transfer nutrients from one plant to another.

64. Approximately what percentage of water that is absorbed by a corn plant is lost by transpiration?
- (A) 5%  
 (B) 10%  
 (C) 25%  
 (D) 50%  
 (E) 90%
65. Which of the following is a major reason for the ascent of water in trees?
- (A) The forces of attraction between water molecules  
 (B) The structure of cells in the phloem  
 (C) A gradient of osmotic pressure in the tracheids  
 (D) A gradient of osmotic pressure in the xylem parenchyma cells  
 (E) A metabolic pump in the roots
66. In the phloem of some plants, companion cells probably provide metabolic energy for movement of substances into and out of the sieve tubes. Which of the following is most consistent with this statement?
- (A) There are high rates of translocation at low temperatures.  
 (B) There are low rates of respiration in companion cells.  
 (C) There are no plasmodesmata between companion cells and sieve-tube members.  
 (D) There is an abundance of rRNA in the sieve-tube members.  
 (E) There is an abundance of mitochondria in the companion cells.
67. Which of the following algae evolved cells comparable to sieve tubes in vascular plants?
- (A) *Fucus*, the rockweed  
 (B) *Macrocystis*, a giant kelp  
 (C) *Ulva*, sea lettuce  
 (D) *Ceratium*, a dinoflagellate  
 (E) *Porolithon*, a coralline red alga
68. Which of the following statements is correct for many plants concerning the activity of phytochrome?
- (A) It transports electrons in photosynthesis.  
 (B) It mediates the flowering response to day length.  
 (C) It produces stem curvature by migrating selectively to one side of the stem.  
 (D) It stimulates dedifferentiation of extra-wide xylem vessels in ring-porous wood.  
 (E) It stimulates and synchronizes fruit abscission.
69. Which of the following plant hormones hastens apple ripening?
- (A) Auxin  
 (B) Gibberellin  
 (C) Abscisic acid  
 (D) Cytokinin  
 (E) Ethylene
70. Garden bean cotyledons have all of the following characteristics EXCEPT:
- (A) They are the energy source for the germinating plant.  
 (B) They dry and drop off while the plant is a seedling.  
 (C) They constitute the bulk of the seed.  
 (D) They have apical meristems.  
 (E) There are two per seed.
71. Which of the following statements is most compatible with the "source-sink" concept of sugar transport in the phloem?
- (A) Sugars are loaded at the sink.  
 (B) Sugars move from the sink to the source in the phloem.  
 (C) Sugars are unloaded at the source.  
 (D) Developing young leaves are sinks and fully developed leaves are sources.  
 (E) Transport is always unidirectional in the phloem.

GO ON TO THE NEXT PAGE.



72. In pollen of flowering plants, two sperm are formed by
- (A) the first meiotic division
  - (B) the second meiotic division
  - (C) mitosis of a haploid cell
  - (D) mitosis of a diploid cell
  - (E) fusion of gametes
73. Transfer of the sperm to the egg in ferns and mosses occurs via
- (A) a pollen tube
  - (B) a haustorium
  - (C) a dwarf male gametophyte
  - (D) a free-water film
  - (E) wind
74. Under aerobic conditions, some blue-green bacteria (cyanobacteria) reduce atmospheric nitrogen in
- (A) akinetes
  - (B) hormogonia
  - (C) endospores
  - (D) exospores
  - (E) heterocysts
75. Red algae and brown algae are able to live at greater depths in the ocean than other algae because
- (A) they are heterotrophic
  - (B) they have chlorophyll *b*
  - (C) they can withstand cold temperatures
  - (D) their accessory pigments absorb red light
  - (E) their accessory pigments absorb blue and green light
76. The yeast *Saccharomyces cerevisiae* is classified as belonging to which of the following groups?
- (A) Eubacteria
  - (B) Oomycota
  - (C) Zygomycota
  - (D) Ascomycota
  - (E) Basidiomycota
77. During development of the embryo sac of most flowering plants, the central cell is binucleate and will eventually form the nutrient endosperm of the seed. Following fertilization, what is the ploidy level of the endosperm?
- (A) Haploid
  - (B) Diploid
  - (C) Triploid
  - (D) Tetraploid
  - (E) Pentaploid

GO ON TO THE NEXT PAGE.

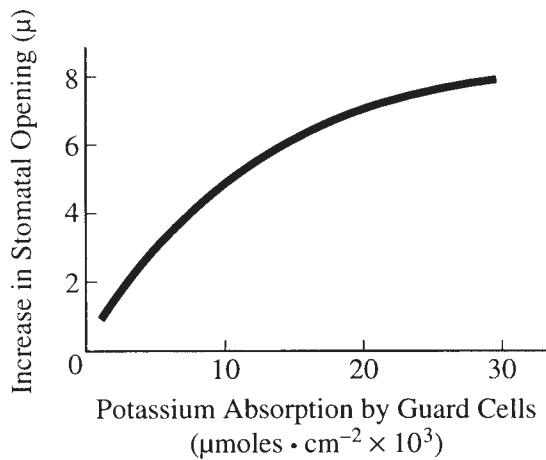

78. A study concerning the opening of stomata produced results that are shown in the graph above. From this graph, which of the following can correctly be concluded?
- (A) Potassium absorption, rather than osmotic regulation by glucose, is responsible for stomatal opening.
  - (B) Potassium is actively transported into guard cells during the day and then leaks out to reach equilibrium at night.
  - (C) Potassium intake into the guard cell is directly proportional to the amount of time that a plant is exposed to light.
  - (D) An increase in potassium uptake by guard cells is accompanied by stomatal opening.
  - (E) An increase in potassium absorption to more than 30  $\mu\text{moles}$  would lead to rupture of the membrane and closing of the stomata.

79. With respect to human height, the production of short individuals by two average-sized parents is best explained by
- (A) mutation
  - (B) sex linkage
  - (C) polygenic inheritance
  - (D) epistasis
  - (E) discontinuous variation
80. If the axis of the Earth were not tilted with respect to its plane of orbit, the Earth would exhibit
- (A) the same annual seasons as now occur
  - (B) longer winters and shorter summers
  - (C) longer springs and shorter falls
  - (D) an absence of seasons
  - (E) an absence of latitudinal gradients
81. At which of the following trophic levels is the greatest amount of free energy available?
- (A) Producers
  - (B) Decomposers
  - (C) Herbivores
  - (D) Secondary consumers
  - (E) Tertiary consumers

GO ON TO THE NEXT PAGE.

82. A balanced polymorphism may be maintained by all of the following EXCEPT
- (A) natural selection
  - (B) directional selection
  - (C) heterozygote advantage
  - (D) use of multiple niches
  - (E) frequency-dependent selection
83. A severe winter storm kills many chickadees. An investigation comparing the body size of dead birds with that of survivors reveals that the dead birds included mainly the largest and smallest members of the population. This winter storm exemplifies
- (A) kin selection
  - (B) stabilizing selection
  - (C) directional selection
  - (D) balancing selection
  - (E) disruptive selection
84. All of the following may be true of a population with a stable age distribution EXCEPT:
- (A) The number of organisms is changing at a constant rate.
  - (B) Age-specific birth and death rates are not changing over time.
  - (C) Population size is increasing.
  - (D) The proportions of organisms in each age class are changing.
  - (E) Population size is decreasing.
85. Larger islands may have greater species diversity than smaller islands because larger islands
- (A) are in the tropics
  - (B) are farther from continents than smaller islands are
  - (C) have more habitats than smaller islands do
  - (D) have greater genetic drift than smaller islands do
  - (E) have no reproductive isolation among their populations
86. Two of the premises that form the basis of Darwin's concept of natural selection are
- (A) ecotype and race
  - (B) heritability and fitness
  - (C) uniformitarianism and catastrophism
  - (D) geographic and reproductive isolation
  - (E) dominance and recessiveness

GO ON TO THE NEXT PAGE.

87. Five similar populations of a herbaceous annual plant are monitored for three years; then, the numbers of individuals in populations I-IV are increased by an experimenter. Subsequent changes in the sizes of all the populations are shown in the graph below.

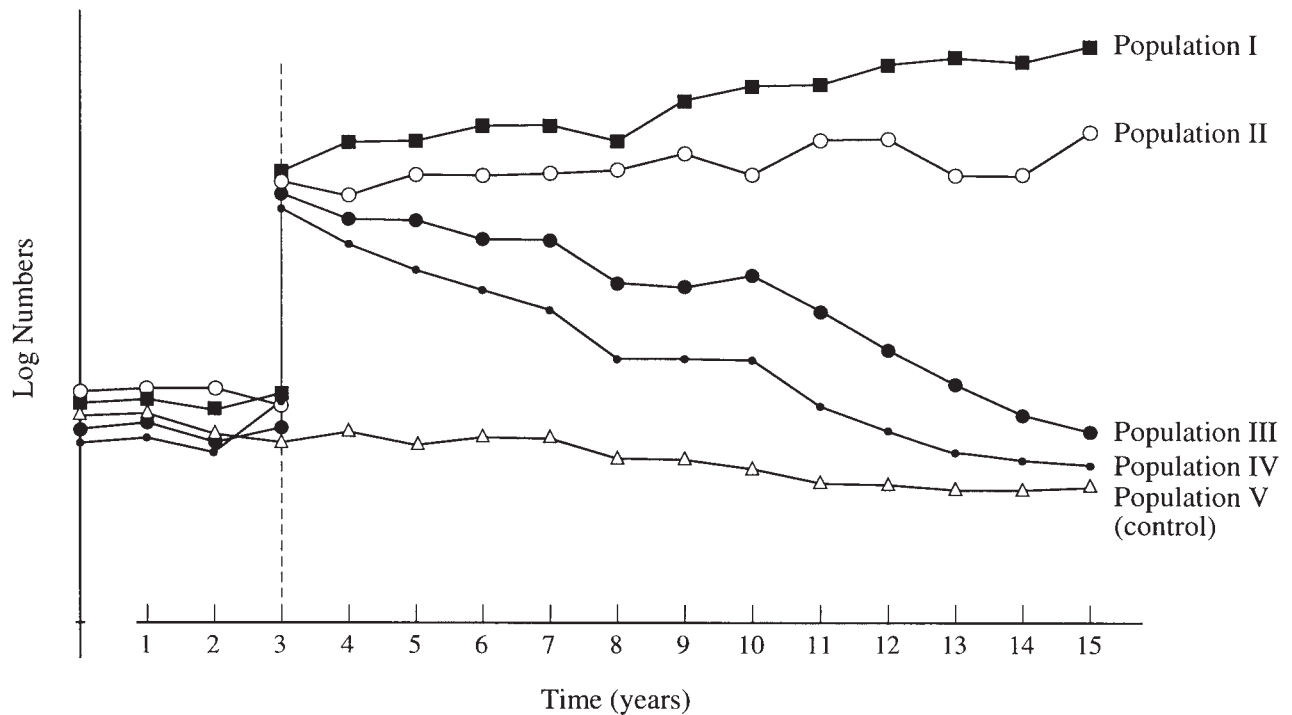

If size distributions of individuals do not vary among these populations, which of the following relationships best illustrates the occurrence of population regulation?

- (A) Populations I and II compared with population V  
 (B) Populations I and II compared with populations III and IV  
 (C) Populations III and IV compared with population V  
 (D) Population I compared with population II  
 (E) Population III compared with population IV
- 
88. In an ecosystem, fixed carbon has accumulated in the form of organic matter derived from dead plants and animals. Which of the following is the best explanation for this observation?
- (A) Decomposer activity has been low.  
 (B) Producers have been utilizing sunlight inadequately.  
 (C) There have been insufficient numbers of secondary consumers.  
 (D) Primary consumers have been absent from the ecosystem.  
 (E) Nitrogen has been cycled, but carbon has not.
89. Which of the following is a density-independent factor that could limit a population of high-altitude butterflies?
- (A) A late spring snowstorm  
 (B) Predation  
 (C) Scarcity of oviposition sites  
 (D) Competition for nectar  
 (E) Parasitism

GO ON TO THE NEXT PAGE.

90. One summer the moose population on Isle Royale was unusually high, and park naturalists noticed signs of malnutrition among the adults. The wolf population was fairly low, near 20. That winter, for the first time in many years, a substantial number of seemingly healthy adult moose as well as calves and crippled animals were killed and eaten by wolves. This description is part of a general situation in which the wolf and moose populations
- are maintained in a stable equilibrium, from year to year
  - are simultaneously becoming extinct
  - fluctuate out of phase with each other
  - fluctuate independently of each other
  - fluctuate in phase with each other
91. A prime factor promoting the adaptive radiation of Darwin's finches on the Galápagos Islands was the
- variety of available and suitable habitats
  - high predation pressure
  - genetic uniformity of the original invading population of birds
  - presence of true warblers and true woodpeckers on the islands
  - unusually high mutation rate that promoted new variants
92. All of the following are adaptations that permit the camel to be active by day in the desert EXCEPT
- thick fur
  - hyperthermia
  - elongated nasal cavity
  - water storage in the hump
  - large size
93. Among the ecological relationships below, which is most different from the other four?
- Fungal mycelia around algal cells in a lichen
  - Algal cells embedded in coral tissues
  - Salmonella* in the human gut
  - Cellulose-digesting protozoa in a termite gut
  - Nitrogen-fixing bacteria in the nodules of a bean plant
94. Niches of two coexisting species of pond snail of the same genus are likely to be similar, but not identical, because of which of the following?
- Closely related species use similar resources.
  - Competitive interactions exist between these species.
  - Unlimited resources are available.
- I only
  - II only
  - III only
  - I and II
  - I and III
95. In which of the following habitats would one expect to find the highest diversity of vascular plants?
- Salt marsh
  - Mine tailings
  - Spruce-fir forest
  - Small island
  - Prairie-forest ecotone
96. In deep-sea hydrothermal vents near the Galápagos Islands, bacteria obtain energy by oxidizing hydrogen sulfide released from the vents. Giant tube worms, which lack mouths and digestive systems, harbor the bacteria in their tissues and use them as a source of organic molecules. Clams obtain energy by filtering bacteria directly from the water, and numerous crabs and octopi feed on the clams. In this unique ecosystem, the bacteria are playing the role of
- primary producers
  - primary consumers
  - secondary consumers
  - tertiary consumers
  - decomposers

GO ON TO THE NEXT PAGE.

97. Which of the following would be considered to be a natural population in a pond?
- (A) All the individuals of the genus *Rana*
  - (B) All the animals
  - (C) All the individuals of the species *Rana pipiens*
  - (D) All the organisms of any two species affecting each other ecologically
  - (E) All the adults of any one species
98. The massive adaptive radiation of insects over the world is most likely related to the
- (A) worldwide increase in species diversity in the Cambrian period
  - (B) evolution of the land flora by the middle of the Paleozoic era
  - (C) massive extinction at the end of the Mesozoic era
  - (D) human alteration of the environment in the Pleistocene epoch
  - (E) environmental stability of the seas over all of geological time
99. One group of ecologists has suggested that producers are limited by competition for resources, primary consumers (herbivores) are limited by predation, and secondary consumers (carnivores) are limited by food. If this were true, at which of the following trophic levels would one expect to find substantial evidence for competitive exclusion?
- (A) Producer only
  - (B) Herbivore only
  - (C) Carnivore only
  - (D) Producer and carnivore
  - (E) Herbivore and carnivore
100. Which of the following statements is most likely correct concerning the Hardy-Weinberg equilibrium in natural populations?
- (A) It occurs infrequently in small populations from natural communities.
  - (B) It occurs in founding populations, but not in established populations.
  - (C) It occurs in populations from late successional communities, but not from early successional communities.
  - (D) It occurs on small islands, but not on large islands.
  - (E) It occurs in species undergoing stabilizing selection, but not in species undergoing balancing selection.
101. Under some circumstances a population can split into two or more species without the existence of geographic barriers. All of the following genetically determined behaviors could provide conditions leading to speciation EXCEPT
- (A) selection of a specific host fruit for completion of the life cycle by a fruit fly
  - (B) association of courtship with a particular habitat type in a sparrow
  - (C) choice by a butterfly of the time of day to breed
  - (D) release of gametes into the ocean by a marine invertebrate in response to a chemical in the water
  - (E) selection of prey types by a wide-ranging hawk

GO ON TO THE NEXT PAGE.

102. If the alleles  $A$  and  $a$  conform to Hardy-Weinberg expectations, and if the frequency of  $a$  is 0.3, which of the following is the most common genotype in the population?
- $A$
  - $a$
  - $AA$
  - $Aa$
  - $aa$
103. The theory of punctuated equilibrium argues that
- speciation and morphological divergence are weakly associated
  - selective forces act throughout a species' lifetime
  - major morphological changes are separated by long periods of morphological stasis
  - morphological changes occur through selection on polygenic variants
  - speciation rates are not related to evolutionary rates
104. Which of the following is true of a selectively neutral gene that is a mutant allele at a locus?
- Its effects on fitness are different from those of the more frequent allele that leads to a normal phenotype.
  - It reaches high frequencies because of the state of balanced polymorphism.
  - It confers neither reproductive advantage nor disadvantage on the individual.
  - Its expression is masked by the normal allele.
  - It improves the fitness of the individual in the heterozygous state.
105. Which of the following is a postzygotic isolating mechanism in speciation?
- Isolation by hybrid sterility
  - Isolation by habitat
  - Seasonal isolation
  - Behavioral isolation
  - Geographic isolation
106. The phenomenon of genetic drift is most likely to occur in populations that
- are large and panmictic
  - are undergoing gene flow
  - are allopatric
  - are small and inbred
  - have great reproductive potential
107. Two populations of land snails have been effectively isolated from each other for a long period. According to the biological species concept, which of the following would demonstrate that the two populations have become separate species?
- The two populations differ in at least five morphological traits.
  - The two populations behave differently when subjected to the same dose of pesticides.
  - Sterile hybrids are produced when members of the two populations are experimentally mated.
  - DNA nucleotide sequences are different between the two populations.
  - The two populations have different electrophoretic patterns of proteins.
108. The resemblance of body structure and mode of life of some species of Australian marsupials to certain species of placental mammals is an example of
- convergent evolution
  - punctuated equilibrium
  - genetic drift
  - sequential evolution
  - polymorphism
109. Which of the following plant groups is now extinct?
- Tree ferns
  - Dinoflagellates
  - Seed ferns
  - Horsetails
  - Strangler figs

GO ON TO THE NEXT PAGE.

110. If one compares the primary structure of the protein cytochrome *c* in organisms that are separated in evolutionary time, e.g., humans and yeast, one discovers that
- (A) hydrophilic amino acids are usually substituted for hydrophobic amino acids
  - (B) the overall tertiary structure of the molecules is quite different
  - (C) the proteins have evolved different functions
  - (D) considerable sequence similarity exists between the two proteins
  - (E) no differences exist in the primary structures
111. Which of the following genotypes would produce the greatest variety of gametes if the alleles assorted independently?
- (A) *aa BB Cc Dd*
  - (B) *aa bb CC DD*
  - (C) *Aa Bb CC Dd*
  - (D) *AA BB CC DD*
  - (E) *AA bb cc Dd*
112. Which of the following is most likely to reduce competition in sympatric, closely related species?
- (A) Darwinian fitness
  - (B) Kin selection
  - (C) Niche overlap
  - (D) Stabilizing selection
  - (E) Character displacement
113. It is now thought that the atmosphere of the primitive Earth was composed largely of carbon dioxide, nitrogen, and water vapor. The composition of certain iron-containing minerals suggests that the carbon dioxide began to be replaced by oxygen about 2 billion years ago. Which of the following is the best explanation for the change in atmospheric composition?
- (A) Ozone produced in the upper atmosphere by ultraviolet light broke down to oxygen.
  - (B) Minerals such as iron oxide released oxygen into the atmosphere.
  - (C) Oxygen was present in volcanic gases and slowly accumulated with time.
  - (D) Water was broken down into oxygen and hydrogen by lightning discharges.
  - (E) Photosynthesis was established in primitive bacteria.
114. The amino acids in the amino acid sequences of the polypeptide chains of human proteins differ from those of chimpanzees by approximately what percentage?
- (A) 90%
  - (B) 50%
  - (C) 30%
  - (D) 15%
  - (E) 1%

GO ON TO THE NEXT PAGE.



115. An important evolutionary benefit of sexual reproduction is that
- (A) it provides a mechanism for genetic recombination
  - (B) it requires a lower level of resource investment than asexual reproduction does
  - (C) the offspring will resemble their parents genetically
  - (D) the offspring will probably not mate with parents or siblings
  - (E) the reproductive success rates are less variable than for asexual reproduction
116. A biome with dry and rainy seasons, trees in patches, and ground cover of tropical bunchgrass is called a
- (A) taiga
  - (B) prairie
  - (C) savanna
  - (D) chaparral
  - (E) tundra
117. The unit of life in which biological evolution actually occurs is usually considered to be the
- (A) adaptive trait of an individual
  - (B) whole organism
  - (C) population
  - (D) community
  - (E) ecosystem
118. It has been proposed that mitochondria and chloroplasts evolved from certain bacteria that existed as endosymbiotic organisms in early cells. Which of the following would best support this hypothesis?
- (A) Both organelles contain DNA molecules.
  - (B) Both organelles have microtubules.
  - (C) Both organelles lack mRNA.
  - (D) Mitochondria, but not chloroplasts, are surrounded by a double membrane.
  - (E) Chloroplasts, but not mitochondria, are able to synthesize protein.

GO ON TO THE NEXT PAGE.

Directions: Each group of questions below consists of five lettered headings followed by a list of numbered words, phrases, or sentences. For each numbered word, phrase or sentence, select the one heading that is most closely related to it and fill in completely the corresponding space on the answer sheet. One heading may be used once, more than once, or not at all in each group.

Questions 119-121

- (A) Covalent bond
- (B) Ionic bond
- (C) Hydrogen bond
- (D) van der Waals interaction
- (E) Hydrophobic interaction

- 119. Binding of a magnesium ion to ATP
- 120. Polymerization of nucleotides to yield RNA
- 121. Association of nonpolar groups in an aqueous solution

Questions 122-124

- (A) Cervix
- (B) Ovary
- (C) Fallopian tube (oviduct)
- (D) Uterus
- (E) Vagina

- 122. Contains cilia
- 123. Normal site of implantation of early embryo (blastocyst) in humans
- 124. Usual site of fertilization in humans

Question 125-127

- (A) Chordata
- (B) Mollusca
- (C) Echinodermata
- (D) Annelida
- (E) Arthropoda

- 125. Calcareous shell secreted by mantle
- 126. Paired excretory organs in most body segments
- 127. Respiration by tracheae, gills, or book lungs

Questions 128-129

- (A) hnRNA
- (B) mRNA
- (C) tRNA
- (D) rRNA
- (E) DNA

- 128. Carries an anticodon and a specific amino acid to a growing polypeptide chain
- 129. Is produced and packaged with proteins in the nucleolus

GO ON TO THE NEXT PAGE.

Questions 130-131

- (A) Iron
- (B) Boron
- (C) Magnesium
- (D) Copper
- (E) Zinc

130. Part of a heme prosthetic group
131. Bound in the porphyrin ring of chlorophyll *a*

Questions 132- 134

- (A) Plants on rock that was exposed by a receding glacier
- (B) Invertebrates and algae in desert streams
- (C) Field mice in an abandoned agricultural field
- (D) Plant species in a Mediterranean shrub community
- (E) Shade-tolerant trees in a tropical forest

132. Succession results from disturbance by fire.
133. The pattern of gap formation may influence species diversity.
134. Primary succession is occurring.

Questions 135-137

- (A) Reciprocal translocation
- (B) Duplication
- (C) Inversion
- (D) Replication
- (E) Deletion

135. Reverse in the sequence of a section of a chromosome relative to the normal chromosome
136. Interchange in position of segments of nonhomologous chromosomes
137. Presence of an extra segment of chromosome

Questions 138-141 refer to the development of some life history stages in a fern.

- (A) Gametophyte
- (B) Sporophyte
- (C) Sperm
- (D) Spore
- (E) Zygote

138. Develops from the haploid tissues of an antheridium
139. Results from meiotic divisions in the sporangia
140. Multicellular plant resulting from the mitotic divisions of a diploid cell
141. Multicellular plant resulting from the mitotic divisions of a haploid cell

Questions 142-143

- (A) Altruism
- (B) Cooperation
- (C) Nepotism
- (D) Reciprocity
- (E) Spite

142. Behavior by an individual that confers evolutionary benefits to a recipient at no evolutionary cost to the donor because the recipient delivers benefits to the donor at some later time
143. Behavior by an individual that increases the fitness of the recipient, but that lowers the fitness of the donor

Questions 144-145

- (A) Xylem tracheid
- (B) Epidermis
- (C) Endodermis
- (D) Spongy mesophyll
- (E) Palisade mesophyll

144. Considered dead when fully mature
145. Has the most numerous chloroplasts

**Directions:** Each group of questions below concerns a laboratory or an experimental situation. In each case, first study the description of the situation. Then choose the one best answer to each question and fill in completely the corresponding space on the answer sheet.

Questions 146-149

The Norway rat (*Rattus norvegicus*), a widespread pest, was controlled for about a decade by the anticoagulant warfarin. This chemical substance, placed in food pellets, is absorbed by the intestinal tract and inhibits the clotting of blood. After a population decline for about 10 years, rat populations increased and stabilized. In one European population, as illustrated in the graph below, the percentage of rats resistant to warfarin has remained fairly stable over a number of years.

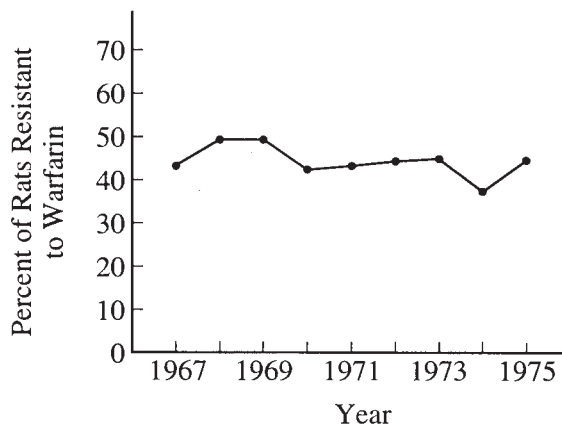

Resistance to warfarin is governed by a dominant autosomal gene, *R*. More than 15 percent of the resistant animals are heterozygous at this locus (*Rr*). The table below indicates the response to warfarin and relative reproductive fitness of individuals that are homozygous or heterozygous for the dominant gene (*R*). The *RR* individuals have a 20-fold increase in vitamin K requirement over *rr* individuals.

RELATIVE FITNESS* AT THE <i>R</i> LOCUS IN THE NORWAY RAT IN THE PRESENCE OF WARFARIN			
	<i>rr</i>	<i>Rr</i>	<i>RR</i>
Response to warfarin	Susceptible	Resistant	Resistant
Vitamin K dependence	No	Intermediate	Yes
Relative fitness	0.68	1.00	0.37

\*Fitness is a measure of the reproductive success of a particular genotype. The highest fitness is 1.00.

GO ON TO THE NEXT PAGE.

Unauthorized copying or reuse of  
any part of this test is illegal.

146. There is a substantial number of heterozygotes in the population. Which of the following is the best explanation of this observation?
- (A) Heterozygotes ( $Rr$ ) have a selective advantage over both homozygotes ( $RR$  and  $rr$ ).
  - (B) The gene for susceptibility ( $r$ ) is increasing rapidly each generation.
  - (C) The gene for susceptibility ( $r$ ) is being lost by chance each generation.
  - (D) Dominant homozygotes ( $RR$ ) enjoy a reproductive advantage over heterozygotes.
  - (E) Dominant homozygotes ( $RR$ ) produce more offspring each generation than either heterozygotes ( $Rr$ ) or recessive homozygotes ( $rr$ ).
147. In a population where warfarin is no longer applied, the expectation is that the
- (A) dominant gene ( $R$ ) will supplant the recessive gene ( $r$ ) in the population
  - (B) heterozygotes ( $Rr$ ) will have a reproductive advantage over both homozygotes ( $RR$  and  $rr$ )
  - (C) frequency of the dominant gene ( $R$ ) will decline
  - (D) frequency of recessive individuals will gradually decline
  - (E) frequency of the recessive gene ( $r$ ) will decline
148. The strong dependence of  $RR$  individuals on large quantities of vitamin K probably is responsible for
- (A) their lowered fitness
  - (B) their susceptibility to warfarin
  - (C) their superiority to heterozygotes ( $Rr$ )
  - (D) their increasing numbers in the population each generation
  - (E) the persistent decline of recessive homozygotes ( $rr$ ) in the population
149. Which of the following is most likely correct concerning the gene for resistance to warfarin?
- (A) It is a wild-type gene induced to mutate by the direct action of warfarin.
  - (B) It is a mutation subsequently favored by natural selection.
  - (C) It is increased in frequency by virtue of its dominant status.
  - (D) It is carried by a bacterial plasmid vector.
  - (E) It is a cytoplasmic gene transmitted by maternal inheritance.

GO ON TO THE NEXT PAGE.

Questions 150-153

Some individuals suffer from an autosomal recessive disorder known as “alpha<sub>1</sub>-antitrypsin deficiency.” The recessive homozygote for this disorder lacks the enzyme that ordinarily degrades trypsin. The genotype of the recessive disorder may be designated as *aa*. Normal individuals are either homozygous dominant (*AA*) or heterozygous carriers (*Aa*).

Enzymatic tests and colorimetric analysis reveal that a given individual possesses one of three distinct levels of alpha<sub>1</sub>-antitrypsin enzyme activity. The data below show the levels of trypsin inhibited per milliliter of serum (which contains the antitrypsin enzyme) in three different groups.

Group I: The general population

Group II: Several families in which some members have alpha<sub>1</sub>-antitrypsin deficiency

Group III: Patients with alpha<sub>1</sub>-antitrypsin deficiency

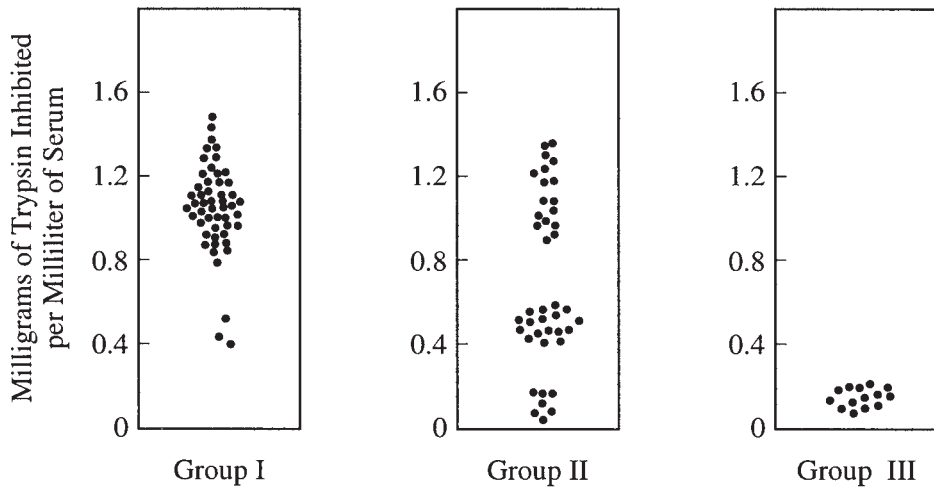

GO ON TO THE NEXT PAGE.

150. When the serum of an adult woman was tested colorimetrically, a level of 0.5 milligram of trypsin inhibited per milliliter of serum was found. This can be interpreted as indicating which of the following?
- (A) She is homozygous dominant.
  - (B) She is an asymptomatic heterozygous carrier.
  - (C) She will exhibit alpha<sub>1</sub>-antitrypsin deficiency.
  - (D) She will always transmit the abnormal recessive gene to her offspring.
  - (E) Her mother was most likely homozygous dominant.
151. If an offspring displays alpha<sub>1</sub>-antitrypsin deficiency, then it can be reasonably predicted that the phenotypically normal father would have a value for trypsin inhibition of
- (A)  $0.24 \text{ mg} \cdot \text{mL}^{-1}$
  - (B)  $0.50 \text{ mg} \cdot \text{mL}^{-1}$
  - (C)  $1.20 \text{ mg} \cdot \text{mL}^{-1}$
  - (D)  $1.60 \text{ mg} \cdot \text{mL}^{-1}$
  - (E)  $2.00 \text{ mg} \cdot \text{mL}^{-1}$
152. The possible genotypes of a person possessing a 0.2-milligram level of trypsin inhibited per milliliter of serum include
- (A) *AA* only
  - (B) *Aa* only
  - (C) *aa* only
  - (D) *AA* and *Aa*
  - (E) *Aa* and *aa*
153. The distribution of values in the general population can be interpreted to indicate that
- (A) heterozygous individuals (*Aa*) fail to reproduce
  - (B) affected offspring (*aa*) are derived largely from matings of two recessive parents (*aa* × *aa*)
  - (C) the recessive gene (*a*) is lethal at birth
  - (D) the recessive gene (*a*) is harbored mostly in heterozygous individuals
  - (E) the mutation process from *A* to *a* will lead to a decrease in the number of recessive genes

GO ON TO THE NEXT PAGE.

Questions 154-156

In replicated experiments, plots are planted with flax seeds in densities of 60, 1,440, and 3,600 per square meter, respectively. The factors of soil, water, and light are similar for each plot. Dry weights of the mature plants are obtained.

DISTRIBUTION OF DRY WEIGHTS OF INDIVIDUALS IN POPULATIONS OF FLAX PLANTS SOWN AT DIFFERENT DENSITIES

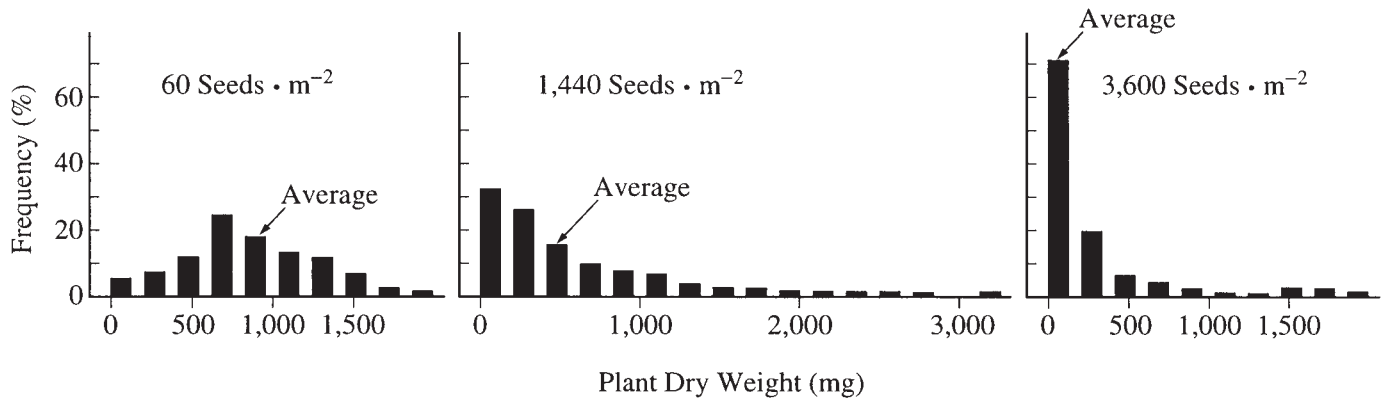

GO ON TO THE NEXT PAGE.

Unauthorized copying or reuse of  
any part of this test is illegal.



154. The experiments are most likely performed to test for
- (A) interspecific competition
  - (B) intraspecific competition
  - (C) competitive exclusion
  - (D) founder effect
  - (E) genetic drift
155. Increased densities in this experiment produce which of the following results in plants?
- (A) Etiolated leaves and stems
  - (B) Reduced individual biomass
  - (C) Normally distributed weights
  - (D) Reduced genetic variability
  - (E) Random expression of some traits
156. The experiment demonstrates that, while the total eventual harvest of biomass is not changed by crowding, individual plants show the effects of
- (A) resource replenishment at lower densities
  - (B) resource depletion at higher densities
  - (C) allelopathy at lower densities
  - (D) early maturation at lower densities
  - (E) inbreeding at lower densities

GO ON TO THE NEXT PAGE.

Questions 157-160

Birds were placed in a small room maintained at a constant temperature of 20°C and were provided with food. Lights were turned on at 0800 hours and were turned off at 2000 hours. Three experiments were conducted as follows.

In experiment 1, after three days of the light/dark cycle, the birds were placed in constant darkness and their activity cycles were recorded.

In experiment 2, after three days of the light/dark cycle, the birds were kept in the dark for another 12 hours. The lights were turned on at 2000 hours and turned off at 0800 hours for a number of days and the birds' activity cycles were recorded.

In experiment 3, after three days of the light/dark cycle, the birds' pineal glands were removed. The birds were returned to constant darkness and their activity cycles were recorded. These experiments are illustrated in the following figures.

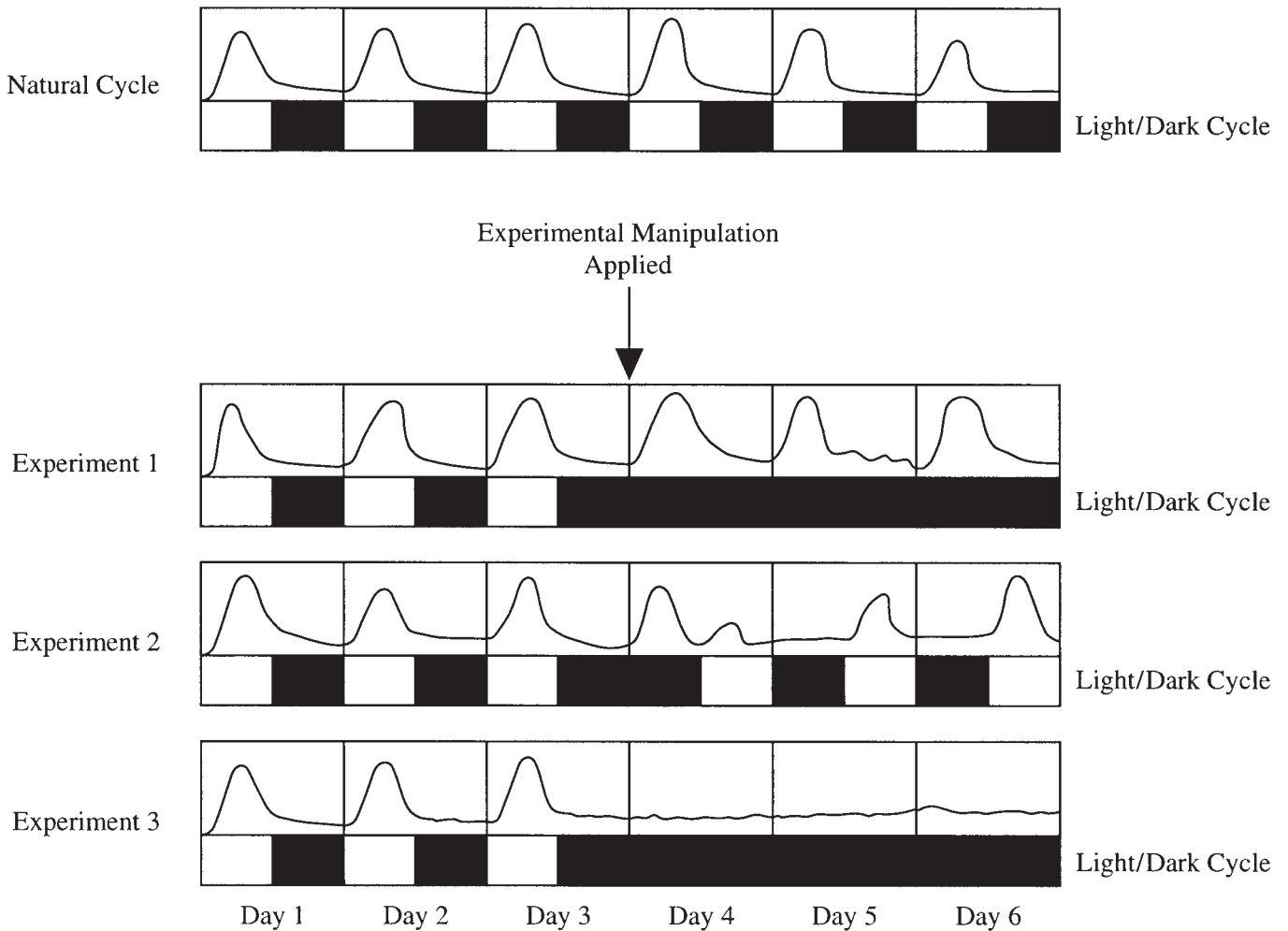

GO ON TO THE NEXT PAGE.

Unauthorized copying or reuse of  
any part of this test is illegal.

157. The pattern of activity recorded in experiment 1 is best described as
- (A) initiation of activity by turning on the lights
  - (B) cessation of activity by turning off the lights
  - (C) an activity pattern controlled by temperature
  - (D) a circadian rhythm
  - (E) a circannual rhythm
158. All of the following characteristics of an endogenous activity cycle are indicated by these experiments EXCEPT:
- (A) The cycles persist under constant conditions.
  - (B) The onset of activity shifts as a result of changing day length.
  - (C) The timing of activity can be reset by environmental stimuli.
  - (D) The period of the cycle approximates 24 hours.
  - (E) The activity cycles may be related to the natural daily light/dark cycle.
159. Which of the following best supports the hypothesis that the pineal gland controls the endogenous activity cycle?
- (A) Birds with an intact pineal gland maintain a typical activity cycle on a normal light/dark cycle.
  - (B) Birds with an intact pineal gland maintain a typical activity cycle when placed in constant dark.
  - (C) When the pineal gland is removed, the activity cycle disappears in birds maintained in constant dark.
  - (D) When the pineal gland is intact, the activity cycle of birds shifts when the light/dark cycle is shifted.
  - (E) The activity cycle persists in birds without a pineal gland when they are maintained on a normal light/dark cycle.
160. If all of the following experiments were performed, which would best test the hypothesis that the pineal gland controls the endogenous activity cycle?
- (A) Transplanting intact pineal glands into pinealectomized birds to determine whether the activity cycle is reestablished
  - (B) Repeating experiment 3 with a different species of bird
  - (C) Repeating experiment 2, but using pinealectomized birds to determine whether they can shift their activity to the changed light/dark cycle
  - (D) Repeating experiment 3 several more times to establish that the same results always occur in pinealectomized birds
  - (E) Using the same procedures as in experiment 3, but removing the thyroid gland instead of the pineal gland to demonstrate that only pinealectomy abolishes the activity cycle

GO ON TO THE NEXT PAGE.

Questions 161-165

Two types of preparations from leaves were used to determine whether photosynthesis can provide energy for synthesis of a particular chloroplast protein (CP). Identical amounts of  $^{14}\text{C}$  amino acids were introduced into preparations of whole-cell homogenates and of isolated chloroplasts, each containing equal quantities of chlorophyll. As indicated in the table below, reactions were carried out in light or dark. After each reaction was terminated, labeled CP was isolated and counted. Additives used in treatments 5, 6, and 7 were supplied before the introduction of  $^{14}\text{C}$  amino acids.

SYNTHESIS OF CHLOROPLAST PROTEIN (CP)

<u>Treatment</u>	<u>Preparation</u>	<u>Condition</u>	<u>Additives</u>	<u>Amino Acid Incorporation</u> (counts per minute/mg chlorophyll/hr)
1.	Chloroplasts	Dark	-----	56
2.	Chloroplasts	Light	-----	525,315
3.	Whole-cell homogenates	Dark	-----	25,650
4.	Whole-cell homogenates	Light	-----	150,418
5.	Chloroplasts	Dark	ATP	446,519
6.	Chloroplasts	Light	ATP	525,313
7.	Chloroplasts	Light	DCMU	41,740

161. Which of the following is the best conclusion from the results of treatments 1 and 2 ?

- (A) The synthesis of CP by chloroplasts requires light.
- (B) The synthesis of CP by chloroplasts requires photosynthesis.
- (C) The synthesis of CP by chloroplasts requires dark.
- (D) Chloroplasts photosynthesize in the light.
- (E) Chloroplasts respire in the dark.

162. Which of the following is the best conclusion from the results of treatments 1, 2, 3, and 4 ?

- (A) Whole-cell homogenates contain no chloroplasts.
- (B) Whole-cell homogenates contain nuclei and mitochondria.
- (C) In the dark, whole-cell homogenates make no CP.
- (D) In the dark, whole-cell homogenates are less effective than chloroplasts are in synthesizing CP.
- (E) In the dark, a component of the whole-cell homogenate is required for the synthesis of CP.

GO ON TO THE NEXT PAGE.

163. Which of the following is the best conclusion about whole-cell homogenates in the light?
- (A) They have mitochondria and nuclei that code for the synthesis of CP.
  - (B) They photosynthesize more than isolated chloroplasts do.
  - (C) They make some intermediate needed for the synthesis of CP in smaller amounts than are made in the dark.
  - (D) They make some component needed for the synthesis of CP in larger amounts than are made in the dark.
  - (E) They make none of the intermediates needed for the synthesis of CP.
164. If treatments 1 and 2 are used as controls, which of the following is the best conclusion from the results of treatments 5 and 6 ?
- (A) Exogenous ATP has no effect on the synthesis of CP in the light or in the dark.
  - (B) Exogenous ATP stimulates the synthesis of CP in the light above control levels.
  - (C) Exogenous ATP stimulates CP synthesis in whole-cell homogenates.
  - (D) ATP inhibits the synthesis of CP.
  - (E) ATP added to dark-incubated preparations stimulates CP synthesis to a level about 85% of that in the light.
165. Which of the following can be best concluded about the added DCMU, a known inhibitor of photosystem II ?
- (A) It blocked all photosynthetic ATP formation and, since some CP synthesis remained, ATP is not required for the process.
  - (B) It blocked ATP formation associated with noncyclic electron flow, but probably not that associated with cyclic electron flow.
  - (C) It is required for the synthesis of CP.
  - (D) It would probably increase the synthesis of CP in whole-cell homogenates.
  - (E) It would probably increase the synthesis of CP by chloroplasts in the dark.

GO ON TO THE NEXT PAGE.

Questions 166-169 refer to the following experiment, which is designed to test the coevolutionary relationships among an unpalatable butterfly (the monarch), a palatable butterfly (the viceroy), and a butterfly predator (the jay).

Monarch butterflies are reared on three diets: milkweed (their natural food), cabbage, and cabbage treated with an extract from milkweed leaves. Viceroy butterflies, mimics of monarchs, also are reared on three diets: willows (their natural food), cabbage, and cabbage treated with an extract from milkweed leaves.

In trial 1 of the first experiment, adult butterflies reared on a particular diet are presented one at a time at 1-hour intervals to jays and the jays are allowed to feed. Each jay is fed until it refuses to eat the butterfly presented, but no more than 12 butterflies are presented to a jay during a particular test. Five birds are used for each test; therefore, up to 60 butterflies can be consumed for each diet test. The observer records the actual number of butterflies eaten. In trial 2, the experiment is repeated 2 weeks later.

In the second experiment, the butterflies are reared on the same diets as in experiment 1. However, when they are offered to jays, some jays receive a monarch reared on milkweed before being offered the butterflies reared on the experimental diets; the other group of jays is first given a viceroy reared on willow before being offered the butterflies reared on the experimental diets. The initial butterfly offered is included in the total number eaten, but no more than 12 butterflies are presented to each jay.

TOTAL NUMBER OF BUTTERFLIES  
INGESTED BY JAYS

<u>Butterfly and Diet</u>	<u>Experiment 1</u>		<u>Experiment 2</u>	
	<u>Trial 1</u>	<u>Trial 2</u>	<u>Fed Monarch First</u>	<u>Fed Viceroy First</u>
<u>Monarch</u>				
Milkweed	5	5	5	10
Cabbage	56	58	5	57
Cabbage with extract	11	10	5	10
<u>Viceroy</u>				
Willow	58	55	5	56
Cabbage	53	57	5	52
Cabbage with extract	54	56	5	59

GO ON TO THE NEXT PAGE.

166. The data in the table indicate which of the following?
- (A) The diet of viceroy butterflies protects them from being eaten by jays.
  - (B) Cabbage contains defensive compounds.
  - (C) Monarch butterflies synthesize a compound that protects them from being eaten by jays.
  - (D) Monarch butterflies obtain a compound from their natural diet that protects them from being eaten by jays.
  - (E) Jays prefer to eat viceroys that have fed on willow.
167. Which of the following supports the hypothesis that viceroys receive protection from predation because they resemble monarchs?
- (A) Fewer monarchs than viceroys are eaten when butterflies are reared on their natural diets.
  - (B) Fewer viceroys are eaten when jays are fed monarchs first.
  - (C) More monarchs are eaten when jays are fed viceroys first.
  - (D) More viceroys than monarchs are eaten when reared on cabbage with extract.
  - (E) Fewer viceroys are eaten when both species are reared on cabbage.
168. The experimental design and the data indicate which of the following about the jays?
- (A) Jays learn to avoid eating monarchs by experience.
  - (B) Jays have a built-in instinct that enables them to recognize and avoid eating monarchs.
  - (C) Eating a single monarch causes a jay to avoid eating another monarch for an indefinite period.
  - (D) A jay needs to eat many monarchs before it decides that monarchs are unpalatable.
  - (E) Jays easily distinguish between monarchs and viceroys.
169. In the experiment, which data in the table most strongly indicate that viceroys are not obtaining compounds that will make them unpalatable?
- (A) Equal numbers of monarchs and viceroys are eaten when each species is reared on cabbage.
  - (B) Fewer monarchs than viceroys are eaten when each species is reared on its natural diet.
  - (C) Jays eat as many viceroys reared on cabbage with extract as on cabbage alone.
  - (D) Jays eat as many viceroys that are reared on willow, their natural food, as those reared on cabbage.
  - (E) There is no difference between trial 1 and trial 2 in the number of viceroys fed cabbage with extract who were eaten by jays.

GO ON TO THE NEXT PAGE.

Questions 170-171

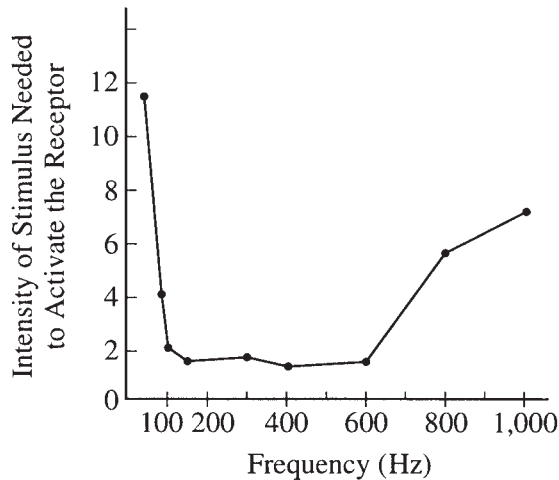

The figure above depicts the intensity *versus* frequency curve of an acoustical receptor of the larva of a noctuid moth. The larva is preyed on by a wasp whose vibrating wings produce a buzz.

170. On the basis of the figure, it can be predicted that the wasp buzz has a frequency
- (A) less than 100 Hz
  - (B) between 100 and 600 Hz
  - (C) of 800 Hz
  - (D) of 1,000 Hz
  - (E) greater than 1,000 Hz

171. The acoustical receptors are destroyed on a population of larvae and rates of wasp predation are measured on the “deaf” larvae and on a population of normal larvae. Based on the curve in the figure and on the concept that animals possess sensory mechanisms that enhance survival, one could correctly predict which of the following?
- (A) Predation intensity on normal and “deaf” larvae would not differ because wasps hunt visually and both larval populations would be equally visible.
  - (B) Predation intensity would be greater on “deaf” larvae because the wasps could approach more closely before being detected and there would be less time for escape.
  - (C) Predation intensity would be greater on the normal larvae because they are attracted to the wasp buzz.
  - (D) Predation intensity on normal and on “deaf” larvae would not differ because the larvae are too slow to escape the approaching wasp.
  - (E) There would be no difference in predation on normal and on “deaf” larvae because sensory mechanisms are used mainly for intraspecies communication.

GO ON TO THE NEXT PAGE.



Questions 172-174

The herbaceous plant *Achillea lanulosa* is widespread in the Northern Hemisphere. Phenotypic variation in the species has been extensively studied along an altitudinal gradient from sea level to over 3,000 meters. In California there is conspicuous variation in height; alpine plants are only several centimeters tall while those in the San Joaquin Valley may reach a height of 1.8 meters. Adaptation to different local environments also results in variation in physiological processes such as photosynthetic rate, resistance to cold, and the timing of dormancy.

172. Which of the following methods would be best to determine whether the phenotypic variation in *Achillea lanulosa* is due to genotypic variation?
- (A) Determining whether viable hybrids between phenotypically different populations can be produced
  - (B) Looking for chromosomal differences between populations at the extremes of the altitudinal range
  - (C) Determining whether phenotypic differences are maintained when plants from different altitudes are grown under the same environmental conditions
  - (D) Assessing the amount of phenotypic variation within populations along the entire altitudinal range
  - (E) Determining whether hybrids between phenotypically different populations grow at altitudes intermediate between the parent populations

173. The morphological variation shown by *Achillea lanulosa* illustrates
- (A) introgressive hybridization
  - (B) Bergmann's rule
  - (C) speciation
  - (D) genetic drift
  - (E) ecotypic variation
174. The genetic polymorphism found in *Achillea lanulosa* is most likely maintained primarily by
- (A) reproductive isolating mechanisms
  - (B) inbreeding
  - (C) natural selection
  - (D) the suppression of outcrossing
  - (E) genetic recombination

GO ON TO THE NEXT PAGE.

Questions 175-178

Nuclei from both the liver and brain cells of a rat are isolated and incubated with highly radioactive RNA precursors. The RNA transcripts synthesized in these nuclei become radioactively labeled. These radioactive RNA molecules are incubated with a single-stranded DNA segment (cDNA) complementary to an mRNA molecule found in liver-cell cytoplasm but not brain-cell cytoplasm. The RNA and DNA are allowed to form RNA/DNA hybrid double helices with the specific cDNA probe. An RNA-digesting enzyme is added to destroy RNA that is not in hybrid form. Radioactivity in the remaining hybrids is measured as counts per minute.

The results are presented in the table below.

<u>Incubation Components</u>	<u>Counts per Minute</u>
Liver cDNA probe plus primary RNA transcripts from liver-cell nuclei	15,000
Liver cDNA probe plus primary RNA transcripts from brain-cell nuclei	150

175. Which of the following statements concerning the DNA sequence corresponding to this liver-specific mRNA molecule is best supported by the data?
- (A) It is transcribed in brain-cell nuclei only.
  - (B) It is transcribed in both brain- and liver-cell nuclei at approximately the same rate.
  - (C) It is not transcribed in brain-cell nuclei but is transcribed in liver-cell nuclei.
  - (D) It is not transcribed in either liver- or brain-cell nuclei.
  - (E) It may be transcribed in both brain- and liver-cell nuclei but cannot be detected by this experimental procedure.
176. To produce radiolabeled transcripts, the isolated nuclei from both liver and brain must have which of the following?
- (A) DNA polymerase
  - (B) RNA polymerase
  - (C) Reverse transcriptase
  - (D) Ribosomes
  - (E) Plasmid DNA

GO ON TO THE NEXT PAGE.

177. To make the single-stranded cDNA used in this experiment, which of the following enzymes was required?

- (A) DNA polymerase
- (B) Reverse transcriptase
- (C) DNase
- (D) Protease
- (E) Protein kinase

178. The regulation of the expression of mRNA in the isolated nuclei from the two cell types as demonstrated in this experiment is an example of

- (A) translational control
- (B) mRNA degradation control
- (C) transcriptional control
- (D) transport control
- (E) lack of control

GO ON TO THE NEXT PAGE.

Questions 179-180

A series of experiments is designed to investigate the relationship of the thyroid gland to metabolism (oxygen consumption) and protein synthesis in rats. Thyroxine is the major hormone produced by the thyroid gland. Rats may be thyroidectomized (THX) either surgically or chemically.

Experimental and control animals are tested by measuring oxygen consumption in a respirometer for 1 hour and by measuring incorporation of injected tritiated leucine ( $^3\text{H-leu}$ ) into the liver. At various times after injection, the rats are sacrificed and the radioactivity in the liver is measured. The data are recorded in the table below.

	Oxygen Consumption ( $\text{mL} \cdot \text{gram}^{-1} \cdot \text{hr}^{-1}$ )	Incorporation of Label ( $\mu\text{moles} \cdot \text{gram}^{-1} \cdot \text{hr}^{-1}$ )
THX rats	23.4	154
Rats with thyroid gland	32.6	214

179. Which of the following statements is consistent with the data?

- (A) Thyroidectomy increases protein synthesis and oxygen consumption.
- (B) Thyroidectomy increases protein synthesis and decreases oxygen consumption.
- (C) Thyroxine increases the rate of protein synthesis and oxygen consumption.
- (D) Thyroxine affects oxygen consumption but has no effect on protein synthesis.
- (E) Protein synthesis and oxygen consumption respond differently to thyroidectomy.

180. To confirm further the relationship of the thyroid gland to respiration and protein synthesis, one should do which of the following?

- (A) Inject thyroxine into the control rats and take the measurements again.
- (B) Inject thyroxine into the THX rats and take the measurements again.
- (C) Inject Ringer's solution into the THX rats and take the measurements again.
- (D) Feed thyroxine to the control rats and take the measurements again.
- (E) Feed iodine to the THX rats and take the measurements again.

GO ON TO THE NEXT PAGE.

Questions 181-182 refer to the immediate areas around the letters in the following profile of a continent.

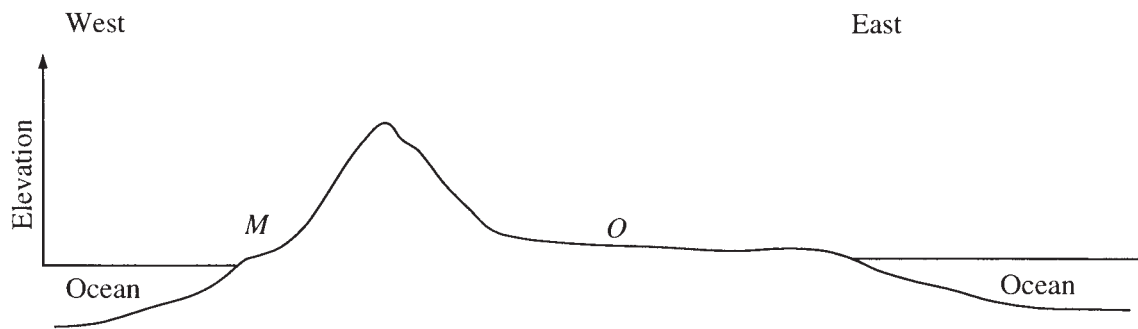

181. At latitudes of 20 to 30 degrees north or south and with prevailing winds from east to west, the most likely biome to develop at *M* would be a

- (A) monsoon forest
- (B) tundra
- (C) desert
- (D) rain forest
- (E) deciduous forest

182. A rain forest would most likely develop at both *M* and *O*, regardless of the prevailing winds, at which latitude?

- (A) 0 degrees
- (B) 20 degrees
- (C) 40 degrees
- (D) 60 degrees
- (E) 90 degrees

GO ON TO THE NEXT PAGE.

Questions 183-186

To determine the intracellular pathways of three proteins, X, Y, and Z, four identical cultures of cells were labeled with  $^3\text{H}$ -amino acids for 5 minutes. One culture was harvested at the end of the 5-minute labeling period. The other three cultures were rinsed and then were put into media with twentyfold excess of unlabeled amino acids for 10 minutes, 20 minutes, and 30 minutes, respectively, before harvesting. After harvesting, the cells were put on ice and broken open, and the cellular fractions were obtained by differential centrifugation. The cellular fractions harvested include: mitochondria, rough endoplasmic reticulum (rough ER), Golgi apparatus, plasma membranes, free ribosomes, and soluble cellular supernatant (cytosol). In each of these fractions, the amount of newly synthesized protein was determined. The data, expressed as the percentage of the total newly synthesized protein of a particular type in each fraction, were recorded in the table below.

Harvest Time	5 min.			10 min.			20 min.			30 min.		
Protein	X	Y	Z	X	Y	Z	X	Y	Z	X	Y	Z
<u>Fraction</u>												
Mitochondria	0	0	0	0	0	0	0	0	50	0	0	100
Rough ER	0	100	0	0	75	0	0	10	0	0	0	0
Golgi apparatus	0	0	0	0	25	0	0	50	0	0	20	0
Plasma membrane	0	0	0	0	0	0	0	40	0	0	80	0
Ribosomes	100	0	100	25	0	0	0	0	0	0	0	0
Cytosol	0	0	0	75	0	100	100	0	50	100	0	0

GO ON TO THE NEXT PAGE.

Unauthorized copying or reuse of  
any part of this test is illegal.

183. The association of proteins *X* and *Z* with free ribosomes at a harvest time of 5 minutes indicates which of the following about the proteins?
- (A) They are ribosomal proteins.
  - (B) They are at the site of synthesis.
  - (C) They are glycosylated proteins.
  - (D) There is an artifact in the measurement.
  - (E) They are identical.
184. The inferred steps in the pathway of protein *Y* are correctly designated by which of the following?
- (A) Endoplasmic reticulum → Golgi apparatus → plasma membrane
  - (B) Endoplasmic reticulum  $\begin{matrix} \nearrow \text{plasma membrane} \\ \searrow \text{Golgi apparatus} \end{matrix}$
  - (C) Plasma membrane → Golgi apparatus → endoplasmic reticulum
  - (D) Plasma membrane  $\begin{matrix} \nearrow \text{endoplasmic reticulum} \\ \searrow \text{Golgi apparatus} \end{matrix}$
  - (E) Golgi apparatus → endoplasmic reticulum
185. Protein *Z* would be considered a
- (A) ribosomal protein
  - (B) cytosolic protein
  - (C) mitochondrial protein
  - (D) plasma membrane protein
  - (E) Golgi apparatus protein
186. At a harvest time of 10 minutes, which of the following statements is correct about protein *X* compared with protein *Z* ?
- (A) Protein *X* is synthesized more rapidly than protein *Z*.
  - (B) Protein *X* is degraded more slowly than protein *Z*.
  - (C) Protein *X* is degraded more rapidly than protein *Z*.
  - (D) Protein *X* is released from ribosomes more slowly than protein *Z*.
  - (E) Protein *X* is released from ribosomes more rapidly than protein *Z*.

GO ON TO THE NEXT PAGE.

Questions 187-190

The apical meristem of root tips of maize (*Zea mays*) has a quiescent (inactive) center, together with actively dividing cells that initiate the root cap or stele (vascular tissue). Root tips were subjected to acute x-irradiation at two dosages, which affected mitosis and cell division in the three regions, as shown below.

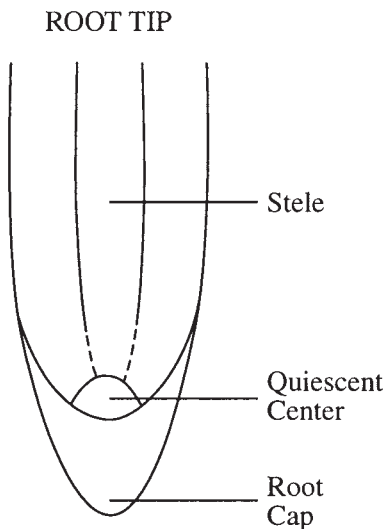

AVERAGE DURATIONS OF THE CELL CYCLE (IN HOURS)  
AFTER ACUTE X-IRRADIATION

Dose (rad)	Time After Irradiation (days)	Quiescent Center	Dividing Cells of Root Cap	Stele (vascular-tissue)
0	—	174	12	28
900	3	89	54	44
"	6	124	52	60
1,800	3	62	134	137
"	6	64	149	86
"	9	181	56	56

187. The first change in the quiescent center in irradiated roots, as shown in the table, was
- (A) an increase in the number of polyploid cells
  - (B) an increase in the length of the cell cycle
  - (C) a decrease in the number of cell cycles
  - (D) a decrease in the length of the cell cycle
  - (E) a decrease in total cell number

188. Increased dosages of irradiation had which of the following effects?
- (A) Shorter cell cycle in quiescent center cells at high dosage than at low dosage
  - (B) Longer duration of cell cycle in quiescent center cells at high dosage than at low dosage
  - (C) Shorter duration of cell cycle in meristematic cells of the cap and stele at high than at low dosage
  - (D) Uniformity of rates in all regions
  - (E) Cessation of division in all cells in the root tip

GO ON TO THE NEXT PAGE.



189. Six to nine days after irradiation, which of the following statements is correct about the cells of the quiescent center?
- (A) They retained a high level of mitotic activity.
  - (B) They returned to a relatively low level of mitotic activity.
  - (C) The level of mitotic activity continued to fluctuate.
  - (D) They retained a permanent low level of mitotic activity.
  - (E) They were suspended in the  $G_1$  phase of the cell cycle.
190. The quiescent center in roots of maize is significant because
- (A) root meristems are not responsible for root growth
  - (B) irradiation damages all root meristem cells equally
  - (C) quiescent center cells can continue meristem growth if other meristem cells are damaged by irradiation
  - (D) the quiescent center cells will have the most radiation damage of all the meristem cells
  - (E) the quiescent center is a laboratory artifact

GO ON TO THE NEXT PAGE.

Questions 191-193

In bottom sediments of lakes and streams, organic matter is broken down by heterotrophic microorganisms and ammonia is released. Under aerobic conditions, specialized bacteria convert ammonia to nitrate (nitrification). This nitrate, together with nitrate from other sources, diffuses into the deeper sediments, where it may undergo anaerobic conversion to nitrogen gas (denitrification). These sediments typically contain oligochaete worms that live with their heads buried and their tails waving back and forth in the overlying water.

Plastic columns were packed with freshly collected stream sediments and then covered with layers of nitrate-enriched water. A similar set of columns was packed with sediment that had been sterilized and then covered with either nitrate-enriched water or distilled water. Oligochaete worms were collected and acclimated to 20°C. Following acclimation, worms were rinsed in distilled water and then added to three sediment columns.

The columns were incubated in the dark at 20°C and monitored every three days for changes in the concentration of nitrate in the overlying water. Nitrate concentrations in each of the experimental treatments were plotted against time, as shown in the graph below.

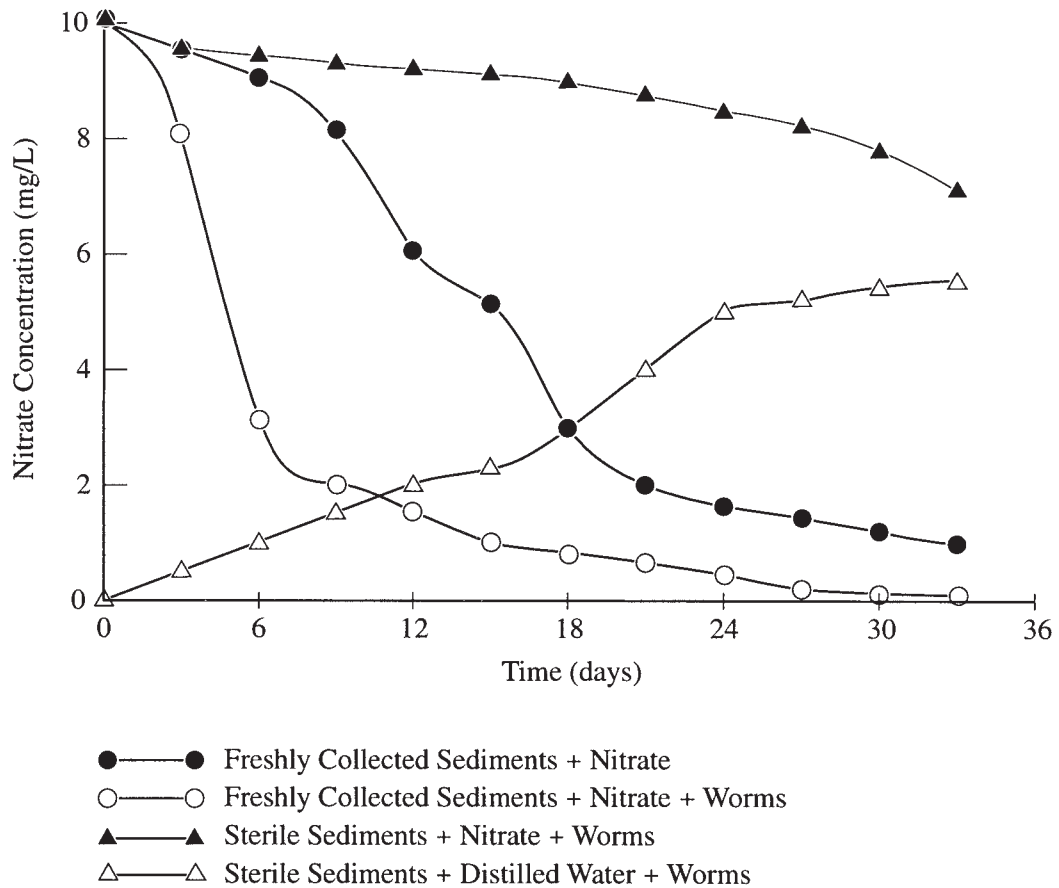

GO ON TO THE NEXT PAGE.

Unauthorized copying or reuse of  
any part of this test is illegal.

191. It can be concluded from the figure that
- (A) the presence of oligochaete worms increases the rate of denitrification
  - (B) the presence of oligochaete worms decreases the rate of denitrification
  - (C) the presence of sediment microorganisms decreases the rate of denitrification
  - (D) oligochaete worms carry out denitrification in the absence of sediment microorganisms
  - (E) sediment microorganisms are unable to carry out denitrification in the absence of oligochaete worms
192. The best explanation for the increase in nitrate concentration in one treatment is that
- (A) oligochaete worms may harbor microorganisms that are capable of carrying out nitrification
  - (B) oligochaete worms are capable of carrying out a limited amount of denitrification in the absence of sediment microorganisms
  - (C) some nitrifying bacteria must have survived the autoclaving in the form of spores
  - (D) some denitrifying bacteria may have been added to the columns along with the oligochaete worms
  - (E) burrowing activities of the oligochaete worms increase the rate of diffusion of nitrate into the deeper anaerobic sediment layers
193. Which of the following explains why the columns were incubated in the dark?
- (A) Oligochaete worms are nocturnal.
  - (B) Microbial nitrification is inhibited by light.
  - (C) Microbial denitrification is inhibited by light.
  - (D) Photosynthetic organisms might compete with sediment microorganisms for nitrate in the light.
  - (E) Nitrate in sterile sediments is spontaneously reduced to nitrogen gas in the dark.

GO ON TO THE NEXT PAGE.

Questions 194-195

A freshly isolated population of mature human red blood cells was rapidly loaded with radioactive sodium and then subdivided into equally sized samples. The samples were incubated in isosmotic media containing 120-millimolar sodium chloride and different concentrations of potassium chloride, under otherwise identical conditions. In the graph below, the rates at which sodium left the cells are plotted as a function of the extracellular potassium concentrations.

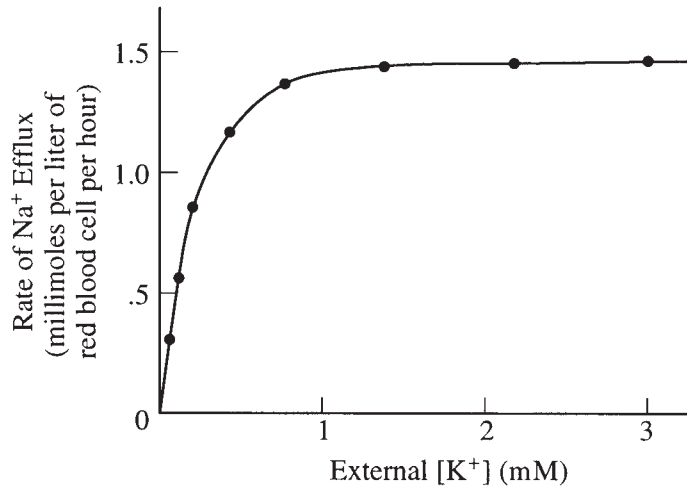

194. The rate of sodium efflux reaches a plateau at about 1.0 mM external potassium, because at that concentration potassium
- (A) competes with sodium for transport
  - (B) occupies all the potassium-binding sites on the sodium carriers
  - (C) makes the membrane impermeable to sodium
  - (D) precipitates out of solution
  - (E) binds ATP, thereby lowering the substrate concentration
195. Which of the following mechanisms best accounts for the sodium efflux observed in the graph?
- (A) Simple diffusion
  - (B) Active transport
  - (C) Cooperativity
  - (D) Receptor-mediated exocytosis
  - (E) Facilitated diffusion

GO ON TO THE NEXT PAGE.

Questions 196-198

After sperm entry, the cytoplasm of the amphibian egg rearranges to form an equatorial crescent between the animal pole and vegetal pole. After cleavage, crescent cells involute during gastrulation to form mesoderm. Differentiated mesodermal cells produce a specific type of actin. To investigate mesodermal differentiation, two experiments were performed. In experiment 1, cells were isolated from the embryo at various stages and assayed for mesodermal actin. (+ indicates the presence of mesodermal actin.)

<u>Experiment 1</u>		
<u>Embryonic Stage</u>	<u>Isolated Cell Type</u>	<u>Mesodermal Actin</u>
32 cells	Crescent cells	–
	Animal pole cells	–
	Vegetal pole cells	–
128 cells	Crescent cells	–
	Animal pole cells	–
	Vegetal pole cells	–
512 cells	Crescent cells	+
	Animal pole cells	–
	Vegetal pole cells	–

In experiment 2, three different cell types from the 32-cell stage were isolated and recombined, as shown below. Later each cell type was assayed for mesodermal actin. The results are shown in the table below.

<u>Experiment 2</u>				
<u>Embryonic Stage</u>	<u>Treatment</u>	<u>Mesodermal Actin</u>		
		<u>Animal Cells</u>	<u>Vegetal Cells</u>	<u>Crescent Cells</u>
32 cells	Animal pole cells + vegetal pole cells	+	–	–
	Vegetal pole cells + crescent cells	–	–	+
	Animal pole cells + crescent cells	–	–	–

196. As measured by the appearance of actin in experiment 1, mesoderm most likely differentiates
- (A) before the 32-cell stage
  - (B) between the 32- and 128-cell stages
  - (C) at the 128-cell stage
  - (D) between the 128- and 512-cell stages
  - (E) after the 512-cell stage
197. Which of the following is the most logical conclusion based on the results of both experiments?
- (A) Animal pole cells induce the mesoderm.
  - (B) Vegetal pole cells induce the mesoderm.
  - (C) Crescent cells induce the mesoderm.
  - (D) Animal pole cells self-differentiate as mesoderm.
  - (E) Crescent cells self-differentiate as mesoderm.
198. When isolated from the 32-cell embryo, animal pole cells will produce an ectoderm-specific protein and isolated vegetal pole cells will produce an endoderm-specific protein. These observations and those of experiment 2 indicate that animal pole cells are competent to differentiate as
- (A) mesoderm only
  - (B) ectoderm only
  - (C) endoderm only
  - (D) mesoderm and ectoderm
  - (E) endoderm and ectoderm

Questions 199-200

A common method of measuring community productivity in a pond is by measuring oxygen production or consumption in light (transparent) and dark (opaque) bottles filled with pond water. The oxygen concentration in each bottle is measured, the bottles are sealed, and then suspended from floats near the surface of the pond. After 24 hours, the oxygen concentration is again measured in each bottle. Representative data are presented below.

$$\text{Initial oxygen concentration (Initial)} = 10 \text{ mg} \cdot \text{L}^{-1}$$

$$\text{Oxygen concentration in light bottle after 24 hours (Light)} = 12 \text{ mg} \cdot \text{L}^{-1}$$

$$\text{Oxygen concentration in dark bottle after 24 hours (Dark)} = 7 \text{ mg} \cdot \text{L}^{-1}$$

199. Daily respiration can be determined by which of the following calculations?

(A)  $\text{Light (12 mg} \cdot \text{L}^{-1}) - \text{Initial (10 mg} \cdot \text{L}^{-1}) = 2 \text{ mg} \cdot \text{L}^{-1}$  oxygen

(B)  $\text{Light (12 mg} \cdot \text{L}^{-1}) - \text{Dark (7 mg} \cdot \text{L}^{-1}) = 5 \text{ mg} \cdot \text{L}^{-1}$  oxygen

(C)  $\text{Initial (10 mg} \cdot \text{L}^{-1}) - \text{Dark (7 mg} \cdot \text{L}^{-1}) = 3 \text{ mg} \cdot \text{L}^{-1}$  oxygen

(D)  $\text{Initial (10 mg} \cdot \text{L}^{-1}) + \text{Dark (7 mg} \cdot \text{L}^{-1}) = 17 \text{ mg} \cdot \text{L}^{-1}$  oxygen

(E)  $\text{Dark (7 mg} \cdot \text{L}^{-1}) + 1/2 \text{ Light (6 mg} \cdot \text{L}^{-1}) = 13 \text{ mg} \cdot \text{L}^{-1}$  oxygen

200. After 24 hours, the light bottle had a higher concentration of oxygen ( $12 \text{ mg} \cdot \text{L}^{-1}$ ) than it did initially ( $10 \text{ mg} \cdot \text{L}^{-1}$ ). This difference represents

(A) gross primary production

(B) net primary production

(C) secondary production

(D) net community respiration

(E) respiration by plants

IF YOU FINISH BEFORE TIME IS CALLED, YOU MAY CHECK YOUR WORK ON THIS TEST.

Unauthorized copying or reuse of  
any part of this test is illegal.



NOTE: To ensure prompt processing of test results, it is important that you fill in the blanks exactly as directed.

SUBJECT TEST

A. Print and sign your full name in this box:

PRINT: \_\_\_\_\_  
 (LAST) (FIRST) (MIDDLE)  
 SIGN: \_\_\_\_\_

Copy this code in box 6 on your answer sheet. Then fill in the corresponding ovals exactly as shown.

6. TITLE CODE				
2	4	0	2	3
○0	○0	●	○0	○0
○1	○1	○1	○1	○1
●	○2	○2	●	○2
○3	○3	○3	○3	●
○4	●	○4	○4	○4
○5	○5	○5	○5	○5
○6	○6	○6	○6	○6
○7	○7	○7	○7	○7
○8	○8	○8	○8	○8
○9	○9	○9	○9	○9

Copy the Test Name and Form Code in box 7 on your answer sheet.

TEST NAME Biology  
 FORM CODE GR9924

GRADUATE RECORD EXAMINATIONS SUBJECT TEST

B. The Subject Tests are intended to measure your achievement in a specialized field of study. Most of the questions are concerned with subject matter that is probably familiar to you, but some of the questions may refer to areas that you have not studied.

Your score will be determined by subtracting one-fourth the number of incorrect answers from the number of correct answers. Questions for which you mark no answer or more than one answer are not counted in scoring. If you have some knowledge of a question and are able to rule out one or more of the answer choices as incorrect, your chances of selecting the correct answer are improved, and answering such questions will likely improve your score. It is unlikely that pure guessing will raise your score; it may lower your score.

You are advised to use your time effectively and to work as rapidly as you can without losing accuracy. Do not spend too much time on questions that are too difficult for you. Go on to the other questions and come back to the difficult ones later if you can.

YOU MUST INDICATE ALL YOUR ANSWERS ON THE SEPARATE ANSWER SHEET. No credit will be given for anything written in this examination book, but you may write in the book as much as you wish to work out your answers. After you have decided on your response to a question, fill in the corresponding oval on the answer sheet. BE SURE THAT EACH MARK IS DARK AND COMPLETELY FILLS THE OVAL. Mark only one answer to each question. No credit will be given for multiple answers. Erase all stray marks. If you change an answer, be sure that all previous marks are erased completely. Incomplete erasures may be read as intended answers. Do not be concerned that the answer sheet provides spaces for more answers than there are questions in the test.

Example:

What city is the capital of France?

- (A) Rome
- (B) Paris
- (C) London
- (D) Cairo
- (E) Oslo

Sample Answer

○A ● C ○D ○E  
 ○A ✗ C ○D ○E  
 ○A ✓ C ○D ○E  
 ○A ● C ○D ○E  
 ○A ○ C ○D ○E

CORRECT ANSWER PROPERLY MARKED

IMPROPER MARKS

**DO NOT OPEN YOUR TEST BOOK UNTIL YOU ARE TOLD TO DO SO.**



Educational Testing Service  
 Princeton, New Jersey 08541



## Scoring Your Subject Test

Biology Test scores typically range from 490 to 790. The range for different editions of a given test may vary because different editions are not of precisely the same difficulty. The differences in ranges among different editions of a given test, however, usually are small. This should be taken into account, especially when comparing two very high scores. In general, differences between scores at the 99th percentile should be ignored. **The score conversion table on page 67 shows the score range for this edition of the test only.**

Subscores are reported as two-digit scaled scores. The maximum possible range of Subject Test subscores is 20 to 99. Like total scores, the actual range of subscores for any test or test edition may be smaller than 20 to 99.

The worksheet on page 66 lists the correct answers to the questions. Columns are provided for you to mark whether you chose the correct (C) answer or an incorrect (I) answer to each question. Draw a line across any question you omitted, because it is not counted in the scoring. At the bottom of the page, enter the total number correct and the total number incorrect. Divide the total incorrect by 4 and subtract the resulting number from the total correct. This is the adjustment made for guessing. Then round the result to the nearest whole number. This will give you your raw total score. Use the total score conversion table to find the scaled total score that corresponds to your raw total score.

Example: Suppose you chose the correct answers to 105 questions and incorrect answers to 41. Dividing 41 by 4 yields 10.3. Subtracting 10.3 from 105 equals 94.7, which is rounded to 95. The raw score of 95 corresponds to a scaled score of 630.

The subscore columns in the worksheet can be similarly used to tally your correct and incorrect responses to the questions that contribute to each subscore. We suggest that you circle the “●” if you chose the correct answer, and put a minus sign beside the “●” for an incorrect answer. Space is provided at the bottom right of the worksheet to calculate and enter your three raw subscores. The subscore conversion table will show you the scaled subscores that correspond to your raw subscores.

## Worksheet for the Biology Test, Form GR9924 Only Answer Key and Percentages\* of Examinees Answering Each Question Correctly

QUESTION Number	Answer	P +	TOTAL		SUBSCORE		
			C	I	1	2	3
1	E	53			•		
2	E	60			•		
3	B	87			•		
4	E	44			•		
5	C	83			•		
6	B	84			•		
7	D	36			•		
8	A	34			•		
9	E	57			•		
10	A	75			•		
11	E	62			•		
12	A	32			•		
13	A	51			•		
14	D	55			•		
15	D	25			•		
16	C	37			•		
17	B	38			•		
18	C	44			•		
19	E	60			•		
20	A	44			•		
21	B	33			•		
22	B	31			•		
23	D	69			•		
24	C	69			•		
25	E	23			•		
26	D	36			•		
27	E	26			•		
28	C	25			•		
29	B	22			•		
30	C	27			•		
31	A	19			•		
32	A	78			•		
33	B	50			•		
34	C	23			•		
35	D	49			•		
36	D	34			•		
37	A	61			•		
38	E	21			•		
39	A	43			•		
40	C	34			•		
41	E	34				•	
42	E	85				•	
43	A	79				•	
44	C	41				•	
45	D	61				•	
46	D	43				•	
47	C	22				•	
48	A	57				•	
49	C	83				•	
50	B	21				•	
51	B	51				•	
52	E	81				•	
53	A	23				•	
54	A	42				•	
55	B	59				•	
56	E	48				•	
57	B	63				•	
58	A	65				•	
59	D	37				•	
60	E	25				•	
61	B	89				•	
62	B	28				•	
63	D	15				•	
64	E	23				•	
65	A	43				•	
66	E	62				•	
67	B	35				•	
68	B	26				•	
69	E	54				•	
70	D	36				•	

QUESTION Number	Answer	P +	TOTAL		SUBSCORE		
			C	I	1	2	3
71	D	37			•		
72	C	23			•		
73	D	38			•		
74	E	20			•		
75	E	47			•		
76	D	28			•		
77	C	40			•		
78	D	88			•		
79	C	69				•	
80	D	63				•	
81	A	73				•	
82	B	46				•	
83	B	61				•	
84	D	54				•	
85	C	79				•	
86	B	90				•	
87	C	27				•	
88	A	62				•	
89	A	78				•	
90	C	53				•	
91	A	75				•	
92	D	11				•	
93	C	70				•	
94	D	58				•	
95	E	49				•	
96	A	90				•	
97	C	49				•	
98	B	39				•	
99	D	51				•	
100	A	35				•	
101	E	40				•	
102	C	58				•	
103	C	55				•	
104	C	51				•	
105	A	50				•	
106	D	42				•	
107	C	81				•	
108	A	76				•	
109	C	31				•	
110	D	55				•	
111	C	89				•	
112	E	33				•	
113	E	65				•	
114	E	71				•	
115	A	92				•	
116	C	58				•	
117	C	61				•	
118	A	83				•	
119	B	64				•	
120	A	49				•	
121	E	67				•	
122	C	81				•	
123	D	91				•	
124	C	76				•	
125	B	82				•	
126	D	66				•	
127	E	47				•	
128	C	79				•	
129	D	31				•	
130	A	86				•	
131	C	29				•	
132	D	56				•	
133	E	32				•	
134	A	63				•	
135	C	84				•	
136	A	84				•	
137	B	81				•	
138	C	46				•	
139	D	53				•	
140	B	45				•	

QUESTION Number	Answer	P +	TOTAL		SUBSCORE		
			C	I	1	2	3
141	A	51			•		
142	D	60				•	
143	A	67				•	
144	A	46				•	
145	E	50				•	
146	A	90				•	
147	C	70				•	
148	A	84				•	
149	B	68				•	
150	B	76				•	
151	B	68				•	
152	C	78				•	
153	D	71				•	
154	B	69				•	
155	B	83				•	
156	B	80				•	
157	D	84				•	
158	B	32				•	
159	C	66				•	
160	A	41				•	
161	A	66				•	
162	E	63				•	
163	D	68				•	
164	E	75				•	
165	B	49				•	
166	D	74				•	
167	B	75				•	
168	A	68				•	
169	C	35				•	
170	B	69				•	
171	B	75				•	
172	C	65				•	
173	E	62				•	
174	C	50				•	
175	C	55				•	
176	B	50				•	
177	B	38				•	
178	C	46				•	
179	C	70				•	
180	B	74				•	
181	C	33				•	
182	A	58				•	
183	B	51				•	
184	A	74				•	
185	C	53				•	
186	D	63				•	
187	D	58				•	
188	A	47				•	
189	B	40				•	
190	C	53				•	
191	A	44				•	
192	A	40				•	
193	D	53				•	
194	B	45				•	
195	B	41				•	
196	D	64				•	
197	B	44				•	
198	D	47				•	
199	C	35				•	
200	B	51				•	

Correct (C) \_\_\_\_\_

Incorrect (I) \_\_\_\_\_

Total Score: \_\_\_\_\_

C - I/4 = \_\_\_\_\_

Scaled Score (SS) = \_\_\_\_\_

Subscores:

1) C - I/4 = \_\_\_\_\_ SS = \_\_\_\_\_

2) C - I/4 = \_\_\_\_\_ SS = \_\_\_\_\_

3) C - I/4 = \_\_\_\_\_ SS = \_\_\_\_\_

\*The P+ column indicates the percentage of Biology Test examinees that answered each question correctly; it is based on a sample of December 1999 examinees selected to represent all Biology Test examinees tested between October 1, 1997, and September 30, 2000.

**Score Conversions and Percents  
Below\* for GRE Biology Test,  
Form GR9924 Only**

TOTAL SCORE					
Raw Score	Scaled Score	%	Raw Score	Scaled Score	%
199-200	990	99	81-83	590	37
196-198	980	99	78-80	580	33
193-195	970	99	75-77	570	31
190-192	960	99	72-74	560	27
187-189	950	99	69-71	550	25
184-186	940	99	66-68	540	22
181-183	930	99	63-65	530	19
179-180	920	99	60-62	520	17
176-178	910	99	57-59	510	15
173-175	900	99	54-56	500	12
170-172	890	99	51-53	490	10
167-169	880	98	48-50	480	8
164-166	870	98	45-47	470	7
161-163	860	98	42-44	460	6
158-160	850	97	39-41	450	5
155-157	840	96	36-38	440	4
152-154	830	95	33-35	430	3
149-151	820	94	30-32	420	2
146-148	810	93	28-29	410	2
143-145	800	92	25-27	400	1
140-142	790	91	22-24	390	1
137-139	780	89	19-21	380	1
134-136	770	87	16-18	370	1
131-133	760	85	13-15	360	1
128-130	750	84	10-12	350	1
125-127	740	81	7-9	340	1
122-124	730	79	4-6	330	1
119-121	720	76	1-3	320	1
116-118	710	74	0	310	1
113-115	700	71			
110-112	690	69			
107-109	680	66			
105-106	670	63			
102-104	660	60			
99-101	650	56			
96-98	640	53			
93-95	630	50			
90-92	620	47			
87-89	610	43			
84-86	600	40			

**Score Conversions for  
GRE Biology Test Subscores,  
Form GR9924 Only**

SUBSCORES									
Raw Score			Scaled Score	Raw Score			Scaled Score		
Sub 1	Sub 2	Sub 3		Sub 1	Sub 2	Sub 3			
	62-65		99	26		31	59		
	61		98	25	23	29-30	58		
	60		97	24	22	28	57		
	59		96	22-23	21	27	56		
	58		95	21	20	26	55		
67	57		94	20	19	25	54		
66	56		93	19	18	24	53		
65	55		92	18	17	23	52		
64	54	68	91	16-17	16	21-22	51		
62-63		66-67	90	15	15	20	50		
61	53	65	89	14	14	19	49		
60	52	64	88	13	13	18	48		
59	51	63	87	12	12	17	47		
58	50	62	86	11	11	16	46		
56-57	49	61	85	9-10	10	14-15	45		
55	48	59-60	84	8	9	13	44		
54	47	58	83	7	8	12	43		
53	46	57	82	6	7	11	42		
52	45	56	81	5	6	10	41		
51	44	55	80	3-4	5	9	40		
49-50	43	54	79	2	4	8	39		
48	42	53	78	1	3	6-7	38		
47	41	51-52	77	0	2	5	37		
46	40	50	76		1	4	36		
45	39	49	75		0	3	35		
44	38	48	74			2	34		
42-43	37	47	73			1	33		
41	36	46	72			0	32		
40	35	44-45	71						
39	34	43	70						
38	33	42	69						
36-37	32	41	68						
35	31	40	67						
34	30	39	66						
33	29	38	65						
32	28	36-37	64						
31	27	35	63						
29-30	26	34	62						
28	25	33	61						
27	24	32	60						

\*Percentage scoring below the scaled score is based on the performance of 19,924 examinees who took the Biology Test between October 1, 1997, and September 30, 2000.

## Evaluating Your Performance

Now that you have scored your test, you may wish to compare your performance with the performance of others who took this test. Both the worksheet on page 66 and the tables on page 67 use performance data from GRE Biology Test examinees.

The data in the worksheet on page 66 are based on the performance of a sample of the examinees who took this test in December 1999. This sample was selected to represent the total population of GRE Biology Test examinees tested between October 1997 and September 2000. The numbers in the column labeled “P+” on the worksheet indicate the percentages of examinees in this sample who answered each question correctly. You may use these numbers as a guide for evaluating your performance on each test question.

The first table on page 67 contains, for each scaled score, the percentage of examinees tested between October 1997 and September 2000 who received lower scores. Interpretive data based on the scores earned by examinees tested in this three-year period will be used by admissions officers in the 2001-02 testing year. These percentages appear in the score conversion table in a column to the right of the scaled scores. For example, in the percentage column opposite the scaled score of 630 is the number 50. This means that 50 percent of the GRE Biology Test examinees tested between October 1997 and September 2000 scored lower than 630. To compare yourself with this population, look at the percentage next to the scaled score you earned on the practice test.

Your three subscores show your relative strengths or weaknesses in the three subfield areas of the GRE Biology Test. The raw subscores are scaled in such a way that they are related to the total scores on the test. On the average, a person who has a comprehensive background in the field can expect to have subscores equal to about one-tenth of his or her total score. Thus, if you have a total score of 600, and your undergraduate program placed equal emphasis on the three areas of Biology represented by the subscores, you would expect to have a scaled subscore of about 60 in each area. If, however, your subscores differ by more than a few points, you may take this as an indication that your lower score shows weakness, and you may wish to concentrate your review efforts on topics in that area.

It is important to realize that the conditions under which you tested yourself were not exactly the same as those you will encounter at a test center. It is impossible to predict how different test-taking conditions will affect test performance, and this is only one factor that may account for differences between your practice test scores and your actual test scores. By comparing your performance on this practice test with the performance of other GRE Biology Test examinees, however, you will be able to determine your strengths and weaknesses and can then plan a program of study to prepare yourself for taking the GRE Biology Test under standard conditions.

DO NOT USE INK

Use only a pencil with soft, black lead (No. 2 or HB) to complete this answer sheet. Be sure to fill in completely the space that corresponds to your answer choice. Completely erase any errors or stray marks.

1. NAME. Enter your last name, first name initial (given name), and middle initial if you have one. Omit spaces, apostrophes, Jr., II., etc. Last Name only (Family or Surname) - first 15 letters. First Name Initial. Middle Name Initial. 15 columns for last name, 15 for first name, 15 for middle name.

2. YOUR NAME: Last Name (Family or Surname), First Name (Given), M.I. (Print)

MAILING ADDRESS: P.O. Box or Street Address

City, State or Province, Zip or Postal Code

CENTER: City, State or Province, Zip or Postal Code

Country, Center Number, Room Number

SIGNATURE:

GRADUATE RECORD EXAMINATIONS® - GRE® - SUBJECT TEST SIDE 1

BE SURE EACH MARK IS DARK AND COMPLETELY FILLS THE INTENDED SPACE AS ILLUSTRATED HERE: YOU MAY FIND MORE RESPONSE SPACES THAN YOU NEED. IF SO, PLEASE LEAVE THEM BLANK.

Multiple choice questions numbered 1 to 114, each with five options A through E.

Item responses continued on reverse side.

3. DATE OF BIRTH

Month, Day, Year grid with numbers 0-9.

4. SOCIAL SECURITY NUMBER (U.S.A. only)

Social Security Number grid with numbers 0-9.

5. REGISTRATION NUMBER (from your admission ticket)

Registration Number grid with numbers 0-9.

6. TITLE CODE (on back cover of your test book)

Title Code grid with numbers 0-9.

7. TEST NAME (on back cover of your test book)

Form code grid with numbers 0-9.

8. TEST BOOK SERIAL NUMBER (upper number in upper right corner of front cover of your test book)

Shaded area for test book serial number.

SHADED AREA FOR ETS USE ONLY

SUBJECT TEST

COMPLETE THE  
CERTIFICATION STATEMENT,  
THEN TURN ANSWER SHEET  
OVER TO SIDE 1.

CERTIFICATION STATEMENT

Please write the following statement below, DO NOT PRINT.  
"I certify that I am the person whose name appears on this answer sheet. I also agree not to disclose the contents of the test I am taking today to anyone."  
Sign and date where indicated.

\_\_\_\_\_

\_\_\_\_\_

\_\_\_\_\_

\_\_\_\_\_

SIGNATURE: \_\_\_\_\_ DATE: \_\_\_\_\_ / \_\_\_\_\_ / \_\_\_\_\_  
Month Day Year

BE SURE EACH MARK IS DARK AND COMPLETELY FILLS THE INTENDED SPACE AS ILLUSTRATED HERE: ●  
YOU MAY FIND MORE RESPONSE SPACES THAN YOU NEED. IF SO, PLEASE LEAVE THEM BLANK.

115	A	B	C	D	E	147	A	B	C	D	E	179	A	B	C	D	E	211	A	B	C	D	E
116	A	B	C	D	E	148	A	B	C	D	E	180	A	B	C	D	E	212	A	B	C	D	E
117	A	B	C	D	E	149	A	B	C	D	E	181	A	B	C	D	E	213	A	B	C	D	E
118	A	B	C	D	E	150	A	B	C	D	E	182	A	B	C	D	E	214	A	B	C	D	E
119	A	B	C	D	E	151	A	B	C	D	E	183	A	B	C	D	E	215	A	B	C	D	E
120	A	B	C	D	E	152	A	B	C	D	E	184	A	B	C	D	E	216	A	B	C	D	E
121	A	B	C	D	E	153	A	B	C	D	E	185	A	B	C	D	E	217	A	B	C	D	E
122	A	B	C	D	E	154	A	B	C	D	E	186	A	B	C	D	E	218	A	B	C	D	E
123	A	B	C	D	E	155	A	B	C	D	E	187	A	B	C	D	E	219	A	B	C	D	E
124	A	B	C	D	E	156	A	B	C	D	E	188	A	B	C	D	E	220	A	B	C	D	E
125	A	B	C	D	E	157	A	B	C	D	E	189	A	B	C	D	E	221	A	B	C	D	E
126	A	B	C	D	E	158	A	B	C	D	E	190	A	B	C	D	E	222	A	B	C	D	E
127	A	B	C	D	E	159	A	B	C	D	E	191	A	B	C	D	E	223	A	B	C	D	E
128	A	B	C	D	E	160	A	B	C	D	E	192	A	B	C	D	E	224	A	B	C	D	E
129	A	B	C	D	E	161	A	B	C	D	E	193	A	B	C	D	E	225	A	B	C	D	E
130	A	B	C	D	E	162	A	B	C	D	E	194	A	B	C	D	E	226	A	B	C	D	E
131	A	B	C	D	E	163	A	B	C	D	E	195	A	B	C	D	E	227	A	B	C	D	E
132	A	B	C	D	E	164	A	B	C	D	E	196	A	B	C	D	E	228	A	B	C	D	E
133	A	B	C	D	E	165	A	B	C	D	E	197	A	B	C	D	E	229	A	B	C	D	E
134	A	B	C	D	E	166	A	B	C	D	E	198	A	B	C	D	E	230	A	B	C	D	E
135	A	B	C	D	E	167	A	B	C	D	E	199	A	B	C	D	E	231	A	B	C	D	E
136	A	B	C	D	E	168	A	B	C	D	E	200	A	B	C	D	E	232	A	B	C	D	E
137	A	B	C	D	E	169	A	B	C	D	E	201	A	B	C	D	E	233	A	B	C	D	E
138	A	B	C	D	E	170	A	B	C	D	E	202	A	B	C	D	E	234	A	B	C	D	E
139	A	B	C	D	E	171	A	B	C	D	E	203	A	B	C	D	E	235	A	B	C	D	E
140	A	B	C	D	E	172	A	B	C	D	E	204	A	B	C	D	E	236	A	B	C	D	E
141	A	B	C	D	E	173	A	B	C	D	E	205	A	B	C	D	E	237	A	B	C	D	E
142	A	B	C	D	E	174	A	B	C	D	E	206	A	B	C	D	E	238	A	B	C	D	E
143	A	B	C	D	E	175	A	B	C	D	E	207	A	B	C	D	E	239	A	B	C	D	E
144	A	B	C	D	E	176	A	B	C	D	E	208	A	B	C	D	E	240	A	B	C	D	E
145	A	B	C	D	E	177	A	B	C	D	E	209	A	B	C	D	E	241	A	B	C	D	E
146	A	B	C	D	E	178	A	B	C	D	E	210	A	B	C	D	E	242	A	B	C	D	E

IF YOU DO NOT WANT THIS ANSWER SHEET TO BE SCORED

If you want to cancel your scores from this administration, complete A and B below. You will not receive scores for this test; however, you will receive confirmation of this cancellation. No record of this test or the cancellation will be sent to the recipients you indicated, and there will be no scores for this test on your GRE file. Once a score is canceled, it cannot be reinstated.

To cancel your scores from this test administration, you must:  
A. fill in both ovals here . . . ○ - ○ B. sign your full name here: \_\_\_\_\_

TR	TW	TFS	TCS	1R	1W	1FS	1CS	2R	2W	2FS	2CS
FOR ETS USE ONLY				3R	3W	3FS	3CS	4R	4W	4FS	4CS
				5R	5W	5FS	5CS	6R	6W	6FS	6CS



00101-007629 • WEBPDF116

727016

