



Deliverable number: D6.4.5

Deliverable title: **BOKU - Advanced Topics and Models**

Delivery date: 2011/07/31 (Extension date: 2011/09/30)

Submission date: 2011/09/30

Leading beneficiary: University of Natural Resources and Life Sciences, Vienna (BOKU)

Status: Version 04 (final)

Dissemination level: PU (public)

Authors: Andreas Zitek
Michael Stelzhammer
Michaela Poppe

Project number: 231526

Project acronym: DynaLearn

Project title: DynaLearn - Engaging and informed tools for learning conceptual system knowledge

Starting date: February 1st, 2009

Duration: 36 Months

Call identifier: FP7-ICT-2007-3

Funding scheme: Collaborative project (STREP)



Abstract

This deliverable (D6.4.5) contains a set of advanced topics and models developed by the University of Natural Resources and Life Sciences, Vienna (BOKU) for Task 6.4. The models are developed in different learning spaces using the latest available prototypes of the DynaLearn (DL) software.

The models are primarily developed to be used within new Master Programme 'Applied Limnology' at BOKU, where DL will be applied for teaching basic and advanced conceptual knowledge on river systems.

For this purpose the idea of a framing 'master-story' capturing and pointing out the dependence of riverine ecosystems from basic universal energetic principles that govern ecosystem processes and functions at different scales was explored.

One focus during the elaboration of advanced topics and models was on the introduction of basic unifying principles of ecosystems like thermodynamics and hierarchy theory.

The other focus was on the development an explicit and advanced model building strategy for an advanced use of the different Learning Spaces. It was tried to find the best way to use the features provided by DL to support model building and to convey environmental systems principles in the most clear conceptual manner.

Suggestions for an advanced use of the different Learning Spaces of the software and with regard to educational settings are given by defining learning goals with regard to the domain and to a generic systems understanding. Finally also the limitations of the advanced models are pointed out.

Internal Review

- Michael Wißner (UAU), Human Centered Multimedia, University of Augsburg.
- Petya Borisova (IBER), Institute of Biodiversity and Ecosystem Research at the Bulgarian Academy of Sciences.

Acknowledgements

The authors would like to thank all WP 6 partners for their work in developing the approach to modelling in the new DynaLearn software. The authors would also like to thank partners from UAU and IBER for undertaking the internal review of this deliverable.

Document History

Version	Modification(s)	Date	Author(s)
01	First draft, concept, structuring	2011-04-23	Michael Stelzhammer
02	Second and final draft for internal review	2011-07-22	Andreas Zitek, Michael Stelzhammer
03	Final document before review	2011-09-25	Andreas Zitek
04	Final document including review	2011-09-30	Andreas Zitek, Michael Stelzhammer, Michaela Poppe

Contents

Abstract	2
Internal Review	2
Acknowledgements	2
Document History	3
Contents	4
1. Introduction	8
2. List of advanced models and topics	9
3. Background Information	10
3.1 Environmental principles presented by the meta-story	10
3.2 Ecosystem theories and model building in DynaLearn	11
3.2.1 Thermodynamics	12
3.2.1.1 The Concept of a 'System'	14
3.2.1.2 The Concept of 'Equilibrium'	15
3.2.1.3 The Concept of a 'Process'	15
3.2.1.4 Quasi-Equilibrium Processes	15
3.2.1.5 The thermodynamic laws	16
3.2.1.6 River morphology and the laws of thermodynamics	17
3.2.1.7 Food webs and the laws of thermodynamics	17
3.2.2 Hierarchy theory	18
3.2.2.1 Background information	18
3.2.2.2 Constructing hierarchy based on the relations between entities	18
3.2.2.3 Definition of scale	19
3.2.2.4 Identification of entities: definitional versus empirical	19
3.2.2.5 Context and constraint	21
3.2.2.6 Nestedness	21
4. Advanced topics and models	23
4.1 River channelization	23

4.1.1	Step 1 – advanced topic summary	23
4.1.2	Step 2 – advanced use of LS 1: creating a semantic and a conceptual causal model	24
4.1.2.1	Learning goals	26
4.1.2.2	Evidence & causality	26
4.1.2.3	Ecosystem properties	27
4.1.2.4	Assumptions and limitations	28
4.1.3	Step 3 - Implementation of an advanced basic causal model at LS 2	28
4.1.3.1	Learning goals	29
4.1.3.2	Assumptions and limitations	30
4.1.4	Step 4: Selection of the most important process(es) - causal differentiation	30
4.1.4.1	Simple sediment balance model	31
	Learning goals	32
	Assumptions and limitations	32
4.1.4.2	Advanced sediment balance model I – influence of river length	32
	Learning goals	35
	Assumptions and limitations	36
4.2	Advanced population models	36
4.2.1	Exponential growth, linear growth and logistic growth	36
4.2.1.1	Learning goals	39
4.2.1.2	Assumptions and limitations	39
4.2.2	Lotka-Volterra model	40
4.2.2.1	Model expression	41
4.2.2.2	Scenarios and simulations	42
4.2.2.3	Learning goals	43
4.2.2.4	Assumptions and limitations	44
4.3	The evolution of the sun	46
4.3.1	Topic summary	46
4.3.1.1	Hertzsprung-Russell Diagram	47
4.3.2	Model expression	48

4.3.2.1	Entity hierarchy	48
4.3.2.2	Model fragment hierarchy	49
4.3.2.3	Model fragments	49
4.3.3	Scenarios and simulations	51
4.3.4	Learning goals	52
4.3.4.1	Content	52
4.3.4.2	Modelling	53
4.3.5	Assumptions and limitations	53
4.4	Evaporation	53
4.4.1	Topic summary	53
4.4.2	Model expression	55
4.4.2.1	Entity hierarchy	55
4.4.2.2	Model fragment hierarchy	55
4.4.2.3	Model fragments	55
4.4.3	Scenarios and simulations	57
4.4.3.1	Sc1 evaporation closed system	57
4.4.3.2	Sc2 evaporation assume heat added	58
4.4.3.3	Sc3 evaporation assume wind	60
4.4.3.4	Sc4 evaporation assume pan size increases	61
4.4.4	Learning goals	63
4.4.4.1	Content	63
4.4.4.2	Modelling	63
4.4.5	Assumptions and limitations	63
5.	Suggestions for the development of a modelling framework	65
6.	Discussion and final conclusions	70
7.	References	72
	Appendix A	76
8.	Introductory master-story about the nature of river systems on Earth	76
8.1	Earth and the solar system	76

8.1.1	The hydrologic cycle and its implications	77
8.1.2	The sun as primary energy source	78
8.1.3	Interaction of light with matter	79
8.1.4	Energy conversion processes as major sources of change	82
8.1.5	The nature of energy	85
8.1.6	The principle of thermal energy (=heat) transfer	85
8.2	Principles of Life on Earth	87
8.2.1	Life, ecosystems and food webs	87
8.2.2	The principle of photosynthesis	89
8.3	Rivers as result of energy conversion processes	89
8.3.1	Adaptation of life to rivers	91
8.3.2	Humans as drivers of change in river systems	91

1. Introduction

Modelling can be considered as a very advanced and complex cognitive process (Jonassen and Strobel, 2006). To minimize unnecessary cognitive load, it makes sense to base model building using DynaLearn (DL) on a generic strategy of model design. Furthermore it makes sense to base models on well-known generic underlying principles in environmental science, that are able to serve as universal link between different phenomena. Characteristics of advanced models in DL therefore have been defined in D6.3 as follows: scientifically valid; insightful in representation; based on clear decisions; justified in the choice and use of the features of different Learning Spaces; use of ecological, social, systems principles; consideration of systemic hierarchy; optimized use of qualitative modelling principles; support for authentic learning; model linkage and connectivity; incorporating a sequencing strategy of models for lessons and courses; integration of models with other resources; identification of recurring patterns in ecology as basis for the development of generic modelling patterns in DL; adequate complexity (Noble et al., 2011). *'Therefore, advanced models, in the context of refined DL curricula, are not just models that cover more complicated concepts but can also be seen as a refinement of models, using the best modelling practice identified here such that they make best use conveying conceptual knowledge'* (Noble et al., 2011).

All this is of high relevance, because not only domain knowledge is incorporated, but also usually an internalization of the whole modelling approach and language may take place, and students may begin to developing mental patterns accordingly (Clariana and Strobel, 2008). A wise use of the modelling language and accompanying principles is therefore crucial for useful and successful learning by modelling. Following the epistemic theory of causality and hierarchy, the teacher is hereby fully responsible for defining the system boundaries, selecting the most important processes and defining the granularity of the model expression in accordance with the learning goals. Granularity hereby can be understood as form of abstraction that affects the complexity of a model referring to the level of resolution and scale of the model (Clariana and Strobel, 2008). Related to this, Box (1976) states about parsimony: *'Since all models are wrong the scientist cannot obtain a 'correct' one by excessive elaboration. On the contrary following William of Occam he should seek an economical description of natural phenomena. Just as the ability to devise simple but evocative models is the signature of the great scientist so overelaboration and overparameterization is often the mark of mediocrity'*.

Any advanced model should therefore be judged for its ability to capture complex principles causally and conceptually in the most insightful way (Ockham's razor design, pattern oriented modelling and medium zone of complexity) taking into account the potential transfer of generic (re-usable) modelling patterns provided by DL. Besides that it makes sense, to provide an active, interesting and involving framework for the lectures, in which the modelling activity is embedded as social activity with clear targets, as meaningful learning occurs *'when learners are active, constructive, intentional, cooperative and working on authentic tasks'* (Jonassen and Strobel, 2006).

Advanced models from this perspective are therefore characterized by 1) providing a scientifically valid representation of an environmental issue, 2) providing powerful, insightful, clear and transferable representations of important environmental processes, 3) making advanced and intentional use of the features available at different Learning Spaces of DL for creating insightful representations of environmental systems at an adequate level of complexity 4) by clearly defined and interesting learning goals linked to a curriculum supporting authentic and engaging learning.

Summarizing, probably the most advanced model is one that supports individual learning and understanding of a specific complex environmental problem best by providing transferable modelling and systems patterns given the specific modelling language provided by DL.

Instead of producing just more models, the focus of this deliverable is clearly on making advanced use of the features of DL to produce powerful and insightful representations of real world phenomena introducing basic underlying ecosystem principles. The attempt is, not to include excessive detail into models but finding and transferring a powerful viewpoint using generic and re-applicable modelling and system patterns.

This deliverable is organized as follows: In the next section (Section 2), an overview of the topics and models are described. Sections 3 contains background information with regard to the development and content of a framing master-story (the master-story itself can be found in Appendix A), and the ecosystem principles (systems approach, hierarchy theory, thermodynamics) that were introduced along with an advanced model building strategy. Section 4 contains the advanced models constructed in different Learning spaces. Suggestions for the development of an advanced model building strategy are presented in section 5, and a discussion and final conclusions are presented in Section 6. Section 7 contains the references, and section 8 is Appendix A containing the master-story.

2. List of advanced models and topics

Together with the advanced topics and models presented here, we aimed also at developing an advanced model building strategy as inherent content of any advanced model. As this strategy is linked to an advanced use of the different Learning Spaces, we include models designed in different Learning Spaces here. In total 8 models (with 3 of them being LS 6 models) were developed following an explicit modelling strategy. Hereby the focus was on the development and application of generic and re-usable modelling patterns and the integration of unifying principles in ecology like thermodynamics and hierarchy theory (Tab. 1).

Table 1: Summary of themes and topics assigned to BOKU in from the D6.1 curricula in Environmental Sciences and the advanced topics and models covered in BOKU D6.4.5 including the development of an advanced use of the Learning Spaces.

Theme	Topic	Subtopic	Learning space	Explanation
ESR & LWU	Natural processes forming riverine landscapes and habitats Flood protection	Exploration of different aspects of river channelization in relation to a thermodynamic view and hierarchy theory on different Learning Spaces with the aim of defining an advanced model building strategy when progressing through different Learning Spaces	LS 1	Use of LS1 to create a conceptual semantic model
			LS 1	Advanced use of LS1 to create a causal model combined with an initial entity definition and hierarchy structure (which is finally needed at LS2)
			LS 2	Implementation of a basic causal model based on the LS1 model, entity hierarchy, definitional versus empirical entities
			LS 4	Selection of the most important processes and implementation of a causal differentiation model, development of a generic model structure with feedback loops
LW	Populations	Exponential growth, linear growth and logistic growth of populations	LS 4	Introduction of a generic model structure with feedback loops, comparison of mathematical and conceptual models
		Lotka-Volterra model	LS 6	Generic population model structure with interactions between populations, comparison of the mathematical and conceptual model
ESR	Natural processes forming riverine landscapes and habitats	Sun development cycle	LS 6	Temporal evolution of entities characterized by different processes using conditional statements
		Evaporation	LS 6	Exploration of different factors causing and influencing evaporation as main element of the hydrological cycle; modelling of a dynamic equilibrium (equilibrium vapour pressure) occurring in a closed system

3. Background Information

The models developed here are intended to be used within the new Master Programme 'Applied Limnology' at BOKU, where DL will be applied for teaching basic and advanced conceptual knowledge on river systems. We think that for an advanced use of DL it is necessary to develop a modelling strategy that leads to a clear and insightful representations and transferable modelling patterns.

From a curriculum point of view, a 'master-story' is developed to introduce a generic systems perspective on planet Earth (Appendix A). Master stories can be defined as stories '*able to provide a comprehensive framework to explain all that exists and occurs*' (Irving and Klenke, 2004). The story includes major environmental system elements and processes and aims at pointing out the inherent existence of these processes in everyday's experiences. The idea behind an interesting master-story is also to promote environmental science as means for a better understanding of the world and the cosmos around us. It should trigger the interest of the students to go into more detail with certain environmental issues and learn more according to their own interest. However, as the master-story developed was meant to initially capture and link the main ideas and relevant processes that create change on Earth, it is mainly based on educational and scientific internet resources. To be used within a curriculum it is recommended to base the story primarily on primary literature. This was not completely possible with the given resources.

As all things in the universe are linked to each other, discovering environmental issues from the viewpoint of unifying principles is thought to provide a highly effective and engaging way of teaching and learning. Once the fundamental relationships have been explored causally and conceptually, mathematical functions can be used with much more understanding and intention.

In our example, fundamental processes relevant for a deeper understanding on the nature of rivers on earth and their associated biological elements are explored. For this purpose, energy transformation as the basic principle of any change in the universe is introduced and hierarchy theory is presented as tool for structuring environmental perception and developing models according to the interaction of entities at and across different scales. In principle this story applies to a wide range of environmental issues.

3.1 Environmental principles presented by the meta-story

Important principles that can be extracted from this master-story (Appendix A) on rivers on earth are:

- The solar system and the uniqueness of Earth
- Energy creation and provision by the sun
- Interaction of light with matter
- Energy conversion processes
- Heat and energy transport
- Hydrologic cycle
 - Evaporation
 - Latent energy
 - Precipitation
 - Condensation
 - Latent energy release
 - Convection
 - Atmospheric circulation and local weather (wind and hydrological cycle)

- Hurricane formation
- Effects of global change
- Different types of energy
 - Kinetic Energy (movement of wind and water, ocean currents)
 - Gravitational Potential Energy (falling rain gains kinetic energy from its gravitational potential, water flowing down from mountains)
 - Thermal Energy (input from the sun, radioactive decay, molten rocks). Transmitted by conduction, convection, radiation
 - Chemical Energy (holds together atoms in molecules, the energy of the chemical bond)
 - Nuclear Energy (released during radioactive decay)
- Forms created by natural processes powered mainly by sun energy and gravitational forces
- Climate and geomorphic setting as major agents creating river forms
- Equilibrium processes (erosion-deposition)
- Principles of sustaining Life on Earth
- Photosynthesis
- Ecosystem creation
- Energy flow through abiotic and biotic (living) systems
- Biological entities (species, populations) sustained by these processes and forms
- Interaction between biological entities (predator-prey)
- Rivers as result of energy conversion processes
- Human actions disturbing natural processes
- Human need for restoring these natural processes

Principles that are considered to be relevant for any environmental modelling activity:

- Systems theory
- Thermodynamics
- Hierarchy theory

3.2 Ecosystem theories and model building in DynaLearn

It is obvious, that a **systems approach** is needed to tackle the problem of environmental issues adequately. In general a system consists of elements, interconnections and a function or purpose not inherent in its singular parts (Meadows, 2008). A systems approach is therefore characterized by viewing a problem as an interconnected set of entities with related characteristics; causal relations and loops are used to explain the system, its behaviour and stability (Meadows, 2008; Simon, 2008). Stocks (or quantities) as main elements one can see, feel, count, or measure, are the foundation of a system (Meadows, 2008). *'A system stock is just what it sounds like: a store, a quantity, an accumulation of material or information that has built up over time. It may be water in a bathtub, a population, the wood in a tree, the money in a bank, your own self confidence. Stocks change over time through the actions of flow. Examples of flows are filling, draining, births, deaths, purchases and sales, growth, decay, deposits and withdrawals, successes and failures. A stock is then the present memory of the history of changing flows within a system'* (Meadows, 2008).

A problem can be considered as complex, when an explanation of its behaviour requires several different levels to be considered simultaneously (Ahl and Allen, 1996). Unravelling complexity therefore involves identifying entities, relations, structures, state variables and processes being active at different scales and relating them adequately.

Thermodynamics as the study of energy, the conversion of energy between various forms and the ability of energy to do work provides a generic framework to be used to explain and causally link many processes going on in the environment. As such it is extensively applied in ecology (Nielsen, 2000; Svirezhev, 2000; Tiezzi, 2011) and suggested as one of the main guiding principles for a new ecology systems perspective (Jørgensen et al., 2007). It has also been applied to the explanation of food web structures (Meysman and Bruers, 2007), resource use and sustainability (Hammond; Rosen and Dincer, 2001), economics (Annala and Salthe, 2009; Daly and Farley, 2003), to holistic landscape ecology (Li, 2000), geomorphology (Huggett, 2007) and the formation of river systems (Leopold and Langbein, 1962). **Thermodynamic principles therefore can provide a unifying ground floor for learning and understanding the environment.**

Furthermore **hierarchy theory** introduces the notion of scale and strongly directs our perception to environmental elements such as entities (Ahl and Allen, 1996; Allen, 1992; O'Neill et al., 1986).

Following Ahl and Allen (1996), the world is populated by entities ('holons') at different spatial and temporal levels. They can interact within one hierarchical level or, with some restrictions, across hierarchical levels. But how to identify entities, and the way they interact? One can use the definition of surfaces, which are often concrete parts of experience, to structure observation into relevant sub-units or entities. Surfaces as borders of entities allow via filters matter, energy, or information pass through themselves in characteristic rates. These boundaries might not be identifiable as clearly visible boundary in space; they also can be identified by their function in affecting rates of exchange. Therefore parts of a system can be easily separated from each other when they have clearly identifiable surfaces or filters that obviously influence the exchange of information or signals.

Size and (temporal) behaviour of an entity/organism can also be used to identify to which scale or hierarchical level it belongs. In addition, so called nested hierarchies are those characterised by a containment of the lower levels by upper levels. Non-nested hierarchies in contrast apply a single criterion from top to bottom, units of measurement might apply to all levels; this structure allows for more flexibility in ordering the system elements. In general, the ordering principle should be chosen for reasons of clarity of expression (Ahl and Allen, 2006).

The observer is hereby fully responsible to recognize the boundaries around entities, developing definitional criteria and linking them at the appropriate spatial scale and finally attach the changing quantitative system states of interest to them.

Following Ahl and Allen (1986) entities could be definitional or empirical. This means, that we might think that something represents an entity at the beginning, while later we will treat this element as quantity of another entity. The entities should hereby be defined in a way to maximise clarity of model structure.

Hierarchy theory therefore delivers a powerful means for defining entities and setting them into relation considering their spatial and temporal scale, grain and extent.

3.2.1 Thermodynamics

'Thermodynamics is a branch of physics which deals with the energy and work of a system. It was born in the 19th century as scientists were first discovering how to build and operate steam engines. Thermodynamics deals only with the large scale response of a system which we can observe and measure in experiments. Small scale gas interactions are described by the kinetic theory of gases. The methods

complement each other; some principles are more easily understood in terms of thermodynamics and some principles are more easily explained by kinetic theory¹.

Thermodynamics is the study of energy. Energy is the ability to bring about change or to do work. Energy exists in many forms, such as heat, light, chemical energy, and electrical energy' (Farabee, 2007). Accordingly all changes in the world can be seen as being related to thermodynamics.

E.g. also diffusion, the '*spread of particles through random motion from regions of higher concentration to regions of lower concentration*² leading to a regular distribution of particles and the complete mixture of two or more substances, follows the principle of conduction according to the second law of thermodynamics; it is irreversible (without any other influence) and reducing the gradient with increasing the entropy.³

If an uneven distribution of particles exists, statistically more particles from the higher concentration move to the region of lower concentration. The movement hereby depends on the self propelled movement of molecules, atoms or ions caused by their inner thermic energy. In closed systems diffusion leads to a complete reduction of concentration differences and a complete mixture, which sets the net transfer of mass between the regions to zero. At larger scales in liquids and gases mass transport by convection is dominating. Diffusion of fluid through a semipermeable membrane from a solution with a low solute concentration (high chemical potential) to a solution with a higher solute concentration (low chemical potential) until there is an equal concentration of fluid on both sides of the membrane is called osmosis.⁴ In biology osmosis is the result of diffusion of water across a semi-permeable membrane. If the medium surrounding the cell has a higher water concentration than the cell, then the cell will gain water by osmosis.

According to thermodynamics any change in the world occurs because of levelling of energetic gradients or energy conversion processes; without constant energy provision by the sun, entropy as a measure of disorder on earth would constantly increase (Kondepudi and Prigogine, 1998).

The following information in the box was compiled from different internet sources for teaching and learning about energy and thermodynamics.^{5, 6}

Kinetic energy

Kinetic energy is motion—of waves, electrons, atoms, molecules, substances, and objects.

Kinetic energy can appear in many forms.

- Radiant energy is kinetic energy is electromagnetic energy that travels in transverse waves. Radiant energy includes visible light, x-rays, gamma rays and radio waves. Light is one type of radiant energy. Solar energy is an example of radiant energy.
- Thermal energy or heat, is the internal energy in substances—the vibration and movement of the atoms and molecules within substances. Geothermal energy is an example of thermal energy.
- Electrical energy is the movement of electrical charges. Everything is made of tiny particles called atoms. Atoms are made of even smaller particles called electrons, protons, and neutrons. Applying a force can

¹ <http://www.grc.nasa.gov/WWW/K-12/airplane/thermo.html>

² http://en.wikipedia.org/wiki/Diffusion#cite_note-Carslaw-1

³ http://de.wikipedia.org/wiki/Diffusion#cite_note-Carslaw-1

⁴ <http://de.wikipedia.org/wiki/Osmose>

⁵ http://www.eia.gov/kids/energy.cfm?page=about_forms_of_energy-basics

⁶ <http://www.lessonsnips.com/docs/pdf/kineticpotential.pdf>

make some of the electrons move. Electrical charges moving through a wire is called electricity. Lightning is another example of electrical force

- Sound is also kinetic energy. It is created when a force causes an object or other matter to vibrate. We hear sound because force causes our eardrums to move.
- Motion energy is the simplest form of kinetic energy. It comes from the movement of matter from one place to another. Water flowing, waves in the ocean and wind are examples of motion energy. Objects and substances move when a force is applied according to Newton's Laws of Motion.

Potential Energy

The other category of energy is potential energy. Potential energy has the ability to become kinetic energy. Potential energy is stored energy that will possibly become energy in motion. It is also the "energy of position," which means that an object's power comes from gravity. Potential energy also appears in several forms.

- Gravitational energy comes from the potential power gravity can have on the object. Before he jumps from a plane, a skydiver has a great deal of stored, gravitational energy. He has more gravitational energy than a bungee jumper, because he is much higher.
- Chemical energy is stored inside of atoms and molecules. These tiny particles are held together with bonds that have stored or "chemical" energy. Biomass, petroleum, natural gas, and propane are examples of stored chemical energy.
- Stored mechanical energy is energy that is stored in an object before a force causes it to move. For example, when a rubber band is stretched, it has stored mechanical energy, or the potential to be in an object in motion. A compressed spring is another example for stored mechanical energy.
- Nuclear Energy is energy stored in the nucleus of an atom—the energy that holds the nucleus together. The energy can be released when the nuclei are combined or split apart. This potential energy becomes one of the most powerful forces in the universe. Nuclear power plants split the nuclei of uranium atoms in a process called fission. The sun combines the nuclei of hydrogen atoms in a process called fusion. Scientists are working on creating fusion energy on earth, so that someday there might be fusion power plants.

3.2.1.1 The Concept of a 'System'

'A thermodynamic system is a quantity of matter of fixed identity, around which we can draw a boundary (Fig. 1). The boundaries may be fixed or moveable. Work or heat can be transferred across the system boundary. Everything outside the boundary is the surroundings. When working with devices such as engines it is often useful to define the system to be an identifiable volume with flow in and out.

A closed system is a special class of system with boundaries that matter cannot cross. Hence the principle of the conservation of mass is automatically satisfied whenever we employ a closed system analysis. This type of system is sometimes termed a control mass.

The thermodynamic state of a system is defined by specifying values of a set of measurable properties sufficient to determine all other properties. For fluid systems, typical properties are pressure, volume and temperature. More complex systems may require the specification of more unusual properties. As an example, the state of an electric battery requires the specification of the amount of electric charge it contains' (Greitzer et al., 2007).

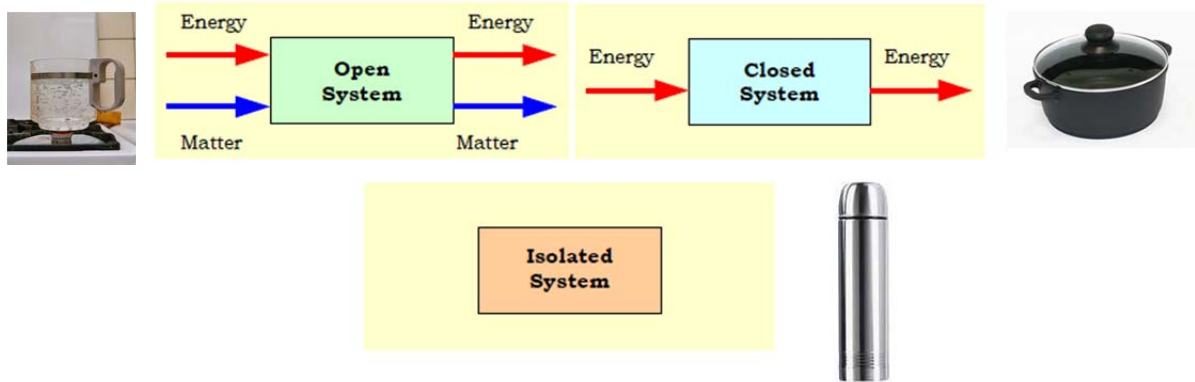

Figure 1: Defined after Prigogine (1967).

3.2.1.2 The Concept of 'Equilibrium'

The state of a system in which properties have definite, unchanged values as long as external conditions are unchanged is called an equilibrium state.

A system in thermodynamic equilibrium satisfies:

- mechanical equilibrium (no unbalanced forces)
- thermal equilibrium (no temperature differences)
- chemical equilibrium' (Greitzer et al., 2007).

3.2.1.3 The Concept of a 'Process'

If the state of a system changes, then it is undergoing a process. The succession of states through which the system passes defines the path of the process. If, at the end of the process, the properties have returned to their original values, the system has undergone a cyclic process or a cycle. Note that even if a system has returned to its original state and completed a cycle, the state of the surroundings may have changed' (Greitzer et al., 2007).

3.2.1.4 Quasi-Equilibrium Processes

We are often interested in charting thermodynamic processes between states on thermodynamic coordinates. Properties define a state only when a system is in equilibrium. If a process involves finite, unbalanced forces, the system can pass through non-equilibrium states, which we cannot treat. An extremely useful idealization, however, is that only 'infinitesimal' unbalanced forces exist, so that the process can be viewed as taking place in a series of 'quasi-equilibrium' states. (The term quasi can be taken to mean 'as if' you will see it used in a number of contexts such as quasi-one-dimensional, quasi-steady, etc.). For this to be true the process must be slow in relation to the time needed for the system to come to equilibrium internally. For a gas at conditions of interest to us, a given molecule can undergo roughly molecular collisions per second, so that, if ten collisions are needed to come to equilibrium, the equilibration time is on the order of seconds. This is generally much shorter than the time scales associated with the bulk properties of the flow (say the time needed for a fluid particle to move some significant fraction of the length of the device of interest). Over a large range of parameters, therefore, it is a very good approximation to view the thermodynamic processes as consisting of such a succession of equilibrium states, which we can chart' (Greitzer et al., 2007). **This is similar to how system states are represented in DynaLearn.**

3.2.1.5 The thermodynamic laws

There are three principal laws of thermodynamics. Each law leads to the definition of thermodynamic properties which help us to understand and predict the operation of a physical system. Unfortunately, the numbering system for the three laws of thermodynamics is a bit confusing. We begin with the zeroth law.

The zeroth law of thermodynamics involves some simple definitions of thermodynamic equilibrium. Thermodynamic equilibrium leads to the large scale definition of temperature, as opposed to the small scale definition related to the kinetic energy of the molecules.

The first law of thermodynamics relates the various forms of kinetic and potential energy in a system to the work which a system can perform and to the transfer of heat. This law is sometimes taken as the definition of internal energy, and introduces an additional state variable, enthalpy. The first law of thermodynamics allows for many possible states of a system to exist. But experience indicates that only certain states occur.

This leads to the second law of thermodynamics and the definition of another state variable called entropy. The second law stipulates that the total entropy of a system plus its environment can not decrease; it can remain constant for a reversible process but must always increase for an irreversible process⁷.

The third law of thermodynamics states that it is impossible to cool a system to exactly absolute zero⁸.

The Zeroth law of thermodynamics

'A thermodynamic system is said to be in equilibrium when the thermodynamic parameters describing its state cease to change in time. A system is said to be in thermal equilibrium with another system when it is diathermically connected to the other system, (i.e. the transfer of heat is allowed between the systems) and its thermodynamic parameters cease to change in time. The zeroth law of thermodynamics may be stated as follows:

- *If two systems are in thermal equilibrium with a third, they are in thermal equilibrium with each other.⁹*

First Law of Thermodynamics

'Energy can be changed from one form to another, but it cannot be created or destroyed. The total amount of energy and matter in the Universe remains constant, merely changing from one form to another. The First Law of Thermodynamics (Conservation) states that energy is always conserved, it cannot be created or destroyed. In essence, energy can be converted from one form into another' (Farabee, 2007). Strictly speaking the common use of the terms energy production and energy consumption is therefore scientifically wrong, and one should consider using the term energy conversion.

The Second Law of Thermodynamics

The second law of thermodynamics distinguishes between reversible and irreversible physical processes. It tells how this shows the existence of a mathematical quantity called the entropy of a system, and thus it expresses the

⁷ <http://www.grc.nasa.gov/WWW/K-12/airplane/thermo.html>

⁸ http://en.wikipedia.org/wiki/Laws_of_thermodynamics

⁹ http://en.wikipedia.org/wiki/Laws_of_thermodynamics

irreversibility of actual physical processes by the statement that the entropy of an isolated macroscopic system never decreases. Equivalently, perpetual motion machines of the second kind are impossible'.¹⁰

The second law of thermodynamics states that "in all energy exchanges, if no energy enters or leaves the system, the potential energy of the state will always be less than that of the initial state." This is also commonly referred to as entropy. A watchspring-driven watch will run until the potential energy in the spring is converted, and not again until energy is reapplied to the spring to rewind it. A car that has run out of gas will not run again until you walk 10 miles to a gas station and refuel the car. Once the potential energy locked in carbohydrates is converted into kinetic energy (energy in use or motion), the organism will get no more until energy is input again. In the process of energy transfer, some energy will dissipate as heat. Entropy is a measure of disorder: cells are NOT disordered and so have low entropy. The flow of energy maintains order and life. Entropy wins when organisms cease to take in energy and die' (Farabee, 2007).

The third law of thermodynamics

The third law of thermodynamics concerns the entropy of a perfect crystal at absolute zero temperature, and implies that it is impossible to cool a system to exactly absolute zero'.¹¹

3.2.1.6 River morphology and the laws of thermodynamics

Rivers are typical examples for open thermodynamic ecosystems (Jørgensen et al., 2007), deriving most of its energy and matter by the hydrological and geomorphological processes.

'Rivers are natural 'machines', consuming energy to do work as they act in concert with other geomorphic agents to erode landscapes and transport the resulting detritus. Indeed, Ferguson (1981) described them as being like a conveyor belt, moving sediment intermittently towards base level. Because they convey highly variable amounts of water and sediment over time and space, they are often elusive in revealing clear patterns of behaviour. However, empirical studies over more than a century have shown that collectively alluvial rivers exhibit surprisingly uniform average characteristics (Leopold and Maddock, 1953). Across the globe they are subject to different climates, biomes, topographies, lithologies and geological structures, so why is it that they do not vary spatially or temporarily more than they do? Channel hydraulics appears to be governed by a relatively simple unifying principle. This study focuses on alluvial rivers with uniform mobile boundaries but later considers alluvial rivers with non-uniform boundaries, where exogenous (externally imposed) factors play a vital role in achieving a stable equilibrium state. Those variables most immediate to the operation of an alluvial river as a mechanical system are water discharge, channel gradient, sediment load and sediment calibre. The first of these is a largely independent variable and the remaining three are less so. The first two determine the system's operational energy (power) and the second two determine the work it must do. Consequently, rivers are often the product of a balance, and sometimes an imbalance, between work achieved and energy consumed. For this reason a first approximation of a river's form and behaviour can be made from an analysis of its overall operational mechanics' (Nanson and Huang, 2008).

3.2.1.7 Food webs and the laws of thermodynamics

'Energy transfers within food webs are governed by the first and second laws of thermodynamics. The first law relates to quantities of energy. It states that energy can be transformed from one form to another, but it cannot be

¹⁰ http://en.wikipedia.org/wiki/Laws_of_thermodynamics

¹¹ http://en.wikipedia.org/wiki/Laws_of_thermodynamics

created or destroyed. This law suggests that all energy transfers, gains, and losses within a food web can be accounted for in an energy budget.

The second law relates to the quality of energy. This law states that whenever energy is transformed, some of it must be degraded into a less useful form. In ecosystems, the biggest losses occur as respiration. The second law explains why energy transfers are never 100% efficient. In fact, ecological efficiency, which is the amount of energy transferred from one trophic level to the next, ranges from 5-30%. On average, ecological efficiency is only about 10%.

Because ecological efficiency is so low, each trophic level has a successively smaller energy pool from which it can withdraw energy. This is why food webs have no more than four to five trophic levels. Beyond that, there is not enough energy to sustain higher-order predators'.¹²

3.2.2 Hierarchy theory

The majority of the text passages of the following section have been taken more or less literally from the book 'Hierarchy theory: a vision, vocabulary, and epistemology' written by Ahl and Allen (1996)

3.2.2.1 Background information

'Experience is always interpreted by cognitive models, which operate at the boundary between external and internal world. Meaningful experience is therefore interpreted (sensationally experienced) behaviour of observed changes related to entities. The point is to link the world of internal models (containing representations of the entities and their related properties and the suggested cause of change) to the external flux.

Useful definitions of entities, their properties and their dynamics are those that correlate with repeated patterns in the observed. Only through models, data can be used to say what will happen again and why, before subsequent measurements are made. Data alone predict nothing.

3.2.2.2 Constructing hierarchy based on the relations between entities

A system can be described as hierarchical when it can be described as composed of observable sub-units unified by super ordinate relations. Different levels in an empirical hierarchy are populated by entities that differ in size and frequency characters. Size and behaviour of an entity/organism determines to which scale or hierarchical level it belongs (Fig. 2).

Therefore in a hierarchy of empirical levels of observation, levels are ordered according to the spatial and frequency characteristics of the entities that occupy each level. Once hierarchy levels are ordered (be flexible in ordering), the next issue is to look at the functional interrelationships between levels.

Figure 2: Relationship between body size and the life span of different organisms in the sea (after Steele, 1992), each of these different organisms correspond to a different hierarchical level.¹³

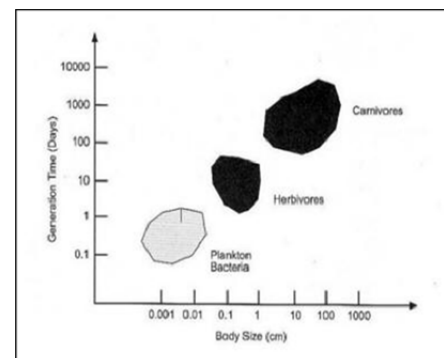

¹² <http://science.jrank.org/pages/2507/Energy-Transfer-laws-thermodynamics-energy-transfer-in-food-webs.html>

¹³ http://openlandscapes.zalf.de/openlandscapeswiki_glossaries/Ecosystem%20Theories%20-%20The%20Hierarchy%20Theory%20in%20Ecology.aspx

3.2.2.3 Definition of scale

To construct that model of our environment, the observer has to decide which entities are useful and at which scale he wants to observe the world. Measurement scale sets limits on the scope of what can be seen, or captured in an observation – if the mesh of our net is too big, we will not capture the small fish. There are limits to the smallest (grain) and largest entities (extent) that may be captured. Grain and extent fix the scale of experience. Scale may be spatial temporal or both. So before starting to define entities, the scope of the observation has to be established which also requires the establishment of spatial and temporal limits. Usually a wide extent and a fine grain are needed to observe complex phenomena, and this combination is very difficult to achieve.

Dynamics are rate-dependent and structure is rate independent. Forging a link between scale and structure is the heart of hierarchy theory, and in principle of any dynamic systems model.

3.2.2.4 Identification of entities: definitional versus empirical

To identify the relevant elements of a system we want to study, it makes sense freeze part of the flux by giving definitions to repeated patterns of experiences involving the main properties of the system that we are interested in.

We can start this with definitional criteria/entities (postulated before a measurement/observation is made) and empirical criteria/entities (the criteria found after the measurement/observation). Armed with definitional entities postulated in a question and a measurement protocol of fixed scale, empirical entities are discovered in the process of observing.

The distinction between definitional and empirical entities is important, as often the contribution of the observer to the observed is forgotten, taking the definitional criteria for real. We have never access to the world but learn in interaction with it. Knowledge is constructed from our interaction with the observed. Under constructivism, the things that emerge from interaction are a product of interaction, not some prior existence of things. A different interaction would produce a different set of things (riverine landscapes versus local 3D models).

Definitions and criteria/entities are not discovered in nature; instead they are product of the observer and his/her interpretation of perception. These criteria and patterns give structure to experience and are modified to facilitate assimilating new experiences into existing cognitive models (the observer's web of belief). Scientific understanding can be seen as socially accepted patterns of perception.

In absence of cognitive models, external dynamic processes possess no structure and meaning for the observer. Chance favours the prepared eye: in order to make an observation one must have an idea of what can be seen, and a framework of beliefs into which the observations (both, confirming and disconfirming) can be integrated.

Thus observation is the interface between perception and learning, and learning by modeling is preparing the eye. Prior learning is invoked to structure new information/perception, and new information/perceptions are used to advance learning in a constructivist manner. This makes us more effective in interpreting the world around us. The interrelation between observation, perception and learning is the focus of hierarchy theory.

In principle the different spatial and temporal levels of the world are populated by entities, and their relations. Entities could interact within one level or, with some restrictions, across hierarchical levels. But how to identify entities, and the way they interact? To 'freeze' parts of the system was already described as a means to get access to the main elements of a system, but still help is needed to define the entities under study.

Following the hierarchy theory, one can use the definition of surfaces to structure observation into relevant sub-units or entities. The nice thing is, that surfaces are usually a concrete part of experience. Surfaces allow matter,

energy, or information pass through themselves in characteristic rates. Surfaces are the places where the filters are usually active. The filter is responsible for the rate, the surface correlates with the boundary of the observed empirical entity (example of the border of a country, where information exchange is delayed, making it definable as entity). But not necessarily the boundaries need not be identifiable as tangible boundary in space, but can function entirely on different rates of exchange within the abstractly bound entity compared to the rates of exchange with the surrounding entity (social clusters). Therefore it is helpful to look at parts of a system having surfaces acting as filter to identify entities.

Filters could 1) attenuate a signal, 2) delay a signal or 3) integrate or average signals (like photosynthesis and respiration is transferred to a tree as overall difference) (Fig. 3). Filters associated with higher levels of organization integrate information over a longer period of time, or wider spatial expanse, than do lower levels. Entities belonging to high levels have low-frequency pass filters. Those belonging to low levels have high frequency pass filters. Filters in the material system play a major role in what we see, as our experience of empirical entities is restricted to the material or information flowing through their filters. Regular structure and hierarchical order emerge from differential rates of energy, matter and information flow at the interface between the observer and the observed.

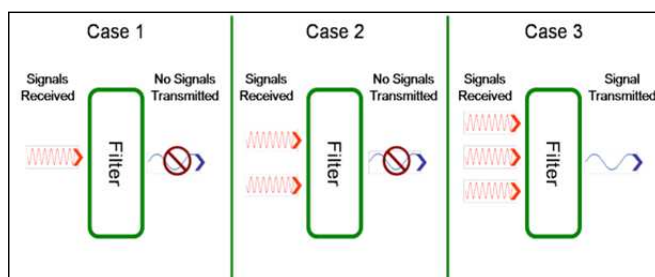

Figure 3: Three different cases where the same filter reacts only when the signals received reach certain condition, in this case: the signals received should be at least 3x for the filter to emit a single signal.¹⁴

Surfaces can be also passed by **information channels**; they are the opposite as surfaces.

Communication channels to the outside are the means whereby an entity becomes part of a larger system whereas surfaces define the entity at its own level.

So one can also think of relations of entities at different levels in term of different rates of flow (and not only in size and/or frequency of behaviour) exchanged through their surfaces.

Capturing the relationships between the whole, its parts below and context above, is one goal of hierarchy analysis.

Entities as parts of the system are defined as **holons** in hierarchy theory. Holons are the parts that make the whole. For the parts to experience the outside, the surfaces must be penetrated by signal. By passing the surface inside or outside, the signal is usually filtered and modified.

The observer is responsible to recognize the boundaries around entities, erecting definitional criteria for entities, recognizing phenomena, linking the entities and finally building models. The scientist works ever on an expansion of his web of belief by learning continuously structure his/her experience by identifying entities and their hierarchical linkages and interactions.

Levels are not linked by push-and pull Newtonian mechanics. They are related by what is possible from below, and allowed from above. Contexts, constraint, filters, response rates, characteristic frequency and sizes all link levels, and generate surfaces that isolate entities within levels.

¹⁴http://openlandscapes.zalf.de/openlandscapeswiki_glossaries/Ecosystem%20Theories%20-%20The%20Hierarchy%20Theory%20in%20Ecology.aspx

3.2.2.5 Context and constraint

Context is defined as that which is constant when the system exhibits behaviour (e.g. slope, valley width and a given landscape the limits processes like sediment and transport). What in general defines a level as higher, is that it serves a context for the lower level entities. Higher levels might put a constraint on the lower levels. By being unresponsive higher levels constrain and thereby impose general limits to the behaviour of lower level entities (Fig. 4).

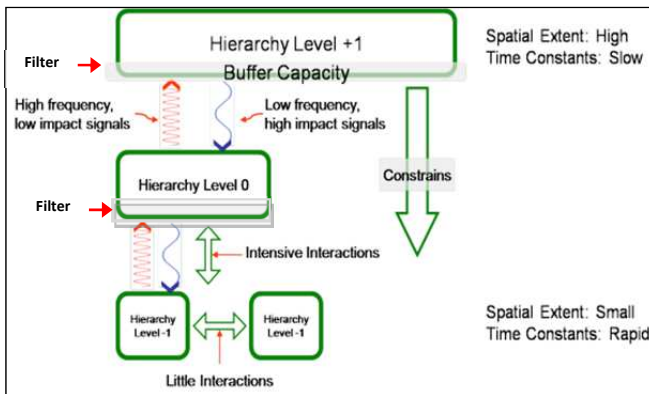

Figure 4: Adopted diagram showing the frequency of the signal transmission from below to top and vice versa along the different hierarchy levels.¹⁵

3.2.2.6 Nestedness

In non-nested systems the general ordering principles can be seen in terms of four characteristics of upper levels relative to lower levels. Upper level entities 1) behave at relatively low frequencies, 2) behave with less integrity, 3) offer context and 4) constrain lower entities (Fig. 4).

Nested hierarchies are those with the added requirement of containment of lower levels by upper levels. Non-nested hierarchies apply a single criterion from top to bottom, units of measurement apply to all levels and allow more flexibility in ordering. The ordering principle is chosen for reasons of clarity of expression' (Fig. 5 and Fig. 6).

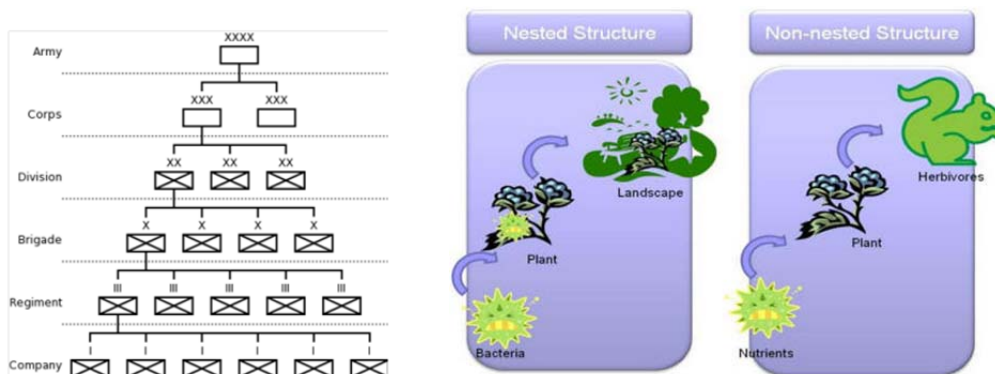

Figure 5: Typical nested unit hierarchy structure (left); Figure 6 (right): Comparison between a nested and a non-nested structure. In a nested structure on the left, the bacteria live on the plant and the plant in the landscape, they don't cease to exist as the form part of the superior hierarchical level. In the non-nested structure on the right hand side, the plant ceases to exist when the rabbit eats it.¹⁶

¹⁵ http://openlandscapes.zalf.de/openlandscapeswiki_glossaries/Ecosystem%20Theories%20-%20The%20Hierarchy%20Theory%20in%20Ecology.aspx

¹⁶ http://openlandscapes.zalf.de/openlandscapeswiki_glossaries/Ecosystem%20Theories%20-%20The%20Hierarchy%20Theory%20in%20Ecology.aspx

Rivers are typical examples for hierarchically nested, open and thermodynamically driven ecosystems (Jørgensen et al., 2007) (Fig. 7).

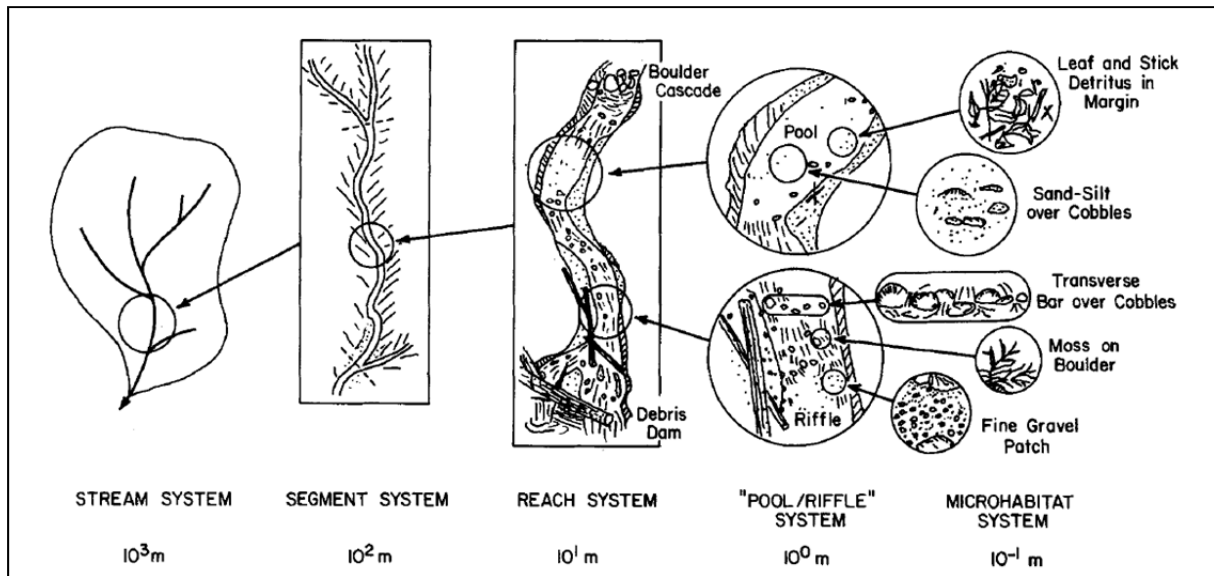

Figure 7: The idea of the hierarchical organization of a stream system and its habitat subsystems; approximate linear spatial scale, appropriate to second- or third-order mountain stream, is indicated (Frissell et al., 1986).

4. Advanced topics and models

4.1 River channelization

4.1.1 Step 1 – advanced topic summary

As important part of any model building activity a **topic summary**, preferably **based on primary scientific literature**, should be produced. Due to limited resources this will not always be possible. Here we start with the example of the effect of river channelization on physical and biological features of river systems. It is also helpful to accompany the text with some insightful figures highlighting the general system structure.

Channelization can be described as a process that includes ‘all processes of river engineering for the purposes of flood control, drainage improvement, maintenance of navigation, reduction of bank erosion or relocation for highway construction’ (Brookes, 1988). According to Brookes (1988), channelization historically was extensively applied to increase arable land by reducing flooding and draining land. From the different methods associated with the term ‘river channelization’ described by Brookes (1988) (widening, deepening, straightening, levee construction, bank stabilization, clearing and snagging) we are going to deal mainly with river straightening (or realigning, which is the British term), where an increase of velocity is targeted via an increase of slope, which is achieved by shortening the river channel; water transport therefore takes place faster. In many cases, bank stabilization, another channelization technique, is applied to the straightened proportion of the river.

The physical effects of shortening the river is an increase in slope, flow velocity, increased stream power with an associated increase of sediment transport, which is followed by a river bed degradation (Brookes, 1988). The increased sediment transport out of the channelized reach leads to river bed degradation and a subsequent loss of gravel banks and the associated habitat diversity. This is known to negatively affect fish, macrozoobenthos, birds, and even mammals (Brookes, 1988; Jungwirth et al., 1993) and water quality (Shields et al., 2010).

The increased sediment transport capacity of the water also might lead to an increase of the local gravel size, which increases roughness, decreasing flow velocities again. As the banks at the straightened section usually are fixed by shoreline riprap, the down cutting of the river does not affect river width locally in this case.

The local sediment balance is also influenced by sediment delivery from the catchment upstream (Lach and Wyzga, 2002). But the effects of channelization also affect river sections up- and downstream of the straightened section (Brookes, 1988). The effects on the upstream site are similar to the local effects; steepening the water level upstream of the realigned reach leads to an increase in flow velocity and sediment transport capacity, which leads to downcutting of the river, called river bed degradation (Fig. 8).

Followed by this, the river banks might become instable and might be eroded leading to a subsequent increase in river width. This has a negative feedback on the flow velocity in low flow situations due to the increased contact of water with the river bed leading to increased friction which decreases flow velocity and sediment transport capacity. In the downstream section, which remains unaltered in slope, that is therefore lower there, the sediment eroded from the channelized section accumulates due to the lower flow velocity and transport capacity of the river. This leads to an increase of the river bottom height, a decrease of the channel transport capacity for water, and an increase of the flood risk downstream of the channelized reach. Furthermore, the prevention of local flooding decreases the duration and frequency of local flooding and therefore the retention of water, why more water arrives earlier at the downstream section increasing the

flood risk there (Brookes, 1985b). Together with a decrease of the groundwater table, the typical floodplain vegetation diminishes. Finally in the course of time the river tends to achieve a new equilibrium by minimizing the mechanical energy and local energy dissipation due to adjustments of width and depth and sedimentation processes (Simon, 1992).

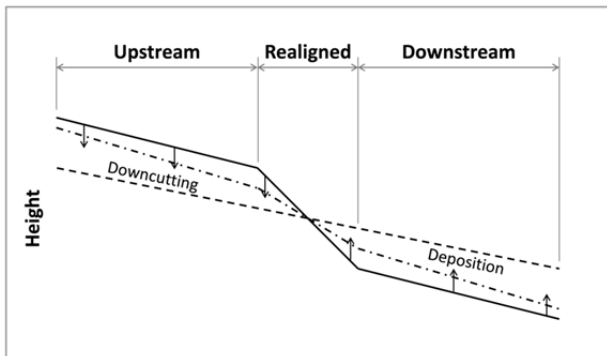

Figure 8: River bed degradation in straightened (realigned) river sections (redrawn from Brookes, 1988).

4.1.2 Step 2 – advanced use of LS 1: creating a semantic and a conceptual causal model

Topic	Natural processes forming riverine landscapes and habitats & Flood protection		
Author(s)	Andreas Zitek	Version(s)	DynaLearn 0.9.5(CM)
Model files	BOKU_LS1 channelization.hgp BOKU_LS1 channelization_advanced.hgp		
Target users	Master students		

Once the topic has been explored, and a short summary in text form and the relevant literature has been prepared, the next step is the development of a conceptual causal model at LS 1. **LS 1** is hereby typically used to capture the **semantic structure** of knowledge by articulating verbally the proposed concepts involved and their relations. It can be considered as a first modelling step mobilizing and structuring existing knowledge, following a typical concept map strategy where nodes (concepts, constructs or ideas) are linked with verbal connectors (statements about the relationships between concepts) (Fig. 9); new information from different sources can be integrated with prior knowledge on a semantic level forming a semantic foundation for understanding a domain (Jonassen and Strobel, 2006).

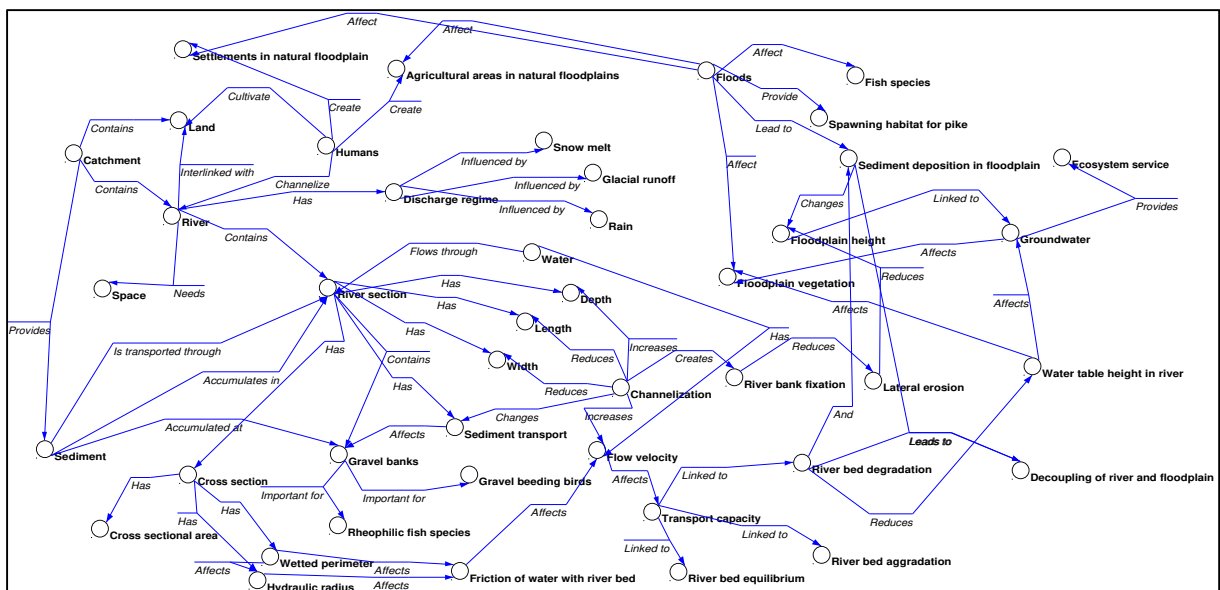

Figure 9: Initial conceptual semantic model on river channelization (,BOKU_LS1 channelization.hgp'.)

In an **advanced mode**, **LS 1** could also be used to construct an initial simple causal diagram using positive and negative relations; '+' hereby means, that if one parameter increases (positive causal relation), the other one also increases, and '-' if one parameter increases, the other one decreases (negative causal relation) (Fig. 10). This strategy might help to focus on causal relations already at LS 1. Furthermore, one could also start to think about the entities involved, as entities represent the basic structural element at all higher LSs. Entities and their relations could also be organized in tables (Tab. 2).

Usually a LS 1 activity starts at one main parameter, e.g. river bed degradation, and consequently all other relevant physical and biological parameters are added. In a following step, the entities, to which the dynamic identified system elements belong, are identified. These are usually clearly observable units/system elements with surfaces and specific properties that can change. Only on the basis of defined entities, hierarchical relations can be understood and formulated.

This step is especially relevant, as at LS 2 and higher, the model structure is based on entities linked by configurations, each equipped with quantities. Following Ahl and Allen (1986) entities could be definitional or empirical. This means, that we might think that something represents an entity at the beginning, while later we will treat this element as quantity of another entity. The entities should hereby be defined in a way to maximise clarity of model structure. E.g. it might be sometimes useful, not to treat water or sediment as entities, but as associated quantities attached to a river reach, hence treating amount of water and amount of sediment as dynamic features of a given site.

As a rule, the definition of entities should support a clear understanding of the hierarchical system structure. The model might still be imperfect, but serves as important input for model building at LS 2.

Initially LS 1 was primarily meant for capturing ideas about the system on a semantic level without the consideration of explicit causal notation. However, we think that the proposed use of LS 1 might help to establish an important link to the model building activity at LS 2, where the development of an entity structure together with the according quantities is required. A LS 1 model developed according to the proposed strategy might hereby serve as an important conceptual input for the development of a simple dynamic simulation based on causal relations between quantities related to entities organized in a hierarchical manner at LS 2.

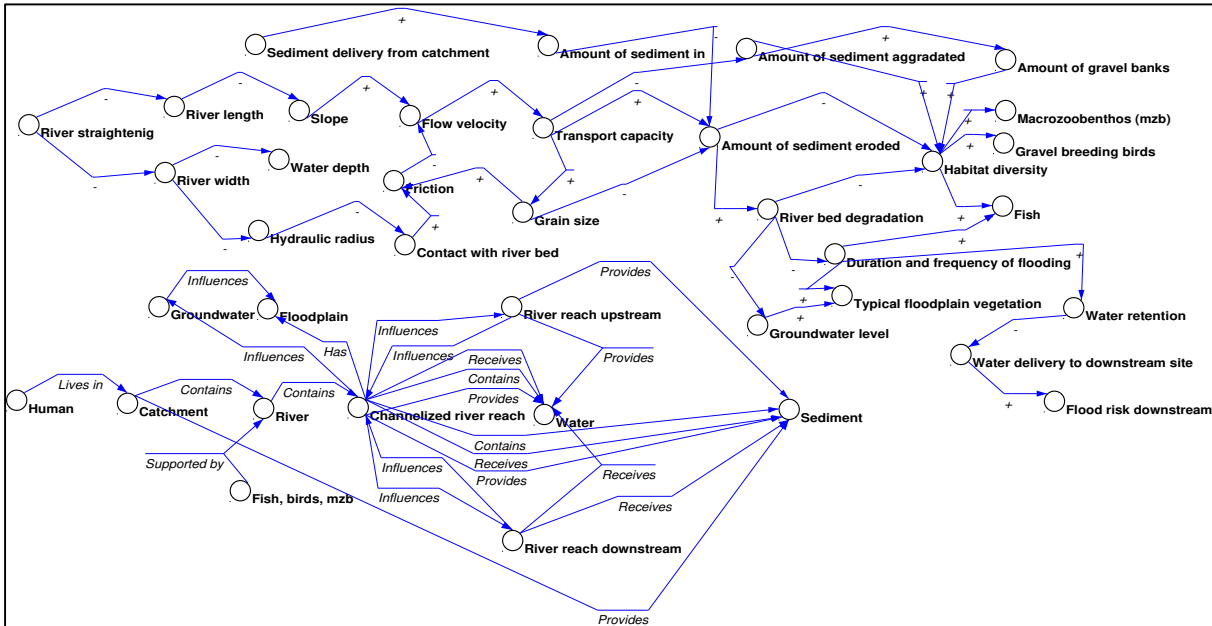

Figure 10: Conceptual causal model (upper) and conceptual entity model (lower) of the model 'BOKU_LS1 channelization_advanced.hgp'.

Table 2: Definitional entities and their configurations in the 'River channelization' model.

Entity source	Configuration	Entity target
Human	Lives in	Catchment
Catchment	Contains	River
	Provides	Sediment
Fish, birds, mzb	Supported by	River
River	Contains	Channelized river reach
		Upstream river reach
		Downstream river reach
Channelized river reach	Influences	Upstream river reach
		Downstream river reach
	Contains	Water
	Contains	Sediment
	Receives	Water
	Receives	Sediment
	Provides	Water
	Provides	Sediment
Upstream river reach	Influences	Channelized river reach
	Provides	Sediment
	Provides	Water
Downstream river reach	Influences	Channelized river reach
	Receives	Water
	Receives	Sediment

4.1.2.1 Learning goals

Content

- Initial identification of the main system elements and their relations
- Focus on the student's web of belief with possible integration of information from other sources

Modelling

- Semantic formulation of the initial understanding of the problem
- Introduction of the concept of entities and hierarchy in ecosystems
- Potentially introduction of the notion of causal loop diagrams
- Identification of possible feedback loops

4.1.2.2 Evidence & causality

The model is based on lots of study results, the underlying physical causal principles of river channelization effects are well scientifically documented (Brookes, 1985a, b, 1987, 1988; Brookes et al., 1983; Simon, 1989, 1992; Wyzga, 1993; Zawiejska and Wyzga, 2010), and even some publications containing conceptual causal models (Brookes, 1988; Wyzga, 1993). The known generic link between habitat diversity and the biota (Brookes, 1988; Jungwirth et al., 1993; Shields et al., 2010; Wyzga et al., 2009) is not expressed in deep causal

detail, and represents only a generic linkage. The modeller here is in responsibility to define the granularity or level of aggregation (resolution or scale) of his/her model (Clariana and Strobel, 2008). Depending on the focus of the model, a model will always contain more detailed direct causal relations, and some more generic simplified aggregated causal relations, that could be called 'domain specific evidence based linkages'. The intentional, domain specific definition of these aggregated linkages is strongly linked to the concept of epistemic causality (Russo and Williamson, 2007).

4.1.2.3 *Ecosystem properties*

Hierarchy

The catchment receives water from precipitation, sets the geomorphological framework (geology, landform etc.) and provides sediment to local river reaches (Dollar et al., 2007). The channelized river reach, the river reaches upstream and downstream are situated at the same hierarchical level, but influencing each other. All of them receive input from the catchment situated at the highest hierarchical level. Human influences can take place at all levels. Fish might also react on different scales. Biota in general can be also influenced on different levels, the individual, the local fish stock, the population, the meta-population and the eco-region and global distribution level, or at the community level (Imhof et al., 1996). A local channelization is supposed to mainly influence individuals, local fish stocks and community composition (Jungwirth et al., 1993). If channelization becomes a large scale impact it might have also an influence on population and meta-population level.

Thermodynamics

Rivers are open systems, and fluvial landforms are produced by the power of water during and gravitational forces (Leopold and Langbein, 1962), with the physical structures changing over many spatial and physical scales (Thorp et al., 2006). To initiate such kind of processes, first energy must be generated, and the subsequent work performed will result in the creation of specific physical processes and finally in the dissipation of energy. The hydrological cycle powered by the energy of sun provides the potential and kinetic energy that is then able to do work to shape the form of channel. The consideration of river energy is central to the study of fluvial geomorphology.

The potential energy rivers possess actually originates from the sun which evaporates water from the sea enabling its deposition at higher levels as precipitation over land. Water stored at any height above the sea level has a certain amount of potential energy to perform work in the river channel as a result of its vertical distance from the base level and the amount of water. The greater the amount of water and the higher the vertical distance, the more potential energy the river possesses. From the potential energy the kinetic energy is derived by the downstream movement of water caused by gravitational forces, where the amount of energy is determined by the volume of flowing water and its mean velocity. The discharge is calculated by multiplying the volume of water and flow velocity. Increasing in any of these parameters will result in an increase in the amount of kinetic energy able to do work and forming the river channel.

The energy of a river is used up during the downstream movement of the water, when the river experiences frictional drag, transports sediment load and erodes its channel. It is these processes that shape the form of actual river type within a 'functional process zone' (FPZ) sensu Thorp et al (2006) (e.g. constrained, meandering, anabranching, braided) given the overall geomorphological setting.

The actual river channel therefore always is an expression of the geomorphological setting (including size of catchment, valley form, slope, sediment delivery, sediment size etc.) and the energetic forces of water being

active. The dependence of the river system from the interaction of these parameters explains sensibility of the dynamic equilibrium the FPZ's to any changes in the geomorphological setting (sediment delivery, change of slope, change in discharge) (Piégay et al., 2006; Surian et al., 2009). These changes might be caused by natural variations (climate change, orogenic processes) or anthropogenic activity (sediment retention, sediment mining, water abstraction, river straightening etc.).

Generic system patterns

Generic system patterns that could easily be identified are inflow and outflow of water and sediment leading to aggradation, degradation, erosion. Feedback loops exist between the a bigger sediment size as a result of a higher sediment transport capacity, which increases the friction of water, decreases flow velocity which again decreases sediment transport capacity.

4.1.2.4 Assumptions and limitations

It is assumed that a meandering river is channelized by straightening, increasing the local slope. As river widenings as channelization measures usually require maintenance as the lowered transport capacity during low flow leads to sediment aggradation (Brookes, 1988), the focus is on river straightening with its related effects. The effect of physical habitat alterations on aquatic biota is only generically expressed. It is also assumed that the sediment delivery from the catchment remains stable and unaltered, and river bed degradation takes place primarily due to channelization

4.1.3 Step 3 - Implementation of an advanced basic causal model at LS 2

Topic	Natural processes forming riverine landscapes and habitats & Flood protection		
Author(s)	Andreas Zitek	Version(s)	DynaLearn 0.9.5(CM)
Model files	BOKU_LS 2 channelization_advanced.hgp		
Target users	Master students		

An advanced model building strategy at LS 2 is characterized by awareness with regard to the hierarchical relationship between entities. To start a model at LS 2, it is first required to define the entities that could have been identified during the advanced LS 1 activity, and to set the configurations between them.

Following the definition of the entity structure, the identified quantities are added to the related entities (Fig. 11 and Tab. 3). During adding the quantities to the entities, you might decide, to leave some entities, and to add them only as characteristics to the higher order entity. This might be mainly done for the reason of structural clarity of the model, and might also be a modelling step where definitional entities are changed to empirical entities sensu Ahl and Allen (1986).

In this case, this was done, because the same quantities re-appear as characteristics at different entities involved which makes it necessary to add them as individual quantities to keep a clear model structure. For upper and lower reaches only the main relevant characteristics are shown. It is very helpful to arrange entities and quantities graphically well, to support visual understanding. The starting point for the simulation is human activity in the catchment, in this case the straightening of a specific river section as a human activity. This could be additionally linked to a need for agricultural area for food production or flood protection for human infrastructures as initial cause.

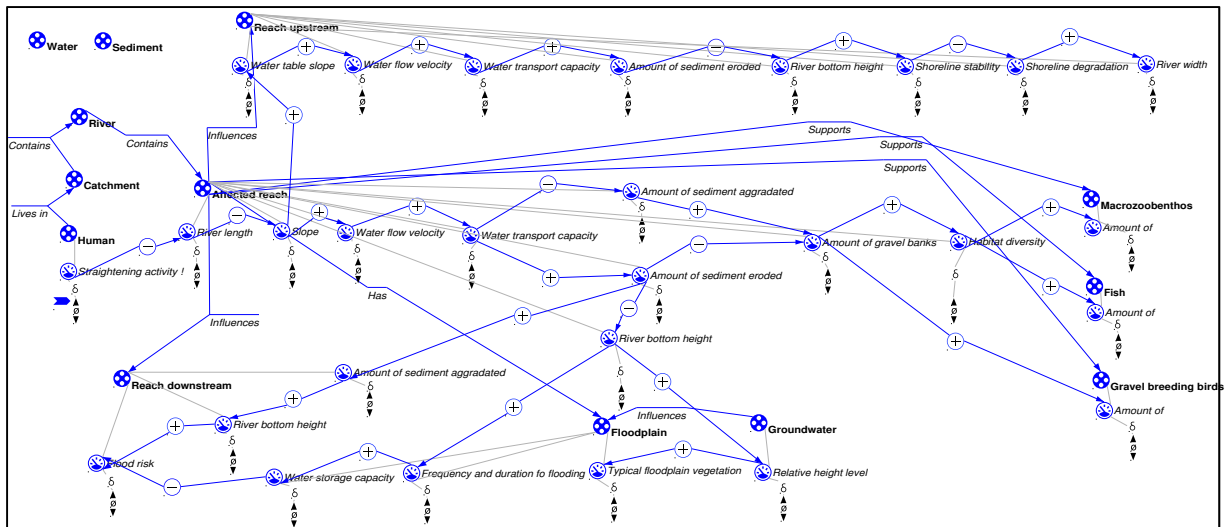

Figure 11: Basic causal model LS 2 on river channelization (BOKU_LS 2 channelization_advanced.hgp)

4.1.3.1 Learning goals

Content

- Development of a general understanding on the causal relations active in the system and their effects on different variables

Modelling

- Development of a problem based entity structure
- Assignment of quantities to the related entities
- Development of dynamic simulation
- Using and understanding the notion of causal relationships
- Evaluation of the simulation results with regard to the intended behaviour
- Getting feedback from repository
- Adoption of the model based on simulation behaviour and feedback

Table 3: Entities, quantities and explanations for a LS2 model on river channelization by channel straightening.

Entity	Quantity	Explanation
Human	Straightening activity	Refers to humans that become active and straighten a river e.g. for flood protection and/or gaining arable land
Catchment	None	Integrated as hierarchical level
River	None	Integrated as hierarchical level
Fish	Amount of	Refers to the amount of fish living in the channelized river reach
Birds	Amount of	Refers to the amount of birds living in the channelized river reach
Macrozoobenthos	Amount of	Refers to the amount of macrozoobenthos living in the channelized river reach
Channelized reach	River length	Parameters of the river reach subjected to channelization
	Slope	
	Water flow velocity	
	Water transport capacity	
	Amount of sediment eroded	
	Amount of sediment aggradated	
	River bottom height	
	Amount of gravel banks	
Floodplain	Habitat diversity	Selected parameters characterizing the floodplain related to river reach subjected to channelization that might be affected
	Typical floodplain vegetation	
	Frequency and duration of flooding	
Reach downstream	Water storage capacity	Selected parameters of the river reach downstream to the channelized river reach that might be affected
	River bottom height	
	Amount of sediment aggradated	
Reach upstream	Flood risk	Selected parameters of the river reach upstream to the channelized river reach that might be affected
	Water table slope	
	Water flow velocity	
	Water transport capacity	
	Amount of sediment eroded	
	River bottom height	
	Shoreline stability	
	Shoreline degradation	
River width		

4.1.3.2 Assumptions and limitations

Only the reaction of the biological entities in the channelized river reach is described. The upstream river reach has no shoreline protection, whereas the shorelines at the channelized river reach are protected from erosion. Negative, balancing feedback loops on the initially changing quantity is not possible, resulting in a question mark during simulation. This is the case, as LS2 allows only for a one-state simulation, where the initial change is assumed, its effect are calculated for the next step, but no further behaviour can be inferred. Positive or negative feedback loops to other variables can be formulated, and do not infer with the simulation; however, as LS2 allows only for a one-step simulation, they are not further processed.

4.1.4 Step 4: Selection of the most important process(es) - causal differentiation

Topic	Natural processes forming riverine landscapes and habitats & Flood protection		
Author(s)	Andreas Zitek	Version(s)	DynaLearn 0.9.5(CM)
Model files	BOKU_LS4_Sediment transport_simple.hgp BOKU_LS4 Bath tub_original.hgp BOKU_LS4 Bath tub_advanced.hgp BOKU_LS4 sediment budget_advanced.hgp		
Target users	Master students		

4.1.4.1 Simple sediment balance model

The most obvious processes being active at a channelized river reach and its associated down- and upstream sections is water and sediment transport as an expression of the river's energy. It's natural to look at these rates directly affecting to the amount of sediment in a river reach, which is related to other features, e.g. the height of the river bottom.

In general the sediment budget of a river reach is based on sediment input and output, gains and losses, and the effect of any imbalance on erosion and aggradation (Fig. 12, Tab. 4). Sediment extraction and other sediment management measures caused by humans (Surian et al., 2009), or changes in sediment transport caused by climate change might reduce sediment delivery from a catchment and hence changing the sediment balance followed by changes river channel form (Piégay et al., 2006). River channelization by straightening increases the output of sediment by an increase of slope and the associated increase of the transport capacity of a river (Brookes, 1988).

Without a specific inequality statement the simulation shows all potential behaviours of the system with three different end states (Fig. 13): if output is bigger than input, the amount of sediment decreases, if input equals output, the amount of sediment stabilizes at low, if input is bigger than output, the amount of sediment in the river reach starts to increase accompanied by an increase of the river bottom height. Putting an inequality statement between the two rates limits the behaviour of the simulation path in one direction. Note, that both rates have a stable derivative, which keeps the rates constant over the duration of the simulation. Removing the derivative stability allows the rates to vary during the simulation, which yields another possible state (stabilization of the system at average river bottom height).

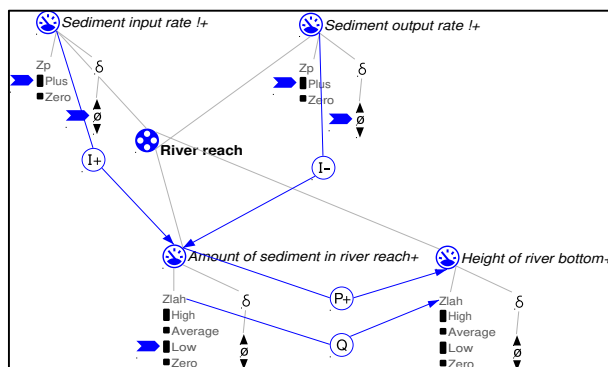

Figure 12: Model expression at LS4 using sediment input and sediment output rates to model the amount of sediment in a river reach and its effect on the height of the river bottom.

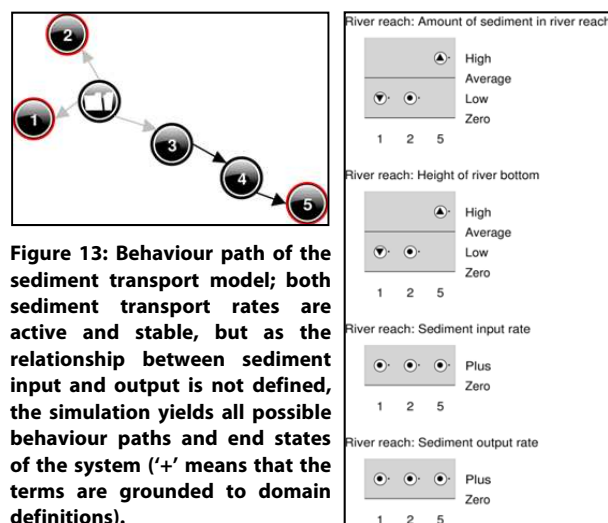

Figure 13: Behaviour path of the sediment transport model; both sediment transport rates are active and stable, but as the relationship between sediment input and output is not defined, the simulation yields all possible behaviour paths and end states of the system ('+' means that the terms are grounded to domain definitions).

Table 4: Entities, quantities and explanations for a LS2 model on river channelization by channel straightening.

Entity	Quantity	QS	Remarks
River reach	Sediment input rate	zp	zero, plus
	Sediment output rate	zp	zero, plus
	Amount of sediment in river reach	zlah	zero, low, average, high
	Height of river bottom	zlah	zero, low, average, high

Learning goals

Content

- To show the effect of sediment input and output on the sediment balance in a river reach and therefore the development of the height of the river bottom.
- To show the effect of imbalances in the sediment budget on the height of the river bottom.
- To stimulate the discussion on the factors that might in/decrease the sediment input, and which abiotic and biotic effects might be related.

Modelling

- To introduce the idea of quantity spaces.
- To introduce the principle of rates adding and subtracting to a state variable via I's.
- To introduce the principle of derivatives.
- To introduce the inequality statements.
- To introduce the principle of proportionalities between state variables.
- To introduce the principle of correspondences to limit simulation behaviour.

Assumptions and limitations

The model assumes, that there is a continuous inflow versus a continuous outflow the rates are stable and not changing. Not defining the derivatives as stable leads to another state (amount of sediment in river reach = average and stable). It also assumes that the amount of sediment in a river reach is positively related to the height of the river bottom.

Although the model provides a powerful representation of the bathtub model typically used in system dynamics to show the effect of inflow and outflow on a state variable, the major limitation of this model (and also the bathtub model) lies in the oversimplification of the nature of rates. There is no initial cause represented that causes the rate to change. The given structure of just a rate in adding and one rate subtracting does not allow for an advanced representation of the initial cause for the change.

4.1.4.2 Advanced sediment balance model I – influence of river length

An advanced model building strategy at LS 4 tries to clearly capture rates and feedback loops creating change and equilibrium.

While in the initial simplified model, the focus was on the sediment inflow and outflow to present the basic dynamic structure of the sediment balance, this representation does not fully capture the nature of rates. From an overall perspective a state variable can be considered to change, because there is an imbalance in the amount of something being added versus the amount of something being subtracted between two system states. The simple representation of an inflow and outflow assumes, that there is a continuous in- and outflow. Especially when dealing with qualitative dynamics, and moreover with ordered system states, an alternative perspective on rates can be applied to explain system behaviour. In DL models, system states accumulate or loose amounts over an unknown time unit. And it is the imbalance between the amounts added or subtracted that causes the change in the state variable. A rate always assumes an amount per time unit, which is already a secondary variable derived from amount divided by time unit. As the time between two system states is unknown, we hypothesize, that it is also appropriate to look at changes of a target variable by subtracting an amount in and an amount out, than simply assuming something flowing in and out – which always is related to a continuous time unit. We assume that the imbalance between the two state variables being added or subtracted is the direct cause of change.

Probably this is the reason, why even highly educated students with extensive technical background demonstrate poor understanding of the stock and flow principles in its original notion (Smith and Gentner, 2010). It might be easier and more natural for learners to first look at a state variable, and then ask for activities/processes that subtract or add a specific amount. Also, constant rates in nature are rare, if even existing. Even the energy from the sun, often assumed to be constant, varies significantly in daily cycle (Jørgensen et al., 2007). Even in this case it is better to talk about the balance of energy received and energy lost, than talking about constant rates of perceiving and loosing. Summarizing, it seems to be more insightful to talk about an amount received and an amount lost between different system states due to initial causes acting on the state variable contributing or subtracting to the state variable of interest. What we are really looking for is the rate of change of the state variable, which can be calculated from the differences in the amount of input and amount of output. This change is caused due to effects on the amounts added and subtracted. This idea is shown in Fig. 14.

The amount added or amount removed are affected by a causal influence somewhere in the system, with the propagating effects changing the amounts, and causing the imbalance.

However, when the maximum value of the bathtub is reached, the water level cannot increase anymore, although the amount added might stay the same. Therefore a conditional statement is needed, setting the water table change rate to zero when the maximum value is reached. This is available at LS 5.

Situations where the principle of calculating the rate of change by subtracting the two involved variables are population growth (number of births versus number of deaths create a population growth rate; feedback from the population size goes directly to the amounts), biological growth processes (energy taken up by photosynthesis versus energy lost by respiration yields the growth), accumulation of CO₂ in the atmosphere (amount added versus amount removed yields change rate) etc. However, in many cases a model will contain 'simple' rates showing a process going on, and rates calculated by state variables.

A more generic view of this idea is presented in Fig. 15. A rate per se is only needed to stimulate the system behaviour, as system borders have to be defined according to the model goal. Fig. 16 shows, how this principle is used to design a sediment balance model.

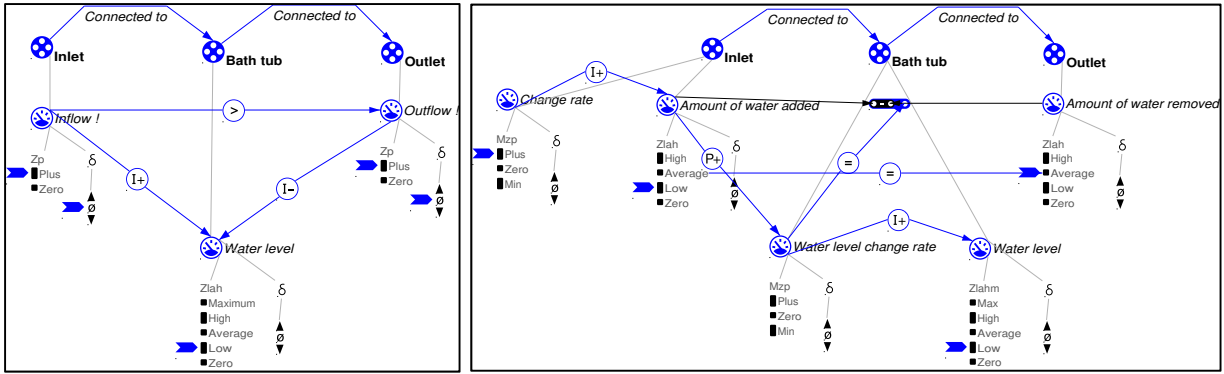

Figure 14: The original bath tub model in DL language focusing on constant flows in and out (left) and the adopted version focusing on a rate created by different amounts removed and added (right); the amount of water removed is set to average between the system states.

In the advanced version of the sediment transport model, a channelized river reach with high slope, high flow velocity and transport capacity is described (Fig. 16). A high amount of sediment is transported out whereas sediment delivery is average and stable, which causes the river bed to degrade. The river bed height is therefore low and decreasing. As rehabilitation measure the river length is increased, affecting the sediment balance. The river bed development rate is calculated as relation between the amount of sediment in and amount of sediment out. As consequence of the initial cause, the increase in river length, the balance is influenced, triggering the river bed development rate. Finally, the river bed height is high and increasing (Fig. 17).

As additional possibility, the model also allows to explore the effect of changed sediment input from the catchment, which is also sometimes a management measure at degrading river sites with excessive transport capacity.

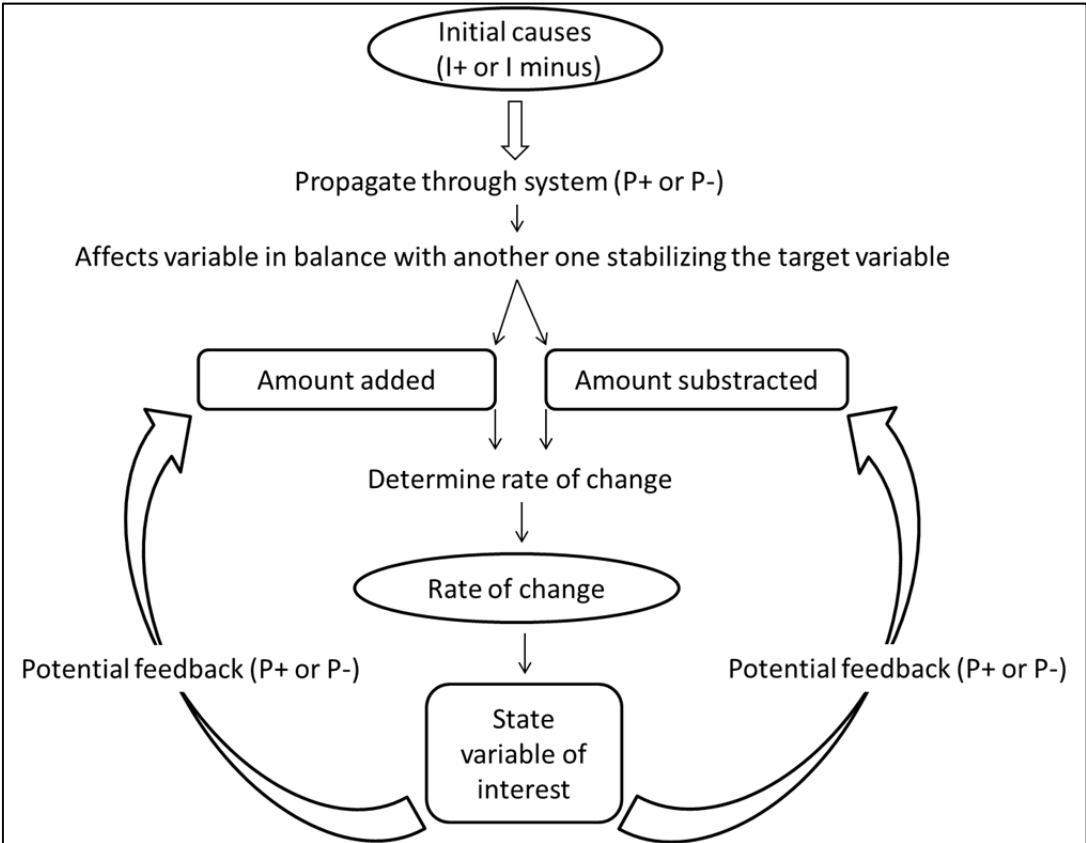

Figure 15: Generic idea of calculating rates of change directly associated to the state variable as relation between two attached state variables.

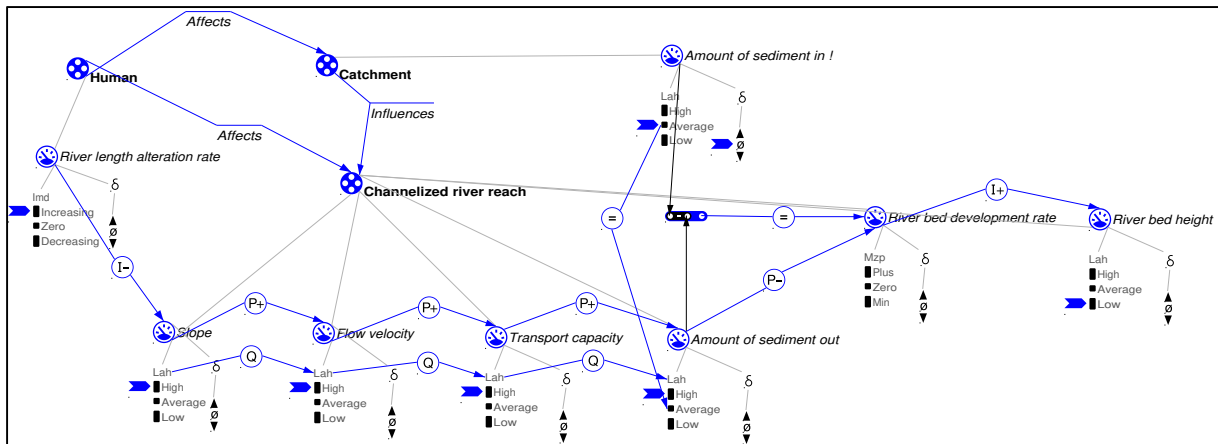

Figure 16: The advanced sediment balance model with a focus on the river bed development rate, that is influenced by the balance of the amount of sediment added and the amount of sediment removed between the system states.

Table 5: Entities, quantities and explanations for an advanced LS 4 model on the change of the sediment balance by increasing the length of a straightened river channel with degradation tendency.

Entity	Quantity	QS	Remarks
Human	River length alteration rate	dzi	Decreasing, zero, increasing
Channelized river reach	Slope	lah	low, average, high
	Flow velocity	lah	low, average, high
	Transport capacity	lah	low, average, high
	Amount of sediment out	lah	low, average, high
	River bed development rate	mzp	minus, zero, plus
	River bed height	lah	low, average, high
Catchment	Amount of sediment in	lah	low, average, high

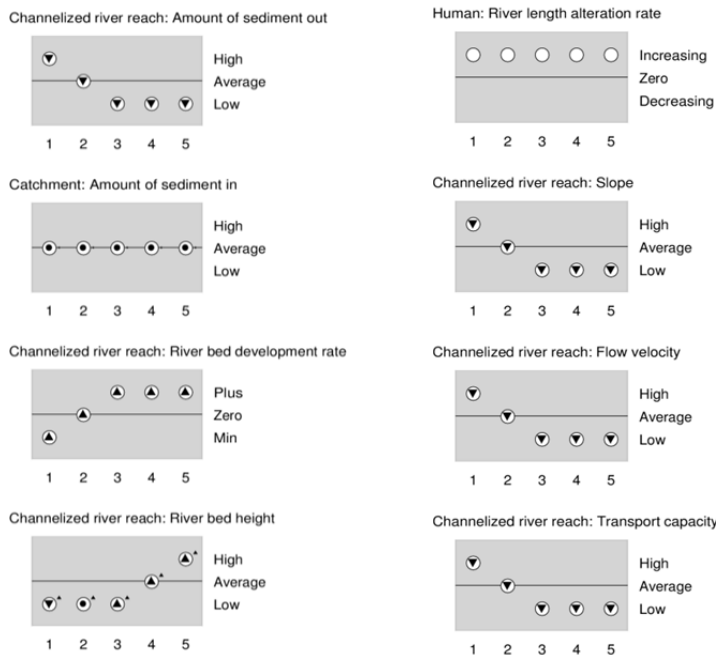

Figure 17: Value history of the advanced sediment balance model with a focus on the river bed development rate.

Learning goals

Content

- Learning about the causal physical effects of river rehabilitation by changing river length.

- Learning that the river bed height development rate depends on the relationship between the amount of sediment in and the amount of sediment out.
- Learning about other potential possibilities to influence this relationship (e.g. sediment provision at a catchment level)
- Thinking about the entities and the spatial levels involved (humans can act local on the river reach, but also might cause effects at a catchment level)

Modelling

- Understanding the nature of rates as imbalance between two state variables.
- Applying the principle of calculating a rate.
- Thinking about the initial cause that propagates through the system influencing the variable of interest.

Assumptions and limitations

The river rehabilitation is seen only as the increase of river channel length acting on the slope. The amount of sediment in is assumed to be average and constant. The model just focuses on the effects of channelization and rehabilitation measures on a local river reach, and does not take into account the associated effects on the up- and downstream river reaches. Consequences on habitat diversity and related biological effects are also not considered. The potential effect on substrate size is not modelled.

4.2 Advanced population models

Population ecology, as one of the three major sub-disciplines of ecology, is dealing with population-level processes including population growth and regulation, and interspecies interactions (Frumkin, 2010).

Advanced population models try to represent populations, their growth and interaction and their relation to environmental factors in a most clear and insightful manner, also establishing a link to fundamental accepted generic patterns of population behaviour.

Topic	Populations		
Author(s)	Andreas Zitek	Version(s)	DynaLearn 0.9.5(CM)
Model files	BOKU_LS4 Population growth affected by habitat restoration.hgp BOKU_LS6 Lotka Volterra_advanced_A.hgp BOKU_LS6 Lotka Volterra_advanced_B.hgp		
Target users	Master students		

4.2.1 Exponential growth, linear growth and logistic growth

Environmental systems often contain feedback loops, that have the potential to strongly influence system's behaviour. One major example is the potential of populations to show exponential growth when no major environmental constraints are given (Turchin, 2001). This is caused by a feedback from the growing number of individuals to the number of births.

However, according to Turchin (2001) simple population models like exponential growth, the Lotka-Volterra model and the logistic growth model, described in many ecological textbooks as fundamental principles, often lack a correspondence in real world systems. Instead of capturing real population behaviour, they are used as powerful 'metaphors' similar to physical laws, e.g. in classical mechanics, to illustrate three basic concepts of population dynamics: exponential population growth, self-limitation, and trophic oscillations (Turchin, 2001).

For introducing exponential, linear and logistic growth in qualitative manner, a LS 4 model is used. It is built following a generic modelling pattern, where an initial change in the environment propagates through the system changing important environmental variables, linked to population parameters. An initial rate is used to trigger the system behaviour, with the change propagating through the system via P's changing the balance between two state variables, creating the rate of change, that is of interest, affecting the state variable of interest (Fig. 18, according to the principle shown in Fig. 15).

The feedback is created by using P's linked back to the adequate state variables. We think, that this generic pattern helps learners to better understand the character of rates. Furthermore, this archetypical model structure is applicable to many situations, why it is supposed to be support learners explore other environmental issues containing feedback loops (transferability to new situations).

Being aware of the conceptual restrictions of the exponential growth model, we assume it is fair to apply the principle of a feedback loop directed from 'Population size (adult individuals)' to 'Number of births' with the potential of yielding exponential growth, when no environmental restrictions are given (Fig. 18). Note that also the 'Number of adult individuals dying' is increasing to the increase in population size, interacting with the population growth rate. In the model described, habitat changes initiated by humans (reflecting river rehabilitation) leads to the creation of the 'Amount of spawning habitat', which then leads to an increase of 'Number of births'. The 'Number of births' affects the 'Number of sub-adults' entering the adult stage; this link conceptually includes an age class model typically used to capture the natural mortality that occurs between 'Number of births' and 'Number of sub-adults' (Noble et al., 2009). A directed correspondence between the quantity spaces of 'Number of births' and 'Number of sub-adults' assumes simultaneity between the amounts available at each system state, although the quantity space of 'Number of sub-adults' refers to a different numerical dimension. A correspondence between zero 'Population size (adult individuals)', the 'Number of births' and 'Number of adult individuals dying' is set, determining the assumption that there is no deaths and births if there is no population existing.

The simulation (when restricted by changes in the preferences settings to control simulation behaviour) shows three end states (Fig. 19), differing in the derivative of the population growth rate: depending on the differences between the 'Number of sub-adult individuals' and 'Number of adult individuals dying' the rate could be increasing (indicating exponential population growth), stable (growth is positive and stabilizes: I am not exactly sure what the positive rate stabilizing is actually indicating, probably another expression of exponential growth) or decreasing (when 'Number of adult individuals' dying becomes bigger than 'Number of sub-adult individuals dying' (indicating potential self-limitation of the population by density depending factors).

Fig. 20 summarizes the potential population behaviour patterns and links continuous functions with qualitative states.

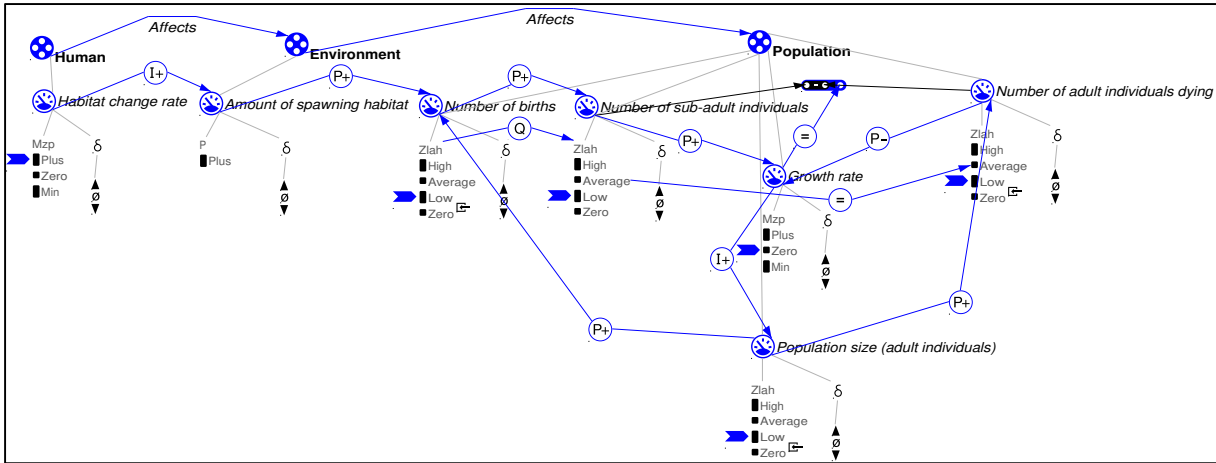

Figure 18: Population model with a focus on the effect of river rehabilitation measures on population growth rate calculated by the balance of ‘Number of sub-adult individuals’ (entering the adult stage) and ‘Number of adult individuals dying’ and affected by feedback loops from ‘Population size (adult individuals)’ to ‘Number of births’ and ‘Number of adult individuals dying’; the correspondence between zero ‘Population size (adult individuals)’, the ‘Number of births’ and ‘Number of adult individuals dying’ is hidden to reduce visual overload (BOKU_LS4 Population growth affected by habitat restoration.hgp).

Table 6: Entities, quantities and explanations for the population growth model.

Entity	Quantity	QS	Remarks
Human	Habitat quality change rate	mzp	minus, zero, plus
Environment	Amount of spawning habitat	p	plus
Population	Number of births	zlah	zero, low, average, high
	Number of sub-adult individuals	zlah	zero, low, average, high
	Number of adult individuals dying	zlah	zero, low, average, high
	Growth rate	mzp	minus, zero, plus
	Population size (adult individuals)	zlah	zero, low, average, high

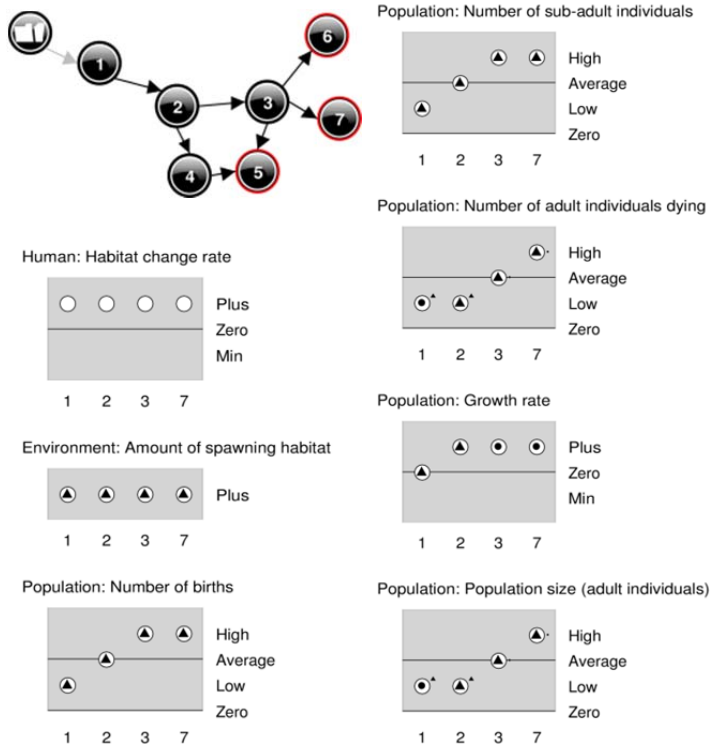

Figure 19: Simulation results and value history of the population model; to control model behaviour the default preference settings of DL were adopted as follows: ‘Apply fastest path heuristics’ was activated and ‘Epsilon ordering’ was set inactive; for a deeper expert exploration of model behaviour these settings have to be set back to default.

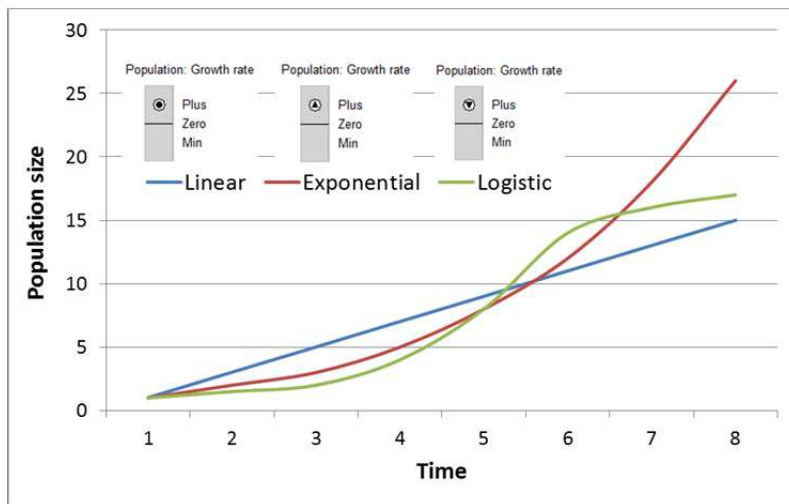

Figure 20: Different population growth patterns (linear, exponential and logistic growth) and their representation using qualitative states of population growth rates (positive and stable, positive and increasing, positive and decreasing).

4.2.1.1 Learning goals

Content

- Learning about the effects of physical habitat rehabilitation on riverine fish populations focusing on the relevance of spawning habitat
- Understanding the effect of an increased availability of spawning places on the amount of fish reproduced
- Understanding the influence of one age class on the size of another age class as a basis for the development of quantitative population models
- Understanding the principle of exponential population growth

Modelling

- Understanding the nature of population growth
- Applying the principle of calculating a rate
- Understanding the nature of feedback loops
- Thinking about the initial cause that propagates through the system influencing the variable of interest
- Elaboration of the strengths and limitations of mathematical versus conceptual models

4.2.1.2 Assumptions and limitations

The habitat quality change rate affects also habitat for other life stages, which is not explicitly modelled and provides habitat also for sub-adults and adults, why the environment is not limiting population growth. The model focuses mainly on spawning habitat as factor for population growth, while the habitat requirements for the other age classes are assumed to be met to support population growth. The amount of

habitat produced is not reflected as quantity space, just indicating a sufficient increase. There is only one direct relationship between 'Number of births' and 'Number of sub-adults' although there might be other relevant ontogenetic stages that could be considered depending on the species. The quantity spaces of Number of births' and 'Number of sub-adults' are assumed to be corresponding, as no other potential effect on the 'Number of sub-adults' is represented (habitat quality, inter-annual differences in survival etc.), although the values of the corresponding quantity spaces are assumed to be different and refer to specific sizes related to each age class represented.

4.2.2 Lotka-Volterra model

The Lotka-Volterra Prey-Predator model involves two equations, one which describes how the prey population changes and the second which describes how the predator population changes. We will look at Lotka-Volterra equation using a Predator-Prey dynamic population of a Herbivore and a Predator. The dynamics of the interaction between a herbivore population H and a Predator population P is described by the differential equations:

$$\frac{DH}{dt} = aH(t) - bH(t)P(t)$$

$$\frac{DP}{dt} = ebH(t)P(t) - cH(t)$$

where,

- a is natural growth rate of H in absence of P ,
- c is natural death rate of P in the absence of food H ,
- b is the death rate per encounter of H due to predation,
- e is the efficiency of turning predated H into P .¹⁷

The advanced Lotka-Volterra model presented here is based on the LS 4 model described in D6.2.5. It is built in LS6, and tries to link generic intra-population processes (number of births, number of deaths, population growth rate, population size) with inter-population processes (population size of the prey affects the population size of the predator and vice versa in an oscillating manner) based on the Lotka-Volterra equations. The model focuses on a clear, pattern oriented representation of population processes, using the interaction between a herbivore (rabbit) and a predator (fox) population. Furthermore, in comparison to the model presented in D6.2.5, it aims at a more insightful representation of the population size by the use of quantity spaces (Tab. 7).

Table 7: Entities, quantities and quantity spaces (QSs) used in the model 'BOKU_LS6 Lotka Volterra_advanced_A'.

Entity	Quantities	QS	Remarks
Rab population	Number of births	lah	low, average, high
	Number of deaths	lah	low, average, high
	Population growth rate	mzp	minus, zero, plus
	Population size	sal	small, average, large
Fox population	Number of births	lah	low, average, high
	Number of deaths	lah	low, average, high
	Population growth rate	mzp	minus, zero, plus
	Population size	sal	small, average, large

¹⁷ <http://amrita.vlab.co.in/?sub=3&brch=67&sim=185&cnt=1>

4.2.2.1 Model expression

The target of this model was not only a simple translation of the elements of the Lotka-Volterra but to focus on a re-usable and generic representation of any population and to add the dynamics as statements between them. In the static model fragment, the inverse correspondence defines, that when the number of births increases, the number of deaths decreases, resulting in a population growth rate that affects the size of the population. For the rabbit population this reflects $aH(t)$ in absence of predation (Fig.21 and Fig. 22).

The 'P+' from the 'population size' of the rabbit population to the 'number of births' of the fox population expresses that an increased availability of the prey results in more births within the fox population integrating the expression $ebH(t)P(t)$ ('*b*, the death rate per encounter of H due to predation' and '*e*, the efficiency of turning predated H into P') (Fig. 39). We furthermore assume that the 'number of deaths' of the fox population is reduced by an increase of the population size of the prey population, whereas the original model only considers the natural death rate of P in the absence of food H as $cH(t)$.

The 'P+' from 'population size' of the fox population to the 'number of deaths' of the rabbit population stands for the expression $bH(t)P(t)$ which is '*b*, the death rate per encounter of H due to predation' (Fig. 40).

The main difference to the original Lotka-Volterra model is, that per population only on rate, the population growth rate, is explicitly modelled as a relation of births and deaths in a given population (with only the population growth rate of the herbivore prey $aH(t)$ explicitly included in the original model; a similar population growth rate for the predator P is lacking within the original Lotka-Volterra equation and is expressed in dependence of the prey as ' $ebH(t)P(t)$ ').

We think the model presented here is a much more clear representation of the original model and allows for the inclusion of different other effects (e.g. 'population size' of prey reduces death rate of P, as modelled here) and other conceptual (corresponding) elements that could be easily incorporated, if a more explicit representation is wanted (e.g. number of prey consumed, number of prey available, etc.).

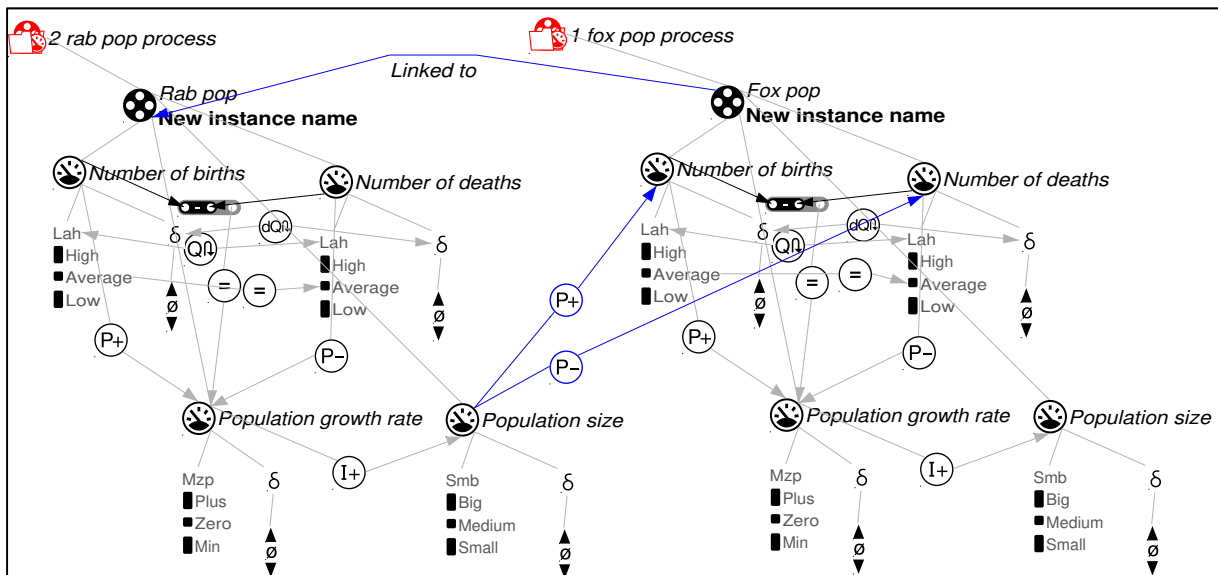

Figure 21: Model expression 'Rabbit population affects fox population'.

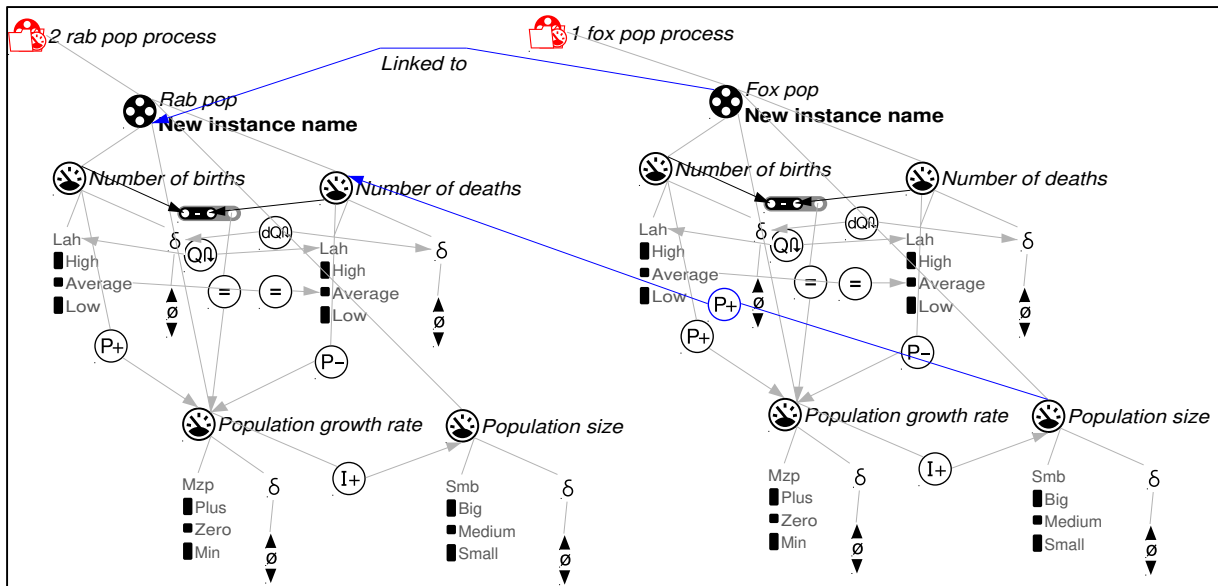

Figure 22: Model expression 'Fox population affects rabbit population'.

4.2.2.2 Scenarios and simulations

The scenario starts with a small fox population, and a big population size of the rabbits (Fig. 23).

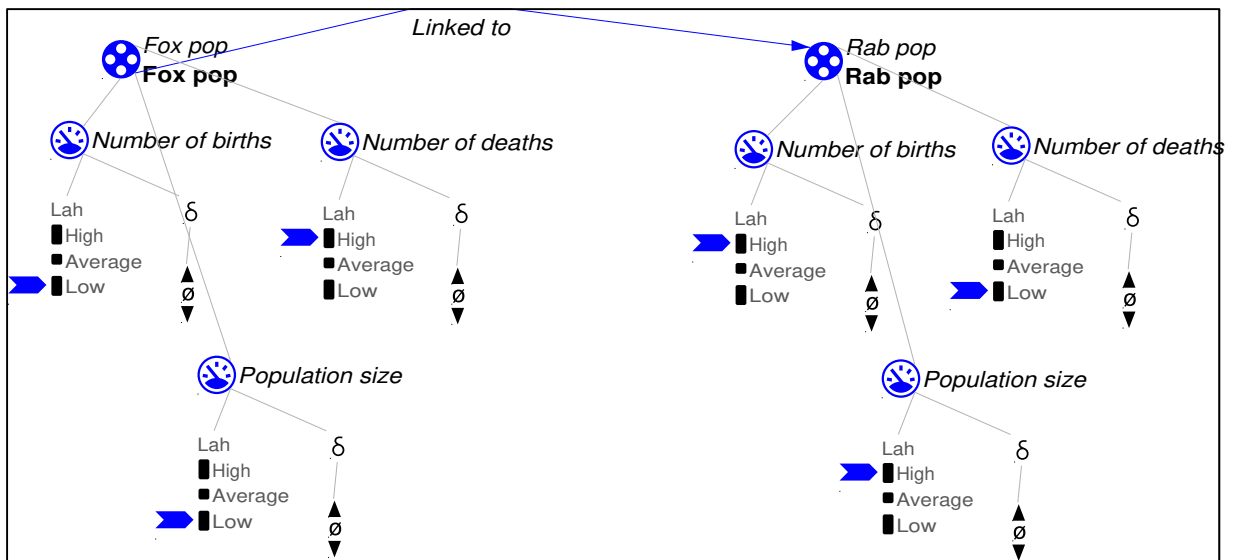

Figure 23: Scenario with initial values of the model 'BOKU_LS6 Lotka Volterra_advanced_A'.

The Lotka-Volterra model in principle shows a circular pattern based on the same processes recurring over time (Fig. 24). Fig. 25 shows the theoretical periodic oscillations of predator-prey populations following the Lotka-Volterra model.

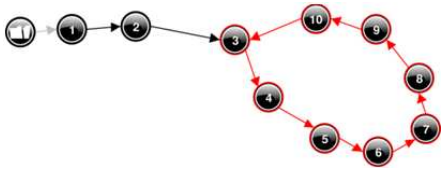

Figure 24: State graph indicating the circular nature of the Lotka-Volterra model.

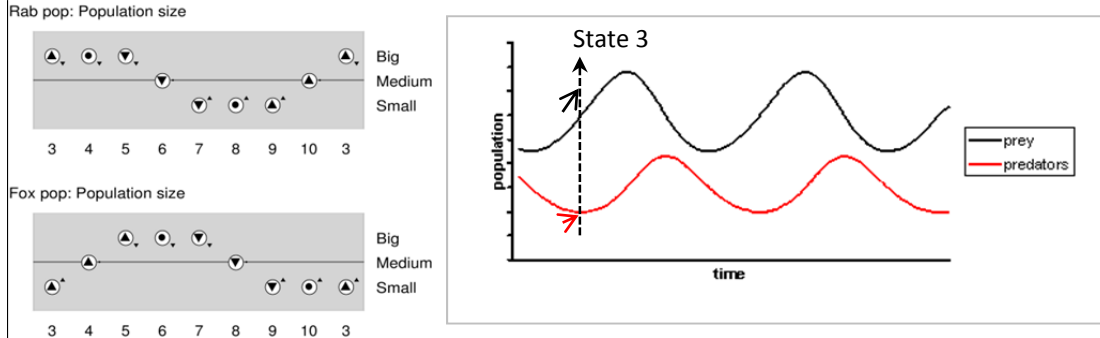

Figure 25: Behaviour path and value history showing the periodic oscillations of predator-prey populations following the Lotka-Volterra model.

Finally the simulation preferences were adopted to yield a clear simulation pattern.

Select preferences for running the simulator:

- | | |
|-----------------------------------------------------------------------------------------------|-------------------------------------------------------------------------------------|
| <input type="checkbox"/> Assume unknown influences to be zero | <input checked="" type="checkbox"/> Apply correspondences in ordering |
| <input type="checkbox"/> Apply quantity space constraints on extreme values | <input type="checkbox"/> Apply epsilon ordering |
| <input checked="" type="checkbox"/> Apply quantity space constraints on zero as extreme value | <input checked="" type="checkbox"/> Apply epsilon merging of immediate terminations |
| <input type="checkbox"/> Assume equal quantity spaces have equal points | <input type="checkbox"/> Apply epsilon derivative continuity constraints |
| <input type="checkbox"/> Generate all values for calculated quantities | <input type="checkbox"/> Remove inactive quantities after transition |
| <input checked="" type="checkbox"/> Apply Fastest Path Heuristic | |

4.2.2.3 Learning goals

Content

- Understanding the basic concept of the Lotka-Volterra model
- Understanding the potential and limitations of the Lotka-Volterra model
- Identification of number of births and number of deaths as basic elements of population growth
- Interaction between a herbivore and a predator population
- Discussion which other factors might influence both populations

Modelling

- Basic pattern for representing populations based on a population growth rate calculated as a result of number of births and number of deaths
- Use of correspondences to limit simulation behaviour

- Creation of circular simulation patterns
- Exploration of the effects of the preference settings
 - epsilon ordering
 - fastest path heuristic
- Elaboration of the strengths and limitations of mathematical versus conceptual models

4.2.2.4 Assumptions and limitations

The model focuses on the interaction between two populations, assuming that there always will be a population of both species. The complete extinction of one of the populations is not foreseen by the model, as the state 'zero population size' is not included in the quantity space.

No feedback is modelled from population size to number of births, which could be implemented via a 'P+' from 'population size' to 'number of births' (Fig. 26). Due to the inverse correspondences between the quantity spaces and derivative of 'number of births' and 'number of deaths' there might be a conflict during the simulation, why these inverse correspondences have to be removed. As additional ambiguity is introduced by this step, the simulation yields much more states. However, a circular path will show again the oscillation of both populations in interdependence. In principle the problem arises, to keep the model structure clear and insightful while the simulations still should work properly.

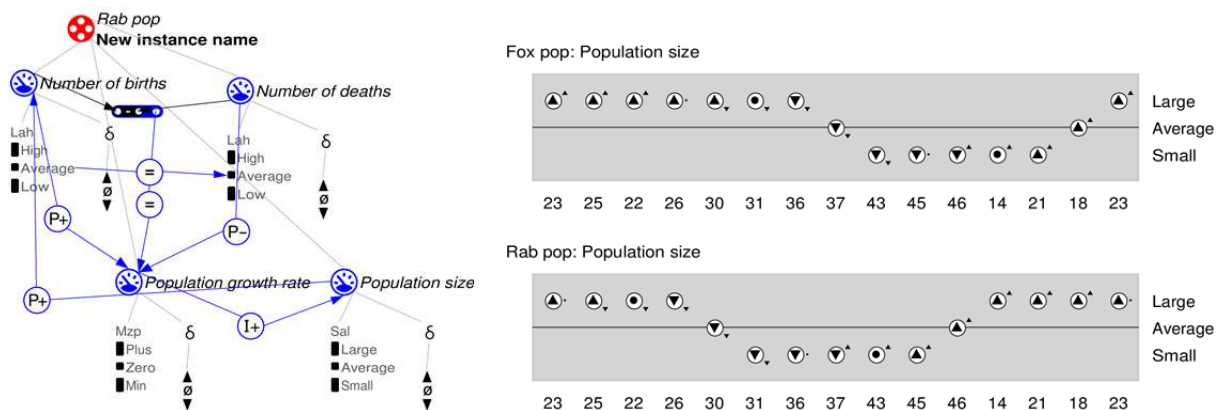

Figure 26: Process fragment of the rabbit population with feedback from population size to the number of births (note that the correspondences between 'number of births' and 'number of deaths' have been removed) (left) and simulation results as value history of the population sizes of both populations (right) ('BOKU_LS6 Lotka Volterra_advanced_B').

From a population ecology perspective we assume that the increased prey availability (expressed as the population size of rabbits) will also decrease the mortality (number of deaths) of the fox population (more food, less competition, healthier individuals, less time to invest in predation etc.).

Furthermore in principle *'the classic, textbook predator-prey model proposed by Lotka and Volterra in 1927; in words, states that;*

- *Each prey gives rise to a constant number of offspring per year; In other words, there are no other factors limiting prey population growth apart from predation.*
- *Each predator eats a constant proportion of the prey population per year; In other words, doubling the prey population will double the number eaten per predator, regardless of how big the prey population is.*

- *Predator reproduction is directly proportional to prey consumed; Another way of expressing this is that a certain number of prey consumed results in one new predator; or that one prey consumed produces some fraction of a new predator.*
- *A constant proportion of the predator population dies per year. In other words, the predator death rate is independent of the amount of food available.*

To simplify the complexity of the dynamic models being studied, we make some assumptions. Generally, we will make some assumptions that would be unrealistic in most of these predator-prey situations. For better understanding we will explain it using the example of the Fox-Rabbit population. Here, we assume that;

1. *The predator species is totally dependent on a single prey species as its only food supply,*
2. *The prey species has an unlimited food supply and*
3. *There is no threat to the prey other than the specific predator'.¹⁸*

¹⁸ <http://amrita.vlab.co.in/?sub=3&brch=67&sim=185&cnt=1>

4.3 The evolution of the sun

Topic	Natural processes forming riverine landscapes and habitats		
Author(s)	Andreas Zitek	Version(s)	DynaLearn 0.9.5(CM)
Model files	BOKU_sun evolution_LS6_advanced.hgp		
Target users	Master students		

4.3.1 Topic summary

1. *'A cloud of gas and dust begins to contract under the force of gravity. In regions of star birth, we find gaseous nebulae and molecular clouds. These sites of pre-birth are dark patches called globules.*
2. *The protosun collapsed. As it did, its temperature rose to about 150,000 degrees and the sun appeared very red. Its radius was about 50 present solar radii.*
3. *When the central temperature reaches 10 million degrees, nuclear burning of hydrogen into helium commences.*
4. *The star settles into a stable existence on the Main Sequence, generating energy via hydrogen burning. This is the longest single stage in the evolutionary history of a star, typically lasting 90% of its lifetime. Thermonuclear fusion within the Sun is a stable process, controlled by its internal structure.*
5. *The hydrogen in the core is completely burned into helium nuclei. Initially, the temperature in the core is not hot enough to ignite helium burning. With no additional fuel in the core, fusion dies out. The core cannot support itself and contracts; as it shrinks, it heats up. The rising temperature in the core heats up a thin shell around the core until the temperature reaches the point where hydrogen burning ignites in this shell around the core. With the additional energy generation in the H-burning shell, the outer layers of the star expand but their temperature decreases as they get further away from the centre of energy generation. This large but cool star is now a red giant, with a surface temperature of 3500 degrees and a radius of about 100 solar radii.*
6. *The helium core contracts until its temperature reaches about 100 million degrees. At this point, helium burning ignites, as helium is converted into carbon (C) and oxygen (O). However, the core cannot expand as much as required to compensate for the increased energy generation caused by the helium burning. Because the expansion does not compensate, the temperature stays very high, and the helium burning proceeds furiously. With no safety valve, the helium fusion is uncontrolled and a large amount of energy is suddenly produced. This helium flash occurs within a few hours after helium fusion begins.*
7. *The core explodes, the core temperature falls and the core contracts again, thereby heating up. When the helium burns now, however, the reactions are more controlled because the explosion has lowered the density enough. Helium nuclei fuse to form carbon, oxygen, etc..*
8. *The star wanders around the red giant region, developing its distinct layers, eventually forming a carbon-oxygen core.*
9. *When the helium in the core is entirely converted into C, O, etc., the core again contracts, and thus heats up again. In a star like the Sun, its temperature never reaches the 600 million degrees required for carbon burning. Instead, the outer layers of the star eventually become so cool that nuclei capture electrons to form neutral atoms (rather than nuclei and free electrons). When atoms are forming by capturing photons in this way, they cause photons to be emitted; these photons then are readily available for absorption by neighbouring atoms and eventually this causes the outer layers of the star to heat up. When they heat up, the outer layers expand further and cool, forming more atoms, and releasing more photons, leading to more expansion. In other words, this process feeds itself.*
10. *The outer envelope of the star blows off into space, exposing the hot, compressed remnant core. This is a planetary nebula.*
11. *The core contracts but carbon burning never ignites in a one solar mass star. Contraction is halted when the electrons become degenerate, that is when they can no longer be compressed further. The core remnant has a surface temperature of a hot 10,000 degrees and is now a white dwarf.*

12. With neither nuclear fusion nor further gravitational collapse possible, energy generation ceases. The star steadily radiates energy, cools and eventually fades from view, becoming a black dwarf. With this understanding of how the Sun will evolve, we can follow its evolution on the HR diagram'.¹⁹

The simplified evolution of the sun is shown in Fig. 27.

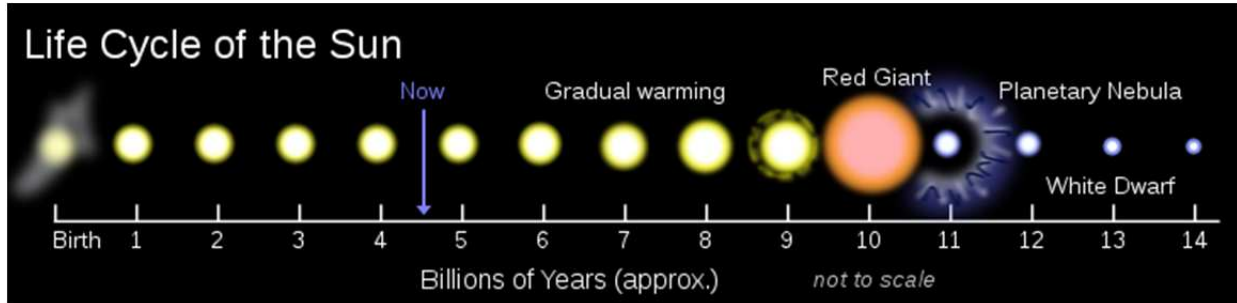

Figure 27: Evolution of the sun.²⁰

4.3.1.1 Hertzsprung-Russell Diagram

The Hertzsprung-Russell Diagram (Fig. 28) is a graphical tool that astronomers use to classify stars according to their luminosity, spectral type, colour, temperature and evolutionary stage. Stars in the stable phase of hydrogen burning lie along the Main Sequence according to their mass. After a star uses up all the hydrogen in its core, it leaves the main sequence and moves towards the red giant branch. The most massive stars may also become red supergiants, in the upper right corner of the diagram. The lower left corner is reserved for the white dwarfs'.²¹

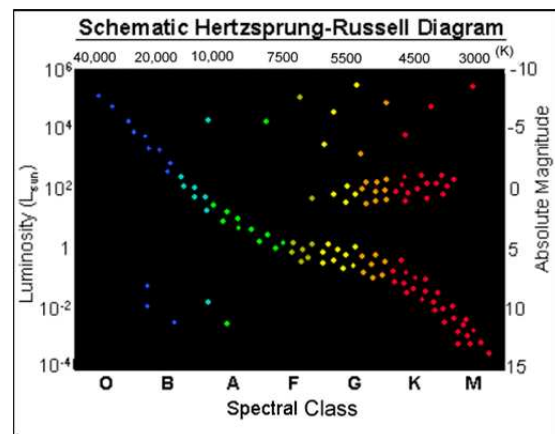

Figure 28: The Hertzsprung-Russell Diagram.²²

The Sun's (and solar-like stars') interior can be divided into three distinct zones (Fig. 29): The uppermost is the Convective Zone. It extends downwards from the bottom of the photosphere to a depth of about 15% of the radius of the Sun. Here the energy is mainly transported upwards by (convection) streams of gas. The Radiative Zone is below the convection zone and extends downwards to the core. Here energy is transported outwards by radiation and not by convection.

From the top of this zone to the bottom, the density increases 100 times. The core occupies the central region and its diameter is about 15% of that of the entire star. Here the energy is produced by fusion processes through which hydrogen nuclei are fused together to produce helium nuclei. In the Sun, the temperature is around 14 million degrees. In red giants, the convection zone is much larger, encompassing more than 35 times more mass than in the Sun'.²³

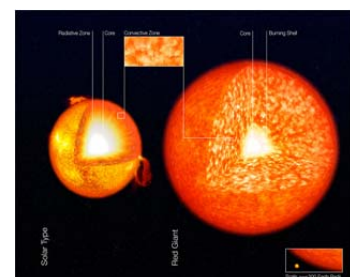

Figure 29: The structure of a solar-like star and a red giant, scale in the lower right corner.

¹⁹ http://astrosun2.astro.cornell.edu/academics/courses/astro201/evol_sun.htm

²⁰ http://en.wikipedia.org/wiki/Formation_and_evolution_of_the_Solar_System

²¹ http://www.astro.cornell.edu/academics/courses/astro201/hr_diagram.htm

²² http://www.astro.cornell.edu/academics/courses/astro201/hr_diagram.htm

²³ <http://www.eso.org/public/images/eso0729a/>

Tab. 8 contains the main entities and quantities identified within the sun evolution cycle.

Table 8: Entities, quantities and quantity spaces (QSs) used in the model 'BOKU_sun evolution_LS6_advanced'.

Entity	Quantities	QS	Remarks
Initial cosmic cloud	Gravitational forces	lah	low, average, high
	Pressure	lah	low, average, high
	Temperature	lah	low, average, high
	Collaps process	zp	zero, plus
Sun main sequencs	Amount of H transformed into He	lah	low, average, high
	Amount of H	lah	low, average, high
	Amount of He	lah	low, average, high
	H to He rate	zp	zero, plus
Red giant	Size	lah	low, average, high
	Temperature	lah	low, average, high
	Amount of He	lah	low, average, high
	Amount of C	lah	low, average, high
	Amount of O	lah	low, average, high
	He burning process	zp	zero, plus
Planetary nebula	Blow off of outer layers	zp	zero, plus
White dwarf	Core contraction	zp	zero, plus

4.3.2 Model expression

4.3.2.1 Entity hierarchy

The entities used to model sun evolution are shown in Fig. 30.

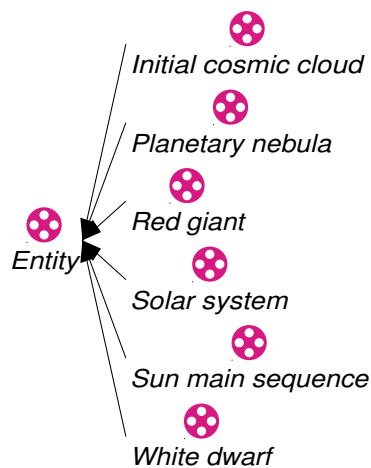
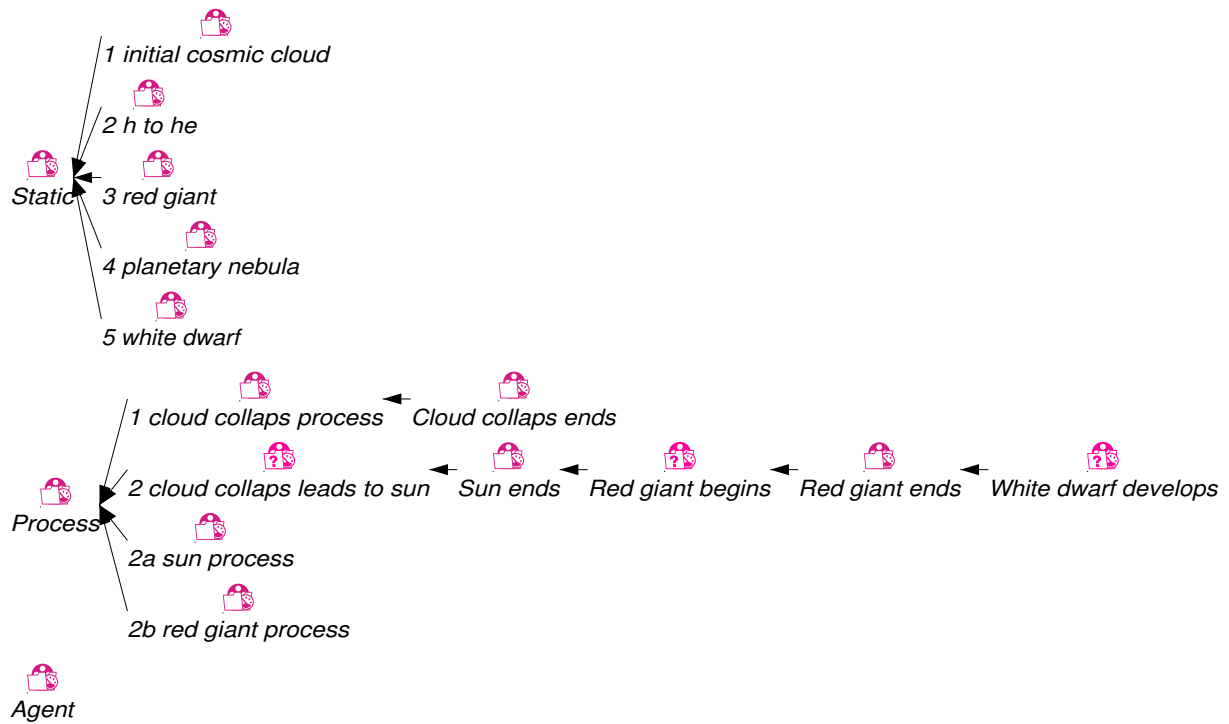
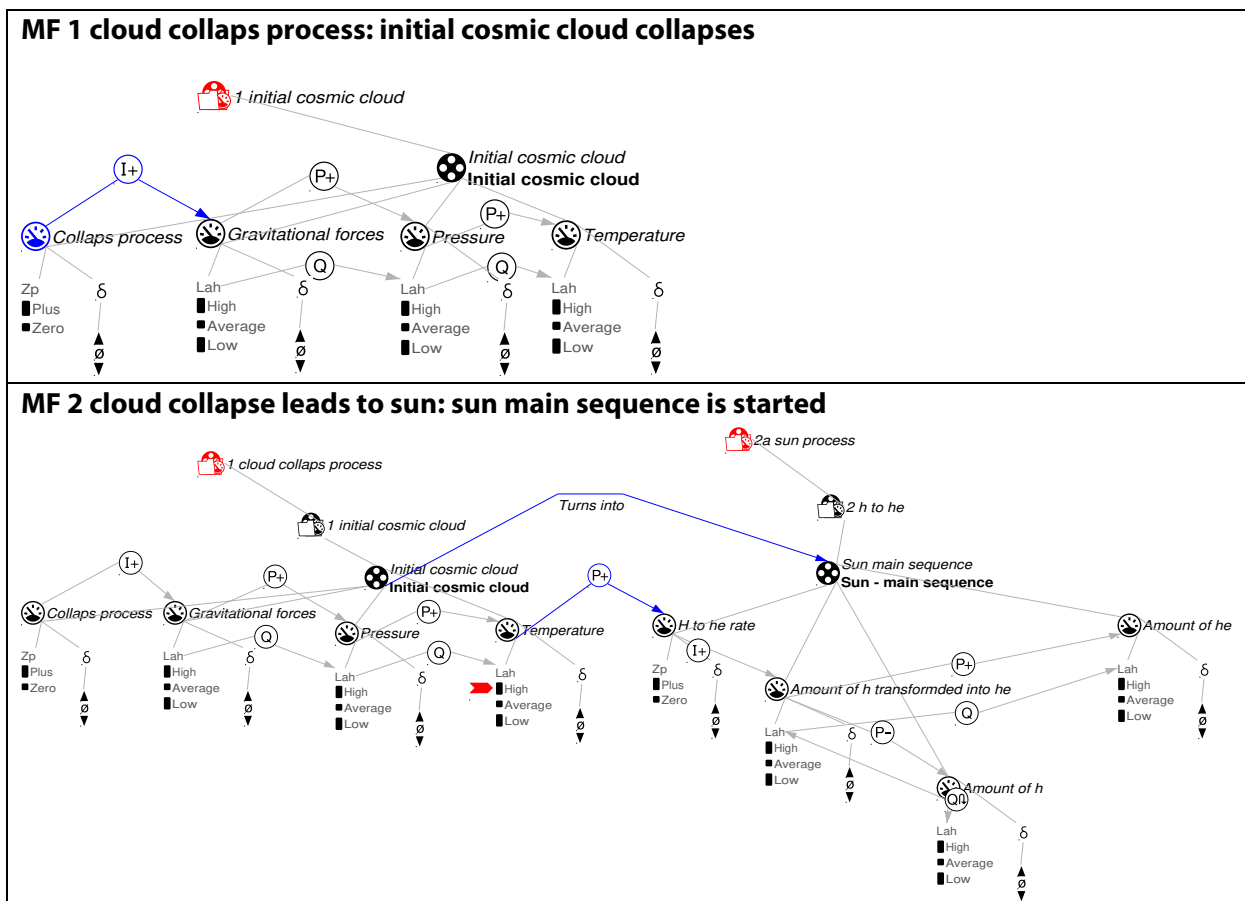

Figure 30: Entity hierarchy of the model 'BOKU_sun evolution_LS6_advanced'.

4.3.2.2 Model fragment hierarchy



4.3.2.3 Model fragments



MF sun ends: sun main sequence is ended

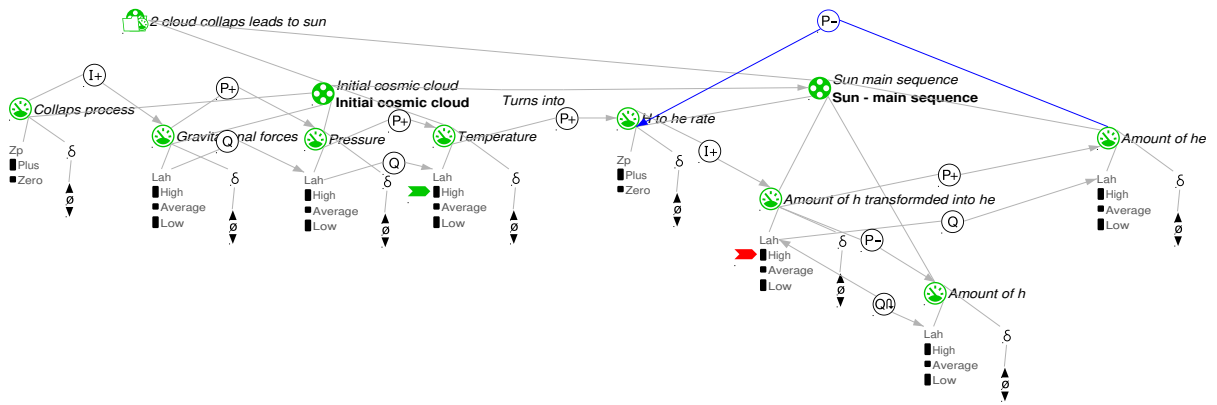

MF red giant begins: the He burning process typical for the red giant process begins

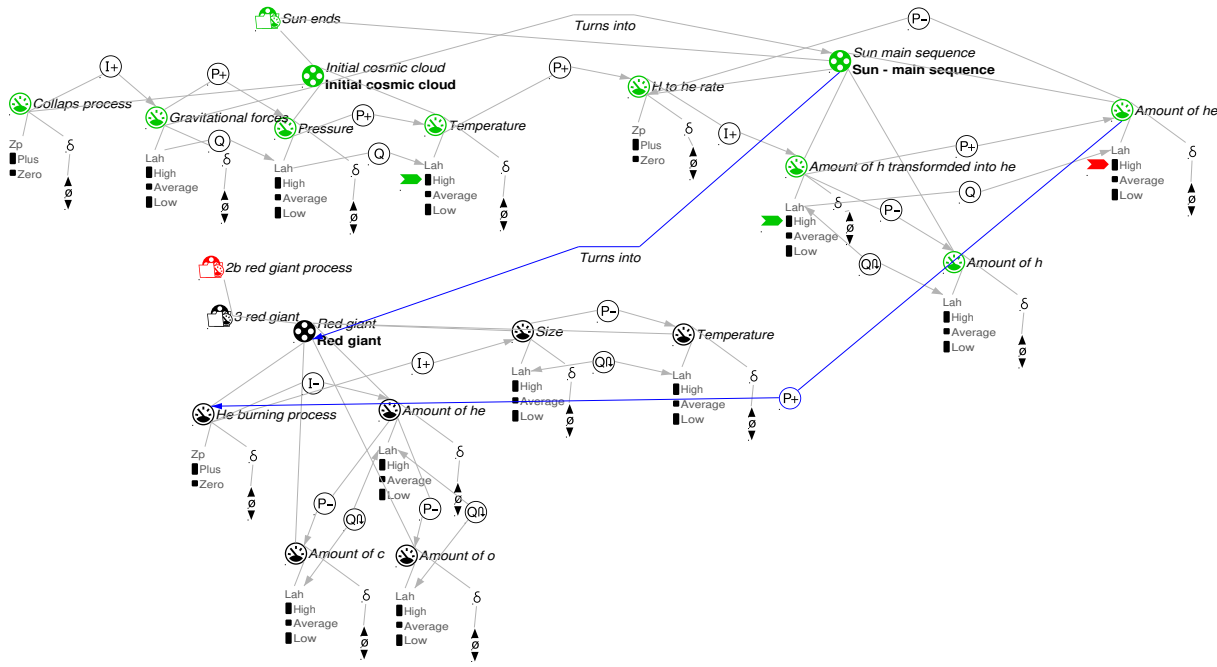

MF red giant ends: most of the He is burned and stops the red giant process

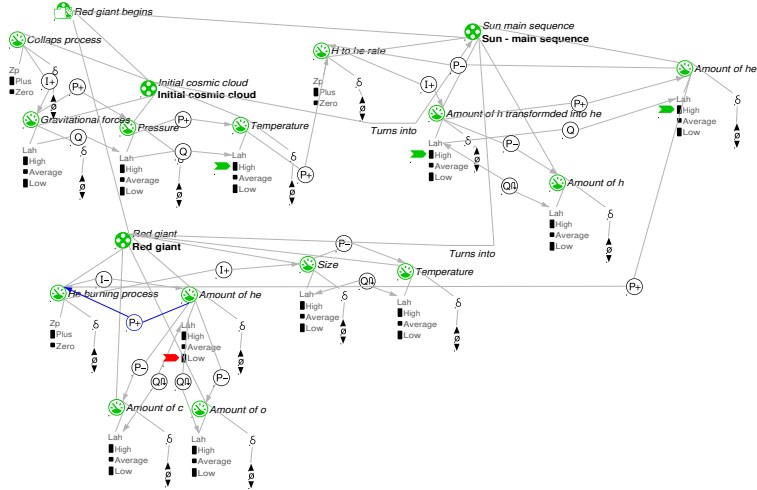

MF white dwarf develops: after a blow off of the outer layers, the core contracts and remains as white dwarf

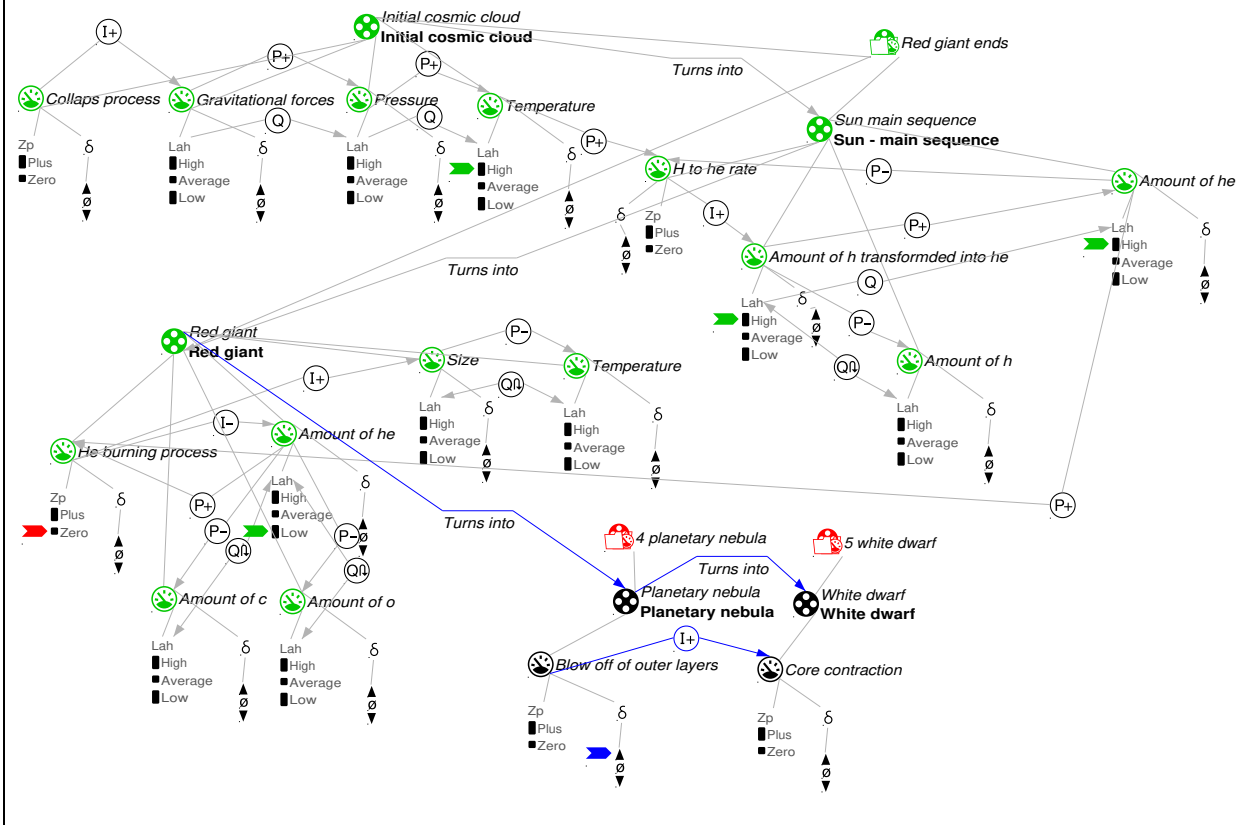

4.3.3 Scenarios and simulations

The scenario starts with the initial collaps process of a cosmic cloud, that starts the H to He fusion process, which is characteristic for the main sequence of the sun (Fig. 31).

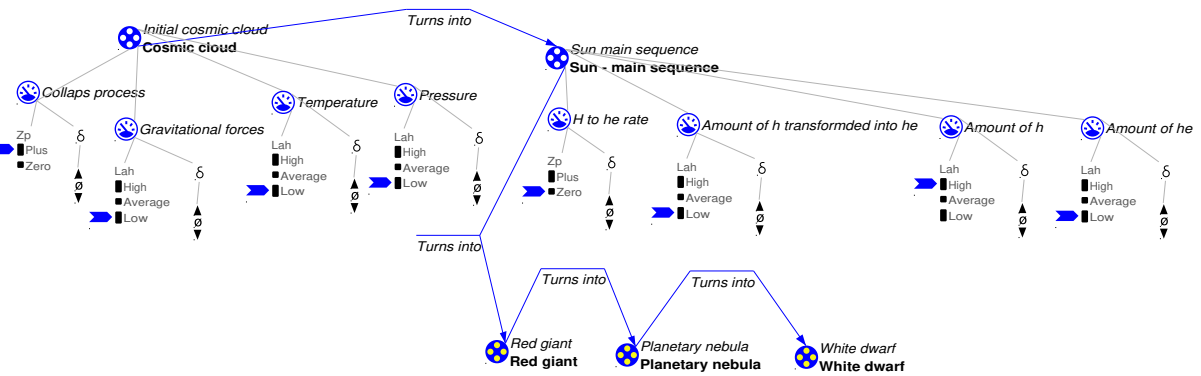

Figure 31: Initial part of the scenario of the model 'BOKU_sun evolution_LS6_advanced'.

The simulation yields 12 states with one end state (Fig. 32), which is the existence of the white dwarf (Fig. 33).

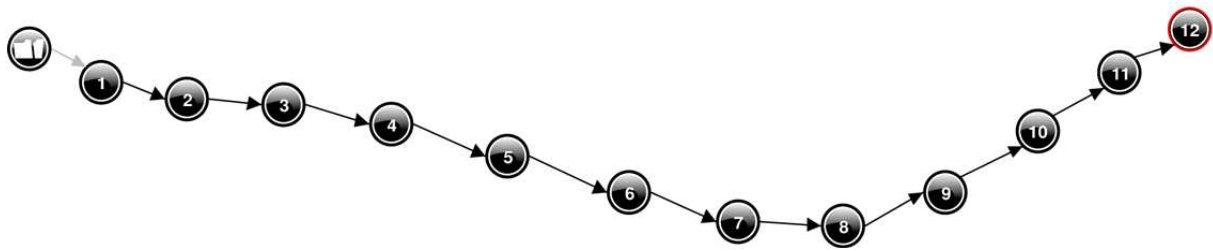
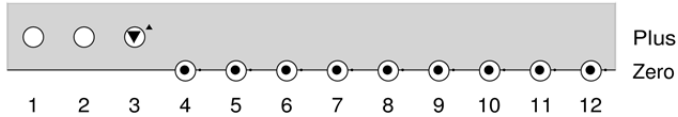
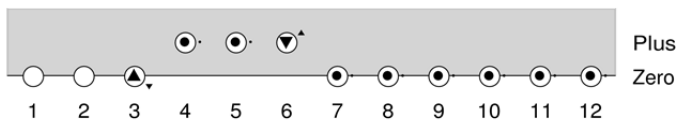

Figure 32: State graph of the model 'BOKU_sun evolution_LS6_advanced'.

Cosmic cloud: Collaps process



Sun - main sequence: H to he rate



Red giant: He burning process

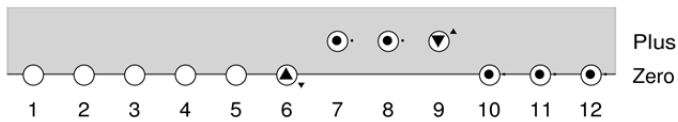

Planetary nebula: Blow off of outer layers

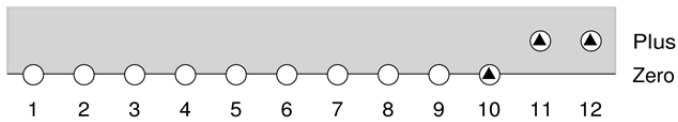

White dwarf: Core contraction

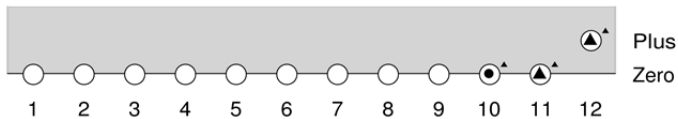

Figure 33: Value history of the model 'BOKU_sun evolution_LS6_advanced'.

4.3.4 Learning goals

4.3.4.1 Content

- The dominant processes during the life cycle of the sun
- The sun as major element of the creation of energy in our solar system
- Sun processes as basis for other elements in the universe
- Importance of the H to He fusion for any physical and biological process on earth
- Understanding the temporal limitation of any cosmic process according to the thermodynamic view

4.3.4.2 Modelling

- Compositional modelling
- Entity definition
- How to represent an evolution of different evolutionary phases, where each phase can be seen as one entity
- Use and arrangement of conditional statements
- Feedback loops

4.3.5 Assumptions and limitations

The model simulation does not remove the state variables after the process of a sun phase has ended; the focus was on the processes, which start and end according to the emerging properties during the sun evolution. The model ends with the core contraction of the white dwarf.

4.4 Evaporation

Topic	Natural processes forming riverine landscapes and habitats		
Author(s)	Andreas Zitek	Version(s)	DynaLearn 0.9.5(CM)
Model files	BOKU_LS6_evaporation_advanced.hgp		
Target users	Master students		

4.4.1 Topic summary

Although water, like all liquids, boils at a critical temperature, observation tells us that water can also be converted from liquid to vapour phases (i.e. it evaporates) at much lower temperatures. In fact all liquids (and solids) vaporize. The rate at which they do so depends on the nature of the substance, its temperature, its surface area and the conditions in the surrounding atmosphere.

Consider a closed container of liquid. The liquid molecules are in constant vibrational mode, i.e. they possess kinetic energy through this vibration. Energy is transferred from molecule to molecule when they collide. Molecules near the surface may thus attain sufficient energy to raise the clear of the liquid's surface (Fig. 32). In other words, such molecules have changed their state, from liquid to vapour. It follows that the greater the energy in the liquid, the more rapid will be the rate of change of molecules from liquid to vapour state: by applying more heat we can raise the rate of vaporization.

*The movement of molecules from liquid to vapour state is not one-way: molecules will also be returned to the water surface. Evaporation means that there is a **net movement** of molecules from liquid to vapour state. In our experiment this change of state increases the vapour pressure of the atmosphere, which is most readily appreciated in terms of the pressure exerted on the container's surface and the liquid surface.*

*In our enclosed container, evaporation will continue until the air can hold no more water. At this point the air is said to be saturated, and the pressure exerted by the vaporized water molecules is called the saturation vapour pressure. Although the reciprocal transfer of water molecules will continue at the saturation vapour pressure, there is no net transfer from liquid to the atmosphere: the system is in a state of a **dynamic equilibrium** (Fig. 32).*

Now if we raise the temperature of the container more, molecular movement increases, and once again there is a net transfer of molecules from liquid to vapour state, until a new dynamic equilibrium is established. This confirms what we know intuitively: water tends to evaporate more quickly in hot weather than in cold weather' (Bradbury et al., 2002).

Furthermore air movement is able to change the evaporation, mainly by the removal of vapour loaden air permitting a given vapour flux to be maintained (Thompson, 1998) (Fig. 32).

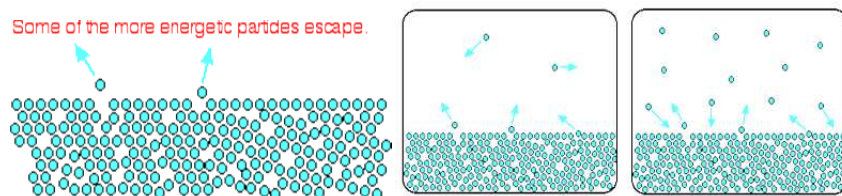

Figure 34: The principle of evaporation, water molecules with sufficient energy are able to leave the water surface; in a closed container a dynamic equilibrium can be reached, when there is no net transfer from liquid to the atmosphere, and the amount of molecules leaving equals the amount of molecules re-entering the liquid.²⁴

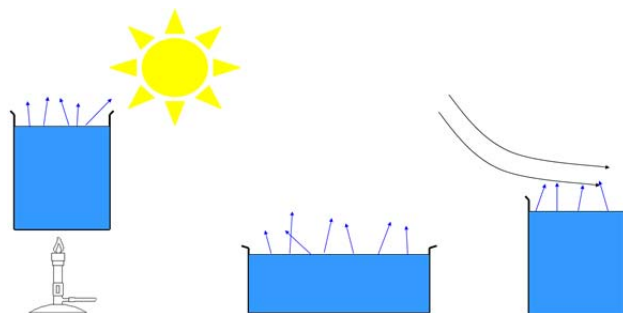

Figure 35: Some ways to increase the evaporation: adding heat energy that increases the kinetic energy of the water molecules, increasing the water surface area and removal of saturated air above the water surface by air movement.²⁵

Tab. 9 contains the main entities and quantities identified as being relevant for the evaporation process.

Table 9: Entities, quantities and quantity spaces (QSs) used in the model 'BOKU_sun evolution_LS6_advanced'.

Entity	Quantities	QS	Remarks
Pan	Diameter	lah	low, average, high
	Surface area	lah	low, average, high
Water	Amount of	lah	low, average, high
	Amount of molecules leaving	lah	low, average, high
	Amount of molecules falling back	lah	low, average, high
	Molecular movement	zp	zero, plus
	Net evaporation rate	mzp	minus, zero, plus
Air	Vapour saturation	lah	low, average, high
	Air transport rate	zp	zero, plus
Sun			
Radiation	Infrared	zp	zero, plus

²⁴ <http://www.chemguide.co.uk/physical/phaseseqia/vapourpress.html>

²⁵ <http://mrsimonporter.wikispaces.com/IB+Physics+Year+12>

4.4.2 Model expression

4.4.2.1 Entity hierarchy

The model 'BOKU_LS6 evaporation_advanced' contains 5 entities that are hierarchically linked by configurations (Fig. 36).

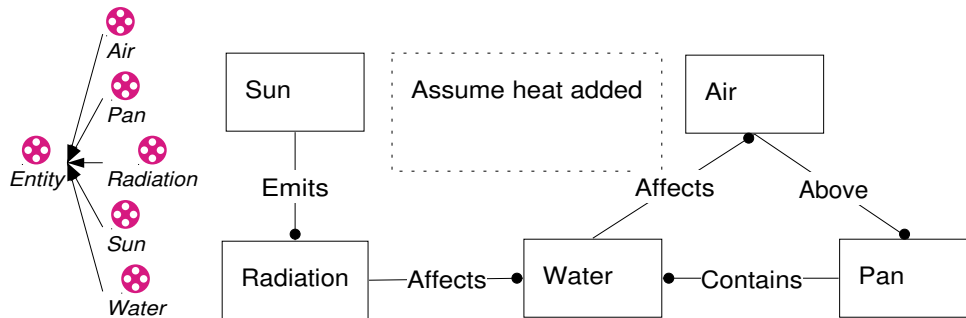

Figure 36: Entity hierarchy of the model 'BOKU_LS6 evaporation_advanced', and example of an entity configuration of a scenario where heat is added by sun radiation.

4.4.2.2 Model fragment hierarchy

The model consists of 4 process model fragments (Fig. 37). Each represents a different scenario.

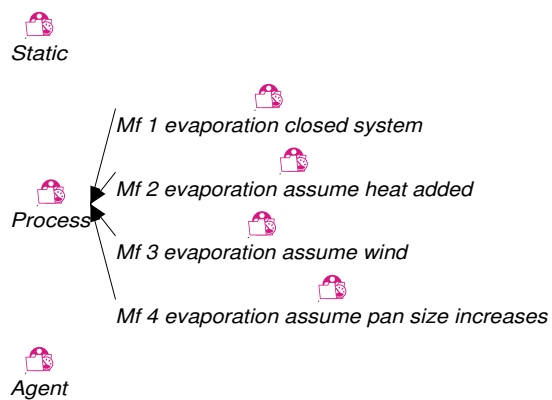

Figure 37: Model fragment hierarchy of the model 'BOKU_LS6 evaporation_advanced'.

4.4.2.3 Model fragments

The model consists out of 4 process model fragments representing different scenarios:

- 1) In a closed system the molecular movement of water molecules leads to water molecules leaving the system (Fig. 38). From the relationship between the molecules leaving and the molecules falling back, the net evaporation is calculated. The net evaporation rate is linked via an influence to the vapour saturation of the air. Given the 'Amount of molecules falling back' equals the 'Amount of molecules leaving', the 'Net evaporation rate' is set to zero yielding a dynamic equilibrium at the saturation vapour pressure.

- 2) In Fig. 39 a situation is described, where 'Infrared' radiation emitted by the sun positively influences the 'Molecular movement' of water molecules. This has a positive effect on the 'Amount of molecules leaving' the water. As the constant and increasing influence of heat energy also increases saturation vapour pressure, it is expected that no dynamic equilibrium is reached with the given model structure.
- 3) Fig. 40 shows a situation of an open system, where an 'Air transport rate' above the pan (wind) has a negative influence of the 'Vapour saturation' of air (by removing the saturated air and exchanging it with unsaturated air). No dynamic equilibrium is expected.
- 4) Finally Fig.41 shows the positive effect of an increased pan 'Diameter' and the associated increase of the 'Surface area' on the 'Amount of molecules leaving'. Given an active 'Air transport rate', no dynamic equilibrium is expected. The directed correspondence between 'Molecular movement' and 'Amount of molecules leaving' is removed, as the change in 'Surface area' is considered as main factor, and therefore linked to the 'Amount of molecules leaving' by a directed correspondence instead.

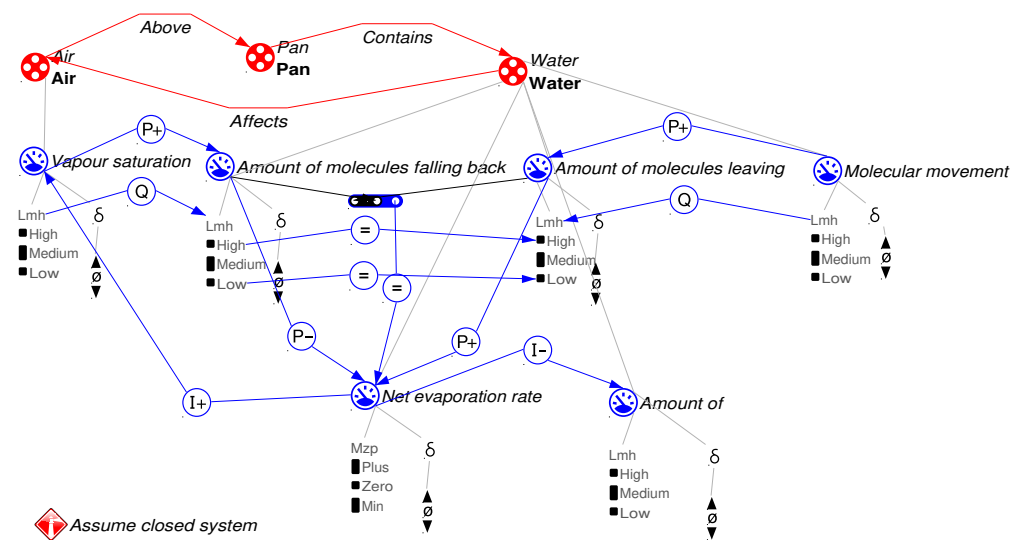

Figure 38: Model fragment 'Mf 1 evaporation closed system of the model' of the model 'BOKU_LS6 evaporation_advanced'.

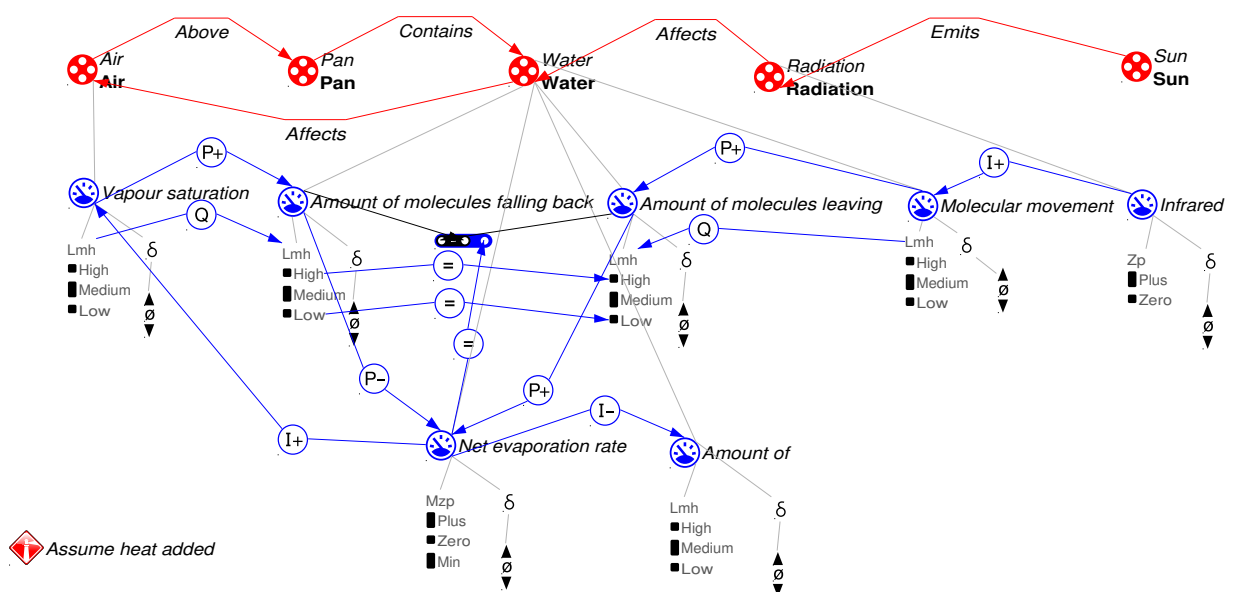

Figure 39: Model fragment 'Mf 2 evaporation assume heat added' of the model 'BOKU_LS6 evaporation_advanced'.

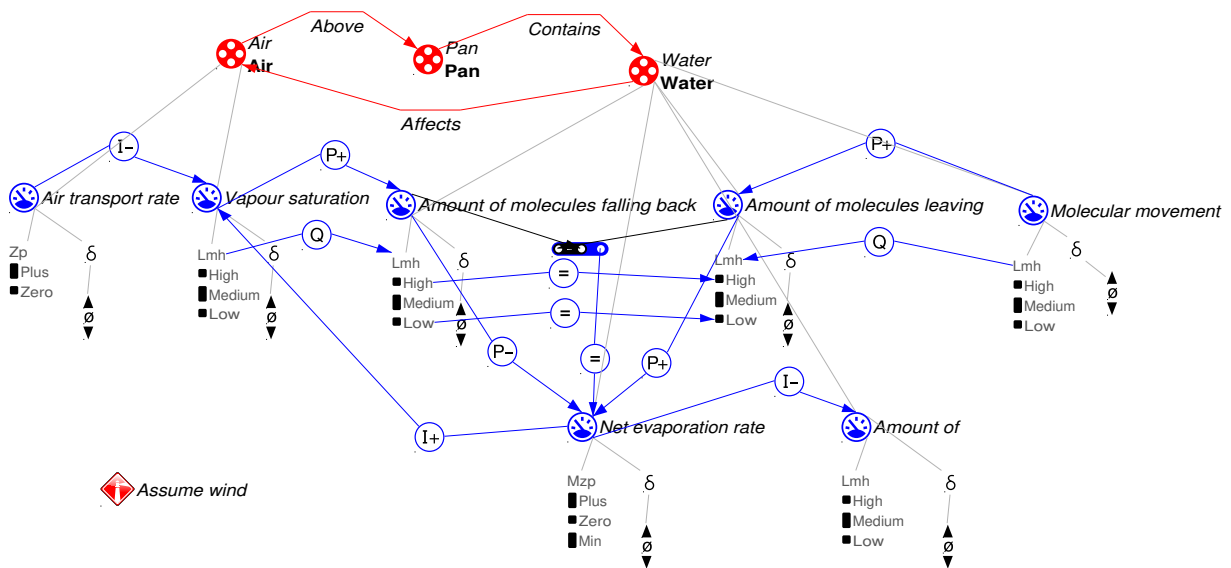

Figure 40: Model fragment 'Mf 3 evaporation assume wind' of the model 'BOKU_LS6 evaporation_advanced'.

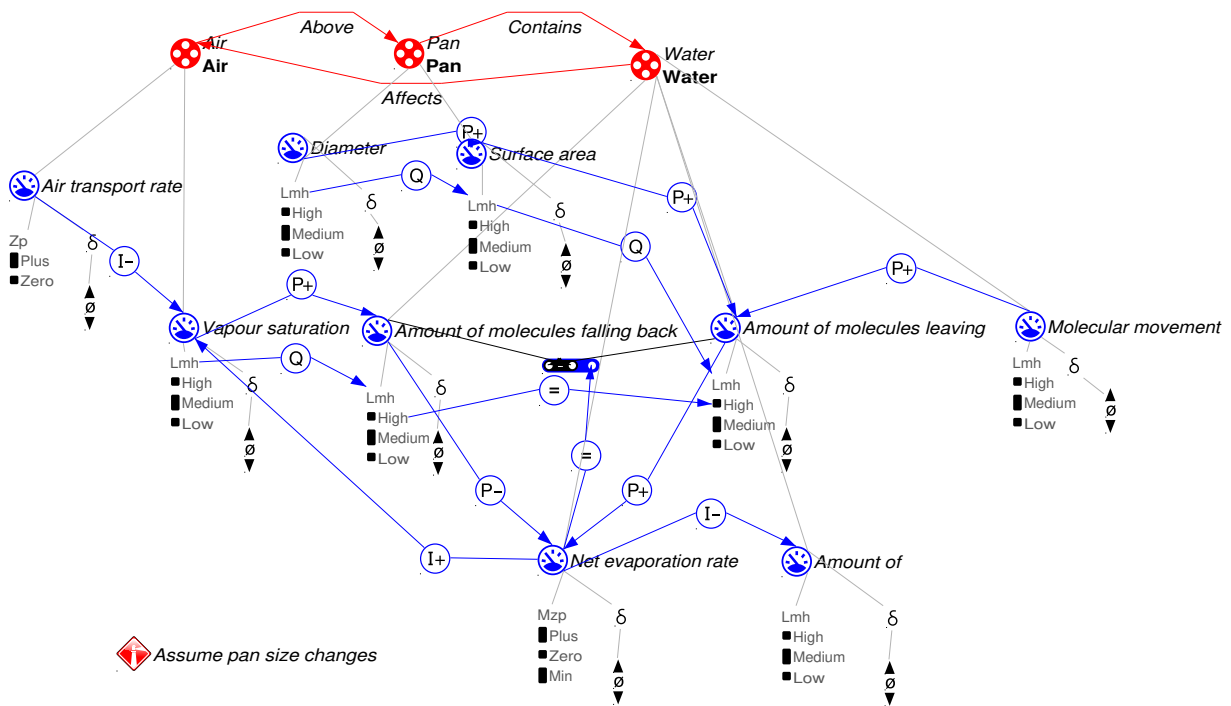

Figure 41: Model fragment 'Mf 4 evaporation assume pan size increases' of the model 'BOKU_LS6 evaporation_advanced'.

4.4.3 Scenarios and simulations

4.4.3.1 Sc1 evaporation closed system

The situation described represents a closed system. The initial situation is characterized by a high 'Amount of molecules leaving' the water, which is caused by high 'Molecular movement' as an expression of temperature and the kinetic energy of the molecules (Fig. 42). 'Amount of molecules falling back' and 'Vapour saturation' are at a medium level. The simulation yields three end states (Fig. 43, left), of which two represent a dynamic

equilibrium, where the 'Amount of molecules leaving' and the 'Amount of molecules falling back' are equal, which sets the net evaporation rate to zero. Fig. 43 (right side) shows one selected state graph describing the increase of the 'Vapour saturation' of the air finally reaching the equilibrium at the vapour saturation pressure.

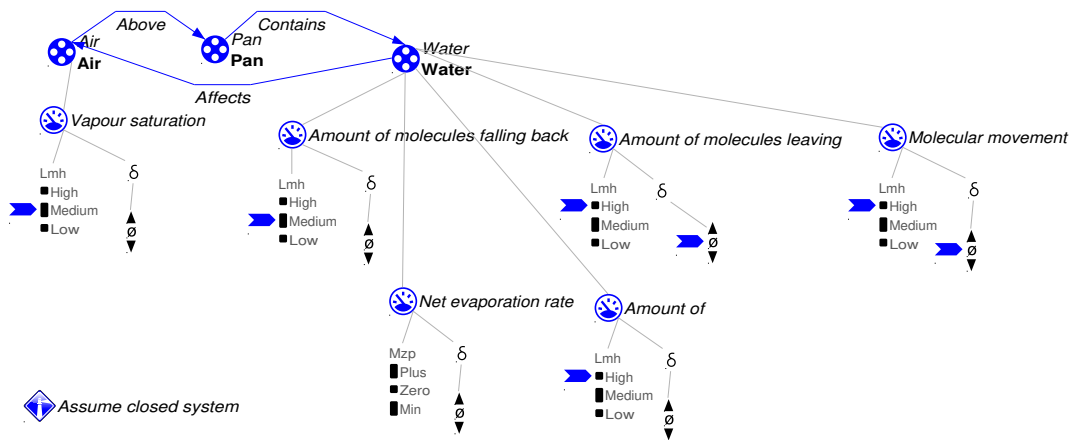

Figure 42: 'Sc1 evaporation closed system' of the model 'BOKU_LS6 evaporation_advanced'.

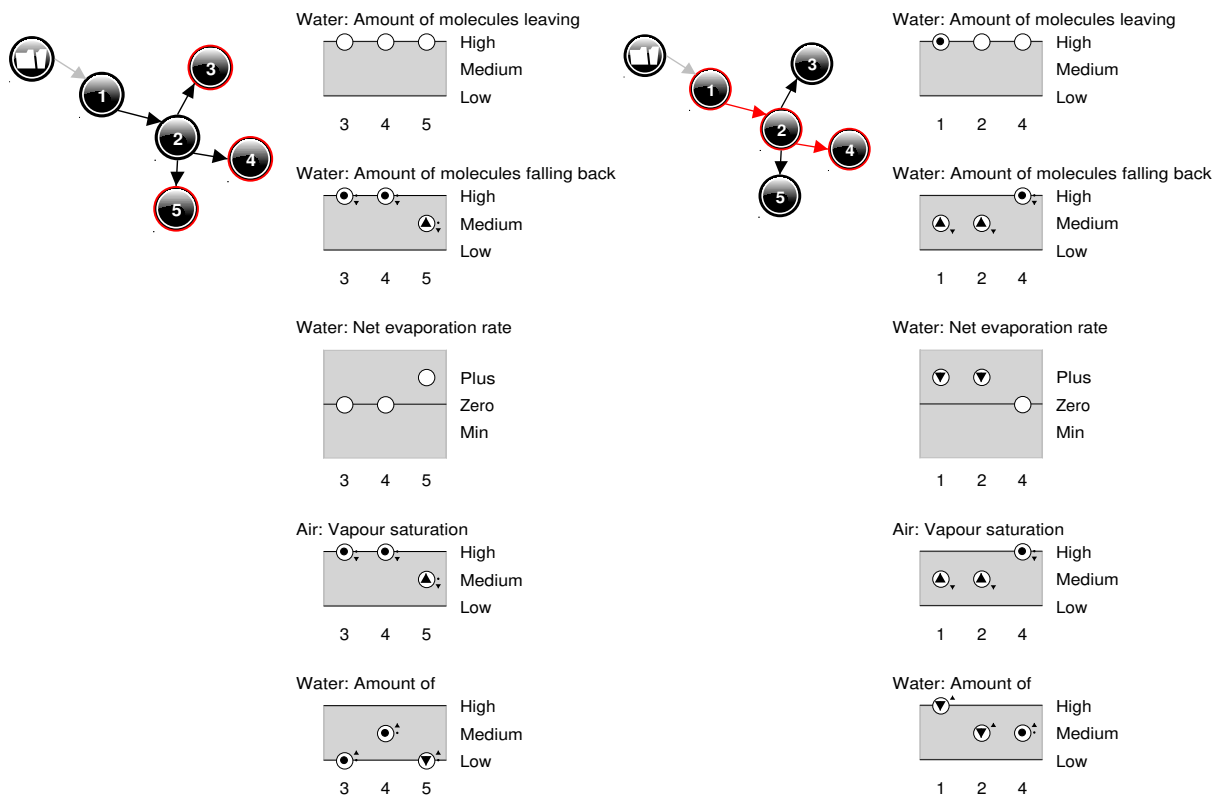

Figure 43: End states (left) and one selected simulation state graph (right) with its associated value history (right) of the 'Sc1 evaporation closed system' of the model 'BOKU_LS6 evaporation_advanced'.

4.4.3.2 Sc2 evaporation assume heat added

The simulation starts at an equilibrium situation (Fig. 44). Due to the increase of 'Molecular movement' caused by an increase of 'Infrared' radiation the vapour saturation pressure changes and again more molecules are able to leave the water.

The simulation yields two end states (Fig. 45). In both end states, the 'Amount of molecules leaving' is high and increasing whereas the 'Amount of molecules falling back' is staying at medium and increasing. This in principle reflects the idea that adding energy to the system shifts the saturation vapour pressure as more water molecules are allowed to leave the water under the given circumstances; the constant increase of energy delivery to the system does not allow for an equilibrium to be established. Fig. 46 shows a selected state graph with its associated value history.

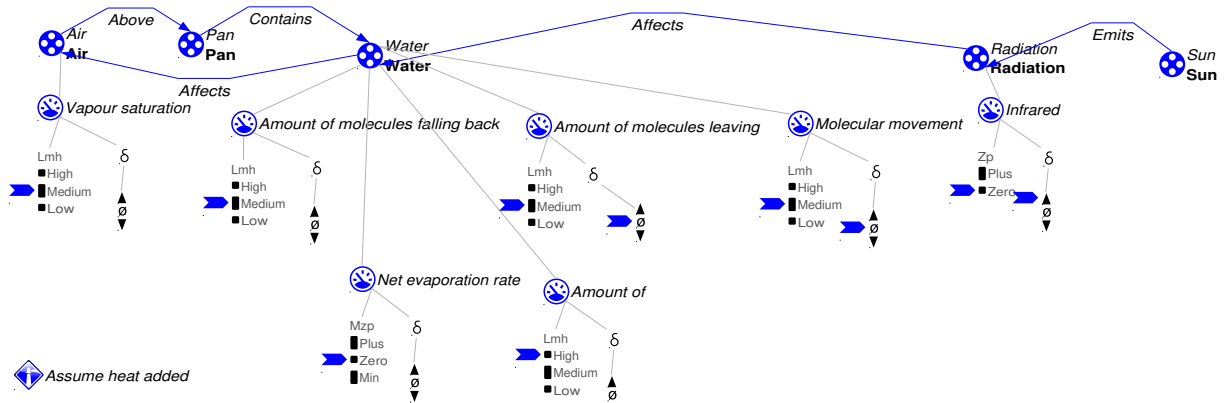

Figure 44: 'Sc2 evaporation assume heat added' of the model 'BOKU_LS6 evaporation_advanced'.

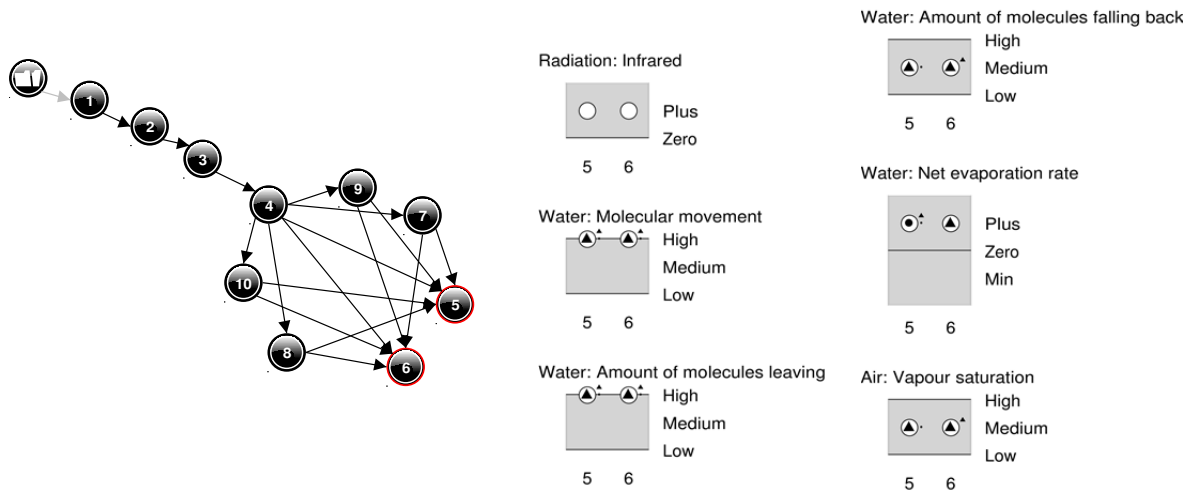

Figure 45: End states with their associated values of the 'Sc2 evaporation assume heat added' of the model 'BOKU_LS6 evaporation_advanced'.

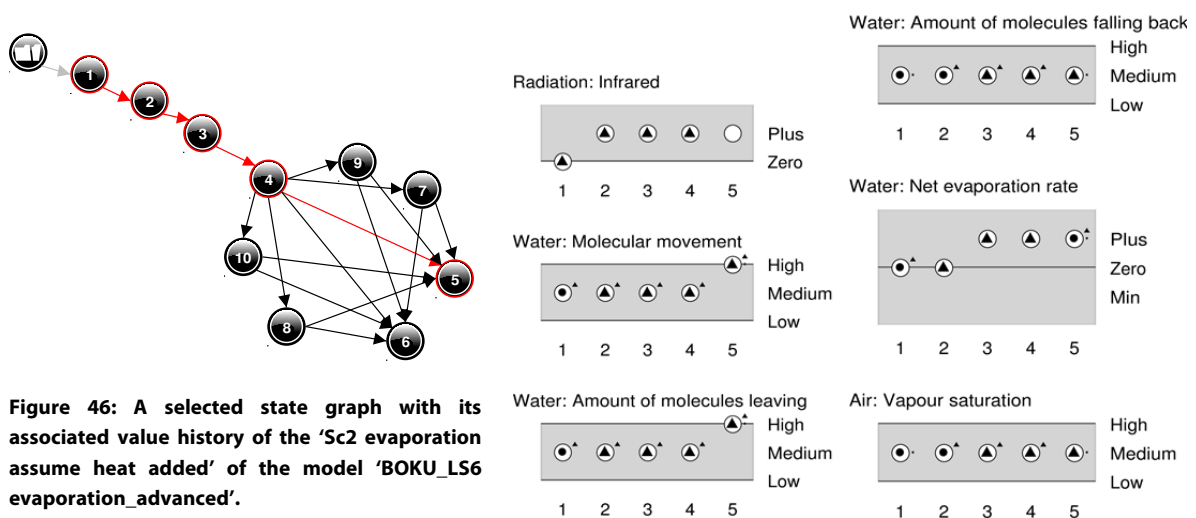

Figure 46: A selected state graph with its associated value history of the 'Sc2 evaporation assume heat added' of the model 'BOKU_LS6 evaporation_advanced'.

4.4.3.3 Sc3 evaporation assume wind

This simulation introduces the effect of air transport on the vapour saturation of air in natural situations. The initial situation is an assumed equilibrium situation above the surface of a pan (Fig. 47).

The simulation yields 4 end states (Fig. 48). Due to constant air transport no equilibrium is achieved.

The increase of air transport reduces the vapour saturation above the pan by removing saturated air and delivering unsaturated air. The 'Amount of' water in the pan keeps to decrease because of the positive 'Net evaporation rate' (Fig. 49).

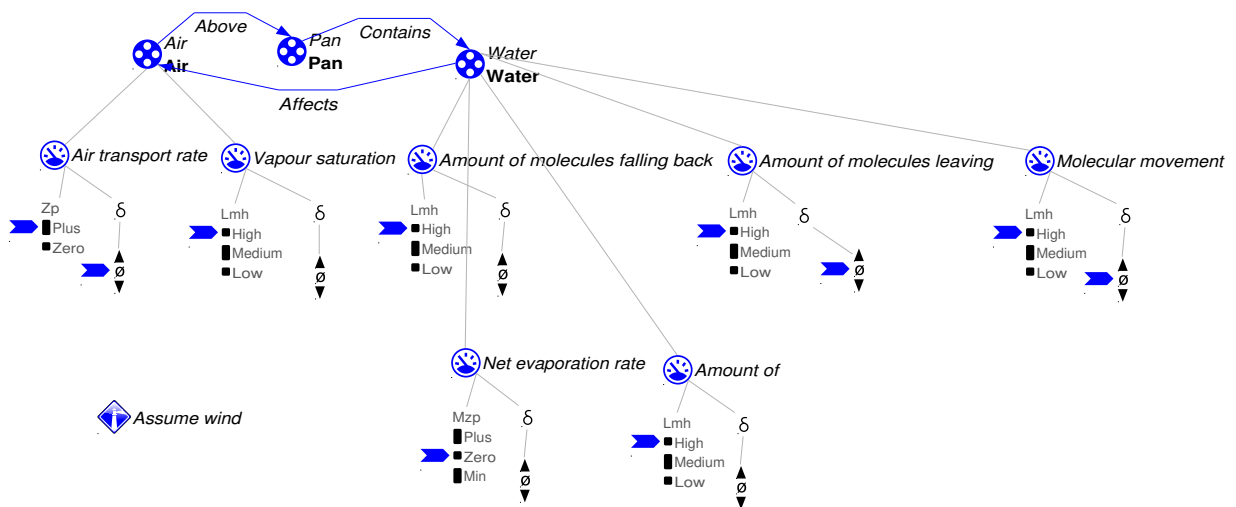

Figure 47: 'Sc3 evaporation assume wind' of the model 'BOKU_LS6 evaporation_advanced'.

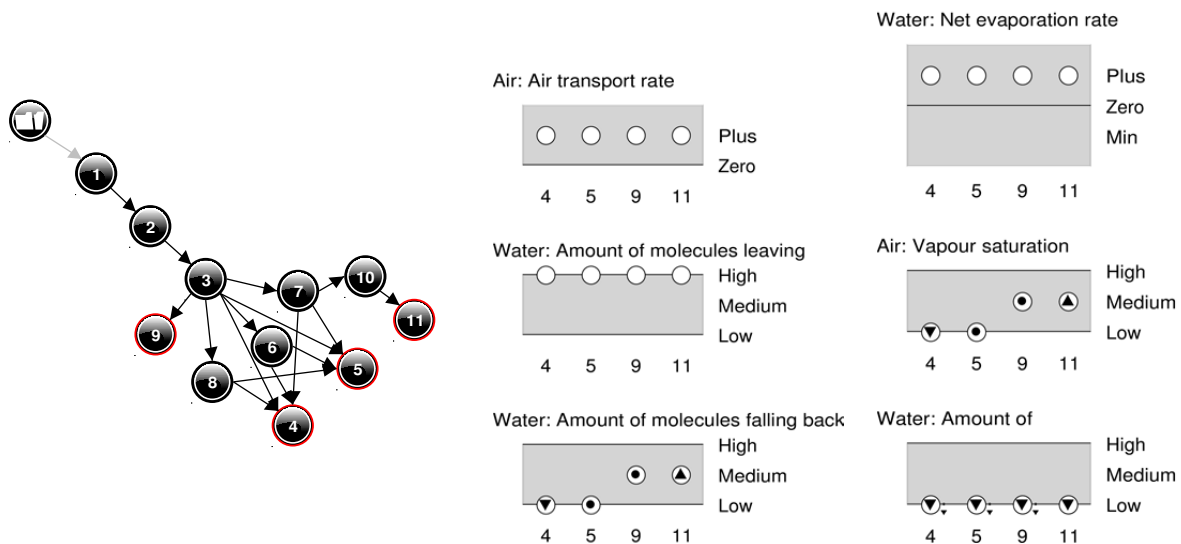

Figure 48: End states with their associated values of the 'Sc3 evaporation assume wind' of the model 'BOKU_LS6 evaporation_advanced'.

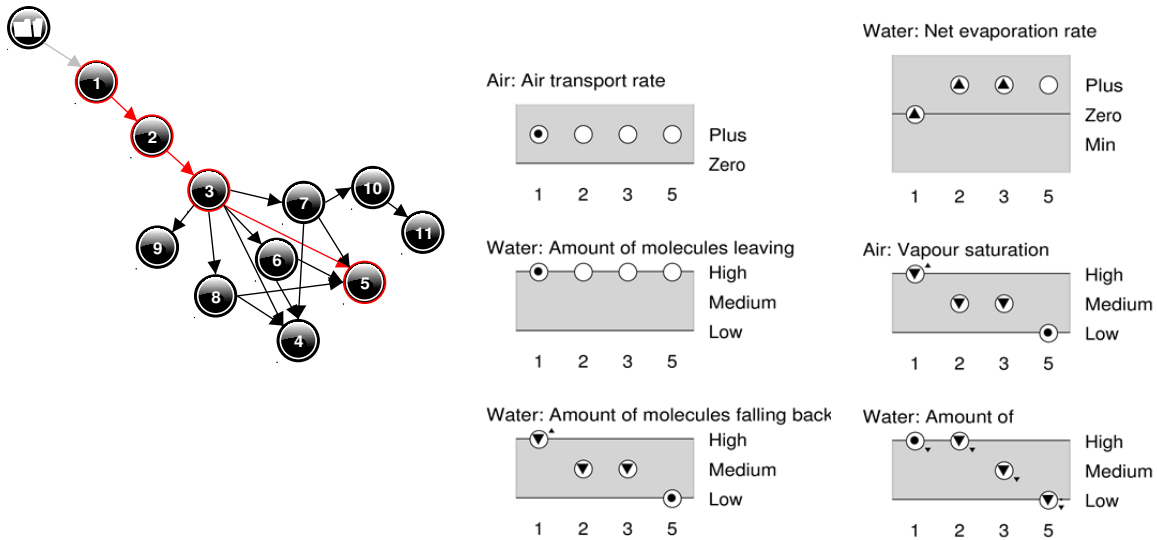

Figure 49: A selected state graph with its associated value history of the 'Sc3 evaporation assume wind' of the model 'BOKU_LS6 evaporation_advanced'.

4.4.3.4 Sc4 evaporation assume pan size increases

This scenario aims at the introduction of the effect of an increased water surface on the amount of water molecules able to leave the water by evaporation. It must be noted that an increased surface might affect the 'Amount of molecules' leaving, but not the vapour saturation pressure. Vapour saturation pressure can only be changed by temperature. This means, that an existing equilibrium within a closed system cannot be changed by changing the 'Surface area'. Depending on the level of 'Vapour saturation' of the air and the 'Amount of molecules falling back', only a limited 'Amount of molecules leaving' is possible when temperature and volume of air above the pan remain constant.

In this scenario, the situation starts at a low 'Amount of molecules leaving' and a low 'Amount of molecules falling back' (Fig. 50). The definition of an inequality statement between these two variables prevents the development of an equilibrium. The 'Molecular movement' is low and stable, with an additional activation of the 'Constant' option in the properties of this quantity (called 'Advanced quantity behaviour'). Also the air transport is active. Without any other change the 'Amount of molecules leaving' would stay at low, although the vapour saturation would increase due to the inequality statement, followed by an increase of 'Amount of molecules falling back'. Equilibrium is prevented by the constant 'Air transport rate'. The simulation yields 4 end states, without an equilibrium state occurring (Fig. 51). Due to the increase of 'Surface area', 'Amount of water molecules leaving' increases (Fig. 52), and 'Amount of' water in the pan decreases quicker.

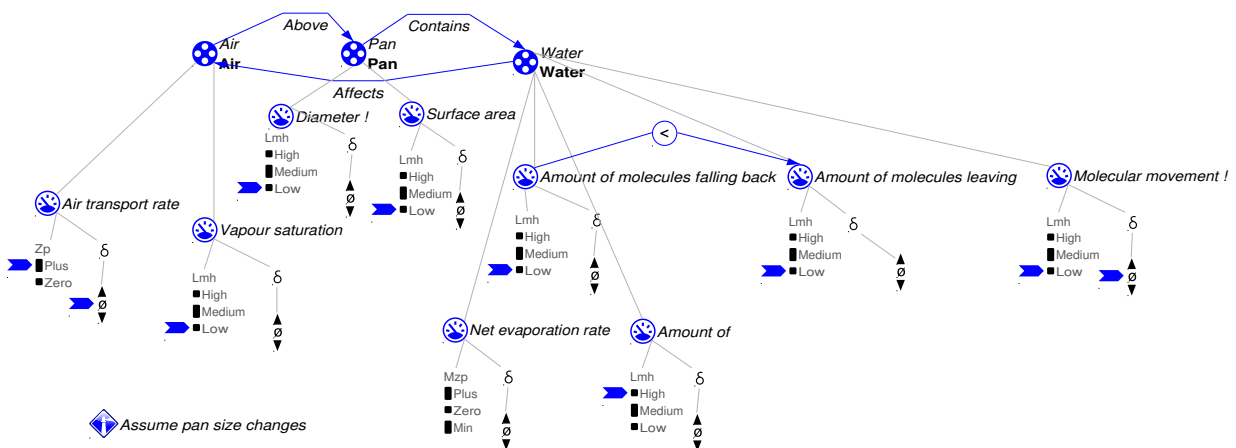

Figure 50: 'Sc4 evaporation assume pan size increases' of the model 'BOKU_LS6 evaporation_advanced'.

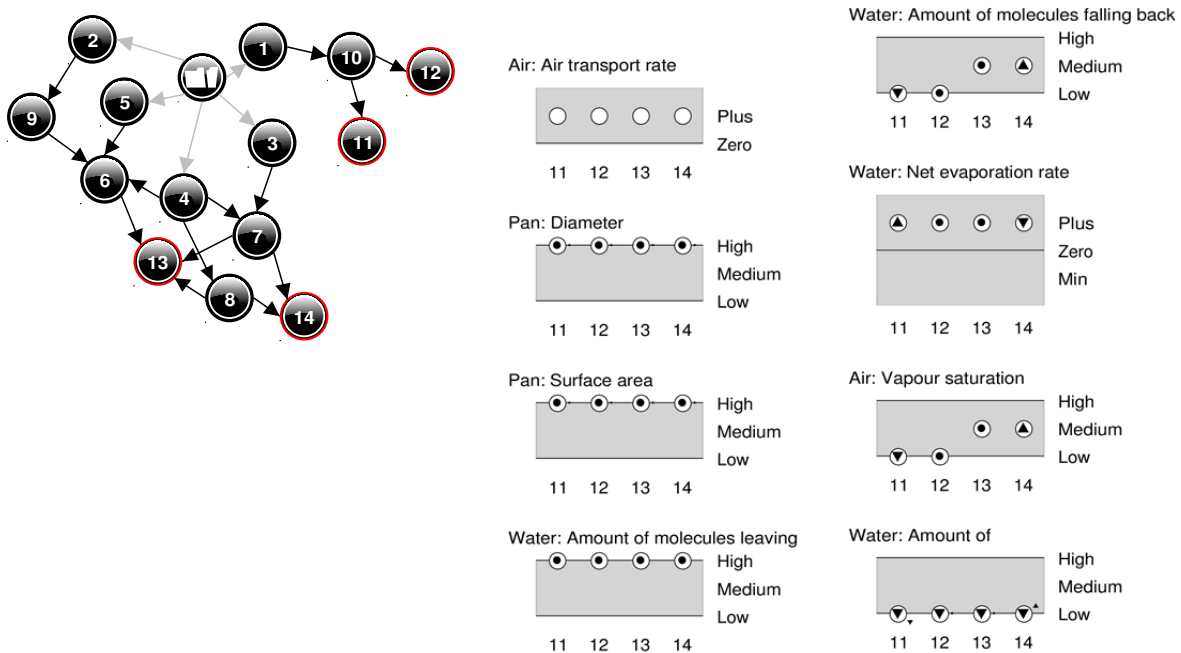

Figure 51: End states with their associated values of the 'Sc4 evaporation assume pan size increases' of the model 'BOKU_LS6 evaporation_advanced'.

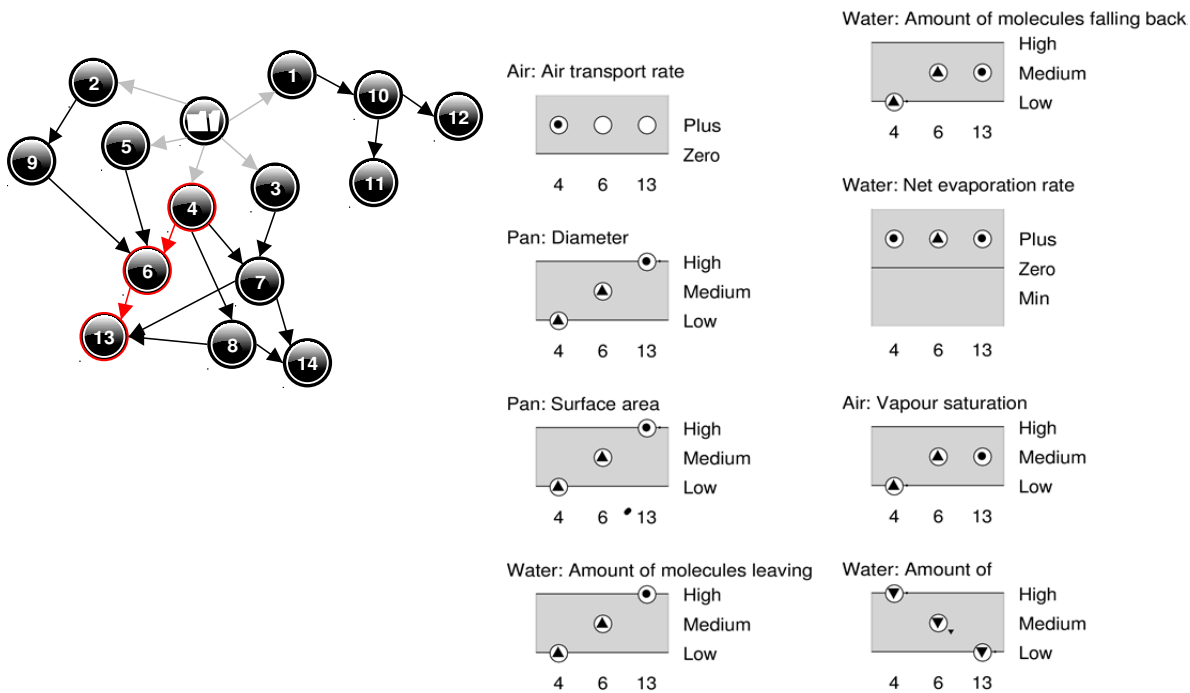

Figure 52: A selected state graph with its associated value history of the 'Sc4 evaporation assume pan size increases' of the model 'BOKU_LS6 evaporation_advanced'.

4.4.4 Learning goals

4.4.4.1 Content

- Nature of evaporation
- Factors affecting evaporation
- Vapour pressure and saturation vapour pressure
- Identification of different possible states of a system
- Relevance of evaporation for the full hydrological cycle

4.4.4.2 Modelling

- Creating a net rate based on a calculus between two variables
- Creation of a feedback loop
- Modelling a dynamic equilibrium expressed as zero net movement
- Advanced use of quantity spaces
- Development of scenarios
- Setting the adequate starting values in scenarios
- Using inequality statements in scenarios
- Interpretation of state graphs

4.4.5 Assumptions and limitations

From a conceptual point of view some additional quantities could be added without changing the simulation behaviour; e.g. an 'Amount of water molecules in the air', that could be linked to the existing quantity 'Vapour saturation' via a direct correspondence would add some more explanatory detail. But in principle the model structure, especially the feedback loop from the rate via an intermediate quantity to the 'Amount of molecules falling back' can be seen as a generic and powerful modelling pattern that is applicable to many situations.

The main problems occurred during the definition of the initial values of the different scenarios. For example in Scenario 4, where the increase of 'Surface area' leads to an increase of 'Amount of molecules leaving', the 'Molecular movement' was set to 'low' and the derivative was set to 'stable'. But the desired behaviour of the simulation was only derived, when the 'Constant' button in the advanced quantity behaviour settings (can be found under properties of a quantity) was activated. It is not clear, what the difference between 'stable' and 'constant' is, and how this difference influences the simulation.



Figure 53: Only activating the 'constant' button in the properties of the quantity 'Molecular movement' in 'Sc4 evaporation assume pan size increases' yielded the desired simulation behaviour; defining the quantity value as 'low' and the derivative as 'stable' seems not to be the same.

In general, most settings of the initial values within the scenarios to get the desired simulation path were derived by trial and error. Especially the combination of the different quantity space values and their associated derivatives had a strong impact on the simulation. E.g. it was not clear why only setting the 'Air transport rate' in the scenario 'Sc3 evaporation assume wind' to 'plus' and 'stable' yielded the desired behaviour, whereas setting the air transport to 'zero' and 'increasing' yielded only two states (Fig. 54).

In addition it was a challenge to determine the adequate quantity spaces, because their interaction significantly influences the simulation behaviour. This was also done by trial and error.

Finally, it seems impossible for a non-QR expert, to understand what is going on behind the scene with regard to these issues. Therefore in our opinion an advanced guidance at LS 6 especially for setting initial values for simulations and the selection of adequate quantity spaces (e.g. best choices to be used for calculations; using zero or no zero within a quantity space etc.) with detailed explanations on the effect of the different choices on simulation behaviour is needed. To a certain extend this also applies to LS 5, where also initial values have to be defined within an extra model fragment.

In general, all simulations were run without changing the simulation preferences, although the number of states could be reduced in some cases when activating the 'Apply fastest path heuristic' option and/or deactivating the 'Apply epsilon ordering' and 'Apply epsilon derivative continuity constraints' options.

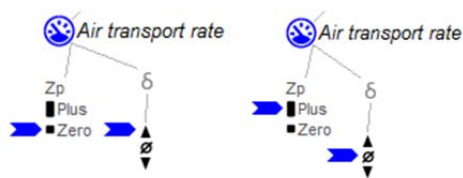

Figure 54: Only setting the air transport rate to 'plus' and 'stable' in 'Sc3 evaporation assume wind' yielded the desired behaviour, whereas setting the air transport to 'zero' and 'increasing' yielded only two states; it was expected that in the second case, after the air transport rate is set to plus, the simulation develops in a similar way.

Although the simulation of 'Sc4 evaporation assume pan size increases' yields the desired behaviour in the current configuration, the causal model might need further elaboration, as there still seem to be conflicting issues, when the 'Air transport rate' is removed.

5. Suggestions for the development of a modelling framework

Modelling can be considered as a very advanced and complex cognitive process (Jonassen and Strobel, 2006) needing adequate scaffolding (Sins et al., 2005).

In our opinion, learning conceptual knowledge with DL only can make a difference in education, when it is clearly linked to other powerful and scientifically accepted frameworks to deconstruct complexity. We have introduced hierarchy theory and the thermodynamic viewpoint.

For the GARP3 software, an overall modelling framework has been developed (Bredeweg et al., 2008). The most comprehensive overview of typical modelling problems and mistakes along with suggestions of a good modelling practice is given by Grant and Swannack (2008).

Determination of where to start and end a modelling activity, which is related to the determination of the model's boundary, is known to be a difficult task (Serman, 2000). It is known, that on a content level especially novice modellers have problems to with identifying the relevant variables and to order and interlink them in the right and dynamic way (Jonassen and Strobel, 2006; Meadows, 2008; Sins et al., 2005). Typical problems occur with regard to the consideration of change of factors over time, time dependence of variables, the consideration of multiple processes, side effects, feedback loops (Diehl and Serman, 1995; Jonassen and Strobel, 2006; Sins et al., 2005) and with understanding non-linear relationships, keeping the entire system in mind while working on a component (Clariana and Strobel, 2008). It is also known, that specific problems occur with the identification and inclusion of flows (rates) in student models (Clariana and Strobel, 2008; Sins et al., 2005), while students mixing up processes and static variables (Clariana and Strobel, 2008). It seems that the human mind tends to focus more easily on stocks than on flows, with a tendency to focus on inflows more easily than on outflows (Meadows, 2008). On a more generic level it seems that is even not easy for novice modellers to distinguish between quantities and entities (Zitek et al., unpublished data). Sometimes, students might have problems to detect mismatches between model behaviour and the expected and intended results (Sins et al., 2005). Finally sometimes, students might not understand the meaning and value of the modelling activity (Sins et al., 2005), why it is crucial to introduce modelling as meaningful tasks within an authentic context (Jonassen and Strobel, 2006).

Summarizing, some of the main problems that novice modellers might have, are

- Identification of relevant variables in a system
- Setting the model boundary
- Determination of quantities and entities
- Identification and representing flows/rates
- Identification of feedback loops, delays and non-linear effects
- Realization of side effects
- Developing a simple and clear model structure, that could be transferred to other problems
- Evaluating the outcome and behaviour of a model
- General difficulties in understanding the reason for the modelling activity

Therefore a clear scaffolding strategy needs to be developed, where and how to start the modelling process, and how to progress to develop higher modelling skills (Clariana and Strobel, 2008).

For example, it makes sense to develop model building assignments related to different Learning Spaces according to the expertise in model building and the level of performance of the target group. For this purpose we developed a simple three-dimensional competence matrix (Fig. 55). It is based on a 3-dimensional competence model developed for environmental education in Austria (Faissner et al., 2010).

The dimensions describe the progression from a novice modeller to an experienced ecosystem modeller with DL. The level of performance (modelling skill) dimension develops from strongly guided activity using simple vocabulary, exploration & reproduction modus, over simple model building and better understanding of vocabulary in the autonomous and reproduction modus, using domain vocabulary (grounding, feedback) to the autonomous model building mode, interdisciplinary application and transfer of generic scientific modelling concepts (thermodynamics, hierarchy...), selection of appropriate model complexity.

The competence of (problem related) acting dimension goes from model interpretation and understanding (of structure and relations), to hypotheses formulation and simulation/prediction (understanding the implications of the relations) and finally to the consciousness development of scenarios, application of DL to solve a specific (learning/scientific) problem, with selection and discussion of the best solution with the ability to judge the model potential and its limitations.

The software complexity dimension follows the Learning Space (LS) structure of DL, and goes from simple representation of elements and structures towards causal relations, representation of rates and state variables to complex systems.

Four examples shown in Fig. 55 illustrate the idea of a competence based task development:

1. A task with the code LS 1-A-niv 1 is dealing only with elements and structure, conducted using the model exploration or reproduction mode and is strongly guided at LS 1.
2. A task with the code LS 2-B-niv 2 is dealing with causal relationships, targeting at the development of a hypotheses, prediction and simulation, partly autonomous and partly reproducing, using domain vocabulary together with grounding and feedback from a repository.
3. A task with a code LS 4-C-niv 3 deals with processes and system states (LS4), requiring the development of scenarios, and a deep understanding of the limitations and potential of the model and the determination and explanation of potential outcomes together with a highly autonomous interdisciplinary application of generic modelling patterns.
4. A task coded LS 6-A-niv 1 deals with a complex system, with strongly guided activity using simple vocabulary only in an exploration mode. It can be expected that in many classroom situations the use of LS 6 models will be restricted to this mode.

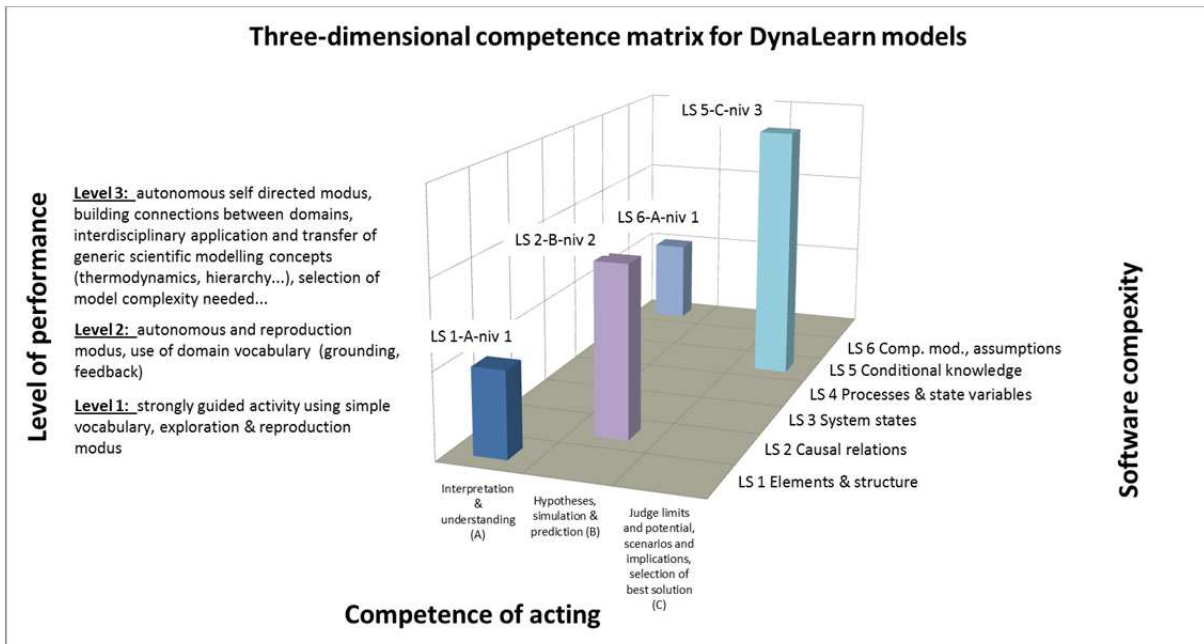

Figure 55: Application of the competence scheme to the DynaLearn software with coding of different competences integrated within a task.

A basic understanding which features and elements are available in DL to capture system elements and structure and dynamics is crucial for any model building activity using DL. They need to be introduced in a clear and understandable manner by the instructor together with a general framework on model building, pointing out the value of the conceptual model building exercise. Fig. 56 shows which different types of modelling, based on different modelling languages, are used by humans to develop a scientific understanding of reality on Earth.

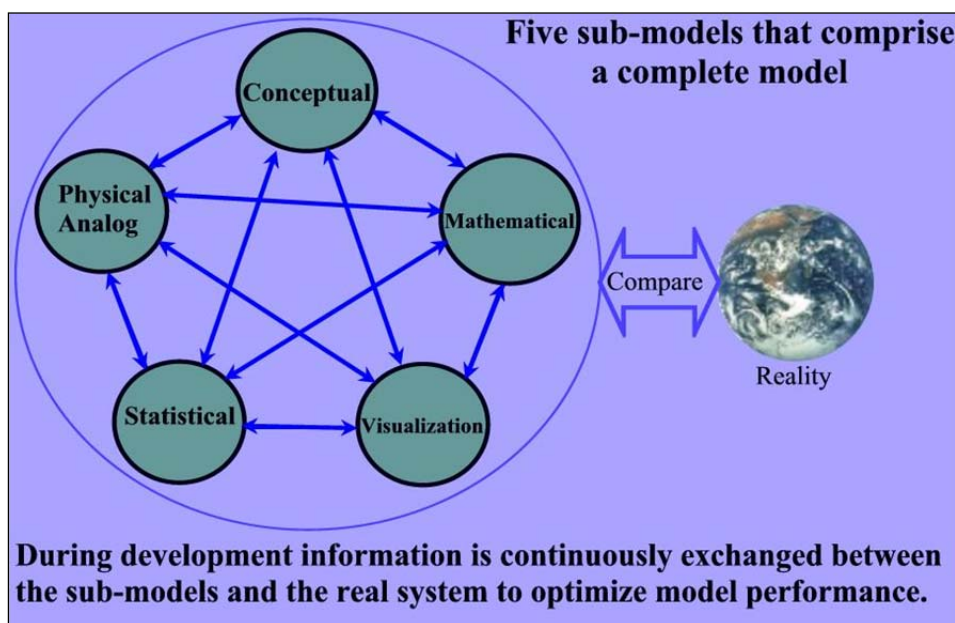

Figure 56: Conceptual models in combination with other different scientific models contribute to a comprehensive understanding of any scientific issue; scientific modelling is the process of generating abstract, conceptual, graphical and/or mathematical models; each of these methods can be characterized by a specific modelling language used to express information or knowledge or systems in a structure that is defined by a consistent set of rules.²⁶

²⁶ <http://sahet.net/htm/swdev11.html>

To start the modelling Ahl and Allen (1996) e.g. recommend to *'freeze part of the flux by giving definitions to repeated patterns of experiences involving the main properties of the system that we are interested in'*. This involves as a first the selection of a system that we want to model. They also point out the necessity to make the distinction between definitional criteria/entities (postulated before a measurement/observation is made) and empirical criteria/entities (the criteria found after the measurement/observation). This is being considered as important, *'as often the contribution of the observer to the observed is forgotten, taking the definitional criteria for real. Definitions and criteria/entities are not discovered in nature; instead they are product of the observer and his/her interpretation of perception. These criteria and patterns give structure to experience and are modified to facilitate assimilating new experiences into existing cognitive models (the observer's web of belief). A different interaction would produce a different set of things'* (Ahl and Allen 1996).

In most cases it is a good starting point to think about which type of material or which environmental variable is of core interest, and to identify the rate that changes this variable, and other variables that might be linked to it. E.g. Forrester (1994) starts identifying the system levels (=state variables) and later develops the flows, that cause those levels to change. This is focusing on quantities (state variables). But sometimes, one might be aware of a continuous process (erosion, deforestation) that want to represent; in this one could also start with a rate that affects other state variables. However, in DL, beginning at LS2, these dynamic elements need to be linked to entities, which are mainly used to capture the scale and structure of the system.

Following Ahl and Allen (1996), the world is populated by entities ('holons') at different spatial and temporal levels. They can interact within one hierarchical level or, with some restrictions, across hierarchical levels. But how to identify entities, and the way they interact? Following hierarchy theory (Ahl and Allen, 1996), one can use the definition of surfaces, which are often concrete parts of experience, to structure observation into relevant sub-units or entities. Surfaces as borders of entities allow via filters matter, energy, or information pass through themselves in characteristic rates. These boundaries might not be identifiable as clearly visible boundary in space; they also can be identified by their function in affecting rates of exchange. Therefore parts of a system can be easily separated from each when they have clearly identifiable surfaces or filters that obviously influence the exchange of information or signals.

Summarizing, developing models and also model based learning units using DynaLearn can be structured along the following steps (Ahl and Allen, 1996; Grant and Swannack, 2008):

- state the model objective, pose a question
- bound the system of interest, identify quantities, entities and structural units, and observe/define the relations between entities and the interactions between the units of measurements and important system states (corresponds to the topic review and an advanced LS 1 model)
 - think about the type of material that should be represented and where the material accumulates (=state variables); having identified a state variable first, leads quite naturally to think about other variables that are contributing or subtracting from this state variable describing material moving into, out of, and among state variables, which can be used to calculate the rate of change of the target variable.
 - look for any 'natural' flow of material passing through, or circulating within the system, that could serve as starting point of our model?
 - define the initial cause of change; this is the rate, that is usually set by the modeller as starting point of the simulation.
- categorize the components within the system-of-interest (e.g. in form of a table for a LS 2 model)
 - state variables – points of accumulation of material (number of individuals, biomass, kcal of energy accumulated in plants, kg of nutrients...)

- material transfers=rates – 1) from outside the system into a state variable, 2) between two state variables, 3) from a state variable out of the system – two variables connected by a material transfer must have the same units
- driving variables ('agents') – affect but are not affected by the rest of the system
- auxiliary variables – most commonly represent concepts or processes in the system-of-interest that we wish to indicate explicitly; they can be viewed as intermediate steps in determining the rate of material transfer or the value of another auxiliary variable.
- assign the identified state variables and rates to entities (needed from LS 2 upwards), observable units with surfaces and specific properties that can change; entities should be clearly identifiable units of experience assigned to specific temporal and spatial scales; entities and their configurations are the elements that can be used represent scale in DL models; they could be definitional or empirical, and one might consider re-organisation of the model structure after a certain time.
- identify the causal relationships among the components – system components can be connected by simple causal relations (LS 2) rates or proportionalities (LS 4-LS 6); rates, either positive, stable or negative, typically enter a state variable from a source; units of measure of material transfer must be the same as the state variables to which they are connected; proportionalities refer to the transfer of information about current directions of development of state variable via its derivative information (either increasing or decreasing) to another state variable or rate.
- develop a causal model based on the elements and relations identified above at a specific LS
 - LS 2 is specifically suited for initial and large scale causal models
 - LS 4 and LS 5 are designed to represent advanced system behaviour around central and basic processes and rates; typically the models are smaller as they are constructed as one expression; LS 5 hereby allows for using conditional statements to trigger behaviour
 - LS 6 models follow a compositional modelling approach, where parts of a system are defined in a generic way using model fragments, and then later linked by scenarios; hereby one can distinguish between static and process model fragments, and agents; the use of assumptions under which a specific behaviour can appear is only possible at LS 6; LS 6 can be considered as expert level for qualitative conceptual modelling
- consider building intermediate and sub-models, as models continuously grow and develop.
- evaluate the model
 - assess the reasonableness of the model structure and interpretability of functional relationships within the model
 - simulate the model and evaluate correspondence between model behaviour and the expected patterns of the quantities involved
 - for initial simulations, it makes sense to change the default preference settings of DL to restrict simulation behaviour: 'Apply fastest path heuristics' should activated and 'Epsilon ordering' should be set inactive; for further exploring model behaviour these settings can set back to default
 - Examine correspondence between model projections and data from the real world
- clearly document the goal, assumptions and limitations of the model and the community addressed
- develop lesson plans, assignments, working tasks and assessment schemata according to the level of performance of students;

6. Discussion and final conclusions

The work on the construction of advanced models supporting a dynamic understanding in environmental science yielded the understanding why the current approach to environmental education fails: it is the arbitrary fragmentation of knowledge into disciplines, where information is stored and communicated in an encyclopaedial manner, instead of having one dynamic knowledge source, where the adequate pieces are put together based on unifying principles and according to the needs of individual learners.

The advanced qualitative models presented here try to close the gap between disciplines using a conceptual approach, which allows for the seamless integration of different disciplines within dynamic causal models and simulations. Students can be easily guided from their everyday experience towards the understanding basic environmental patterns and processes, which requires cross-disciplinary integration. Insightful and recurring modelling patterns are thought to empower students best to explore environmental issues on their own. The advanced models presented here are mainly characterized by e.g. an intentional use of different Learning Spaces, consideration of hierarchy (entity definition and interaction), focusing on insightful re-applicable modelling patterns (initial cause propagates via different state variable through the system and creates an imbalance between two state variables, which creates a rate of change of the target variable).

During the development of the advanced models it became evident that it (still) represents a challenge to keep a clear and insightful model structure while keeping the simulation working. To keep the advantage of conceptual models over mathematical models, during model building the focus was therefore on the creation of insightful representations minimizing the load of QR specific elements that sometimes need to be introduced just to control the simulation behaviour and less to contribute to the causal understanding on the environmental issue. In some cases in LS 4, LS 5, and LS 6 the simulation preferences were changed according to this goal, to minimize ambiguity. Especially the activation of 'Apply fastest path heuristic' and the deactivation of 'Apply epsilon ordering' and/or 'Apply epsilon derivative continuity constraints' helped to minimize the possible states that would have been derived without using excessive control elements in models. Furthermore setting the initial values in scenarios and selecting adequate quantity spaces at LS 6 clearly requires advanced guidance. Most of the settings used within the advanced models were derived by trial and error.

In some cases QR specific elements, especially used at the higher Learning Spaces to control simulation behaviour, still might conflict with a more intuitive model building strategy, as already pointed out in Zitek et al. (2009), and create additional cognitive load. Generally it is therefore necessary to understand the modelling principles used in DL described in Zitek et al. (2010), especially the different information transfer modes of I's (from value to derivative) and P's (from derivative to derivative). Again, the introduction of clear and re-applicable modelling patterns can be seen as an important contribution for reducing the cognitive load coming from the modelling language, especially at the early stages of software use. Furthermore modelling could be significantly supported by examples of specific modelling patterns provided and explained by the software at the request of the student. This could be seen as extremely valuable extension of the basic hep feature that is mainly focusing on the technical implementation and not on modelling patterns so far.

This guidance with regard to modelling patterns typical and inherent in the DL language is of special relevance as during modelling usually an internalization of the whole modelling approach and language takes place (Clariana and Strobel, 2008). The teacher is hereby in full responsibility of selecting the modelling structure, defining the granularity of the model expression in accordance with the learning goals and providing the associated didactic material. However, when used intentionally and carefully, the specific QR language of DL is proven to provide effective means to gain a more causal and integrated view of environmental problems (Zitek et al., 2010; Zitek et al., 2011). From our experience, even after a short contact

with DL the new pattern of generic systemic information processing is applied to any issue in the world very quickly. Structured observation in general can be seen as the only interface between perception and learning as in absence of cognitive models, external dynamic processes possess no structure and meaning for the observer: therefore learning by modelling can be seen as *'preparing the eye'*: in order to make an observation one must have an idea of what can be seen, and an idea of how to integrate the observations (both, confirming and disconfirming) (Ahl and Allen, 1996).

Finally, the ultimate target of the proposed modelling strategy is, to lead the students from their perception of change towards an understanding of the involved elements and factors using universal principles and patterns.

Active, constructive, intentional, authentic and cooperative technology supported learning by modelling and simulation following a social constructivist strategy can be considered as most effective, motivating way of meaningful learning (Jonassen and Strobel, 2006).

However, it still remains a challenge to adequately re-design science curricula and develop new accompanying pedagogies (Webb, 2008), and the approach presented here can only be seen as first exploratory step in developing an integrative curriculum in environmental sciences guided by selected unifying principles.

Although the focus here was to develop an approach linked to river science, the thermodynamic and hierarchical principles can be considered as universal. A similar approach as presented here is chosen by the Miller and Spoolman (2009) in their text-book 'Living in the environment', why most of the models produced could be easily linked to this well-known existing international reference for environmental education.

Summarizing, advanced conceptual modelling with the DL software organized along an interdisciplinary curriculum and unified by basic principles is considered to be a powerful tool for the development of an advanced understanding of the environment.

7. References

- Ahl, V., Allen, T.F.H., 1996. *Hierarchy theory: a vision, vocabulary, and epistemology*. Columbia University Press, New York.
- Allen, T.F.H.H., T.W., 1992. *Toward a Unified Ecology*. Columbia University Press, New York.
- Annala, A., Salthe, S., 2009. Economies Evolve by Energy Dispersal. *Entropy* 11, 606-633.
- Assessment, M.E., 2005. *Ecosystems and human well-being - wetlands and water synthesis: a report of the Millennium Ecosystem Assessment*. World Resources Institute, Washington, DC, p. 68.
- Bradbury, I.K., Boyle, J., Morse, A., 2002. *Scientific Principles for Physical Geographers* Prentice-Hall (Pearson Education).
- Brady, L.L., Grisafe, D.A., McCauley, J.R., Ohlmacher, G.C., Quinodoz, H.A.M., Nelson, K.A., 1998. *The Kansas River Corridor--Its Geologic Setting, Land Use, Economic Geology, and Hydrology*. Released as Kansas Geological Survey Open-file Report 98-2, January 1998 (<http://www.kgs.ku.edu/Publications/KR/index.html>).
- Bredeweg, B., Salles, P., Bouwer, A., Liem, J., Nuttle, T., Cioaca, E., Nakova, E., Noble, R., Rios Caldas, A.-L., Uzunov, Y., Varadinova, E., Zitek, A., 2008. Towards a Structured Approach to Building Qualitative Reasoning Models and Simulations. *Ecological Informatics* 3, 1-12.
- Brookes, A., 1985a. Downstream Morphological Consequences of River Channelization in England and Wales. *Geogr J* 151, 57-62.
- Brookes, A., 1985b. River Channelization - Traditional Engineering Methods, Physical Consequences and Alternative Practices. *Prog Phys Geog* 9, 44-73.
- Brookes, A., 1987. River Channel Adjustments Downstream from Channelization Works in England and Wales. *Earth Surf Processes* 12, 337-351.
- Brookes, A., 1988. *Channelized rivers: perspectives for environmental management*. John Wiley & Sons, Chichester, New York, Brisbane, Toronto, Singapore.
- Brookes, A., Gregory, K.J., Dawson, F.H., 1983. An Assessment of River Channelization in England and Wales. *Science of the Total Environment* 27, 97-111.
- Clariana, R.B., Strobel, J., 2008. Modeling technologies, In: Spector, J.M., Merrill, M.D., Merrienboer, J.v., Driscoll, M.P. (Eds), *Handbook of research on educational communications and technology*. Lawrence Erlbaum, New York, pp. 329-344.
- Daly, H.E., Farley, J., 2003. *Ecological Economics*. Island Press, Washington DC.
- Diehl, E., Sterman, J.D., 1995. Effects of Feedback Complexity on Dynamic Decision Making. *Organizational Behavior and Human Decision Processes* 62, 198-215.
- Dollar, E.S.J., James, C.S., Rogers, K.H., Thoms, M.C., 2007. A framework for interdisciplinary understanding of rivers as ecosystems. *Geomorphology* 89, 147-162.
- Faissner, E., Flöry, P., Jaklin, J., Kiss, A., Koliander, B., Lang, O., Weiglhofer, H., Wiesinger, J., Ziegelbecker, R., Dorninger, C., 2010. *Naturwissenschaftliche Bildungsstandards - Berufsbildende Höhere Schulen: Das Kompetenzmodell (Version 9)*. Ministry of Education, Arts and Culture, Vienna, p. 30.
- Farabee, M.J., 2007. *Laws of thermodynamics* (Online Biology Book), <http://www2.estrellamountain.edu/faculty/farabee/biobk/biobookener1.html#Thermodynamics>.

- Forrester, J.W., 1994. System dynamics, systems thinking, and soft OR. *System Dynamics Review* 10, 245-256.
- Frissell, C.A., Liss, W.J., Warren, C.E., Hurley, M.D., 1986. A hierarchical framework for stream habitat classification: Viewing streams in a watershed context. *Environ Manage* 10, 199-214.
- Frumkin, H., (Ed.) 2010. *Environmental Health: From Global to Local*, 2nd Edition. Jossey-Bass, San Francisco.
- Grant, W.E., Swannack, T.M., 2008. *Ecological modelling: a common-sense approach to theory and practice*. Blackwell Publishing, Malden, Oxford, Victoria.
- Greitzer, E.M., Spakovszky, Z.S., Waitz, I.A., 2007. 16.Unified: Thermodynamics and Propulsion, Lecture Notes Version 6.2 (<http://web.mit.edu/16.unified/www/SPRING/propulsion/>). Quattrochi, D.
- Hammond, G.P., *Industrial energy analysis, thermodynamics and sustainability*. *Applied Energy* 84, 675-700.
- Houghton, J., 2005. Global warming. *Reports on progress in physics* 68, 1343–1403.
- Huggett, R., 2007. A history of the systems approach in geomorphology. *Géomorphologie : relief, processus, environnement* 2, 145-158.
- Imhof, J.G., Fitzgibbon, J., Annable, W.K., 1996. A hierarchical evaluation system for characterizing watershed ecosystems for fish habitat. *Canadian Journal of Fisheries and Aquatic Sciences* 53, 312 - 326.
- Irving, J.A., Klenke, 2004. Telos, chronos, and hermeneia: The causal role of metanarrative in leadership effectiveness through the production of meaning *International Journal of Qualitative Methods* 3, 28-48.
- Jonassen, D., Strobel, J., 2006. Modeling for Meaningful Learning, In: Hung, D., Khine, M.S. (Eds), *Engaged Learning with Emerging Technologies*. Springer Netherlands, Dordrecht, pp. 1-27.
- Jørgensen, S., E., Bastianoni, S., Müller, F., Patten, B.C., Fath, B.D., Marques, J.C., Nielsen, S.N., Tiezzi, E., Ulanowicz, R.E., 2007. *A New Ecology Systems Perspective*. Elsevier, Amsterdam & Oxford
- Jungwirth, M., Moog, O., Muhar, S., 1993. Effects of river bed restructuring on fish and benthos of a fifth order stream, Melk, Austria. *Regulated Rivers: Research & Management* 8, 195-204.
- Kiehl, J.T., Trenberth, K.E., 1997. Earth's Annual Global Mean Energy Budget. *Bulletin of the American Meteorological Association* 78, 197-208.
- Kondepudi, D.K., Prigogine, I., 1998. *Modern thermodynamics : from heat engines to dissipative structures*. John Wiley & Sons, Chichester ; New York.
- Lach, J., Wyzga, B., 2002. Channel incision and flow increase of the upper Wisloka River, southern Poland, subsequent to the reforestation of its catchment. *Earth Surf Processes* 27, 445-462.
- Leopold, L.B., 1994. *A view of the river*. Harvard Univ. Press, Cambridge, Mass. u.a.
- Leopold, L.B., Langbein, W.B., 1962. *The concept of entropy in landscape evolution*. U.S. Govt. Print. Off., Washington,.
- Li, B.-L., 2000. Why is the holistic approach becoming so important in landscape ecology? *Landscape and Urban Planning* 50, 27-41.
- Malmqvist, B., Rundle, S.R., 2002. Threats to the running water ecosystems of the world. *Environmental Conservation* 29, 134-153.
- Meadows, D.H., 2008. *Thinking in systems: a primer*. Chelsea green publishing company, Vermont.

- Meysman, F.J.R., Bruers, S., 2007. A thermodynamic perspective on food webs: Quantifying entropy production within detrital-based ecosystems. *Journal of Theoretical Biology* 249, 124-139.
- Miller, G.T., Spoolman, S.E., 2009. *Living in the environment: concepts, connections, solutions* (16th edition). Borrrks/Cole, Australia, Brazil, Japan, Korea, Mexico, Singapore, Spain, UK, US.
- Nanson, G.C., Huang, H.Q., 2008. Least action principle, equilibrium states, iterative adjustment and the stability of alluvial channels. *Earth Surf Processes* 33, 923-942.
- Nielsen, S.N., 2000. Thermodynamics of an ecosystem interpreted as a hierarchy of embedded systems. *Ecological Modelling* 135, 279-289.
- Noble, R., Salles, P., Zitek, A., Mioduser, D., Zuzovsky, R., Borisova, P., 2011. DynaLearn curriculum reflection and advancement. Deliverable D6.3. of the DynaLearn project, EC FP7 STREP project 231526, p. 54.
- Noble, R.A.A., Bredeweg, B., Linnebank, F., Salles, P., Cowx, I.G., 2009. A qualitative model of limiting factors for a salmon life cycle in the context of river rehabilitation. *Ecological Informatics* 4, 299-319.
- O'Neill, R.V., DeAngelis, D.L., Waide, J.B., Allen, T.F.H., 1986. *A Hierarchical Concept of Ecosystems*. Princeton University Press Princeton.
- Piégay, H., Grant, G., Nakamura, F., Trustrum, N., 2006. Braided River Management: from Assessment of River Behaviour to Improved Sustainable Development, In: Smith, G.H.S., Best, J.L., Bristow, C.S., Petts, G.E. (Eds), *Braided Rivers: Process, Deposits, Ecology and Management*. Blackwell Publishing Ltd., pp. 257-275.
- Prigogine, I., 1967. *Introduction to thermodynamics of irreversible processes* 3rd Ed. Wiley Interscience, USA.
- Rosen, M.A., Dincer, I., 2001. Exergy as the confluence of energy, environment and sustainable development. *Exergy, An International Journal* 1, 3-13.
- Rosgen, D.L., 1994. A classification of natural rivers. *CATENA* 22, 169-199.
- Russo, F., Williamson, J., 2007. Interpreting Causality in the Health Sciences. *International Studies in the Philosophy of Science* 21, 157-170.
- Shields, F.D., Lizotte, R.E., Knight, S.S., Cooper, C.M., Wilcox, D., 2010. The stream channel incision syndrome and water quality. *Ecological Engineering* 36, 78-90.
- Simon, A., 1989. A Model of Channel Response in Disturbed Alluvial Channels. *Earth Surf Processes* 14, 11-26.
- Simon, A., 1992. Energy, Time, and Channel Evolution in Catastrophically Disturbed Fluvial Systems. *Geomorphology* 5, 345-372.
- Sins, P.H.M., Savelsbergh, E.R., van Joolingen, W.R., 2005. The Difficult Process of Scientific Modelling: An analysis of novices' reasoning during computer-based modelling. *International Journal of Science Education* 27, 1695-1721.
- Smil, V., 2008. *Energy in Nature and Society*. MIT Press, Cambridge and London.
- Smith, L.A., Gentner, D. (2010). [The Use of Qualitative Principles to Promote Understanding of Systems](#). 24th International on Qualitative Reasoning, Portland, Oregon, USA.
- Sterman, J.D., 2000. *Business dynamics: systems thinking and modeling for a complex world*. Irwin McGraw-Hill, Boston e.a.
- Surian, N., Ziliani, L., Comiti, F., Lenzi, M.A., Mao, L., 2009. Channel adjustments and alteration of sediment fluxes in gravel-bed rivers of North-Eastern Italy: potentials and limitations for channel recovery. *River Res. Appl.* 25, 551-567.

- Svirezhev, Y.M., 2000. Thermodynamics and ecology. *Ecological Modelling* 132, 11-22.
- Thompson, R.D., 1998. *Atmospheric Processes and Systems*. Routledge Chapman & Hall, London.
- Thorp, J.H., Thoms, M.C., Delong, M.D., 2006. The riverine ecosystem synthesis: Biocomplexity in river networks across space and time. *River Res. Appl.* 22, 123-147.
- Tiezzi, E., 2011. Ecodynamics: Towards an evolutionary thermodynamics of ecosystems. *Ecological Modelling* in press, corrected proof.
- Trenberth, K.E., Smith, L., Qian, T.T., Dai, A., Fasullo, J., 2007. Estimates of the global water budget and its annual cycle using observational and model data. *J Hydrometeorol* 8, 758-769.
- Turchin, P., 2001. Does population ecology have general laws? *Oikos* 94, 17-26.
- Vannote, R.L., Minshall, G.W., Cummins, K.W., Sedell, J.R., Cushing, C.E., 1980. The River Continuum Concept. *Canadian Journal of Fisheries and Aquatic Sciences* 37, 130-137.
- Webb, M., 2008. Impact of IT on science education, In: Voogt, J., Knezek, G. (Eds), *International Handbook of Information Technology in Primary and Secondary Education*. Springer US, pp. 133-148.
- Wyzga, B., 1993. River Response to Channel Regulation - Case-Study of the Raba River, Carpathians, Poland. *Earth Surf Processes* 18, 541-556.
- Wyzga, B., Amirowicz, A., Radecki-Pawlik, A., Zawiejska, J., 2009. Hydromorphological Conditions, Potential Fish Habitats and the Fish Community in a Mountain River Subjected to Variable Human Impacts, the Czarny Dunajec, Polish Carpathians. *River Res. Appl.* 25, 517-536.
- Zawiejska, J., Wyzga, B., 2010. Twentieth-century channel change on the Dunajec River, southern Poland: Patterns, causes and controls. *Geomorphology* 117, 234-246.
- Zitek, A., Poppe, M., Stelzhammer, M., 2010. BOKU evaluation of DynaLearn Prototype. Deliverable D7.2.5. of the DynaLearn project, EC FP7 STREP project 231526. Institute of Hydrobiology and Aquatic Ecosystem Management, BOKU, Vienna.
- Zitek, A., Poppe, M., Stelzhammer, M., Muhar, S., Bredeweg, B., 2011. Evaluating the Effects of a New Qualitative Simulation Software (DynaLearn) on Learning Behavior, Factual and Causal Understanding. *Lecture Notes in Computer Science* 6738, 594-596.
- Zitek, A., Schmutz, S., Preis, S., Bredeweg, B., Salles, P., Muhar, S., 2009. Evaluating the potential of qualitative reasoning models to contribute to a sustainable catchment management. *Ecological Informatics*, 381-395.

Appendix A

8. Introductory master-story about the nature of river systems on Earth

8.1 Earth and the solar system

'We live on the surface of a planet that is in slow but constant change (Fig. 57). The processes accomplishing that change operate because the planet is very special – special in position in the solar system and special in size'.²⁷ 'The Earth is an interacting system of matter and energy, that as part of its functioning produces phenomena like volcanoes, glaciers, mountain ranges, oceans, and continents. The energy that keeps this system going is on one hand the internal heat (from radioactive decay) that drives plate tectonics, and on the other hand solar energy that maintains ocean and atmosphere circulation and helps to drive erosion'.²⁸



Figure 57: 'Earth is an ocean planet. Our home world's abundance of water -- and life -- makes it unique in our solar system. Other planets, plus a few moons, have ice, atmospheres, seasons and even weather, but only on Earth does the whole complicated mix come together in a way that encourages life -- and lots of it.'²⁹

The Solar System consists of the Sun and the astronomical objects gravitationally bound in orbit around it, all of which formed from the collapse of a giant molecular cloud approximately 4.6 billion years ago. Of the many objects that orbit the Sun, most of the mass is contained within eight relatively solitary planets whose orbits are almost circular and lie within a nearly flat disc called the ecliptic plane.

The four smaller inner planets, Mercury, Venus, Earth and Mars, also called the terrestrial planets, are primarily composed of rock and metal. Earth moves in an orbit nearer to the sun than Mars, but more distant than Mercury or Venus (Fig. 58).

The four outer planets, the gas giants, are substantially more massive than the terrestrials. The two largest, Jupiter and Saturn, are composed mainly of hydrogen and helium; the two outermost planets, Uranus and Neptune, are composed largely of ices, such as water, ammonia and methane, and are often referred to separately as "ice giants". The Solar System is also home to a number of regions populated by smaller objects. The asteroid belt, which lies between Mars and Jupiter, is similar to the terrestrial planets as it is composed mainly of rock and metal. Beyond Neptune's orbit lie the Kuiper belt and scattered disc; linked populations of trans-Neptunian objects composed mostly of ices such as water, ammonia and methane. Within these populations, five individual objects, Ceres, Pluto, Haumea, Makemake and Eris, are recognized to be large enough to have been rounded by their own gravity, and are thus termed dwarf planets. In addition to thousands of small bodies in those two regions, various other small body populations, such as comets, centaurs and interplanetary dust, freely travel between regions. Six of the planets and three of the dwarf planets are orbited by natural satellites, usually termed "moons" after Earth's Moon. Each of the outer planets is encircled by planetary rings of dust and other particles. The solar wind, a flow of plasma from the Sun, creates a bubble in the interstellar medium known as the heliosphere, which extends out to the edge of the scattered disc'.³⁰

²⁷ Leopold, L.B., 1994. A view of the river. Harvard Univ. Press, Cambridge, Mass. u.a.

²⁸ <http://www.indiana.edu/~geol105/1425chap4.htm>

²⁹ http://solarsystem.nasa.gov/multimedia/display.cfm?IM_ID=9643

³⁰ http://en.wikipedia.org/wiki/Solar_System

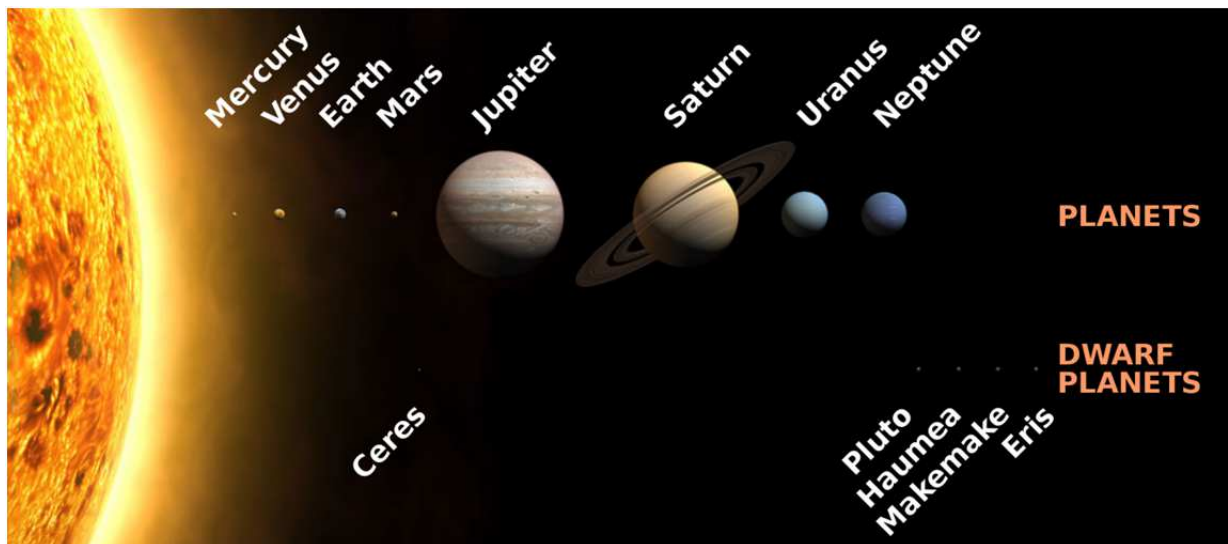

Figure 58: 'Planets and dwarf planets of the Solar System. Sizes are to scale, but relative distances from the Sun are not.'³¹

*'The Sun contains 99.85% of all the matter in the Solar System. The planets, which condensed out of the same disk of material that formed the Sun, contain only 0.135% of the mass of the solar system. Jupiter contains more than twice the matter of all the other planets combined. Satellites of the planets, comets, asteroids, meteoroids, and the interplanetary medium constitute the remaining 0.015%.'*³²

*'If Earth were appreciably closer to the sun, liquid water would not exist; it would occur only as vapour. And if Earth were much farther from the sun, water would be forever frozen. Moreover, Earth is just the right size, large enough to have a semimolten mantle from which volcanoes can erupt, bringing water vapour to the surface. Through this mechanism, it is believed, the oceans of Earth were slowly developed. The moon is too small to have such volcanic activity and cannot form or hold either oceans or atmosphere. Thus, by coincidence of favourable size and location in the solar system, Earth alone among the planets has oceans, an atmosphere, and thus a hydrologic cycle. The grand cycle of movement of water from ocean to atmosphere to continent and back to ocean is the essential mechanism that allows organisms – including humans – to emerge, to develop and to live on Earth.'*³³

8.1.1 The hydrologic cycle and its implications

*'Evaporation by the sun effects lifting of water into the atmosphere, and the counterforce to this process is gravity that forces rain to fall back on the earth and causes water move back to the oceans in streams (river systems), on the way eroding soils, cutting canyons, and transporting solids (silt, sand, clay) and dissolved salts to the oceans'*³⁴.

The Hydrologic Cycle involves the continuous circulation of water in the Earth-atmosphere system. Of the many processes involved in the hydrologic cycle, the most important are evaporation, transpiration, condensation, precipitation, and runoff (Fig. 59). *'The transfer of water vapor from the oceans to the atmosphere goes hand in hand with the transfer of tremendous amounts of thermal energy to the atmosphere and is very important for atmospheric circulation (see below). For this reason atmospheric circulation and winds can be considered part of the hydrologic cycle.'*³⁵

³¹ <http://commons.wikimedia.org/wiki/File:Planets2008.jpg>

³² From <http://www.solarviews.com/eng/solarsys.htm>

³³ http://www.srh.noaa.gov/jetstream/atmos/hydro_cycle.htm

³⁴ <http://www.indiana.edu/~geol105/1425chap4.htm>

³⁵ <http://www.indiana.edu/~geol105/1425chap4.htm>

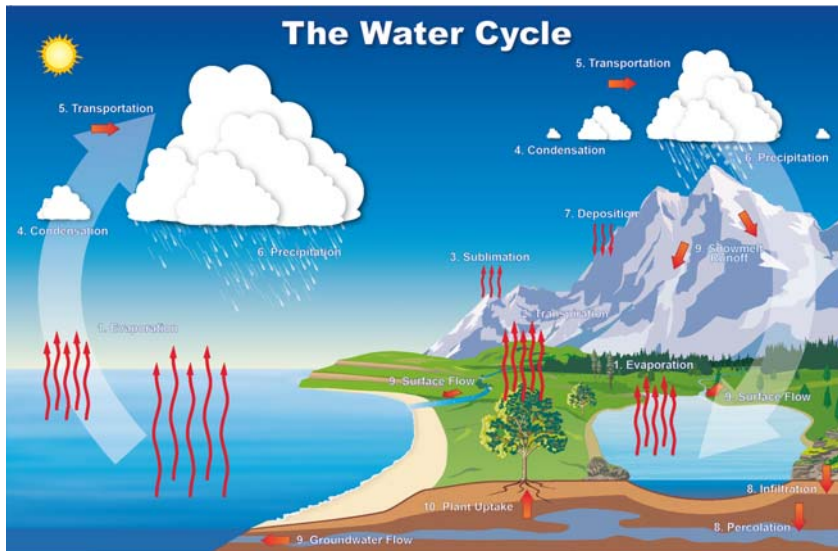

Figure 59: Elements of the hydrologic cycle.³⁶

1. *Evaporation is the change of state in a substance from a liquid to a gas. For evaporation to take place, energy is required. The energy can come from any source; the sun, the atmosphere, the earth, or objects on the earth such as humans.*
2. *Transpiration is the evaporation of water from plants through stomata. Stomata are small openings found on the underside of leaves that are connected to vascular plant tissues. In most plants, transpiration is a passive process largely controlled by the humidity of the atmosphere and the moisture content of the soil. About 90% of all water that enters the roots transpires into the atmosphere.*
3. *Sublimation is the process where ice and snow (a solid) changes into water vapor (a gas) without moving through the liquid phase.*
4. *Condensation is the process whereby water vapor in the atmosphere is returned to its original liquid state. In the atmosphere, condensation may appear as clouds, fog, mist, dew or frost, depending upon the physical conditions of the atmosphere. Condensation is not a matter of one particular temperature but of a difference between two temperatures; the air temperature and the dewpoint temperature.*
5. *Transportation is the movement of solid, liquid and gaseous water through the atmosphere. Without this movement, the water evaporated over the ocean would not precipitate over land.*
6. *Precipitation is water that falls to the earth. Most precipitation falls as rain but includes snow, sleet, drizzle, and hail. Around 515,000 km³ of water falls each year, mainly over the ocean.*
7. *Runoff is the variety of ways of which water moves over the earth's surface. This comes from melting snow or rain. This runoff flows into streams and rivers and eventually back into the sea.*
8. *Infiltration is the movement of water into the ground from the surface.*
9. *Groundwater flow is the flow of water underground in aquifers. The water may return to the surface in springs or eventually seep into the oceans.*
10. *Plant uptake is water taken from the groundwater flow and soil moisture³⁷.*

8.1.2 The sun as primary energy source

Most of the energy needed to drive the hydrological cycle stems from the sun. But how does the energy that is created by nuclear fission in the sun, travel to earth? And how is evaporation empowered by this energy transfer?

³⁶ http://www.srh.noaa.gov/jetstream/atmos/whatacycle_max.htm

³⁷ http://www.srh.noaa.gov/jetstream/atmos/whatacycle_max.htm

The Sun is mostly hydrogen and helium. In order to create energy, the Sun converts hydrogen to helium by nuclear fusion in a proton to proton reaction'.³⁸ 'Energy travels from the sun to the earth by means of electromagnetic waves. The shorter the wavelength, the higher the energy associated with it. Most of the sun's radiant energy is concentrated in the visible and near-visible portions of the spectrum. Shorter-than-visible wavelengths account for a small percentage of the total but are extremely important because they have much higher energy. These are known as ultraviolet wavelengths'.³⁹ Travelling at a speed of about 300,000 km/s in the form of waves with different wave length over the distance of about 150 million km from Sun to Earth, the Sun's energy reaches Earth in the form of light and heat waves after 8 minutes and 20 seconds. 'The Sun emits a tremendous amount of energy, in the form of electromagnetic radiation, into space. Averagely Earth receives around 342 W/m² over the entire surface of our spherical planet.'⁴⁰ 'Fortunately for us, all of the high energy X-rays and most UV is filtered out long before it reaches the ground.

Much of the infrared radiation is also absorbed by our atmosphere far above our heads. Most radio waves do make it to the ground, along with a narrow "window" of IR, UV, and visible light frequencies (Fig. 60).⁴¹ About half the energy of sunlight at the earth's surface is visible electromagnetic waves, about 3 percent is ultraviolet, and the rest is infrared'.⁴²

Figure 60: Various wavelengths of solar EM radiation penetrate Earth's atmosphere to various depths.

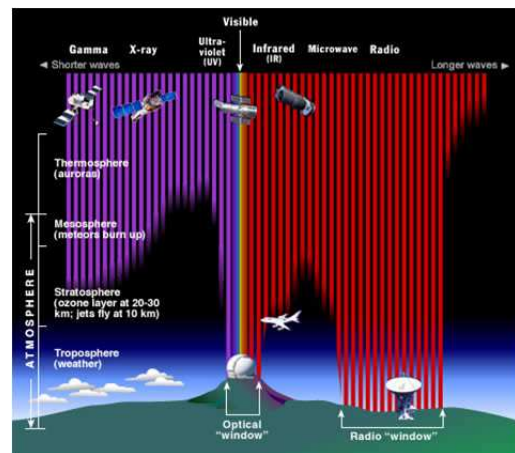

About 49% of the incoming radiation of 342 W/m² is absorbed by the earth surface, some is reflected and some is absorbed by the atmosphere (Kiehl and Trenberth, 1997) (Fig. 61). Earth itself emits energy in the long-wave spectrum, which being is reflected by greenhouse gases (water vapour, carbon dioxide, methane, nitrous oxide, and ozone); without this natural 'greenhouse-effect' the earth would be too cold to support life.⁴³

Figure 61: Earth's Annual Global Mean Energy Budget (Kiehl and Trenberth, 1997).

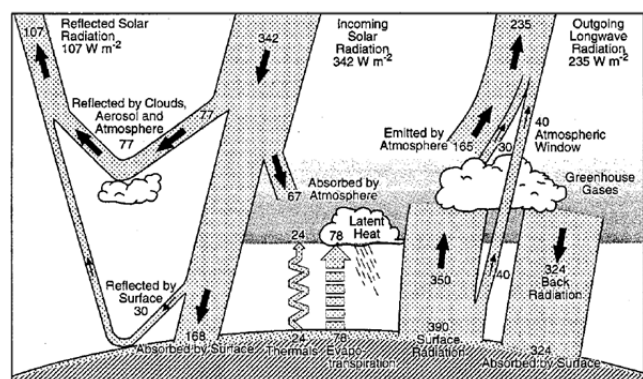

8.1.3 Interaction of light with matter

But how do sun rays interact with water or any other matter on earth? 'Light can interact with matter in three different ways: transmission, reflection (scattering is a kind of diffuse reflection), and absorption'.⁴⁴

Two points concerning this relationship should be noted. First, the proportions of energy reflected, absorbed, and transmitted will vary for different earth features, depending on their material type and condition. Second, the

³⁸ <http://www.universetoday.com/15021/how-long-does-it-take-sunlight-to-reach-the-earth/>

³⁹ http://www.ucar.edu/learn/1_1_1.htm

⁴⁰ http://www.windows2universe.org/earth/climate/sun_radiation_at_earth.html

⁴¹ http://www.windows2universe.org/earth/Atmosphere/earth_atmosph_radiation_budget.html

⁴² <http://web2.uwindsor.ca/edfac/student/spectrum.htm>

⁴³ <http://www.explainthatstuff.com/globalwarmingforkids.html>

⁴⁴ http://www.udel.edu/Geography/DeLiberty/Geog474/geog474_energy_interact.html

wavelength dependency means that, even within a given feature type, the proportion of reflected, absorbed, and transmitted energy will vary at different wavelengths'.⁴⁵

'All objects, living or inorganic are capable of absorbing light (Fig. 62). In all cases, absorption depends on the electromagnetic frequency of the light being transmitted (i.e. the color) and the nature of the atoms of the object. If they are complimentary, light will be absorbed'.⁴⁶

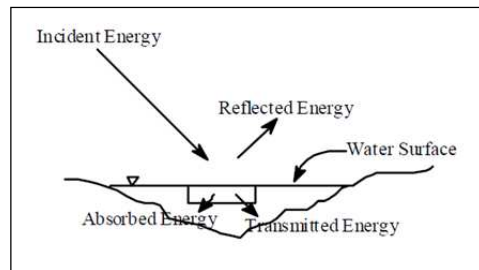

Figure 62: Basic interactions between Electromagnetic energy and a water body on Earth.

'All matter is composed of atoms and molecules. It is often useful to think of these atoms or molecules as primary particles which are attached to each other by springs. The particles and their attached springs have a tendency to vibrate or oscillate back and forth from their mean or average positions ('kinetic theory of matter'). They are in a state of constant vibrational motion. This motion is the essence of what we call heat. Thus, the main mechanism for storing mechanical energy of motion in these primary building blocks of matter is through heat, or thermal energy. Thermal energy manifests itself as energy of motion. Thus, heat is motion at the atomic and molecular levels. The primary mode of motion in atoms is vibration. The selective absorption of light by a particular material occurs because the selected frequency of the light wave matches the frequency at which the atoms of that material vibrate. Since different atoms and molecules have different natural frequencies of vibration, they will selectively absorb different frequencies (or portions of the spectrum) of visible light'.⁴⁷

The different parts of the electromagnetic spectrum have very different effects upon interaction with matter (Fig. 63)⁴⁸:

- 'Microwave interactions rotate molecules and produce heat as result of that molecular motion.
- Infrared absorption (mainly responsible for the heating of clear water by sun radiation) increases heat by increasing molecular vibrational activity.
- The primary mechanism for the absorption of visible light photons is the elevation of electrons to higher energy levels. There are many available states, so visible light is absorbed strongly. While exposure to visible light causes heating, it does not cause ionization.
- As you go to higher energies, the ionization energies for many molecules are reached and photoionization processes take place. Therefore higher frequencies in the ultraviolet are ionizing radiation and can produce harmful physiological effects ranging from sunburn to skin cancer. The ozone layer in the upper atmosphere absorbs most of the harmful ultraviolet (ionising) radiation from the sun before it reaches the surface'.⁴⁹

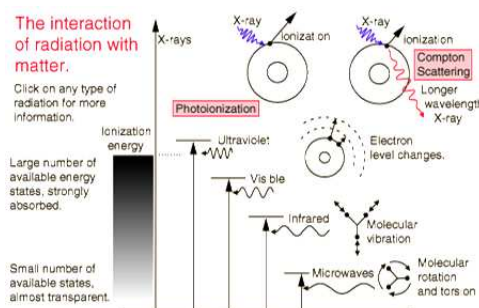

Figure 63: The interaction of radiation with matter.⁵⁰

⁴⁵ http://civil.iisc.ernet.in/~nagesh/rs_docs/Energyf.pdf

⁴⁶ <http://www.universetoday.com/87943/absorption-of-light/>

⁴⁷ <http://www.wavesignal.com/Light/index.html>

⁴⁸ <http://hyperphysics.phy-astr.gsu.edu/hbase/mod3.html>

⁴⁹ <http://hyperphysics.phy-astr.gsu.edu/hbase/mod3.html>

⁵⁰ <http://hyperphysics.phy-astr.gsu.edu/hbase/mod3.html>

The detailed mechanism of absorption with regard to heat absorption by water works as follows:

- *'Light consists of oscillating electric and magnetic fields.*
- *Because nuclei and electrons are charged particles, their motions in atoms and molecules generate oscillating electric fields.*
- *An atom or molecule can absorb energy from light if the frequency of the light oscillation and the frequency of the electron or molecular "transition motion" match. Unless these frequencies match, light absorption cannot occur. The "transition motion" frequency is related to the frequencies of motion in the higher and lower energy states. It is exactly the way in which you transfer energy to a child on a swing. You push at a frequency that matches that of the swing. Energy is transferred successfully, making the swing go to a higher energy state (higher amplitude), only if the push is made at the right time. If the frequency of pushing does not match the frequency of swinging, very little if any energy is transferred. In fact, the swing may actually lose energy if you try to push it while it is moving back toward you. This idea operates in the same way when light and matter interact. It is complicated only by the fact that, in contrast to the swing, molecules can undergo more than one type of motion.⁵¹*
- *As water is more or less transmissive for visual light, 'a property which is made good use of by photosynthesis and allowing production of both biomass and oxygen'⁵², it mainly absorbs energy from infrared radiation, also called heat radiation (Fig. 64). The energy absorption leads to an increase of the vibration of water molecules⁵³, which creates heat and can be measured as temperature.*

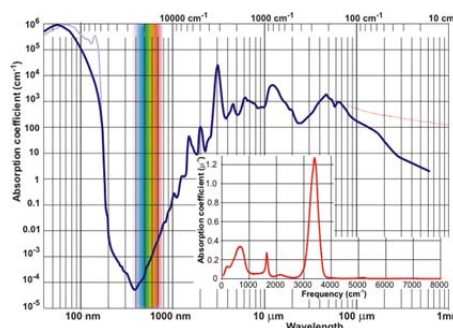

Figure 64: The visible and UV spectra of liquid water.⁵⁴

- *'The water molecules are perpetually vibrating. Some of those atoms vibrate sufficiently vigorously that their vibrational energy is roughly equal to the electronic energy (photons) absorbed from the sun--in essence, they are in resonance with the solar energy. Those atoms then make a quantum transition from 'electronically excited' to 'vibrationally excited,' meaning that the energy causes the whole atom to move. We feel that motion as "heat." The atoms which make the jump to vibrational excitation soon collide into neighboring molecules, dissipating their vibrational energy' (Fig. 65). But water, as air is a bad conductor, which favours thermal stratification.*

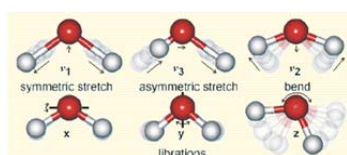

Figure 65: Possible vibrations of water molecules enhanced by the absorption of light energy.⁵⁵

'By the identification of which wavelengths of light are absorbed by a material, the material composition and physical properties can be elucidated. Physical evidence for the absorption of light is present in the appearance of color. If a material or matter absorbs light of certain wavelengths or colors of the spectrum, an observer will not see these colors in the reflected light. On the other hand if certain wavelengths of light are reflected from the material, an observer will see those colors and the substance will be associated with those colors'.⁵⁶

⁵¹ <http://www.wpi.edu/Academics/Depts/Chemistry/Courses/General/concept4.html#sec4-4>

⁵² <http://www.btinternet.com/~martin.chaplin/vibrat.html>

⁵³ <http://www.btinternet.com/~martin.chaplin/vibrat.html>

⁵⁴ <http://www.btinternet.com/~martin.chaplin/vibrat.html>

⁵⁵ <http://www.btinternet.com/~martin.chaplin/vibrat.html>

⁵⁶ <http://www.wavesignal.com/Light/index.html>

8.1.4 Energy conversion processes as major sources of change

'Stuff mixes, water flows downhill and wood burns into ashes. In the absence of other processes, sooner or later all matter would be uniformly mixed. Water would collect in the world's oceans, mountains would be eroded down to the seafloor, and wood would be burnt to ashes. These processes would transform the distribution of geochemical elements into a "dead" Earth state, with no gradients present to drive fluxes that result in global cycles of geochemical elements and no free energy would be available to "run" life.

These seemingly trivial observations highlight an underlying general direction into which any process in the Earth system evolves in time. The examples are processes that cannot be undone, or, technically speaking, they are irreversible. They happen spontaneously. This direction is understood and quantified in general terms using the fundamental theory of thermodynamics. Specifically, this is what the second law of thermodynamics tells us. The common form of this law formulates this direction in quantifiable terms, using entropy as a measure for the lack of gradients and free energy. By depleting gradients and sources of free energy, these processes are directed towards the state of thermodynamic equilibrium at which the entropy of the system is maximized. In this state, matter is well mixed and no free energy is available to perform physical work, or run chemical or metabolic reactions.

This fundamental view also applies to the geochemical processes and global cycles of Earth as well as life itself. The Earth's state far away from a "dead" state with highly active geochemical cycling and the abundance of life appear to contradict this general direction and thus seem to violate the second law of thermodynamics. What is it about the planet Earth which allows it to be maintained so far away from the final, "dead" state of thermodynamic equilibrium? Which processes perform the physical and chemical work that separates stuff, moves water uphill, forms mountains, and produces wood out of ashes? In general terms, what creates the gradients that are required for the maintenance of global geochemical cycling?

Life has found various ways -- as reflected in its inherent diversity -- to generate and utilize sources of free energy and this has profoundly altered the environmental conditions on Earth. Many biotic effects directly affect the rates of geochemical processes, with consequences for the global cycles of carbon, water, and oxygen. How do these biotic effects alter the resulting thermodynamic state of the Earth system? To what extent is the unique thermodynamic state of Earth the result of the abundant and highly active biosphere? Which role does diversity play in the functioning of the biosphere and its ability to evolve and adapt?'.⁵⁷

Most of the energy on earth comes from the Sun's energy, the internal heat on earth and gravitational forces although qualitatively indispensable represent the other quantitatively less important sources of energy on earth (Smil, 2008).

'Both, the tectonic and the hydrologic system, are characterized by ongoing transfers of energy and matter.

The forms of energy that are most important in geologic processes are:

- *Kinetic Energy (meteorite impact, movement of wind and water, ocean currents)*
- *Gravitational Potential Energy (falling rain gains kinetic energy from its gravitational potential, water flowing down from mountains)*
- *Thermal Energy (input from the sun, radioactive decay, molten rocks). Transmitted by conduction, convection, radiation*
- *Chemical Energy (holds together atoms in molecules, the energy of the chemical bond)*
- *Nuclear Energy (released during radioactive decay)*

⁵⁷ <http://terpconnect.umd.edu/~akleidon/>

All those various forms of energy occur and are transformed into each other as geologic processes proceed (kinetic energy to heat during meteorite impact; thermal energy to chemical energy and vice versa during melting and recrystallization; thermal energy into gravitational potential energy [sun evaporates water and forms clouds] - gravitational potential energy into kinetic energy [rain drops fall]). The total amount of energy that moves through the system is huge. It is on the order of 174,000 terawatts (1 terawatt = 10¹² watts [energy per time]; 1 horsepower = 746 watts). Almost all of this energy comes to us via solar radiation. The Earth system receives 5000 times more energy from the sun than from the interior of the planet. Thus, although its manifestations are impressive (mountain ranges, earthquakes, volcanoes), the internal energy that keeps up mantle convection and drives the tectonic plates is only a small fraction of the energy that moves through the system. To put it into perspective, the total energy production by humans is about 9.6 terawatts at any given time. Thus, there is plenty of energy in the system. Even if humans were to extract all their energy needs from the solar input, there would still be plenty of energy left to keep the planet going. Solar energy input dominates the surface processes (wind, weather, climate, ocean circulation, etc.) of the Earth, and because the Earth is a sphere, its input is not uniform across the planet. The concentration of solar energy per unit area depends on the angle at which the solar radiation arrives'.

Just like in our hot water pot that was heated from below, the uneven global heat distribution gives rise to convection currents that attempt to equalize the heat distribution.

In its most simple form we can imagine that heated air at the equator rises up, and spreads north and south towards the poles. It gradually cools, sinks down in the polar regions, and then flows across the Earth surface to the equator. There it heats up again and the convective cycle is repeated. This is what would happen if the Earth did not rotate. Rotation adds another twist to the story, because the Coriolis Effect makes the northward flowing currents veer off course (to the right, in the direction of rotation). The Coriolis Effect breaks the air exchange between equator and poles into three circulation belts.

An important aspect of global air circulation is the movement of water through the atmosphere. Water has a much higher heat capacity than the atmospheric gases. Its heat capacity is approximately four times that of air (heat capacity of water = 1 cal/gm/deg). In addition, because water changes from the liquid to the gas state (evaporation of water) and back (condensation into clouds) as it gets cycled through the atmosphere, we also have to consider the latent heat of vaporization (540 cal/gm). This is the amount of heat necessary to get the water molecules into the gas state. For example, if we evaporate a liter (1 kg) of water, 540,000 calories of latent heat are stored in the vapor. Once the water condenses, this latent heat is released, and heats up the surrounding air. If we assume for example that this water vapor is contained in 1000 kg of air (roughly 1000 cubic meters, or a cube of 10 meters size), it would heat up this air mass by about two degrees as it condenses. Air at 30 degrees C (86 degrees F) can hold up to 30 grams of water vapor per cubic meter (or kilogram) of air. If this water vapor condenses it releases 16,200 calories of latent heat. This in turn can cause the air to heat up as much as 64 degrees C. It is just like heating the air up in a hot air balloon. The air will expand and rise (think of rising and billowing clouds before a thunderstorm). For these reasons, condensing or vaporizing water has a profound effect on atmospheric circulation, and moist air masses are prone to very powerful climatic disturbances (e.g. thunderstorms, tornadoes, hurricanes).

Water vapor is constantly cycling through the atmosphere, evaporating from the surface, condensing to form clouds blown by the winds, and subsequently returning to the Earth as precipitation. Heat from the Sun is used to evaporate water, and this heat is put into the air when the water condenses into clouds and precipitates. This evaporation-condensation cycle is an important mechanism for transferring heat energy from the Earth's surface to its atmosphere and in moving heat around the Earth.

Water also has a substantially higher heat capacity than rocks (by a factor of five), and therefore the oceans can store much more heat than the land surfaces of the planet. Because the oceans also cover about 70% of the Earth surface and are on average 3.8 km deep, they are the major heatsink of the planet and serve as temperature buffers for the ocean/atmosphere system. The bulk of the thermal energy at the Earth surface is stored in the oceans. The large thermal inertia of the oceans is a key factor in stabilizing Earth's climate. 'Because the oceans are

of course also heated more intensely in the equatorial regions, there is abundant warm water near the equator, and cold water in the polar regions. The atmospheric circulation that is set up between the equator and the poles also influences the redistribution of these water masses. Wind blowing over the ocean surface exerts drag (friction) and starts to move the surface waters. In addition the currents are influenced by the Coriolis Force and the tides. The currents are also influenced by the position of landmasses.

At its simplest, climate is a reflection of local, regional, and global distributions of temperature and precipitation -- in turn determined by the latitudinal distribution of the energy received from the Sun, the absorption and transport of that energy within the Earth System, and its re-emission to space.

Although circulation of air masses and ocean waters (as outlined above) plays a significant role in determining global heat exchange and average world temperatures, there are several other, more fundamental, controls on climate. The basic items that determine Earth climate are:

1. Astronomical Parameters
2. Distribution of Continents and Oceans
3. The Greenhouse Effect

Earth's rapid rotation about its axis (compared to the time for one orbit around the Sun) determines day and night, spreads the incoming solar radiation more or less uniformly around circles of latitude, and strongly affects circulation patterns in the oceans and atmosphere.

The eccentricity of Earth's orbit modulates the intensity of the incoming solar radiation through the course of the year (Fig. 10). The tilt of Earth's axis with respect to the ecliptic plane results in the seasons. Note, that it is summer in the northern hemisphere when the Earth is closest to the sun (perihelion, January 3rd, 147 million km), and winter when it is farthest away (aphelion, July 4th, 152 million km). Thus, the tilting of the northern hemisphere towards the sun in summer (longer days, more solar energy input) and the tilting away from the sun in the winter (shorter days, less solar energy input) are more important than the actual distance to the sun'.⁵⁸

The angle in which the solar radiation hits our planet, significantly affects the amount of heat transferred. This results in a higher amount of radiation received at the equator compared to higher latitudes (Fig. 66). This phenomenon also creates the seasons on our planet due the angled position of the earth axis (23.45° from the ecliptic⁵⁹).

Absorption of energy from the sun is the major source of energy for any dynamic processes on earth.

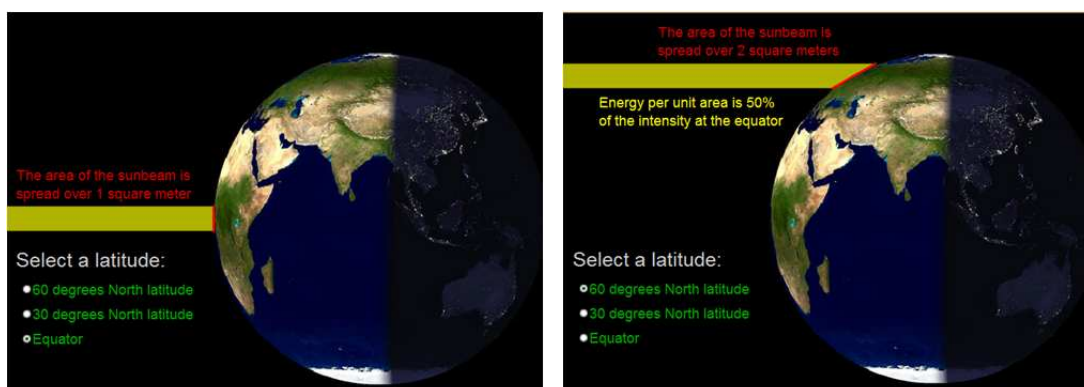

Figure 66: Illustration of how solar energy intensity per unit area varies with latitude.⁶⁰

⁵⁸ <http://www.indiana.edu/~geol105/1425chap4.htm>

⁵⁹ <http://www.enchantedlearning.com/subjects/astronomy/planets/earth/Seasons.shtml>

⁶⁰ http://www.windows2universe.org/earth/climate/sun_radiation_at_earth.html

8.1.5 The nature of energy

'Energy can be found in many things and takes many forms. There is potential energy in objects at rest that will make them move if resistance is removed. There is kinetic energy in objects that are moving. The molecules making up all matter contains a huge amount of energy, as Einstein's $E = mc^2$ pointed out to us. Energy can also travel in the form of electromagnetic waves, such as heat, light, radio, and gamma rays. Your body is using metabolic energy from your last meal as you read this. Energy is constantly flowing and changing form. If you take your metabolic energy and rub your hands together, you have made metabolic energy into mechanical energy. Your hands will heat up. That is some of the mechanical energy turning into heat energy.

So energy can change form, but where did that energy ultimately come from? Let's trace back a chain of events (Fig. 67).

A bicycle is rolling down the hill, transferring potential energy into kinetic (movement) energy. The bicycle got its potential energy (energy due to position related to gravity) by the rider using metabolic energy to move the pedals. The pedals used mechanical energy to move the chain, which moved the wheels. The rider's metabolic energy came from chemical energy that was stored in the molecules of the food she ate.

That chemical energy entered the animal whose meat she ate by the animal digesting a plant and breaking the bonds in its molecules. The plant made the molecules by using light energy from the Sun. The Sun's light energy came from electrons in its atoms lowering energy states, and releasing energy. The energy in the atoms came from the nuclear reactions in the heart of the Sun. What started the nuclear reactions? Physicists think the Big Bang did.

Summarizing, the energy we encounter and use everyday has always been with us since the beginning of the universe and always will be with us. It just changes form all around us. That is called the law of conservation of energy'.⁶¹

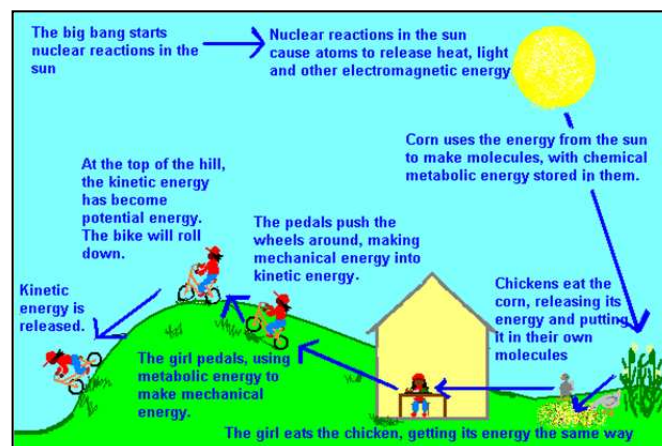

Figure 67: Energy transfer at earth.

8.1.6 The principle of thermal energy (=heat) transfer

For examples, differences in absorption of energy between soil and water create lots of Earth's climate and weather phenomena (wind, sea-land circulation patterns, global circulation patterns etc.). Because of its lower specific heat (the amount of heat required to warm a given volume 1 degree Celsius), soil in principle heats faster, but as the sun energy cannot penetrate very deep, only the upper layer is heated and therefore cools faster. In water, which is heating up slower because it has four times the specific heat as most land surfaces, the sun light can penetrate in more depth, so a greater body of water is heated, and much more energy can be taken taken up. Furthermore the possibility of vertical mixing by convection is given. That's

⁶¹ <http://www.qrg.northwestern.edu/projects/vss/docs/thermal/3-where-does-energy-come-from-and-go.html>

why water masses cool slower than land.⁶² 'Air heats up relatively quickly for two reasons: first, because the specific heat capacity of air is about a quarter of water's; second, because air is a gas, it has relatively little mass'.⁶³

'Heat in principle can be transferred from one place to another by three methods: conduction in solids, convection of fluids (liquids or gases), and radiation through anything that will allow radiation to pass (without the need for direct contact) (Fig. 68). The method used to transfer heat is usually the one that is the most efficient. If there is a temperature difference in a system, heat will always move from higher to lower temperatures'.⁶⁴

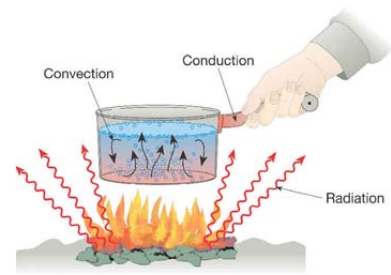

Figure 68: Principles of heat transfer.⁶⁵

'**Conduction** occurs when two objects at different temperatures are in contact with each other. Heat flows from the warmer to the cooler object until they are both at the same temperature. Conduction is the movement of heat through a substance by the collision of molecules. At the place where the two objects touch, the faster-moving molecules of the warmer object collide with the slower-moving molecules of the cooler object. As they collide, the faster molecules give up some of their energy to the slower molecules. The slower molecules gain more thermal energy and collide with other molecules in the cooler object. This process continues until heat energy from the warmer object spreads throughout the cooler object. Some substances conduct heat more easily than others. Solids are better conductors than liquids and liquids are better conductors than gases. Metals are very good conductors of heat, while air is a very poor conductor of heat.

In liquids and gases, **convection** is usually the most efficient way to transfer heat. Convection occurs when warmer areas of a liquid or gas rise to cooler areas in the liquid or gas. As this happens, cooler liquid or gas takes the place of the warmer areas which have risen higher. This cycle results in a continuous circulation pattern and heat is transferred to cooler areas. You see convection when you boil water in a pan. The bubbles of water that rise are the hotter parts of the water rising to the cooler area of water at the top of the pan. You have probably heard the expression "Hot air rises and cool air falls to take its place" - this is a description of convection in our atmosphere. Heat energy is transferred by the circulation of the air.

Both conduction and convection require matter to transfer heat. **Radiation** is a method of heat transfer that does not rely upon any contact between the heat source and the heated object. For example, we feel heat from the sun even though we are not touching it. Heat can be transmitted through empty space by thermal radiation. Thermal radiation (often called infrared radiation) is a type of electromagnetic radiation (or light). Radiation is a form of energy transport consisting of electromagnetic waves traveling at the speed of light. No mass is exchanged and no medium is required. Objects emit radiation when high-energy electrons in a higher atomic level fall down to lower energy levels. The energy lost is emitted as light or electromagnetic radiation. Energy that is absorbed by an atom causes its electrons to "jump" up to higher energy levels. All objects absorb and emit radiation. (Here is a Java applet showing how an atom absorbs and emits radiation) When the absorption of energy balances the emission of energy, the temperature of an object stays constant. If the absorption of energy is greater than the emission of energy, the temperature of an object rises. If the absorption of energy is less than the emission of energy, the temperature of an object falls'.⁶⁶

'Heat from the Sun is used to evaporate water (the specific heat), and this heat is put (released) into the air when the water condenses into clouds and precipitates (Fig. 69). This evaporation-condensation cycle is an important mechanism for transferring heat energy from the Earth's surface to its atmosphere and in moving heat around the

⁶² http://icecap.us/images/uploads/ENSO,PDO_and_Climate.pdf

⁶³ <http://www.explainthatstuff.com/heat.html>

⁶⁴ http://coolcosmos.ipac.caltech.edu/cosmic_classroom/light_lessons/thermal/transfer.html

⁶⁵ http://www.geography.hunter.cuny.edu/~tbw/wc.notes/2.heating.earth.surface/mechanisms_heat_transfer.htm

⁶⁶ http://coolcosmos.ipac.caltech.edu/cosmic_classroom/light_lessons/thermal/transfer.html

Earth'.⁶⁷ 'When a substance changes phase, that is it goes from either a solid to a liquid or liquid to gas, the energy, it requires energy to do so. The potential energy stored in the interatomic forces between molecules needs to be overcome by the kinetic energy the motion of the particles before the substance can change phase. Latent heat is the energy absorbed or released when a substance changes its physical state. Latent heat is absorbed upon evaporation, and released upon condensation to liquid (as in clouds). Latent heat is also absorbed when water melts, and released when it freezes'.⁶⁸ 'The latent heat of water is 540 cal/g'.⁶⁹

Latent heat release during condensation of water vapour into clouds can be seen as one major element of hurricane formation.⁷⁰

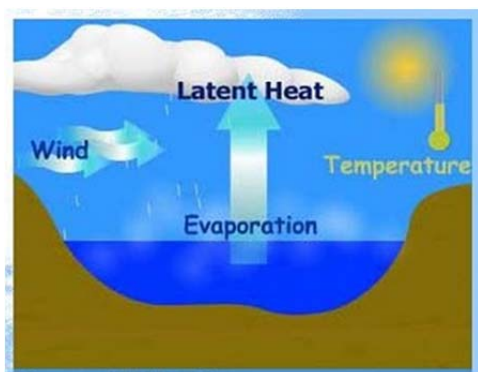

Figure 69: The principles of latent heat.⁷¹

8.2 Principles of Life on Earth

Life on earth depends on three interconnected factors: the one way flow energy from the sun (the first and second law of thermodynamics govern this energy flow: according to the 1st law no energy can be created nor destroyed when energy is converted from one form to another and according to the 2nd law we end up with lower quality or less suitable quality of energy, whenever energy is changed from one form to another), the cycling of matter or nutrients (the law of conservation of matter governs this nutrient process), gravity which allows the planet to hold its atmosphere and helps to enable movement and cycling of chemicals through air, water, soil and organisms (Miller and Spoolman, 2009).

8.2.1 Life, ecosystems and food webs

,The development of life forms that we know from earth has been possible because earth has the elements that are needed to build biochemical compounds that explain the life processes. It includes water that is an ideal solvent for biochemical reactions. In addition, the earth has the right temperature range that means that the biochemical reactions proceed with a certain rate and that the decomposition of particularly proteins is moderate. The right balance between formation and destruction of high molecular proteins that are the enzymatic compounds controlling the life processes is thereby obtained. Carbon-based life has a viability domain between approximately 250 and 350 K (~-23°C to 77°C).

The history of life on Earth can be viewed as the history of chemotrophic life, followed by the photosynthesis and hostroy of evolution, as the history of a singular planet that learned to capture solar energy, feed on the negative entropy of the universe for the creation of complex self-perpetuating structures (living organisms). The sun is an

⁶⁷ <http://www.indiana.edu/~geol105/1425chap4.htm>

⁶⁸ <http://physicstutors.blogspot.com/2010/06/latent-heat.html>

⁶⁹ <http://www.indiana.edu/~geol105/1425chap4.htm>

⁷⁰ [http://ww2010.atmos.uiuc.edu/\(Gh\)/wwhlpr/hurricane_latent_heat.xml](http://ww2010.atmos.uiuc.edu/(Gh)/wwhlpr/hurricane_latent_heat.xml)

⁷¹ <http://physicstutors.blogspot.com/2010/06/latent-heat.html>

enormous engine that produces energy and offers Earth the possibility of receiving large quantities of neative entropy (organization, life).

The life processes take place in cells, because they have a sufficiently high specific surface to allow an exchange rate with the environment that is suitable. Cells are,therefoe, the biological units that make up organs and organisms. Nature must, therefore, use a hierarchical construction: atoms, molecules, cells, organs, organisms, populations, communities, ecosystem, and the ecosphere. The addition of units in one hierarchical level to form the next level gives the next level new and emergent properties. Prigogine uses the term dissiptative structure to denote self organizing systems, thereby indicating that such systems dissipate energy (produce entropy) for the maintenance of their organization (order)' (Jørgensen et al., 2007).

'Ecosystems and the biosphere are sustained through a combination of one-way energy flow from the sun and nutrient cycling of key materials within them' (Miller and Spoolman, 2009).

The fundamental source of energy in almost all ecosystems is radiant energy from the sun; energy and organic matter are passed along an ecosystem's food chain.

Organisms are classified based upon the number of energy transfers through a food web (Fig. 70).

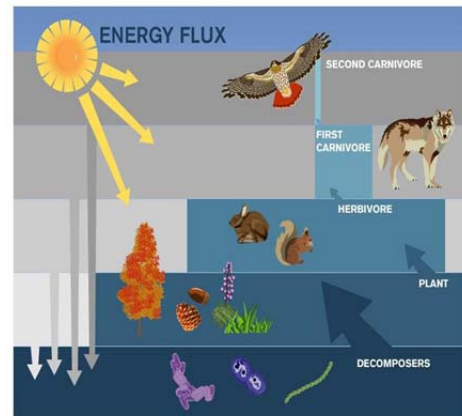

Figure 70: 'Illustration of the food web on Earth'.

Photoautotrophic production of organic matter represents the first energy transfer in ecosystems and is classified as primary production. Consumption of a plant by a herbivore is the second energy transfer, and thus herbivores occupy the second trophic level, also known as secondary production. Consumer organisms that are one, two, or three transfers from autotrophs are classified as primary, secondary, and tertiary consumers. Moving through a food web, energy is lost during each transfer as heat, as described by the second law of thermodynamics. Consequently, the total number of energy transfers rarely exceeds four or five; with energy loss during each transfer, little energy is available to support organisms at the highest levels of a food web'.⁷²

'A change in the size of one population in a food chain will affect other populations. This interdependence of the populations within a food chain helps to maintain the balance of plant and animal populations within a community'.⁷³

Decomposers are the key component of nutrient cycling, because its mainly them who are able to break down organic matter into its basic components that can be re-used by producers (Miller and Spoolman, 2009).

The major nutrient cycles on earth are: hydrologic, carbon, nitrogen, phosphorous and sulfur cycles (Miller and Spoolman, 2009). These cycles are the major components of Earth's natural capital, and humans are significantly altering them (Miller and Spoolman, 2009). Based on the basic cycling of energy and the interaction between organisms, ecology has three major subdisciplines (Tab. 10):

⁷² <http://ecoplexity.org/node/132>

⁷³ <http://www.vtaide.com/png/foodchains.htm>

Table 10: Major sub-disciplines of ecology (Frumkin, 2010).

Subdiscipline	Focus
Ecosystem ecology	Whole systems view; ecosystem as unit of study; emphasis on energy and material cycles.
Community ecology	Interactions of species; emphasis on species' composition and diversity.
Population ecology	Population-level processes; emphasis on population dynamics and regulation, and on interspecies interactions.

8.2.2 The principle of photosynthesis

'When a photon interacts with a particle of matter on our planet, it raises an electron or a pair of electrons to a higher energy level. This excited state usually has a brief life and the electron falls back to its basic level in 10^{-7} - 10^{-8} s, giving up its energy in one way or another. Life has learned to capture the electron in the excited state, to uncouple it from its partner and to let it decay to its fundamental level through the biological machinery, using the extra energy for vital processes' (Jørgensen et al., 2007).

Photosynthesis conducted by primary producers on earth in this way captures about 1 % of the solar energy that falls on fertile land and water in the form of high energy organic molecules (Jørgensen et al., 2007). According to Jørgensen et al. (2007), *'the global ecological system or biosphere can be defined as the part of Earth's surface that is ordered by the flow of energy by means of the process of photosynthesis'* (the principle of photosynthesis based on light absorption is shown in Fig. 71).

Figure 71: Principle of photosynthesis based on light absorption.⁷⁴

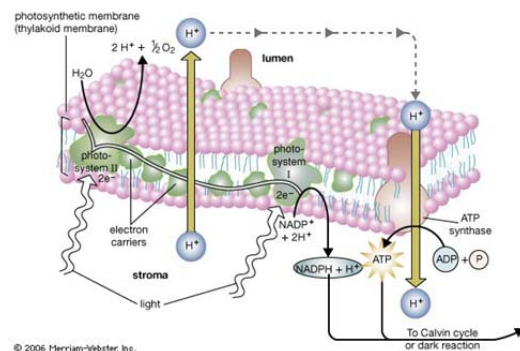

8.3 Rivers as result of energy conversion processes

'Water plays a part in all physical and biological processes. It is essential to the actions that have developed the Earth's surface as we now observe it. Mountains are forced up by the collision of the great plates that make up the Earth's crust. But mountains on the continental surfaces are gradually worn away by ubiquitous weathering of their rocks, and the transport of weathered products downhill by the action of water, wind and gravity (water is also moving downstream due to the force of gravity). The weathering processes that change hard rocks to erodible material incorporate water at every stage. Furthermore water is the principal agent of movement of the weathered material that makes up the soil and supports vegetation, of the sedimentary rocks formed by the accumulation of the weathered products, and the channels along which they are carried.'

All the water presently on and in the surface of the earth was brought by volcanic action. What we see and use is derived from precipitation. The grand pattern of circulation of water called the hydrologic cycle describes in general terms what happens through time as water evaporates from ocean, plants, and soil, moves in the atmospheric circulation, and re-precipitates locally or far away from its point of evaporation.

When precipitation falls on a continent, it separates into that which infiltrates the ground, that which immediately evaporates, and that which runs off the ground surface (or is stored as snow).

⁷⁴ http://smabiology.blogspot.com/2008_12_01_archive.html

The excess of precipitation over evapo-transpiration loss to the atmosphere is a surprisingly small percentage of the average precipitation⁷⁵ (see also Fig. 72 and Fig. 73).

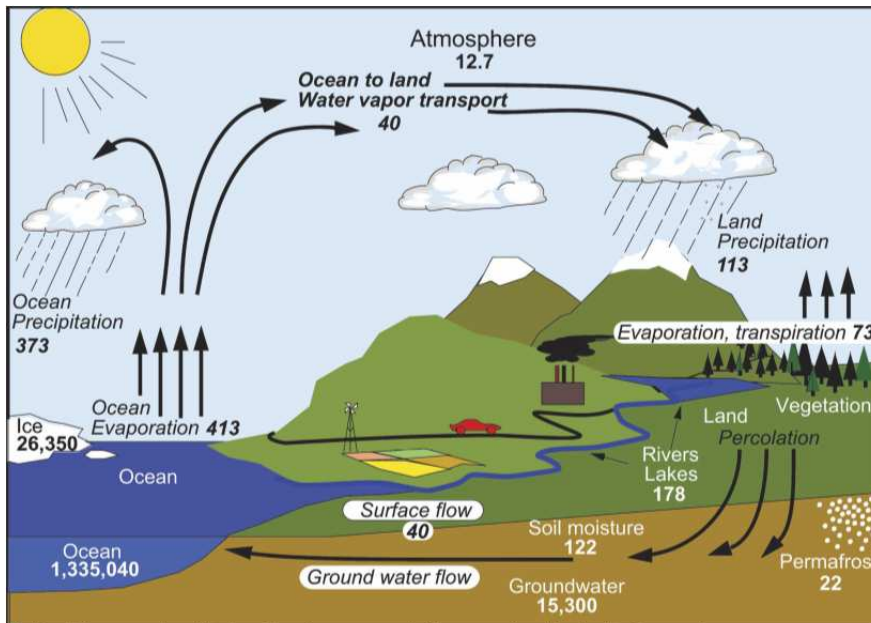

Units: Thousand cubic km for storage, and thousand cubic km/yr for exchanges

Figure 72: The hydrological cycle. Estimates of the main water reservoirs, given in plain font in 10^3 km^3 , and the flow of moisture through the system, given in slant font ($10^3 \text{ km}^3 \text{ yr}^{-1}$), equivalent to $Eg (10^{18} \text{ g}) \text{ yr}^{-1}$ (Trenberth et al., 2007).

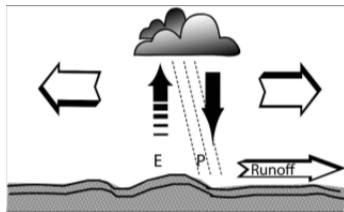

Figure 73: Schematic of the local atmospheric water balance. The large arrows indicate atmospheric moisture divergence, which is mostly compensated for by evapotranspiration E and precipitation P , as changes in atmospheric moisture storage are small. At the surface $E - P$ is balanced by surface and subsurface runoff, and changes in soil moisture and groundwater (Trenberth et al., 2007).

The runoff carves or maintains channels of rill, stream and river. This water on the surface may infiltrate, evaporate, or somewhere else be augmented by emerging groundwater.

Rivers are both the means and routes by which products of continental weathering are carried to the oceans of the world. More water falls as precipitation than is lost by evaporation and transpiration from land surface to the atmosphere. Thus there is an excess of water, which must flow to the oceans. Rivers, then, are the routes by which this extra water flows to the ultimate base level. The excess of precipitation over evaporation and transpiration provides the flow of rivers and springs, recharges groundwater storage, and is supply from which humans draw to meet their needs.

A good deal of the water that appears as river flow is not transmitted into river channels immediately after falling as precipitation. A large percentage is infiltrated into the ground and flows underground to the river channels. This process provides, then, a form of storage and thus regulation that sustains flow of streams during nonstorm or dry periods of bright, sunny weather. The discharge represents water that has been fallen during previous storm periods and has been stored in the rocks and in the soils of the drainage basin. Each river is fed mainly from two sources, overland flow to a channel and groundwater emerging at the channel boundary. Source of overland flow could also be water stored as snow and ice and provided during periods of melting.

The shape of a cross section of any river channel is a function of the flow, the quantity and character of sediment motion through the section, and the character or composition of materials (including the vegetation) that make up the bed and banks of the channel. A natural channel migrates laterally by erosion of one bank, maintaining on

⁷⁵ Leopold, L.B., 1994. A view of the river. Harvard Univ. Press, Cambridge, Mass. u.a.

average a constant channel cross section by deposition on the opposite bank. In other words, there is an equilibrium between erosion and deposition. The effect of changes in bank material on channel form depends on the relative resistance of bed and bank material. As the threshold of erosion of the bank material increases, whether by the addition of coarse or cohesive sediments or by the presence of vegetation or bedrock, with no change in the bed material or discharge, the channel will be narrower. Thus channels with cohesive silty banks and beds will be narrower than those built up from easier erodible material (sand, gravel).

Only a few definitions are really necessary to an understanding of morphologic processes in rivers. This is one: A floodplain is a level area near a river channel, constructed by the river in the present climate and overflowed during moderate flow events. Note the phrase "in the present climate", because a floodplain can be abandoned and at least partly destroyed when climate becomes drier. An abandoned floodplain is called terrace.

Rivers, depending on the climate induced contribution of discharge and sediment form upstream, construct and maintain their channels. The channel at any place is of such a size that most sediment will be carried over a long period of time during those short periods when flow is near bankfull.

Thus, channels differ in shape depending not only on the size of the river but also on climatic-geologic setting. Because a river channel can also be characterized by a particular combination of shape and pattern parameters (channel slope or gradient, bed material, ratio of width to depth, amount or degree of meandering as defined by the value of sinuosity, and degree of confinement or constraint to lateral movement), a channel classification system is possible (Rosgen, 1994).⁷⁶

8.3.1 Adaptation of life to rivers

'Based on the energy equilibrium theory of fluvial geo-morphologists, Vannote et al. (1980) (in their River Continuum Concept) hypothesize that the structural and functional characteristics of stream communities are adapted to conform to the most probable position or mean state of the physical system. They reason that producer and consumer communities characteristic of a given river reach become established in harmony with the physical conditions of the river channel. Furthermore the authors theorize that biological communities developed in natural streams assume processing strategies involving minimum energy loss. The River Continuum Concept can almost be seen as a different wording of the Ecological Law of Thermodynamics applied to rivers, since it is fully compliant with it. The organization that is able to give the greatest distance away from thermodynamic equilibrium under the prevailing circumstances will be selected' (Jørgensen et al., 2007)

The main factors affecting life in rivers are flow velocity, temperature, oxygen and substrate, in ponds and lakes light, nutrients, oxygen, pH, temperature and turbulence.⁷⁷

8.3.2 Humans as drivers of change in river systems

Humans have changed the rivers as part of the physical landscapes all over the world since thousands of years with severe effects on their physical and biological properties (Brookes, 1988). Rivers are therefore among the most impacted ecosystems worldwide (Malmqvist and Rundle, 2002) and humans have been identified as *'the most important geomorphological factor'* (Demek 1973, from Brookes, 1985).

Furthermore with global climate change substantial changes in water availability, quality and flow can be expected (Houghton, 2005). *'Even greater impact is likely to occur because of increased frequency and intensity of extremes, especially floods and droughts. Such disasters are the most damaging disasters the world experiences; on average they cause more deaths, misery and economic loss than other disasters'* (Houghton, 2005).

⁷⁶ Ibid.

⁷⁷ <http://www.lifeinfreshwater.org.uk/Web%20pages/Abiotics/Factors.html>

Fig. 74 shows some major human impacts on the hydrological cycle. More information on human impacts on the other major nutrient cycles on earth can be found in Miller and Spoolman (2009).

On the other hand it has been realized that global human well-being strongly depends on ecosystem services provided by healthy riverine landscapes (Millennium Ecosystem Assessment, 2005). And this is why integrated river basin management has been recognized as one of the biggest challenges of the 21st century (UNESCO IHE⁷⁸).

A proper and integrative understanding on the factors governing river forms and processes, to which in turn all aquatic life is adopted locally, forms the basis for any successful long term management of rivers and all associated abiotic and biologic components on Earth.

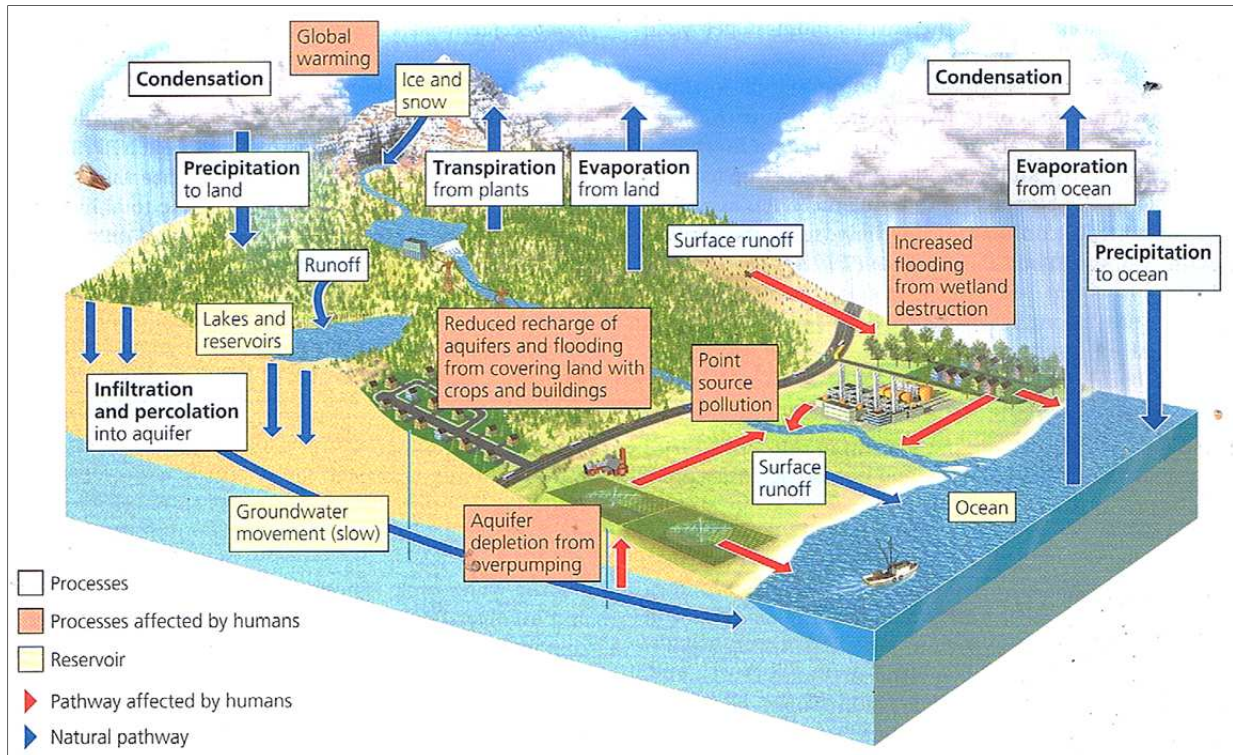
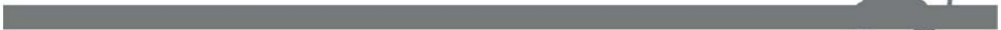

Figure 74: Simplified model of the hydrologic cycle with some harmful impacts of humans shown in red (Miller and Spoolman, 2009).

⁷⁸ <http://www.unesco-ihe.org/>



e-mail:

Info@DynaLearn.eu

website:

www.DynaLearn.eu

