



XD-9004A
GA-SWC-HB
04/09/2012

Simple. Smart.



XLT Gas Oven & AVI Hood Installation & Operation Manual



CAUTION

This appliance is for professional use by qualified personnel. This appliance must be installed by qualified persons in accordance with the regulations in force. This appliance must be installed with sufficient ventilation to prevent the occurrence of unacceptable concentrations of substances harmful to health in the room in which it is installed. This appliance needs an unobstructed flow of fresh air for satisfactory operation & must be installed in a suitably ventilated room in accordance with current regulations. This appliance should be serviced by qualified personnel at least every 12 months or sooner if heavy use is expected.

Current versions of this manual, Rough-In Specifications, Parts & Service Manual, Architectural Drawings, & a list of International Authorized Distributors are available at: www.xltovens.com

For use with the following XLT GAS Oven Versions:

Standard (S) C
World (W) C

For use with the following AVI Gas Hood Versions:

Standard (S) B
World (W) B



2000887

XLT Ovens
PO Box 9090
Wichita, Kansas 67277

US: 888-443-2751 FAX: 316-943-2769 INTL: 316-943-2751 WEB: www.xltovens.com

**SAFETY DEPENDS ON YOU****WARNING**

Improper installation, adjustment, alteration, service or maintenance can cause property damage, injury, or death. Read the installation, operating and maintenance instructions thoroughly before installing, using, or servicing this equipment.

- Post in a prominent location instructions to be followed in the event you smell gas. This information can be obtained by consulting your local gas supplier.

**WARNING****FOR YOUR SAFETY**

Do not store or use gasoline or other flammable liquids or vapors in the vicinity of this or any other appliance.

- In the event a gas odor is detected, shut off the gas at the main shutoff valve immediately. Contact your local Gas Company or supplier.
- Do not restrict the flow of combustion and/or ventilation air to the unit. Provide adequate clearance for operating, cleaning, & maintaining the unit & adequate clearance for operating the gas shutoff valve when the unit is in the installed position.
- Keep the area free & clear of combustible material. DO NOT SPRAY AEROSOLS IN THE VICINITY OF THIS APPLIANCE WHILE IT IS IN OPERATION.
- Ovens are certified for installation on combustible floors.
- Electrical schematics are located inside the control box of the oven & and in this manual. Disconnect input power to the unit before performing any maintenance.
- This unit requires a ventilation hood. The installation must conform to local codes.
- This unit may be operated with either natural gas or LP fuel as designated on the nameplate label located on the side of the unit.
- This unit must be operated by the same voltage, phase, & frequency of electrical power as designated on the nameplate label located on the side of the unit.
- Minimum clearances must be maintained from combustible & non-combustible construction materials.
- Follow all local codes when installing this unit.
- Follow all local codes to electrically ground the unit.
- Appliance is not to be cleaned with high pressure water.
- XLT ovens are certified for use in stacks of up to three (3) units of XLT products. Integration of other manufacturer's products into an oven stack is not recommended, & will void any warranties. XLT Ovens assumes no liability for mixed product applications.
- Failure to call XLT Customer Service at 1-888-443-2751 prior to contacting a repair company voids any & all warranties.
- PLEASE RETAIN THIS MANUAL FOR FUTURE REFERENCE.

XLT Ovens has spent millions of dollars designing and testing our products as well as developing Installation & Operation Manuals. These manuals are the most complete and easiest to understand in the industry. However, they are worthless if they are not followed.

We have witnessed store operators and building owners lose many thousands of dollars in lost revenue due to incorrect installations. We highly recommend you follow all instructions given in this manual as well as follow best practices in plumbing, electrical, and HVAC building codes.

Definitions & Symbols

A safety instruction (message) includes a “Safety Alert Symbol” & a signal word or phrase such as **WARNING** or **CAUTION**. Each signal word has the following meaning:



**HIGH
VOLTAGE**

This symbol indicates high voltage. It calls your attention to items or operations that could be dangerous to you & other persons operating this equipment. Read the message & follow the instructions carefully.



WARNING

Indicates a potentially hazardous situation that, if not avoided, can result in serious injury or death.



CAUTION

Indicates a potentially hazardous situation, that if not avoided, can result in minor to moderate injury or serious damage to the product. The situation described in the CAUTION may, if not avoided, lead to serious results. Important safety measures are described in CAUTION (as well as WARNING), so be sure to observe them.



NOTE

Notes indicate an area or subject of special merit, emphasizing either the product’s capability or common errors in operation or maintenance.



TIP

Tips give a special instruction that can save time or provide other benefits while installing or using the product. The tip calls attention to an idea that may not be obvious to first-time users of the product.

XLT warrants gas ovens manufactured after April 1, 2009 utilizing quietFIRE™ burners and all electric ovens manufactured after April 1, 2011 to be free from any defect in material and workmanship under normal use for five (5) years from the date of original purchase by the end user, and further warrants main fan blades, conveyor shafts, and conveyor bearings for ten (10) years. XLT further warrants all ovens to be free from rust for ten (10) years from the date the equipment is originally purchased. XLT warrants AVI hoods to be free from any defect in material and workmanship under normal use for two (2) years from the date of original purchase by the end user. In the event of a part failure, XLT will furnish a replacement part and pay for all labor associated with the replacement of the part if, upon inspection, XLT determines that the part is defective. This warranty is extended to the original end user purchaser and is not transferable without prior written consent of XLT. Damages are limited to the original purchase price.

DUTIES OF THE OWNER:

- The owner must inspect the equipment and crates at time of receipt. Damage during shipment is to be immediately reported to the carrier and also to XLT.
- The equipment must be installed and operated in accordance with the written instructions furnished with the unit.
- This warranty shall not excuse the owner from properly maintaining the equipment in accordance with the written instructions furnished with the unit.
- A copy of the “Initial Start-Up Checklist” must be filled out and returned to XLT Ovens and the Authorized Distributor when the unit is initially installed, and/or when the unit is removed and installed in another location.
- The gas, electric, and HVAC utilities must be connected to the oven and installed by locally licensed contractors.
- Failure to contact XLT Ovens prior to contacting a repair company for warranty work voids any and all warranties.

WHAT IS NOT COVERED:

The following items are not covered by this warranty:

- Freight damage
- Any part that becomes defective because of utility services (power surges, high or low voltages, high or low gas pressure or volume, contaminated fuel, or improper utility connections)
- Conveyor belts
- Filters
- Exhaust Fans
- Light Bulbs
- Normal maintenance or adjustments
- This warranty shall not apply if the equipment or any part is damaged as a result of accident, casualty, alteration, misuse, abuse, improper cleaning, improper installation, improper operation, natural disasters, or man-made disasters.

CLAIMS HANDLED AS FOLLOWS:

Should any such defect be discovered, XLT must be notified. Upon notification, XLT will arrange for necessary repairs to be made by an authorized service agent. Denial of services upon the arrival of an authorized service agent will release XLT of any and all warranty obligations.

XLT warrants gas ovens manufactured after January 1, 2011 utilizing quietFIRE™ burners and all electric ovens manufactured after April 1, 2011 to be free from any defect in material and workmanship under normal use for two (2) years from the date of original purchase by the end user. XLT warrants AVI hoods to be free from any defect in material and workmanship under normal use for one (1) year from the date of original purchase by the end user. In the event of a part failure, XLT will furnish a replacement part to the Authorized Dealer if, upon inspection, XLT determines that the part is defective. The Authorized Dealer will pay for all labor associated with the replacement of the part. This warranty is extended to the original end user purchaser and is not transferable without prior written consent of XLT. Damages are limited to the original purchase price.

DUTIES OF THE OWNER:

- The owner must inspect the equipment and crates at time of receipt. Damage during shipment is to be immediately reported to the carrier and also to XLT.
- The equipment must be installed and operated in accordance with the written instructions furnished with the unit.
- This warranty shall not excuse the owner from properly maintaining the equipment in accordance with the written instructions furnished with the unit.
- A copy of the “Initial Start-Up Checklist” must be filled out and returned to XLT Ovens and the Authorized Dealer when the unit is initially installed, and/or when the unit is removed and installed in another location.
- The gas, electric, and HVAC utilities must be connected to the oven and installed by locally licensed contractors.
- Failure to contact the Authorized Dealer prior to contacting a repair company for warranty work voids any and all warranties.

WHAT IS NOT COVERED:

The following items are not covered by this warranty:

- Freight damage
- Any part that becomes defective because of utility services (power surges, high or low voltages, high or low gas pressure or volume, contaminated fuel, or improper utility connections)
- Conveyor belts
- Filters
- Exhaust Fans
- Light Bulbs
- Normal maintenance or adjustments
- This warranty shall not apply if the equipment or any part is damaged as a result of accident, casualty, alteration, misuse, abuse, improper cleaning, improper installation, improper operation, natural disasters, or man-made disasters.

CLAIMS HANDLED AS FOLLOWS:

Should any such defect be discovered, the Authorized Dealer must be notified. Upon notification, the Authorized Dealer will arrange for necessary repairs to be made by an authorized service agent. The Authorized Dealer will notify XLT Ovens of all discovered defects.

NOTIFY CARRIER OF DAMAGE AT ONCE

Upon receiving of all goods shipped by a Common Carrier, check for any exterior damage that may indicate interior damage. If conditions permit, open all crates & do a full inspection for any damage while the delivery driver is still there. If there is damage, please note on the delivery receipt & call the carrier to make a freight damage claim within 24 hours of receipt. Failure to make a damage claim within the first 24 hours may void the opportunity to have the claim resolved.

XLT Ovens wants you to be totally satisfied with every aspect of owning & using your oven & hood. Your feedback, both positive & negative, is very important to us as it helps us understand how to improve our products & our company. Our goal is to provide you with equipment that we can be proud to build & you can be proud to own.

To receive technical support for the oven or hood you purchased, XLT has qualified customer service personnel that can provide assistance on any type of XLT oven problem you may experience. Customer Service is available 24/7/365 or visit www.xltovens.com.

**WARNING**

Installation of all gas appliances & ventilation exhaust hoods should only be performed by a qualified professional who has read & understands these instructions & is familiar with proper safety precautions. Read this manual thoroughly before installing or servicing this equipment.

Save this Manual

This document is the property of the owner of this equipment.

XLT Ovens reserves the right to make changes in design & specifications, and/or make additions to or improvements to its product without imposing any obligations upon itself to install them in products previously manufactured.

All Right Hand & Left Hand designations in this manual are from the point of view as if standing directly in front of the glass sandwich door.

Revision History Table		
Revision	Comments	Date
A	New Release	04/09/2012

Warning & Safety Information..... 2

Warranty..... 4

Oven & Hood Descriptions 8

Oven Dimensions & Weights..... 10

Oven Gas Requirements..... 12

Oven Electrical Requirements..... 16

Oven Only Rough-In Specifications 17

Oven Assembly 18

Oven Installation 23

Oven Fire Suppression 25

Oven Ventilation Requirements & Guidelines..... 27

Oven Initial Start-Up..... 28

Oven Operation 29

Oven Operator Controls 30

Oven Cleaning..... 31

Oven Maintenance..... 35

Oven Troubleshooting..... 36

Hood Description 39

Hood Dimensions & Weights..... 40

Hood Electrical Requirements..... 42

Hood Electrical Connections..... 44

Hood Rough-In Specifications 57

Hood Exhaust Flow Rates 58

Hood Installation 60

Hood Initial Start-Up..... 79

Hood Operator Controls 80

Hood Valance Kit..... 81

Hood Duct Wrap Kit 84

Hood Cleaning..... 85

Hood Troubleshooting..... 86

Variable Frequency Drive Manual Mode..... 87

Electrical Schematics 88

Certifications 97

Oven Start-Up Checklist 99

Hood Start-Up Checklist 101

This manual covers the following XLT Oven & AVI Hood models:

Ovens		Hoods	
Standard	World	Standard	World
XLT-1832C-S	XLT-1832C-W	AVI-1832B-S	AVI-1832B-W
XLT-2440C-S	XLT-2440C-W	AVI-2440B-S	AVI-2440B-W
XLT-3240C-S	XLT-3240C-W	AVI-3240B-S	AVI-3240B-W
XLT-3255C-S	XLT-3255C-W	AVI-3255B-S	AVI-3255B-W
XLT-3270C-S	XLT-3270C-W	AVI-3270B-S	AVI-3270B-W
XLT-3855C-S	XLT-3855C-W	AVI-3855B-S	AVI-3855B-W
XLT-3870C-S	XLT-3870C-W	AVI-3870B-S	AVI-3870B-W

The first 2 digits of the model number represent the conveyor width and the last two digits indicate the bake chamber length. The ovens may be used in a single, double, or triple oven stack configuration. All ovens are gas-fired & are available in Natural gas or LP gas models (Electric ovens are also available). The 3270 & 3870 models have two burners, one on each side, & have two control boxes. All other models have only a single burner with a single control box that can be supplied on either end. All models can be configured for a split belt conveyor.

OVEN DESCRIPTION

Food product is placed on the stainless steel wire conveyor belt on one side of the oven. The conveyor then transports the food through the bake chamber at a user-controlled speed. This provides repeatable and uniform food cooking. The conveyors can be easily configured to move either left-to-right or right-to-left. A large center sandwich door allows the introduction or removal of food items for cooking at shorter times. Precise temperatures are user adjustable and maintained by a digital control.

An easily removable front panel allows the full cleaning of the oven interior. All exposed oven surfaces both exterior and interior are stainless steel. The conveyor is a one piece design and is removed from the side which has the control box. No tools are required for disassembly and cleaning of the conveyor or oven interior. The oven itself is mounted on lockable swivel casters for easy moving and maintenance.

Accessories such as extended conveyor shelves, base shelves, cool fronts, fire suppression components, and perforated crumb trays are available from XLT. In addition, moving equipment such as carts and lifting jacks are available to help install and move ovens. Please contact XLT Ovens or your Authorized Distributor for more information.

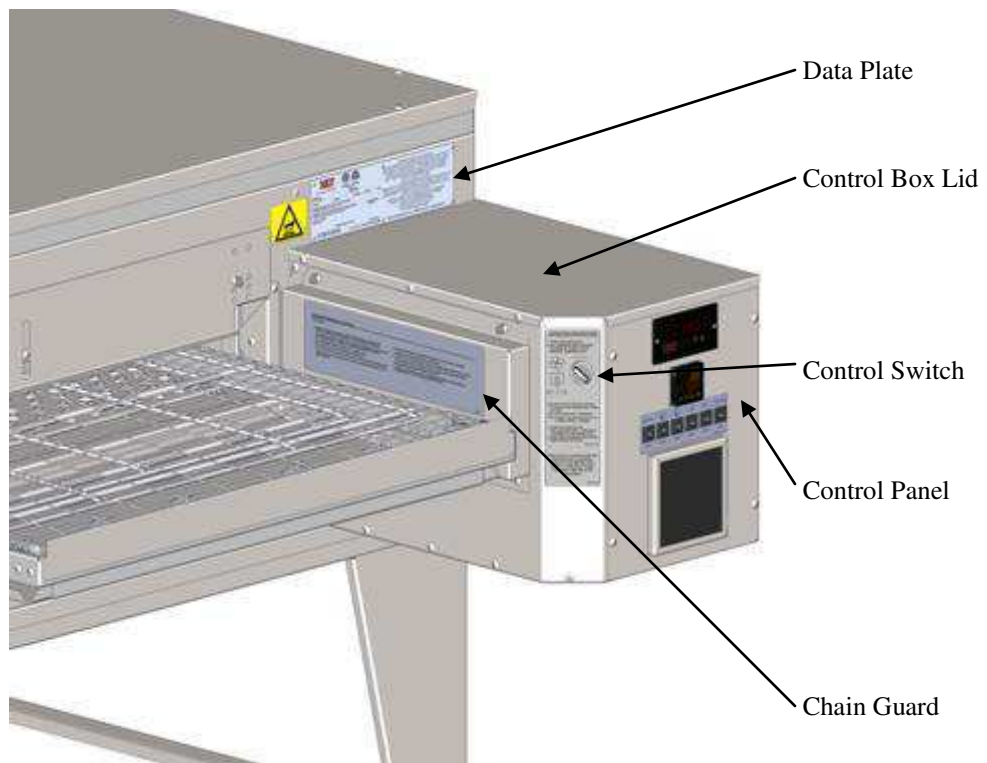
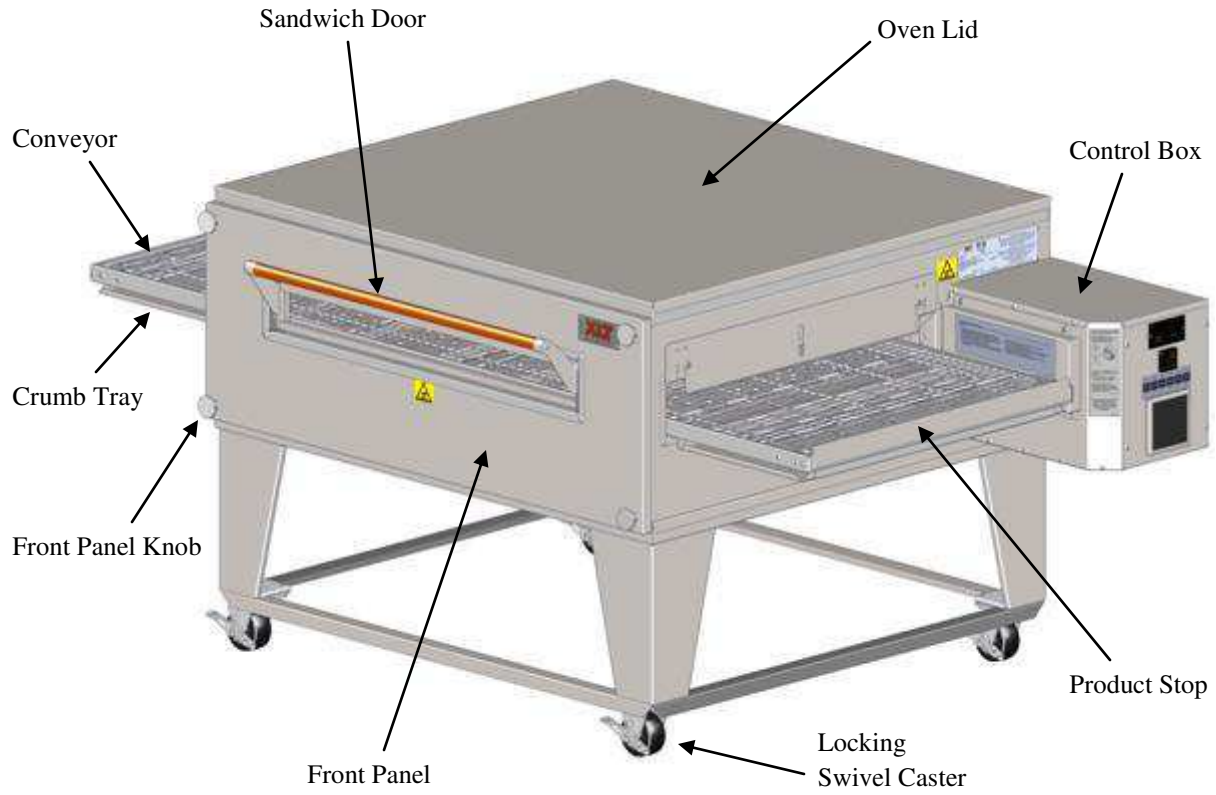

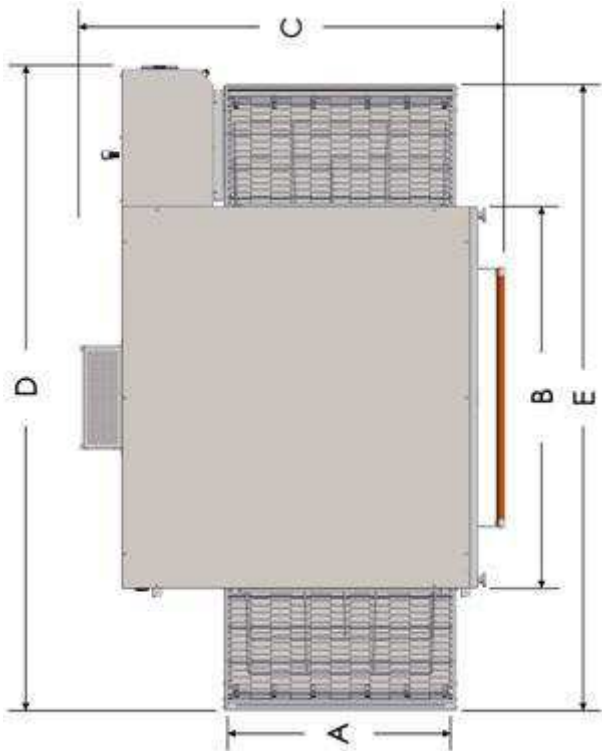
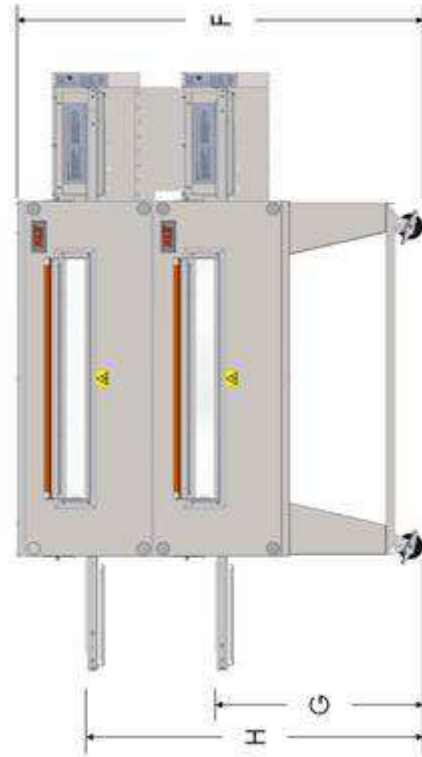
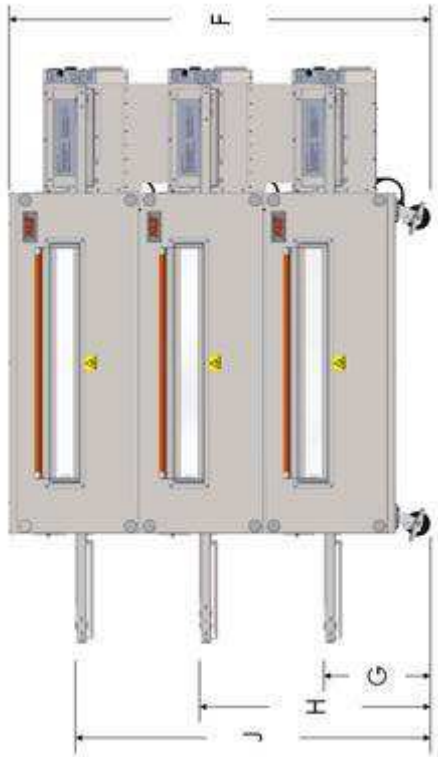

OVEN DIMENSIONS & WEIGHTS

NOTE: All dimensions in inches [millimeters], ± 1/4 [6], unless otherwise noted. All weights in pounds [kilograms] unless otherwise noted.

SINGLE STACK	A	B	C	D	E	F	G	H	J	WEIGHT
1832	18 [457]	32 [813]	47 1/4 [1200]	70 [1778]	67 1/4 [1708]	42 3/4 [1086]	32 [813]	N/A	N/A	477 [216]
2440	24 [610]	40 [1016]	53 1/4 [1353]	78 [1981]	75 1/4 [1911]	42 3/4 [1086]	32 [813]	N/A	N/A	543 [246]
3240	32 [813]	40 [1016]	61 1/4 [1556]	78 [1981]	75 1/4 [1911]	42 3/4 [1086]	32 [813]	N/A	N/A	629 [285]
3255	32 [813]	55 [1397]	61 1/4 [1556]	93 [2362]	90 1/4 [2292]	42 3/4 [1086]	32 [813]	N/A	N/A	757 [343]
3270	32 [813]	70 [1778]	61 1/4 [1556]	110 3/4 [2813]	105 1/4 [2673]	42 3/4 [1086]	32 [813]	N/A	N/A	985 [447]
3855	38 [965]	55 [1397]	67 1/4 [1708]	93 [2362]	90 1/4 [2292]	42 3/4 [1086]	32 [813]	N/A	N/A	829 [376]
3270	38 [965]	70 [1778]	67 1/4 [1708]	110 3/4 [2813]	105 1/4 [2673]	42 3/4 [1086]	32 [813]	N/A	N/A	1077 [489]
DOUBLE STACK	A	B	C	D	E	F	G	H	J	WEIGHT
1832	18 [457]	32 [813]	47 1/4 [1200]	70 [1778]	67 1/4 [1708]	62 3/4 [1594]	32 [813]	52 [1321]	N/A	863 [391]
2440	24 [610]	40 [1016]	53 1/4 [1353]	78 [1981]	75 1/4 [1911]	62 3/4 [1594]	32 [813]	52 [1321]	N/A	981 [445]
3240	32 [813]	40 [1016]	61 1/4 [1556]	78 [1981]	75 1/4 [1911]	62 3/4 [1594]	32 [813]	52 [1321]	N/A	1142 [518]
3255	32 [813]	55 [1397]	61 1/4 [1556]	93 [2362]	90 1/4 [2292]	62 3/4 [1594]	32 [813]	52 [1321]	N/A	1380 [626]
3270	32 [813]	70 [1778]	61 1/4 [1556]	110 3/4 [2813]	105 1/4 [2673]	62 3/4 [1594]	32 [813]	52 [1321]	N/A	1817 [824]
3855	38 [965]	55 [1397]	67 1/4 [1708]	93 [2362]	90 1/4 [2292]	62 3/4 [1594]	32 [813]	52 [1321]	N/A	1513 [686]
3870	38 [965]	70 [1778]	67 1/4 [1708]	110 3/4 [2813]	105 1/4 [2673]	62 3/4 [1594]	32 [813]	52 [1321]	N/A	1984 [900]
TRIPLE STACK	A	B	C	D	E	F	G	H	J	WEIGHT
1832	18 [457]	32 [813]	47 1/4 [1200]	70 [1778]	67 1/4 [1708]	67 3/4 [1721]	17 [432]	37 [940]	57 [1448]	1216 [552]
2440	24 [610]	40 [1016]	53 1/4 [1353]	78 [1981]	75 1/4 [1911]	67 3/4 [1721]	17 [432]	37 [940]	57 [1448]	1386 [629]
3240	32 [813]	40 [1016]	61 1/4 [1556]	78 [1981]	75 1/4 [1911]	67 3/4 [1721]	17 [432]	37 [940]	57 [1448]	1617 [733]
3255	32 [813]	55 [1397]	61 1/4 [1556]	93 [2362]	90 1/4 [2292]	67 3/4 [1721]	17 [433]	37 [941]	57 [1448]	1964 [891]
3270	32 [813]	70 [1778]	61 1/4 [1556]	110 3/4 [2813]	105 1/4 [2673]	67 3/4 [1721]	17 [433]	37 [941]	57 [1448]	2610 [1184]
3855	38 [965]	55 [1397]	67 1/4 [1708]	93 [2362]	90 1/4 [2292]	67 3/4 [1721]	17 [433]	37 [941]	57 [1448]	2156 [978]
3870	38 [965]	70 [1778]	67 1/4 [1708]	110 3/4 [2813]	105 1/4 [2673]	67 3/4 [1721]	17 [433]	37 [941]	57 [1448]	2846 [1291]

All values shown this page are per each oven

Gas Oven Heating Values & Orifice Sizes										
Oven Model	Heating Values				Orifice Sizes					
	Australian		Standard & World		Australian		Standard & World			
	All Fuels				NAT	LP	NAT		LP	
	MJ/HR	KW/HR	BTU/HR	KW/HR	MM	MM	Inches	MM	Inches	MM
1832	63	17.5	47,700	13.97	3.56	2.24	0.125	3.18	0.081	2.06
2440	79	22.0	67,200	19.68	3.96	2.44	0.144	3.66	0.089	2.26
3240	105	29.2	96,100	28.14	4.62	2.79	0.170	4.32	0.113	2.87
3255	169	47.0	119,900	35.11	5.94	3.66	0.191	4.85	0.116	2.95
3270	190	52.8	140,800	41.23	4.39	2.64	0.144	3.66	0.096	2.44
3855	169	47.0	142,200	41.64	5.94	3.66	0.209	5.31	0.125	3.18
3870	190	52.8	137,900	40.38	4.39	2.64	0.144	3.66	0.096	2.44

Gas Oven Fuel Pressure Requirements												
Oven Models	Inlet Pressure Range						Manifold Pressure					
	Natural Gas			LP Gas			Natural Gas			LP Gas		
	W/C	mbar	kPa	W/C	mbar	kPa	W/C	mbar	kPa	W/C	mbar	kPa
All	6-14	15-35	1.5-3.5	11.5-14	27.5-35.0	2.75-3.50	3.5	8.75	0.875	10	25	2.5

World Oven Gas Group								
Gas Group	Natural Gas				Propane Gas			
	I _{2H}	I _{2E}	I _{2E+}	I _{2L}	I ₃₊	I _{3B/P (30)}	I _{3P (30/37/50)}	I _{3B (37)}
Inlet pressure (mbar)	20	20	20/25	25	28/30/37/50	28-30/37/50	30/37/50	37
Number of injectors	(1) per burner							
Main burner opening size	Fixed							
Ignition	Electric Direct Spark Igniter							
Inlet connection	BSP 3/4" male thread							

Gas Matrix by Country								
Country	Symbol	Natural Gas (8.75 mbar manifold)				LP Gas (25 mbar manifold)		
		I _{2H}	I _{2L}	I _{2E}	I _{2E+}	I _{3B/P}	I ₃₊	I _{3P}
Austria	AT	X				X		
Belgium	BE				X		X	
Cyprus	CY					X	X	X
Czech Republic	CZ	X				X		
Denmark	DK	X				X		
Estonia	EE	X						
Finland	FI	X				X		
France	FR				X	X	X	X
Germany	DE			X		X		X
Greece	GR	X						
Hungary	HU					X		X
Iceland	IS							
Ireland	IE	X					X	X
Italy	IT	X					X	
Latvia	LT					X		
Lithuania	LV							
Luxembourg	LU							
Malta	MT					X		X
Netherlands	NL		X			X		X
Norway	NO					X		
Poland	PL			X				
Portugal	PT	X					X	X
Slovakia	SK					X		
Slovenia	SI	X						
Spain	ES	X					X	X
Sweden	SE	X				X		
Switzerland	CH	X				X	X	X
United Kingdom	GB	X					X	X

Gas Supply Requirements for Australian, Standard. & World Ovens

➔ All installations must conform to local building & mechanical codes.

NOTE

1. The gas supply shall have a gas meter & regulator large enough to handle **ALL** of the gas appliances, such as the furnace, water heater, & ovens in operation at the same time. Add up all of the Btu/kw/MJ ratings to determine the total load.
2. The gas supply shall have a separate gas meter and gas pressure regulator for each occupant. Installations in multiple occupancy buildings, (strip malls) shall not share gas meters and regulators with other occupants.
3. Gas hose assemblies with quick disconnects for each oven deck will be installed at each valve.
4. A sediment trap shall be installed downstream of the equipment shutoff valve as close to the inlet of the appliance as practical at the time of appliance installation. The sediment trap shall be either a tee fitting with a capped nipple in the bottom outlet as illustrated, and in accordance with ANSI Z223.1-2012 and NFPA 54-2012 National Fuel Gas Code, section 9.6.7.

Item #	Description
1	1-½ [40] Shut-Off Valve
2	¾ [20] Shut-Off Valve
3	6 [150] Nipple
4	¾ [20] Nipple
5	Reducing Tee
6	Tee
7	Cap
8	Plug

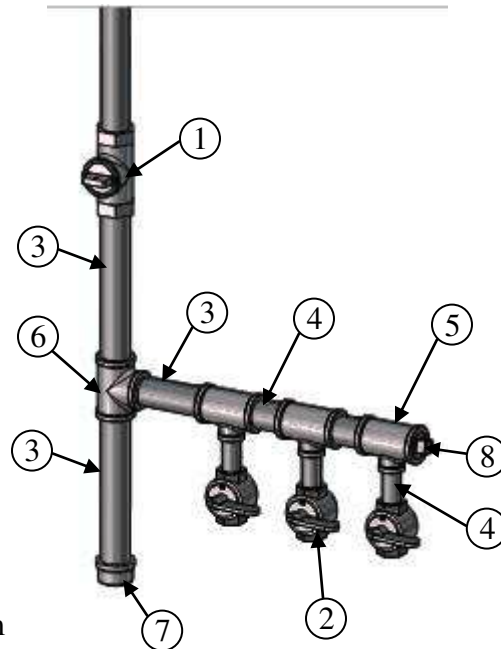

➔ All pipe fittings to be 1-½ [40] minimum unless noted. NPT & BSP

NOTE



CAUTION

Do not use Teflon tape on gas line connections as this can possibly cause gas valve malfunction or plugging of orifices from shreds of tape. Use of Teflon tape may affect warranty.

Gas Supply Testing Requirements

1. The appliance & its individual shutoff valve must be **disconnected** from the gas supply piping system during any pressure testing of that system at test pressures in **excess** of 3.5 kPa or ½-psi.
2. The appliance must be **isolated** from the gas supply piping system by closing its individual manual shutoff valve during any pressure testing of the gas supply piping system at test pressures **equal to or less than** 3.45 kPa or ½-psi.

Gas Hose Requirements

- For Australia, if installing with a flexible hose assembly, the assembly must be certified to AS/NZS 1869, & be Class B or D.
- For Standard Ovens, if installing with a flexible gas hose, the installation must comply with either ANSI Z21.69 or CAN/CGA-6.16 & a disconnect device complying with either ANSI Z21.41 or CAN-6.9.
- The installation must conform with local building codes, or in the absence of local codes, with the National Fuel Gas Code, ANSI Z223.1, latest version, Natural Gas Installation Code, CAN/CGA-B149.1, or the Propane Installation Code, CAN/CGA-B149.2, as applicable.

All values shown this page are per each oven

Gas Oven Electrical Requirements						
Per EACH Oven						
Oven Model	STANDARD			WORLD		
	Volts AC	Amps	Hertz	Volts AC	Amps	Hertz
1832	120 VAC 1Φ	6	60	220/230/ 240 VAC 1Φ	3	50
2440		6			3	
3240		6			3	
3255		6			3	
3270		12			6	
3855		6			3	
3870		12			6	

FOR EACH OVEN:

- A separate circuit breaker must be provided for each oven deck.
- Electrical connections must be accessible when the ovens are in the installed position.
- Electrical connections must meet all local code requirements.

Standard Ovens

Electrical Grounding Instructions

This appliance is equipped with a three-prong (grounding) plug for your protection against shock hazard & should be plugged into a properly grounded three-prong receptacle. Do not cut or remove the grounding prong from this plug.



**HIGH
VOLTAGE**

When installed, the appliance must be electrically grounded in accordance with local codes, or in the absence of local codes, with the National Electrical Code, ANSI/NFPA 70, or the Canadian Electrical Code, CSA C22.2, as applicable.

World Ovens

- This appliance is equipped with a ground lug for your protection against shock hazard & must be properly grounded.
- When installed, the appliance must be electrically grounded in accordance with local codes.

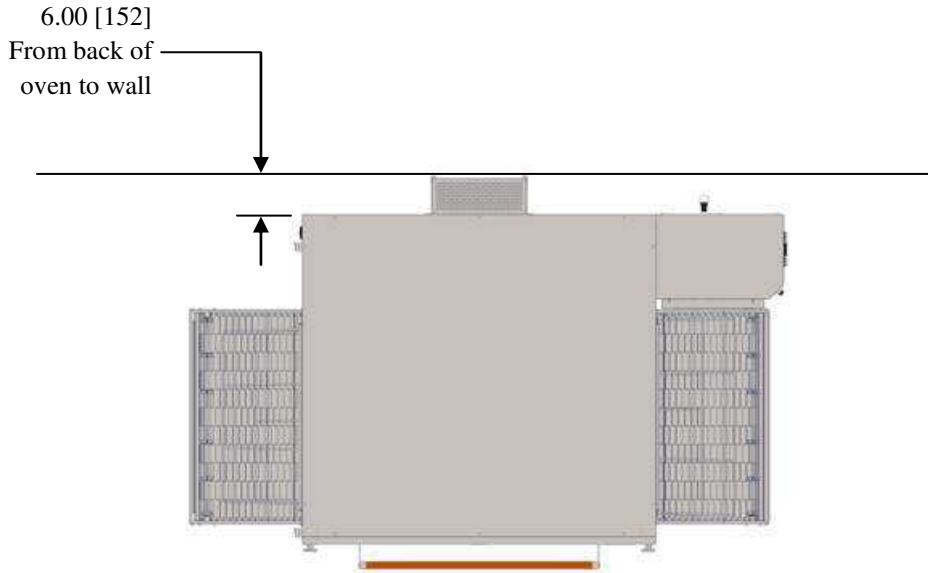

NOTE Utilities must be easily accessible when the ovens are in the installed position. Do not install utilities behind the ovens.

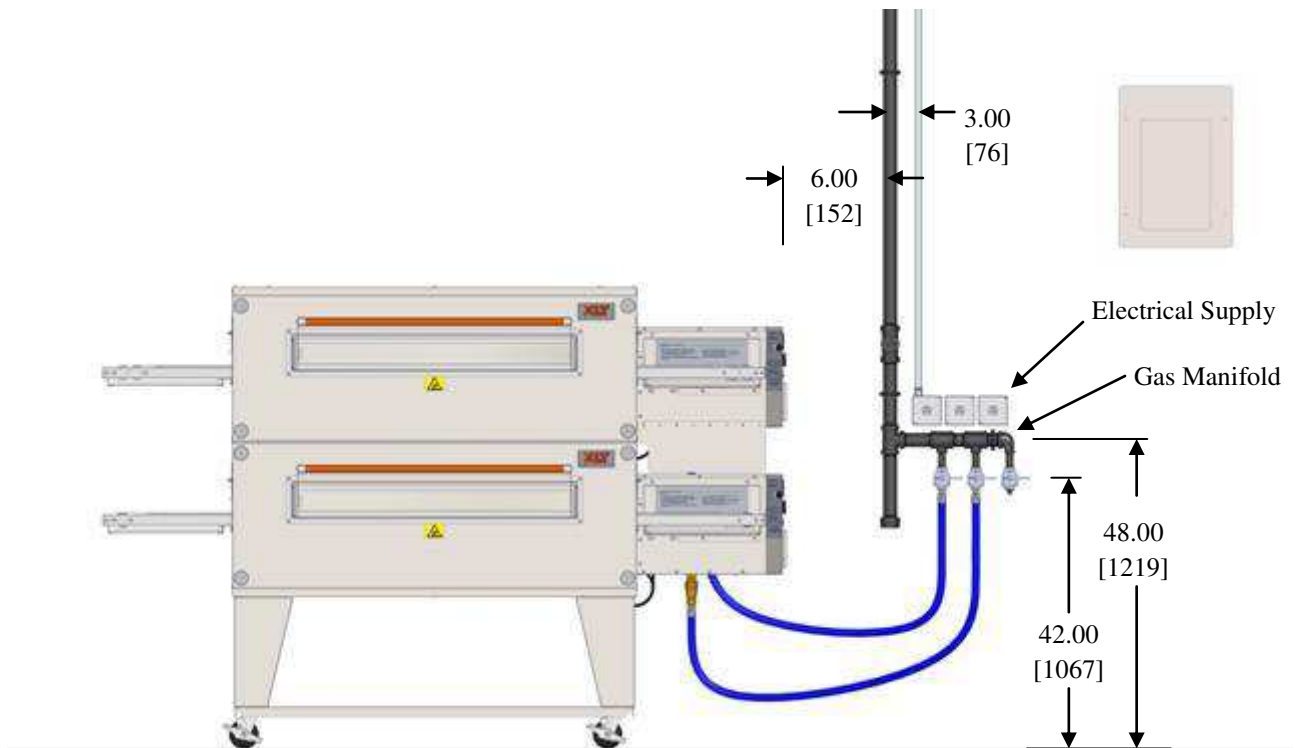

NOTE All installations must conform to local building and mechanical codes. It is required that the ovens be placed under a ventilation hood to provide exhaust ventilation and adequate air supply.

OVEN ASSEMBLY

Base Assembly - Triple Stack

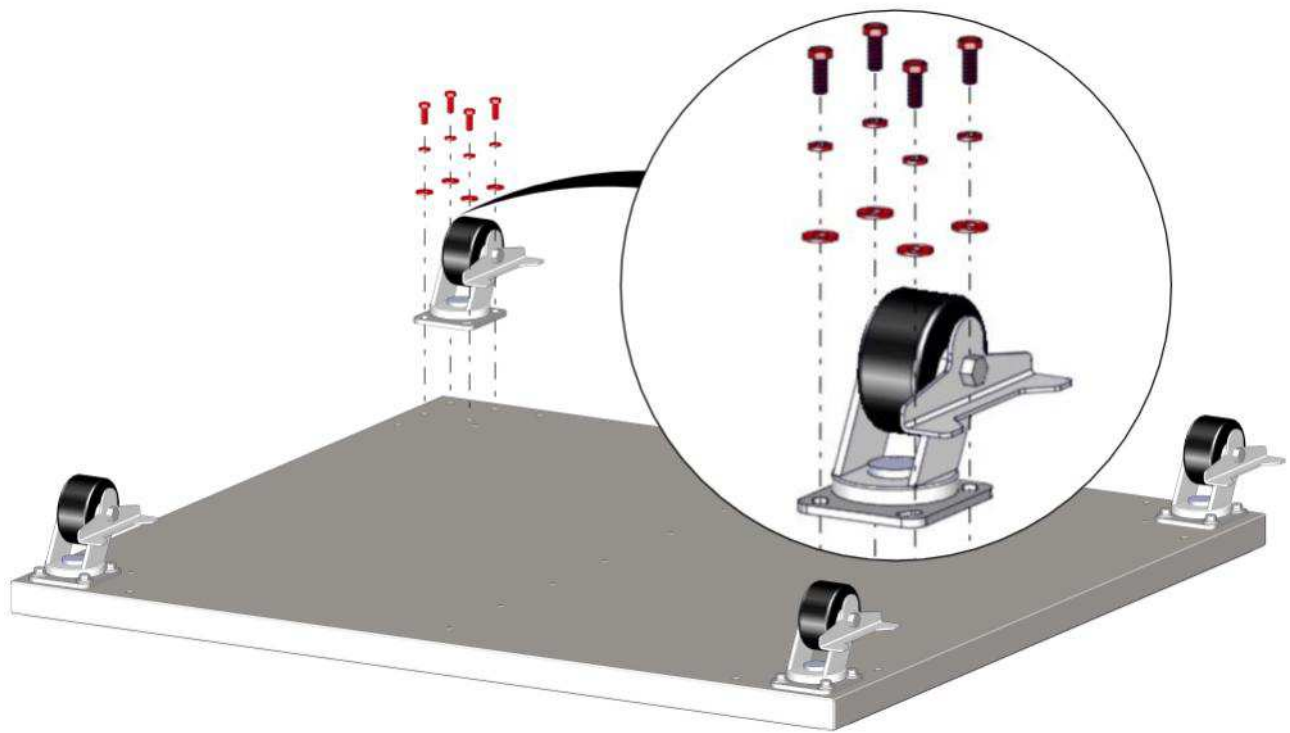

Base Assembly - Single & Double Stack

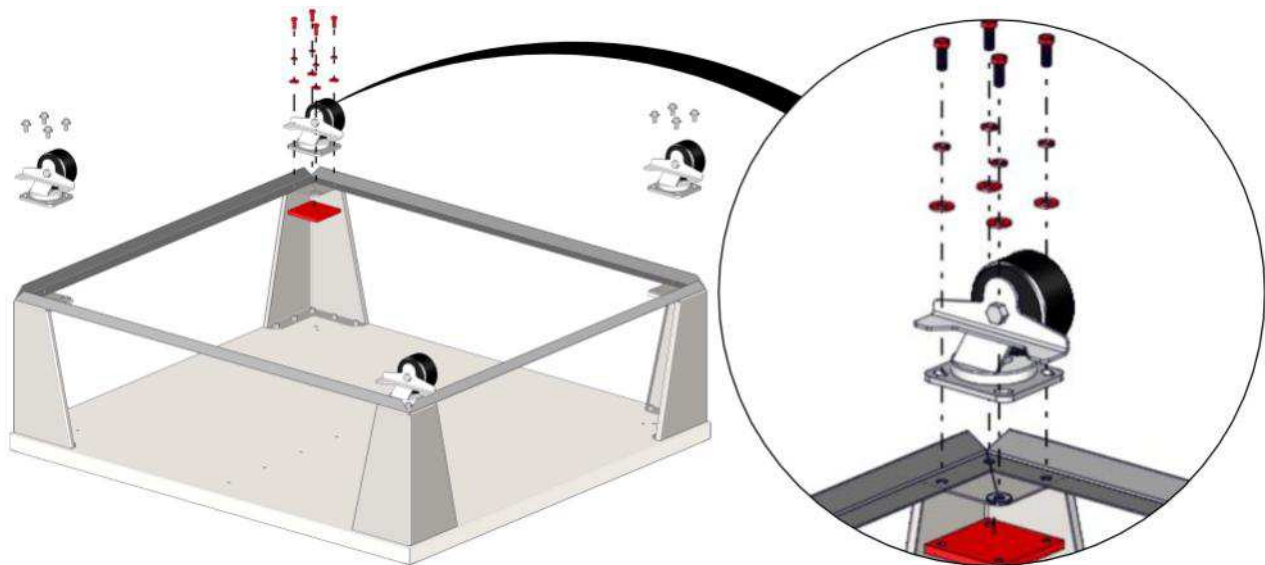
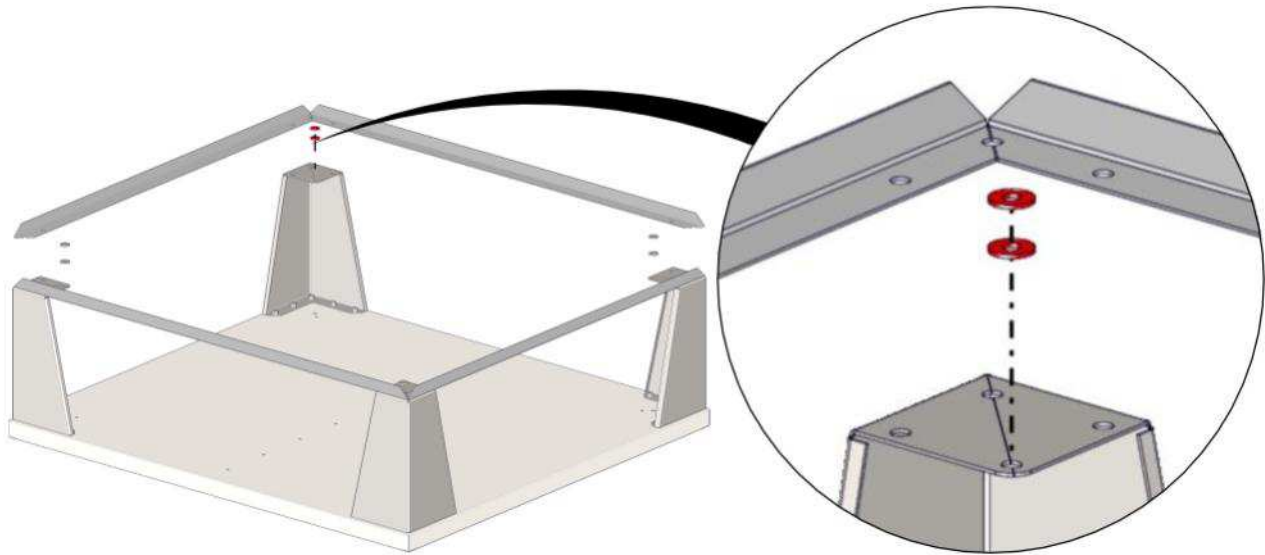
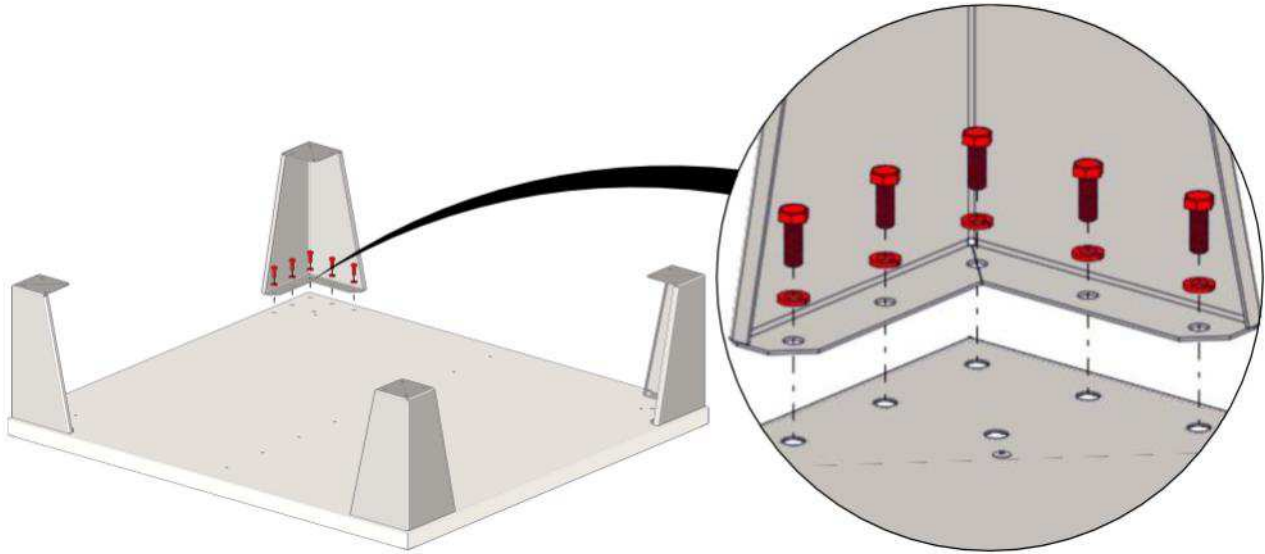

WARNING & SAFETY INFORMATION

XLT ovens can easily be moved and stacked with the proper lifting equipment. The use of XLT approved lifting equipment is highly recommended. Contact XLT for more information.



WARNING

- These ovens are heavy & can tip or fall causing bodily injury.
- NEVER place any part of your body beneath any oven that is suspended by the lifting jacks. A crush hazard exists if the oven falls or slips.
- DO NOT place your hands on the lifting jack vertical pole beneath the jack's winch. As the jack's winch descends when you turn the jack handle, a pinch point is created between the winch & the pole.



CAUTION

BE CAREFUL when rolling the oven on the cart, especially when going up or down ramps & over bumps. Leave the straps/banding on until the oven is near the assembly area.



WARNING

- Make sure that the notch on tube of the winch assembly is aligned with the pin in the tripod base as shown. These alignments are important and keep the jack aligned properly.
- Check for smooth operation. The cable should not be pinched and should pass smoothly over the pulley on top of the pole assembly.
- Inspect cable prior to each use.
- If cable is frayed or shows signs of excessive wear and tear, DO NOT USE until cable is replaced.
- At a minimum replace the cable annually with wire rope that meets or exceeds the jack manufacturer's specifications.
- Do not exceed the stated capacity of the jack.



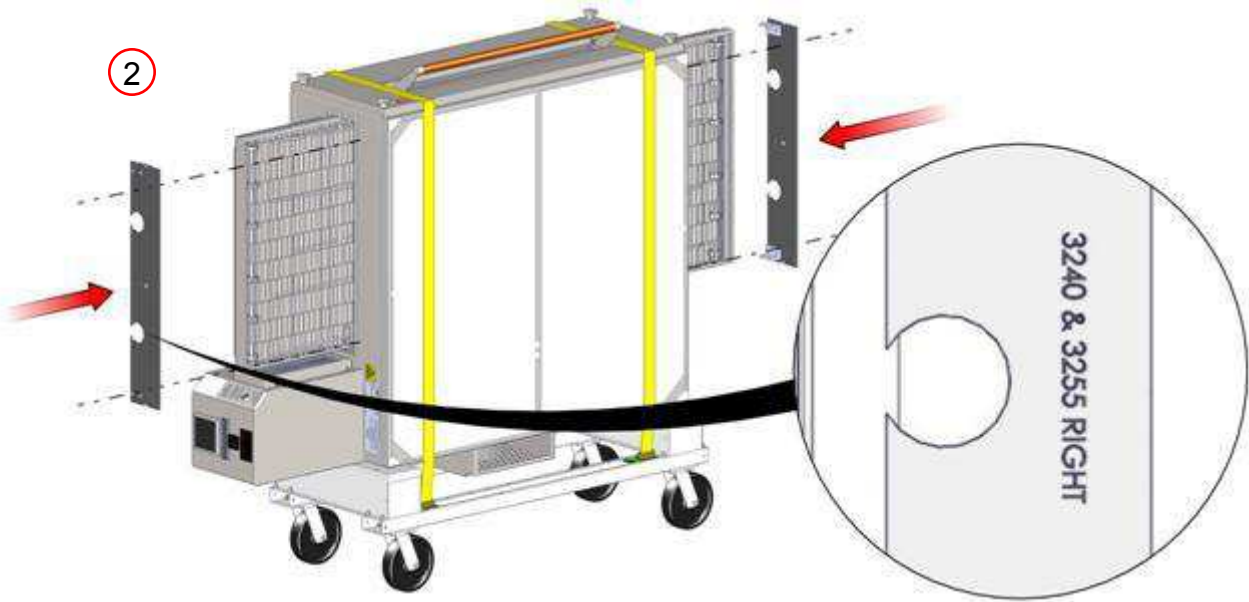

NOTE → The Lifting Pipe hole, marked for the appropriate oven size, must be installed closest to the control box.



Stacking the Ovens

**WARNING**

Failure to engage the Lifting Jacks into the Lifting Pipe properly and completely will result in damage, injury, or death from a falling oven.

**WARNING**

- Both jacks should be raised in unison, otherwise they may bind and a dangerous situation will develop.
- Do not put any part of yourself under the oven at any time.
- The Oven is top heavy. Be careful.

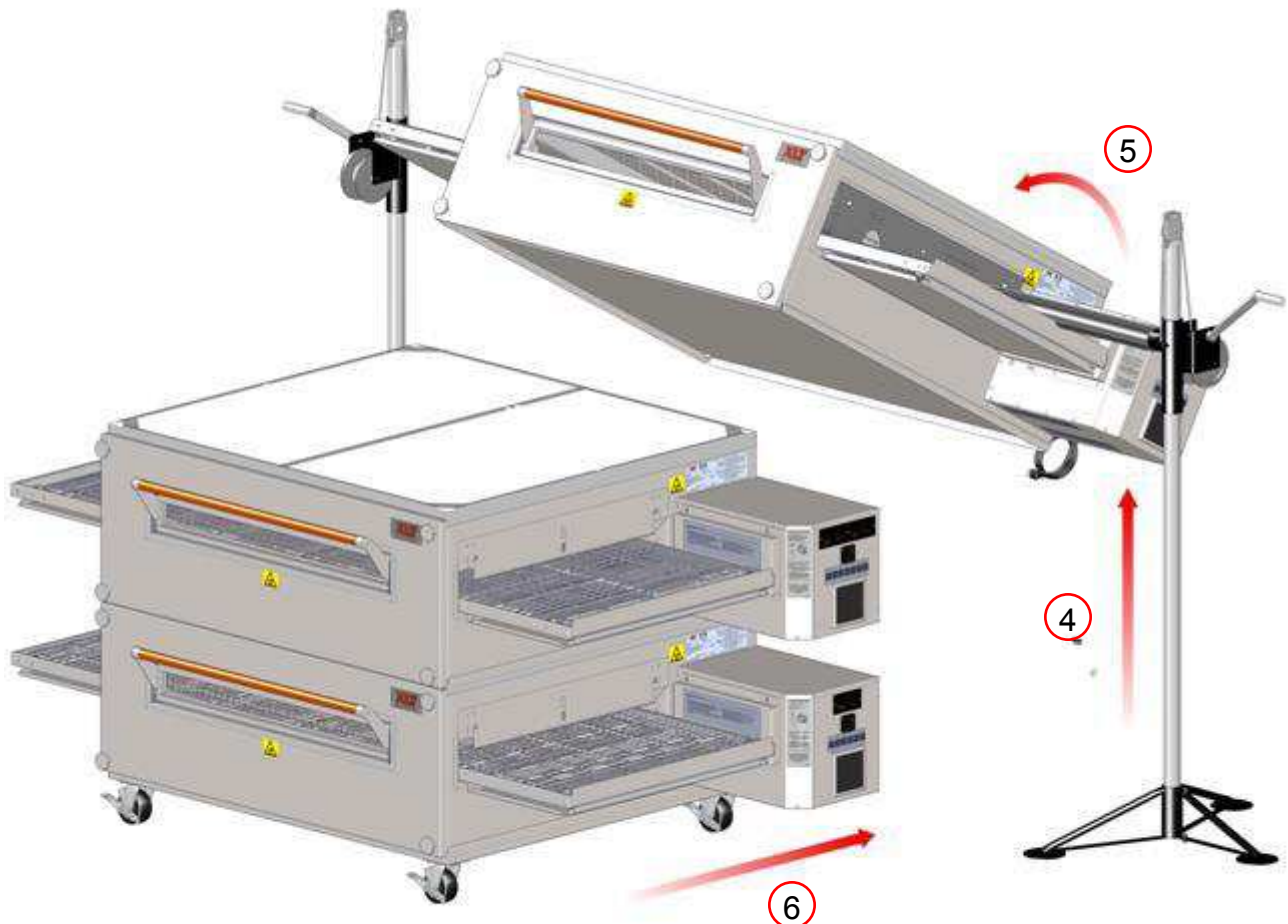

Stacking the Ovens

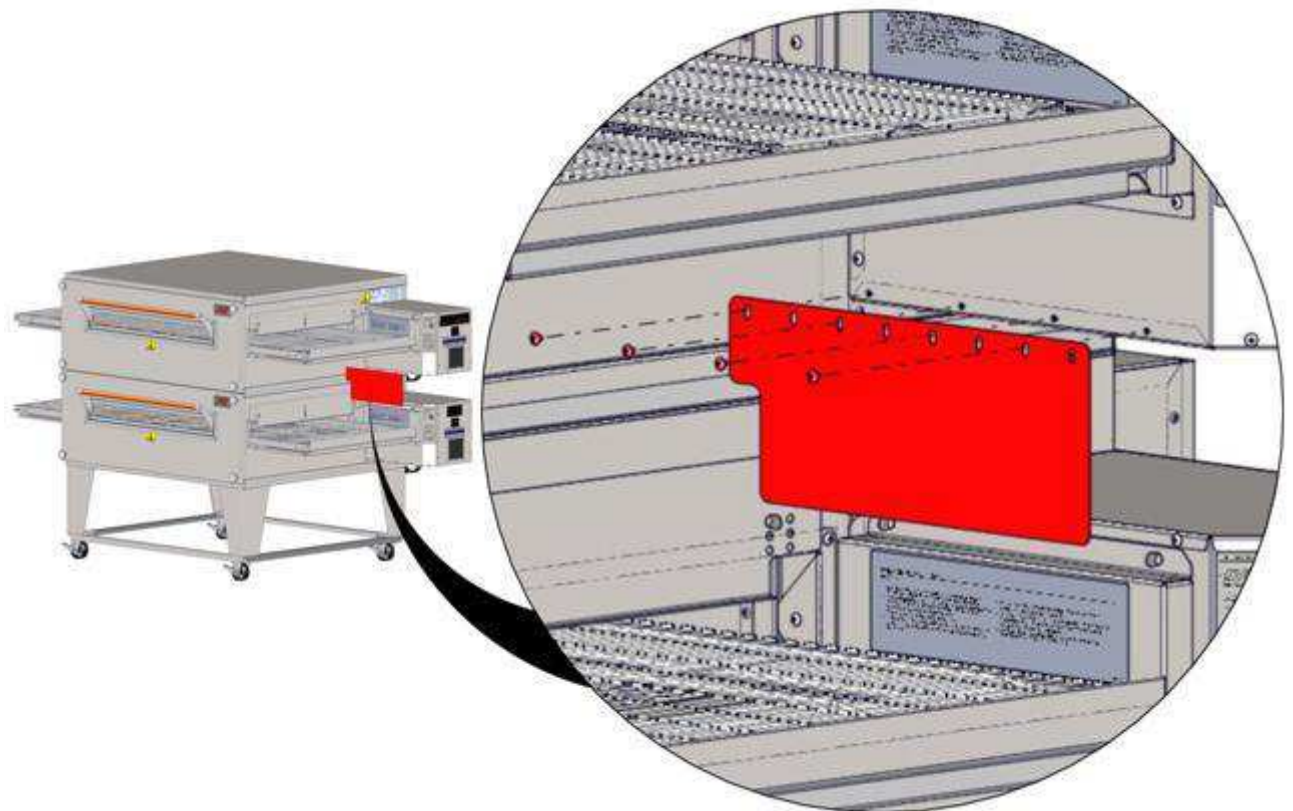

Physical Location & Spacing Requirements

These ovens are suitable for installation on either combustible or non-combustible floors, and adjacent to either combustible or non-combustible walls. The motor cover is designed to provide the proper clearance to the back of the oven. The minimum side clearances are 6in. / 150mm, measured from the end of the conveyor.

 **All installations must conform to local building and mechanical codes.**

NOTE

Restraint

Because all ovens are equipped with casters, all installations must be configured with a restraint to limit the movement of the oven without depending on the electric power supply cord or gas hose to limit the oven movement. One (1) restraint kit, which includes one (1) eye bolt, (1) stainless steel clip & a cable, is required for each oven stack, regardless if used on a single, double, or triple configuration. The clip should be installed in the lowest hole of the back wall on the control end of the lowest oven in the stack. The lag eye bolt must be installed into a structural member of a wall or the floor. It is the owner's responsibility to ensure the restraint is installed correctly.

Upon completion of performing any service or cleaning functions that require removal of the restraint, insure that it is correctly re-attached to the oven.

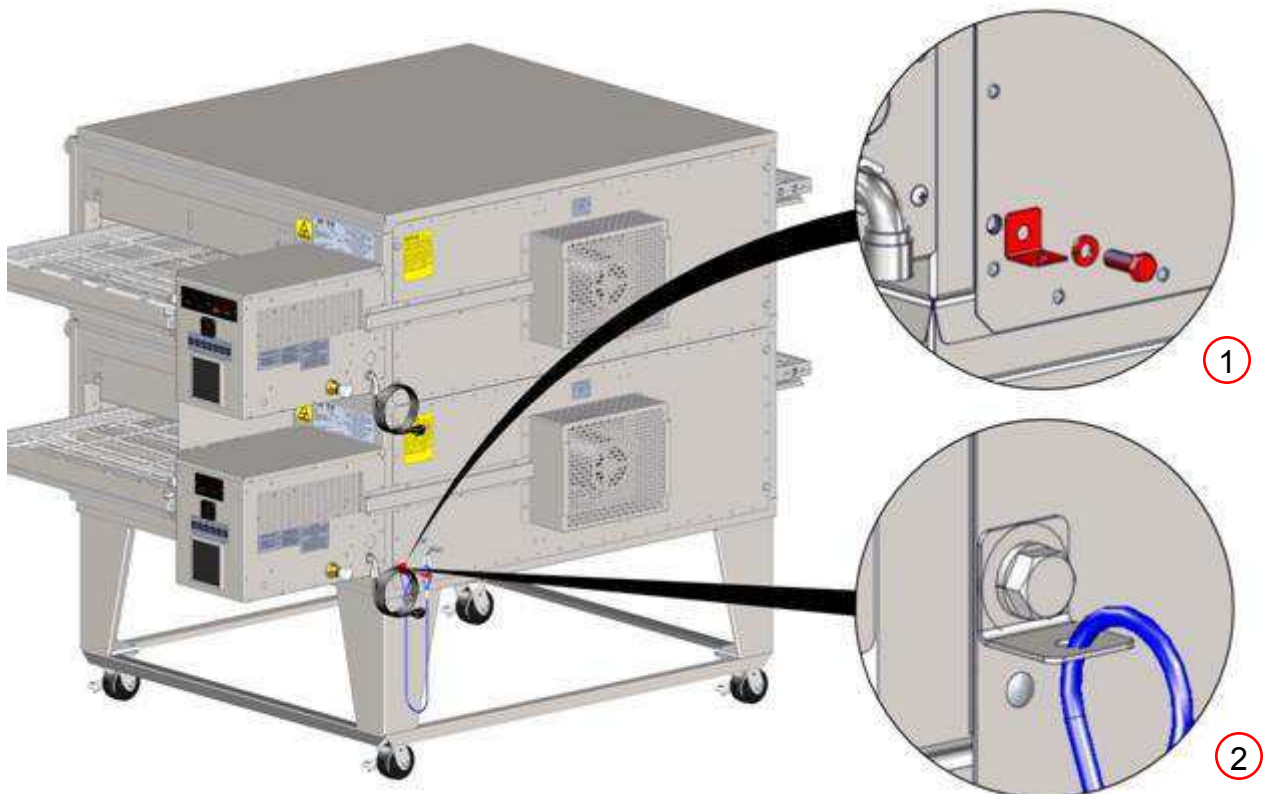

The requirement for fire suppression systems vary by location and the authority having jurisdiction. If you are required to install fire suppression on your oven, a pre-assembled piping kit is available that utilizes pre-existing holes that simplify installation and future service.



This design has been tested and approved to successfully comply with fire suppression codes. It uses only two (2) nozzles per bake chamber, and allows crumb trays, chain guards, and all other accessories to be easily removed. The kit does not interfere with any operations or maintenance.

A flexible hose that connects the oven to the rest of the fire suppression system is also available. This allows easy movement of the oven(s) for cleaning and maintenance.



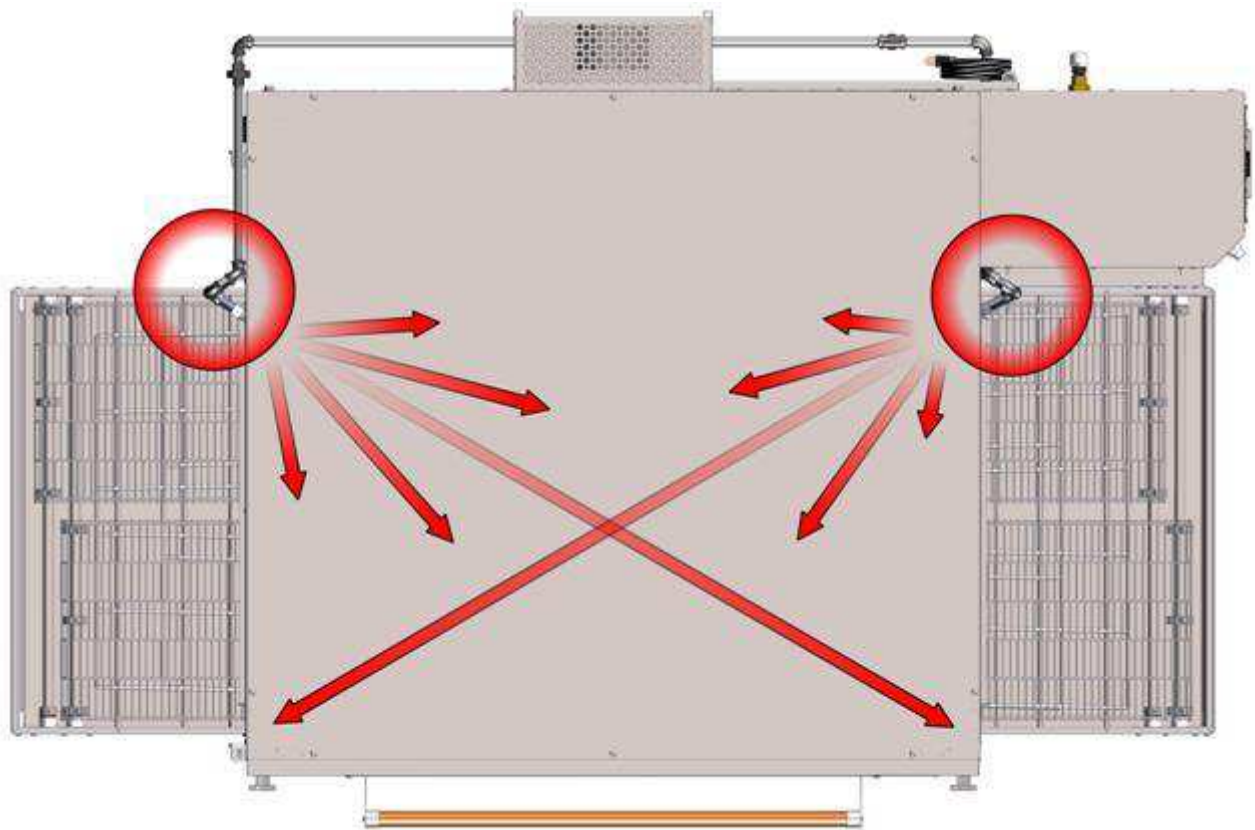
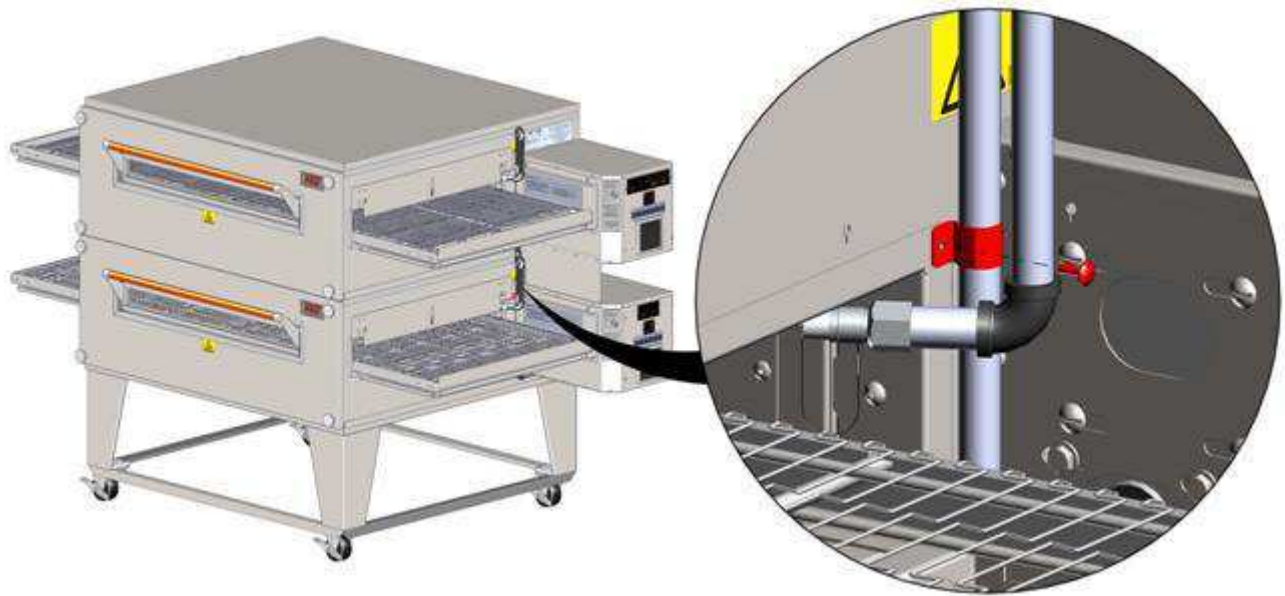

Ventilation Requirements

A powered ventilation hood is required to remove heat and vapors. Some provision must be made to replenish the amount of air that is extracted from the building. The hood and HVAC installation must meet local building and mechanical codes. Requirements vary throughout the country depending upon location. Proper ventilation is the oven owner's responsibility. The AVI Hood system is designed to meet all requirements for XLT ovens and it is our recommendation that this system be used.

Ventilation Guidelines

Obtain information from the authority having jurisdiction to determine the requirements for your installation. Your ventilation hood supplier and HVAC contractor should be contacted to provide guidance. An air balance test is highly recommended, performed by a licensed contractor. A properly engineered and installed ventilation hood and HVAC system will expedite approval, reduce all maintenance costs, and provide a more comfortable working environment. XLT also recommends that the operator switches for the ovens and the operator switch for the exhaust fan be interlocked so that the exhaust fan gets energized whenever the ovens are turned on. For more information, see the following links at xltovens.com:

[Kitchen Ventilation Design Guide 1](#)

[Kitchen Ventilation Design Guide 2](#)

[Kitchen Ventilation Design Guide 3](#)

[Kitchen Ventilation Design Guide 4](#)

Ventilation Performance Test

After the oven and ventilation hood have been installed and are operating, a smoke candle can be used to “see” if the heat and vapors are being completely extracted. The test procedure is outlined below:

- The oven must be operating at 450°-500°F / 232°-260°C.
- The conveyor must be turned off.
- The ventilation hood exhaust fan must be turned on.
- Put a smoke candle in a pan on the conveyor belt at the center of the oven.
- Observe the smoke pattern coming out of the oven.
- Repeat the smoke candle test for each oven, as well as when all ovens are operating.

The ventilation hood must capture all of the smoke from the oven.

After the exhaust fan has been adjusted to completely capture and contain the heat, there needs to be a corresponding amount of make up air (MUA) introduced into the building to offset the amount of air volume being removed. An air balance test can determine the proper amount of make-up air flow rates.

All ovens are tested at the factory for functional operation. Operation is verified and adjustments are made to ensure proper function. However, field conditions are sometimes different than factory conditions. It is necessary to have an authorized service technician verify operation and make field adjustments if needed.

The Oven Initial Start-Up Checklist, found at the end of this manual, must be completed (both sides) at time of installation, signed by the Customer and returned to XLT Ovens and the Authorized Distributor to initiate Warranty Policy.

If the Start-Up Checklist is not filled out completely and returned to XLT Ovens, then the Warranty will not be honored.



CAUTION

This oven is not capable of being safely placed in operation in the event of a power failure. No attempt should be made to operate this oven during power failure.

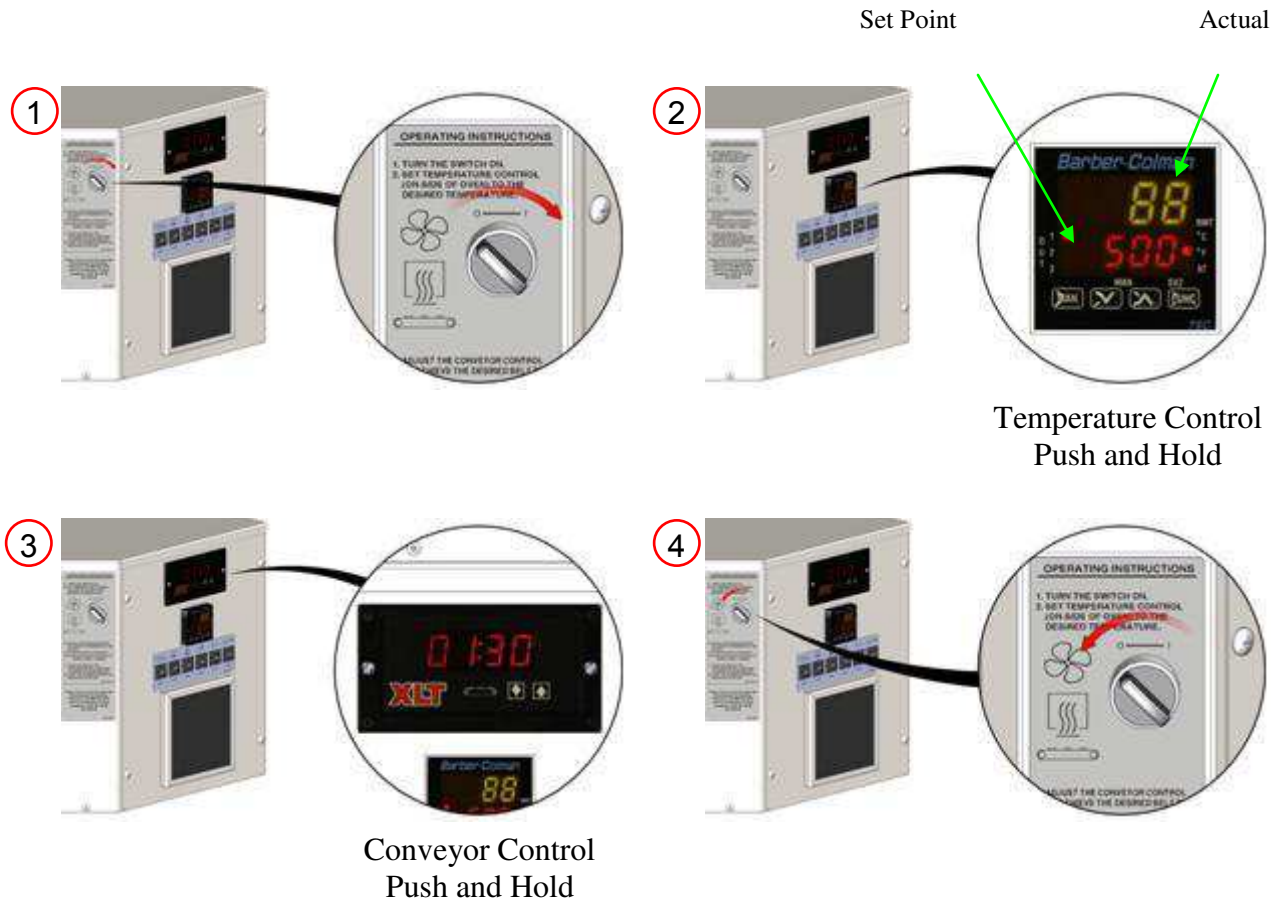

Conveyor Belt Times (Min:Sec)		
Oven Models	MINIMUM	MAXIMUM
All	1:30	17:00

Oven Operating Temperature Range		
Oven Models	MINIMUM	MAXIMUM
All	400° F	590° F
	205° C	310° C

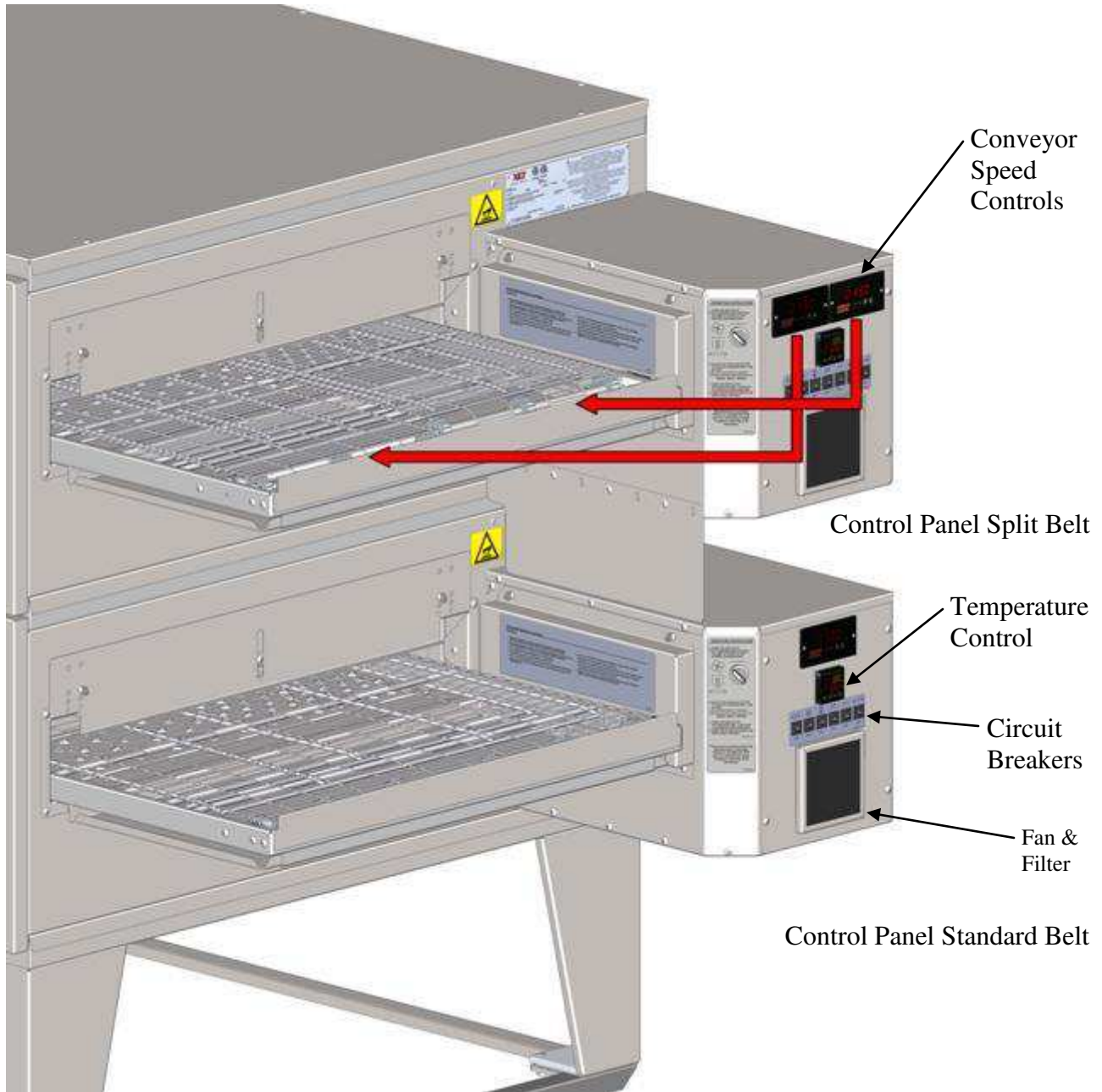

Your XLT oven is constructed of stainless steel. Most commercial cleaning agents may be used safely on all stainless steel surfaces. Check application restrictions on product label prior to usage. Observe recommended precautionary and safety measures as dictated by the product manufacturer. Do not use caustic cleaner on the conveyor bearings.

Do not use abrasive cleaners or abrasive pads as they can scratch stainless steel surfaces. Areas with heavy buildup should be sprayed and allowed to soak for up to 5 minutes prior to wiping clean. Always wipe with the “grain” of the surface to maintain appearance.

The most critical item to be cleaned is the filter on the fan. The filter is held in place by the stainless steel fan guard/filter mount & can be washed several times. Regular cleaning of the filter is important to maintain air circulation within the control box. Depending upon store conditions, this filter should be cleaned weekly or as it gets clogged with dust. Please contact XLT Ovens for replacement parts.



WARNING

Oven must be cool and the electric cord unplugged before any cleaning or maintenance is done.



CAUTION

If the oven is to be removed from its installed location for cleaning or servicing, the following procedure is to be followed:

1. Shut off main manual gas valve.
2. Unplug electric cord.
3. Unplug gas line.
4. Unlock casters.
5. Disconnect restraint.
6. When servicing or cleaning is complete, move oven to original location.
7. Connect restraint.
8. Lock casters.
9. Plug in electric cord.
10. Plug in gas line.
11. Turn manual gas valve on.
12. Follow normal lighting instructions.

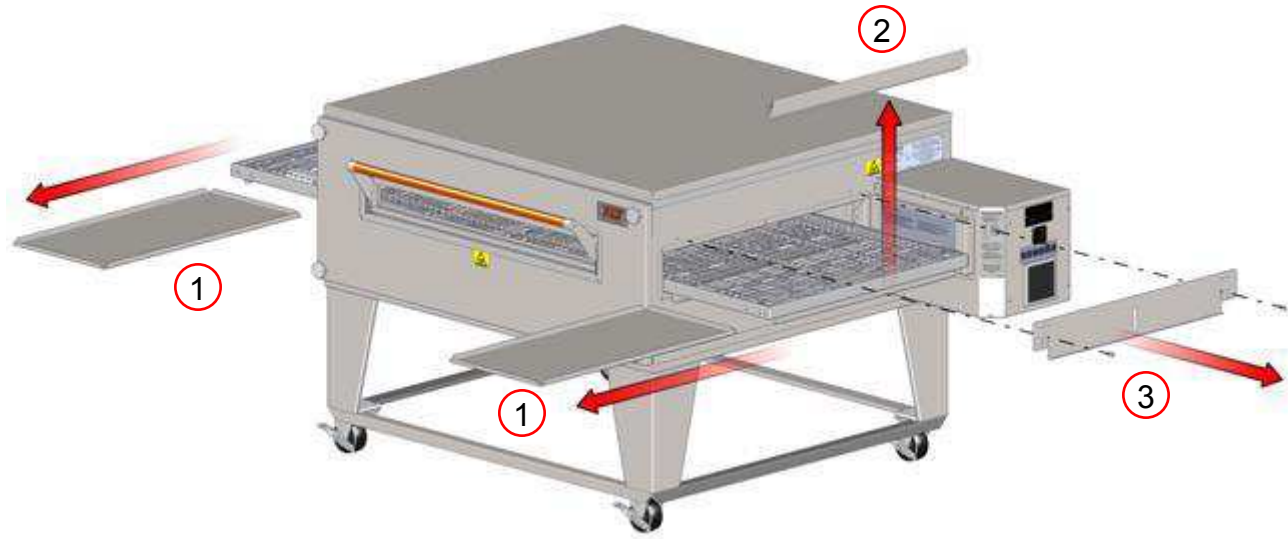

Opening the Sandwich Door will provide a grip location for removing the Front Panel.

TIP



CAUTION

Front Panels can weigh up to 75 lbs. [34 kg]. Use caution when lifting.

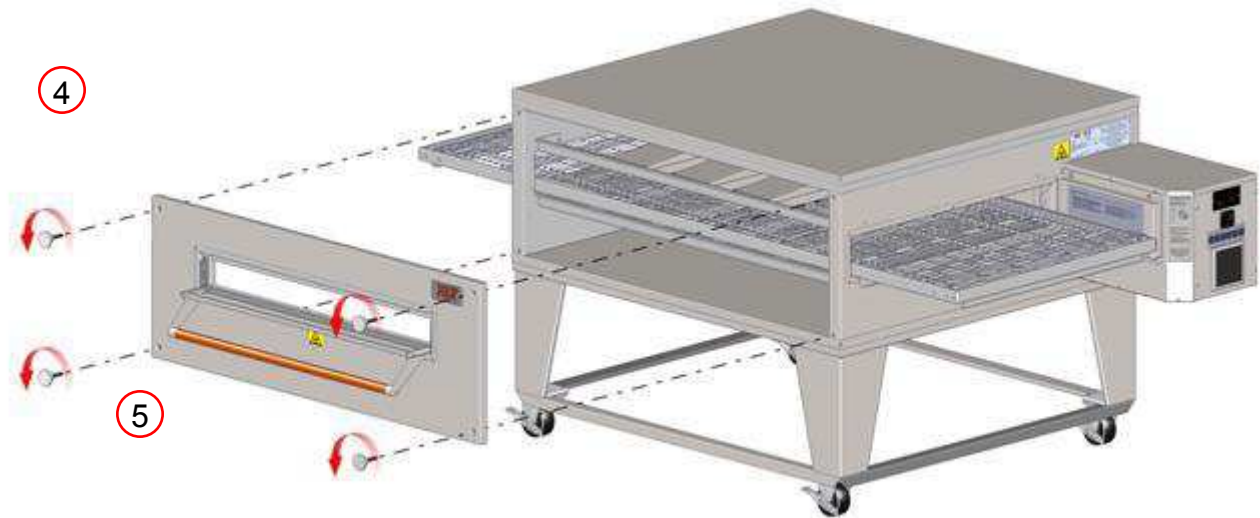

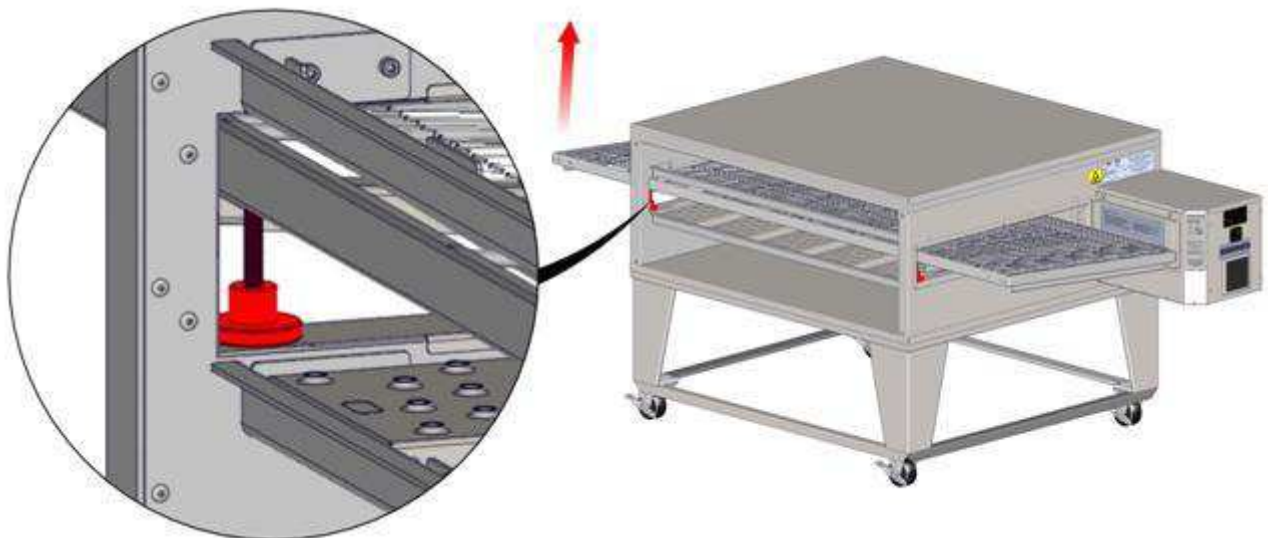
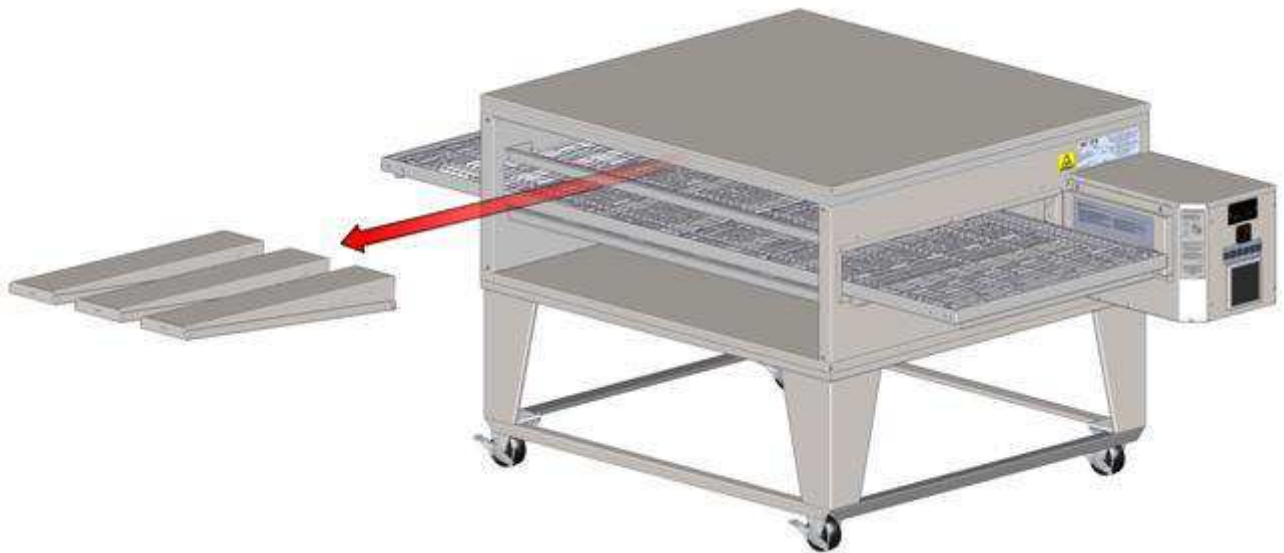
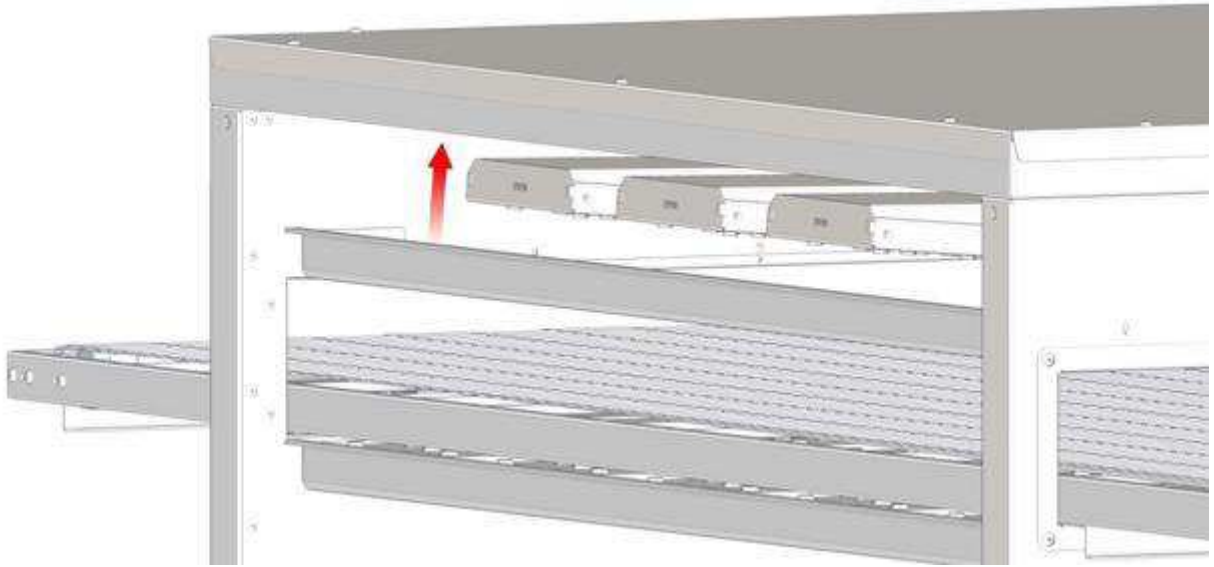

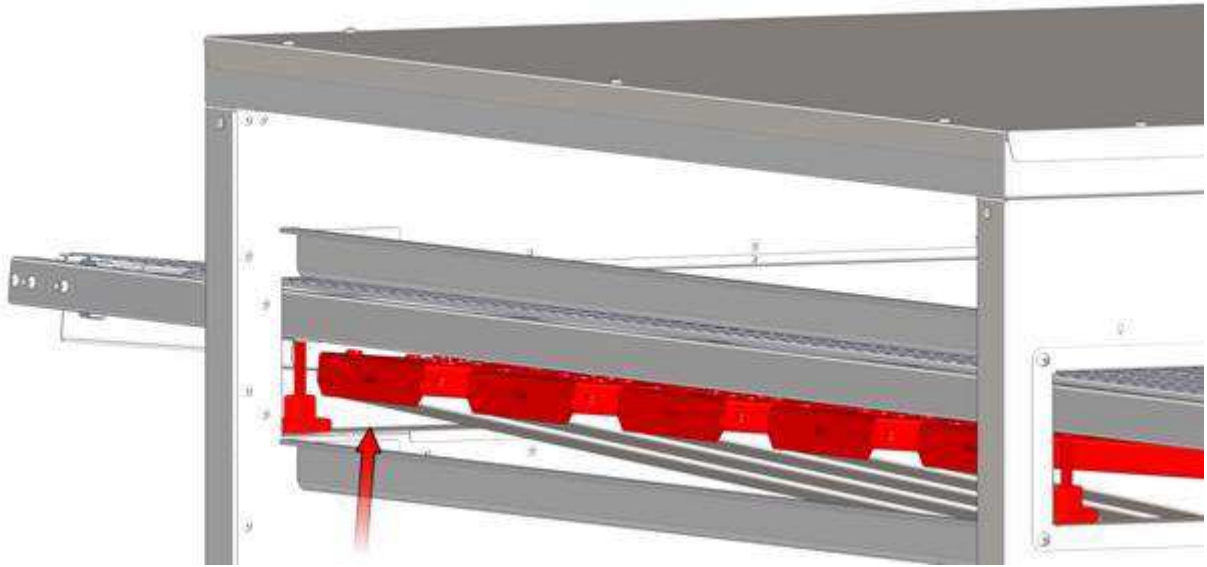

CAUTION

DO NOT spray liquid cleaning agents in the slots and holes in the following locations:

- Rear of Control Box
- Underneath Control Box
- Main Fan Motor Cover

As with any appliance, periodic maintenance is required. Many factors affect this schedule such as product mix and hours of usage. An example schedule is included.

Oven Maintenance Schedule					
	Daily	Weekly	Monthly	Semi-Annual	
Cleaning					
Empty Crumb Trays	<input type="checkbox"/>				
Wipe down Front, Sides, & Top	<input type="checkbox"/>				
Wipe down Control Box & Control Panel	<input type="checkbox"/>				
Clean or Replace Fan Filters	<input type="checkbox"/>				
Remove large debris from Conveyor		<input type="checkbox"/>			
Wipe down Motor Cover		<input type="checkbox"/>			
Clean Sandwich Window		<input type="checkbox"/>			
Remove debris from Finger Outers			<input type="checkbox"/>		
Remove debris from inside Bake Chamber			<input type="checkbox"/>		
Remove debris from Main Fan Motor			<input type="checkbox"/>		
Clean Finger Outers				<input type="checkbox"/>	
Clean inside Bake Chamber				<input type="checkbox"/>	
Clean Conveyor Assembly				<input type="checkbox"/>	
Inspection					
Check Fan Filters for dirt	<input type="checkbox"/>				
Check Conveyor Wire Belt for Stretch		<input type="checkbox"/>			
Check Conveyor Drive Roller Chain for Stretch			<input type="checkbox"/>		
Adjust					
Conveyor Wire Belt			<input type="checkbox"/>		
Lubricate					
Conveyor Drive Roller Chain				<input type="checkbox"/>	
Replace					
Fan Filters				<input type="checkbox"/>	

Contact a factory representative or a local service company to perform all other maintenance and repairs.



WARNING

Oven must be cool and the electric cord unplugged before any cleaning or maintenance is done.

Contact a factory representative or a local service company to perform all other maintenance & repairs.

Proper Cooking

Experimentation is about the only way to determine proper time and temperature settings. While a pizza may look perfectly cooked on the outside, the inside may be undercooked. A thermometer is necessary to determine if food items are being properly cooked. Most health departments have rules and regulations that establish minimum temperatures for internal food temperatures. Most operators want to cook foods as fast as possible in order to serve more customers per hour. However, cooking foods slower is the only way to achieve a proper internal temperature. If your food products look acceptable on the outside, but have an internal temperature that is too low, then lowering the temperature and decreasing the belt speed (thereby increasing the cook time), will be necessary.

Several factors may affect the cooking performance and characteristics:

1. Oven temperature (generally affects color)
2. Conveyor speed (generally affects doneness)
3. Finger arrangement
4. Altitude
5. Pans versus screens
6. Dough thickness
7. Cheese type
8. Raw ingredient temperature (frozen?)
9. Quantity of toppings

XLT ovens can be configured to cook a wide variety of food items. This is accomplished by arranging the fingers to control the baking characteristics. Generally speaking, most cooking is a “bottom up” process. The hot air from the bottom row of fingers has to go through the conveyor (a distance of about 2” / 50.8mm), heat the pan or screen, and then actually cook raw dough. The hot air from the top, on the other hand, basically only has to melt cheese and re-heat precooked toppings. Consequently, most operators will use the oven with the fingers arranged so that a lot more air is directed to the bottom of the pizza than to the top. There are places for an equal number of fingers above and below the conveyor. Available are finger cover plates that have six rows of holes, four rows of holes, two rows of holes, and no holes (or blank cover plates). A typical finger arrangement might have most or even all fingers on the bottom “full open”, that is fingers with all six rows of holes, and only two or three fingers on top with four or six rows of holes. The top fingers can be arranged in a symmetrical pattern or can be shifted asymmetrically to either the entrance or exit end of the conveyor. We encourage you to experiment by trying different finger arrangements, temperatures and belt speeds. XLT Ovens can assist you with your oven/product configurations.

Mechanical Function

If your oven does not function properly, please verify the following conditions:

1. Verify that the power cord to the oven is connected and/or plugged in if equipped with a plug and receptacle.
2. Check to see that the circuit breakers in the building electrical service panel have not been tripped or turned off.
3. Check all circuit breakers on the oven control panel to ensure they have not been tripped.
4. Gas line size and pressure must be adequate to support total BTU requirements with all appliances in store turned *on*. Refer to the “Oven Gas Requirements” section of this manual.
5. Check the quick-disconnect on the gas hose to verify that it is fully and completely engaged.
6. Check the Manual gas valve to verify that it is turned on completely. The handle on the valve should be parallel with the gas piping when the valve is turned on, and the handle will be perpendicular with the gas piping when the valve is turned off. Also remember that anytime the gas hose has been disconnected it will take time to purge the air from the gas train.
7. Check to see that the oven is fully assembled. All of the fingers must be properly installed. Incorrect or incomplete finger placement can cause a “windy” condition that can cause the burner not to light.

If your oven still does not function properly, XLT has qualified customer service personnel that can provide assistance on any type of XLT oven problem you may experience. Customer Service is available 24/7/365 at 888-443-2751, or visit www.xltovens.com. An interactive troubleshooting guide is available on the website.

**WARNING**

Check all local codes prior to installation. Special requirements may be necessary depending upon building material construction. It is the installing contractor's responsibly to ensure that the structure the hood is to be hung from meets all codes and can carry the hood weight.

Purchaser's Responsibility

It is the responsibility of the purchaser:

- Thoroughly review the floor plans and specifications. The exact location of the oven must be determined before installing the hood.
- To unload, uncrate, assemble, and install the hood to it's intended location.
- To ensure that electric utilities are installed on site in accordance with local building codes and with the specifications in this manual.
- To see that electric utilities are connected properly by a qualified installer using the proper hardware.
- To ensure a qualified installer has performed an initial start-up procedure.
- Location should minimize long and twisted duct runs. Make efforts to have a straight clear path to the roof fan curb.
- All hood supporting structures must be strong enough to support the weight of the hood and shrouds. Refer to the Hood Dimensions & Weights page for weight.
- Maintain the proper clearances from combustible materials according to International Mechanical code (IMC), and National Fire Protection Agency (NFPA) 96, and local mechanical codes.

HOOD DESCRIPTION

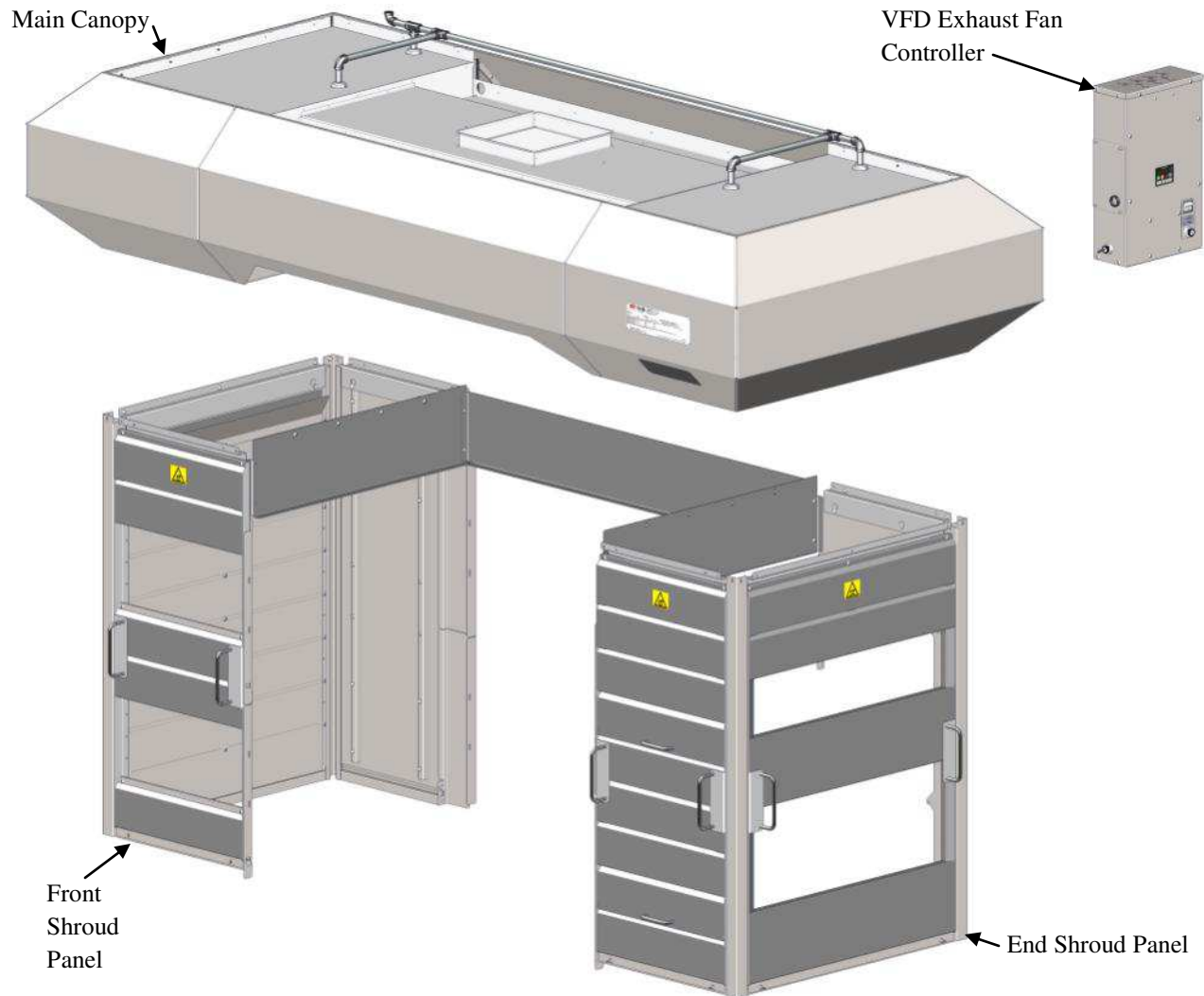

The AVI Hood System consists of three (3) major parts; the Main Canopy, the Shrouds, and the Variable Frequency Drive (VFD) exhaust fan controller.

The Main Canopy serves to collect and transmit heat to the exhaust fan. It houses filters, lights, and switches. The switches control both the hood and ovens. The main canopy size is dependent upon oven size.

The Shrouds assist the efficiency of the main canopy by entrapping heat. They are configurable for either side or end loading or unloading, and are easily removable for cleaning and maintenance.

The VFD converts input power to variable frequency three-phase output power to control the speed of the exhaust fan. All electric utilities for the hood and exhaust fan connect through the electrical box located on the rear of main canopy. The operator switches are located on the control panel on the front of main canopy, and interlock the function of the hood and oven(s). There are optional relays that provide interlocks for equipment such as, fire suppression, HVAC dampers, and/or dedicated MUA units.

All AVI hoods are available pre-piped for fire suppression, allowing for simple, in-field installations.

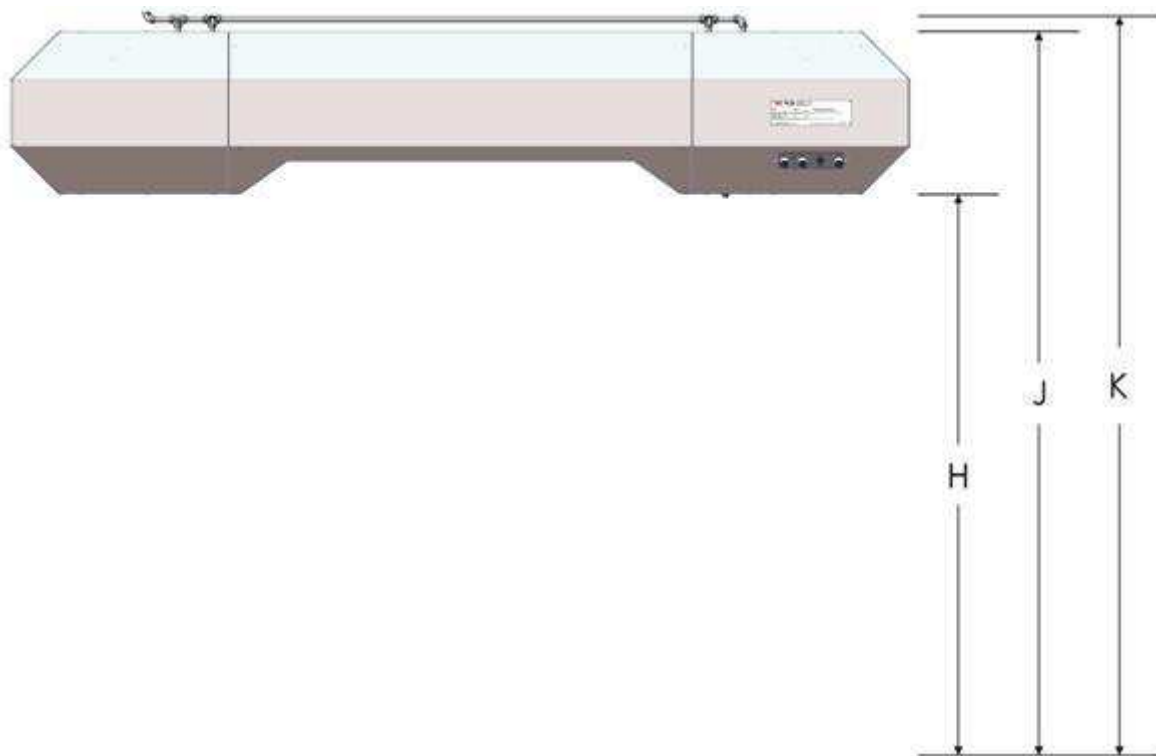
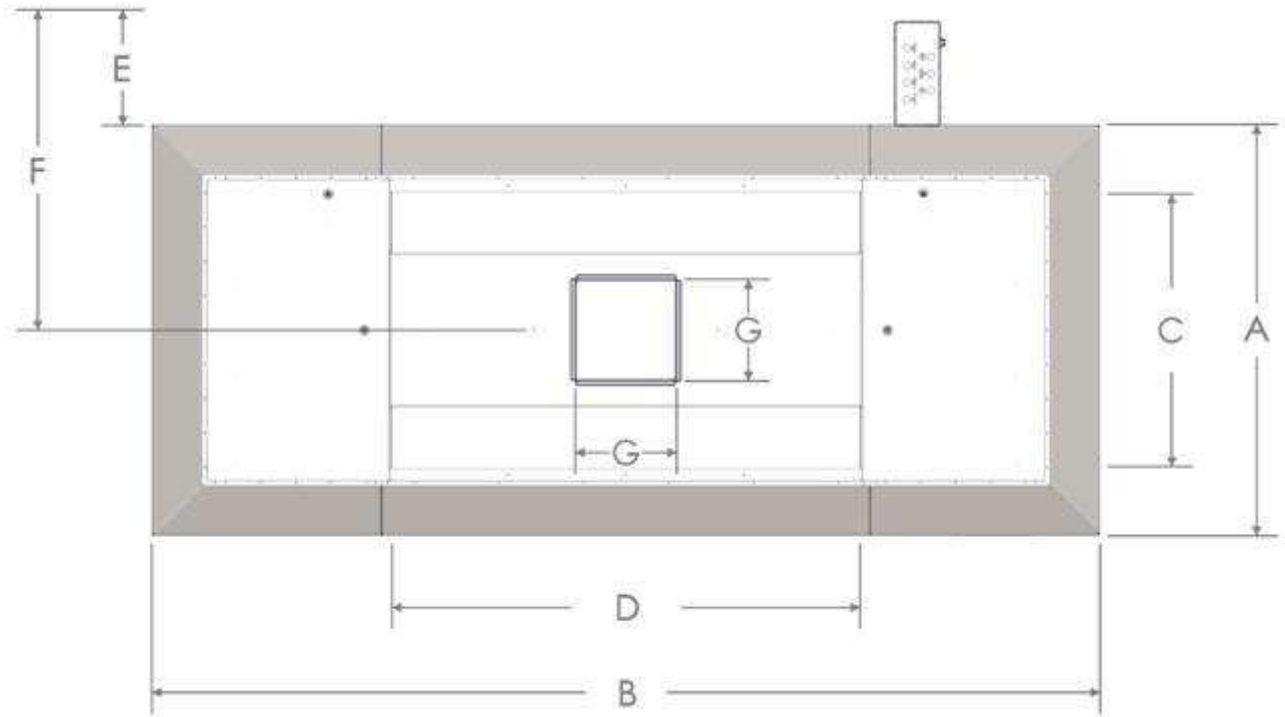

Oven Model	Hood Dimensions										Hood Weights		
	A	B	C	D	E	F	G	H	J	K	Single	Double	Triple
1832	34 3/8 [873]	88 5/8 [2251]	18 [457]	32 [813]	13 1/2 [343]	30 5/8 [778]	12 [305]	69 5/8 [1768]	89 7/8 [2283]	91 3/4 [2330]	540 [245]	500 [227]	525 [238]
2440	40 3/8 [1026]	96 5/8 [2454]	24 [610]	40 [1016]		33 5/8 [854]					620 [281]	570 [259]	595 [270]
3240	48 3/8 [1229]	96 5/8 [2454]	32 [813]	40 [1016]		37 5/8 [956]					680 [308]	630 [286]	655 [297]
3255	48 3/8 [1229]	111 5/8 [2835]	32 [813]	55 [1397]		37 5/8 [956]					740 [336]	670 [304]	695 [315]
3270	48 3/8 [1229]	126 5/8 [3216]	32 [813]	70 [1778]		37 5/8 [956]					780 [354]	705 [320]	720 [327]
3855	54 3/8 [1381]	111 5/8 [2835]	38 [965]	55 [1397]		40 5/8 [1032]					795 [361]	720 [327]	745 [338]
3870	54 3/8 [1381]	126 5/8 [3216]	38 [965]	70 [1778]		40 5/8 [1032]					825 [374]	750 [340]	770 [349]

NOTE: All dimensions in inches [millimeters], ± 1/4 [6], unless otherwise noted.
All weights in pounds [kilograms] unless otherwise noted.

Inputs into VFD Box

AVI Hood Electric Utility Specifications			
	# of Circuits	Rating	Purpose
Australian	1	230 VAC, 1 Phase, 50 Hz, 3 Amp	VFD Controller
	1	230 VAC, 1 Phase, 50 Hz, 1 Amp	Lights
Standard	1	208/240 VAC, 3 Phase, 60 Hz, 3 Amp	VFD Controller
	1	120 VAC, 1 Phase, 60 Hz, 1 Amp	Lights
World	1	230 VAC, 1 Phase, 50 Hz, 3 Amp	VFD Controller
	1	230 VAC, 1 Phase, 50 Hz, 1 Amp	Lights

Outputs from VFD Box

The AVI Hood system provides:

- Three (3) switching outputs for HVAC dampers and dedicated units
- One (1) 230 VAC, 10 Amp, variable frequency, three phase power output for the ventilation exhaust fan.
- Three (3) receptacles for ovens.
- One (1) 120 VAC fire alarm signal for Standard hoods, or one (1) 24 VAC fire alarm signal for World Hoods



VFD Control Box - Standard

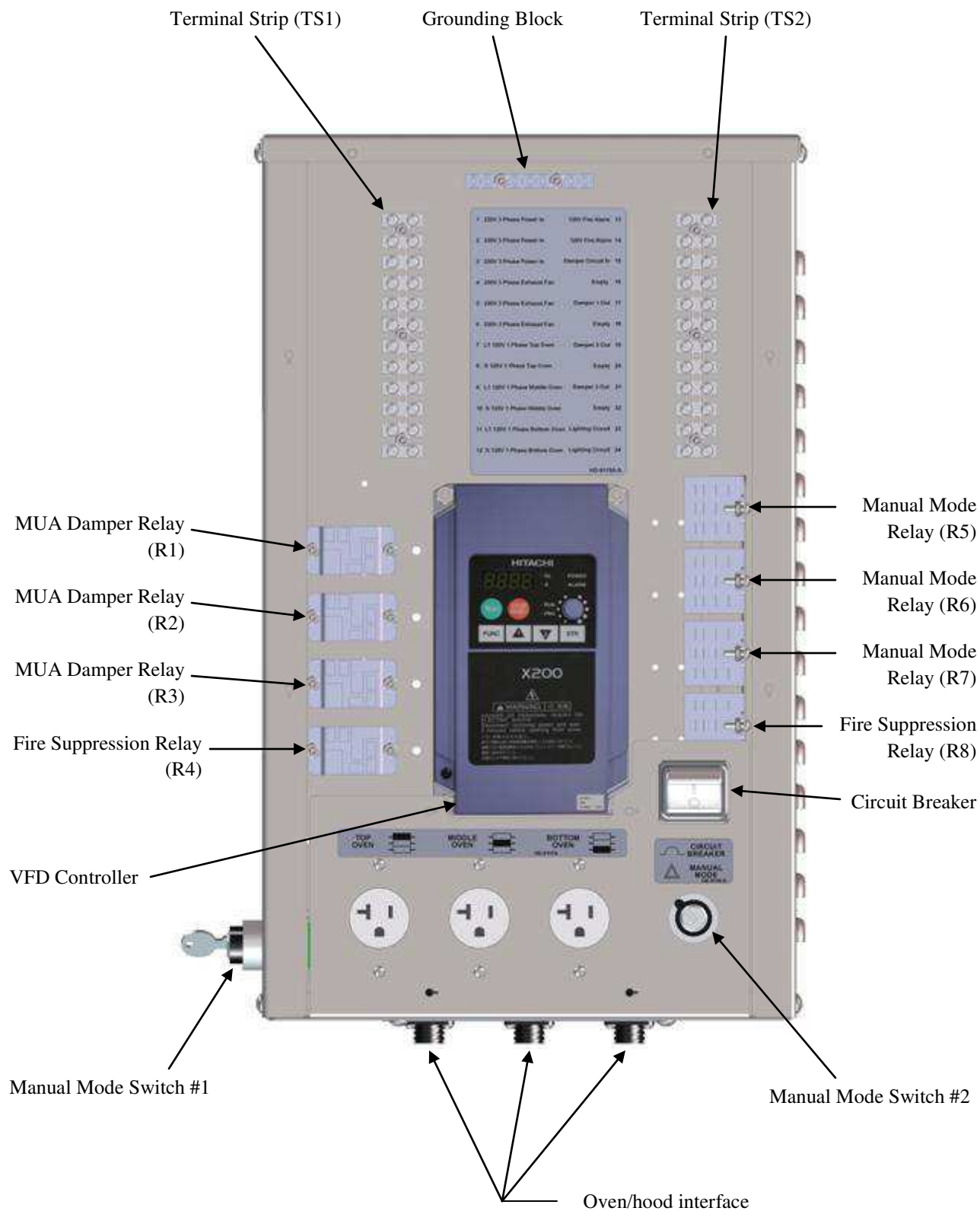

VFD Control Box (Cover removed)

Input Power to VFD Controller - Standard Voltage & Frequency



Input Power to Lights with VFD- Standard Voltage & Frequency

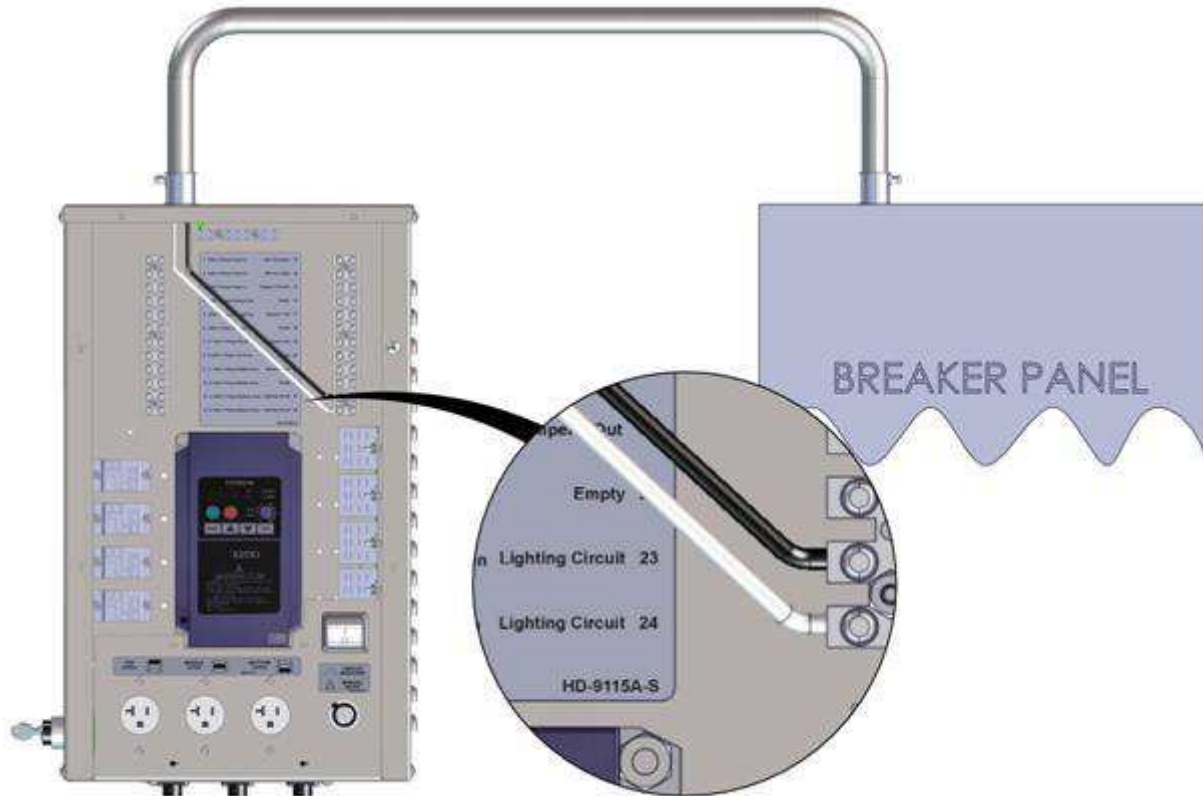

Power from VFD to Exhaust Fan - Standard Voltage & Frequency

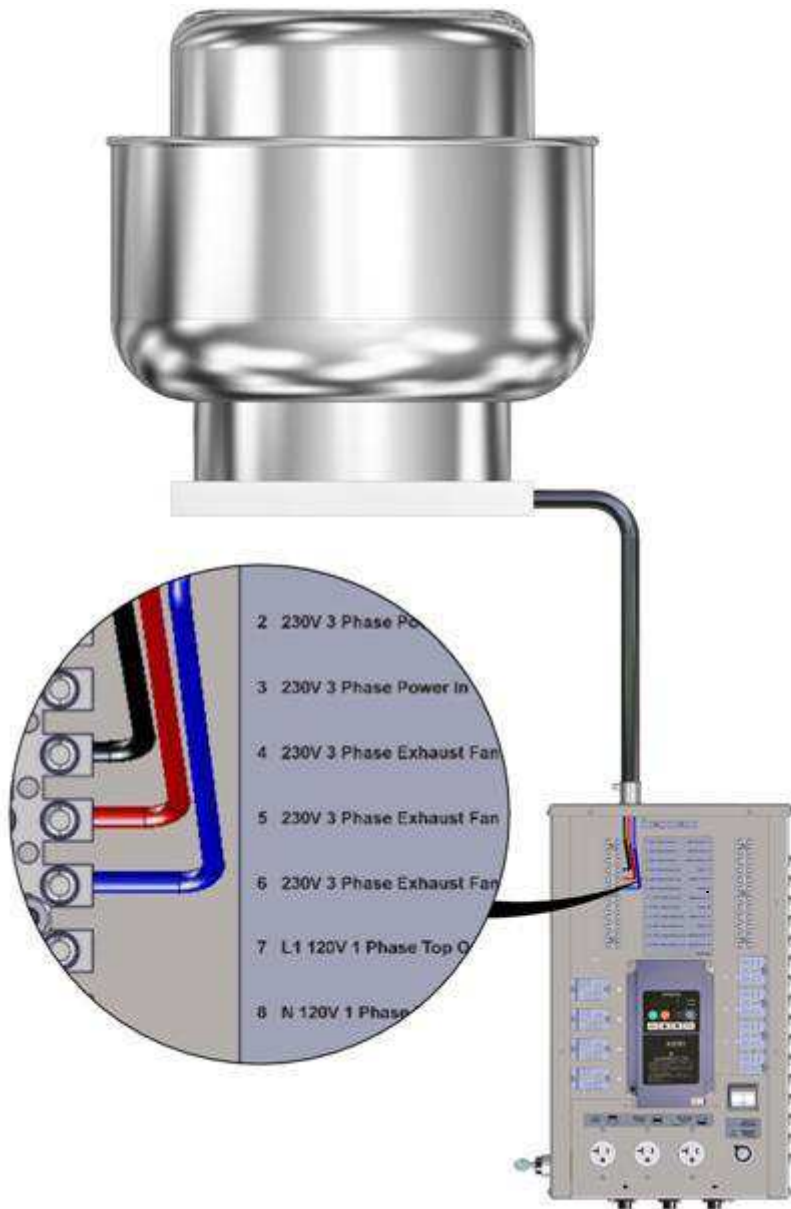

Fire Alarm Relay - Standard Voltage & Frequency

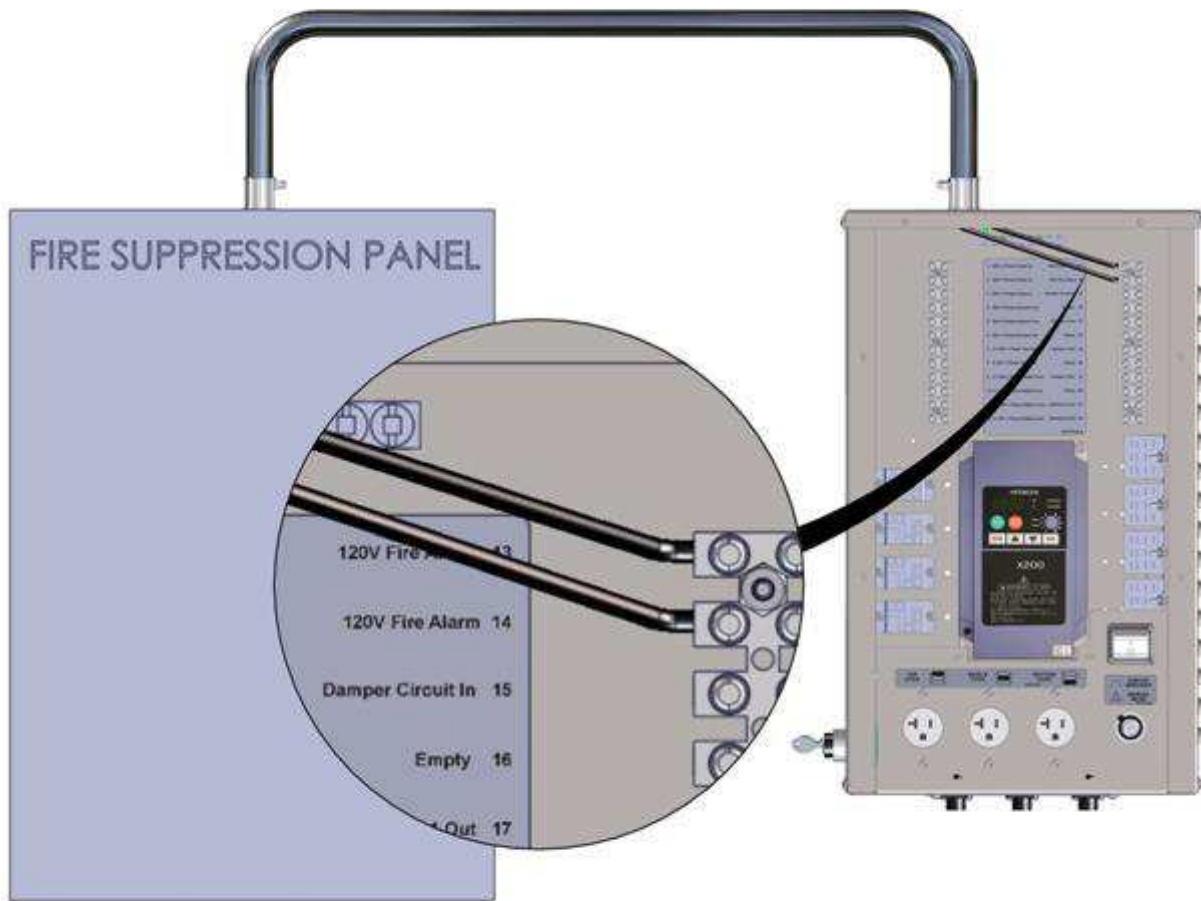

MUA Damper Relays - Single Output - Standard Voltage & Frequency

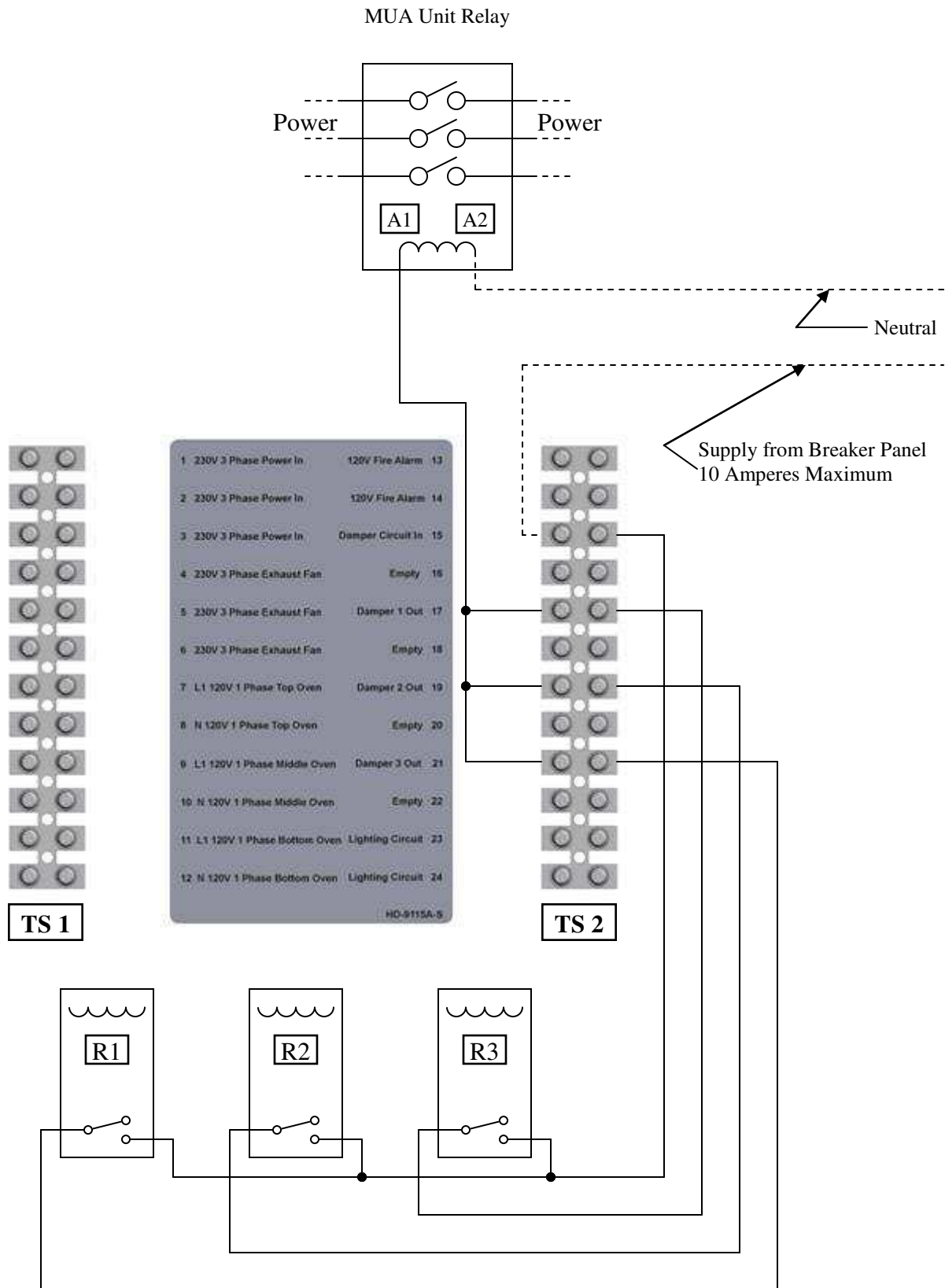

Some wiring removed for clarity. See schematic for details.

MUA Damper Relays - Multiple Output - Standard Voltage & Frequency

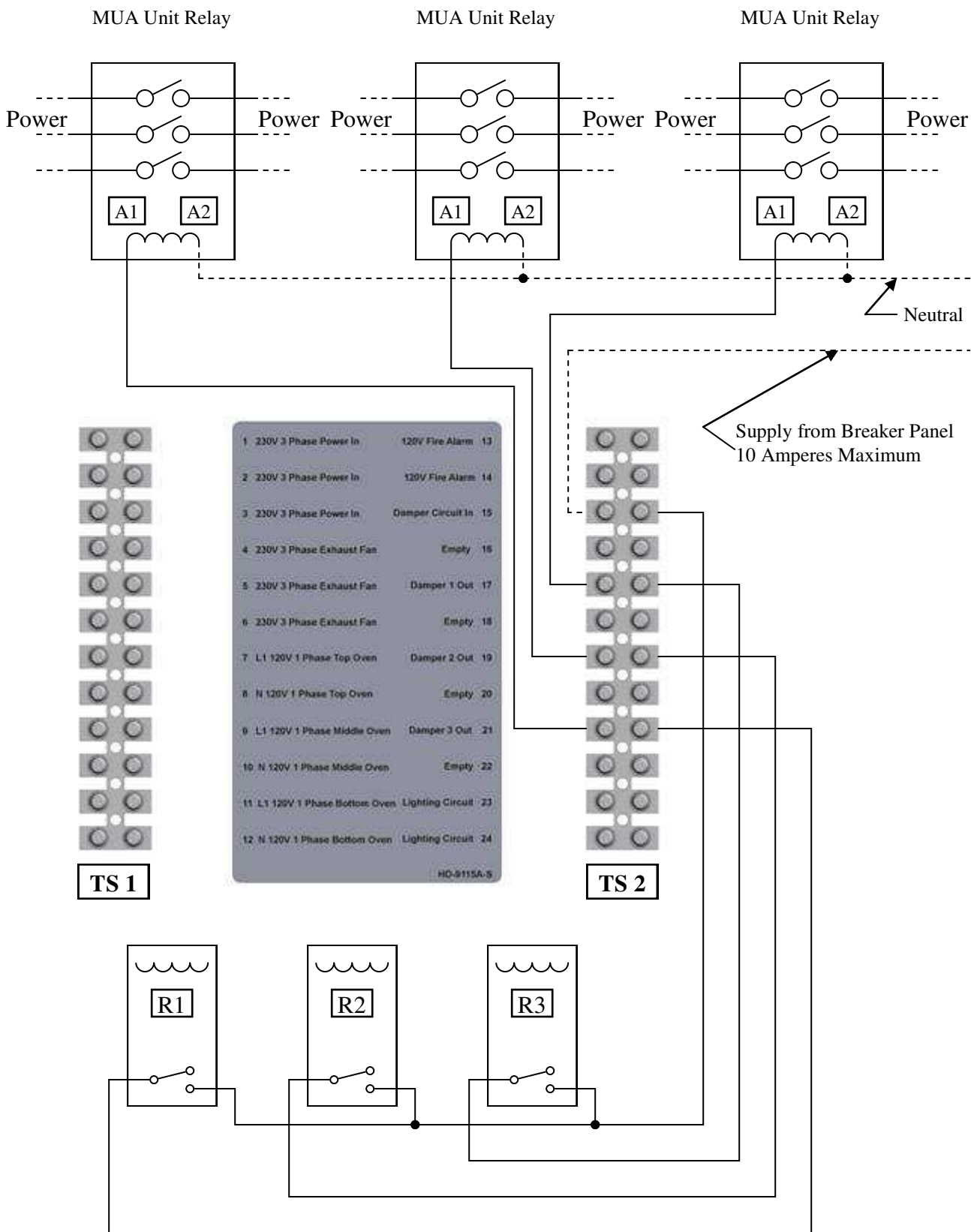

Some wiring removed for clarity. See schematic for details.

VFD Control Box - World

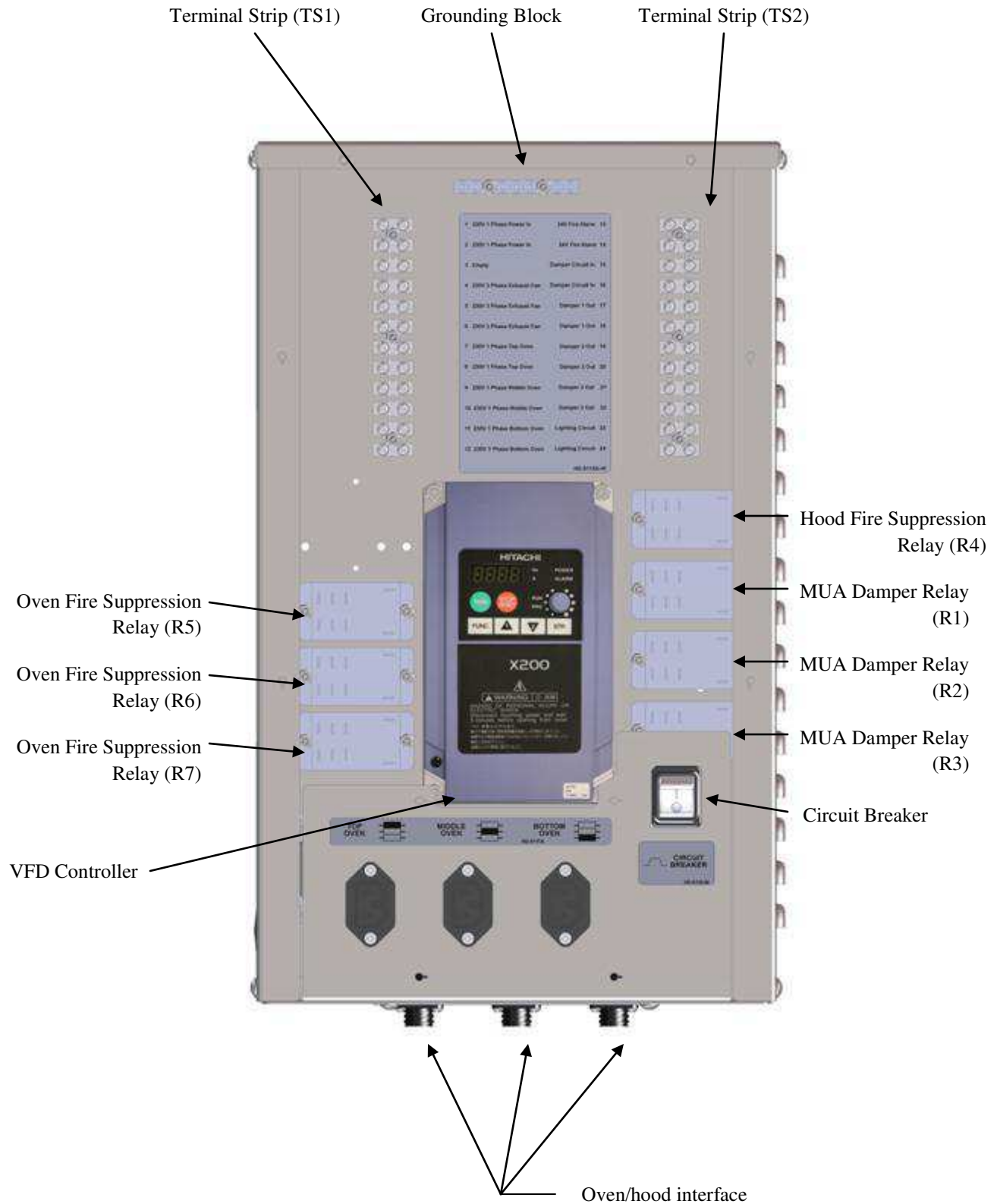

VFD Control Box (Cover removed)

Input Power to VFD Controller - World Voltage & Frequency

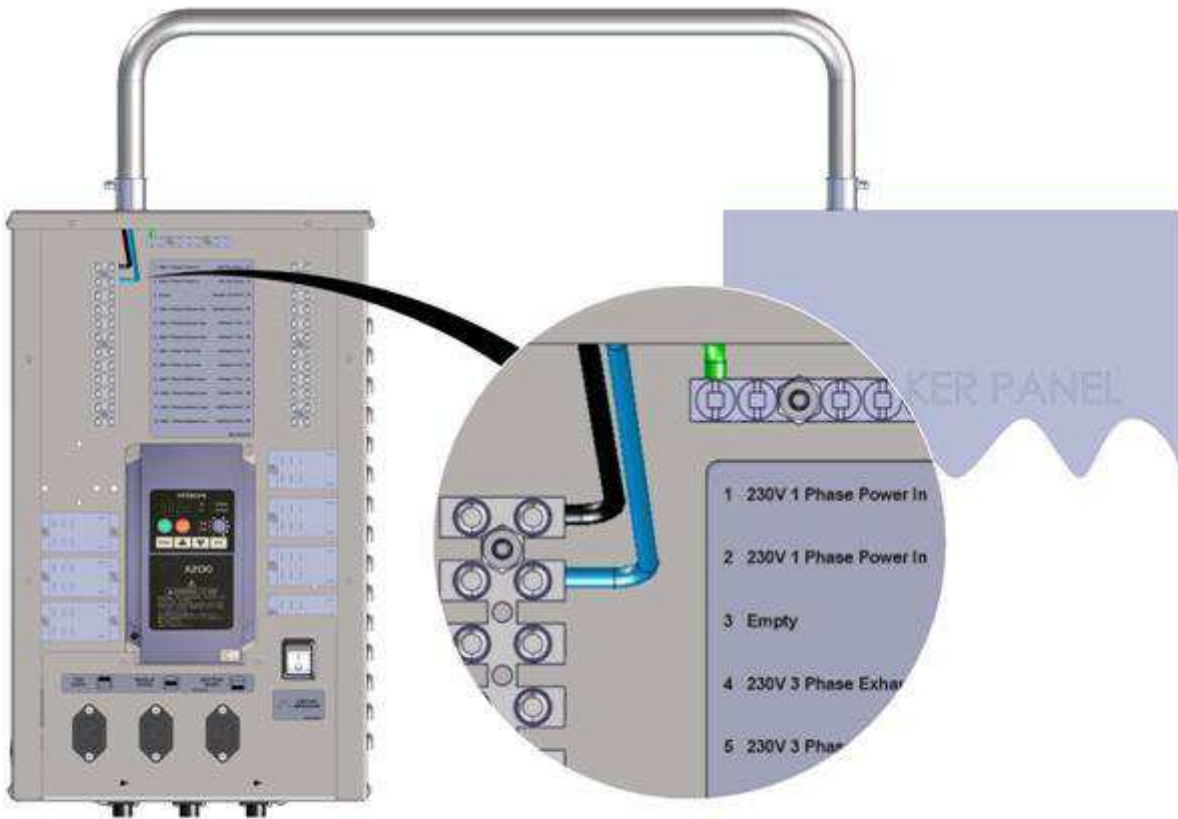

Output Power from VFD to Exhaust Fan - World

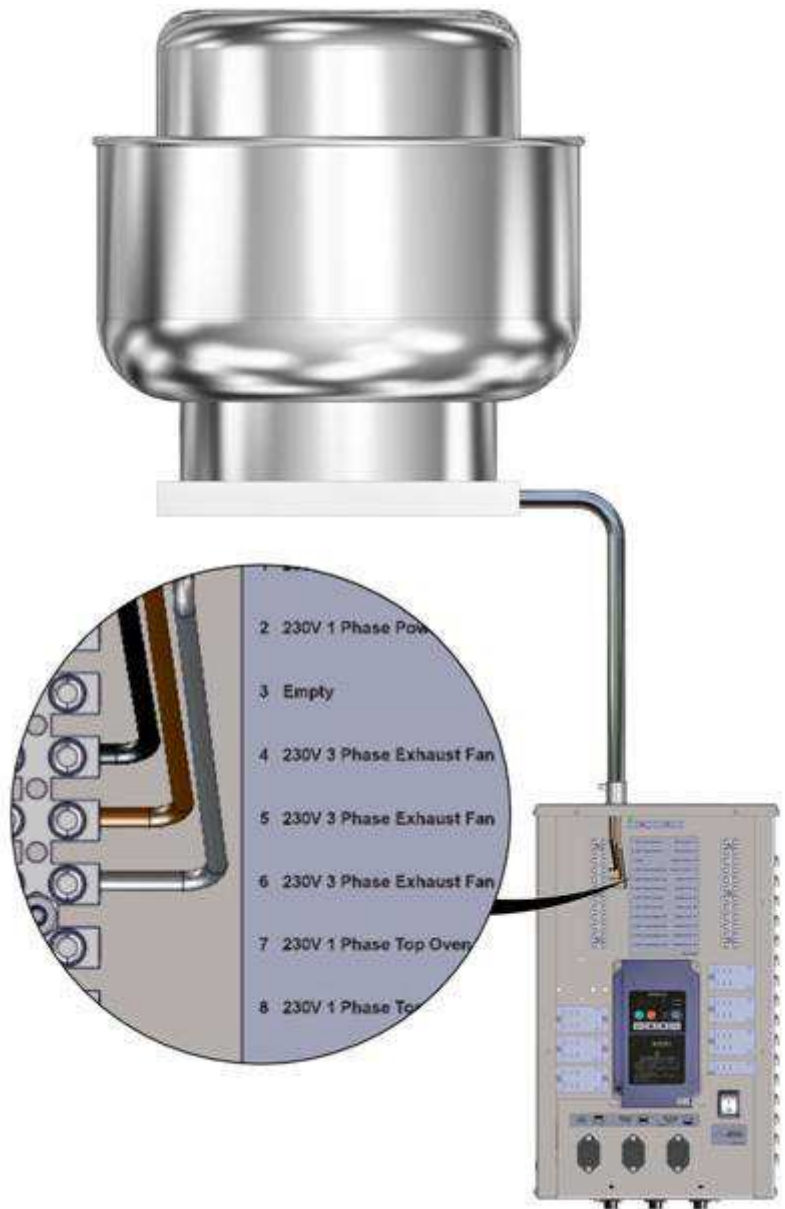

Fire Alarm Relay - World (optional)



MUA Damper Relays - Single Output - World Voltage & Frequency

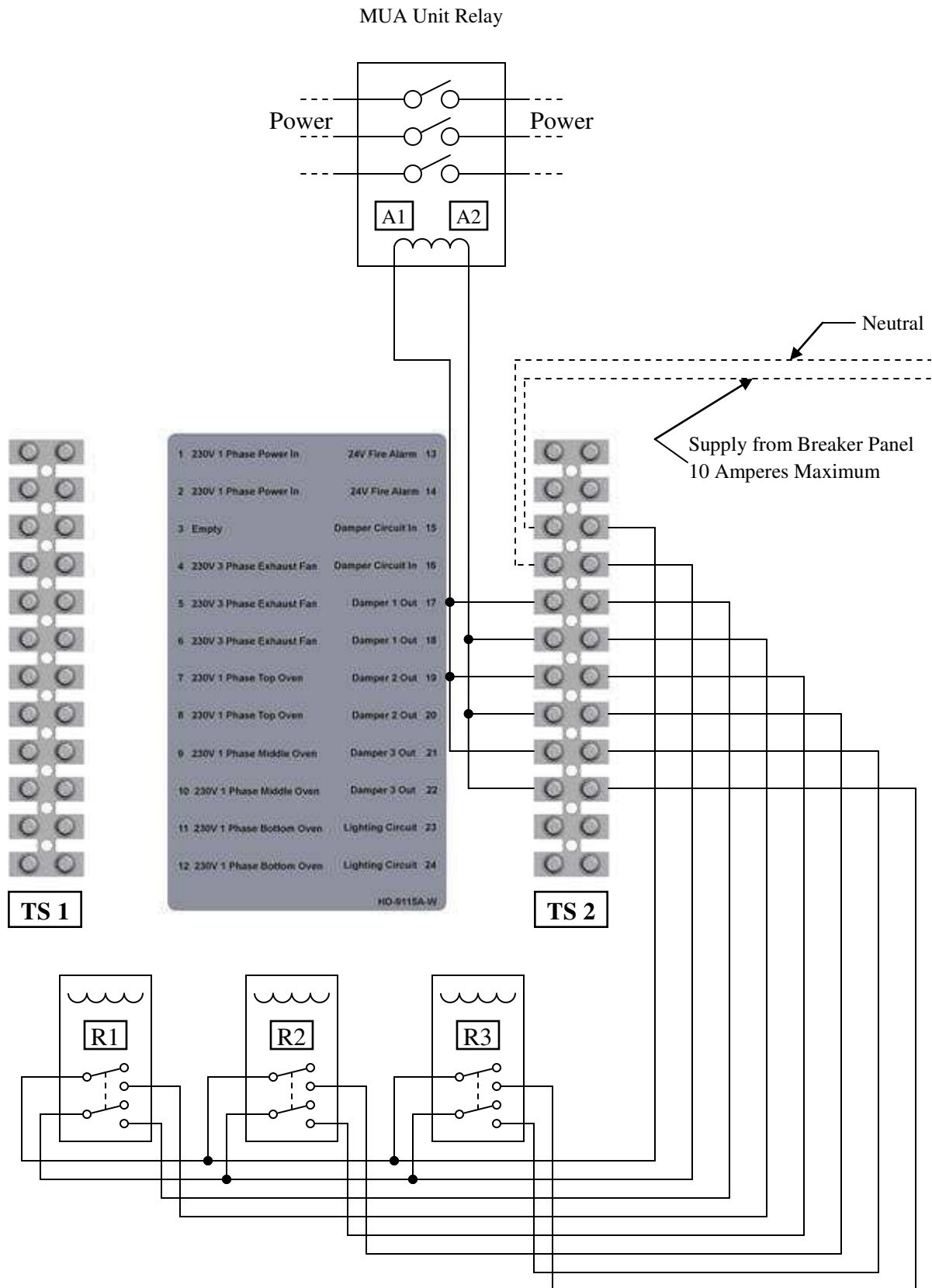

Some wiring removed for clarity. See schematic for details.

MUA Damper Relays - Multiple Output - World Voltage & Frequency

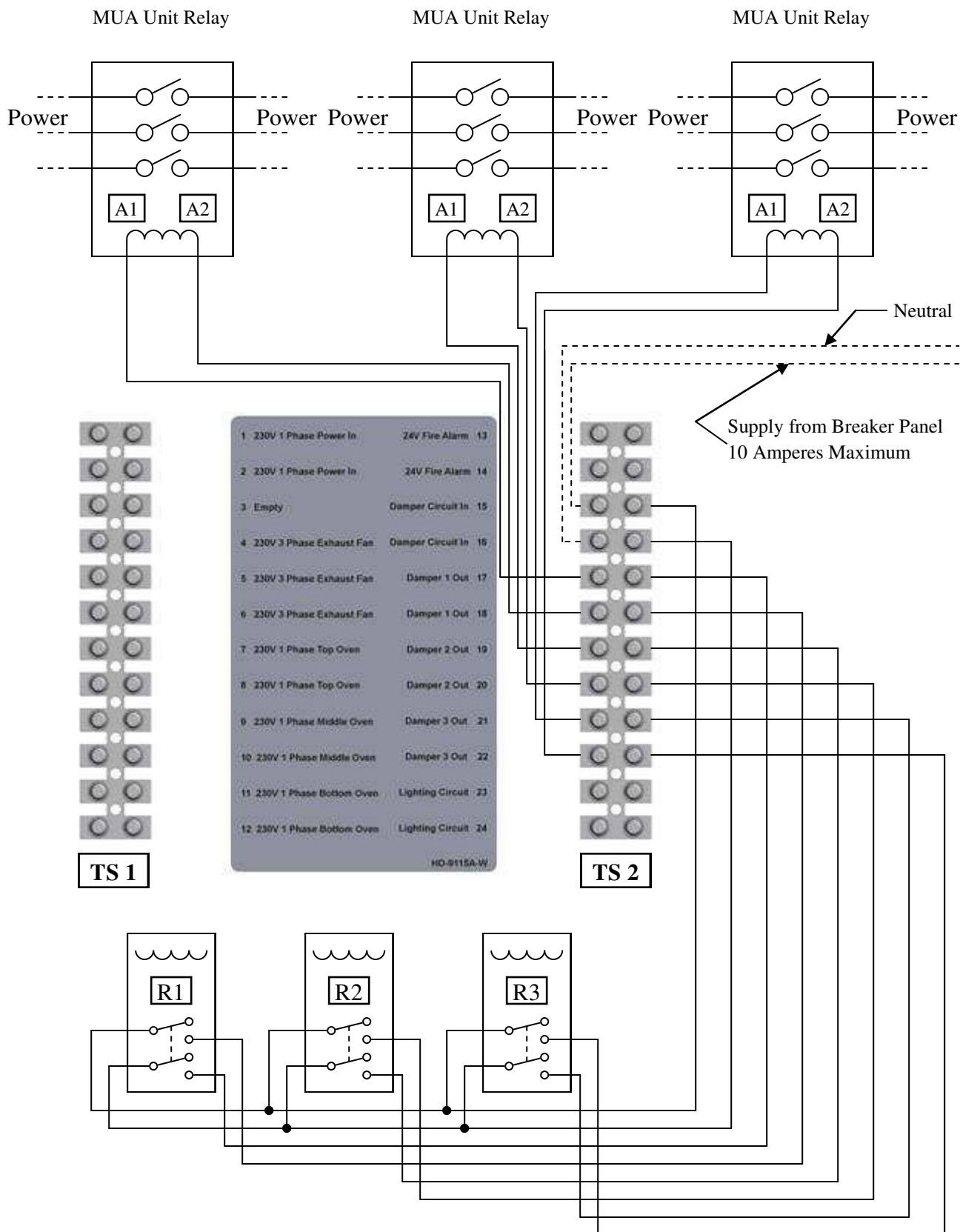

Some wiring removed for clarity. See schematic for details.

Input Power to Lights - Without VFD Controller

Terminal Strip (TS1)

Grounding Block



Non-VFD Control Box (Cover removed)

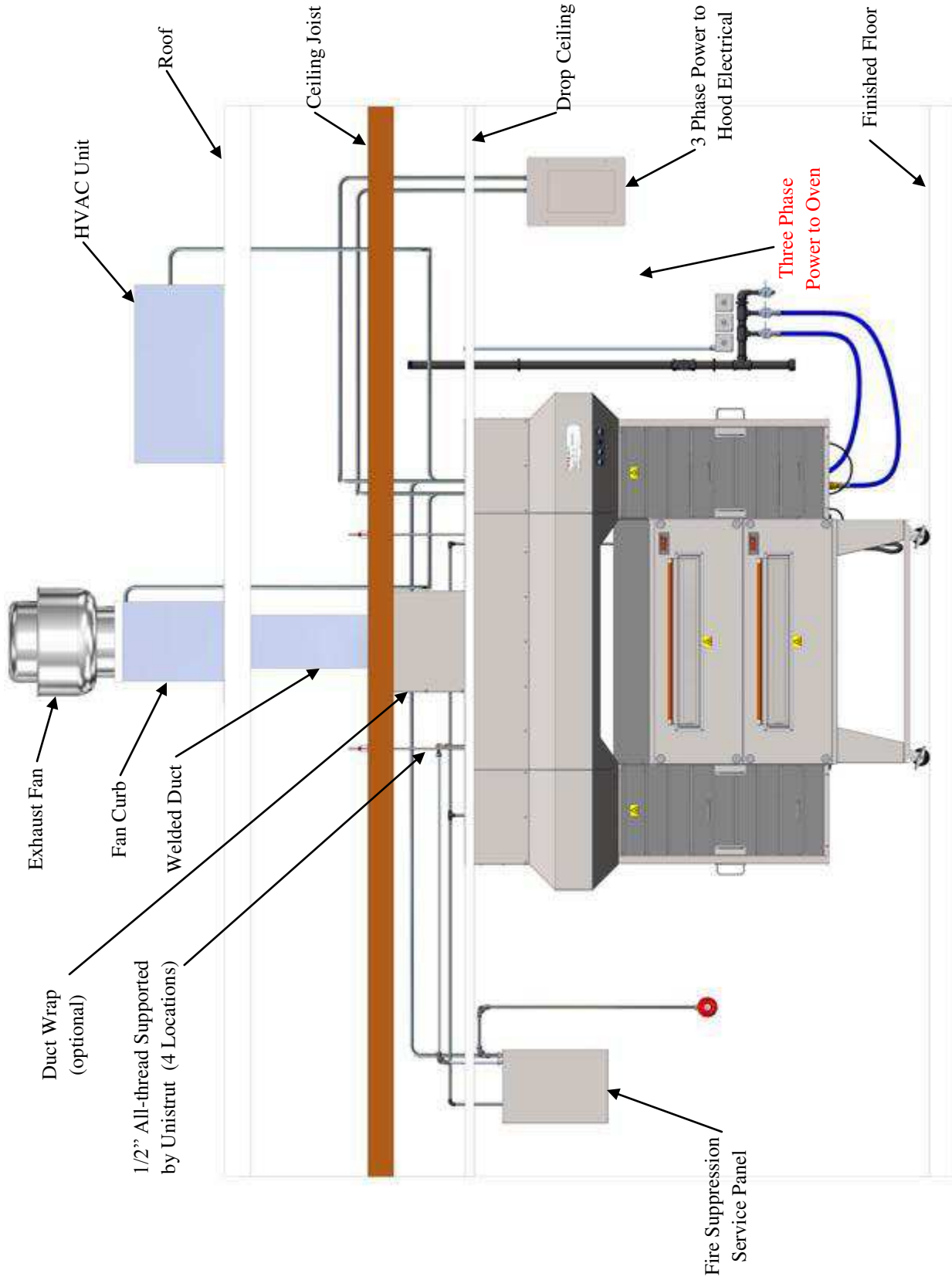

All structural members, electrical & fire suppression equipment shown for reference only.

Exhaust Flow Rates VOLUME (min. recommended)								
		Switches On			18xx	24xx	32xx	38xx
		Top	Middle	Bottom				
Single	X				500	500	500	500
					[14.16]	[14.16]	[14.16]	[14.16]
Double	X				500	500	500	500
					[14.16]	[14.16]	[14.16]	[14.16]
	X		X		506	644	828	966
					[14.33]	[18.24]	[23.45]	[27.35]
Triple	X				500	500	500	500
					[14.16]	[14.16]	[14.16]	[14.16]
	X	X			506	644	828	966
					[14.33]	[18.24]	[23.45]	[27.35]
	X		X		766	975	1254	1463
					[21.69]	[27.61]	[35.51]	[41.43]
	X	X	X		506	644	828	966
					[14.33]	[18.24]	[23.45]	[27.35]
X		X	X	766	975	1254	1463	
				[21.69]	[27.61]	[35.51]	[41.43]	
X	X	X	X	766	975	1254	1463	
				[21.69]	[27.61]	[35.51]	[41.43]	

NOTE: All values are CFM [M^3/Min] unless otherwise noted.

NOTE: Figures represent TOTAL VOLUME measured at the duct.

In accordance with mechanical codes, make up air must be supplied. For commercial kitchen make up air, the amount is determined by the exhaust hood flow rate requirements & all other exhaust flow rate requirements in the kitchen.

At a minimum, smoke candles must be used for a Capture & Containment (C&C) test. Refer to the Ventilation Requirements disclosed in the Oven section in this manual.

A Test & Balance (TAB) report is recommended after installation has been completed. Below are the minimum items to be included in this report:

- Total airflow on all A/C, Make-Up Air (MUA), & exhaust systems.
- Airflow on each supply & exhaust grille.
- Airflows on exhaust hoods compared to design specifications.

A final air balance report, with any corrections of issues found in the report, will help to insure that your building systems are functioning properly & efficiently.

[Refer to “Oven Ventilation Requirements & Guidelines”](#)

Exhaust Flow Rates VELOCITY (min. recommended)								
		Switches On			18xx	24xx	32xx	38xx
		Top	Middle	Bottom				
Single	X				187.5	187.5	93.75	93.75
					[57.15]	[57.15]	[28.58]	[28.58]
Double	X				187.5	187.5	93.75	93.75
					[57.15]	[57.15]	[28.58]	[28.58]
	X		X	X	189.75	241.5	155.25	181.125
					[57.84]	[73.61]	[47.32]	[55.21]
Triple	X				187.5	187.5	93.75	93.75
					[57.15]	[57.15]	[28.58]	[28.58]
	X	X			189.75	241.5	155.25	181.125
					[57.84]	[73.61]	[47.32]	[55.21]
	X		X	X	287.25	365.625	235.125	274.3125
					[87.55]	[111.44]	[71.67]	[83.61]
	X	X			189.75	241.5	155.25	181.125
					[57.84]	[73.61]	[47.32]	[55.21]
	X		X	X	287.25	365.625	235.125	274.3125
					[87.55]	[111.44]	[71.67]	[83.61]
X	X	X	X	287.25	365.625	235.125	274.3125	
				[87.55]	[111.44]	[71.67]	[83.61]	
X	X	X	X	287.25	365.625	235.125	274.3125	
				[87.55]	[111.44]	[71.67]	[83.61]	

NOTE: All values are FPM [M/Min] unless otherwise noted.

NOTE: Figures represent VELOCITY measured at the Grease Filter.

NOTE: Most building codes require 500 Feet per Minute velocity. Exhaust duct is 1 ft². Check with your local building official for requirements.

The VELOCITY readings above are obtained by holding an anemometer 3” away from the Grease Filter. Take several readings in different locations across the filters and average the results.

Prepare Ovens - Remove Lid Screws - Two (2) Only

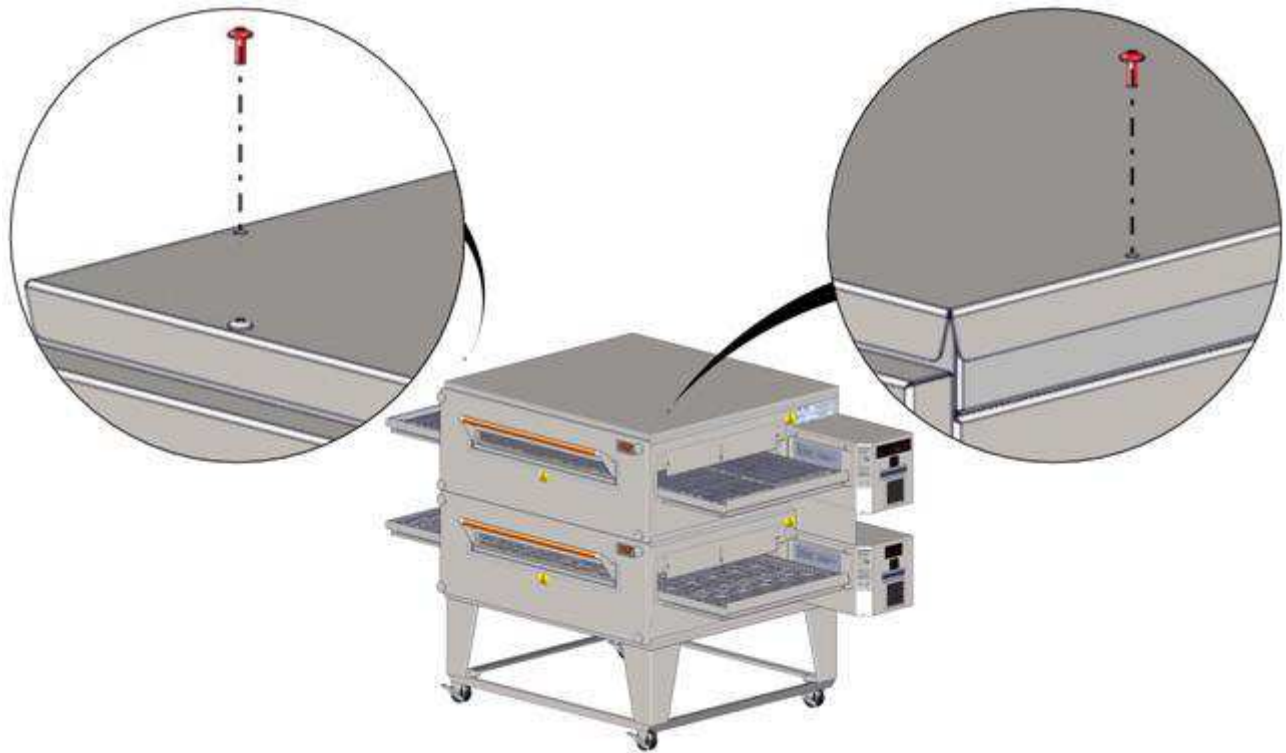

Prepare Ovens - Control Box Closeout Bracket

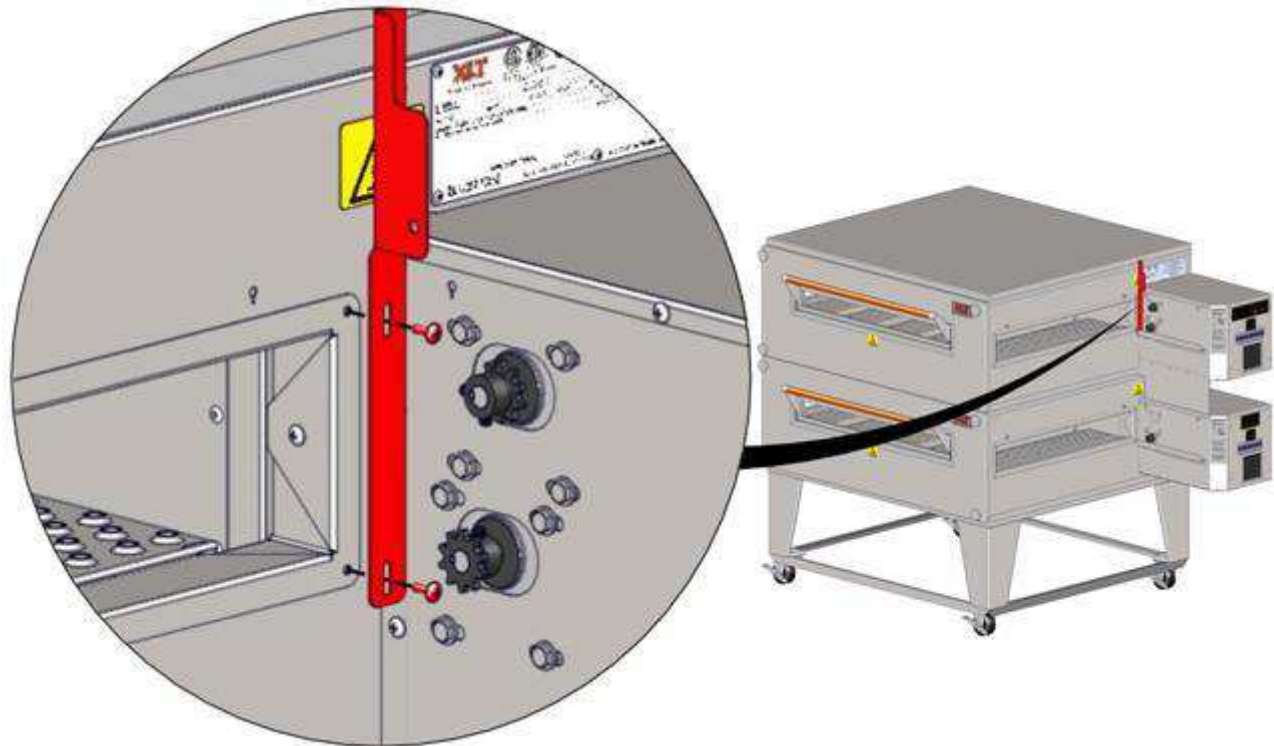

Conveyors have been removed for clarity

Prepare Ovens - Front Shroud Brackets

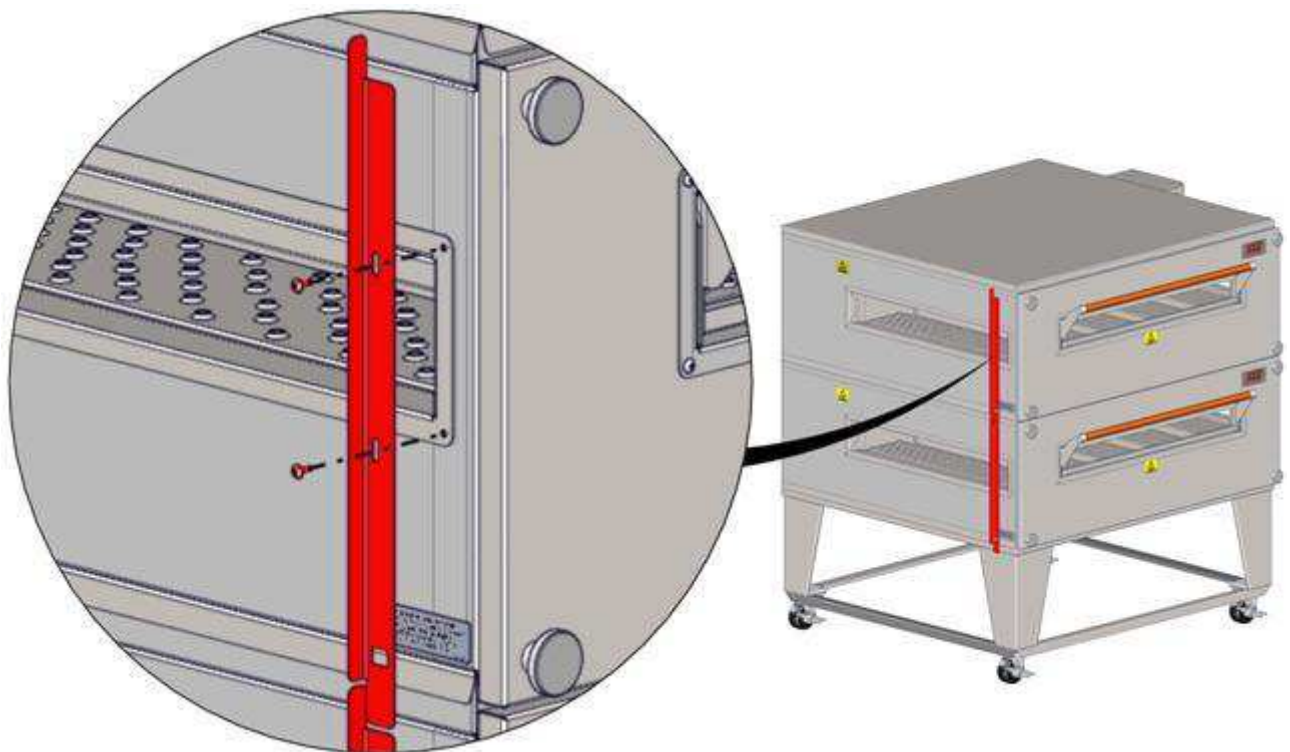
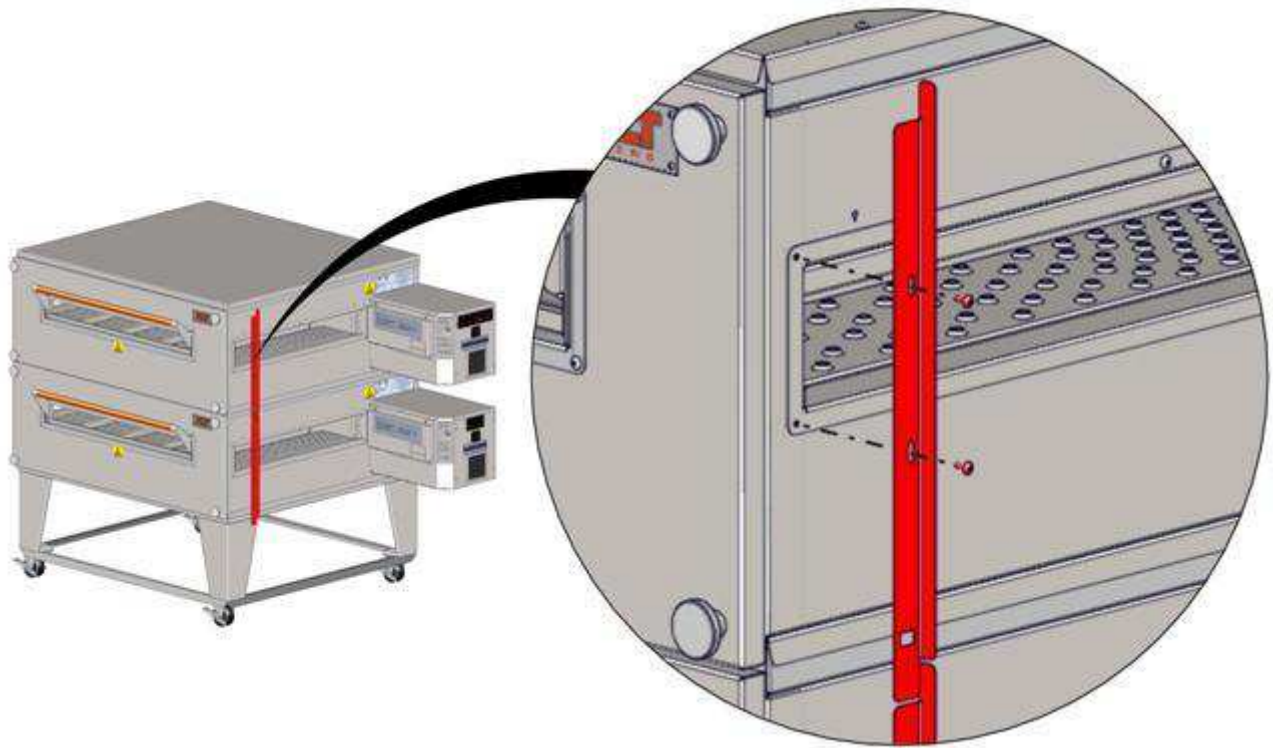

Prepare Ovens - Bottom Rail Bracket

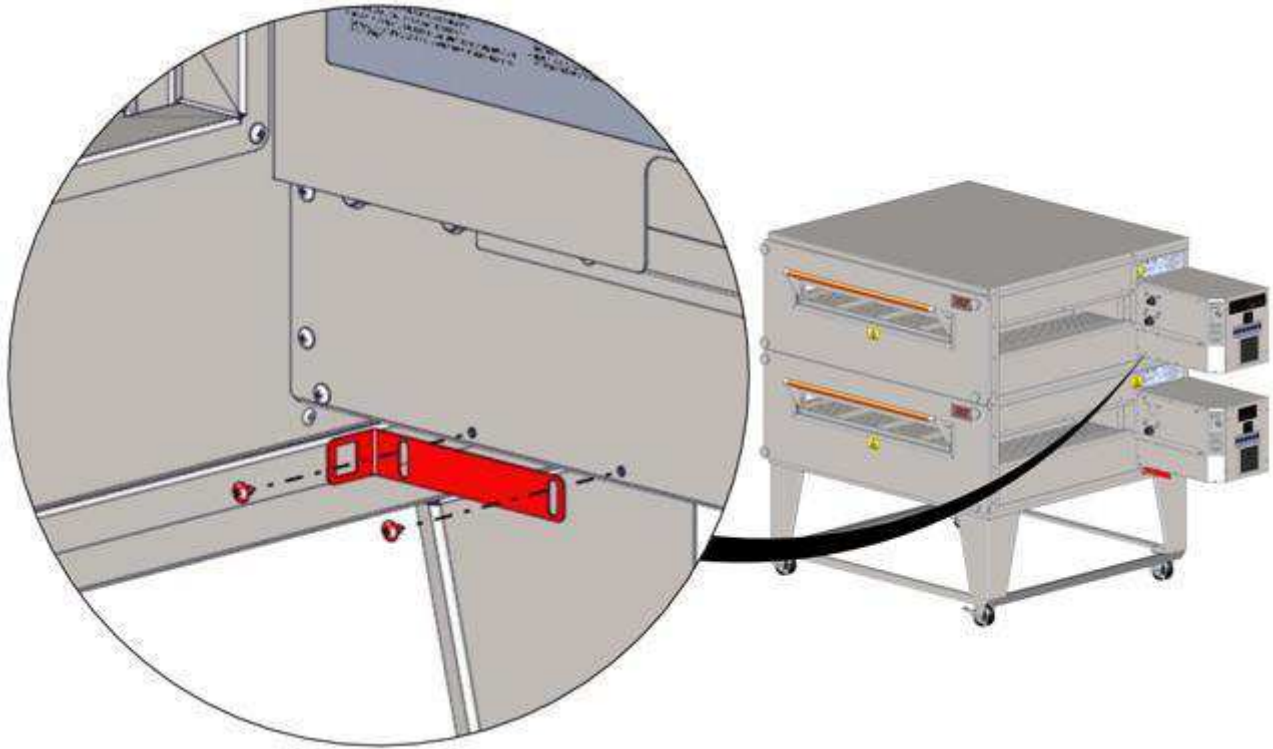

Prepare Ovens - Control Box Side Closeout

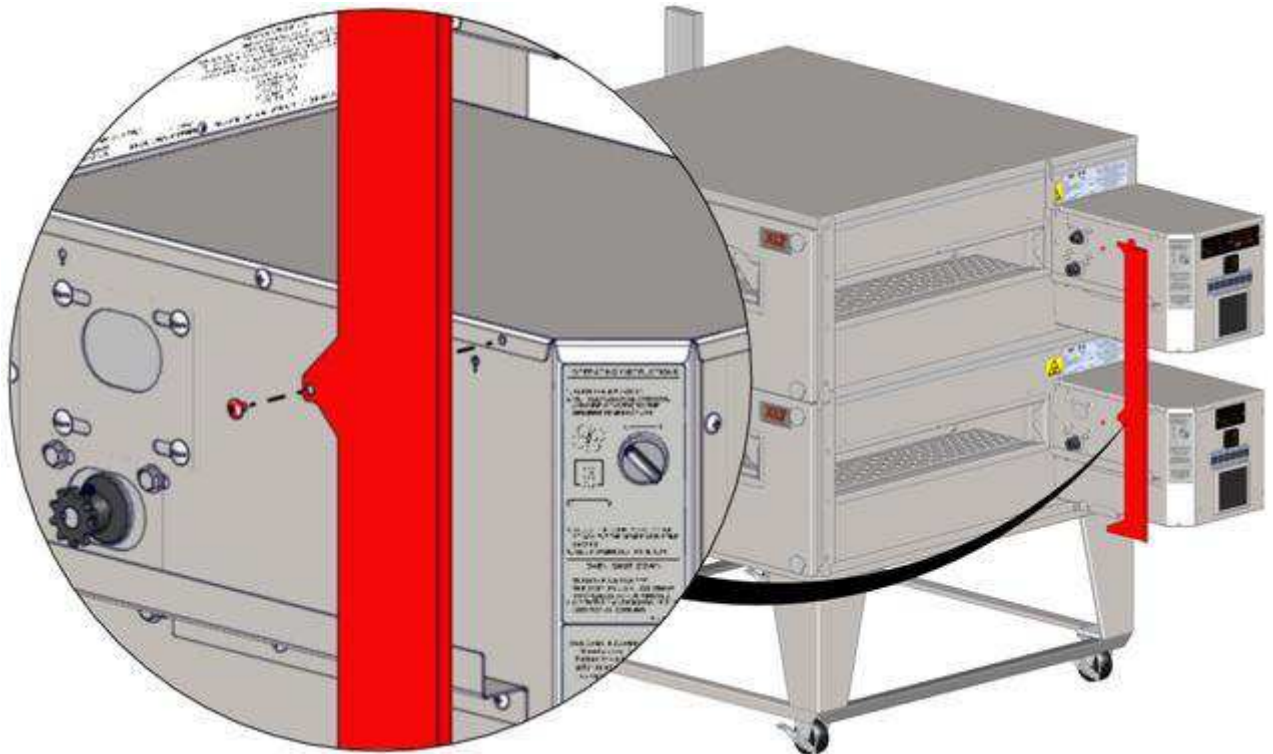

Prepare Ovens - Rear Shroud Brackets

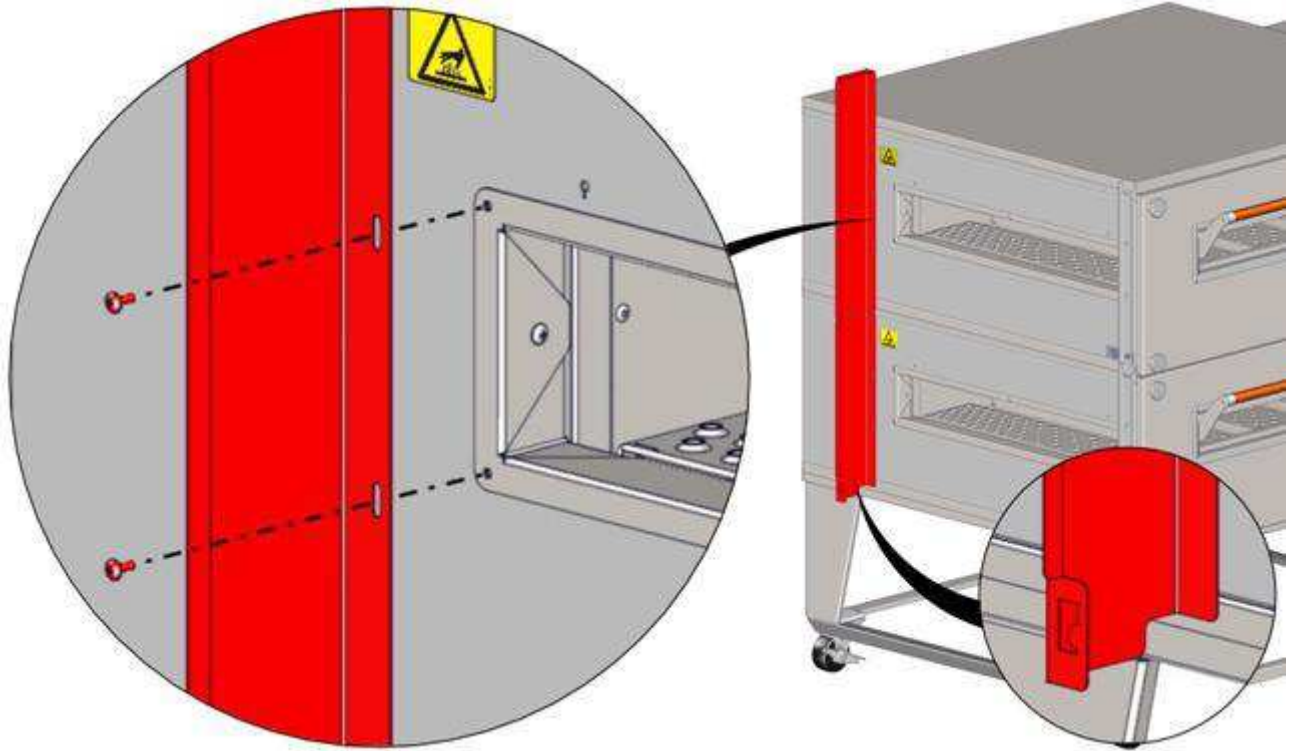

Prepare Hood

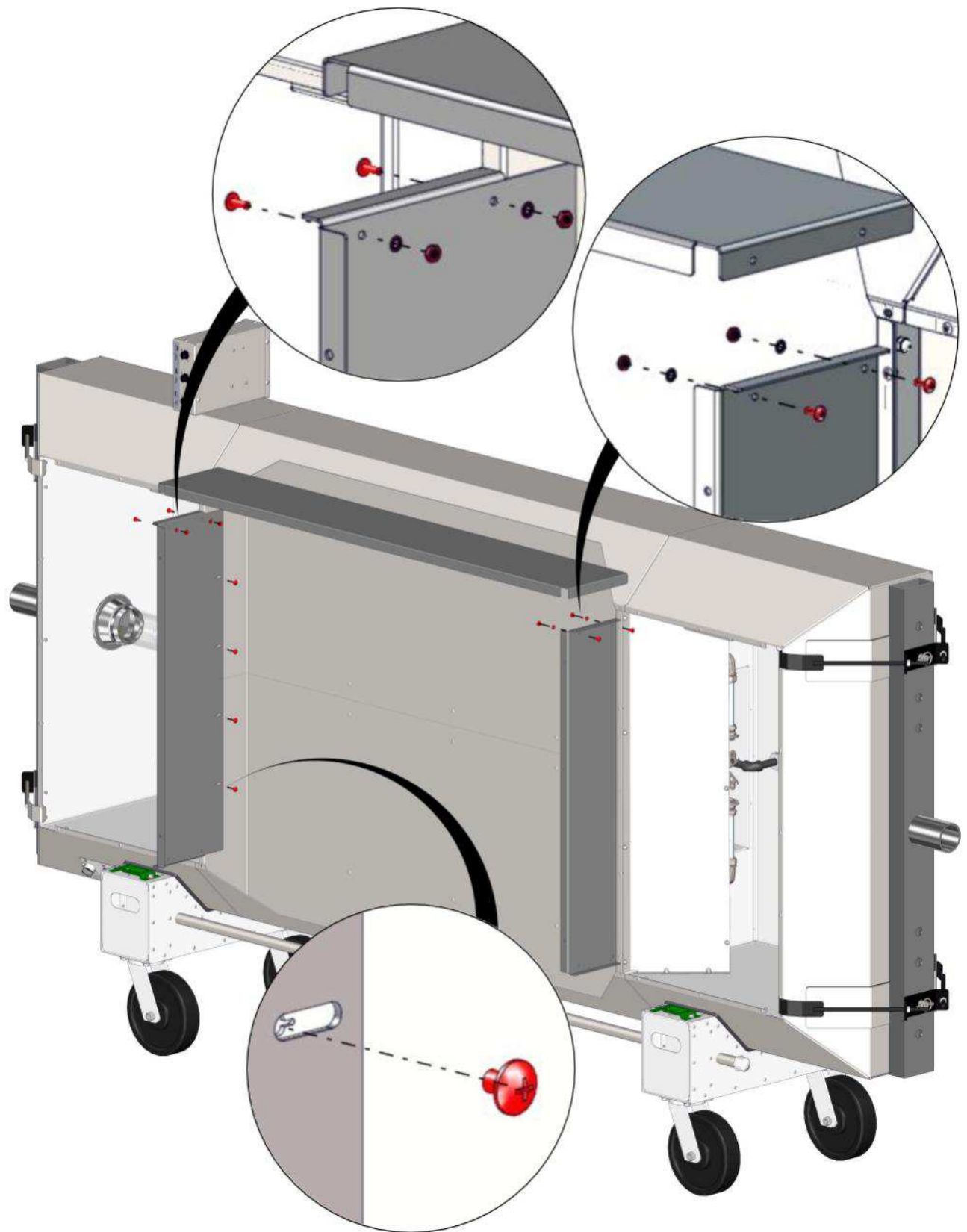

Lifting Gear Setup

AVI hoods can easily be moved and stacked with the proper lifting equipment. The use of XLT approved lifting equipment is highly recommended. Contact XLT for more information.

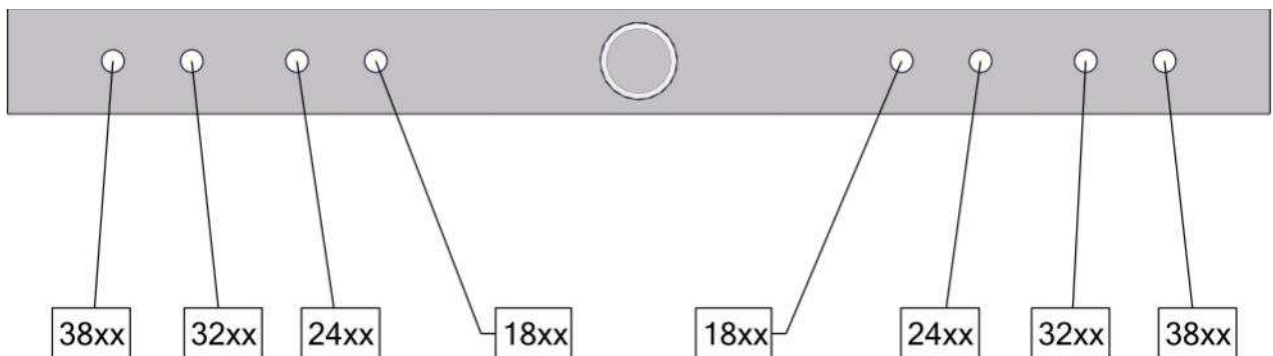
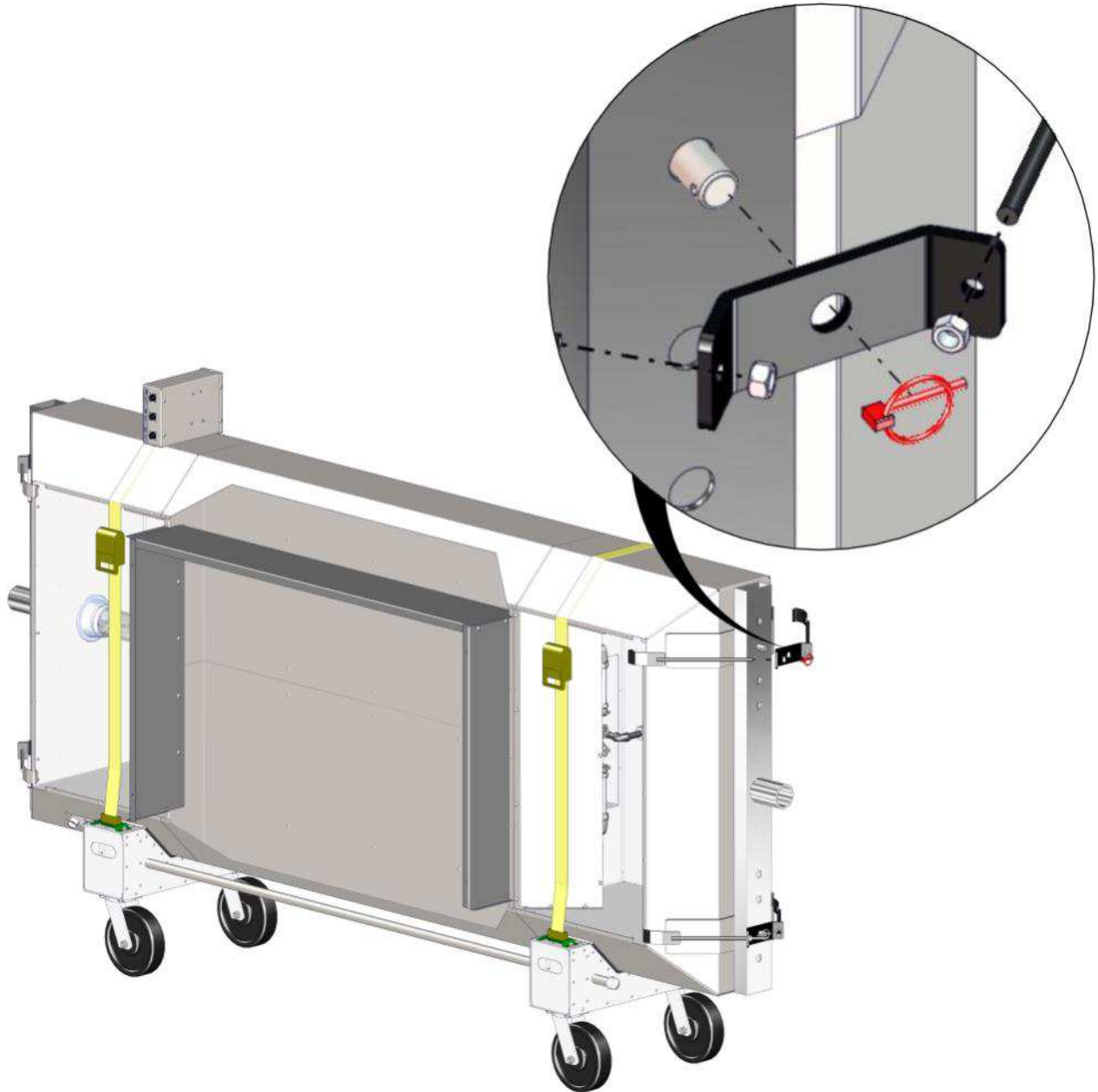

Lifting Jack Setup

**WARNING**

- Check for smooth operation. The cable should not be pinched & should pass smoothly over the pulley on top of the pole assembly.
- Inspect cable prior to each use.
- If cable is frayed or shows signs of excessive wear & tear, **DO NOT USE** until cable is replaced.
- At a minimum replace the cable annually with wire rope that meets or exceeds the jack manufacturer's specifications.
- Do not exceed the stated capacity of the jack.

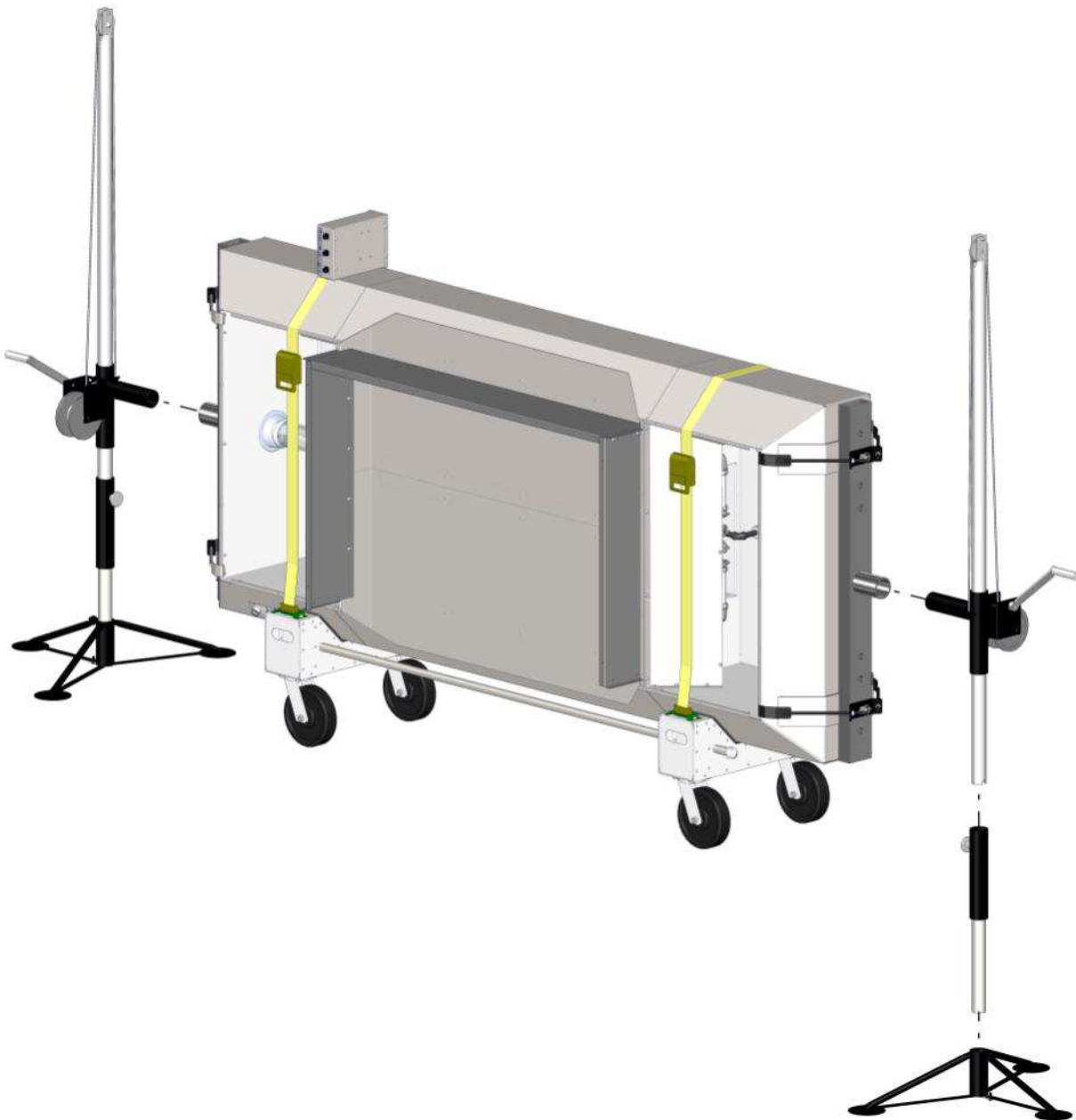

Stacking Hood on the Ovens



WARNING

Failure to engage the Lifting Jacks into the Lifting Pipe properly and completely will result in damage, injury, or death from a falling hood.



WARNING

- Both jacks should be raised in unison, otherwise they may bind and a dangerous situation will develop.
- Do not put any part of yourself under the hood at any time.
- The hood is top heavy. Be careful.

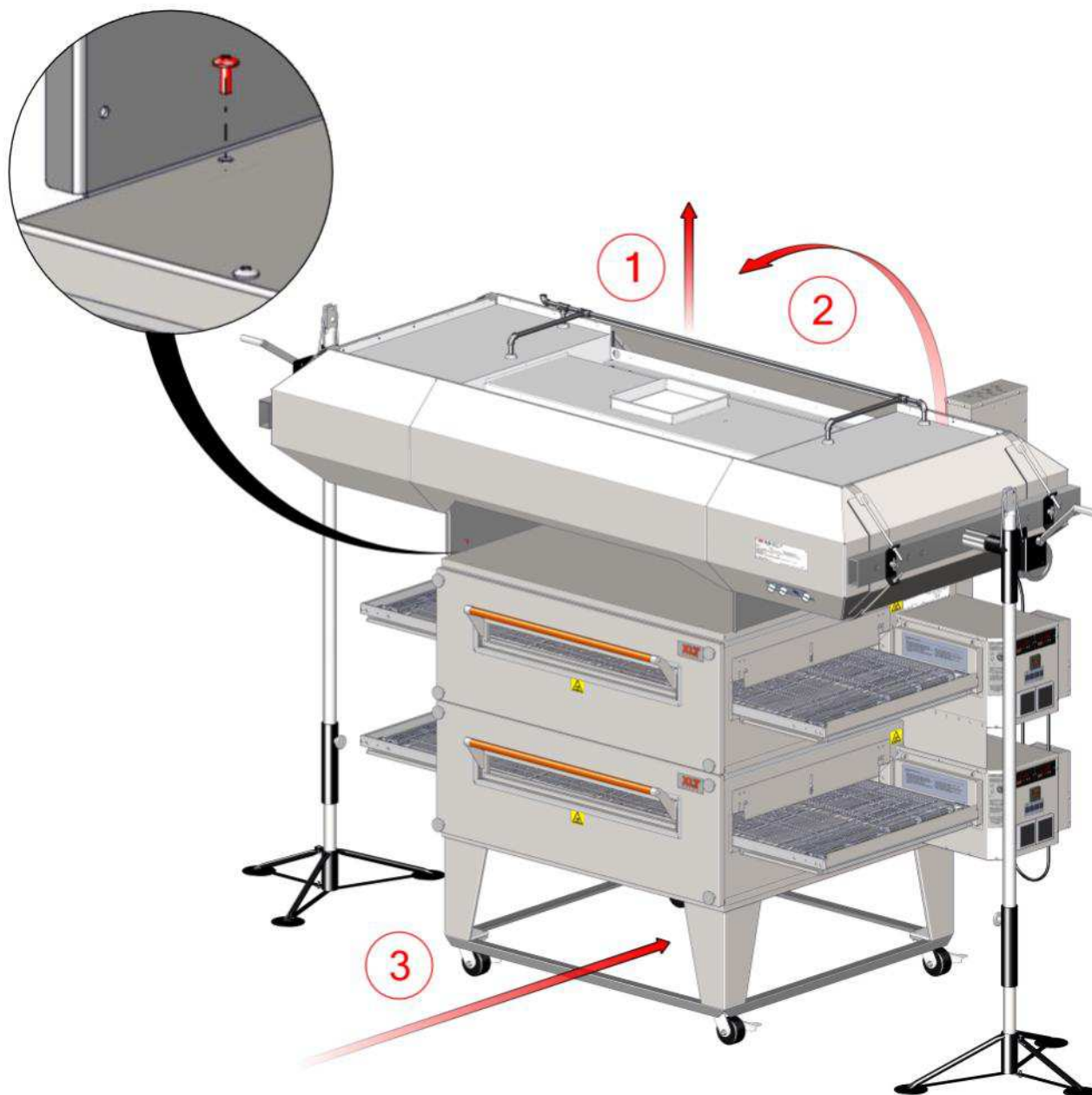

Hang Hood From Ceiling Joists

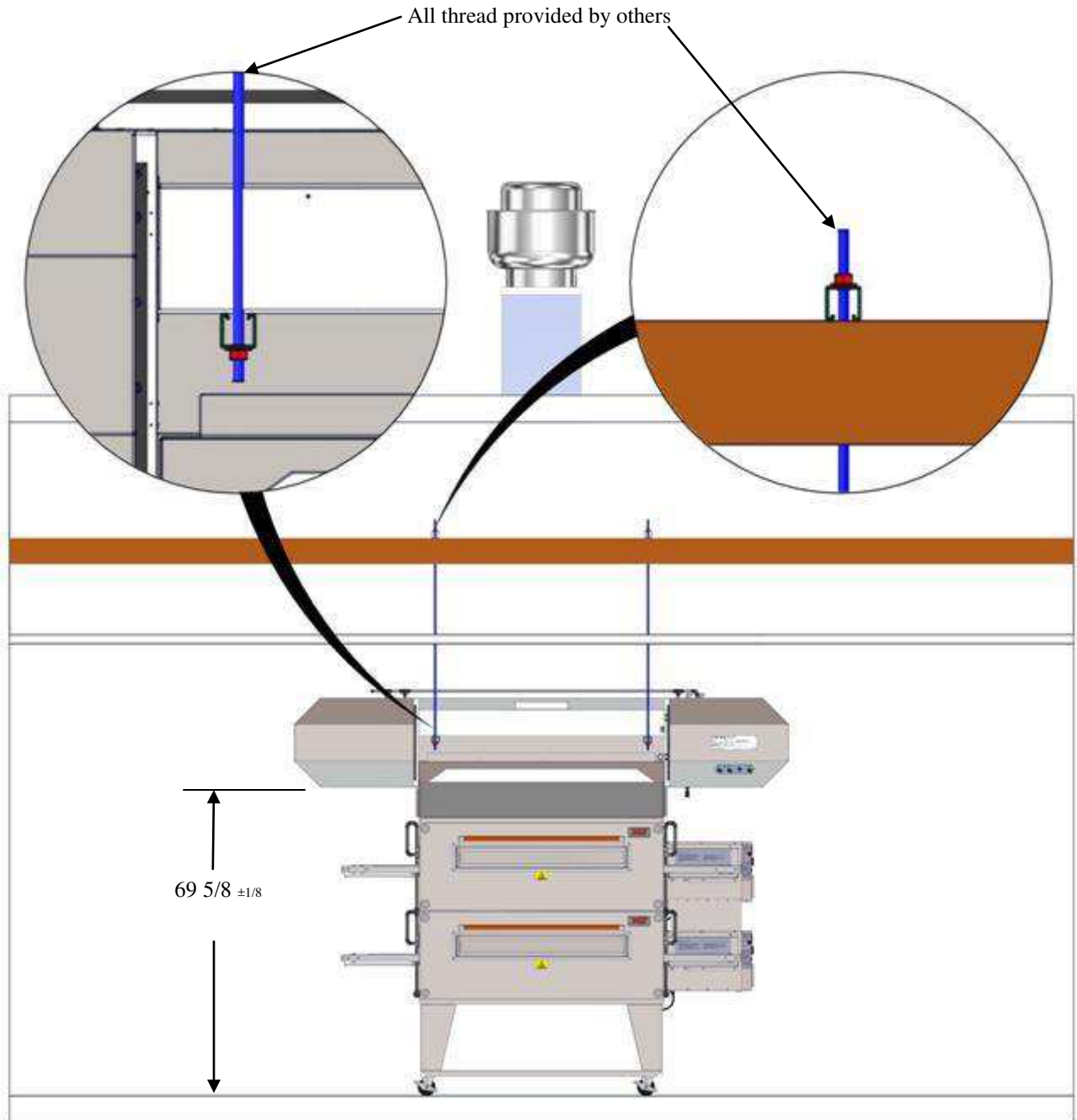

Install Grease Trays, Light Bulbs & Covers, and Grease Filters

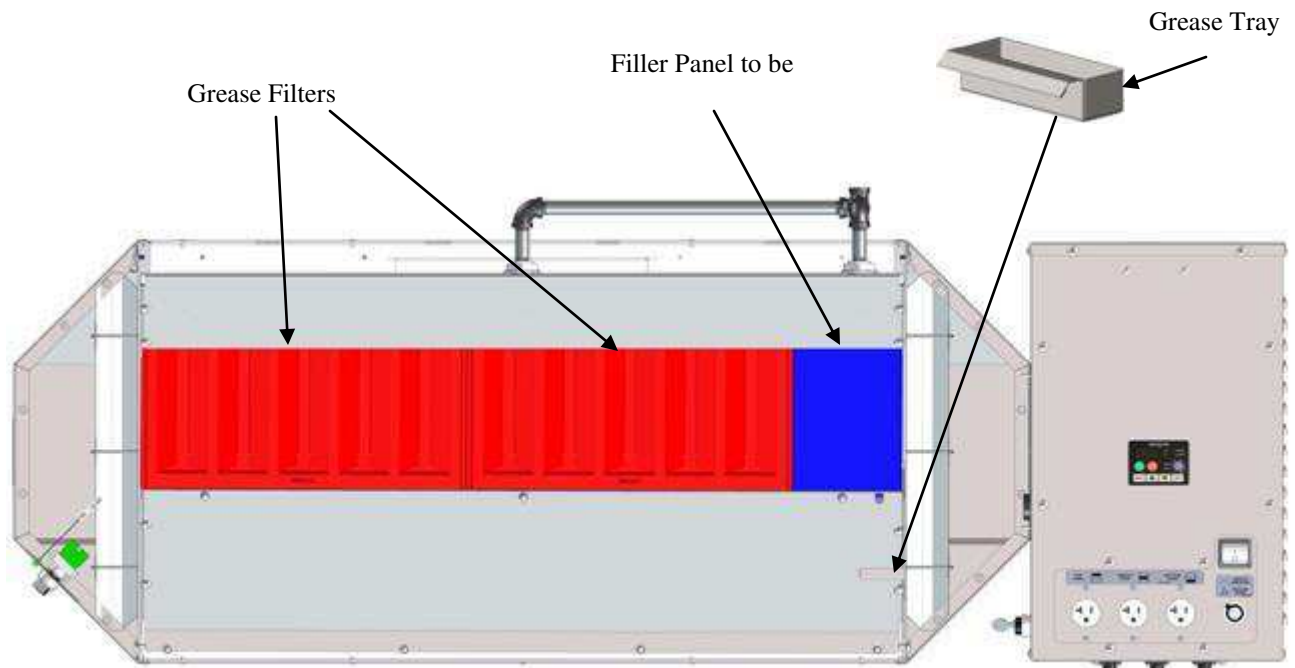
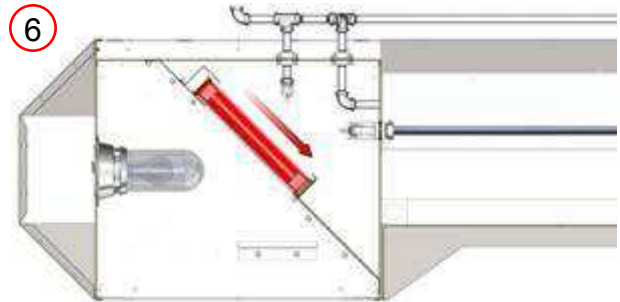
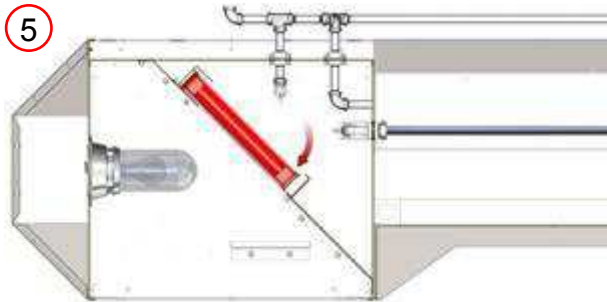
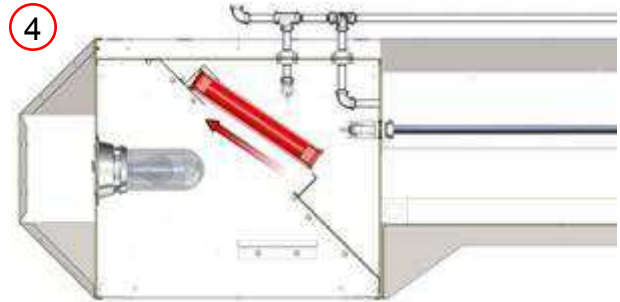
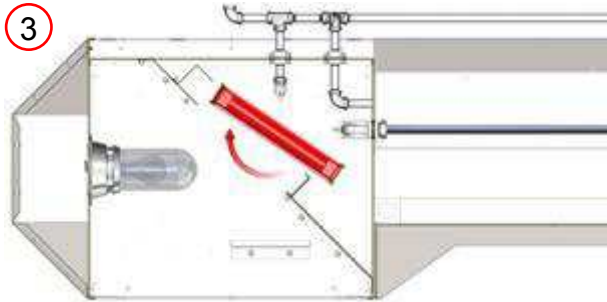
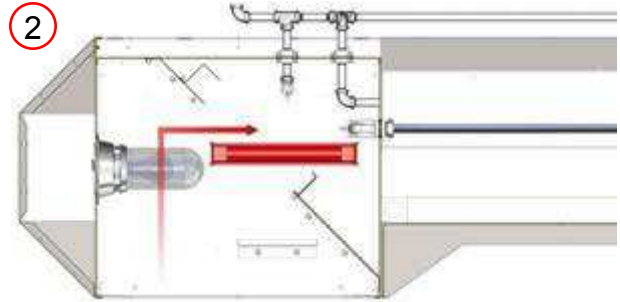
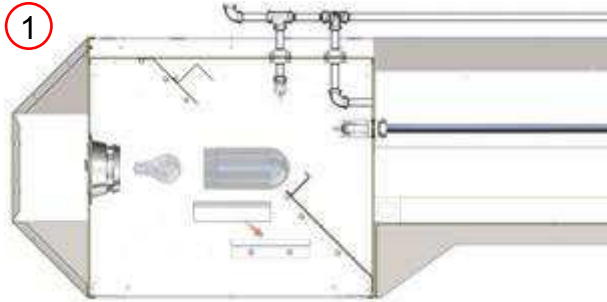

Install Shroud Hanging Brackets

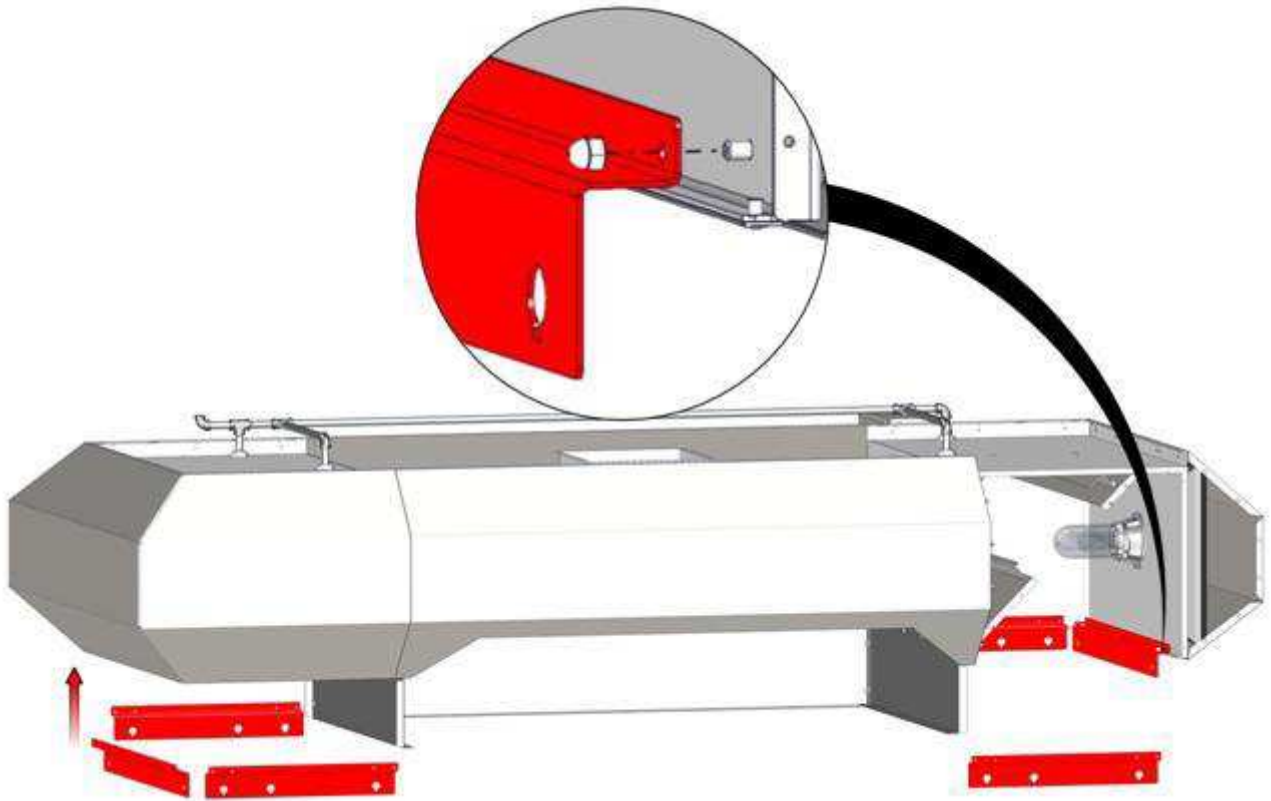

Install Corner Posts

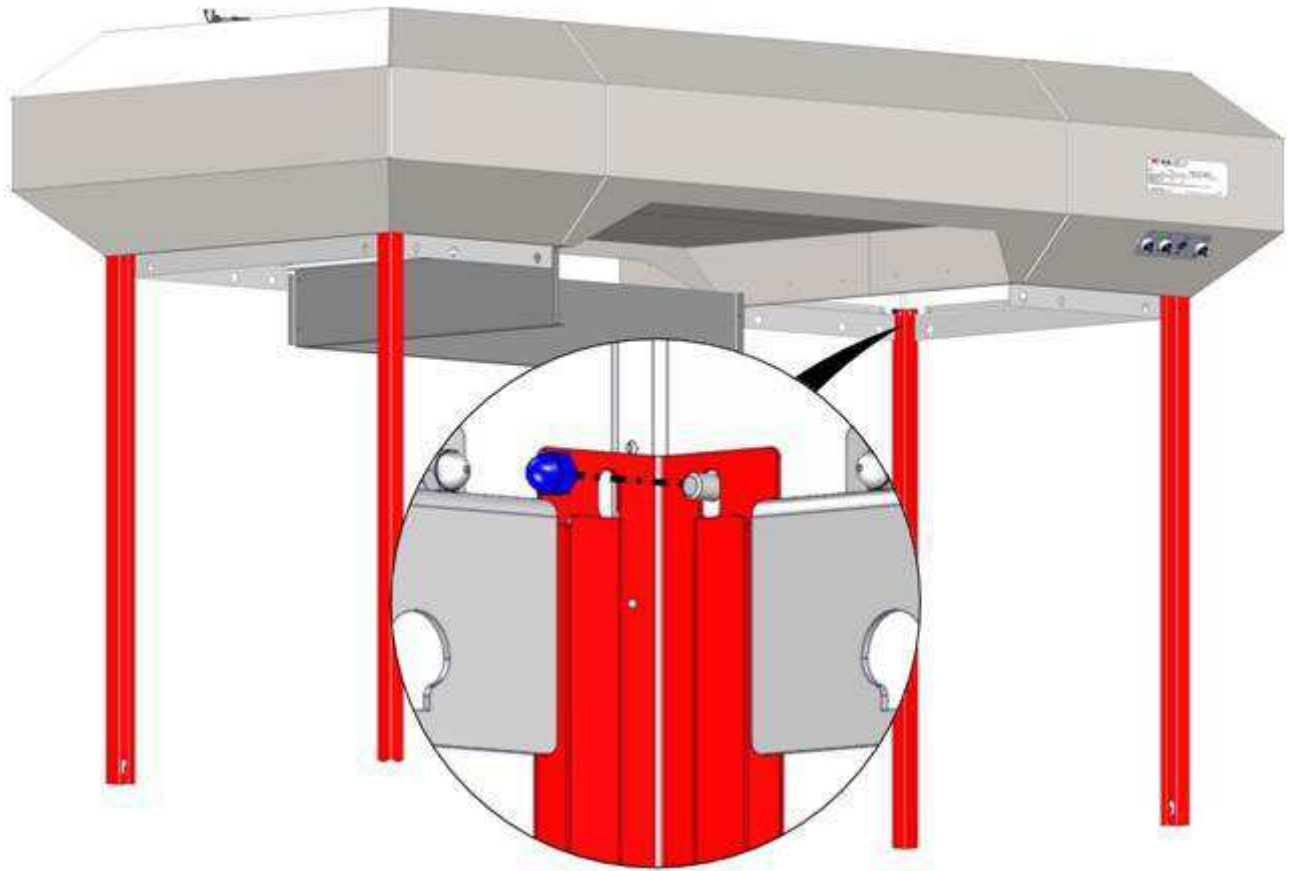

Install Bottom Rails

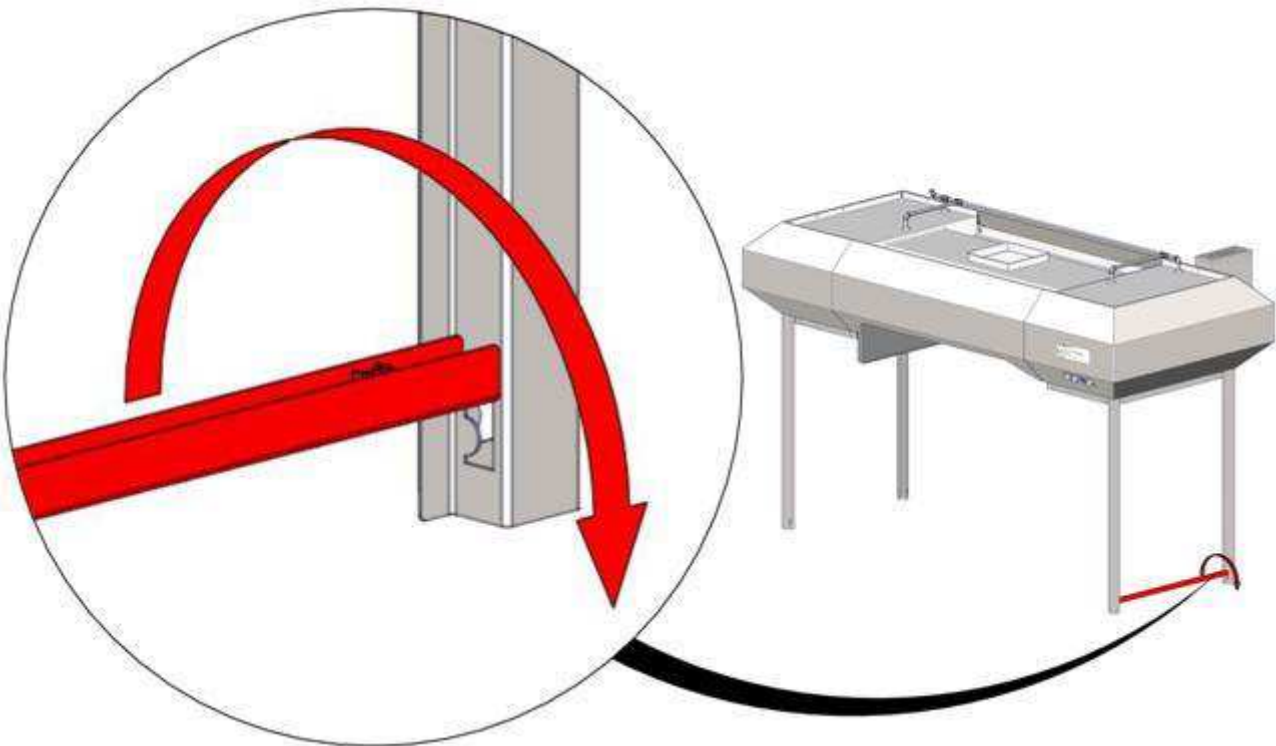
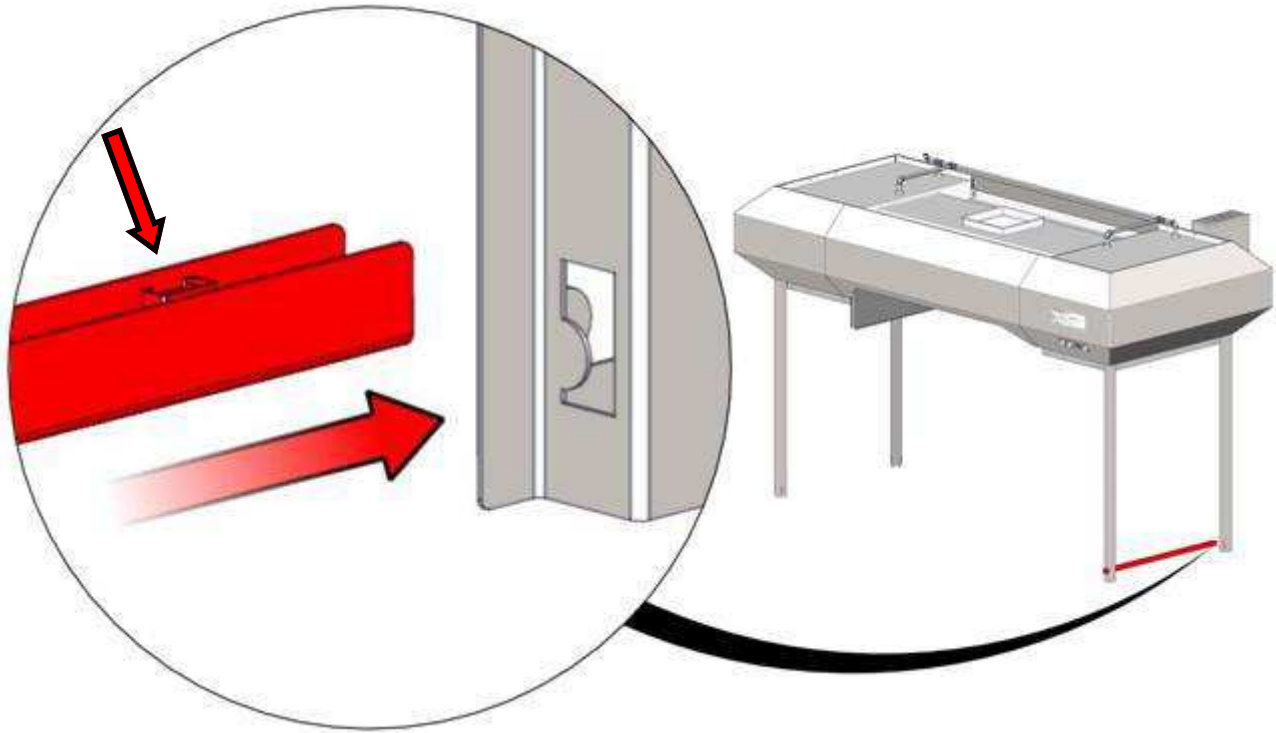

Install Bottom Rails

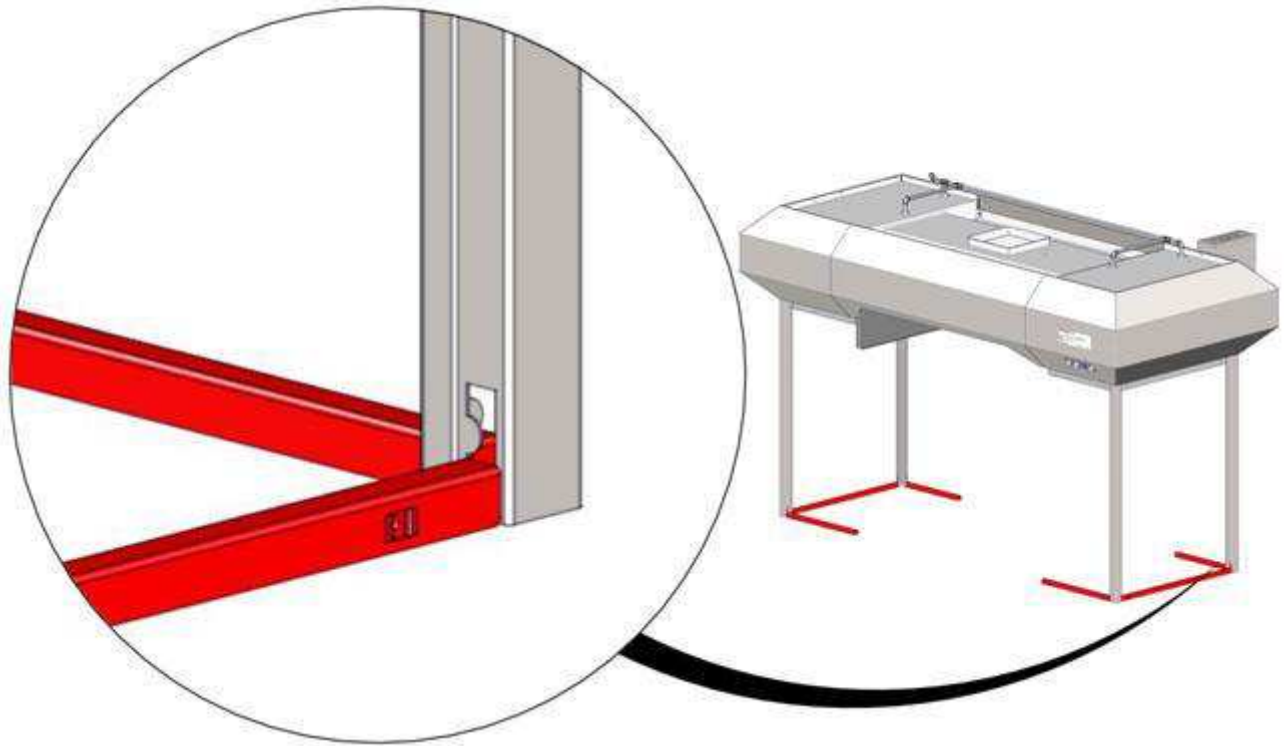

AVI HOOD INSTALLATION

Install Control Box Upper Closeout

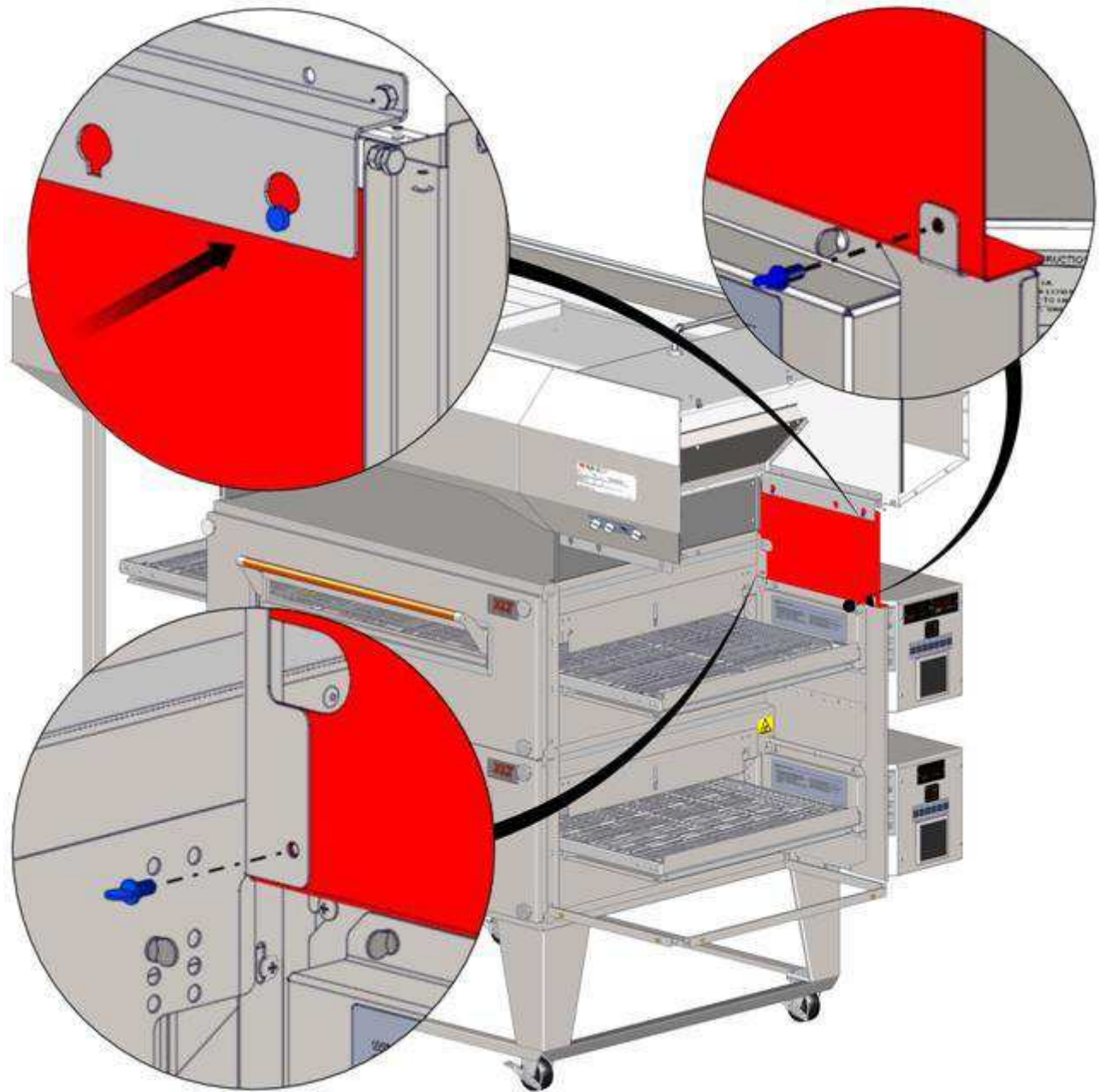

Install Shroud Panels - Front and Ends

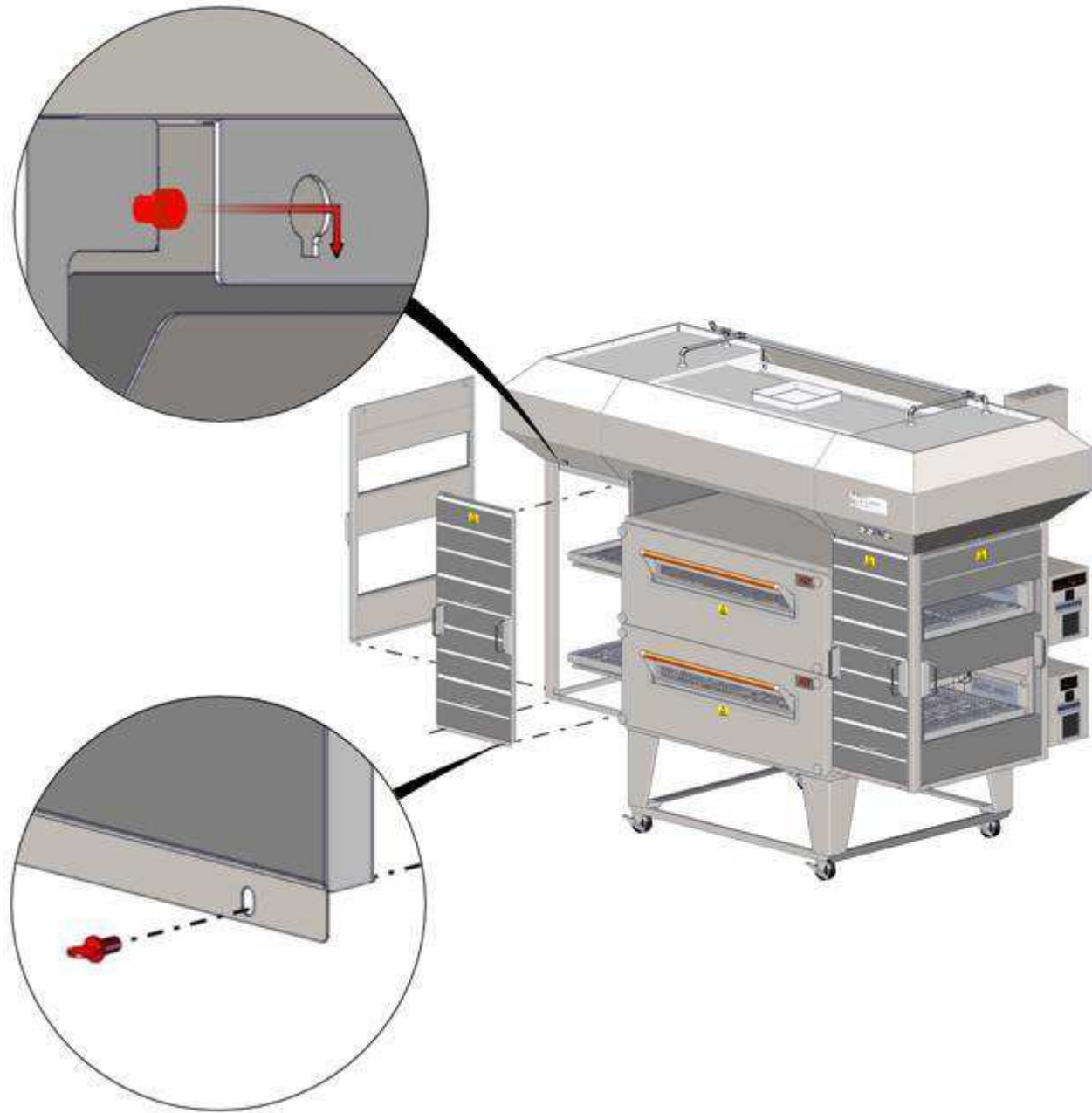

Install Back Shroud Panel



Install Hood Control Cord Assembly

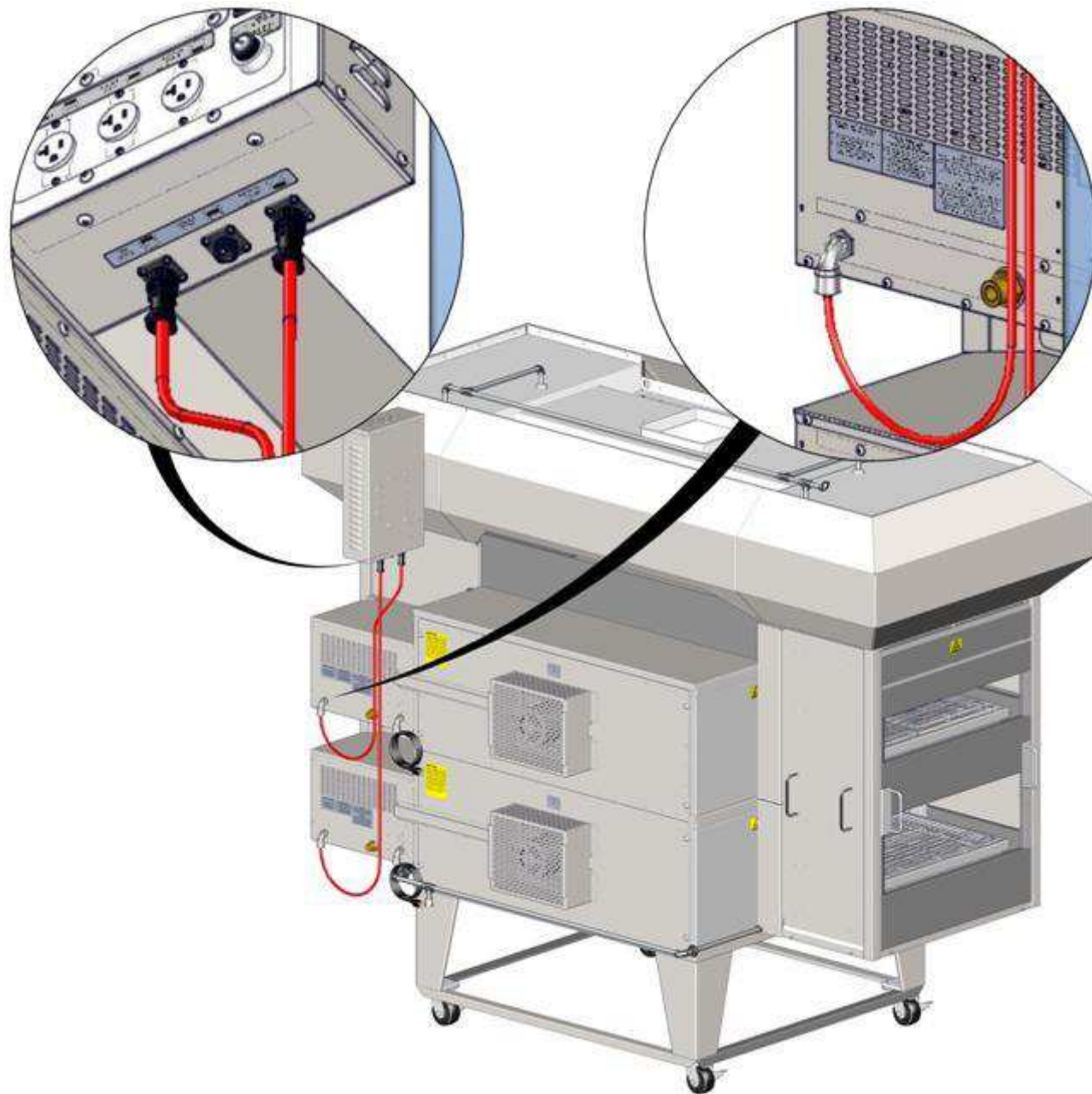

All hoods are outfitted with three (3) control cord outlets, regardless of how many XLT Ovens are installed. For a single oven use “Top” location. For a double stack use “Top” location for upper oven and “Bottom” location for lower oven, leaving “Middle” location open.

Insert and lock each oven control cord into the designated location on the bottom of the hood control box.

AVI HOOD INSTALLATION

Connect Hood Control Cord Assembly

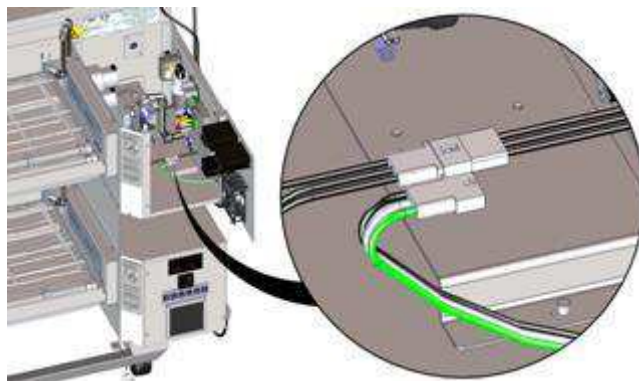
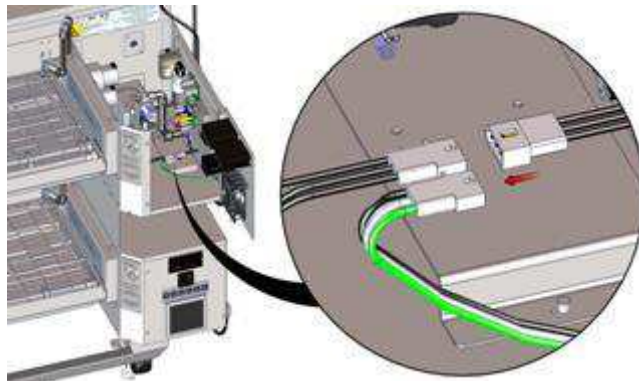
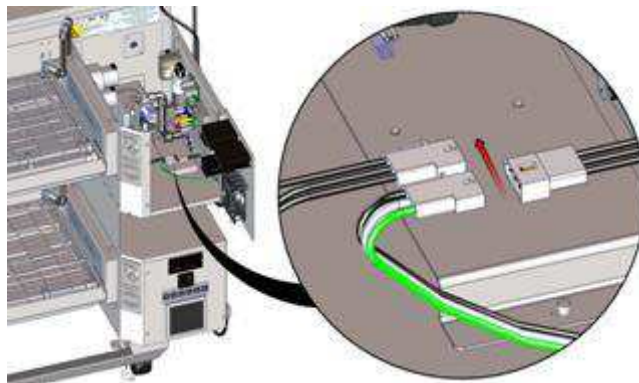
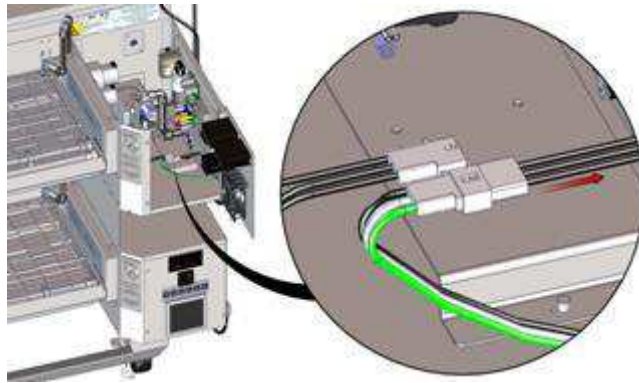

Variable Frequency Drive Adjustments

All AVI Hoods are functionally tested at the factory. Operation is verified, and adjustments are made to ensure proper operation. However, field conditions are sometimes different than factory conditions. These variables make it necessary to have an authorized service technician verify operation and make field adjustments if needed. The following items must be checked and verified to meet the specifications and requirements stated in this manual prior to the hood being commissioned:

- **Correct fan rotation.**
- **Balanced make-up air.**

The Initial Start-Up Checklist must be completed at time of installation, signed by the Customer and returned to XLT Ovens to initiate Warranty Policy.

The VFD controller is adjusted at the factory to the values displayed in the chart below.

VFD Controller Settings						
	Switches On			1832, 1855 & 2440	3240, 3255 & 3270	3855 & 3870
	Top	Middle	Bottom			
Single	X			20 Hz	25 Hz	30Hz
Double	X			20 Hz	25 Hz	30Hz
			X	35 Hz	40 Hz	45 Hz
	X		X	35 Hz	40 Hz	45 Hz
Triple	X			20 Hz	25 Hz	30Hz
		X		30 Hz	35 Hz	40 Hz
			X	40 Hz	45 Hz	50 Hz
	X	X		30 Hz	35 Hz	40 Hz
	X		X	40 Hz	45 Hz	50 Hz
		X	X	40 Hz	45 Hz	50 Hz
	X	X	X	45 Hz	50 Hz	55 Hz
Fire Suppression				60 Hz		

If you require either more or less air flow, follow these steps:

1. Turn at least one (1) oven switch ON. The VFD display should show the POWER and RUN LED lamps lit up, and a numeric value should appear in the window display.

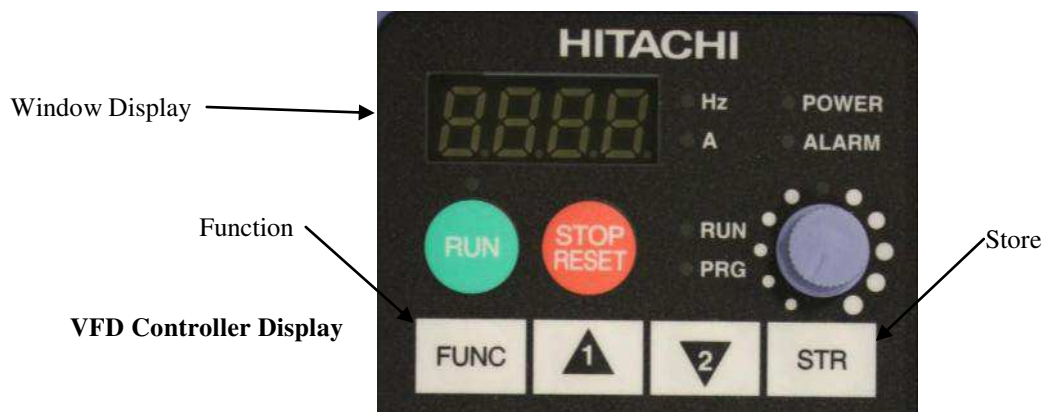

2. Press & hold the function key until <d001> displays.
3. Use the up / down arrows to reach <F001>.
4. Press the function key one (1) time. A frequency will display according to the switches that are ON per the chart below.
5. Turn all oven switches OFF. The display should read <0.0>.
6. Turn ON the oven switches to be set. For example, both Top and Bottom ovens, or Top oven only, or Bottom oven only, etc.
7. Press the Up/Down arrows until you reach the desired initial settings.
8. Press the store button once to store the new setting.
9. Repeat steps 6-8 for additional settings as needed.
10. When finished, turn all of the oven switches to the OFF position.
11. Press the <FUNC> key until <d001> appears in the display.
12. Press the <FUNC> one more time. The actual frequency will appear in the window display.
13. Press the <STR> button one time to store the values.

The control switches are located on the front of the hood.

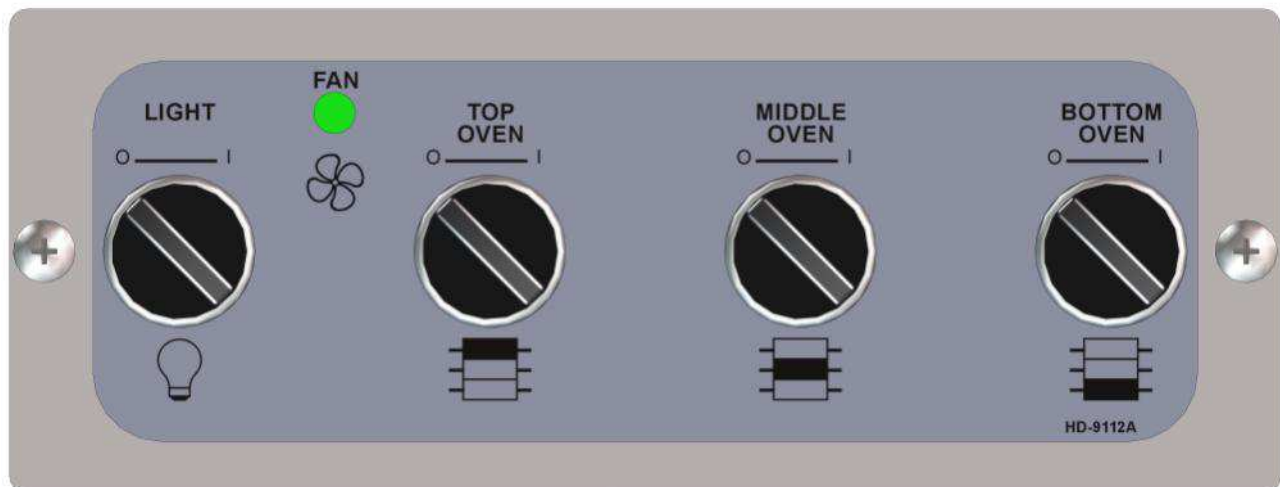

NOTE → When XLT Ovens are outfitted with AVI Hoods, the main switch on the oven is disabled and no longer operates. The switch on the AVI Hood overrides the oven switch.

Hood Operation

1. Turn the light switch on.
2. Turn the desired oven switch on. Refer to the Oven start-up section for instructions on how to adjust temperature and conveyor speed. The oven(s), exhaust fan, and make-up air unit will be activated by this switch if the AVI Hood is installed according to this manual.
3. When additional oven switches are turned on, the VFD will automatically increase the exhaust fan speed.
4. When shutting down the ovens, turn the desired oven switch off. The make-up air unit will shut off. The ovens and exhaust fan will shut off after about 30 minutes. Refer to the Oven shutdown section for instructions.
5. Do not press the <STOP/RESET> switch on the Variable Frequency Drive itself. The RUN and POWER LED should stay lit all of the time.

The valance kit size is determined by AVI Hood size & distance from the finished floor to the installed drop ceiling height. The valance kit screws directly to the AVI Hood & does not require any structural support. All kits have provisions for hood fire suppression piping to pass through without modification. The plastic coating must be removed from all parts prior to installation.

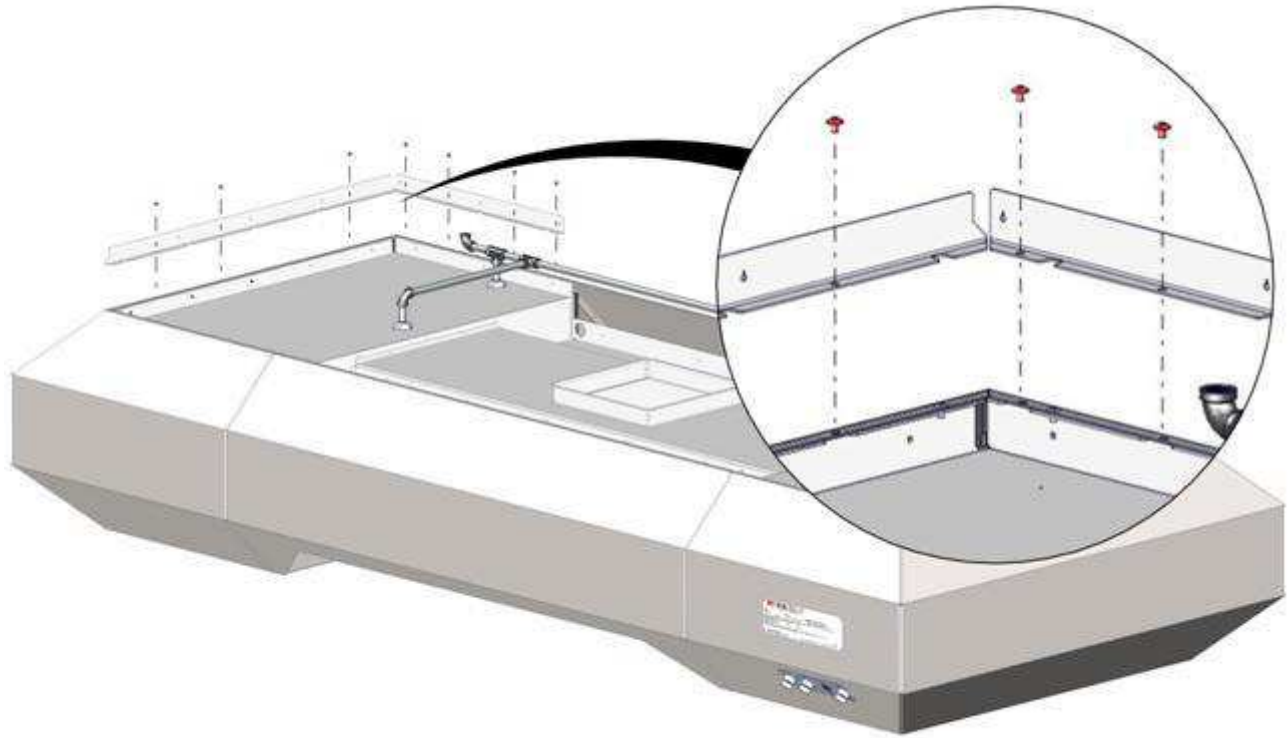
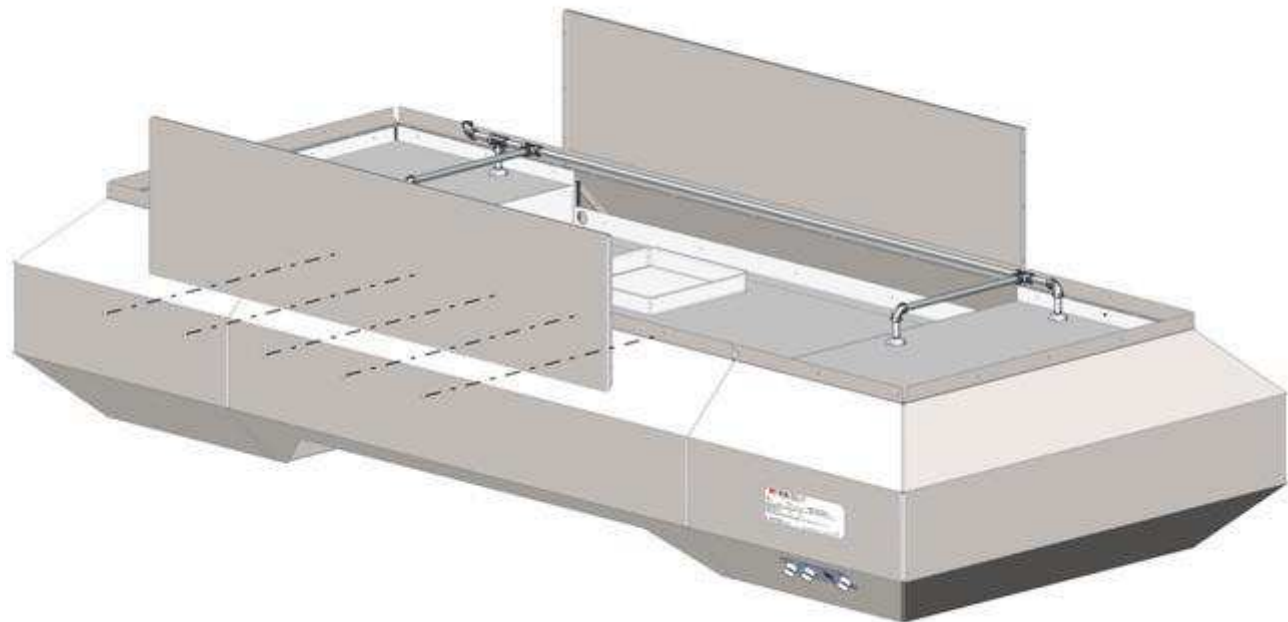

AVI Hood valance kits are available for different floor to ceiling heights. Contact XLT Ovens or your designated representative for more information.

Install Valance Brackets**Install Front & Back Panels**

Install Corner Panels

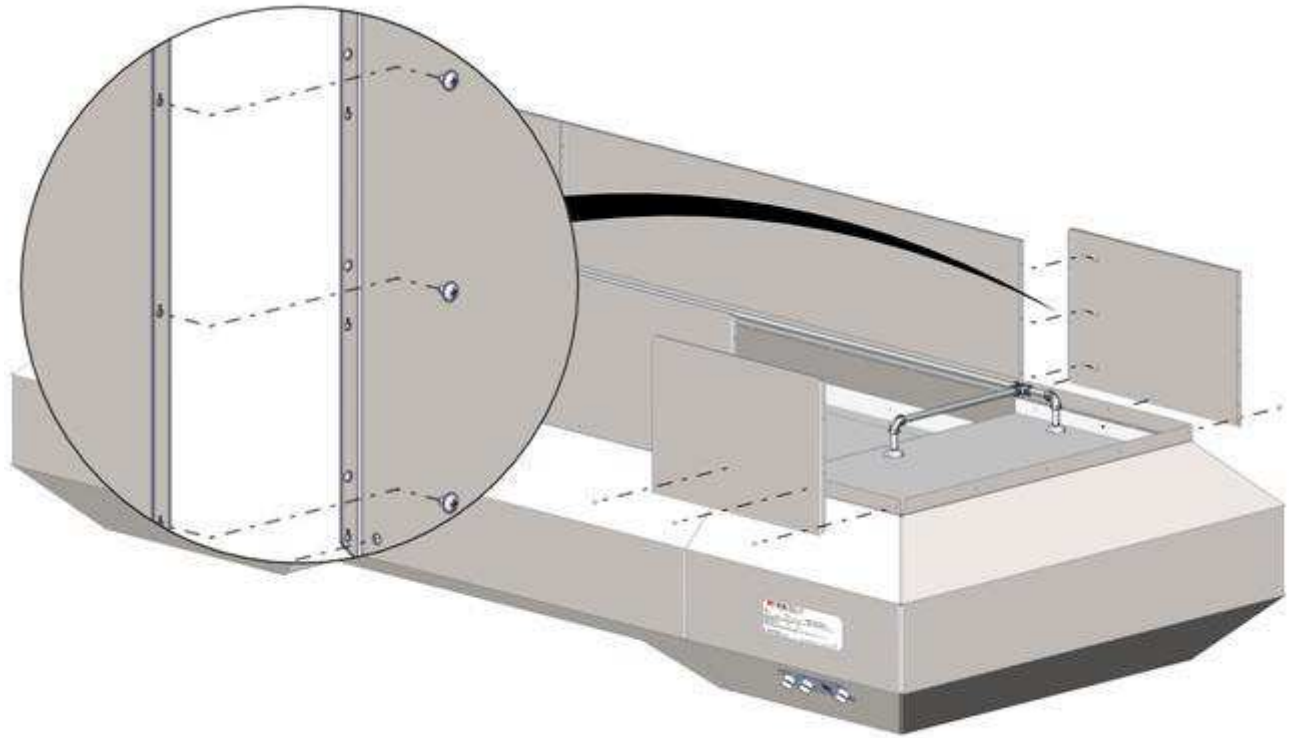

Install End Panels

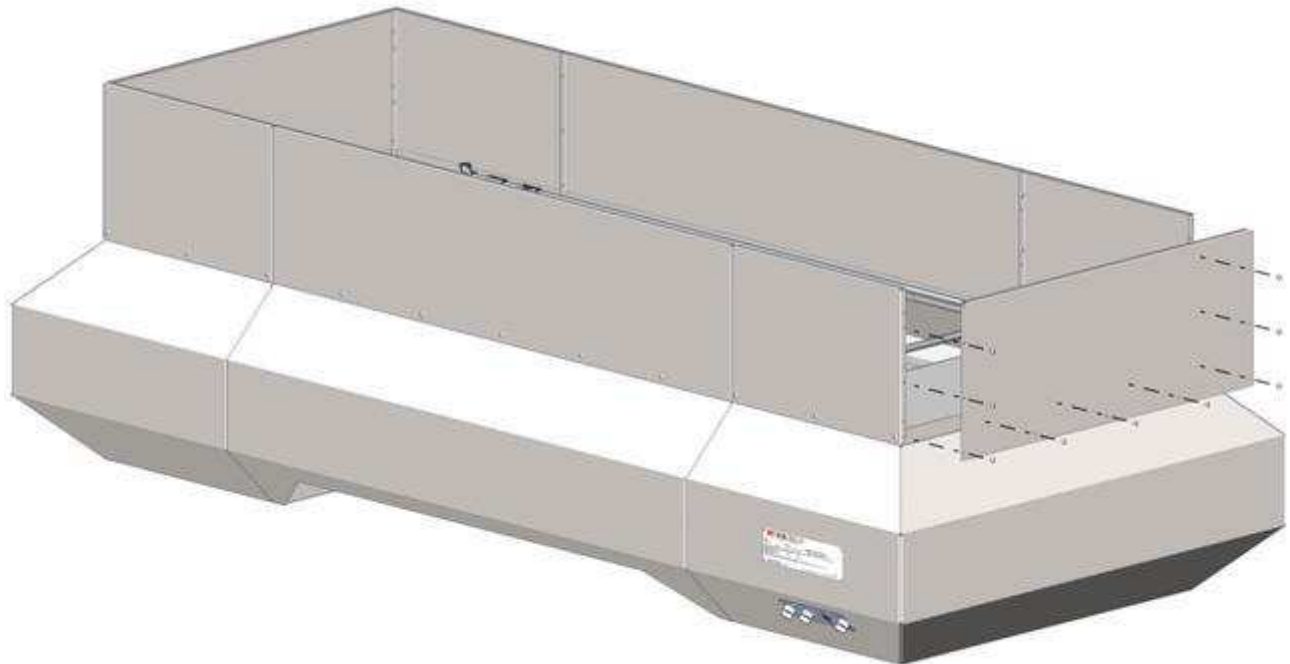

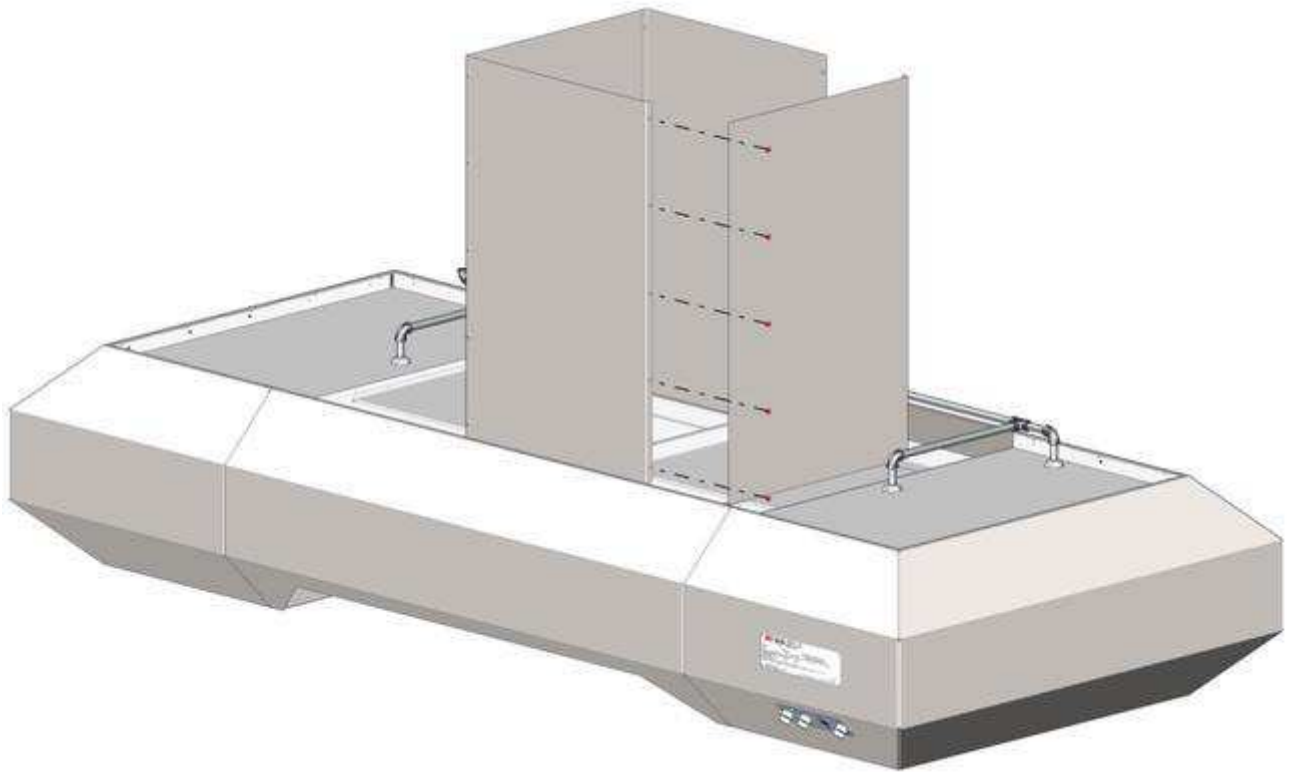

Your AVI hood is constructed of stainless and aluminized steel. Check application restrictions on product label prior to usage. Observe recommended precautionary and safety measures as dictated by the product manufacturer.

Do not use abrasive or caustic cleaners. Abrasive pads will scratch stainless steel surfaces. Areas with heavy buildup should be sprayed and allowed to soak for up to 5 minutes prior to wiping clean. Always wipe with the “grain” of the surface to maintain appearance.

Hood Cleaning & Maintenance Schedule						
	Daily	Weekly	Monthly	Semi-Annual	As Required	
Cleaning						
Wipe down Front, Sides, & Top	?					
Clean Light Globes	?					
Empty & Clean Grease Trays	?				?	
Clean Grease Filters		?			?	
Clean Duct and Exhaust Fan			?		?	
Inspection						
Check Indicator Lamp	?					
Check Grease Trays	?					
Check Grease Filters		?				
Adjust						
No Adjustments Necessary						
Lubricate						
No Lubrication Required						
Replace						
Light Bulbs					?	

Schedule provided as a guide only. Frequency of cleaning may vary as needed.



WARNING **Oven must be cool and the electric cord unplugged before any cleaning is done.**



CAUTION **Shroud Panels can weigh up to 60 lbs [27 kg]. Use caution when lifting.**



CAUTION **DO NOT spray liquid cleaning agents in the slots & holes of the following locations:**

- Hood electrical box (located on back of upper portion)
- VFD Controller
- Back of control box
- Underneath control box

Refer to the Hood Installation Section for disassembly and reassembly.

Before troubleshooting the hood:

1. Make sure that the RUN lamp and POWER lamp are lit.
2. Check to see that the breaker in the service panel is not tripped.
3. Check to see that the breaker on the hood electrical box is not tripped.
4. Make sure the Switch Relocation Cords (SRC) are properly installed to the oven(s).
5. Check to see that the grease filters are clean & installed properly.
6. Check to see if the exhaust fan is rotating in the correct rotation. (applies to new installations)

In the occurrence that the VFD controller has an ERROR Code displaying. Follow these steps to clear them.

Error Codes:

- E01-E04 Inverter output was short circuited
- E05 motor overload is detected by electronic thermal function.
- E07 DC bus voltage exceeds a threshold
- E09 DC bus voltage is below a threshold
- E14 Ground fault detected between controller output and motor.

Error Code Reset:

Check VFD display for error code and record it.

Clear error by pressing the <Stop Reset> button.

Press the <Run> button to activate exhaust fan.

Normal operation resumes with no error codes.

If error codes return press the <Stop/Reset> key and call XLT service.

If the corrective actions listed above do not correct the problem, then XLT has qualified customer service personnel that can provide assistance on any type of XLT Oven or AVI Hood problem you may experience. Customer Service is available at 888-443-2751 24/7/365, or visit www.xltovens.com. The website offers an interactive troubleshooting guide that can further assist in diagnosing problems.

For repairs or maintenance of the fire suppression system and components, contact the local Ansul dealer or XLT for assistance.

AVI VARIABLE FREQUENCY DRIVE (VFD) MANUAL MODE87

Standard Hoods ONLY

The manual mode feature was designed to offer temporary operation of the exhaust fan at full power if the VFD controller fails. Manual mode should not be used for normal day-to-day operation and should only be utilized during emergency situations. The operator should return the VFD controller back to normal run mode as soon as the VFD is repaired or replaced.

A key is supplied with the unit that unlocks both switches. The key must remain in keyed switch #1, Standard Mode, during normal operation.

If the VFD fails, then follow these steps:

1. Rotate keyed switch #1 clockwise to the OFF position.
2. Wait until the VFD LED display and the POWER indicator lamp goes completely blank.

NOTE: This may take up to 1 minute!



Do not turn this switch off or on without allowing the VFD controller to completely shut down.

CAUTION Failure to follow these instructions will result in damage to the VFD controller.

After the VFD Controller display has gone off:

3. Remove the key from keyed switch #1 and insert it into keyed switch #2.
4. Rotate keyed switch #2 clockwise to the ON position.

The exhaust fan should now operate at full speed, and can be turned ON & OFF from this switch.



Exhaust fan will run at highest speed (60 Hz) when in manual mode.

NOTE

As soon as possible, ensure the VFD is either repaired or replaced. After the VFD is returned to operating condition, then follow these steps:

1. Rotate keyed switch #2 counter-clockwise to the OFF position.
2. Wait for the exhaust fan to come to a complete stop.
3. Wait 5 minutes.



Ensure the exhaust fan has come to a complete stop before proceeding.

CAUTION Failure to follow these instructions will result in damage to the VFD controller.

After the exhaust fan has come to a complete stop:

4. Remove the key from keyed switch #2 & insert into keyed switch #1.
5. Rotate keyed switch #1 counter-clockwise to the ON position.
6. Press the green <RUN> button on the VFD Controller to reactivate standard mode.

The VFD controller should illuminate & show <0.0>. Follow the steps outlined in the VFD Adjustments section of this manual.

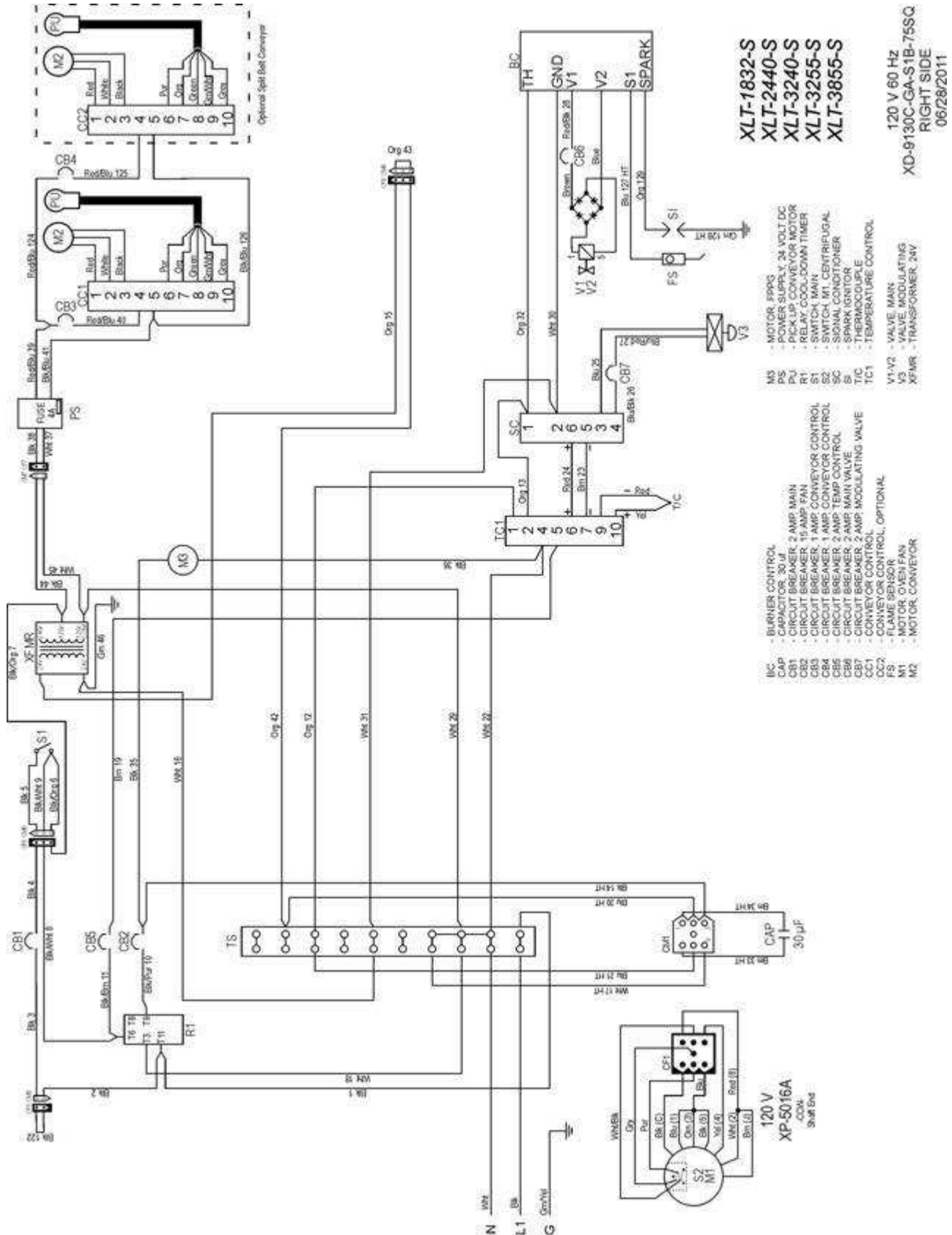

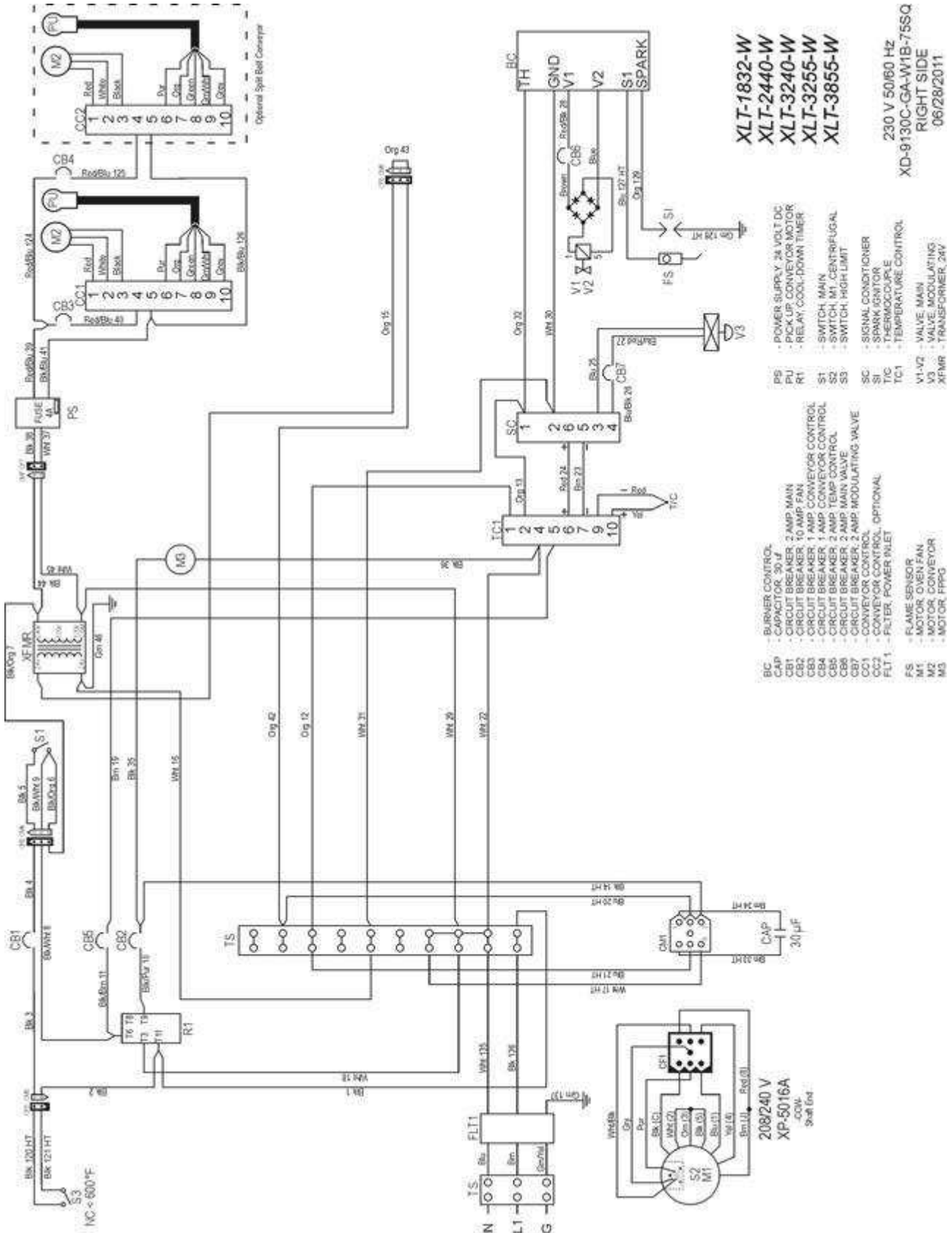

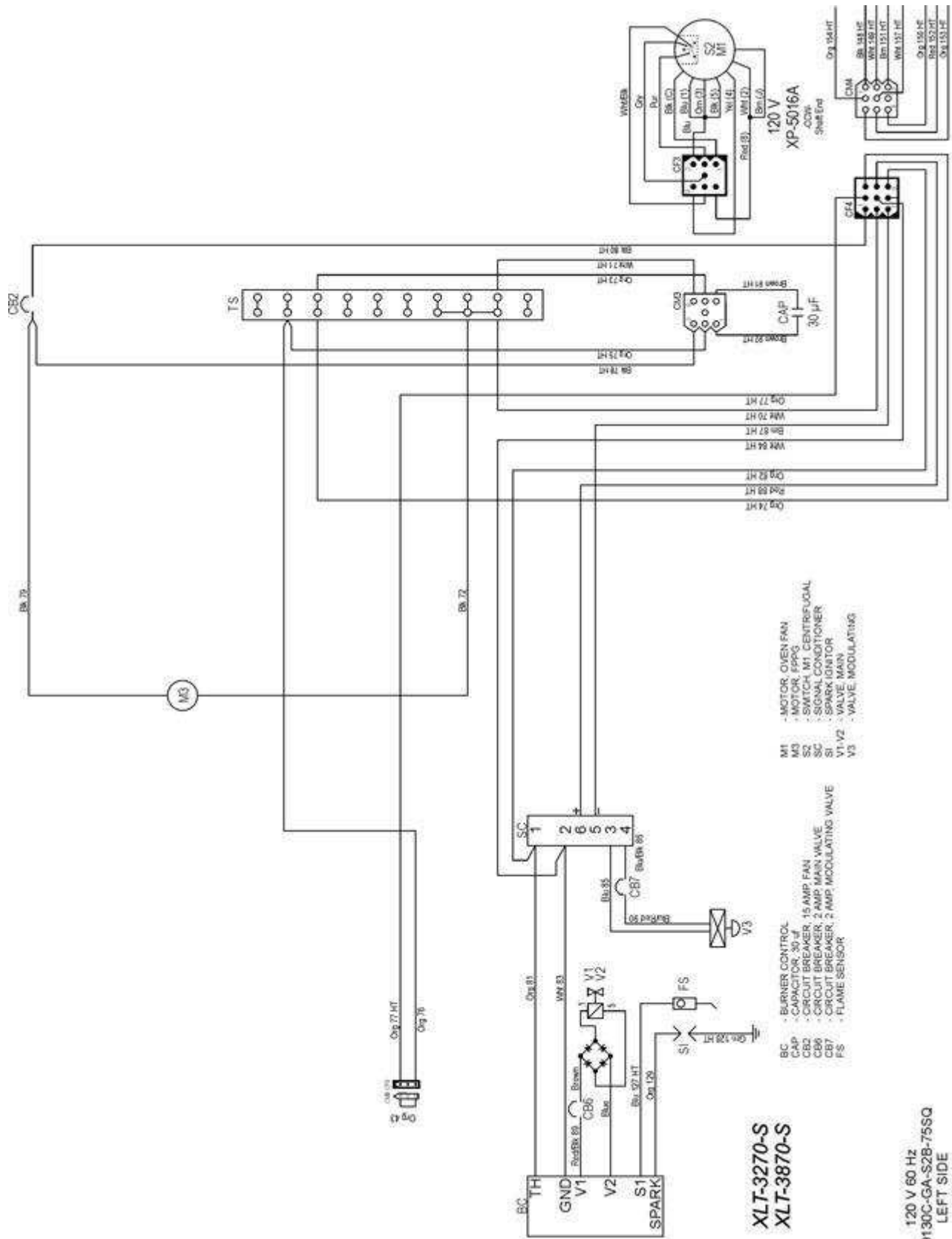

XLT-3270-S
XLT-3870-S

120 V 60 Hz
XD-9130C-GA-S2B-75SQ
LEFT SIDE
06/28/2011

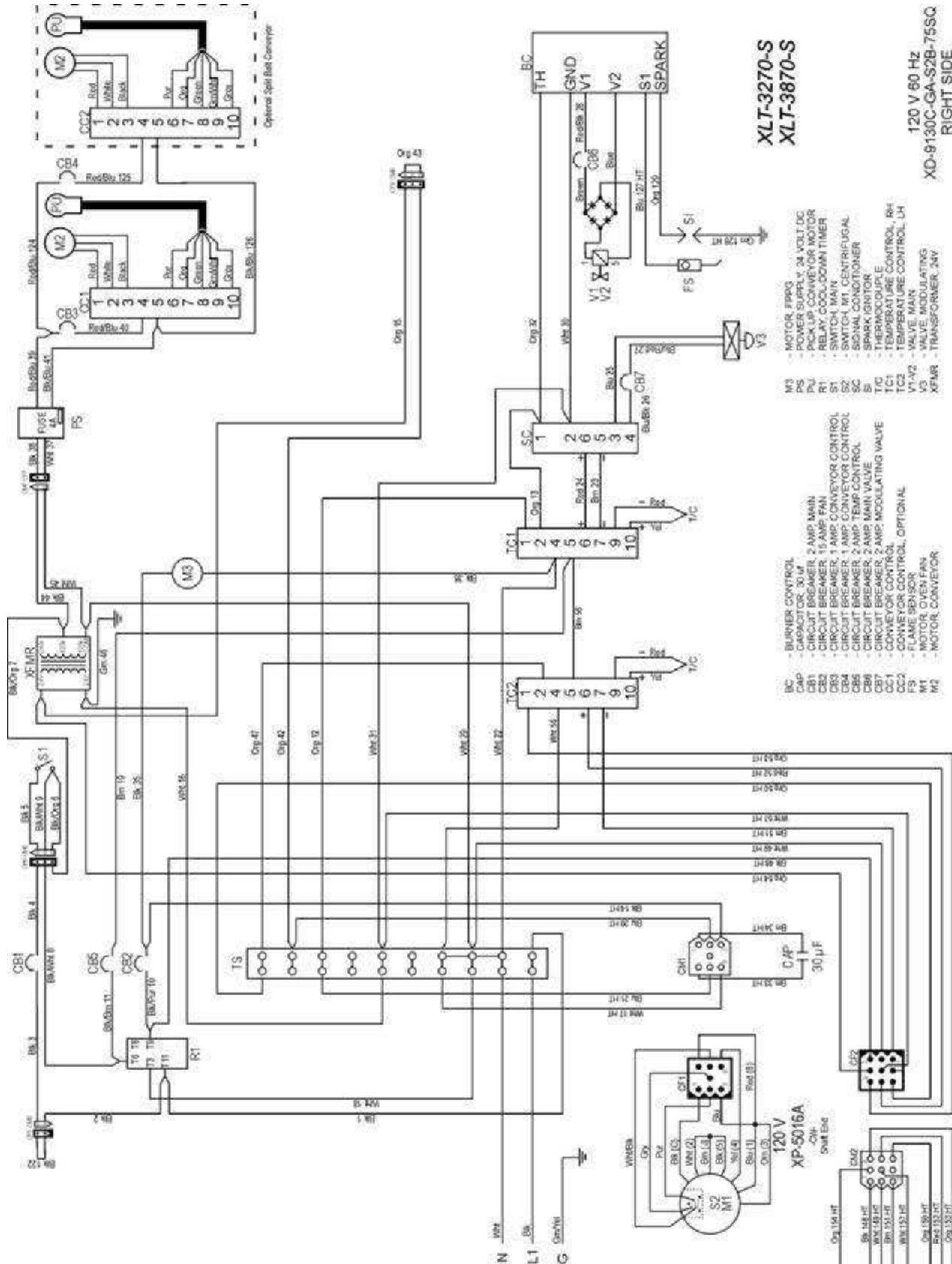

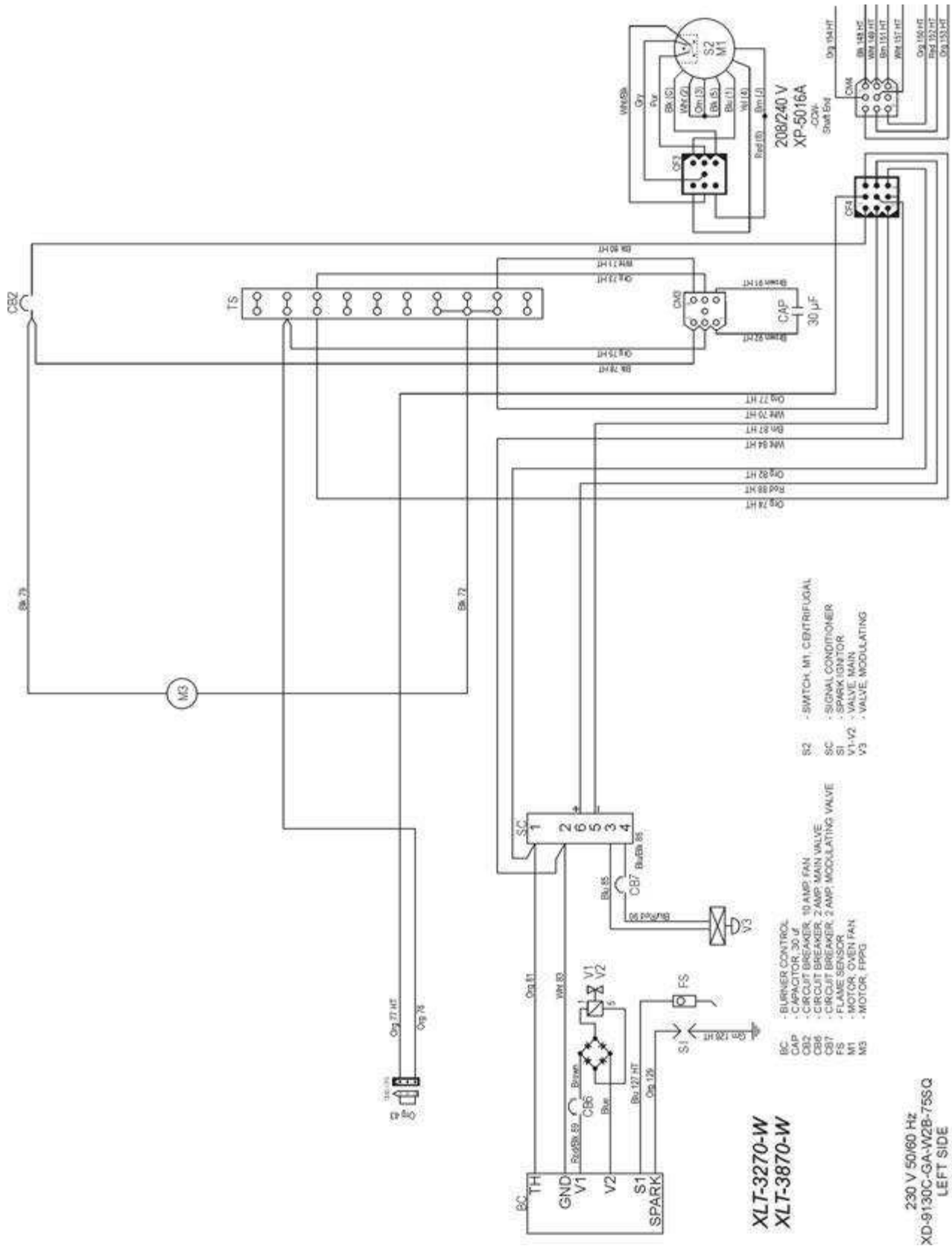

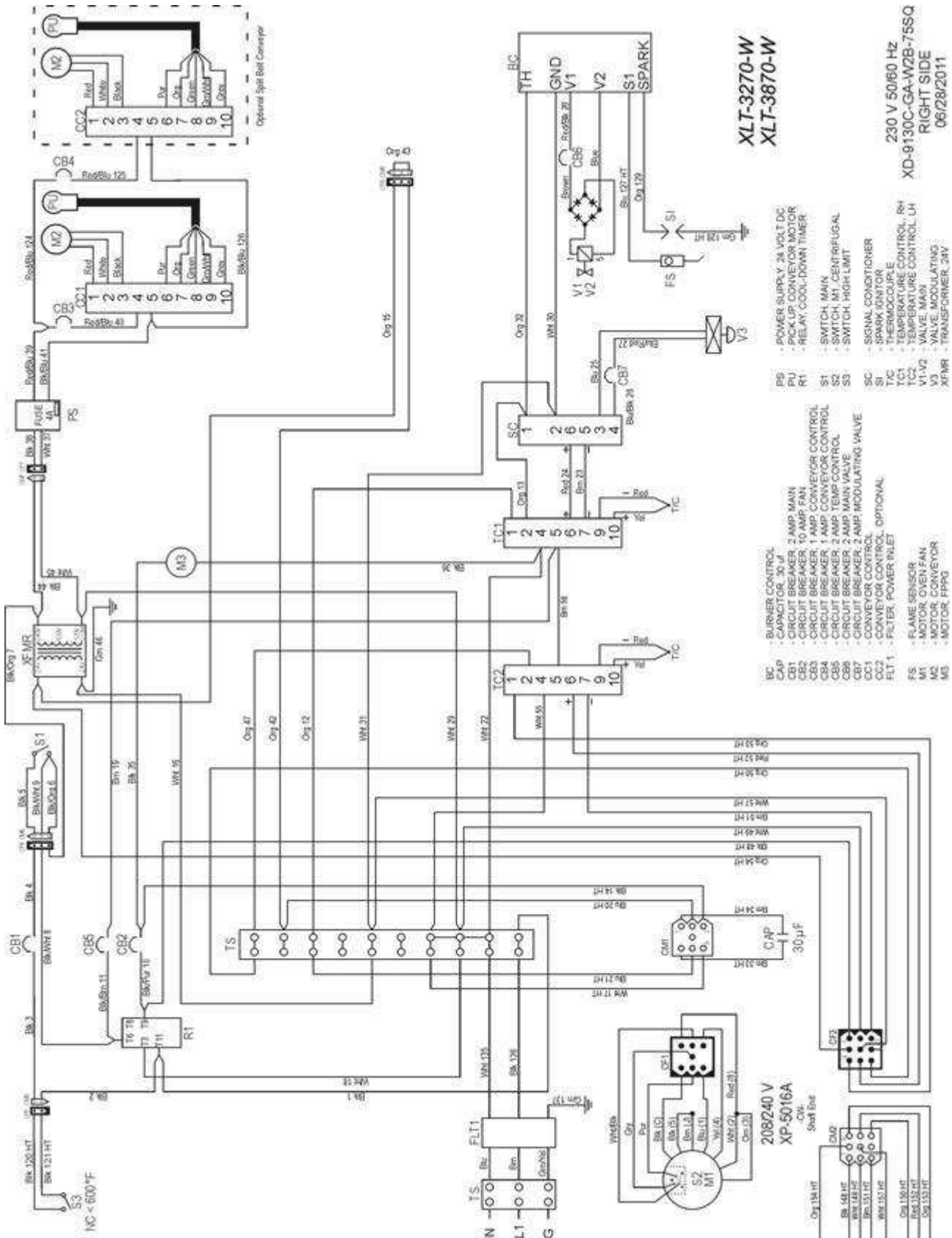

- CB - CIRCUIT BREAKER
- CS - CURRENT SENSOR
- L1 - LAMP 60W BULB
- L2 - LAMP 60W BULB
- L3 - LAMP 60W BULB
- PLUG1 - PLUS SWITCH, TOP OVEN
- PLUG2 - PLUS SWITCH, MIDDLE OVEN
- PLUG3 - PLUS SWITCH, BOTTOM OVEN
- R1 - RELAY DAMPER
- R2 - RELAY DAMPER
- R3 - RELAY DAMPER
- R4 - RELAY DAMPER
- R5 - RELAY EXHAUST FAN
- R6 - RELAY EXHAUST FAN
- R7 - RELAY EXHAUST FAN
- R8 - RELAY FIRE SUPPRESSION
- REC1 - RECEPTACLE POWER, TOP OVEN
- REC2 - RECEPTACLE POWER, MIDDLE OVEN
- REC3 - RECEPTACLE POWER, BOTTOM OVEN
- REC4 - RECEPTACLE SWITCH, TOP OVEN
- REC5 - RECEPTACLE SWITCH, MIDDLE OVEN
- REC6 - RECEPTACLE SWITCH, BOTTOM OVEN
- S1 - 5 SWITCH, LIGHTS
- S2 - 5 SWITCH, TOP OVEN
- S3 - 5 SWITCH, MIDDLE OVEN
- S4 - 5 SWITCH, BOTTOM OVEN
- S5 - 5 SWITCH, MANUAL MODE, KEYS
- S6 - 5 SWITCH, MANUAL MODE, KEYS
- TS1 - TERMINAL STRIP
- TS2 - TERMINAL STRIP
- VFD - VARIABLE FREQUENCY DRIVE CONTROLLER

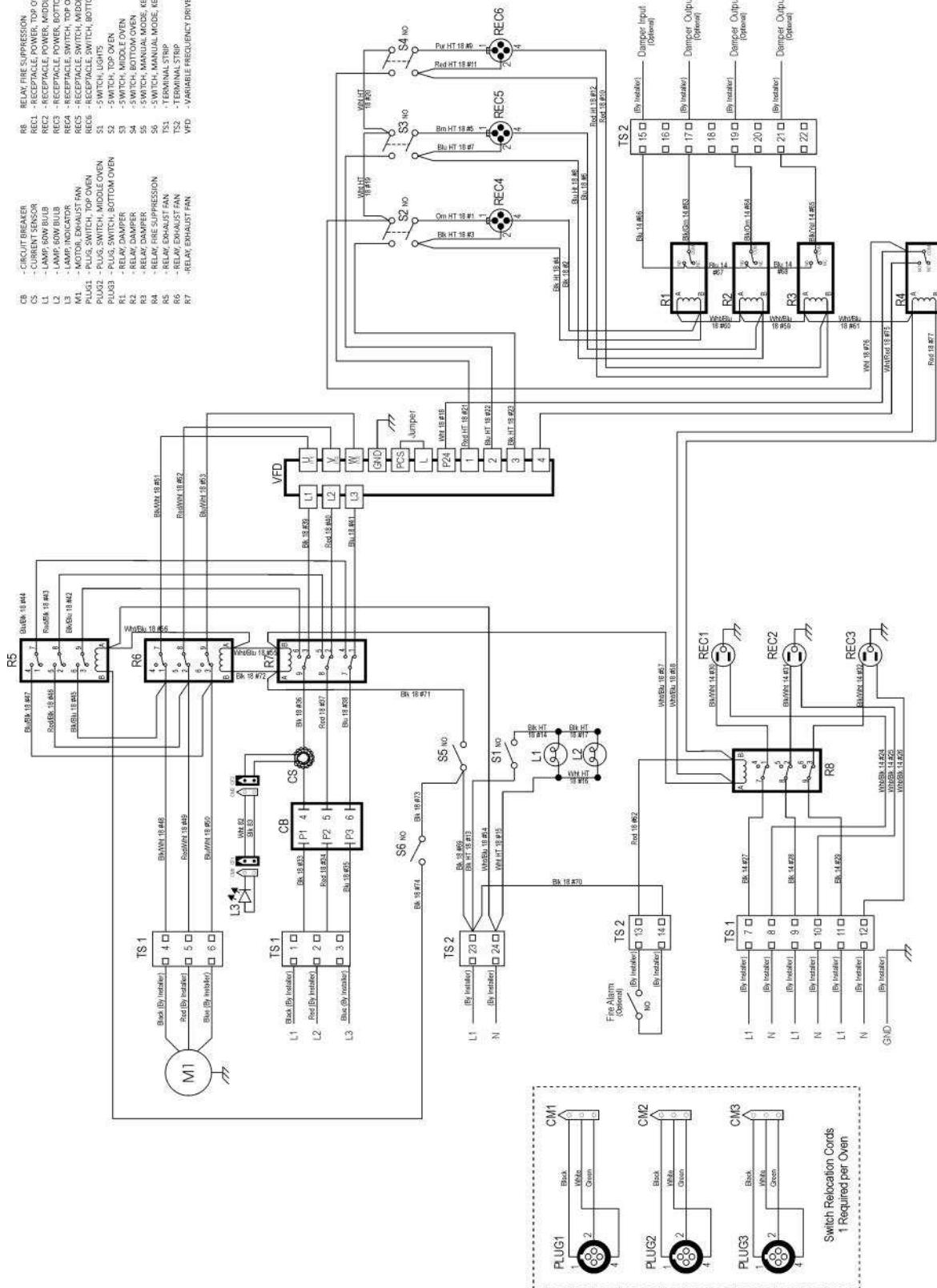

HD-9130B-GAW
03/27/2012

- CB - CIRCUIT BREAKER
- CS - CURRENT SENSOR
- L1 - LAMP, DOWN BULB
- L2 - LAMP, UP BULB
- M1 - MOTOR, EXHAUST FAN
- PLUG1 - PLUG, SWITCH, TOP OVEN
- PLUG2 - PLUG, SWITCH, MIDDLE OVEN
- PLUG3 - PLUG, SWITCH, BOTTOM OVEN
- R1 - RELAY, DAMPER
- R2 - RELAY, DAMPER
- R3 - RELAY, DAMPER
- R4 - RELAY, FIRE SUPPRESSION
- R5 - RELAY, FIRE SUPPRESSION
- R6 - RELAY, FIRE SUPPRESSION
- R7 - RELAY, FIRE SUPPRESSION
- REC1 - RECEPTACLE, POWER, TOP OVEN
- REC2 - RECEPTACLE, POWER, MIDDLE OVEN
- REC3 - RECEPTACLE, POWER, BOTTOM OVEN
- REC4 - RECEPTACLE, SWITCH, MIDDLE OVEN
- REC5 - RECEPTACLE, SWITCH, BOTTOM OVEN
- REC6 - RECEPTACLE, SWITCH, MIDDLE OVEN
- S1 - SWITCH, LIGHTS
- S2 - SWITCH, TOP OVEN
- S3 - SWITCH, MIDDLE OVEN
- S4 - SWITCH, BOTTOM OVEN
- TS1 - THERMAL STRIP
- TS2 - THERMAL STRIP
- VFD - VARIABLE FREQUENCY DRIVE CONTROLLER
- XPMR - TRANSFORMER, 24 VOLT

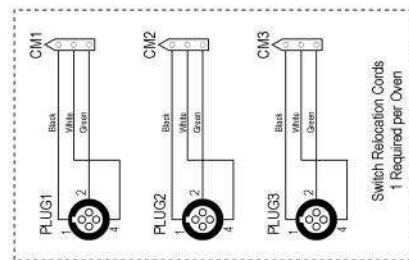
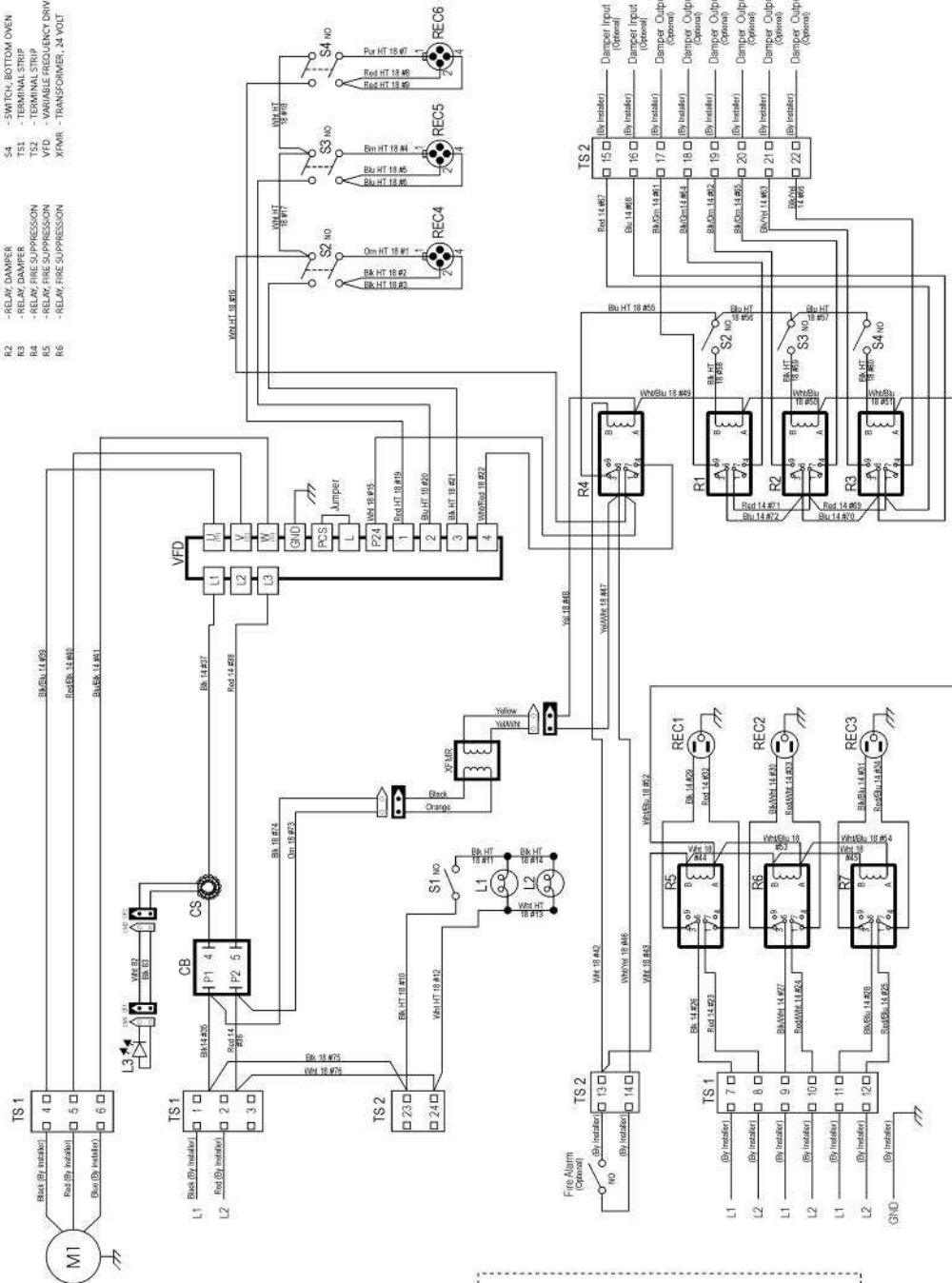

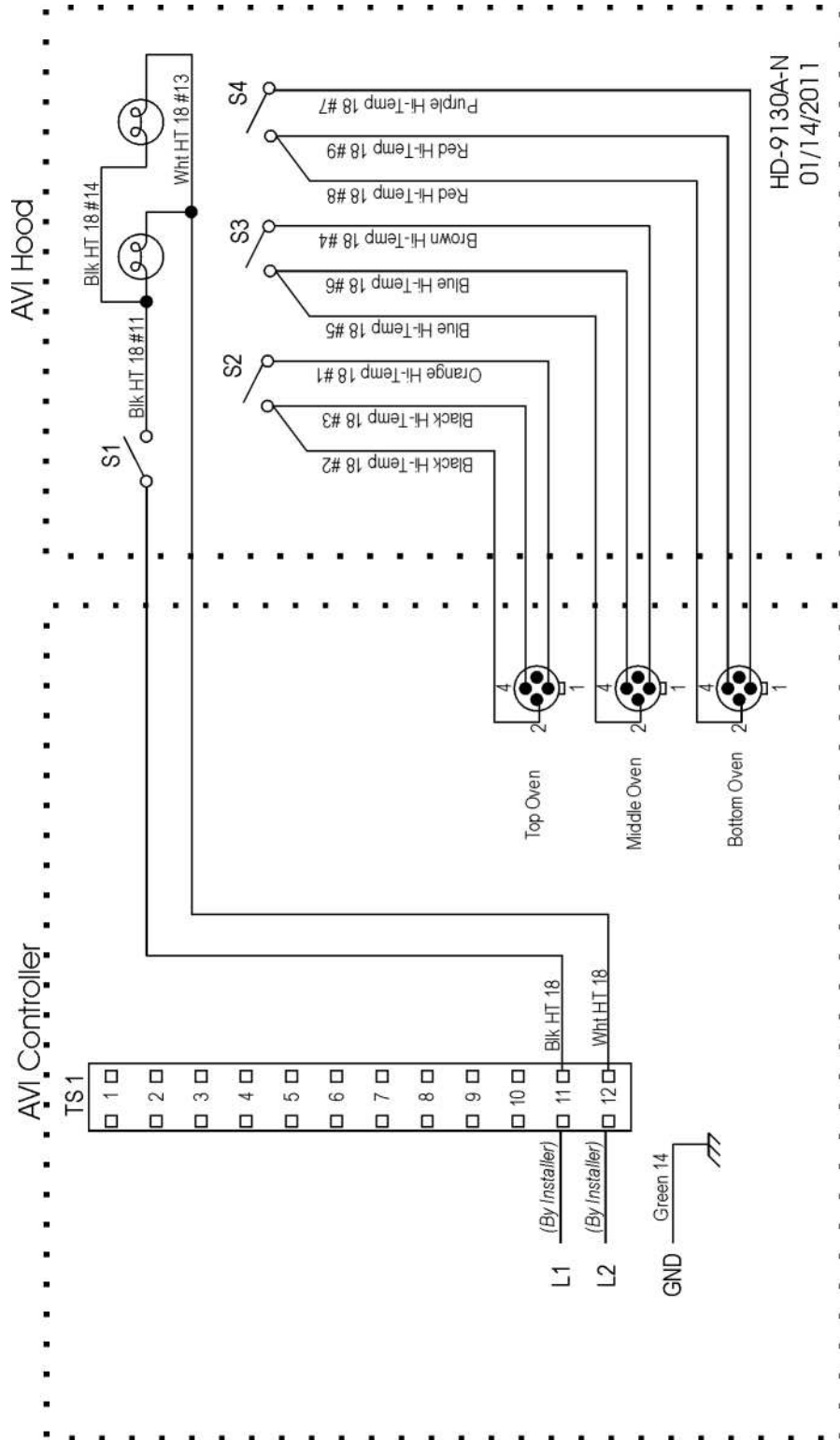

Product Certifications and Applicable Codes**Standard XLT Oven Certifications ¹:****XLT Gas Ovens:**

1. ANSI Z8311-2006/CSA 1.8-2006 Standard for Gas Food Service Equipment
2. ANSI /NSF 4-2006e Sanitation for Commercial Cooking Rethermillization & Powered Hot Food Holding & Transportation Equipment

XLT Electric Ovens:

1. ANSI/UL197-CSA C22.2 Commercial Electric Appliances
2. ANSI /NSF 4-2006e Sanitation for Commercial Cooking Rethermillization & Powered Hot Food Holding & Transportation Equipment

World XLT Oven Certifications¹ :**XLT Gas Ovens:**

1. EN 60335-2-42:2003 + A1:2008, used in conjunction with EN 60335-1:2002, Safety of Household Appliances and Similar Electrical Appliances
2. EN 60335 A11, A1:2004 + A12, A2:2006 + A1/C1:2007 + A13:2008 Low Voltage Directive (LVD)
3. EN 55014-1:2006 EN 61000-3-2:2006, EN 61000-3-3:1995 +A1:2001 +A2:2006, Electromagnetic Compatibility. (EMC)
4. EN 55014-2:1997 +A1:2001, Conducted Emissions, Surge Immunity
5. BS EN 203-1:2005+A1:2008, Standard for Safety of Gas Heated Catering Equipment
6. BS EN 203-2-1: 2005, Standard for Gas Heated Catering Equipment
7. 90/396/EEC. Gas Appliance Directive (GAD)

XLT Electric Ovens:

1. EN 60335-2-42:2003 Safety of Household Appliances and Similar Electrical Appliances
2. EN 60335-1:2002 +A11, A1:2004 + A12, A2:2006 + A1/C1:2007 + A13:2008) Low Voltage Directive (LVD)
3. EN 6100-6-5 Electromagnetic Compatibility (EMC)
4. EN 55014-2:1997 +A1:2001, Conducted Emissions, Surge Immunity
5. EN 6100-6-1 EMC Immunity for residential, commercial & light industrial

Product Certifications and Applicable Codes - Continued

6. EN 5504-1 EMC house hold appliance electric tools & similar appliances
7. EN 6100-3-3 +A1+A2 Voltage fluctuation

Standard & World AVI Hood Certifications ¹:

1. UL 710 Standard for Safety Exhaust Hoods for Commercial Cooking
2. ANSI/NSF 2-2009 Sanitation Food Equipment
3. ULC-S646, Standard for Exhaust Hoods and Related Controls for Commercial and Institutional Kitchens

Australian XLT Oven Certifications ²:**XLT Gas Ovens: (certificate 7373)**

1. AS 4563-2004 Commercial Catering Gas Equipment
2. AS/NZS 3350.1:2002 Safety of Household & Similar Electrical Appliances.

¹ The noted certifications for XLT ovens and AVI Hood are performed and documented by Intertek Testing Services NA Inc. 165 Main Street, Cortland, NY 13045.

Intertek is a nationally and internationally certified testing and accreditation agency.

Oven Initial Start-up Checklist - Remove & Return to XLT Ovens

<p>Date of installation: _____</p> <p>Installed by: <input type="checkbox"/> XLT installer: _____ <input type="checkbox"/> Other: _____ Company: _____</p>	<p>Oven Size: <input type="checkbox"/> 1832 <input type="checkbox"/> 1855 <input type="checkbox"/> 2440 <input type="checkbox"/> 3240 <input type="checkbox"/> 3255 <input type="checkbox"/> 3270 <input type="checkbox"/> 3855 <input type="checkbox"/> 3870</p> <p>Heat Source: <input type="checkbox"/> Natural Gas <input type="checkbox"/> LP <input type="checkbox"/> Electric</p>
<p>Facility Information</p> <p>Store Name: _____ Address: _____ City: _____ State: _____ Zip: _____ Phone #: _____ E-mail: _____ Contact Person: _____</p> <p><input type="checkbox"/> Freestanding <input type="checkbox"/> Strip Mall <input type="checkbox"/> New construction <input type="checkbox"/> Existing location <input type="checkbox"/> Remodel</p> <p>Oven Location: <input type="checkbox"/> Against wall <input type="checkbox"/> In corner <input type="checkbox"/> Island</p> <p>I&O Manual presented to store operator: <input type="checkbox"/> Yes <input type="checkbox"/> No</p> <p>Utilities present at installation: <input type="checkbox"/> Electric <input type="checkbox"/> Gas</p> <p>On-Site dough prep: <input type="checkbox"/> Yes <input type="checkbox"/> No</p> <p>Air-born contaminates: <input type="checkbox"/> Flour <input type="checkbox"/> Cornmeal <input type="checkbox"/> Grease Other: _____</p> <p>HVAC/Contractor Contact: _____ Address: _____ City: _____ State: _____ Zip: _____ Phone #: _____ Cell: _____ E-mail: _____</p> <p>Restraint Cable installed on bottom oven: <input type="checkbox"/> Yes <input type="checkbox"/> No</p> <p>Customer or store operator shown how to disassemble and clean ovens and hood: <input type="checkbox"/> Yes <input type="checkbox"/> No</p> <p>Test cook performed: <input type="checkbox"/> Yes <input type="checkbox"/> No</p> <p>Ovens ran for 30 min: <input type="checkbox"/> Yes <input type="checkbox"/> No</p> <p>All features explained: <input type="checkbox"/> Yes <input type="checkbox"/> No</p> <p>Damage to ovens or hood during shipment or installation: _____</p>	<p>Electrical</p> <p>Electrical utilities accessible: <input type="checkbox"/> Yes <input type="checkbox"/> No</p> <p>Separate electrical circuit per oven: <input type="checkbox"/> Yes <input type="checkbox"/> No</p> <p>Electrical Supply (per oven): _____</p> <p>Gas Ovens Only</p> <p>Inlet Pressures: Static: _____ "WC Dynamic: _____ "WC</p> <p>Gas Line Size: _____ Teflon Tape: <input type="checkbox"/> Yes <input type="checkbox"/> No</p> <p>List all gas appliances in store (with gas requirements)</p> <p>Oven #1: _____ Btu Oven #2: _____ Btu Oven #3: _____ Btu Water Heater: _____ Btu Furnace: _____ Btu Other: _____ Btu</p> <p>Total gas requirements for store: _____ Btu Regulator Capacity: _____ Btu Meter Capacity: _____ Btu</p> <p>Shut off valve accessible after installation: <input type="checkbox"/> Yes <input type="checkbox"/> No</p> <p>One shut off valve per oven: <input type="checkbox"/> Yes <input type="checkbox"/> No</p> <p>Drip Leg installed: <input type="checkbox"/> Yes <input type="checkbox"/> No</p> <p>Ventilation</p> <p>Hood manufacturer <input type="checkbox"/> AVI <input type="checkbox"/> Other (specify) _____</p> <p>Interlock system for non-AVI hood: <input type="checkbox"/> Yes <input type="checkbox"/> No</p> <p>Air balance test performed: <input type="checkbox"/> Yes <input type="checkbox"/> No</p>

Customer Signature: _____ Date: _____

Return to: XLT Ovens
PO Box 9090

Oven Initial Start-up Checklist - Remove & Return to XLT Ovens

Top Oven	<input type="checkbox"/> N/A
Model #: _____	_____
Serial #: _____	_____
<input type="checkbox"/> Thin Crust <input type="checkbox"/> Thick Crust <input type="checkbox"/> Pan <input type="checkbox"/> Screen	
Other Product: _____	_____
Front Belt Speed: _____min _____sec	_____
Back Belt Speed: _____min _____sec	<input type="checkbox"/> N/A
Proper Belt Tension: <input type="checkbox"/> Yes <input type="checkbox"/> No	
Conveyor Belt Direction: <input type="checkbox"/> L to R <input type="checkbox"/> R to L	
Set Point Temp: Left _____ Right _____	
Fingers in proper location: <input type="checkbox"/> Yes <input type="checkbox"/> No	
Fire Suppression Installed: <input type="checkbox"/> Yes <input type="checkbox"/> No	
_____ GAS OVENS ONLY _____	
Right Burner: <input type="checkbox"/> Square <input type="checkbox"/> Round	
Primary Shutter Setting: _____	
Secondary Shutter Setting: _____	
Low flame after temperature drop: <input type="checkbox"/> Yes <input type="checkbox"/> No	
Was Combination Valve adjusted: <input type="checkbox"/> Yes <input type="checkbox"/> No	
High Bias: _____ Low Bias: _____	
Left Burner: <input type="checkbox"/> N/A	
Primary Shutter Setting: _____	
Secondary Shutter Setting: _____	
Low flame after temperature drop: <input type="checkbox"/> Yes <input type="checkbox"/> No	

Middle Oven	<input type="checkbox"/> N/A
Model #: _____	_____
Serial #: _____	_____
<input type="checkbox"/> Thin Crust <input type="checkbox"/> Thick Crust <input type="checkbox"/> Pan <input type="checkbox"/> Screen	
Other Product: _____	_____
Front Belt Speed: _____min _____sec	_____
Back Belt Speed: _____min _____sec	<input type="checkbox"/> N/A
Proper Belt Tension: <input type="checkbox"/> Yes <input type="checkbox"/> No	
Conveyor Belt Direction: <input type="checkbox"/> L to R <input type="checkbox"/> R to L	
Set Point Temp: Left _____ Right _____	
Fingers in proper location: <input type="checkbox"/> Yes <input type="checkbox"/> No	
Fire Suppression Installed: <input type="checkbox"/> Yes <input type="checkbox"/> No	
_____ GAS OVENS ONLY _____	
Right Burner: <input type="checkbox"/> Square <input type="checkbox"/> Round	
Primary Shutter Setting: _____	
Secondary Shutter Setting: _____	
Low flame after temperature drop: <input type="checkbox"/> Yes <input type="checkbox"/> No	
Was Combination Valve adjusted: <input type="checkbox"/> Yes <input type="checkbox"/> No	
High Bias: _____ Low Bias: _____	
Left Burner: <input type="checkbox"/> N/A	
Primary Shutter Setting: _____	
Secondary Shutter Setting: _____	
Low flame after temperature drop: <input type="checkbox"/> Yes <input type="checkbox"/> No	

Bottom Oven	<input type="checkbox"/> N/A
Model #: _____	_____
Serial #: _____	_____
<input type="checkbox"/> Thin Crust <input type="checkbox"/> Thick Crust <input type="checkbox"/> Pan <input type="checkbox"/> Screen	
Other Product: _____	_____
Front Belt Speed: _____min _____sec	_____
Back Belt Speed: _____min _____sec	<input type="checkbox"/> N/A
Proper Belt Tension: <input type="checkbox"/> Yes <input type="checkbox"/> No	
Conveyor Belt Direction: <input type="checkbox"/> L to R <input type="checkbox"/> R to L	
Set Point Temp: Left _____ Right _____	
Fingers in proper location: <input type="checkbox"/> Yes <input type="checkbox"/> No	
Fire Suppression Installed: <input type="checkbox"/> Yes <input type="checkbox"/> No	
_____ GAS OVENS ONLY _____	
Right Burner: <input type="checkbox"/> Square <input type="checkbox"/> Round	
Primary Shutter Setting: _____	
Secondary Shutter Setting: _____	
Low flame after temperature drop: <input type="checkbox"/> Yes <input type="checkbox"/> No	
Was Combination Valve adjusted: <input type="checkbox"/> Yes <input type="checkbox"/> No	
High Bias: _____ Low Bias: _____	
Left Burner: <input type="checkbox"/> N/A	
Primary Shutter Setting: _____	
Secondary Shutter Setting: _____	
Low flame after temperature drop: <input type="checkbox"/> Yes <input type="checkbox"/> No	

Hood Initial Start-up Checklist - Remove & Return to XLT Ovens

Model #: _____

Serial #: _____

VFD power supplied:

_____ Volts _____ Amps

_____ Hz _____ Phase

Height from bottom of hood to finished floor:

_____ Feet _____ Inches

Length of duct run (from top of hood to fan):

_____ Feet _____ Inches

Number of bends in duct run: _____ 45° _____ 90°

Rating of exhaust fan: _____ CFM

Hood hung prior to oven installation: Yes No

Hood hung to local codes: Yes No

Switches face front of ovens: Yes No

VFD box cover replaced after installation: Yes No

All shroud panels properly installed: Yes No

Grease filters properly installed: Yes No

Grease trays properly installed: Yes No

Crumb trays easily removable: Yes No

Oven power cords connected to VFD box: Yes No

Electric Oven N/A

Oven switch cords connected to VFD box: Yes No

Lights operate with switch: Yes No

Light globes installed over bulbs: Yes No

Exhaust fan purchased from XLT: Yes No

Exhaust fan operates with hood switches: Yes No

Correct fan rotation: Yes No

Fire suppression relay in VFD box utilized: Yes No

VFD properly programmed: Yes No

Valance Kit: Yes No

Duct Valance Kit: Yes No

Customer Signature: _____ Date: _____

Notes: _____

Return with Oven Initial Start-up form to: XLT Ovens
PO Box 9090
Wichita, KS 67277
FAX: 316-943-2769

XLT Ovens
PO Box 9090
Wichita, Kansas 67277

US: 888-443-2751 FAX: 316-943-2769 INTL: 316-943-2751 WEB: www.xltovens.com