



Leica EZ5

User manual

Contents

| | |
|------------------------------------------------------------------------|----|
| Safety concept | |
| Safety concept | 6 |
| Symbols | 8 |
| Description | 9 |
| | |
| Installation | |
| System diagram | 10 |
| Installing the basic equipment | 12 |
| Assembly | 13 |
| Assembly | 15 |
| | |
| Operation | |
| Operation | 17 |
| | |
| Special instructions | |
| What to do, if | 25 |
| Maintenance | 26 |
| Calculating total magnification and the object field diameter | 29 |
| Optical data of the Leica EZ5 | 30 |
| Dimensions of the Leica EZ5 | 31 |
| Leica Microsystems around the world | 32 |

Dear User,

Thank you for your confidence in our product. We wish you much enjoyment and success with your new EZ5 stereomicroscope from Leica Microsystems.

The new Leica EZ5 is an exciting addition to the extensive product range offered by our Swiss Stereomicroscopy business unit. The Leica EZ5 has been designed specifically with a view to OEM applications. In order to safeguard against ESD, the entire stereomicroscope – including the optional cold light source and the stand – has been constructed with antistatic materials.

While developing the Leica EZ5, we took the greatest care to ensure that its operation would be simple and self-explanatory. Even so, please take a little time to read the accompanying operating instructions. This is the best way to familiarize yourself with all the features of your stereomicroscope and use it to its full advantage. And if you have any questions, please contact your Leica representative or Leica Microsystems (Switzerland) Ltd., Heerbrugg, Switzerland. We are gladly at your service. CUSTOMER SERVICE is a big thing with us – before and after the sale (see page 36).

Leica Microsystems (Switzerland) Ltd.
Stereo & Macroscopy Systems
www.stereomicroscopy.com

Safety concept

General notes Read the operating instructions and safety notes before commissioning.

Proper use The Leica EZ5 is a precision optical instrument designed to facilitate visual examination of objects, object details or specimens in the fields of technology and science by magnifying them. The equipment is supported by a full range of stands, illumination systems and accessories.

- Non-intended use**
- Using the instrument in any way other than that described in these instructions may result in personal injury or damage to property.
 - The Leica EZ5 must not be used in examinations of or operations on the eye.
 - Optical systems and mechanical parts must never be unscrewed from each other unless expressly indicated in the instructions.

- Place of use**
- The Leica EZ5 is primarily intended for use in enclosed premises.
 - If it is used outdoors, the Leica EZ5 must be protected from dust and moisture. Electrically powered illumination systems and stands produced by Leica Microsystems must not be used outdoors.

Integration in a third-party product



When installing Leica products into third-party products, note the following: The manufacturer of the complete system or its dealer is responsible for following all applicable safety instructions, laws and guidelines.

- Use in clean rooms** The Leica EZ5 is suitable for use in clean rooms and can be prepared for such use as described on page 27. Please observe the following rules:
- Never use any procedure other than the one described in these operating instructions to clean the Leica EZ5 and its accessories. Do not use unsuitable cleaning agents, chemicals or equipment. Never use chemicals to clean colored surfaces and accessories with rubberized parts. This may damage surfaces and abraded particles may contaminate preparations.
 - If a user uses chemicals to clean any Leica instrument without our written approval, he does so at his own risk.
 - We will be glad to offer special solutions upon request that are sufficient for most circumstances. Some products can be modified, or we can offer different accessories for use in clean rooms.
- Servicing** Only Leica Microsystems-trained service technicians are permitted to carry out repairs. Only original Leica Microsystems spare parts may be used.
- Responsibilities of the person(s) in charge of instrument**
- Ensure that all staff who are responsible for operating the equipment have read and understood these instructions, particularly the safety notes.
 - Ensure that the Leica EZ5 is operated, maintained and repaired only by authorized and trained staff.

Safety concept



Workplaces equipped with stereomicroscopes facilitate and improve the viewing task, but they also impose high demands on the eyes and holding muscles of the user. Long periods of uninterrupted activity may cause asthenopic complaints and injury to the musculoskeletal system. Appropriate measures should be adopted to reduce physical stress:

- optimal arrangement of workplace, work assignments and work flow (changing tasks frequently).
- thorough training of the personnel, giving consideration to ergonomic and organization aspects.

The ergonomic optics concept and the design of the Leica EZ5 aim to limit the strain on the user to the lowest possible level.



Direct contact with eyepieces is a potential transmission method for bacterial and viral infections of the eye. Users should be made aware of the potential risk of infection. This risk can be minimized by using personal eyepieces or removable eyecups (see page 19).

Eyecups can be purchased separately. For more information, contact your Leica partner.

Liquids Exercise particular care when handling liquids.
The instrument may be damaged by spilled liquids.

Legal requirements Adhere to general and local regulations relating to accident prevention and environmental protection.

Disposal The products described here must be disposed off in accordance with applicable local laws and regulations.

Symbols

You will see these symbols in the operating instructions



Safety instructions

This symbol indicates especially important information that must be read and complied with. Failure to follow these instructions may endanger personnel!



Failure to follow these instructions may impair the system's performance or damage the instrument.



Important information

This symbol indicates additional information or explanations that intend to provide clarity.

Action

- ▶ This symbol refers to actions described in the text that are to be carried out.

Explanatory notes

- This symbol indicates additional notes and explanations provided in the text.

Description

Greenough based optical system The optical system of the Leica EZ5 consists of two beam paths converging at 10°. The lens pairs of each optical path are positioned close together, so the stereomicroscope can be of very "slender" design, especially towards the base of the instrument. The advantages of this design are that it has a small space requirement for use on bonders and in machine applications, unobstructed access to specimens, plenty of space for tools and a completely clear view of the object field.

The Greenough system enables cost-effective correction of aberrations such as chromasia, image field curvature, and distortion with minimal effort. The new Leica EZ5 uses the most corrected area of each lens for image production. This provides superior optical performance with large, level and undistorted fields of view and chromatically optimized, high-contrast images.

ESD protection The Leica EZ5 together with its cold light source and stand is made from highly conductive materials with area resistivity of 2×10^{11} Ohm/square. Charges are cut from 1000V to 100V in less than 2 seconds.

Leica EZ5 with swing-arm system



System diagram

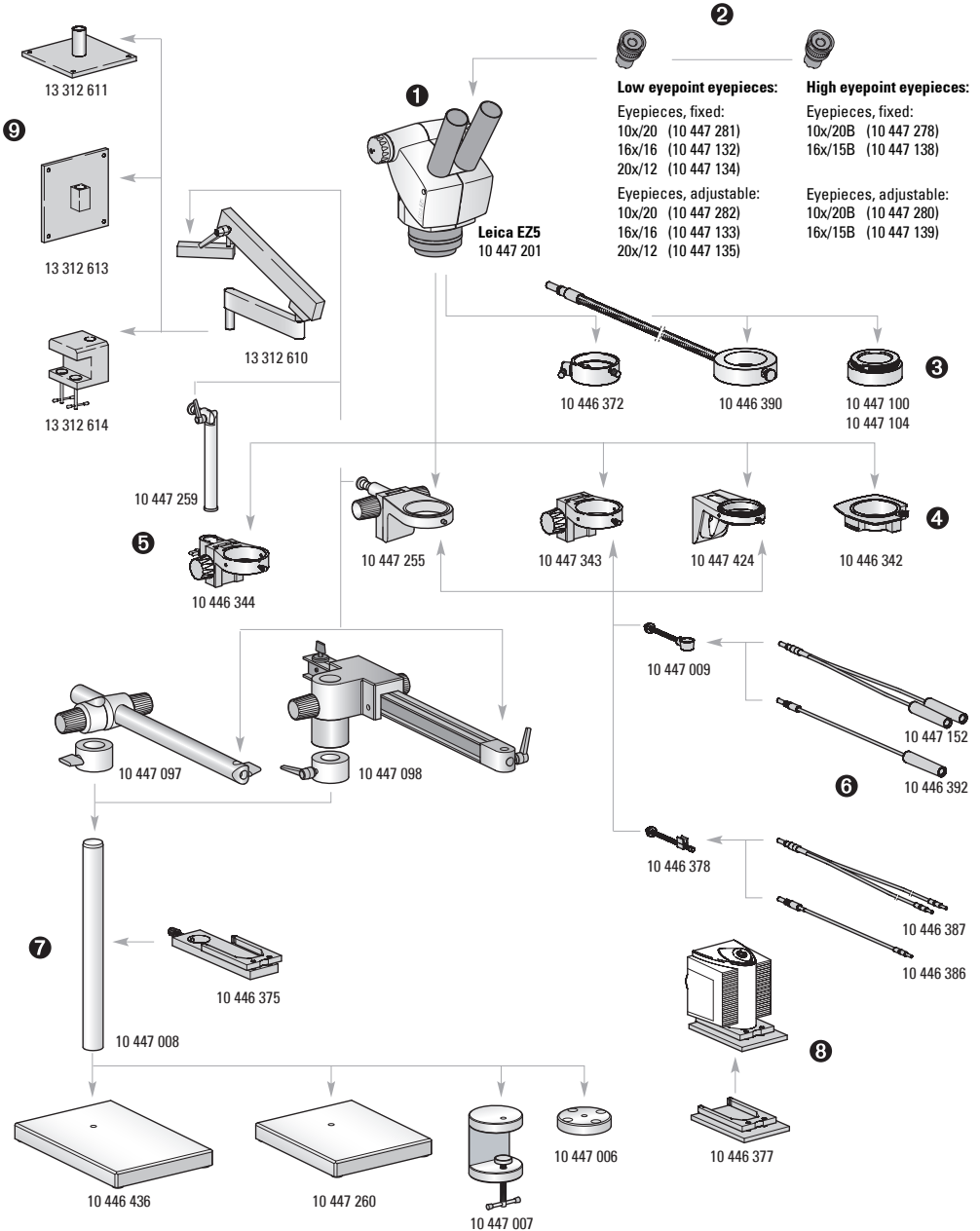

- 1 EZ5 optics carrier
- 2 Eyepieces
- 3 Objectives
- 4 Carriers/focus arms
- 5 Focusing columns
- 6 L2 waveguide
- 7 Swing-arm stands
- 8 Leica L2 cold light source
- 9 Flex-arm accessories

For detailed descriptions, please refer to brochure M1-188-4en.

Installing the basic equipment

- The components**
- 1 Eyepieces, fixed and/or adjustable
 - 2 Optics carrier, Leica EZ5
 - 3 Additional objective, optional
 - 4 Focusing column with microscope carrier

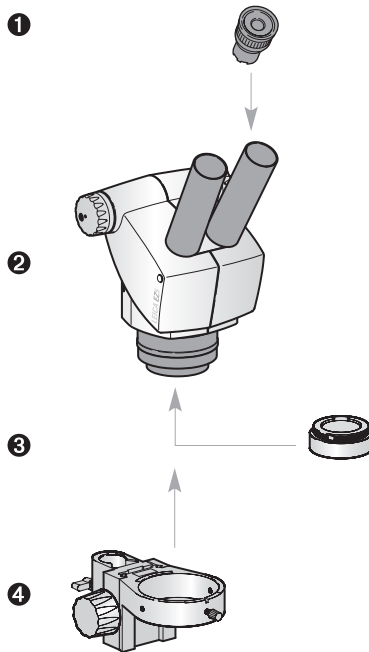

Assembly

- Optics carrier**
→ **Stand**
- ▶ Insert the optics carrier gently in the microscope carrier.
 - ▶ Fix the optics carrier in the desired position with the clamp screw.

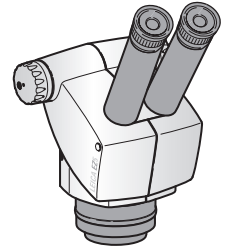

- Additional objective (optional)**
→ **Optics carrier**
- ▶ Screw the selected lens counterclockwise until it is seated firmly in place.

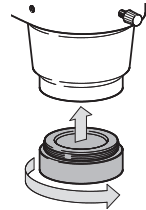

- Protective glass cover (optional)**
- ▶ Screw the protective glass cover firmly onto the thread directly on the Leica EZ5.
This cover cannot be used at the same time as an additional objective.

- Eyepieces**
→ **Tubes**
- ▶ Push eyepieces as far as they will go into the tubes.
 - ▶ Check that they are seated firmly and precisely in place.

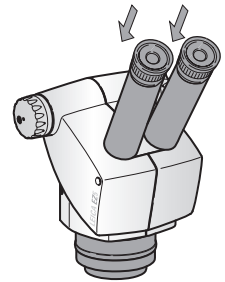

You can use your Leica EZ5 together with a fixed or adjustable eyepiece. For models in which a graticule is included in an eyepiece for measurement or photography, two eyepieces are necessary.

Soft eyecups Eyepieces are supplied with soft eyecups, which you can attach to the eyepieces in order to ...

- prevent eye infections if several users are working with the same instrument (see page 6).
- protect your eyeglasses from scratching.

**Cold light source
Leica L2 → Stand** The Leica L2 cold light source and its glass fiber waveguides is the preferred illumination system for the Leica EZ5 stereomicroscope. A number of matching adapters are available for connecting the Leica L2 cold light source to various stereomicroscope stands and for stand-alone operation.

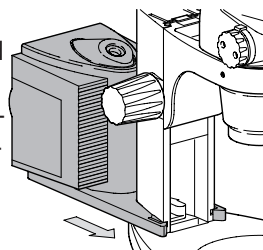

Illumination systems For detailed information about installation and use, please refer to the operating instructions for the Leica L2.

For more sophisticated requirements, e.g. photography, we offer a range of high-performance transmitted-light stands and low-voltage illumination systems. Ask your Leica sales representative for more details.

Assembly

Graticule The following graticules and stage micrometers for calibrating may be ordered:
→ **Adjustable eyepieces**

- Graticule 10mm/0.1mm
- Graticule 5mm/0.1mm
- Graticule 5mm/0.05mm
- Graticule 100 Div./0.002"
- Graticule 100 Div./0.001"
- Graticule 150 Div./0.0005"
- Crosshairs
- Stage micrometer 50mm, 0.1/ 0.01mm graduation
- Stage micrometer 1", 0.001" graduation

A 10× focusing and framing graticule is available for photographic applications.



For models in which a graticule is included in an eyepiece for measurement or photography, two eyepieces are necessary.

Graticules can be inserted in the adjustable eyepieces and the eyepieces for eyeglass wearers:

- ▶ Use the stereomicroscope to determine the side on which the scale is inscribed. The scale should not appear reversed.
- ▶ Remove the insert from the bottom of the eyepiece and place it on the bench with the knurled side down.

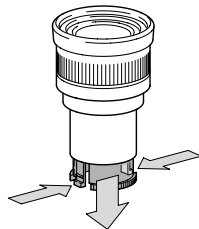

- ▶ Hold the graticule by the edges to avoid leaving fingerprints, and push it into the holder from the side.
- ▶ Replace the insert in the eyepiece and press it firmly into place.
- ▶ Insert the eyepiece in the tube and turn the eyepiece in the tube to align the graticule correctly.

The procedure for taking measurements is described in the "Measuring" operating instructions.

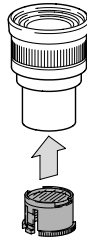
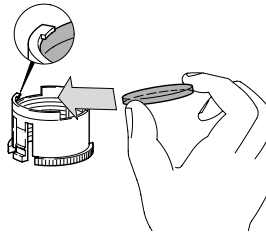

Operation

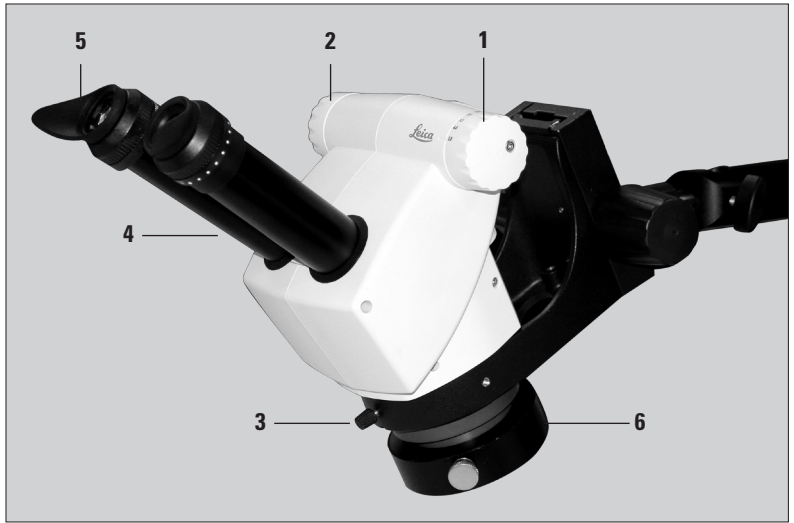

Control elements and functions of the standard equipment

- 1 Magnification changer, right drive knob with magnification scale
- 2 Focusing knob
- 3 Fixing screw secures the optics carrier in the microscope carrier
- 4 Adjustable tubes:
Interpupillary distance adjustable from 55 – 75 mm
- 5 Eyepieces
- 6 Thread for lens / protective glass
(figure shows ring illuminator)

Requirements for working comfortably

- Make sure that your Leica EZ5 is adjusted correctly. You must make all the settings described here precisely in order to be able to take full advantage of its outstanding optical and ergonomic advantages.
- Set your work area up for the best possible conditions. Consider the height of the bench and chair.
- Use the whole seat surface and the backrest.
- Ensure that your lower arms are supported.
- When carrying out other tasks, perform exercises to relax and relieve muscle tension.

The Leica EZ5 with a 60° viewing angle offers optimum viewing height on the inclined stereomicroscope.

Interpupillary distance, exit pupil

The interpupillary distance is adjustable in a range from 55 – 75mm.

The exit pupil is the distance between the eye and the eyepiece. It is

- 12mm for standard eyepieces 10×/20, 16×/16 and 20×/12, fixed and adjustable.
- 22mm for eyepieces 10×/23B and 16×/15B, fixed and adjustable, and also for the wide-field eyepieces for eyeglass wearers, 10×/21B, 16×/14B, 25×/9.5B and 40×/6B.

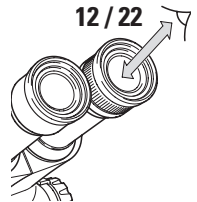

- ▶ Move your eyes slowly towards the eyepieces and push the tubes together or apart with two hands until you see a single, round image field with no shadowing with both eyes.

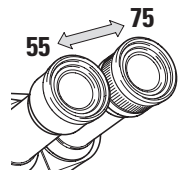

Operation

Eyecups Eyepieces are supplied with detachable eyecups (see also page 8).

If you do not wear eyeglasses and want close contact with the eyecups:

- ▶ Place eyecups on the eyepieces.

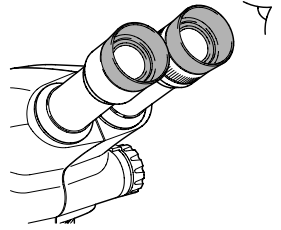

If you wear eyeglasses for work:

- ▶ Fold the eyecups backwards.
- In this way, the eyecups will prevent your eyeglasses from being scratched.

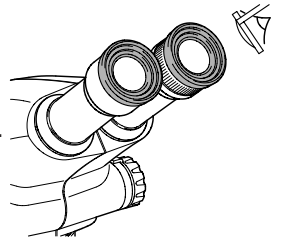

Adjust working distance, focusing = creating a clear image

In order to focus, the operator uses the focusing drive to raise/lower the stereomicroscope until the desired object site is in the focus = working distance of the objective. To see the working distances for the various objectives, please refer to the table on page 30.

The focusing drive can be operated with the right or left hand.

- ▶ Place the object under the objective.
- ▶ Set the lowest magnification.
- You should set the lowest magnification because it is easier to find the desired object site in a large object field.
- ▶ Look into the eyepieces.
- ▶ Use the drive knob to bring the object into focus.

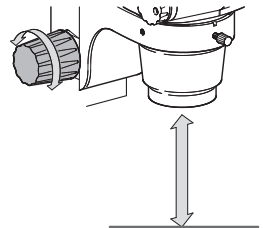

Note: The instruments shown on this page are example illustrations only, and may differ slightly from the actual appearance of the Leica EZ5.

Setting the ease of adjustment of the focusing drive

Is the focus movement too loose or too tight? Does the outfit tend to slide downwards? The force required to adjust the focusing drive can be increased or reduced depending on the weight of the equipment and the user's personal preference:

- ▶ Hold the drive knobs in both hands and turn them towards each other until the desired resistance is obtained when focusing.

Turning optics carrier sideways

The optics carrier can be turned sideways in the microscope carrier if the user wants to work from the side:

- ▶ Loosen the clamping screw.
- ▶ Turn the optics carrier to one side as required.
- ▶ Tighten the clamping screw.

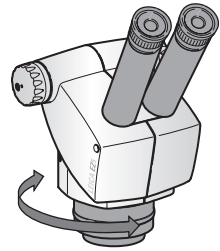

Zoom magnification changer

On the Leica EZ5, the magnification can be changed non-incrementally. The magnification changer can be operated with the right or left hand. A magnification scale has been provided on the right-hand drive knob, and is graduated with values from 1 to 5.

Changing magnification

The table on page 30 shows the magnifications and object field diameters relative to the position magnification changer and the eyepiece/objective combination being used.

- ▶ Look into the eyepieces.
- ▶ Bring the object into focus (page 19)
- ▶ Turn the magnification changer until the desired magnification has been set.

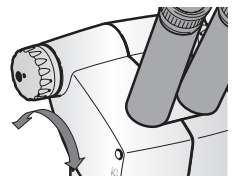

Operation

Setting diopters and parfocality

If you set the diopters on the adjustable eyepiece exactly as described, the image will remain equally sharp from the lowest to the highest magnification. This is referred to as parfocality, and it means that you do not have to adjust the focus when the magnification is changed. You will only have to focus again when you want to view an object site at a higher or lower location. Use this advantage as often possible, it is not available on all stereomicroscopes.

- Diopters can be adjusted from +5 to -5.

Each user needs to make these settings only once.

When a graticule is used, diopters and parfocality are adjusted slightly differently, and this procedure is described in the operating instructions for the graticules (Measuring).

Set the diopter with an adjustable and a fixed eyepiece

Preparatory work

- ▶ Set up the illumination system
- ▶ Adjust the interpupillary distance (page 18).
- ▶ Use the focusing drive to set the working distance approximately (the working distances of the various objectives are listed on page 30).

Focusing a test object

- ▶ Place a flat test object under the objective.
- ▶ Set the lowest magnification.
- ▶ Close the eye over the adjustable eyepiece and look into the fixed eyepiece with the other eye.
- ▶ View the test object and use the focusing drive to bring it into focus.

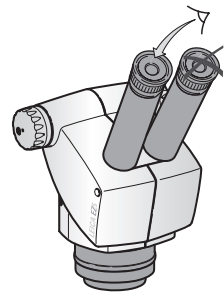

Setting the diopter on the adjustable eyepiece

- ▶ Without looking into the eyepieces, turn the eyelens on the eyepiece as far as it will go in the '+' direction.

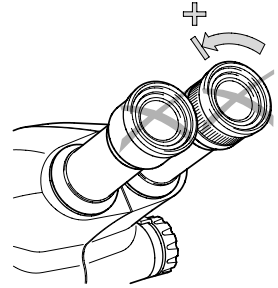

- ▶ Close the eye over the fixed eyepiece and look into the adjustable eyepiece with your other eye.
- ▶ View the test object and slowly turn the eyelens clockwise, towards '-', until your eye sees the object in focus.

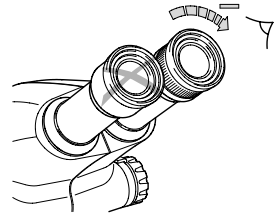

- ▶ Set the highest magnification.
- ▶ View the test object with both eyes and use the focusing drive to optimize the sharpness of the image.

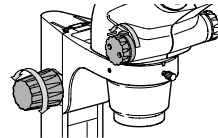

Checking parfocality

Slowly move the magnification changer from the lowest magnification to the highest.

- The sharpness should be constant (parfocal). If this is not the case, repeat this procedure.

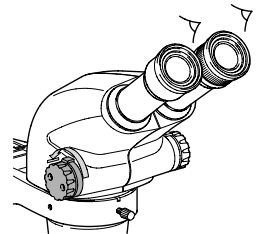

Note: The instruments shown on this page are example illustrations only, and may differ slightly from the actual appearance of the Leica EZ5.

Set the diopter with two adjustable eyepieces

- Preparatory work**
- ▶ Use the focusing drive to set the working distance approximately (the working distances of the various objectives are listed on page 30).
 - ▶ Set up the illumination system.
 - ▶ Adjust the interpupillary distance (page 18).
 - ▶ Set '0' diopters on both eyepieces.
- Focusing on the test object**
- ▶ Place a flat test object under the objective.
 - ▶ Set the lowest magnification.
 - ▶ View the test object through the eyepieces and use the focusing drive to bring the object into focus.
 - ▶ Set the highest magnification.
 - ▶ Use the focusing drive to optimize the sharpness of the image.

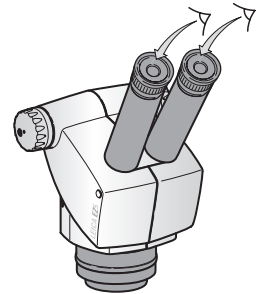

Adjusting diopter settings

- ▶ Set the lowest magnification.
- ▶ Do not look into the eyepieces!
- ▶ Turn the ocular eyelenses counter-clockwise, towards the '+' as far as they will go.

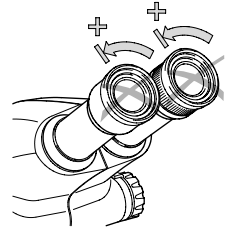

- ▶ Now look into the eyepieces.
- ▶ Close one eye.
- ▶ With the other eye, view the test object and slowly rotate the eyelens clockwise, in the '-' direction until the object appears in focus to that eye.
- ▶ Adjust the diopter for the other eye in the same way.

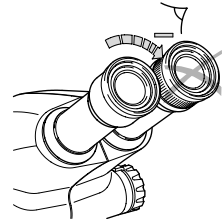

Checking parfocality

- ▶ Select the highest magnification.
- ▶ Look at the object, and gently adjust the focus if necessary.
- ▶ Slowly move the magnification changer from the lowest magnification to the highest.
- The sharpness should be constant for the entire zoom range (parfocal). If this is not the case, repeat this procedure.

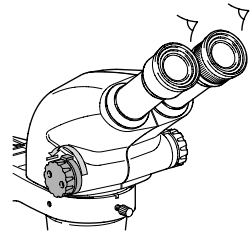

Note: The instruments shown on this page are example illustrations only, and may differ slightly from the actual appearance of the Leica EZ5.

What to do, if ...

There is a shadow on the object field.

- Adjust the interpupillary distance correctly (page 18).

The image does not become sharp.

- Insert the eyepieces correctly (page 13).
- Carry out diopter correction exactly as described in the instructions (page 21).

The focusing drive gradually sinks on its own or is difficult to turn.

- Adjust the ease of movement (page 20).

Maintenance

In the following section, we will describe the proper care of your valuable instrument and provide a few hints on maintenance and cleaning.

Protect your instruments

- From moisture, dust, acids, bases, and caustic substances.

Do not store any chemicals near your instruments.

- From improper treatment.

Optical systems and their mechanical parts must never be separated unless such an operation is explicitly recommended in the instructions.

- From oil and grease.

Do not grease guide surfaces or mechanical parts.

Dust and dirt will affect the quality of your results

- Place the dust cover over your instrument when you are not working with it.
- Protect the tubus openings, tubes without eyepieces, and eyepieces with dust covers.
- Remove dust with a bellows and a soft paintbrush.
- Clean eyepieces and objectives with special optics cleaning cloths and pure alcohol.
- Store accessories in a dust-free environment when they are not in use.

Cleaning plastic parts Several components are made of plastic or are plastic-coated. This makes them comfortable to hold and handle. If these parts are cleaned improperly with unsuitable cleaning agents, the plastic may be damaged. Therefore, please follow these instructions:

- Never clean**
- In an ultrasound device. The plastic may become brittle and over time may crack.
 - With caustic or acetone-based media such as ether substitute.
 - With other solvents, with the exception of ethanol and isopropanol.

- How to clean without damaging the equipment**
- With warm soapy water, then wiping down with distilled water.
 - With ethanol (industrial alcohol) and isopropanol.



If ethanol or isopropanol is used for cleaning, the appropriate safety regulations must be obeyed.

We guarantee the quality of our products

You are working with an extremely high-performance precision instrument. Accordingly, we guarantee the quality of our instruments. This guarantee covers manufacturing and material faults, but not damage that has been caused by negligence or improper handling.

Please treat your valuable optical instrument with the care it deserves. You will be rewarded with the function of a high-performance instrument which will deliver constant precision for decades.

Our products are famous for this.

However, if your instrument should not work perfectly, please contact the approved technician, your Leica representative, or Leica Microsystems (Switzerland) Ltd., CH-9435 Heerbrugg directly.

Calculating total magnification and object field diameter

| | |
|-----------|------------------------------------------------------------------------------------------------------------------------------------------------------------------------------------------------|
| M_O | magnification of the additional objective |
| M_E | magnification of the eyepiece |
| z | position of the magnification changer |
| N_{FOV} | field number of the eyepiece. Field numbers are printed on the eyepieces: $10\times/20$, $16\times/16$, $20\times/12$, $10\times/20B$, $16\times/14B$, $25\times/9.5B$, $40\times/6B$ |

Example:

| | |
|-------|-----------------------------------|
| M_O | additional objective 0.5 \times |
| M_E | eyepiece 20 $\times/12$ |
| z | zoom position 5.0 |

Magnification in the binocular tube:

$$M_{TOT\ VIS} = M_O \times M_E \times z \quad 0.5 \times 20 \times 5 = 50$$

Object field diameter in the object:

$$\varnothing_{OF} = \frac{N_{FOV}}{M_O \times z} = \frac{12}{0.5 \times 5} = 4.8 \text{ mm}$$

Optical data of the Leica EZ5

| | | | | 0.63× | | 0.5× | |
|------------------|---------------|---------------------|----------------------|---------------------|----------------------|---------------------|----------------------|
| Working distance | | 100 mm | | 140mm | | 180mm | |
| Eyepieces | Zoom position | Total magnification | Object field ∅ mm | Total magnification | Object field ∅ mm | Total magnification | Object field ∅ mm |
| | | 10×/20 | 1 | 10 | 20 | 6.3 | 31.7 |
| 10×/20B | 1.25 | 12.5 | 16 | 7.9 | 25.4 | 6.3 | 32 |
| | 1.6 | 16 | 12.5 | 10.1 | 19.8 | 8 | 25 |
| | 2 | 20 | 10 | 12.6 | 15.9 | 10 | 20 |
| | 2.5 | 25 | 8 | 15.8 | 12.7 | 12.5 | 16 |
| | 3.2 | 32 | 6.3 | 20.2 | 9.9 | 16 | 12.5 |
| | 4 | 40 | 5 | 25.2 | 7.9 | 20 | 10 |
| | 5 | 50 | 4 | 31.5 | 6.3 | 25 | 8 |
| 16×/15B | 1 | 16 | 15 | 10.1 | 23.8 | 8 | 30 |
| | 1.25 | 20 | 12 | 12.6 | 19 | 10 | 24 |
| | 1.6 | 25.6 | 9.4 | 16.1 | 14.9 | 12.8 | 18.8 |
| | 2 | 32 | 7.5 | 20.2 | 11.9 | 16 | 15 |
| | 2.5 | 40 | 6 | 25.2 | 9.5 | 20 | 12 |
| | 3.2 | 51.2 | 4.7 | 32.3 | 7.4 | 25.6 | 9.4 |
| | 4 | 64 | 3.8 | 40.3 | 6 | 32 | 7.5 |
| | 5 | 80 | 3 | 50.4 | 4.8 | 40 | 6 |
| 20×/12 | 1 | 20 | 12 | 12.6 | 19 | 10 | 24 |
| | 1.25 | 25 | 9.6 | 15.8 | 15.2 | 12.5 | 19.2 |
| | 1.6 | 32 | 7.5 | 20.2 | 11.9 | 16 | 15 |
| | 2 | 40 | 6 | 25.2 | 9.5 | 20 | 12 |
| | 2.5 | 50 | 4.8 | 31.5 | 7.6 | 25 | 9.6 |
| | 3.2 | 64 | 3.8 | 40.3 | 6 | 32 | 7.5 |
| | 4 | 80 | 3 | 50.4 | 4.8 | 40 | 6 |
| | 5 | 100 | 2.4 | 63 | 3.8 | 50 | 4.8 |

Dimensions of the Leica EZ5 (in mm)

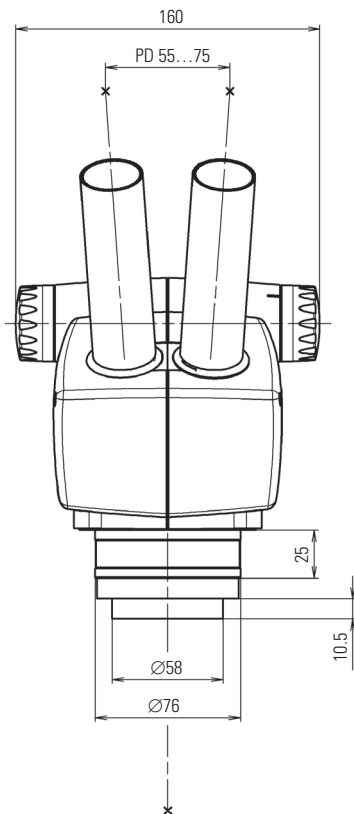
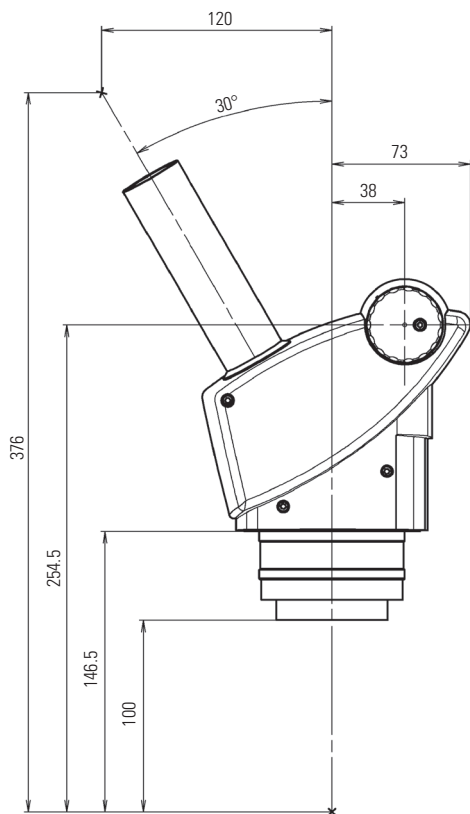

0.63× additional objective

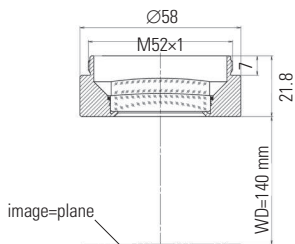

0.5× additional objective

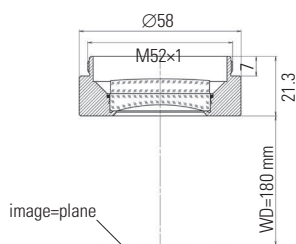

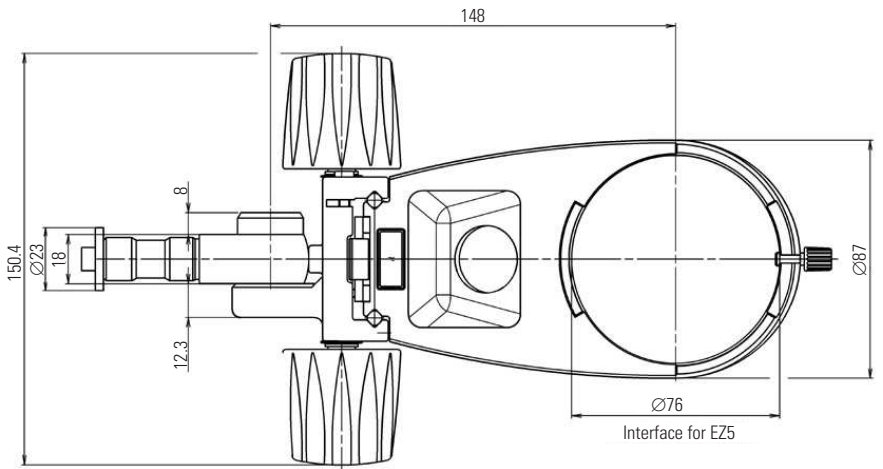
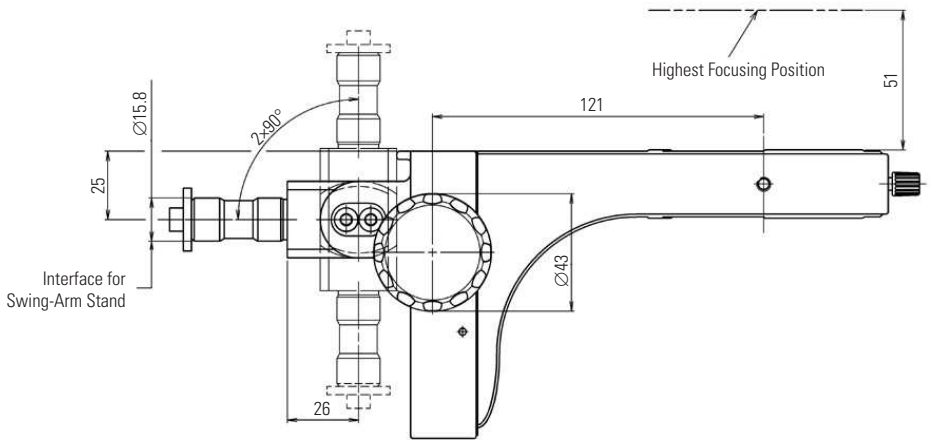

10 447 255 Mountable focus arm

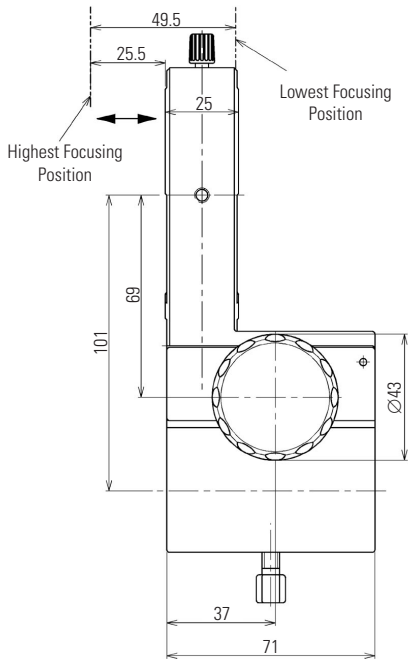

10 446 344 Focus arm for 25 mm post

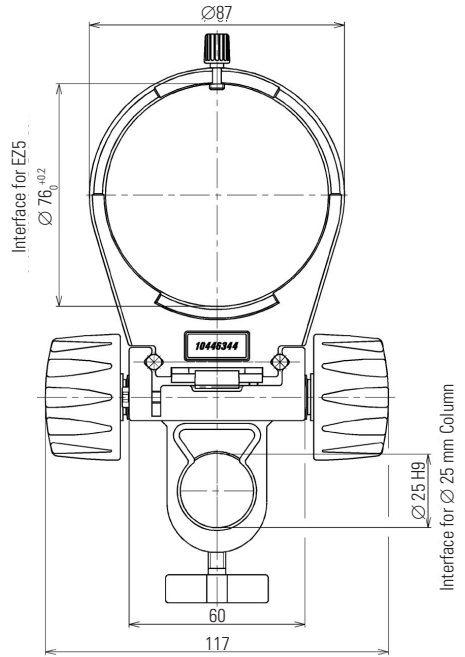

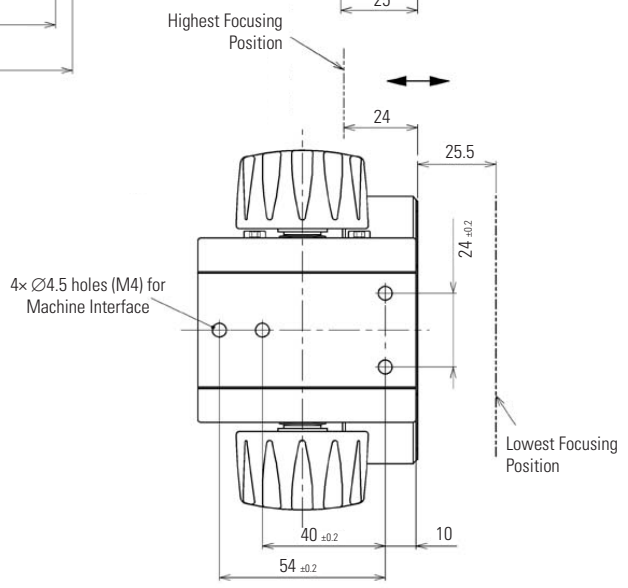
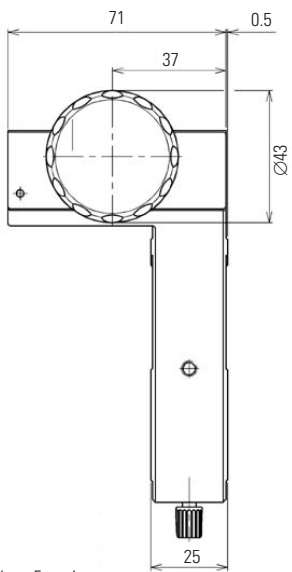
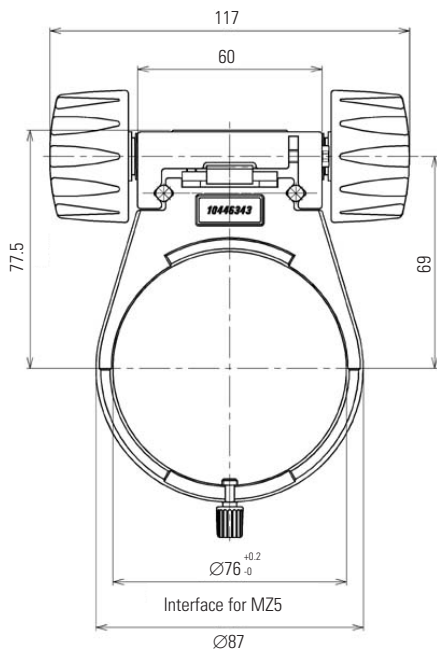

10 446 343 Focus arm

Leica Microsystems around the world

Leica Microsystems is active in the fields of microscopy, sample preparation, image analysis, confocal laser equipment, medical equipment and equipment for the semiconductor industry. The international technology group, which is headquartered in Wetzlar, Germany, developed from a group of companies with proud individual traditions, Wild, Leitz, Reichert, Jung, and Cambridge Instruments.

Made by Leica

Leica Microsystems develops system solutions for enhanced customer benefit and innovative leading edge technologies to standards that command international respect. The same quality standards are applied in all of our 11 production facilities in 7 countries. Leica is thus synonymous with quality the world over.

Leica for you

Technology is one side of the Leica Microsystems success story, the other is customer care. Our staff provide cooperative, professional consulting, service and customer care on site and in our customers' national languages. We also pride ourselves on our ability to provide reliable, uncomplicated solutions to our customers' needs and a flawless delivery program.

Leica Microsystems – the brand for outstanding products

Leica Microsystems' mission is to be the world's first-choice provider of innovative solutions to our customers' needs for vision, measurement and analysis of micro-structures.

Leica, the leading brand for microscopes and scientific instruments, developed from five brand names, all with a long tradition: Wild, Leitz, Reichert, Jung and Cambridge Instruments. Yet Leica symbolizes innovation as well as tradition.

Leica Microsystems – an international company with a strong network of customer services.

| | | | |
|-------------------------|-----------------------|------------------------|------------------------|
| Australia: | Gladesville | Tel. +61 2 9879 9700 | Fax +61 2 9817 8358 |
| Austria: | Vienna | Tel. +43 1 486 80 50 0 | Fax +43 1 486 80 50 30 |
| Canada: | Richmond Hill/Ontario | Tel. +1 905 762 2000 | Fax +1 905 762 8937 |
| Denmark: | Herlev | Tel. +45 4454 0101 | Fax +45 4454 0111 |
| France: | Rueil-Malmaison | Tel. +33 1 47 32 85 85 | Fax +33 1 47 32 85 86 |
| Germany: | Bensheim | Tel. +49 6251 136 0 | Fax +49 6251 136 155 |
| Italy: | Milan | Tel. +39 0257 486.1 | Fax +39 0257 40 3475 |
| Japan: | Tokyo | Tel. +81 3 5421 2800 | Fax +81 3 5421 2896 |
| Korea: | Seoul | Tel. +82 2 514 65 43 | Fax +82 2 514 65 48 |
| Netherlands: | Rijswijk | Tel. +31 70 4132 100 | Fax +31 70 4132 109 |
| People's Rep. of China: | Hong Kong | Tel. +852 2564 6699 | Fax +852 2564 4163 |
| Portugal: | Lisbon | Tel. +351 21 388 9112 | Fax +351 21 385 4668 |
| Singapore | | Tel. +65 6779 7823 | Fax +65 6773 0628 |
| Spain: | Barcelona | Tel. +34 93 494 95 30 | Fax +34 93 494 95 32 |
| Sweden: | Sollentuna | Tel. +46 8 625 45 45 | Fax +46 8 625 45 10 |
| Switzerland: | Glattbrugg | Tel. +41 44 809 34 34 | Fax +41 44 809 34 44 |
| United Kingdom: | Milton Keynes | Tel. +44 1908 246 246 | Fax +44 1908 609 992 |
| USA: | Bannockburn/Illinois | Tel. +1 847 405 0123 | Fax +1 847 405 0164 |

and representatives of Leica Microsystems in more than 100 countries.

In accordance with the ISO 9001 certificate, Leica Microsystems (Switzerland) Ltd, Business Unit Stereo & Microscope Systems has at its disposal a management system that meets the requirements of the international standard for quality management. In addition, production meets the requirements of the international standard ISO 14001 for environmental management.

Winner 2005



Innovationspreis
der deutschen Wirtschaft
The World's First Innovation Award

www.leica-microsystems.com

The companies of the Leica Microsystems Group operate internationally in three business segments, where we rank with the market leaders.

• Microscopy Systems

Our expertise in microscopy is the basis for all our solutions for visualization, measurement and analysis of micro-structures in life sciences and industry. With confocal laser technology and image analysis systems, we provide three-dimensional viewing facilities and offer new solutions for cytogenetics, pathology and materials sciences.

• Specimen Preparation

We provide comprehensive systems and services for clinical histo- and cytopathology applications, biomedical research and industrial quality assurance. Our product range includes instruments, systems and consumables for tissue infiltration and embedding, microtomes and cryostats as well as automated stainers and coverslippers.

• Medical Equipment

Innovative technologies in our surgical microscopes offer new therapeutic approaches in microsurgery.