



Addendum No. 01

Project: Lee County Circuit Courtroom Renovation
Jonesville, Virginia

Date: February 25, 2014

Please incorporate the following changes, deletions, and additions into Contract. Acknowledgements of receipt of this addendum must be noted on your bid form.

1.1 Specification Revisions

1. Change the bid receipt date from March 6, 2014 to March 13, 2014 by 2:00 p.m. in the Advertisement for Bids.

2.1 Drawing Revisions

1. Add the attached Sheet A401 to the drawing set.

3.1 Attachments

1. Sheet A401.
2. Pre-Bid Meeting Minutes.
3. Pre-Bid Meeting Sign-In Sheet.
4. Plan Holder List.

END OF ADDENDUM NO. 01

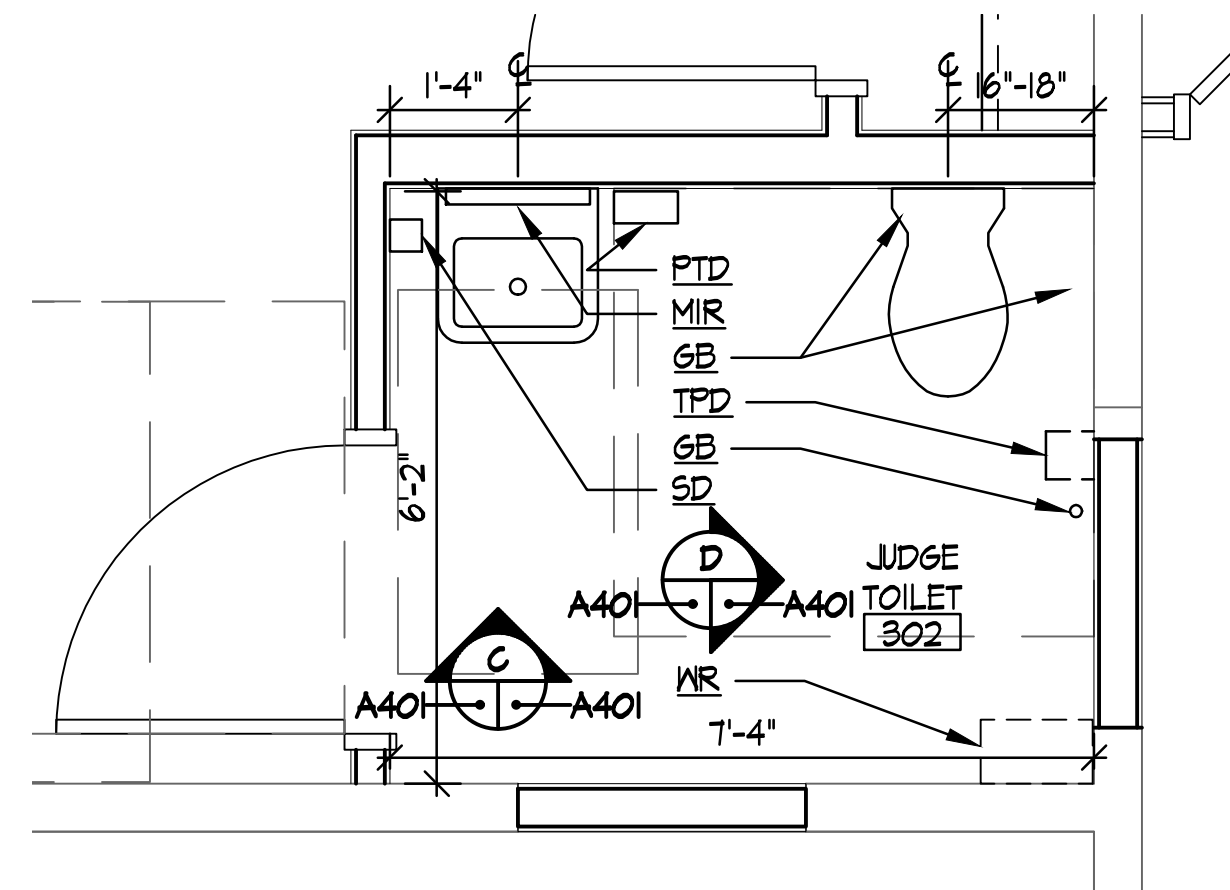

A ENLARGED TOILET PLAN
A101 | A402 SCALE: 1/4" = 1'-0"

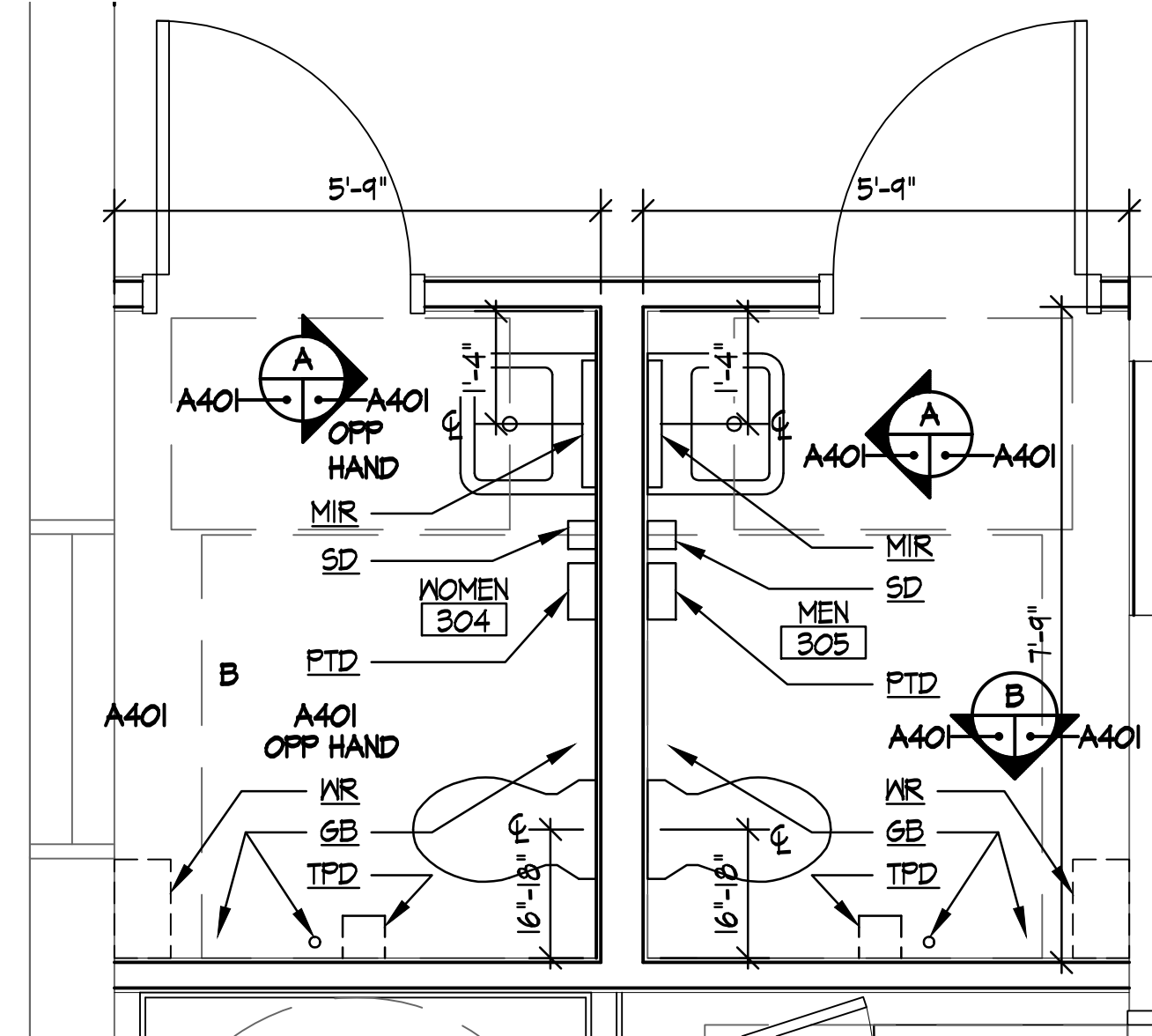

B ENLARGED TOILET PLAN
A101 | A402 SCALE: 1/4" = 1'-0"

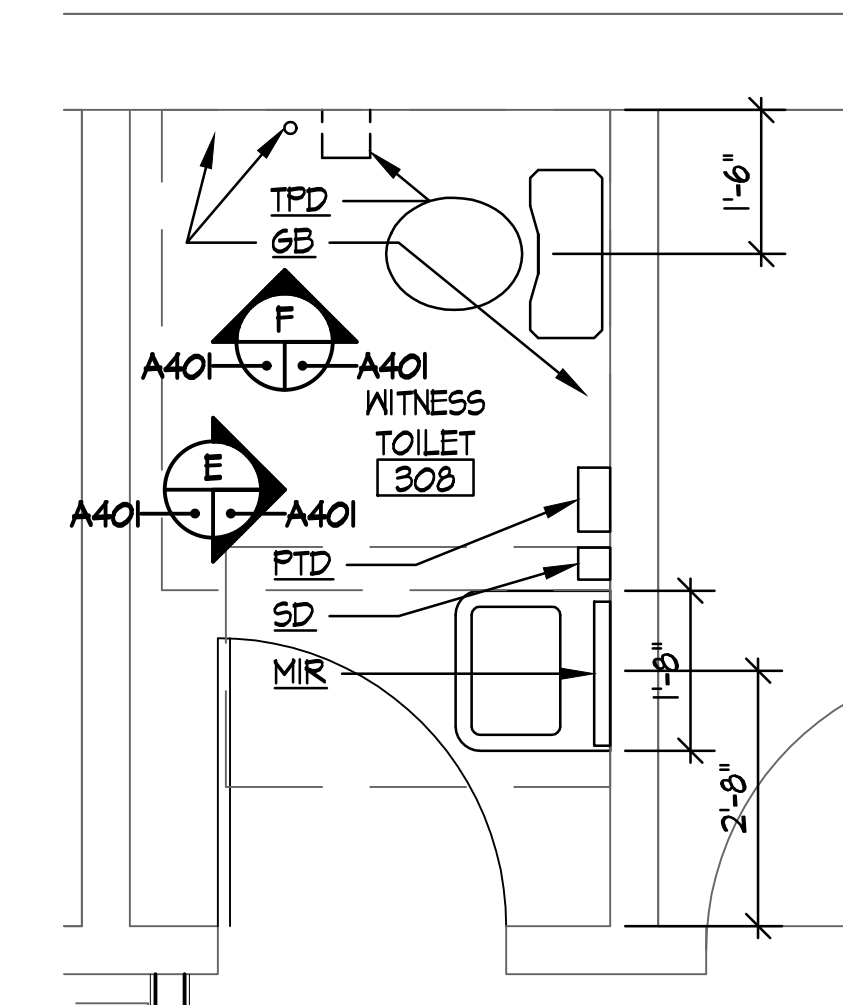

C ENLARGED TOILET PLAN
A101 | A402 SCALE: 1/4" = 1'-0"

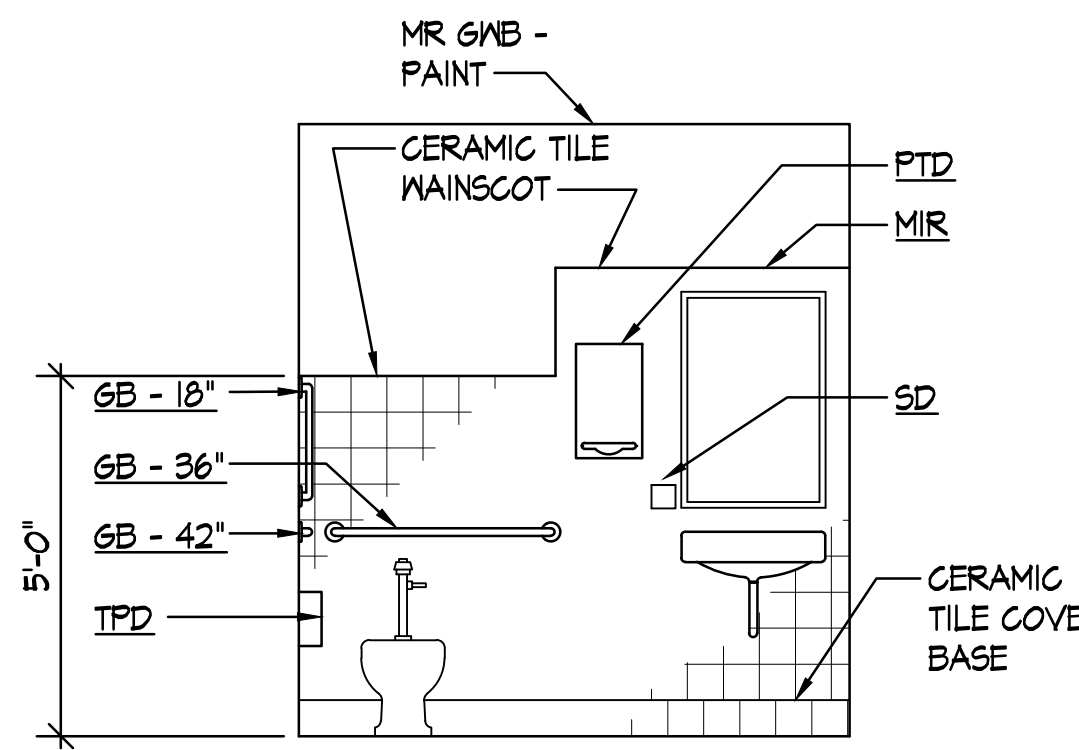

A INTERIOR ELEVATION
A401 | A401 SCALE: 3/8" = 1'-0"

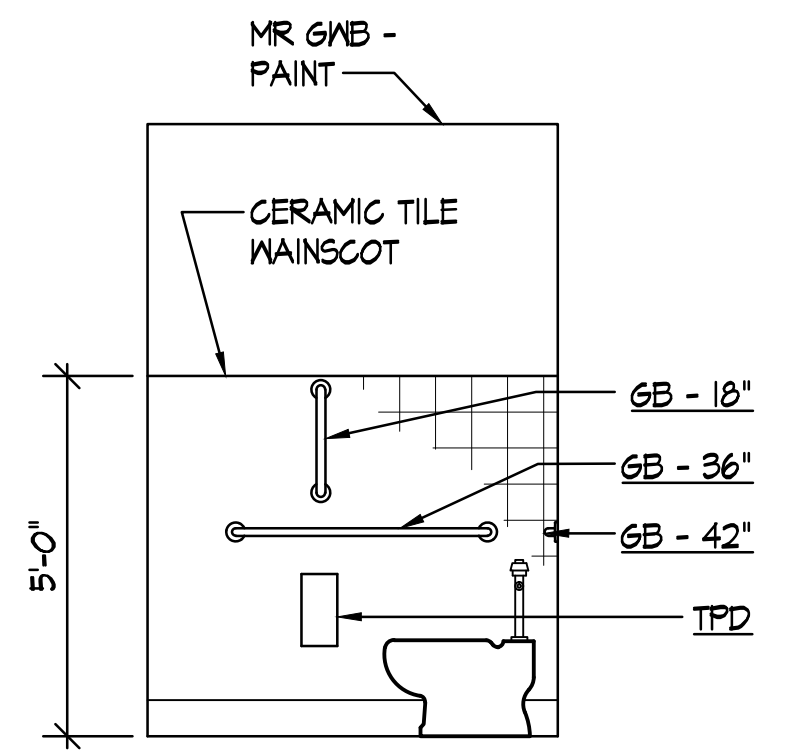

B INTERIOR ELEVATION
A401 | A401 SCALE: 3/8" = 1'-0"

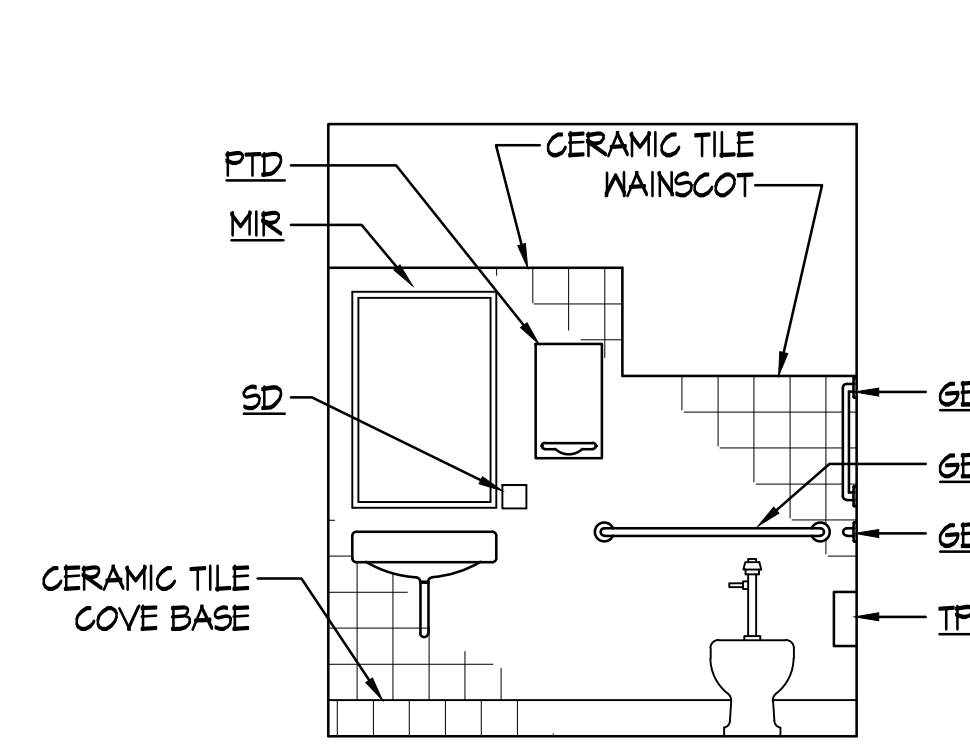

C INTERIOR ELEVATION
A401 | A401 SCALE: 3/8" = 1'-0"

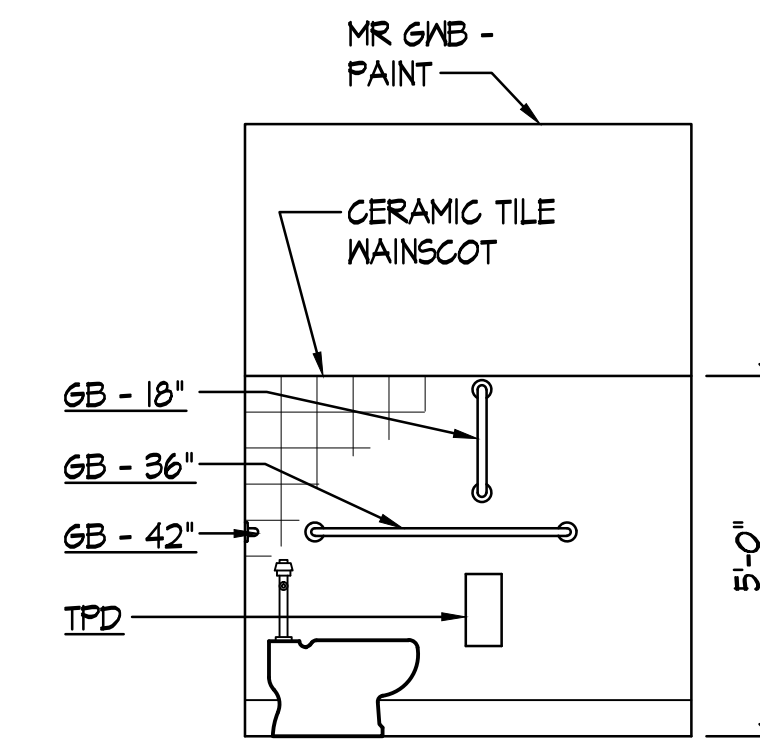

D INTERIOR ELEVATION
A401 | A401 SCALE: 3/8" = 1'-0"

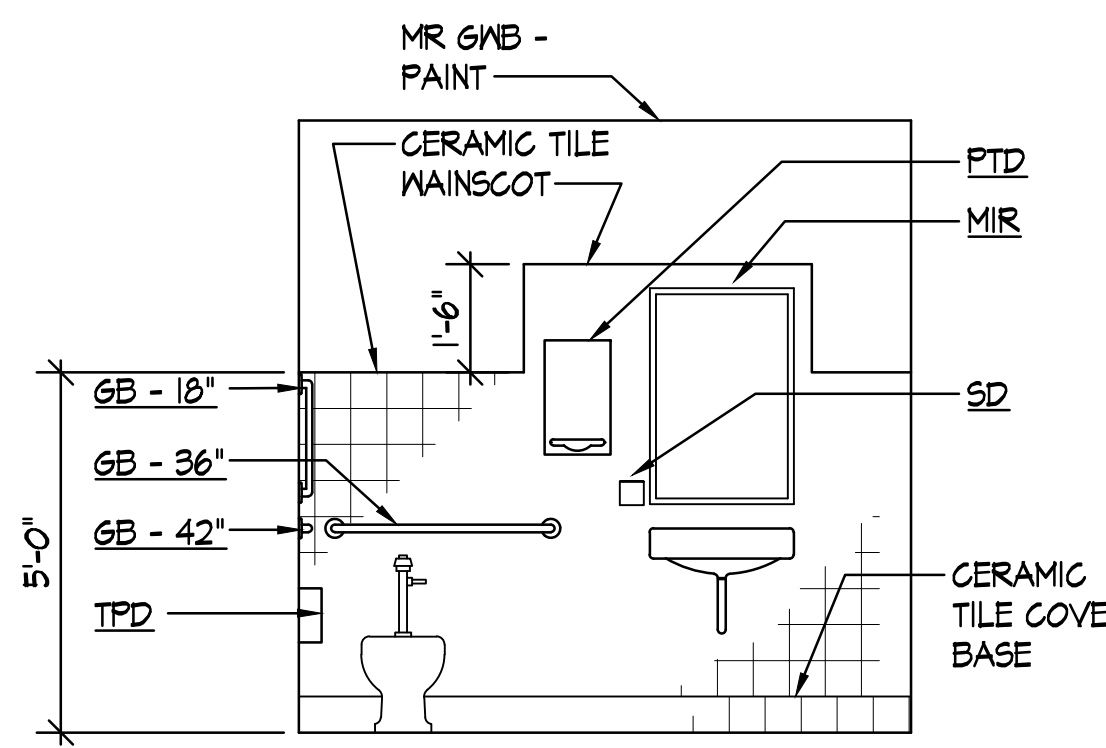

E INTERIOR ELEVATION
A401 | A401 SCALE: 3/8" = 1'-0"

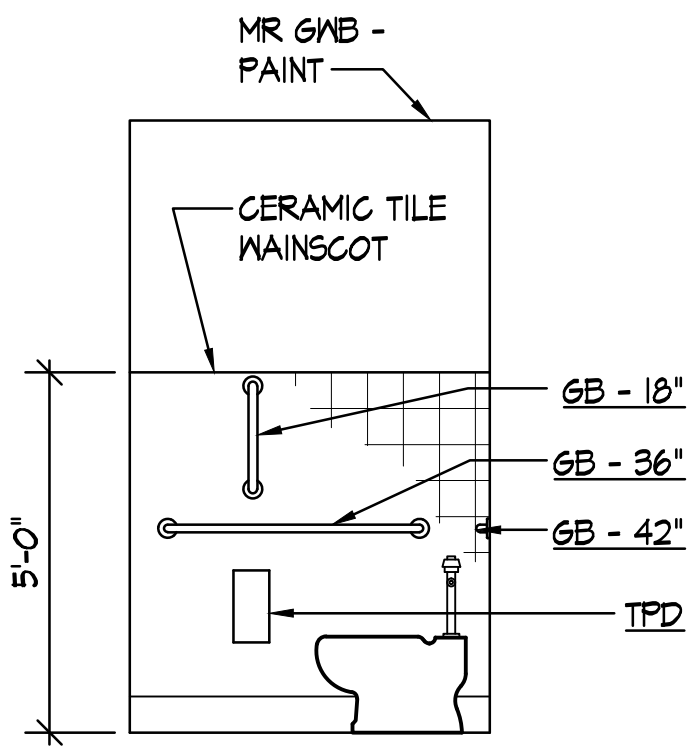

F INTERIOR ELEVATION
A401 | A401 SCALE: 3/8" = 1'-0"

LEGEND	
CH	COAT HOOKS
TPD	TOILET PAPER DISPENSER
MIR	MIRROR - (24" X 36")
GB	GRAB BAR
SD	SOAP DISPENSER
PTD	PAPER TOWEL DISPENSER
WR	WASTE RECEPTACLE (NIC)

NOTES:

1. PROVIDE BLOCKING IN WALLS BEHIND ALL WALL MOUNTED ACCESSORIES AND GRAB BARS AS REQUIRED.
2. FIELD VERIFY ALL DIMENSIONS AND CONDITIONS PRIOR TO FABRICATION AND INSTALLATION OF ITEMS INDICATED.
3. INSTALL GRAB BARS TO WITHSTAND A HORIZONTAL FORCE OF 250 LB APPLIED AT ANY POINT COMPLYING WITH ASTM F446.
4. PROVIDE A COAT HOOK WITH BUMPER ON THE BACK OF ALL SINGLE USE TOILET ROOM DOORS.

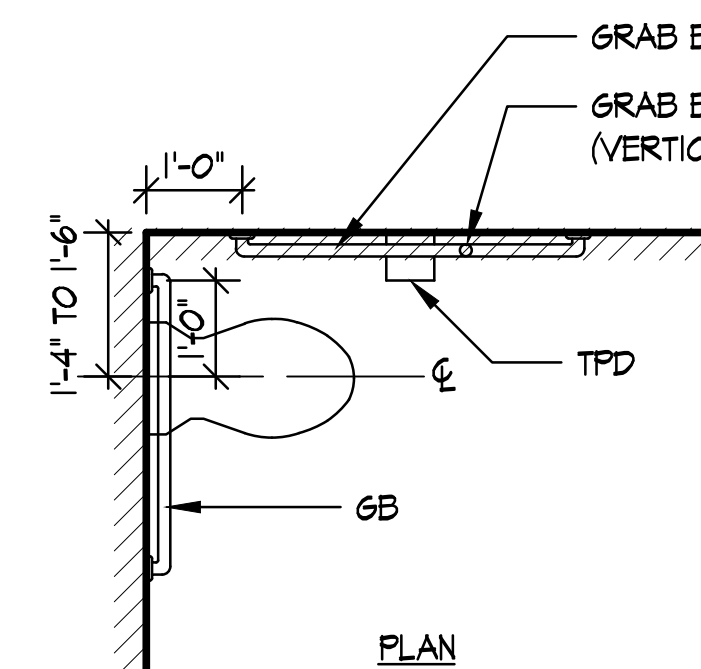
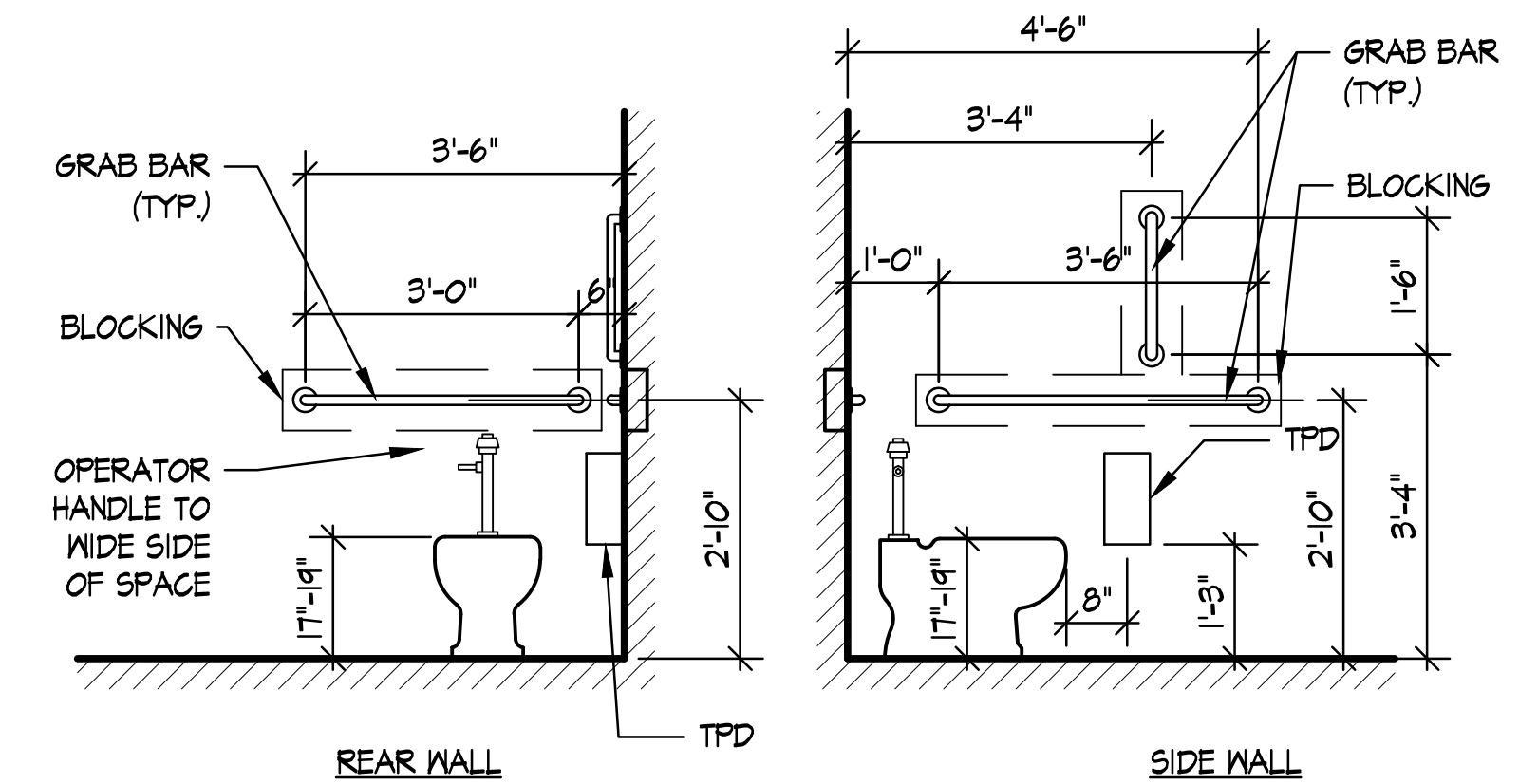

TYPICAL TOILET ROOM DETAILS
SCALE: 1/2" = 1'-0"

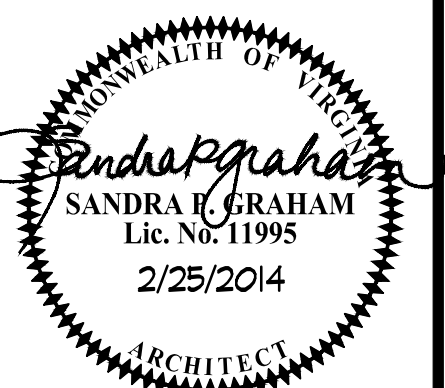
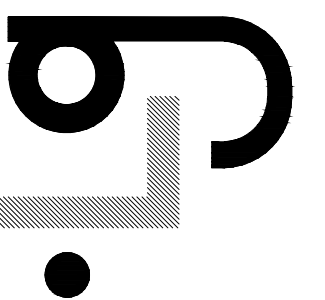

DATE: JANUARY 30, 2014

NO.	REVISION
1	ADDENDUM #1 2/25/2014

SHEET:

A401

TLG PROJECT #13015



PRE-BID MEETING AGENDA

PROJECT: Lee County Circuit Courtroom Renovation
Jonesville, Virginia

MEETING DATE: February 18, 2014

LOCATION: Lee County Courthouse

ATTENDING: See attached sign-in sheet

INTRODUCTIONS

Dane Poe, County Administrator, Lee County
Sandra Graham, Architect, The LANE Group (TLG)

PROJECT DESCRIPTION:

The Project consists of renovations to the existing Lee County Circuit Courtroom, including but not limited to the following:

Renovations to the existing courtroom and associated office spaces, and related electrical and mechanical upgrades. The project includes, but is not limited to, new metal stud partitions; new floor, wall, and ceiling finishes; new courtroom sound system equipment and racks; new wood wainscot in the circuit courtroom; new hardwood judge's bench and jury seating area; and new courtroom wheelchair lifts. Projector, mount, and screen are included in the Judge's Conference Room. New toilet room piping and fixtures, new floor mop sink in the Janitor's closet, and relocation of an existing fire hose, are included as part of the project plumbing requirements. Carpet is included; material cost is included by allowance, installation is included in the base bid.

All work associated with the aluminum window replacement in the Law Library is Additive Bid Item #1.

All work associated with the renovation of the existing Law Library into a Witness Coordinator Waiting and Office area is Additive Bid Item #2.

Asbestos abatement is included in the project. The asbestos report is in the project manual as Appendix 'A'. Abatement includes the VCT in the Courtroom, VCT in the corridor along the Witness Rooms, and areas listed in the report where work is to be completed. Lead Based paint exists on the windows to be replaced in Additive Bid Item #1.

INVITATION FOR BIDS:

1. Bids for the project are due to Mr. Dane Poe, County Administrator at the Lee County Courthouse, Room 111, (P.O. Box 367), in Jonesville, Virginia on **March 6, 2014**

Architects • Engineers • Planners • Environmental Specialists

146 West Main Street • Suite B • Wytheville, VA 24382
276.223.1216 • 276.223.1509 fax • www.thelanegroupinc.com

until 2:00 PM. Bids will be opened and read aloud. Telegraphic or faxed bids will not be considered.

- a. **The bid due date will be changed to March 13, 2014 by 2:00 p.m. in Addendum #01.**
2. Contract Documents may be examined at The LANE Group's Office in Wytheville, Virginia; The LANE Group's Office in Big Stone Gap, Virginia; Lee County Board of Supervisors Office at the Lee County Courthouse Complex in Jonesville, Virginia; AGC Construction News in Blountville, TN; and Builders Exchange Association in Knoxville, TN.
 - a. Bid packages are available by contacting The Lane Group Inc., Wytheville Office at 276-223-1216. **Plan deposit is \$150.00 per set. Bidders will be refunded \$75.00 for each set received by TLG, in good condition, within 10 calendar days after the bid opening.** There is a \$25 charge for shipping and handling on all sets requiring shipping.
 - b. The successful contractor will be given five (5) sets of bid documents free of charge. Additional sets will be available for purchase at the deposit cost (minus the refund) listed above. Shipping charges will apply for copies requiring shipment.

INSTRUCTIONS TO BIDDERS:

1. Bid security is required to be submitted with each Bid in the amount of five percent of the Bid. Bid security may be in the form of a deposit of cash, a certified check on a bank or trust company insured by the Federal Deposit Insurance Corporation in an amount equal to not less than five percent (5%) of the Bid, or a Bid Bond secured by a surety company.
2. A Performance Bond and a Payment Bond is required in the amount of 100% of the contract amount.
3. The Contractor shall provide Liability Insurance coverage. The contractor's liability insurance shall cover the amount of any work done to the existing building, along with all new construction.
4. The owner will maintain property insurance on the existing building.
5. All questions regarding the project plans and specifications shall be faxed, on contractor's standard RFI form, to The Lane Group Inc. 276-223-1509 or emailed to Mrs. Sandra P. Graham, AIA at sgraham@thelanegroupinc.com. **NO ORAL EXPLANATION OF THE DRAWINGS & SPECIFICATIONS WILL BE MADE.**



- a. All questions will be responded to by modifications to documents or listing of question and response in Addendum format. Pre-Bid question forms are available during the meeting today.
6. Withdrawal or Modification of bids per § 2.2 – 4330 of the Code of Virginia.

BID:

1. This is a single source general contractor's lump sum bid. Contractors are requested to submit a list of subcontractors after award, prior to first pay application.
2. One copy of the bid form will be required. The Bid Form must complete and signed to be considered valid; fill in all blanks.
3. Sums shall be expressed in both words and figures. In case of discrepancy, the amount written in words shall govern.
4. No substitutions will be accepted prior to bidding. Substitutions will be reviewed during the shop drawing submittal process and contractor must submit information to prove they are equal to the specified product(s) to be allowed.

SCHEDULE:

1. Contractor to reach substantial completion within 180 calendar days, followed by 30 consecutive calendar days to final completion.
 - a. Liquidated damages are included on the project in the sum of \$150.00 for each consecutive calendar day beyond the completion time listed above.
2. Contractor working hours shall be regular business hours unless otherwise approved by the Lee County Administrator's office.
 - a. Evening and weekend work may be required for demolition work causing higher noise levels.
 - b. Court proceedings in other spaces in the building must not be compromised during construction.
 - c. Court may be held in spaces adjacent to the ongoing work, or within the work area, depending on how much demolition and new work has been completed. If this is required, it will be scheduled with the contractor as to not interfere with the project work schedule.
 - d. Building security is very important. The building is typically secured at 5:00 p.m. each day. Dane Poe will work with the contractor to schedule after hours work times while keeping the building secure. A timeframe was suggested to be from 3:00 p.m. to 12:00 a.m., rather than during the daytime hours.

PROVISIONS:



2. Contractor may use existing power. Contractor must provide all connections to power required for work.
3. Staging area will be located in project work area. If additional staging area is needed, this shall be coordinated with the owner for location. Coordinate location of vehicle parking with the owner.
 - a. Per Dane Poe, the safest way to store materials outside the building/work area, is in a locked trailer. The trailer may be located in the Sheriff's office lot as coordinated with the county.
 - b. Company trucks may be parked around the building when needed for equipment use and loading/unloading. Employees may park at the Health Department building or the Social Services building during regular operating hours. More parking will be available around the Courthouse complex after business hours.
4. Contractors may visit the site with prior approval from Dane Poe, County Administrator.
5. Contractor to provide temporary toilet facilities. Use of the owner's facilities will not be allowed.
6. Provide a telephone on site for use of persons working on the site. Limit use to business calls. A company cell phone is acceptable as long as it is available for owner and A/E use if required, and is on site at all times.
7. Provide a dumpster for items listed for removal. Dispose of all items off-site.
8. No tobacco is allowed on site in any form. No firearms allowed on the Courthouse property. No alcohol allowed on the site.
9. The contractor must not accept direction directly from staff on site. All changes must be reviewed by TLG and the owner and issued to the contractor on contract forms (Field Order, Change Order, etc.).
 - a. The judges may direct the contractor to shut down work due to ongoing court proceedings, especially during a Jury Trial. Please follow the judges' direction in this regard.
10. Review documents and existing conditions in detail, become familiar with extent of work and accuracy of the documents. Notify TLG in writing, on standard RFI form, as soon as a conflict, error, or discrepancy is noted to allow TLG to respond prior to bid submission. (See Information for Bidders).

GENERAL:

1. **The deadline for Pre-Bid Questions is the end of business on Monday, March 3, 2014.** (This has been adjusted from February 24, per the new bid receipt date of March 13.)



2. The contractor will be responsible for applying for and obtaining the permit. The county building official will review plans and issue the permit. TLG has sent a copy of the drawings and specifications to the local building official to assist the contractor timeframe for obtaining the building permit.

AWARD:

1. The anticipated award date will be **30 days** after bid are received. Dependant on the bid amount, the apparent low bid will be presented to the Lee County Board of Supervisors for approval at their next meeting, March 18th.
2. After the agreement is issued, the Notice to Proceed shall be issued within 10 days of fully executed agreement. Contractor will be notified in advance if there will be any delay in the Notice to Proceed.

ADDENDA:

1. **At least one addenda will be issued on the project, and shall contain:**
 - a. Sheet A401.
 - b. Pre-Bid sign-in sheet.
 - c. Pre-Bid Minutes.
 - d. Answers to bid questions submitted to date and any associated construction document modifications required to date.
 - e. Plan Holder List.
2. All addenda will be issued, by email, to every party on the plan holder list, including all plan rooms. Be sure that TLG has the correct email address on file for addenda issuance. Contact Becky Sutphin in the Wytheville office with any updates (276-223-1216 or bsutphin@thelanegroupinc.com).

Walk-through of work area.

END OF PRE-BID MEETING





Lee County Circuit Courtroom Renovation
Pre-Bid Meeting

February 18, 2014 at 10:00 a.m.

Attendee Name: Cliff Sumpter

Company: Pete Sumpter General Contractor, Inc.

Address: 200 Pete Sumpter Drive, Ewing, VA 24248

Phone: 276-861-2201 Fax: 276-861-2203

Email: sumptergci@gmail.com

Attendee Name: Dane Poe

Company: Lee County

Address: Jonesville, VA

Phone: 276-346-7714 Fax: 276-346-7712

Email: ddpoe@leecova.org

Attendee Name: Gary Webb

Company: Burwil Construction

Address: 620 Locust St., Bristol, TN

Phone: 423-968-4158 Fax: _____

Email: nself@burwil.com

Architects • Engineers • Planners • Environmental Specialists

146 West Main Street • Suite B • Wytheville, VA 24382
276.223.1216 • 276.223.1509 fax • www.thelanegroupinc.com

Attendee Name: Ed Conners

Company: ES&A, Inc.

Address: 104 Dundee Circle, Kingsport, TN

Phone: 423-863-9900 Fax: 423-765-1636

Email: Conners55@yahoo.com

Attendee Name: Sandra P. Graham

Company: The LANE Group

Address: 325 E. Main Street, Suite A, Wytheville, VA 24382

Phone: 276-223-1216 Fax: 276-223-1509

Email: sgraham@thelanegroupinc.com

Attendee Name: _____

Company: _____

Address: _____

Phone: _____ Fax: _____

Email: _____



PLACE PROJECT NAME IN THE HEADER

Project Name:	Lee County Circuit Courtroom Renovation				Project #:	13015		
	Jonesville, VA				Ret. Date:			
Bid Date:	March 6, 2014 until 2:00 p.m.							
	Lee County Courthouse Room 111							
						Date Sets	Date Sets	Deposit Ret'd
Set Number	Plan Holder	Address	Phone	Fax	Deposit	Mailed	Returned	Amount/Date
Set #1	D. Dane Poe, County Administrator	Lee County Courthouse	276-346-7714	276-346-7712	N/A	2/14/2014		
(Owner Set)	Lee County Board of Supervisors	33640 Main St., Room 111						
Add:	ddpoe@leecova.org	Jonesville, VA 24263						
Set #2	The Lane Group	325 East Main Street	276-223-1216	276-223-1509	N/A		N/A	
(Office Set)	Sandra P. Graham	Suite A						
Add:	sgraham@thelanegroupinc.com	Wytheville, VA 24382						
Set #3	The Lane Group	316 East Fifth Street South	276-523-3771	276-523-3568	N/A	2/14/2014		
(Office Set)	Paula Riffe	PO Box 452						
Add:	priffe@thelanegroupinc.com	Big Stone Gap, VA 24219						
Set #4	Builders Exchange of TN	300 Clark Street	865-525-0443	addenda	N/A	2/14/2014		
(Plan Room)	Attn: Lari Meadors	Knoxville, TN 37921		reporter@bxtn.org				
Add:	reporter@bxtn.org							
Set #5	The AGC of Tennessee, Tri-Cities Branch	249 Neal Drive	423-323-7121	423-279-0989	N/A	2/14/2014		
(Plan Room)	Attn: Judy Donley	Blountville, TN 37617						
Add:	judy@tricitiestnagc.org							
Set #6	McGraw-Hill Construction/Dodge	MHC/Bizport	804-594-2682	addenda		2/14/2014		
(Plan Room)	Attn: Andrea Kerwin	9 N. Third Street		dodge_document_ca@mhfi.com				
Add:	andrea.kerwin@mhfi.com	Richmond, VA 23219						
Set #7	Reed Construction Data	30 Technology Pkwy S.	770-209-3374	addenda				
(Plan Room)	Attn: Stacy Dorroh	Ste. 100		addenda@reedbusiness.com				
Add:	stacy.dorroh@reedbusiness.com	Norcross, GA 30092						
Set #8	Pete Sumpter General Contractor, Inc.	200 Pete Sumpter Drive	276-861-2201		Ck #17907	2/14/2014		
(Contractor)	Pete Sumpter	Ewing, VA 24248	276-861-2203		\$ 175.00			
Add:								
Set #9	Armstrong Construction	151 Shelby Street	423-246-6185	423-246-7608	Ck #20148	2/14/2014		
(Contractor)	Ben McMurry	PO Box 8			\$ 175.00			
Add:		Kingsport, TN 37662						
Set #10	BurWil Construction Company, Inc.	620 Locust Street	423-968-4158	423-968-3199	Ck #082948	2/14/2014		
(Contractor)	Nick Self, VP of Operations	Bristol, TN 37620			#082954			
Add:	mfogleman@burwil.com				\$ 175.00			
Set #11	Odyssey Engineering and Electrical, Inc.	5069 Bopp Hill Road	540-980-4004		N/A	2/14/2014		
(Engineering)	Robert Bopp / Kathy Bopp	Pulaski, VA 24301	540-250-0949					
Add:	rbopp@odysseyeng.com	ktbopp@odysseyeng.com						
Set #12	Lee County Building Official	Lee County Courthouse	276-346-7715		N/A	2/14/2014		
(Bldg. Official)	Roger Susong, Building Official	33640 Main St., Room 206						
Add:	rsusong@leecova.org	Jonesville, VA 24263						

