

RCA

TV/VCR User's Guide

Changing Entertainment. Again.



Important Information

WARNING

To reduce the risk of fire or electric shock, do not expose this product to rain or moisture.

WARNING

RISK OF ELECTRIC SHOCK
DO NOT OPEN

To reduce the risk of electric shock, do not remove cover (or back). No user serviceable parts inside. Refer servicing to qualified service personnel.



This symbol indicates "dangerous voltage" inside the product that presents a risk of electric shock or personal injury.



This symbol indicates important instructions accompanying the product.

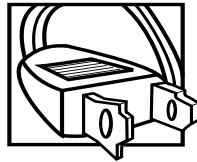

Caution: To prevent electric shock, match wide blade of plug to wide slot, fully insert.

Attention: Pour éviter les chocs électriques, introduire la lame la plus large de la fiche dans la borne correspondante de la prise et pousser jusqu'au fond.

Refer to the identification/rating label located on the back panel of your product for its proper operating voltage.

FCC Regulations state that unauthorized changes or modifications to this equipment may void the user's authority to operate it.

Caution: Using video games or any external accessory with fixed images for extended periods of time can cause them to be permanently imprinted on the picture tube (or projection TV picture tubes). ALSO, some network/program logos, phone numbers, etc. may cause similar damage. This damage is not covered by your warranty.

Cable TV Installer: This reminder is provided to call your attention to Article 820-40 of the National Electrical Code (Section 54 of the Canadian Electrical Code, Part 1) which provides guidelines for proper grounding and, in particular, specifies that the cable ground shall be connected to the grounding system of the building as close to the point of cable entry as practical.

Product Registration

Please fill out the product registration card and return it immediately. Returning the card allows us to contact you if needed.

Keep your sales receipt to obtain warranty parts and service and for proof of purchase. Attach it here and record the serial and model numbers in case you need them. The numbers are located on the back of the television.

Model No. _____

Serial No. _____

Purchase Date: _____

Dealer/Address/Phone: _____

Key Features Overview

Your TV/VCR is equipped with features that will add to your TV/VCR viewing experience. The following information summarizes a few of these features. Chapter 2 provides more information about the rest of the TV/VCR's features and how to use them.

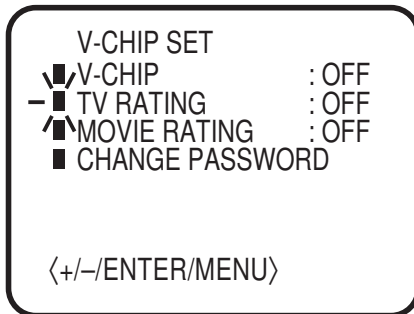

V-Chip

Description: You can block programs and movies by TV and movie ratings.

Requirements:

- Set up the *V-CHIP* in the TV/VCR's *MENU* (go to Chapter 2 for details).
- The broadcasters must use the rating system when they send the program to your TV/VCR in order for your TV/VCR to block the program.

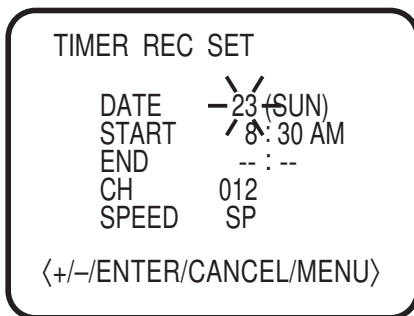

8 Program Recording (Timer Recording)

Description: You can manually set up timer recording to program the TV/VCR to record up to eight different programs. This is useful if you plan on being away from home for a long period of time. Before setting the timer, make sure that the clock is set correctly.

Requirements:

- Set the clock on the TV/VCR (go to Chapter 1 for details).
- Set the timer to record your programs in the *TIMER REC SET* menu (go to Chapter 2 for details).

(This page intentionally left blank)

Introduction

Key Features Overview	1
V-Chip	1
8 Program Recording (Timer Recording)	1

Chapter 1: Connections & Setup

Things to Consider Before You Connect	6
Protect Against Power Surges	6
Protect Components from Overheating	6
Position Cables Properly to Avoid Audio Interference	6
Important Stand and Base Safety Information	6
Use Indirect Light	6
Connection Pictures	6
Connect the TV/VCR	7
TV/VCR Connection	7
Jacks on the Back of Your TV/VCR	8
Plug in the TV/VCR	9
Put Batteries in the Remote	9
Turn on the TV/VCR	9
TV/VCR Setup	9
Setting the Clock	10
Setting Up Your Channels	11
VCR Basics	13
Playing a Tape	13
Automatic Rewind	13
Basic Recording	13
Checking the Safety Tab	13
The Buttons on the Remote Control	14

Chapter 2: Using the TV/VCR's Features

V-Chip	18
How V-Chip Works	18
Setting the Password	18
V-Chip TV Rating	19
Blocking Specific Content Themes	20
V-Chip Movie Rating	20
Turning On V-Chip Ratings	21
Changing the Password	21
Recording Features	22
Recording Speeds	22
Recording Pause	22
Types of Recording	22
One-Touch Recording (OTR)	23
Timer Recording	23

Table of Contents

Picture Search Options	25
Tracking	25
Time Counter	26
Channel Banner	26
Sleep Timer	27
Using Closed Captioning	27
Chapter 3: Using the TV/VCR's Menu System	
How to Use Your TV/VCR's Menu System	30
Menus	30
Setting the On/Off Timer	30
Picture Menu	31
System Set-up Menu	31
Additional Features in the Menu	32
Chapter 4: Other Information	
Troubleshooting	34
Care and Cleaning	36
Front Panel	36
RCA TV/VCR Limited Warranty	37
Index	41

Connections & Setup

Chapter Overview:

- Things to Consider Before You Connect
- Connect the TV/VCR
- Plug in the TV/VCR
- Put Batteries in the Remote
- Turn on the TV/VCR
- TV/VCR Setup
- VCR Basics
- Buttons on the Remote Control

Changing Entertainment. Again.



Things to Consider Before You Connect

Protect Against Power Surges

- Connect all components before you plug any of their power cords into the wall outlet.
- Turn off the TV/VCR and/or component before you connect or disconnect any cables.
- Make sure all antennas and cables are properly grounded. Refer to the Important Safeguards sheet packed with your TV/VCR.

Protect Components from Overheating

- Don't block ventilation holes on any of the components. Arrange the components so that air can circulate freely.
- Don't stack components.
- When you place components in a stand, make sure you allow adequate ventilation.
- If you connect an audio receiver or amplifier, place it on the top shelf so the heated air from it won't flow around other components.

Position Cables Properly to Avoid Audio Interference

- Insert each cable firmly into the designated jack.
- If you place components above the TV/VCR, route all cables down the side of the back of the TV/VCR instead of straight down the middle of the back of the TV/VCR.
- If your antenna uses 300-ohm twin lead cables, do not coil the cables. Also, keep the twin lead cables away from audio/video cables.

Important Stand and Base Safety Information

Choose the location for your TV/VCR carefully. Place the TV/VCR on a stand or base that is of adequate size and strength to prevent the TV/VCR from being accidentally tipped over, pushed off, or pulled off. This could cause personal injury and/or damage the TV/VCR. Refer to the Important Safeguards sheet packed with your TV/VCR.

Use Indirect Light

Don't place the TV/VCR where sunlight or room lighting will be directed toward the screen. Use soft or indirect lighting.

Connection Pictures

Audio/video cables are usually bundled together. For better visibility, the connection pictures in this book show each cable separately (audio left, audio right, and video).

Connect the TV/VCR

There are several ways to connect your TV/VCR. If you want to connect your TV/VCR to another component, see the User's Manual of the component for your connection. For an explanation of the back panel jacks go to page 8.

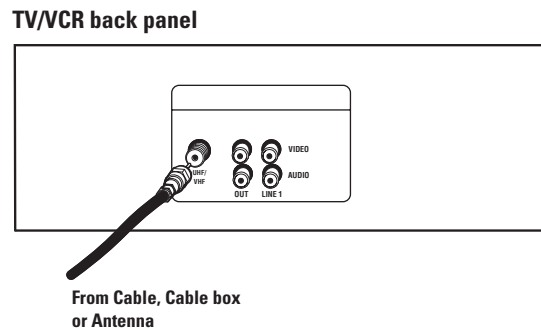

TV/VCR Connection

1. Connect the TV/VCR to your cable or antenna

Connect a coaxial cable from your cable or antenna to the UHF/VHF jack on the back of your TV/VCR.

Jacks on the Back of Your TV/VCR

If you are connecting many components, please consult the manual that came with each component for connection instructions. The picture of your TV/VCR's back panel describes the jacks on the back of your TV/VCR and what types of components that you can connect to these jacks.

When connecting, make sure you connect Output jacks to Input jacks, Video to Video, etc.

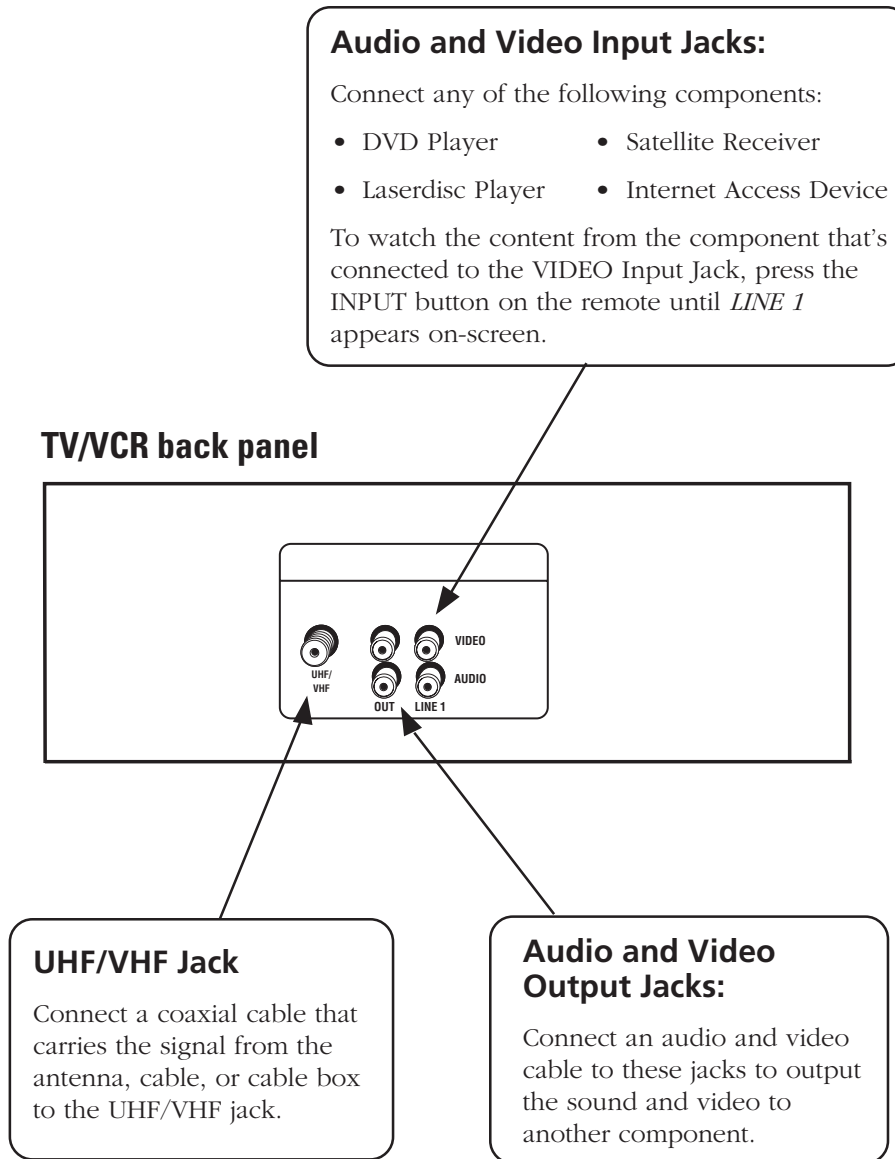

Plug in the TV/VCR

Plug the end of the power cord into the wall outlet. Match the wide blade of the plug with the wide slot in the outlet. Insert the plug completely into the outlet.

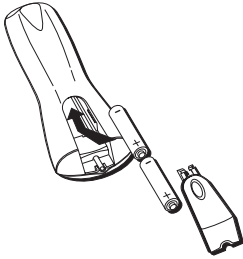

Put Batteries in the Remote

1. Remove the battery compartment cover on the remote.
2. Insert new batteries. Match the polarities (+ and -) on the batteries with the diagram on the remote.
3. Put the battery compartment cover back on the remote.

Turn on the TV/VCR

Press POWER on front of the TV/VCR or press ON•OFF on the remote. The POWER indicator on the front of the TV/VCR will light when the TV/VCR is on.

Set the Language (Escoja un idioma/Choisissez une langue)

Your TV automatically displays the Language Menu when you press MENU for the first time. Follow these steps to change the language:

1. Press the up or down arrow button to choose between English, Spanish and French, then press ENTER to select the language.
2. Press MENU twice to return to normal TV viewing.

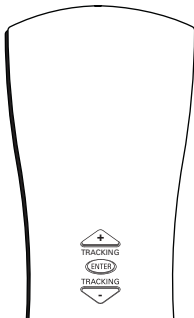

Use the arrow buttons and the ENTER button to move through the menu system.

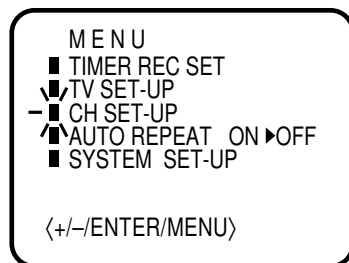

TV/VCR Setup

To complete the TV/VCR setup press MENU to display the *MENU*. The *SYSTEM SET-UP* menu appears for you to set the clock. Once you have set the clock, there are several other steps you must complete in order to customize your TV/VCR, such as setting channels and signal type. Complete the following steps to setup your TV/VCR correctly.

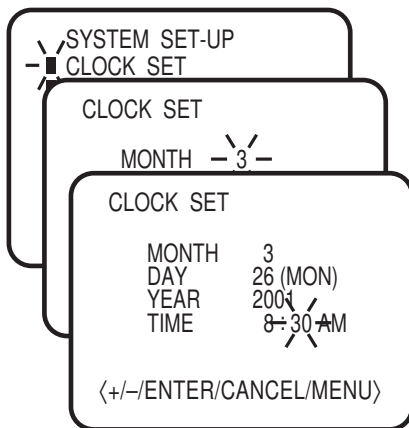

Setting the Clock

The first step of the TV/VCR setup is setting the clock. You must set the clock in order to program a timer recording. To set the clock:

1. If the *SYSTEM SET-UP* menu is not displayed, press MENU.
2. Press ENTER (*CLOCK SET* appears).
3. Press the up or down arrow to set the month, then press ENTER to select the next setting.
4. To set the day, year and time repeat step 3. (The AM/PM setting will change as you set the hour).
5. Make sure all the information has been set correctly. If you made a mistake, press CANCEL until the item you want to correct is selected. Then press the up or down arrow to correct the setting.
6. Press MENU until the *SYSTEM SET-UP* menu disappears.

After the time has been set, you might have to set your Time Zone and Daylight Savings Time.

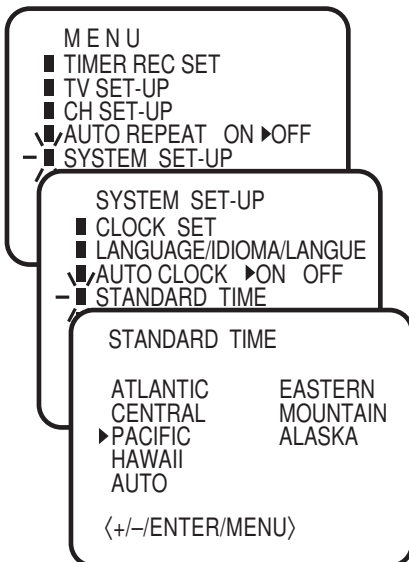

Setting the Time Zone

1. Press the MENU on the remote (the *MENU* appears).
2. Press the down arrow button to select *SYSTEM SET-UP*, then press ENTER (*SYSTEM SET-UP* appears).
3. Press the down arrow button to select *STANDARD TIME*, then press ENTER (*STANDARD TIME* appears).
4. Press the up or down arrow button to select your time zone. Press ENTER when you have selected the time zone.
5. Press the MENU button until the *MENU* screen disappears.

Once you have set your time zone you might need to set the Daylight Saving Time.

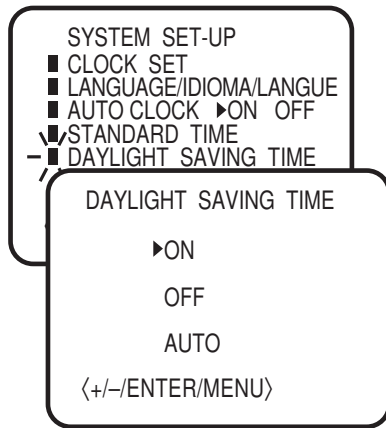

Setting Daylight Saving Time

The Daylight Saving Time is set to the *AUTO* position by default. If you want to set the time manually you need to set it “*ON*” on the first Sunday in April, and set it “*OFF*” on the last Sunday in October.

Note: *If your area does not have Daylight Saving Time, you need to set the position to OFF.*

1. Press the MENU on the remote (the *MENU* appears).
2. Select *SYSTEM SET-UP*, then press ENTER.
3. Select *DAYLIGHT SAVING TIME*, then press ENTER.
4. Press the up or down arrow button to either turn *ON* or *OFF* Daylight Saving Time.
5. Press the MENU button until the *MENU* screen disappears.

Setting Up Your Channels

The TV/VCR is set to receive TV cable channels. If you want the TV/VCR to receive UHF/VHF channels, follow the directions below.

1. Press MENU on the remote (the *MENU* appears).
2. Press the down arrow button to select *CH SET-UP*, then press ENTER.
3. Press ENTER to select *TV* mode.
4. Press MENU until the *MENU* screen disappears.

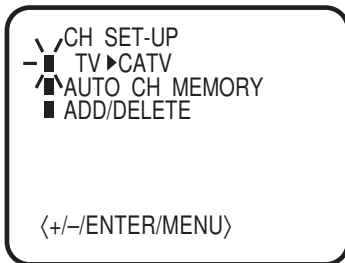

Complete Auto Channel Memory

The Auto Channel Memory allows the TV/VCR to search for all channels viewable through your antenna or cable TV system. This is sometimes called “auto programming.”

1. Press MENU on the remote (the *MENU* appears).
2. Press the down arrow button to select *CH SET-UP*, then press ENTER.
3. Press the down arrow button to select *AUTO CH MEMORY*, then press ENTER. The TV searches for all available channels and will place them into your TV’s memory.
4. Press MENU until the *MENU* screen disappears.

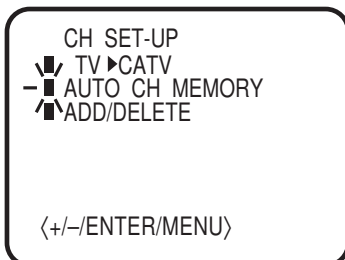

Adding or Removing Channels

You might want to add or remove channels if some of them are not active, have weak signals, or you do not want them in your channel memory. A channel that has been removed can still be selected by pressing the remote control's number buttons.

1. Press MENU on the remote (the *MENU* appears).
2. Press the down arrow button to select *CH SET-UP*, then press ENTER.
3. Press the down arrow button to select *ADD/DELETE*, then press ENTER.
4. Use the number buttons to enter the channel you want to add or delete. Press ENTER to add or delete the channel. The screen shows whether the TV adds or deletes the channel.
5. Press MENU until the *MENU* screen disappears.

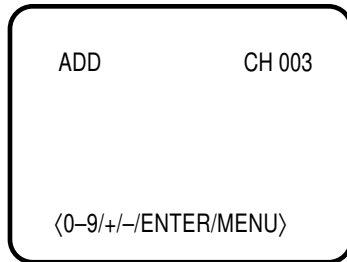

VCR Basics

Now that you've finished the initial setup, you can watch TV. You can also begin using your VCR. In order to begin, you must first understand some basic concepts.

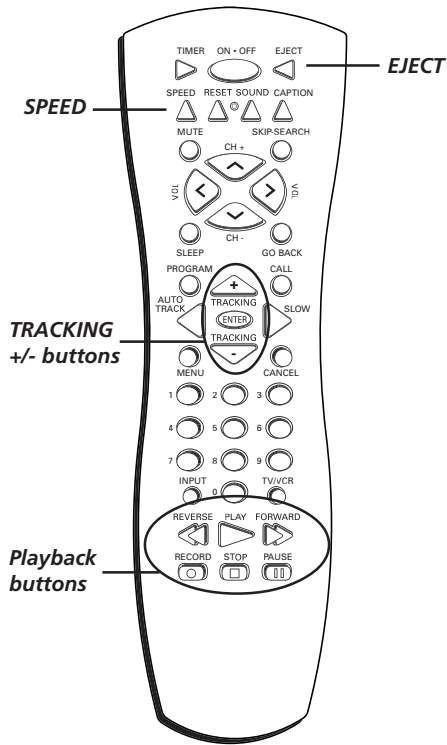

Playing a Tape

Insert a tape in the TV/VCR.

The tape automatically begins playback (if the safety tab on the tape is removed).

- Press FORWARD or REVERSE on the remote (FWD or REW on the front panel) to position the tape.
- Press PLAY (if necessary) to begin tape play.
- Press PAUSE for stop action.
- Press TRACKING up or down (TRACKING + or - on the remote control) to remove any streaks from the picture, if necessary.
- Press STOP to stop playing the tape.
- Press EJECT to eject the tape.

Automatic Rewind

The TV/VCR automatically rewinds the tape when it reaches the end of the tape during playback and the TV/VCR will eject the tape.

Basic Recording

1. Set the tape speed by pressing the SPEED button on the remote. See Chapter 2 for more details on tape speed.
2. Press the RECORD button to begin recording.
3. Press STOP when you want to stop recording.

If you want to pause the recording for a short time (such as during a commercial), press PAUSE instead of STOP.



Checking the Safety Tab

To record, you must insert a tape into the TV/VCR that has its safety tab in place. You can't record on a tape with the safety tab removed. If the safety tab is removed and you want to record on it, simply cover the hole with adhesive tape.

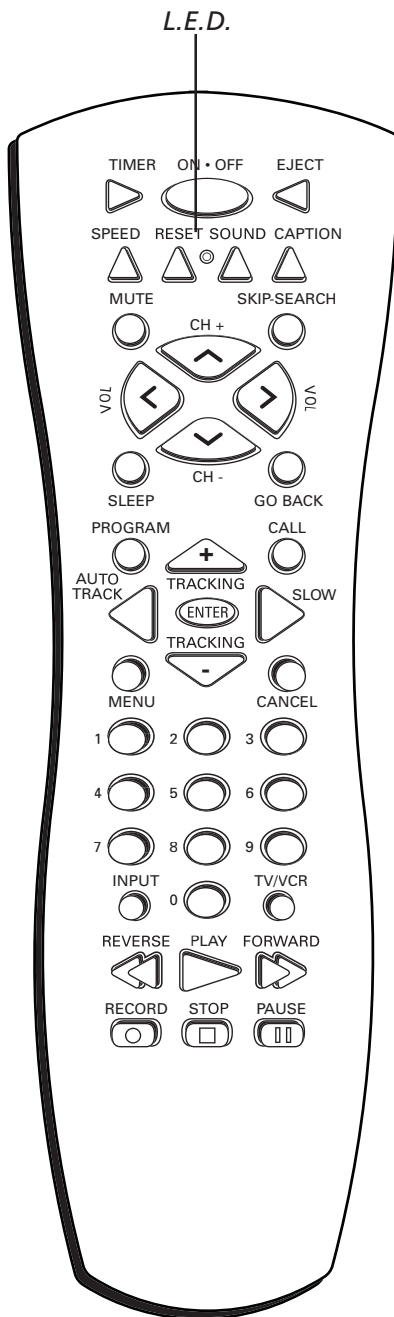

The Buttons on the Remote Control

0-9 (Number buttons) Enter channel numbers and your V-CHIP password directly through the remote control.

If you are receiving UHF/VHF channels, select a channel by pressing two number buttons. For example, to select channel 2, press 0, then 2.

If you are receiving cable channels, select channels 1-12 by pressing three number buttons. For example, to select channel 9 press 0, then 0 and then 9. To select channels 13-99, press the two number buttons in order. To select channels 100-125, press the three number buttons in order.

Arrow + and - buttons (up and down) Press the arrow buttons to move through the on-screen menu system.

AUTO TRACK Allows automatic reduction of streaks which might appear during regular or slow-motion playback.

CALL Displays TV/VCR's current status. Displays the time counter when a tape is inserted. Press again to remove call.

CANCEL Clears settings in menu screens that require you to enter information (for example, entering information for a timer recording).

CAPTION Switches between Caption, Text and TV modes for Closed-Captioned programs.

CH (up and down) buttons Scan up or down through stored channels. Press once to change the channel up or down; press and hold to continue changing channels.

EJECT Ejects a tape.

ENTER When a menu is on the screen, press ENTER to select the item that is highlighted.

FORWARD Fast forwards the tape when the TV/VCR is stopped. Also searches the picture in forward motion during playback.

GO BACK Switches between the last two channels selected.

INPUT Switches the program for viewing between the VCR and external input sources.

L.E.D. (light-emitting diode) The little light on the remote that lights when you press a valid button on the remote.

MENU Displays the TV/VCR's MENU.

MUTE Lowers the TV/VCR volume to its minimum level. Press again to restore volume.

ON • OFF Turns the TV/VCR on and off.

PAUSE Pauses the tape during playback. Also pauses the tape during recording to prevent recording of unwanted scenes.

PLAY Plays a tape.

PROGRAM Press to confirm the programmed timer and ON/OFF timer.

RECORD Starts TV/VCR recording.

RESET Resets video functions to factory settings. Also used to reset the time counter.

REVERSE Rewinds the tape when the TV/VCR is stopped. Also searches the picture in reverse during playback.

SKIP/SEARCH During playback, press to advance from 30 seconds up to 3 minutes.

SLEEP Sets TV/VCR to automatically turn off. Each time you press SLEEP, the clock will count down 10 minutes, starting at 120 minutes. Continue to press SLEEP until you reach 0 to cancel.

SLOW Press in playback mode to play tape in slow motion.

SOUND Displays *MONO* on-screen.

SPEED (Tape Speed) Selects a recording speed (SLP or SP).

STOP Stops functions such as record, play, rewind, fast forward, and pause.

TIMER Used to set TV/VCR to start recording at a preset time.

TRACKING + and - (up and down) Allows the manual reduction of streaks which may appear on the picture during regular or slow-motion playback. Reduces picture “jitter” during stop-action (paused) playback.

TV/VCR Switches between TV mode and VCR mode.

VOL (up and down) buttons Decrease or increase the TV/VCR volume.

(This page intentionally left blank)

Using the TV/VCR's Features

Chapter Overview:

- V-Chip
- Recording Features
- Picture Search Options
- Tracking
- Time Counter
- Channel Banner
- Sleep Timer
- Using Closed Captioning

Changing Entertainment. Again.



Using the TV/VCR's Features

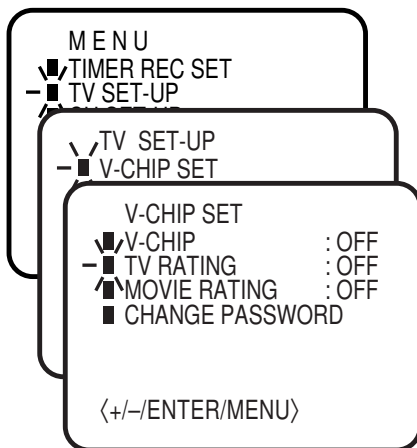

V-Chip

The *V-CHIP SET* menu allows you to program your TV/VCR so that children cannot see certain programs. The first three choices in the *V-CHIP SET* menu involve software inside your TV/VCR (referred to as V-Chip) which allows you to turn on V-Chip, block TV programs and movies based on violence, sex, or other content you may believe children should not view. In other words, it lets you program your TV/VCR so it won't display certain programs.

Once you block programs, you or other adults can unblock programs by entering a password.

By default, the software inside your TV is turned "off," so if you don't want to use this feature, you can just ignore it.

How V-Chip Works

When turned "on," the V-Chip software reads a code that most broadcasters send with programs. That code tells the software the program's age-based rating (TV-MA, TV-14, etc.) and content themes [Violence (V), Adult Language (L), etc.]. If you have blocked the rating and/or content themes that the program contains, the screen will be blue when you tune to that particular channel.

Broadcasters are not required to provide content themes, so programs received with no content themes will only be blocked if you block their age-based rating. The TV age-based ratings and content themes you can block are listed in the table on the next page.

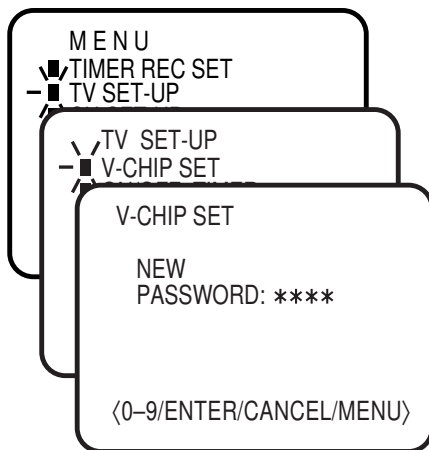

Setting the Password

The first step of the V-Chip setup is to set a password.

1. Press MENU on the remote (the *MENU* appears).
2. Select *TV SET-UP*, then press ENTER.
3. Select *V-CHIP SET*, then press ENTER.
4. Enter a password using the number buttons on your remote control, then press ENTER. When you enter the numbers, "*" appears on the screen.
5. Once you've entered a password, enter the same password again for confirmation. If you have entered the password correctly, the *V-CHIP SET* menu appears.

Using the TV/VCR's Features

Age-Based Rating	Description and Content Themes for Age-Based Ratings
TV-MA	Mature Audience Only. Specifically designed to be viewed by adults and may be unsuitable for children under 17. It contains one or more of the following content themes: crude indecent language (L), explicit sexual activity (S), or graphic violence (V).
TV-14	Parents Strongly Cautioned. Contains some material that many parents would find unsuitable for children under 14. Parents are strongly urged to exercise greater care in monitoring this program and are cautioned against letting children under the age of 14 watch unattended. This program contains one or more of the following content themes: intensely suggestive dialogue (D), strong coarse language (L), intense sexual situations (S), or intense violence (V).
TV-PG	Parental Guidance Suggested. Contains material that parents may find unsuitable for younger children. Many parents may want to watch it with their younger children. The program contains one or more of the following content themes: some suggestive dialogue (D), infrequent coarse language (L), some sexual situations (S), or moderate violence (V).
TV-G	General Audience. Most parents would find this program suitable for all ages. It contains little or no sexual dialogue (D) or situations (S), no strong language (L), and little or no violence (V).
TV-Y7	Directed to Children 7 years and older. Designed for children ages 7 and above. It may be more appropriate for children who have acquired the developmental skills needed to distinguish between make-believe and reality. Themes and elements in this program may include mild fantasy violence (FV) or comedic violence, or may frighten children under the age of 7.
TV-Y	All Children. Themes and elements in this program are designed for a young audience, including children from ages 2-6. It is not expected to frighten younger children.

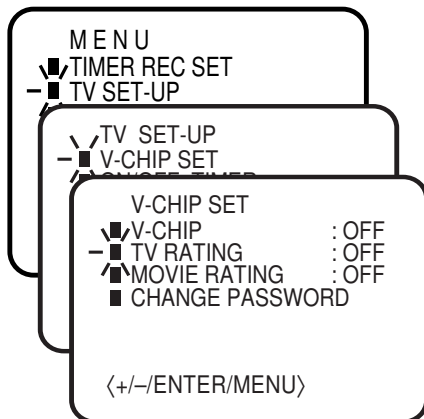

V-Chip TV Rating

The *V-Chip TV Rating* lets you decide which TV programs can and cannot be viewed.

To set TV programming limits:

1. Press MENU on the remote (the *MENU* appears).
2. Select *TV SET-UP*, then press ENTER.
3. Select *V-CHIP SET*, then press ENTER.
4. Enter your password using the number buttons on your remote control, then press ENTER (the *V-CHIP SET* menu appears).
5. Select *TV RATING*, then press ENTER.
6. Press the up or down arrow button to display the lowest rating you don't want the child to watch. For example, if you would want your child to watch TV-G and lower, select TV-PG.
7. Press ENTER to confirm the rating you have chosen.
8. Press the MENU button until the *MENU* screen disappears.

Note: If you are viewing a TV-PG program and you have blocked the TV-PG Rating, the screen turns blue.

Using the TV/VCR's Features

Content Themes	
D	Sexually explicit dialogue
L	Adult language
S	Sexual situations
V	Violence
FV	Fantasy Violence
TV-Y	All Children

Blocking Specific Content Themes

You can block programs based on their content. (Content is represented by the D, L, S, V, FV and TV-Y on your screen. See the beginning of this section for details.) When you block a content theme for a particular rating, you automatically block that content theme for higher rated programs as well.

For example, if you do not want your child to watch programs that have adult language (L) rated TV-PG or higher, then you could block out all programming TV-PG and above containing adult language.

To block program content:

1. Determine the lowest level of content you don't want the child to watch.
2. Press MENU on the remote (the *MENU* appears).
3. Select *TV SET-UP*, then press ENTER.
4. Select *V-CHIP SET*, then press ENTER.
5. Enter your password, then press ENTER (the *V-CHIP SET* menu appears).
6. Select *TV RATING*. If you have selected a rating limit that contains content you can block, the screen displays *Call to Set Contents*.
7. Press CALL on the remote (the *RATING SET* screen appears).
8. Press the down arrow to select the content you want to block. Press ENTER to turn ON the content.
9. Press the MENU button until the *MENU* screen disappears.

Notes: Broadcasters are not required to provide content themes or age-based ratings. Programs received with no content themes will only be blocked if you block their age-based rating.

You must remember to turn on V-CHIP for rating limits to take effect.

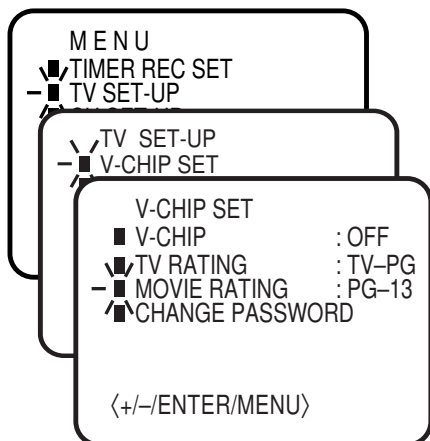

V-Chip Movie Rating

You set movie rating limits by blocking movies rated above a specified level.

To access the *MOVIE RATING* menu:

1. Press MENU on the remote (the *MENU* appears).
2. Select *TV SET-UP*, then press ENTER.
3. Select *V-CHIP SET*, then press ENTER.
4. Enter your password, then press ENTER (the *V-CHIP SET* menu appears).
5. Select *MOVIE RATING*, then press ENTER.
6. Press the up or down arrow button to display the lowest rating you don't want the child to watch. (In the example, you would want to select PG-13 since the highest rating you want the child to watch is PG).
7. Press ENTER to confirm the rating you have chosen.
8. Press the MENU button until the *MENU* screen disappears.

Using the TV/VCR's Features

Recording Features

The VCR provides several different ways to record programs from the TV. The following pages explain how to use the types of recording feature.

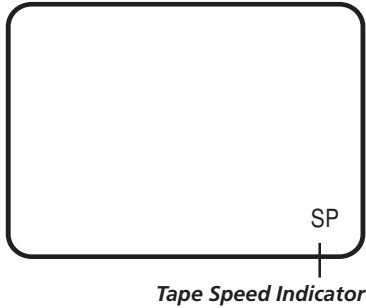

Recording Speeds

Press SPEED to select a recording speed.

- **SP** (Standard Play) gives the best quality recording; consequently, fewer programs can be recorded on the tape. Most pre-recorded, rental tapes are recorded in SP.
- **SLP** (Super Long Play) gives three times the recording time of tapes recorded in SP. Special effects such as pause, slow motion, picture search, and frame advance work in this speed.

	Recording Time	
Cassette	SP	SLP
T-120	2 hours	6 hours
T-160	2 hrs 40 min	8 hours

Recording Pause

This feature allows you to prevent recording short passages of unwanted material.

Press PAUSE during recording to temporarily stop and start recording. While the tape is paused, the RECORD indicator on the front panel will flash. The TV/VCR will automatically switch from pause to stop after a few minutes to prevent tape wear.

Types of Recording

Your TV/VCR provides four ways to record programs:

- **Recording** allows you to press one button to record a program.
- **One-Touch Recording (OTR)** allows recording to start while a program is being watched. This feature automatically stops recording after a designated period of time.
- **Timer Recording** program the VCR for a daily, weekly, or one time recording which will automatically start and stop at the times you set.
- **Copying and Editing Tapes** allows you to record from another VCR or camcorder.

One-Touch Recording (OTR)

Use OTR to quickly record the remaining portion of a program being watched. OTR is a great way to capture the end of a sporting event that has run into overtime or a live broadcast that runs long.

OTR works in 30-minute increments. You can capture the last 30, 60, 90, etc. minutes of programming (depending on the length of your tape, up to five hours).

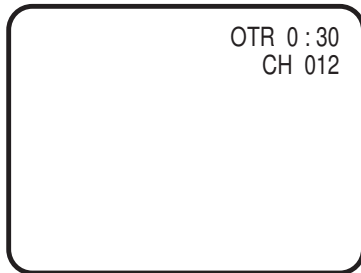

Each time you press RECORD, the recording time increases 30 minutes.

To Activate OTR:

1. Insert a tape with the safety tab in place into the TV/VCR. The TV/VCR will turn on.
 2. Press the SPEED button on the remote control to select the desired tape speed.
 3. Press the number buttons to enter the channel to be recorded.
 4. Repeatedly press the RECORD button to begin recording and to set the duration.
- Each press of RECORD adds 30 minutes of recording time.
 - To stop capturing OTR, press the STOP button.
 - The RECORD indicator will light during OTR.

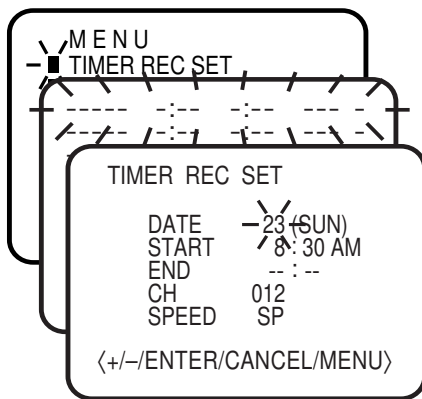

Timer Recording

Timer recording allows you to program the TV/VCR to record up to eight different programs. This is useful if you plan on being away from home for a long period of time. Before setting the timer, make sure that the clock is set correctly.

To set a timer recording:

1. Insert a tape with the safety tab in place into the TV/VCR. The TV/VCR will turn on.
2. Press MENU to display the *MENU*.
3. Select *TIMER REC SET*, then press ENTER.
4. Press the up or down arrow button to select the first program entry, then press ENTER (the *TIMER REC SET* menu appears).
5. Press the up or down arrow button to enter the correct date. Press ENTER to select the date.
6. Repeat step 5 to enter the information for each line.

The information you need to set includes the channel number (as well as L1, rear AUDIO/VIDEO jacks, or L2, front AUDIO/VIDEO jacks, if recording from the input jacks), start and end times (including AM or PM), and the tape speed.

(Steps continued on next page)

Using the TV/VCR's Features

7. Review the information to make sure it is correct, and then press ENTER to save. If you have made a mistake press CANCEL until the item you want to change is selected, then use the up or down arrow button to enter the correct information.
8. Repeat steps 4-7 for additional programs.
9. Press the TIMER button (the T REC indicator on the TV/VCR's front panel lights). To cancel timer recording press the TIMER button again (the T REC indicator goes out).

Note: *The VCR cannot be used while the T REC indicator is lit. If you want to use the VCR, press the TIMER button to deactivate.*

Copying and Editing Tapes

Use another VCR or camcorder as the playback VCR and the TV/VCR as the recording VCR.

Note: *The unauthorized recording of television programs and other materials may infringe upon the rights of others.*

1. Insert a tape with the safety tab in place into the TV/VCR. The TV/VCR will turn on.
2. Press the INPUT button to tune the TV/VCR to the AUDIO/VIDEO input jacks on the back of the TV/VCR. LINE 1 appears on-screen. Press the INPUT button again to tune the TV/VCR to the AUDIO/VIDEO input jacks on the front of the TV/VCR. LINE 2 appears on-screen.
3. Insert the tape you want to copy into the playback VCR or camcorder.
4. Start the playback VCR or camcorder playing. If the tape was not recorded on the playback VCR, streaks may appear and you may need to adjust the tracking. When you reach the place you want to begin copying, place the playback VCR or camcorder in play pause.
5. Press RECORD and PLAY simultaneously on the TV/VCR, then press PAUSE.
6. Press PAUSE on both the VCR or camcorder and the TV/VCR's remote at the same time to begin copying the tape.
7. Edit segments that you don't want to copy by pressing PAUSE on the TV/VCR's remote to pause the tape. Then, locate the next segment you want to copy on the playback VCR or camcorder by using FORWARD, REVERSE, or PLAY. Press PAUSE on the playback VCR or camcorder. Press PAUSE at the same time on both the VCR or camcorder and the TV/VCR's remote to resume copying.
8. Press STOP on both the VCR or camcorder and the TV/VCR's remote when you're finished.

Picture Search Options

The most basic way to search during playback is using the FORWARD or REVERSE buttons. This section contains several other options available for searching a tape.

Tape Speed	Speed Search Times	
	Press Once	Press Twice
SP	3X	5X
LP	7X	9X
SLP	9X	15X

Speed Search

Speed search allows you to advance or reverse the tape at an increased speed by pressing the FORWARD or REVERSE button twice. See the speed search times for each tape speed. Press PLAY to return to normal viewing speed.

Skip Search

Each time you press SKIP-SEARCH during playback the tape advances 30 seconds. You can press the button up to six times consecutively to move 180 seconds (3 minutes) ahead.

Tracking

Your TV/VCR has automatic tracking which removes streaks and “noise” from the picture. Automatic tracking is activated when you insert a tape or turn on the VCR. Occasionally you may need to manually adjust tracking, especially if the tape was recorded on a different VCR. Use the TRACKING +/- buttons to remove streaks and noise. You can also use tracking when pausing a tape to reduce the noise of the stilled picture.

When manually adjusting the picture, automatic tracking is turned off. To turn automatic tracking back on press the AUTO TRACK button.

Tracking has no effect when recording— only during playback.

Using the TV/VCR's Features

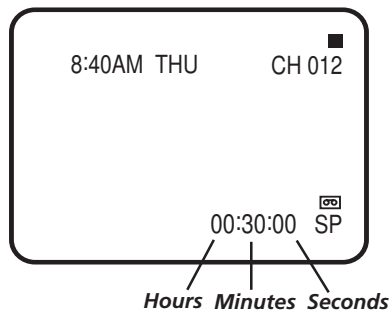

Time Counter

The time counter shows the actual time used in recording or playing back a tape. The time counter helps locate the beginning or end of recorded events. It resets to 00:00:00 whenever a tape is ejected from the TV/VCR.



For example, if you record a 30-minute program at the beginning of a tape, rewind it, and then want to go to the end of the first program to start another recording:

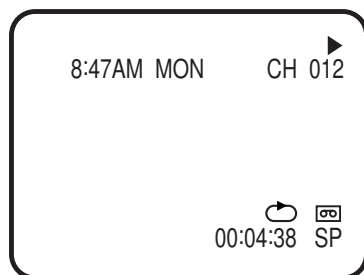





1. Press the CALL button to display the time counter.
2. Press the RESET button to reset the time counter to 00:00:00.
3. Press FORWARD to advance a tape until the time counter reads 00:30:00.
4. Press STOP. This is the approximate end of a 30-minute program (you may want to press PLAY to verify). When the tape is cued correctly, you can begin recording.
5. Press the CALL button to remove the time counter from the screen and return to the normal display mode.



Channel Banner

There are several indicators that might appear when you press the CALL button. This display is called the Channel Banner. The following list describes the items on the Channel Banner screen (left to right and top to bottom).

-  Displayed when a tape is playing. This symbol changes depending what playback mode you are in. (See Playback Mode symbols on next page).
- 8:47 AM** Displays the current time.
- MON** Displays the current day.
- CH 012** Displays the current channel or input channel.
-  Displayed when Auto Repeat has been set.
-  Displayed when a cassette is loaded in the VCR.
- 00:04:38** Displays the amount of time the tape has played.
- SP** Displays the tape speed.

Playback Mode Symbols	Explanation
	Tape is rewinding.
	Tape is advancing.
	Tape is ejecting.
	TV/VCR is recording.
	Tape is paused.
	Tape is stopped.

Sleep Timer

The sleep timer allows you to set an amount of time you want to give before the TV/VCR shuts itself off. Each press of the SLEEP button will count down 10 minutes on the clock, starting at 120 minutes. After the sleep timer is set, the screen will display the time every ten minutes to remind you the sleep timer is operating. To display the sleep timer momentarily, press SLEEP and the remaining time will be shown. To cancel the sleep timer, press SLEEP repeatedly until the display turns to 0.

Using Closed Captioning

Many programs are encoded with closed-captioning information, which lets you display the audio portion of a program as text on the TV screen.

Closed captioning is not available on all channels at all times. Only specific programs encoded with closed-captioning information are applicable. Check your TV/VCR program listings for CC (closed caption) broadcasts.

To use closed captioning, press the CAPTION button on the remote. Press once to view Caption Channel 1, twice to view Caption Channel 2, and again to view Full Screen Text.

Caption Channel 1 Displays the full translation of the primary language in your area.

Caption Channel 2 May be used as a second source for secondary languages.

Text Display on-screen box containing the text of general information not necessarily related to the program being watched.

Note: *The Text modes cover nearly half of the picture on-screen to display the closed-captioned text.*

(This page intentionally left blank)

Using the TV/VCR's Menu System

Chapter Overview:

- How to Use the TV/VCR's Menu System
- Setting the On/Off Timer
- Picture Menu
- System Set-up Menu
- Additional Features in the Menu

Changing Entertainment. Again.



Using the TV/VCR's Menu System

How to Use Your TV/VCR's Menu System

You use the buttons on the remote to access the menu system and make changes to the settings.

The following pages explain how to use the different types of menus to adjust the features of your TV/VCR.

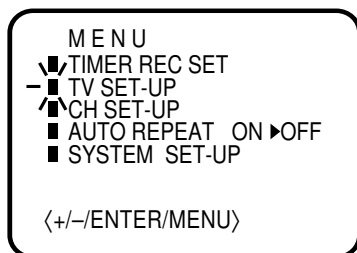

Menus

The first menu is called the MENU. Press MENU on the remote to bring up the MENU.

Menus take you to another menu or a control panel. To select a choice in a menu:

- Press the up or down arrow button to select a menu item. Press the ENTER button to activate the selection.

Exiting a menu

To exit a menu:

- Press MENU on the remote until the *MENU* screen disappears.

Setting the On/Off Timer

The *ON/OFF TIMER* menu lets you set a timer to automatically turn the TV/VCR on and off automatically.

Note: When you set the *ON TIMER* you must set the *OFF TIMER* as well or the TV/VCR will automatically turn off approximately one hour later after the TV/VCR has turned on.

To set the ON TIMER:

1. Press MENU to display the *MENU*.
2. Select *TV SET-UP*, then press ENTER.
3. Select *ON/OFF TIMER*, then press ENTER.
4. Select *ON TIMER*, then press ENTER to begin setting the timer.
5. Press the up or down arrow button to set the desired hour. Press ENTER to select the hour (the AM/PM setting will change as well).
6. Repeat step 4 to enter the desired minute, channel and day of the week.
7. Press the up or down arrow button to select the *SET* mode to set the *ON TIMER*, then press ENTER.
8. Press MENU until the *MENU* screen disappears.

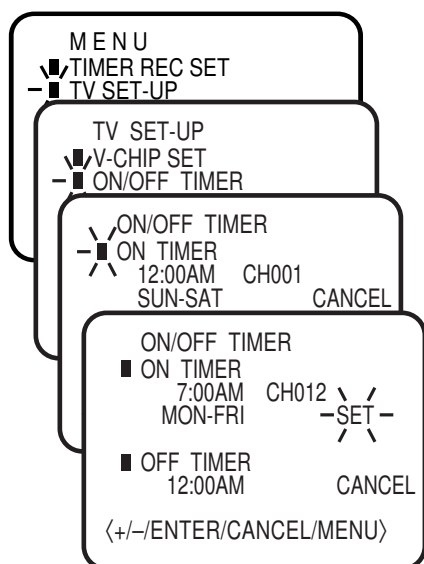

Using the TV/VCR's Menu System

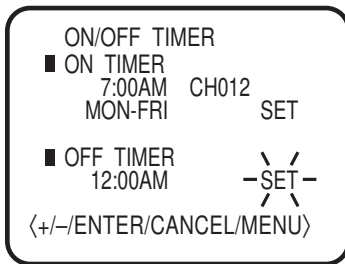

To set the OFF TIMER:

Follow steps 1-3 of setting the ON TIMER.

1. Select *OFF TIMER*, then press ENTER to begin setting the timer.
2. Press the up or down arrow button to set the desired hour. Press ENTER to select the hour (the AM/PM setting will change as well).
3. Press the up or down arrow button to set the desired minute, then press ENTER to select the minute.
4. Press the up or down arrow button to select the *SET* mode to set the *OFF TIMER*, then press MENU until the *MENU* screen disappears.

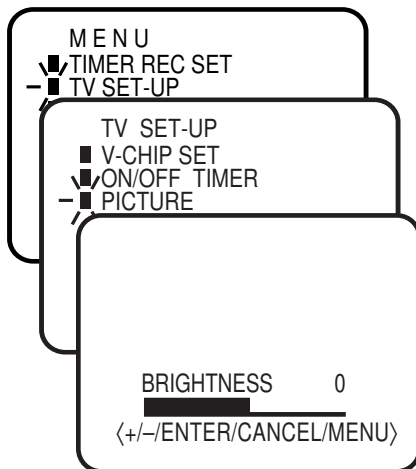

Picture Menu

The *PICTURE* menu has five slider controls for adjusting the way the picture looks.

Brightness Adjusts the brightness of the picture.

Contrast Adjusts the difference between the light and dark areas of the picture.

Color Adjusts the richness of the color.

Tint Adjusts the balance between the red and green levels.

Sharpness Adjusts the sharpness of the picture.

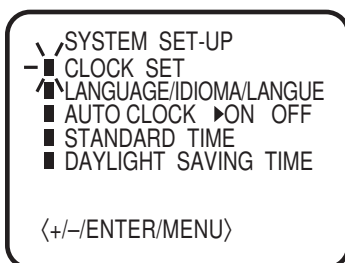

System Set-up Menu

Clock Set Allows you enter the current month, day, year and time manually. The on-screen directions guide you through the steps needed to set the clock.

Language/Idioma/Langue Displays a control panel that lets you select the TV/VCR's on-screen language display. See Chapter 1 to set the language.

Auto Clock Set Sets the TV/VCR's time automatically.

Standard Time Displays a control panel that lets you select the Standard Time zone. See Chapter 1 to set the time zone.

Daylight Saving Time Displays a control panel that lets you set the Daylight Saving Time. See Chapter 1 to set the Daylight Saving Time.

Using the TV/VCR's Menu System

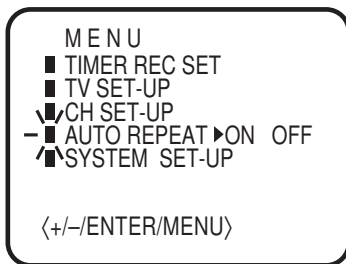

Additional Features in the Menu

Auto Repeat Feature This feature tells the TV/VCR to play a tape continuously. The TV/VCR will play the tape repeatedly until the repeat mode is canceled.

1. Press MENU to display the *MENU*.
2. Select *AUTO REPEAT*.
3. Press ENTER to select the *ON* position.
4. Press MENU until the *MENU* screen disappears.

To Cancel Auto Repeat

Follow steps 1 and 2, then press ENTER to select the *OFF* position.

Other Information

Chapter Overview:

- Troubleshooting
- Care and Cleaning
- Front Panel
- Limited Warranty
- Accessory Order Form
- Index

Changing Entertainment. Again.



Troubleshooting

Most problems you encounter with your TV/VCR you can correct by consulting the Troubleshooting list that follows.

General TV/VCR Problems

TV/VCR won't turn on

- Press the ON•OFF button to turn on the TV/VCR.
- Make sure the TV/VCR is plugged in.
- Check the wall receptacle (or extension cord) to make sure it is “live” by plugging in something else.
- Something might be wrong with your remote control. Press the POWER button on the front of the TV/VCR. If the TV turns on, go to page 36 for remote control solutions.

Controls don't work

- Unplug the TV/VCR for two minutes and then plug it back in. Turn the TV on and try again.

TV/VCR turns off unexpectedly

- Sleep timer or the On/Off timer may have been activated. Go to page 27 or 30 for instructions.
- Electronic protection circuit may have been activated because of a power surge. Wait 30 seconds and then turn the TV/VCR on again. If this happens frequently, the voltage in your house may be abnormally high or low.

TV/VCR turns on unexpectedly

- On/Off timer may have been activated. Go to page 30 for instructions.

Blank screen

- Try another channel.
- Check picture adjustments. Go to page 31 for instructions.
- Make sure the line input is not selected. Repeatedly press INPUT on the remote to switch between audio/video input jacks and tuner.

No sound, picture okay

- Press the volume up to increase the sound.
- Maybe sound is muted. Press the volume up button to restore sound.

No picture, no sound but TV is on

- Maybe the TV/CATV setting is set to the wrong position. Go to page 11 for instructions.
- The channel might be empty — change channels.

Sound okay, picture poor

- Make sure all of the cables are firmly connected to the jacks.
- Try adjusting sharpness function to improve weak signals. Go to page 31 for instructions.

Can't select certain channel

- Channel may be blocked in the *V-CHIP SET* menu.
- If using the VCR, make sure the TV/VCR is in the correct mode (press the TV button).

Clock is wrong

- Power interruption. Need to reset the clock. Go to page 10 for more information.
- Clock was not set accurately (check AM/PM and date). Go to page 10 for more information.

Auto channel search not searching properly

- Make sure all of the cables are firmly connected to the jacks.
- Signal type may not be set properly. If you have cable, make sure the cable type is chosen. Go to page 10 for instructions.

Black box appears on the screen

- Closed-captioning might be on. Check the *Closed-Caption Display*. Go to page 27 for more instructions.

Troubleshooting

Closed captions not appearing on screen

- Closed caption might not be set to on. Go to page 27 for more information.
- Station might not be broadcasting closed caption.

VCR Playback Problems

Tape plays continuously

- Auto repeat might be turned on. Go to page 32 for instructions.

Tape won't insert or eject

- Make sure you insert the tape with the window facing up and safety tab facing out.
- When removing a tape, make sure the TV/VCR is connected to a working outlet.
- Turn off the TV/VCR, then on before trying to insert or remove tape.

Tape won't play or record

- Make sure a tape has been inserted.
- Eject and reinsert tape.
- The tape might be broken — try another tape.
- Check to see if the safety tab has been removed. If it has, the TV/VCR will not record.
- The TV/VCR might be in pause mode. Press PAUSE on the remote to return the tape to play mode.

Timer counter not working

- Press CALL on remote to display the time counter on screen. Go to page 26 for more information.
- The timer counter will not advance during unrecorded portions of tape.
- You have rewound the tape farther back than a counter reading of 00:00:00. A minus (-) will appear if this has occurred.

Snow or streaks in picture or no picture during tape playback

- Check tape- it may be worn out or of poor quality.
- Some snow/streaks are normal during search, pause, and slow-motion playback.
- Might need to adjust the tracking. Go to page 25 for instructions.

TV/VCR makes noise when stopped

- TV/VCR is removing tape from heads, which is normal. The head cylinder inside the TV/VCR will continue to rotate for a few minutes after you put the VCR in stop mode.

VCR Recording Problems

T REC indicator on front of TV/VCR is flashing

- There might have been a power interruption. Check the clock for time and date setting. Go to page 10 for more information.

Cannot record one program while watching a different program

- The TV/VCR only has one tuner. Only one program can be watched and recorded at the same time.

Manual timer recording didn't work

- Program entered incorrectly. Go to page 23 for instructions.
- If the TV/VCR is connected to a cable box, the cable box was not turned on and tuned to correct channel at time recording was to begin.
- There might have been a power interruption. If so, the T REC indicator will flash on front of the TV/VCR.
- Check to see if the TV/VCR's time and date were set correctly. Go to page 10 for more information.
- Program exceeded tape's length or tape was not rewound beforehand.
- No tape in TV/VCR or tape without a safety tab inserted.

Other Information

The Remote Control Doesn't Work

- Something might be between the remote and the remote sensor on the component. Make sure there is a clear path.
- Maybe the remote isn't aimed directly at the TV/VCR.
- Maybe batteries in remote are weak, dead or installed incorrectly. Put new batteries in the remote. (Note, if you remove the batteries, you may have to reprogram the remote to operate other components.)
- You might need to drain the remote's microprocessor: remove batteries and press the number 1 button for at least 60 seconds. Release the 1 button, replace the batteries, and (if necessary) program the remote again.

Problems with V-Chip

The rating limits don't work

- You must turn on the settings. Go to the *MENU* (press MENU on your remote), select *V-CHIP SET*, select *V-CHIP "ON"*.

I don't remember my password

- If you forget your password, simultaneously press VOLUME down on the TV/VCR front panel and the 0 number button on the remote for a few seconds. This resets the password and you can enter a new one.

Care and Cleaning

CAUTION: Turn OFF your TV/VCR before cleaning.

You can clean the TV/VCR as required, using a soft lint-free cloth. Be sure to occasionally dust the ventilation slots in the cabinet to help assure adequate ventilation.

The TV's screen may be cleaned with a soft, lint-free cloth as well. Take care not to scratch or mar the screen. If necessary, you may use a cloth dampened with warm water. Never use strong cleaning agents, such as ammonia-based cleaners, or abrasive powder. These types of cleaners will damage the TV.

While cleaning do not spray liquid directly on the screen, or allow liquid to run down the screen and inside the TV/VCR. Also, avoid placing drinks or vases with water on top of the TV/VCR. This could increase the risk of fire or shock hazard or damage to the TV/VCR.

Caution: Using video games or any external accessory with fixed images for extended periods of time can cause them to be permanently imprinted on the picture tube (or projection TV picture tubes). ALSO, some network/program logos, phone numbers, etc. may cause similar damage. This damage is not covered by your warranty.

Front Panel

If you can't find your remote control you can use the buttons on your TV/VCR to operate many of the TV/VCR's features.

POWER Turns the TV/VCR on or off.

RECORD Indicator Lights when the One-Touch recording has been set.

T REC (Timer Record) Indicator Lights when a timer program has been set and a tape with the safety tab is in the TV/VCR. Also flashes when there has been a power interruption.

POWER Indicator Lights when the TV/VCR is on.

HEADPHONE Connect headphones (not supplied) to this jack.

VOL v Decreases the volume.

VOL ^ Increases the volume.

CH v Scans down through the current channel list.

CH ^ Scans up through the current channel list.

STOP/EJECT Stops normal functions such as record, play, rewind, fast-forward, or pause. Press when a tape is stopped to eject the cassette.

Remote Sensor Receives signals from the remote. Aim remote at this sensor with no objects between them.

PLAY Press once to begin playback of a tape.

REW (Rewind) Rewinds the tape when the TV/VCR is stopped. Searches the picture in reverse during playback.

FWD (Fast Forward) Fast forwards the tape when the VCR is stopped. Searches the picture forward during playback.

RECORD Press to start TV/VCR recording. Pressing this button repeatedly will record a program in 30 minute increments, up to five hours.

VIDEO IN Jack Receives video signals from another component, like a VCR or camcorder when it is connected to this jack. To select this front panel jack, press INPUT until *LINE 2* is displayed on-screen.

AUDIO IN Jack Receives audio signals from another component, like a VCR or camcorder when it is connected to this jack. To select this front panel jack, press INPUT until *LINE 2* is displayed on-screen.

RCA TV/VCR Limited Warranty

What your warranty covers:

- Defects in material or workmanship.

For how long after your purchase:

- 90 days from date of purchase for labor charges.
- One year from date of purchase for parts.
- Two years from date of purchase for picture tube.

The warranty period for rental units begins with the first rental or 45 days from date of shipment to the rental firm whichever comes first.

What we will do:

- Pay any Authorized RCA VCR Service Center the labor charges to repair your TV/VCR.
- Pay any Authorized RCA VCR Service Center for the new or, at our option, rebuilt replacement parts and picture tube required to repair your TV/VCR.

How you get service:

- For screen sizes of 26" and smaller: Take your RCA TV/VCR to any Authorized RCA VCR Service Center and pickup when repairs are complete.
- For screen sizes larger than 26": Request home or pick up, repair and return service from any Authorized RCA VCR Service Center, provided that your TV/VCR is located within the geographic territory covered by an Authorized RCA VCR Service Center. If not, you must take your TV/VCR to the Service Center location at your own expense, or pay for the cost the Service Center may charge to transport your unit to and from your home.
- To identify your nearest Authorized RCA Service Center, ask your dealer, look in the Yellow Pages, or call 1-800-336-1900.
- Proof of purchase in the form of a bill of sale or receipted invoice which is evidence that the product is within the warranty period must be presented to obtain warranty service. For rental firms, proof of first rental is also required.

Other Information

What your warranty does *not* cover:

- Customer instruction. (Your Owner's Manual describes how to install, adjust, and operate your television. Any additional information should be obtained from your dealer.)
- Installation and related adjustments.
- Signal reception problems not caused by your TV/VCR.
- Damage from misuse or neglect.
- Cleaning of audio/video heads.
- Batteries.
- A TV/VCR that has been modified or incorporated into other products or is used for institutional or other commercial purposes.
- Images burnt onto the screen.
- Acts of nature, such as but not limited to lightning damage.
- A TV/VCR purchased or serviced outside the U.S.A.

Product Registration:

- Please complete and mail the Product Registration Card packed with your set. It will make it easier to contact you should it ever be necessary. The return of the card is not required for warranty coverage.

Limitation of Warranty:

- **THE WARRANTY STATED ABOVE IS THE ONLY WARRANTY APPLICABLE TO THIS PRODUCT. ALL OTHER WARRANTIES, EXPRESS OR IMPLIED (INCLUDING ALL IMPLIED WARRANTIES OF MERCHANTABILITY OR FITNESS FOR A PARTICULAR PURPOSE) ARE HEREBY DISCLAIMED. NO VERBAL OR WRITTEN INFORMATION GIVEN BY THOMSON MULTIMEDIA INC., ITS AGENTS OR EMPLOYEES SHALL CREATE A WARRANTY OR IN ANY WAY INCREASE THE SCOPE OF THIS WARRANTY.**
- **REPAIR OR REPLACEMENT AS PROVIDED UNDER THIS WARRANTY IS THE EXCLUSIVE REMEDY OF THE CONSUMER. THOMSON MULTIMEDIA INC. SHALL NOT BE LIABLE FOR INCIDENTAL OR CONSEQUENTIAL DAMAGES RESULTING FROM THE USE OF THIS PRODUCT OR ARISING OUT OF ANY BREACH OF ANY EXPRESS OR IMPLIED WARRANTY ON THIS PRODUCT. THIS DISCLAIMER OF WARRANTIES AND LIMITED WARRANTY ARE GOVERNED BY THE LAWS OF THE STATE OF INDIANA. EXCEPT TO THE EXTENT PROHIBITED BY APPLICABLE LAW, ANY IMPLIED WARRANTY OF MERCHANTABILITY OR FITNESS FOR A PARTICULAR PURPOSE ON THIS PRODUCT IS LIMITED TO THE APPLICABLE WARRANTY PERIOD SET FORTH ABOVE.**

How state law relates to this warranty:

- Some states do not allow the exclusion nor limitation of incidental or consequential damages, or limitations on how long an implied warranty lasts, so the above limitations or exclusions may not apply to you.
- This warranty gives you specific legal rights, and you also may have other rights that vary from state to state.

If you purchased your product outside the United States:

- This warranty does not apply. Contact your dealer for warranty information.

Service calls which do not involve defective materials or workmanship are not covered by this warranty. Costs of such service calls are the sole responsibility of the purchaser.

Other Information

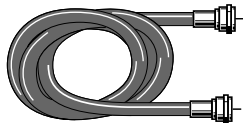

VH81 (3-ft)
VH82 (6-ft)

Screw-on Cable attaches to the round antenna connectors (called 75-ohm F-type) on the back of your TV/VCR. The ends screw onto the connectors for a secure connection.

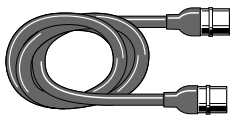

VH89 (6-ft)

Push-on Cable attaches to the round antenna connectors (called 75-ohm F-type) on the back of your TV/VCR. Ends push on for a quick connection.

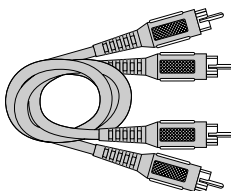

Gold-Tipped cable
VH83 (6-ft)

Monaural VCR Dubbing Cable Double cable that lets you connect the video and audio jacks of two VHS VCRs to duplicate tapes. Can also be used to connect a VCR to your TV/VCR. Cable is color-coded and shielded. Has RCA-type phono plugs on each end.

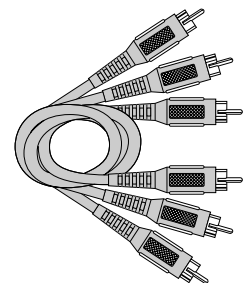

Gold-Tipped cable
VH84 (6-ft)

Stereo VCR Dubbing Cable Triple cable that lets you connect the VIDEO and AUDIO jacks of stereo components.

Accessory Order Form

Description	Part No.	Price	Qty
Screw-on antenna cable (3-ft)	VH81	\$3.95	
Screw-on antenna cable (6-ft)	VH82	\$4.95	
Push-on antenna cable (6-ft)	VH89	\$5.95	
Monaural VCR Dubbing Cable (6-ft)	VH83	\$5.95	
Stereo VCR Dubbing Cable (6-ft)	VH84	\$9.95	
2-way Signal Splitter	VH47	\$3.95	
Amplified Antenna	ANT200	\$49.95	
Antenna Mixer (not shown)	193984	\$11.15	
Remote Control (CRK76TY1)	253614	\$39.95	
Audio•Video Adapter (not shown)	228449	\$4.45	

Prices are subject to change without notice.

Total Merchandise \$ _____

Sales Tax \$ _____

We are required by law to collect the appropriate sales tax for each individual state, country, and locality to which the merchandise is being sent.

Shipping and Handling \$ 5.00

Total Amount Enclosed \$ _____

Use VISA, MasterCard, or Discover Card preferably.

Money order or check must be in U.S. currency only.

No COD or CASH.



Detach Here

All accessories are subject to availability. Where applicable, we will ship a superseding model.

Please complete other side also

Continued on next page.....

Other Information

Charge your order on your VISA, MasterCard, or Discover Card by filling in below

USE YOUR CREDIT CARD

IMPORTANT: Copy complete account number from your VISA card



--	--	--	--	--	--	--	--	--	--	--	--	--	--	--	--

My card expires:

--	--

 /

--	--

IMPORTANT: Copy complete account number from your MasterCard



--	--	--	--	--	--	--	--	--	--	--	--	--	--	--	--

Copy Number above your name on MasterCard:

--	--	--	--

 My card expires:

--	--

 /

--	--

IMPORTANT: Copy complete account number from your Discover Card



--	--	--	--	--	--	--	--	--	--	--	--	--	--	--	--

My card expires:

--	--

 /

--	--

AUTHORIZED SIGNATURE
 (Credit card order will not be processed without signature)

Print or type your name and address clearly.



A complete and correct order will save you days of waiting.

Name: _____

Street: _____

_____ Apt: _____

City: _____

State: _____ Zip: _____

Daytime phone number: _____

Detach Here 

Please make sure that both sides of this form have been filled out completely.

- Allow 4 weeks for delivery.
- All accessories are subject to availability.
- Prices are subject to change.

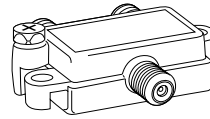

Splitter VH47

2-way Signal Splitter

Helps you connect a second TV or VCR.

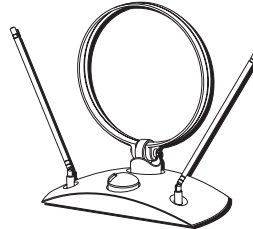

ANT200

Amplified Antenna

Allows you to quickly switch from the antenna signal to the cable or satellite signal without disconnecting the antenna.

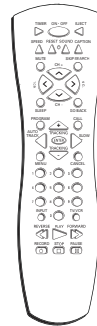

CRK76TY1

Remote Control

This is the remote control that came packed with your TV/VCR. Replacements or spares can be ordered as needed.

To Order

To place your order by phone, have your Visa, MasterCard or Discover Card ready and call the toll-free number listed below.

Use this number only to place an order for accessory items listed on this order form.

1-800-338-0376

To place your order by mail, detach and mail the completed order form with credit card information, money order or check in US currency (made payable to Thomson multimedia Inc.) to the following address:

Video Accessories
PO Box 8419
Ronks, PA 17573

A

Accessories 39
 Add/Remove Channels 12
 Age-Based Ratings 19
 Arrow buttons 14
 AUDIO jacks 8
 Auto
 Channel Memory 11
 repeat 32
 AUTO TRACK button 14
 Automatic
 rewind 13
 tracking 25

B

Back panel 8
 Basic
 recording 13
 Batteries for the remote 9
 Block
 Specific Content Themes 20
 Buttons, remote control 14

C

CALL button 14
 CANCEL button 14
 CAPTION button 14
 CH + button 14
 CH - button 14
 Channel
 Banner 26
 Cleaning the TV/VCR 36
 Clock
 set 10
 Closed Captioning 27
 Connection
 TV/VCR 7
 Content Themes 19
 Controls
 Front panel 36
 Copying tapes 24

D

Daylight Saving Time 11

E

Editing tapes 24
 EJECT button 14
 ENTER button 14

F

FORWARD button 14
 Front panel 36
 jacks 37

G

GO BACK button 14

I

INPUT button 14

J

Jacks
 back panel 8
 front panel 37

L

L.E.D. button 14
 Language 9

M

Menu
 On/Off Timer 30
 Picture 31
 System Set-up 31
 MENU button 14
 MUTE button 14

N

Number buttons 14

O

ON•OFF button 14
 On/Off Timer 30
 One-Touch Recording 23

P

PAUSE button 14
 Picture
 adjusting 31
 Menu 31
 Picture search options 25
 PLAY button 15
 PROGRAM button 15

R

Rating Limits
 movies 20
 TV 19
 RECORD button 15
 Recording
 Basic 13
 One-Touch 23
 pause 22
 speeds 22
 Timer 23

Remote

batteries 9
 buttons 14
 RESET button 15
 REVERSE button 15

S

Safety tab 13
 Search
 Skip 25
 Speed 25

Set

Off Timer 31
 On Timer 30
 One-Touch Recording 23
 Timer Recording 23

Setting

channels 11
 SKIP/SEARCH button 15
 SLEEP button 15
 Sleep Timer 27
 SLOW button 15
 SLP Speed 22
 SOUND button 15
 SP Speed 22

Speed

SLP 22
 SP 22
 SPEED button 15
 Speed Search
 LP 25
 SLP 25
 SP 25

STOP button 15

Stopping

One-Touch Recording 23
 Timer Recording 24
 System Set-up Menu 31

T

Time counter 26
 Time Zone 10
 TIMER button 15
 Timer Recording 23
 Tracking
 automatic 25
 manual 25
 TRACKING buttons 15
 Troubleshooting 34
 TV/VCR
 connection 7
 TV/VCR button 15
 TV/VCR setup 9
 Types of Recording 22

U

UHF/VHF jack 8

V

V-Chip 18
 Age Based Ratings 19
 Content Themes 19, 20
 Movie Rating 20
 Password 18
 TV Rating 19
 VIDEO jacks 8
 VOL + button 15
 VOL - button 15

W

Warranty 37

Visit the RCA web site at www.rca.com

Please do not send any products to the Indianapolis address listed in this manual or on the carton. This will only add delays in service for your product.

Thomson multimedia Inc.

**10330 North Meridian Street
Indianapolis, IN 46290**

©2001 Thomson multimedia Inc.

Trademark(s)® Registered

Marca(s) Registrada(s)

Printed in USA

TOCOM 15775840

5850401A 

01/08

