

550

MODELLI MODELS	MOMENTO LIFTING MOMENT	SBRACCIO ORIZZ. HORIZ. HYDRAULIC OUTREACH	PORTATA AL DISTRIBUTORE OIL FLOW TO THE CONTROL VALVE	SBRACCIO MAX. VERTICALE MAX VERTICAL REACH	PESO WEIGHT	PRESSIONE PRESSURE	INTERASSE STABILIZZATORI STANDARD APERTI DISTANCE BETWEEN CENTRES WITH OPENED OUTRIGGERS
	Tm.	m.	l.min	m.	Kg	bar	mm.
550A1	4.70	5.00	16	7.75	534	250	2970
550A2	4.45	6.45	16	9.15	569	250	2970
550A3	4.20	7.90	16	10.51	619	250	2970

Autocarro consigliato - Recommended truck - Camion conseille - Camion aconsejado
M.T.T. ton 6,5 - G.V.W. ton 6,5

STANDARD



370°
Angolo di rotazione
Slewing angle



130
Serbatoio olio
Oil Tank

STANDARD CE



Limitatore di momento
Overload device

Model	2.45m	3.65m	5.00m	6.45m	7.95m		
550A1 m Kg	1870	1285	945	620	450		
550A2 m Kg	1775	1185	860	680	450	350	
550A3 m Kg	1680	1100	790	615	510	320	230

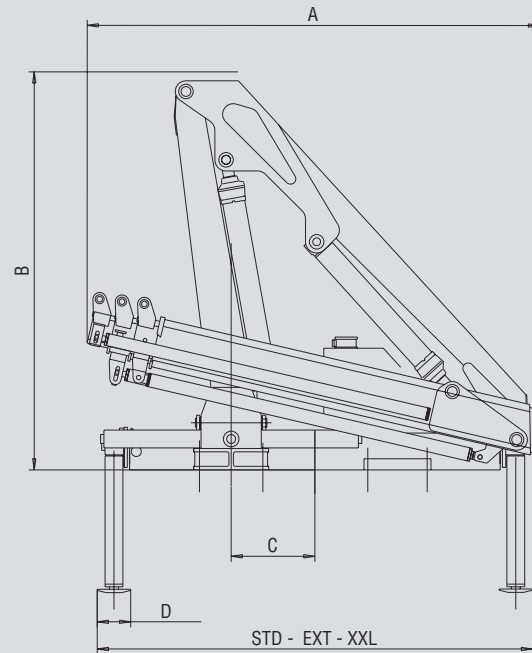

550	A	B	C	STD	EXT	XXL	D
550A1	1844	1780	375	1950	1950	2300	150
550A2	1939	1780	375	1950	1950	2300	150
550A3	2025	1780	375	1950	1950	2300	150

SPAZIO RICHiesto PER L'INSTALLAZIONE NECESSARY SPACE FOR INSTALLATION

550	STD	XXL	con attivazioni	STD	XXL
550A1	530	590	With extra function	650	710
550A2	530	590		650	710
550A3	640	700			

F.lli FERRARI CORPORATION S.p.A.

Via Pasubio, 3

42022 Boretto (RE) Italy

Tel. +39 0522/964921

Fax +39 0522/964405

E-mail: marketing@flliferrari.it

M.K.T. 5800100 03/04 3000



550

550

F.LLI FERRARI CORPORATION S.p.A.

FERRARI® 550



①

La gru F.Ili Ferrari mod. 550 racchiude in se caratteristiche tecniche e meccaniche di elevata qualità

- Acciai ad alto limite di snervamento
- Basamento e pignone colonna in fusione
- Struttura interamente sabbiata
- Bracci esagonali
- Sbracci fino a 7.9 m (9.41 con prolunga meccanica)
- Valvole di sicurezza flangiata
- Comandi bilaterali
- Limitatore di momento (CE)
- Stabilizzatori rotanti
- Pattini di scorrimento con ripresa gioco autoserrante
- Boccole autolubrificanti
- Raccorderia SAE J 1514I
- Gancio girevole
- Kit di montaggio compreso

Accessori

- Prolonghe meccaniche
- Stabilizzatori extraestendibili (3.410)
- Stabilizzatori superextraestendibili (4.800)
- Traverse supplementari
- Comandi supplementari attivati (solo A1-A2)
- Verricello idraulico
- Comando a distanza
- Utilizzo con attrezzo
- Dispositivo di controllo RLC

GB

The crane model 550 from F.Ili Ferrari has been projected and manufactured with high quality technical and mechanical characteristics

- Steel at high yielding edge
- Basement and column pinion by melding made
- Structure fully sandblasted
- Hexagonal booms
- Hydraulic outreach until 7.9 mt (9.41 with mechanical boom)
- Flanged valves
- Bilateral controls
- Load limiting device (CE)
- Turning outriggers
- Sliding pad with self-adjusting gap
- Self-tapping bushings
- SAE JIC 1514I fittings
- Turning hook
- Mounting kit included

Accessories

- Mechanical booms
- Extra wide outriggers (3.410)
- Super-extra wide outriggers (4.800)
- Extra beams
- Extra functions (A1 - A2)
- Hydraulic winch
- Remote control
- Use with special equipments
- Load radio checking device RLC

F

LA grue modèle 550 F.Ili Ferrari est conçue avec des caractéristiques techniques et mécaniques de plus haute qualité

- Acier à haut niveau de déformation plastique
- Embase et pignon colonne moulés
- Structure complètement sablée
- Rallonges hexagonales
- Portée Hydraulique jusqu'à 7.9 Mt (9.41 mt avec rallonges mécaniques)
- Vannes bridées
- Commandes bilatérales
- Limiteur de moment (CE)
- Béquilles tournantes
- Patins de coulissement auto enregistrables
- Douilles autolubrifiantes
- Raccords SAE-JIC 1514I
- Crochet tournant
- Kit de montage inclus

Accessoires

- Rallonges mécaniques
- Béquilles extra larges (3.410)
- Béquilles super extra larges (4.800)
- Poutres bâquilles supplémentaires
- Circuits supplémentaires activées (A1 - A2)
- Treuil hydraulique
- Commande à distance
- Utilisation avec accessoires
- Dispositif de contrôle de la charge RLC

D

Das Kranmodell 550 vom F.Ili Ferrari ist mit höchsten Qualität für technischen und mechanischen Eigenschaften projiziert und hergestellt worden

- Stahl am hohen einträglichen Rand
- Sockel und Zahnrad beim Schmelzen gemacht
- Struktur voll Sand gestrahlt
- Sechseckige Ausschube
- Hydraulischen Reichweiten bis 7.9 mt. (9.41 mt mit mechanischen Ausschube)
- Geflanscht Ventilen
- Zweiseitige Kontrollen
- Lasthaltventil (CE)
- Drehbar Abstützungen
- Gleitschuh mit Selbstnachsteller Spiel
- Selbstschmierende Buchsen
- SAE-JIC 1514I Anschlusse
- Schwenkbar Haken
- Einsatzbau eingeschlossen

Zubehöre

- Mechanische Ausschube
- Extra-weit Abstützungen (3.410)
- Super Extra-weit Abstützungen (4.800)
- Zusatzabstützungen
- Zusatzfunktionen (A1 - A2)
- Hydraulischer Winde
- Fernsteuerung
- Benutzung mit Zubehöre
- Gewichtskontrolle Vorrichtung RLC

SP

El modelo de la grúa 550 de F.Ili Ferrari se ha proyectado y fabricado con características técnicas y mecánicas de alta calidad

- Acero en el alto borde de rendimiento
- Piñón de la columna y basamento moldeados
- Estructura completamente arenada
- Prolongas hexagonales
- Alcances hidráulicos hasta mt. 7.9 (9.41 mt con prolongas mecánicas)
- Valvulas rebordeadas
- Mandos bilaterales
- Limitador de momento (CE)
- Patas giratorias
- Patín de deslizamiento con juego autoregular
- Casquillos autolubricantes
- Empalmes SAE-JIC 1514I
- Gancho giratorio
- Kit de montaje incluido

Accesorios

- Prolongas mecánicas
- Patas extra-largas (3.410)
- Patas super extra-largas (4.800)
- Patas adicionales
- Activaciones adicionales (A1 - A2)
- Cabrestante hidráulico
- Mando a distancia
- Utilización con accesorios
- Dispositivo de verificación de carga RLC

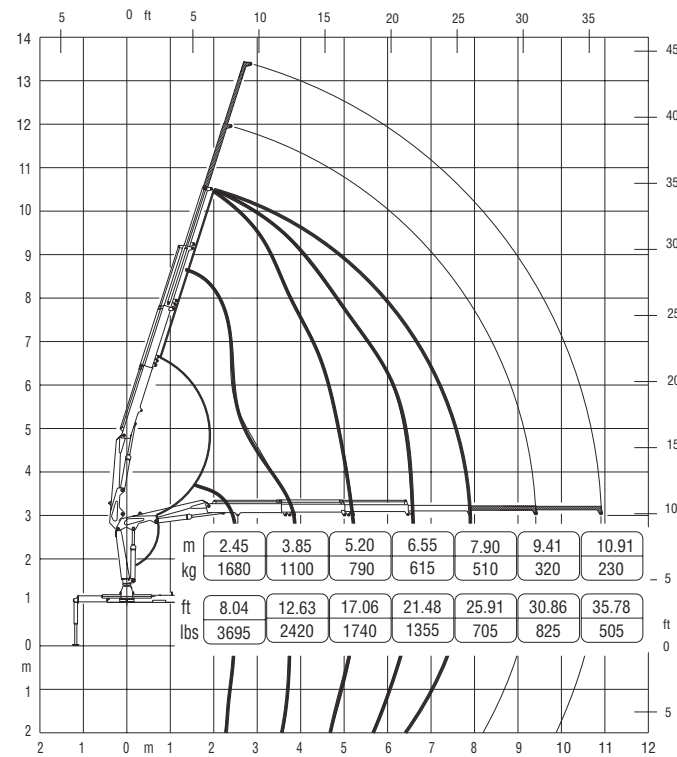

Questo dispositivo visualizza su un display collocato in prossimità dei comandi il carico applicato al gancio della gru, rendendo l'utilizzo delle prolunghe meccaniche sicuro secondo la normativa europea EN 12999.

This device shows the load at the hook on a display placed near the controls, making safe the use of the mechanical booms following the European rule EN 12999.

