



# BASIC ELECTRONICS TEST TEST INFORMATION PAMPHLET

## WHY DO AT&T AND ITS AFFILIATES TEST?

When individuals are being considered for our available job openings, they go through a selection process to measure their knowledge, skills and abilities to determine if they can perform the jobs in a satisfactory manner. It is to the advantage of both you, as a job candidate, and the company that only those who can perform at acceptable levels be placed on the job. Research has shown that tests provide accurate measures of people's knowledge, skills and abilities and, therefore, we use tests to help identify people best suited for our jobs.

## WHAT IS THE BASIC ELECTRONICS TEST?

The Basic Electronics Test is designed to measure your knowledge and ability to apply concepts, terms, and principles involved in working on or near electrical and electronic equipment. Although the test contains some factual questions, it emphasizes your understanding of the subject and your ability to apply what you know, not just your memory of facts or formulas.

Although there are no prerequisites for taking the Basic Electronics Test, if you have no prior training or work experience in basic electricity and electronics, you probably will not do well on the test.

The Basic Electronics Test consists of 60 multiple-choice questions. Each question has four possible answers to choose from. Some questions refer to figures containing circuit diagrams or other schematics. These will be provided to you. Total testing time is approximately 60 minutes. In some locations, the test is given on a PC using a mouse. A tutorial is provided before the test that provides instructions on how to select answers, move from question to question, and view figures/diagrams.

You will have to perform calculations, but you can use a calculator. You may bring a calculator that is silent, handheld, and battery operated. It cannot be solar or have alpha characters on the keypad. The calculator you bring should be able to perform the following functions: Addition, Subtraction, Multiplication, Division, Cosine, Power functions, Logarithmic functions, and Square Roots. A scientific calculator can perform these functions.

You will use formulas on the test, but you don't need to have them memorized. A reference screen on the PC contains all the formulas you might need. You can refer to it anytime your memory needs jogging.

The scoring of the Basic Electronics Test is based on the number of correct answers. There is no penalty for guessing, so it is to your advantage to try as many questions as possible. If you are unsure about the answer to a question, a careful guess should be made.

The Basic Electronics Test covers four main subject areas:

- DC Circuit Analysis
- AC Circuit Analysis
- Transmission Lines
- Fundamentals of Electronics

In addition, you need to know:

- Applied Math
- How to Use a Scientific Calculator

A brief description of each subject area is provided. If you know and understand these things and can apply what you know, you should do well on the test.

## **DC CIRCUIT ANALYSIS**

- Use Ohm's law to solve for E, I or R
- Understand the relationship of conductor size and length to resistance
- Use the power formula to solve for P, E or I
- Understand the relationships of efficiency, power input and power output in a circuit
- Calculate the total resistance of a series resistance circuit
- Calculate the total resistance of a parallel resistance circuit
- Simplify series-parallel resistance networks in order to determine the E, I, R or P across any network component using Kirchhoff's Law

## **AC CIRCUIT ANALYSIS**

- Understand the concept of a sine wave including phase, frequency, period and amplitude
- Understand the relationships among rms, peak, and peak-to-peak voltage in alternating current circuits and be able to solve for any of these using a formula provided
- Understand the concepts of capacitance and inductance
- Understand the relationship of capacitive and inductive reactance with frequency
- Recognize the symbols for reactance—capacitive and inductive
- Understand the E and I phase relationships in reactive (inductive or capacitive) circuits
- Understand the concepts of true power, apparent power, and power factor (PF) in a reactive circuit and be able to solve for any of these using a formula

## **TRANSMISSION LINES**

- Understand the concept of impedance matching and the effects of mismatch on the transfer of energy
- Understand how the primary constants (resistance, capacitance and inductance) of a transmission line affect the attenuation of a signal
- Understand the decibel concept and how it applies to signal transmission
- Convert from a power or voltage ratio to decibels and vice versa
- Convert from an absolute power or voltage value to decibels and vice versa
- Calculate attenuation over a transmission line using decibels (dB)
- Understand the purpose and function of various protective devices and recognize their schematic symbols

## **ELECTRONICS FUNDAMENTALS**

- Recognize various types of passive frequency filters and understand how they work
- Understand basic solid state theory of a diode
- Understand the concept of forward and reverse bias of a diode
- Understand the function of various diode types and their application in a circuit
- Recognize the electronic symbols for various diode types
- Understand basic transistor theory and the concept of gain in an amplifier
- Recognize the schematic symbols for various transistor types
- Understand the function of a transistor in a simple circuit
- Understand basic transistor biasing and stabilization concepts
- Understand how AC is converted to DC by rectification and filtering in a power supply
- Recognize the type of rectifier configurations—half-wave and full-wave rectification
- Understand the concept of power supply regulation and how transistors and diodes are used to perform this function
- Know how to trace signal flow in a simple circuit such as a power supply or amplifier
- Understand the basic functions of multimeters—both digital and analog
- Know how to use a multimeter to troubleshoot circuit components such as diodes, capacitors, inductors and resistors
- Know how to use a multimeter to find a short and open in a simple circuit
- Know how to use voltage multipliers (high-voltage probes) to extend a multimeter's range
- Know how to use current multipliers (current shunts) with a multimeter to extend its range
- Interpret multimeter readings when using a high-voltage probe by calculating the voltage drop across the probe (Ohm's law) based on the combined series resistance of the probe and multimeter input
- Interpret the multimeter reading when using a current shunt based on the voltage drop across the shunt and its resistance

## **APPLIED MATH**

- Add, subtract, multiply, and divide whole numbers and decimals
- Manipulate positive and negative numbers
- Manipulate powers of ten and logarithms
- Understand symbols for subunits of electrical quantities and be able to convert from one subunit to another (Examples: k = kilo = 1000,  $\mu$  = micro =  $10^{-6}$ )
- Solve equations given a formula such as Ohm's law
- Understand what *direct* and *inverse* relationships are

## **USE OF A SCIENTIFIC CALCULATOR**

- Use the proper key stroke sequence to apply a formula
- Store and recall values in memory
- Calculate using exponents, reciprocals, powers and roots
- Determine the log and  $\log^{-1}$  (anti-log) of a given ratio or value
- Determine the sin, cos,  $\sin^{-1}$  or  $\cos^{-1}$  of a given phase relationship

The following types of questions are on the test Basic Electronics Test.

- **Terms and Definitions** - These questions ask for the definition of a term, the name for a concept or device, or the characteristics of a component. For example:

Q: What is an amplifier?

A: *A device that makes sounds louder and signal levels greater*

Q: What device is used to convert direct current to alternating current?

A: *Oscillator*

Q: How does a digital meter's display differ from an analog meter's display?

A: *Shows digital (numeric) readout instead of a needle pointing to a mark on a fixed scale*

- **Relationships and Principles** - These questions ask how two concepts or measurements relate to each other. For example:

Q: Holding resistance constant, how does increasing current in a circuit affect voltage?

A: *Voltage increases*

Q: How would adding a 20- $\Omega$  resistor in parallel with a 100- $\Omega$  resistor change the reading on an ammeter?

A: *Current would increase*

- **Interpreting Facts** - A situation or problem will be described. You will be asked to explain what's happening or what's wrong. For example:

Q: When measuring DC voltage across a device with a multimeter, the meter indicates 0 volts. What is one possible explanation for this reading?

A: *Switch is open*

- **Calculating Circuit Values** - You'll be asked to figure out the amount or level of a measurement in a circuit, given other information about the circuit. For example:

Q: What is the resistance of a lamp which draws 120 mA when connected to a 12.6-V battery?

A: *105  $\Omega$*

- **How-To** - You'll be asked to how to perform a task. For example:

Q: How should a multimeter's leads be connected when measuring resistance?

A: *Connect the test leads to the terminals on the tested device*

## SELF-ASSESSMENT

This section contains a practice test of 25 questions that are similar to the questions on the real test. To find out how ready you are to take the real Basic Electronics Test:

1. Take the practice test.
2. Use the key on page 7 to score it.
3. Review the explanations, starting on page 7, for questions you missed or were unsure of.
4. Look up your score on page 13 to see how well you are likely to do on the real test.

### PRACTICE TEST INSTRUCTIONS

You will need this Study Guide, paper and pencil, and a calculator able to perform the following functions: Addition, Subtraction, Multiplication, Division, Cosine, Power functions, Logarithmic functions, and Square Roots. Read each question carefully. Use the Reference Sheet on page 8 to find the figures and formulas you will need. Pick the best answer for each question and write the letter of your answer on a piece of paper.

### PRACTICE TEST

1. Refer to Figure 1B. What is the expected power level at the input to the receiver?
  - a. 20 dBm
  - b. 30 dBm
  - c. 40 dBm
  - d. 50 dBm
2. Why is it important to maintain an impedance match from the source to the load when sending signals?
  - a. to reduce external noise
  - b. to keep the line balanced
  - c. to reduce reflected energy
  - d. to reduce attenuation
3. Which of the following is represented by the symbol  $X_L$ ?
  - a. impedance of a load
  - b. reactance of a coil
  - c. resonant frequency of a filter
  - d. output level of a source
4. One coulomb-per-second is equal to one:
  - a. watt
  - b. joule
  - c. volt
  - d. ampere

5. Refer to Figure 2. Which of the components is the symbol for a PNP bipolar transistor?
- A
  - C
  - D
  - G
6. The frequency of a signal is INVERSELY proportional to which of the following:
- period
  - amplitude
  - phase
  - power
7. The amount of useful output power provided by a device is 1.5 W. It is powered by a 48-V supply with 100 mA of current. How much power is wasted in heat?
- 1.5 W
  - 2.1 W
  - 3.3 W
  - 6.3 W
8. Refer to Figure 1D. A voltage level of 20 V is measured at the output of the power supply with no load attached. Which of the following is the probable cause?
- R1 shorted
  - C1 open
  - D1 shorted
  - D3 open
9. As the efficiency of a device DECREASES, which of the following will INCREASE?
- power output
  - amplifier gain
  - heat output
  - output impedance
10. What is the peak voltage of a sine wave that measures 220 VAC rms?
- 155 V
  - 169 V
  - 311 V
  - 440 V
11. A 1-mW signal is attenuated at the rate of 5 dB/1,000ft. What is the power level into a receiver that is 6,000 feet from the signal source?
- 5 dBm
  - 10 dBm
  - 20 dBm
  - 30 dBm
12. Which of the following is one of the functions performed by a diode?
- filter
  - amplifier
  - rectifier
  - inverter
13. Refer to Figure 1A. What is the total resistance of this circuit?
- 10  $\Omega$
  - 25  $\Omega$
  - 40  $\Omega$
  - 55  $\Omega$

14. Refer to Figure 2. Which component is used to protect against high-voltage transients?
- B
  - E
  - G
  - H
15. Refer to Figure 1A. What is the voltage drop across R1?
- 4.8 V
  - 9.6 V
  - 19.2 V
  - 28.8 V
16. A transmission line is rated at 25 pF/ft. How much capacitance will one mile (5280 ft) of this transmission line have?
- 13,200 pF
  - 13.2 nF
  - 132 nF
  - 1.32  $\mu$ F
17. Refer to Figure 1C. In this circuit, what is the function of the inductor?
- high pass filter
  - low pass filter
  - band pass filter
  - band stop filter
18. There is no voltage measured across R4. Which if the following component failures is the most probable cause?
- R4 open
  - R5 shorted
  - R2 open
  - R3 shorted
19. A power amplifier has a gain of 20 dB and an input level of 2 volts. Assuming that the input and output impedances are the same, what is the voltage level at the amplifier output?
- 10 V
  - 20 V
  - 30 V
  - 40 V
20. A precision current shunt is measuring 100 millivolts across it. This indicates a current of 25 A. What is the actual resistance of this shunt?
- 0.004  $\Omega$
  - 0.04  $\Omega$
  - 0.25  $\Omega$
  - 2.5  $\Omega$
21. What is the relationship between current (I) and voltage (E) in a circuit consisting of a capacitor in series with a resistor?
- I and E are in phase across the capacitor.
  - I leads E across the resistor.
  - E leads I across the capacitor.
  - I and E are in phase across the resistor.

22. The leads of a multimeter are across a diode in the following manner:  
Red lead connects to the end of diode with marking band, and the black lead connects on other end. What does a reading of -0.6 volts indicate?
- forward bias, leads connected with proper polarity
  - reverse bias, leads connected with proper polarity
  - forward bias, leads connected with reverse polarity
  - reverse bias, leads connected with reverse polarity
23. All other factors remaining the same, what is the effect of increasing wire gauge, for example, from AWG 22 to AWG 26?
- Impedance will decrease.
  - Resistance will increase.
  - Inductance will decrease.
  - Capacitance will increase.
24. What is the "power factor"?
- ratio of true power to apparent power
  - peak power times .707
  - sin of the phase difference between E and I
  - cos of the phase angle between true power and apparent power
25. A power system is providing 200 VAC at 25 A. The phase angle between current and voltage is  $25^\circ$ . What is the true power used by the system?
- 2,113 W
  - 4,531 W
  - 5,517 W
  - 11,831 W

**REFERENCE SHEET**

**Formulas**

$$E = IR \qquad PF = \cos \Theta = \frac{P_{true}}{P_{app}} \qquad V_{rms} = V_{peak} \times .707$$

$$P = IE \qquad dB = 10 \times \log_{10} \left( \frac{W_{out}}{W_{in}} \right) \qquad dB = 20 \times \log_{10} \left( \frac{V_{out}}{V_{in}} \right)$$

**Figure 1.**

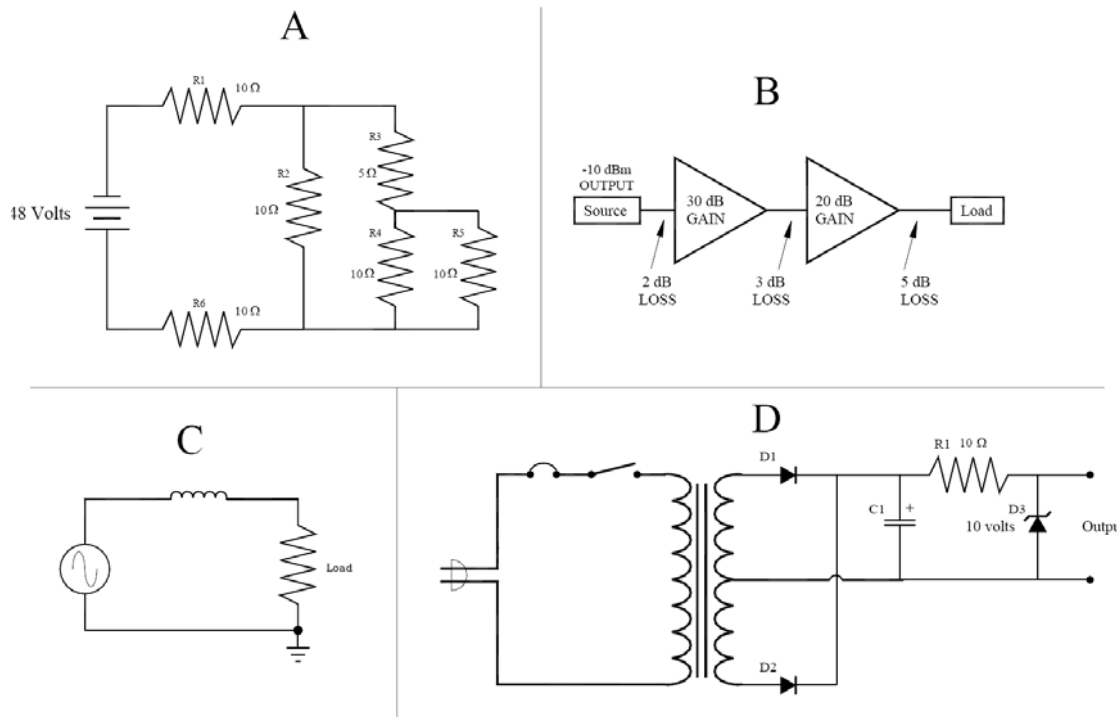

**Figure 2.**

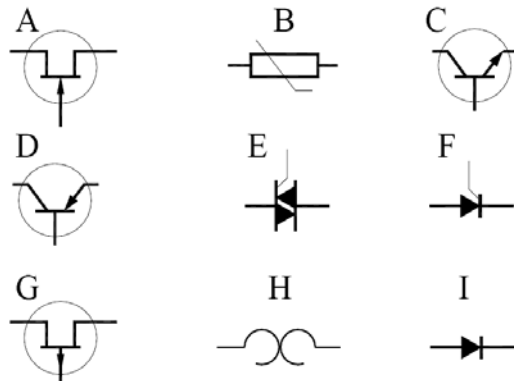



## SCORING THE PRACTICE TEST

1. Use the key answers given below to score your Practice Test.

1. B	11. D	21. D
2. C	12. C	22. C
3. B	13. B	23. B
4. D	14. A	24. A
5. C	15. C	25. B
6. A	16. C	
7. C	17. B	
8. D	18. B	
9. C	19. B	
10. C	20. A	

2. Count the number of questions you answered correctly. This is your total score.

3. Make a list of the questions you missed or got right but were unsure of. Review the explanation of those questions on the following pages.

## EXPLANATION OF PRACTICE TEST QUESTIONS

1. **(B)** When values are in decibels, simply add the gains and subtract the losses from the original level to determine the expected power level.

$$-10 \text{ dBm} - 2 \text{ dB} + 30 \text{ dB} - 3 \text{ dB} + 20 \text{ dB} - 5 \text{ dB} = \mathbf{30 \text{ dBm}}$$

2. **(C)** A communications system consists of a source, a medium and a sink (also referred to as a load or receiver). Efficient transfer of signal power depends on matching the impedance of each of these system components. When an impedance mismatch is present, the source “sees” a reactive load (refer to Question 21 discussion). When this occurs, I and E are out of phase. Under these conditions, not all the signal energy is transferred to the receiver. The energy not transferred must go somewhere, so it returns to the source. This is referred to as **reflected energy**, commonly called “echo.” In order to reduce the level of reflected energy, it is important to match the impedance of the medium and the sink to the source.

3. **(B)** The letter X, combined with a subscript, is the symbol for **reactance**.  $X_C$  represents the reactance of capacitive components.  $X_L$  represents the reactance of inductive components, commonly referred to as “coils.”

4. **(D)** A coulomb is a quantity of electrons,  $6.25 \times 10^{18}$  electrons to be exact. Current is the flow of electrons, and an ampere is a specific unit of current flow: one coulomb passing a point in one second is **1 ampere**.

5. **(C)** In solid state component symbols, the arrow always points toward the N-type material. A PNP transistor will have the **arrow pointing at the base** as in Figure 2D.

6. **(A)** The frequency of a signal is the number of times it goes through a complete cycle of  $360^\circ$  in one second. A 1000-Hz signal completes 1000 cycles in one second. The period of a signal is the length of time it takes to complete one cycle, and a 1000-Hz signal has a period of 0.001 seconds (1/1000 of a second). As the frequency goes higher, the period becomes shorter: 10,000 Hz has a period of 0.0001 seconds (1/10,000 of a second). Therefore, frequency and **period** are inversely related. All other answer choices are independent of frequency.

7. **(C)** The amount of power wasted in heat is a function of efficiency. Any power that is not useful, such as signal power, is wasted in heat. In order to determine the amount of wasted power, the total input power must first be determined by using the power formula (see Reference Sheet):

$$P = IE$$

Once the total input power is found, subtract the useful power from it. What is left is the power wasted in heat.

$$P = IE = 0.1 * 48 = 4.8 \text{ W}$$

$$4.8 \text{ W} - 1.5 \text{ W} = \mathbf{3.3 \text{ W}}$$
 of wasted power

8. **(D)** A zener diode is a voltage regulating device. Its voltage rating is an indication of the reverse bias breakdown point (avalanche point). This is the level of voltage that will be measured across the zener diode when the voltage provided to it is higher than the zener rating.

The zener diode in the Figure 1D is rated at 10 V; therefore, if 20 V is measured across the diode, it must not be functioning. In this instance, D3 (zener) must be **open**.

9. **(C)** Refer to the discussion of Question 7.

10. **(C)** There is a simple relationship between peak voltage and rms voltage of a sine wave. The rms voltage is  $0.707 * \text{peak voltage}$  (see Reference Sheet). When the rms voltage (also called *effective voltage*) is known, solve for peak voltage by dividing the rms voltage by 0.707.

$$V_{\text{peak}} = \text{rms}/0.707 = 220/0.707 = \mathbf{311 \text{ VAC}}$$

11. **(D)** The decibel (db) is the unit used to measure levels in telecommunications. It is based on the base 10 logarithm of a ratio (Reference Sheet). The ratio can be the ratio of input to output for indicating relative gains and losses in a system. The ratio can also be the ratio of a level relative to an absolute value. This question considers both types of decibels.

To determine the power level at the input to the receiver, convert the 1 mW (milliwatt) to dBm (decibels relative to a 1 mW reference) as follows:

$$10 * \log(\text{value}/\text{reference value}) = 10 * \log(1\text{mW}/1\text{mW}) = 0 \text{ dBm}$$

Since the output level equals the reference level, the value of 1 mW is 0 dBm. The total loss of the link is:

$$5 \text{ dB}/1000\text{ft} * 6 = 30 \text{ dB loss.}$$

The level into the receiver = 0 dBm - 30 dB = **-30 dBm**.

12. **(C)** Different type of diodes perform different functions, one of which is **rectifier** which converts AC to pulsating DC.

13. **(B)** The circuit in Figure 1A consists of a combination of series and parallel paths. In order to find the total resistance, the circuit must be simplified. Simplification is the combination of series or parallel branches into a single value of resistance. The process is performed until there is only one value left.

To combine series values, just add them together. To combine parallel branches in which the values in each branch are the same (as in Figure 1A), divide the value of one branch by the number of branches. Simplifying the Figure 1A:

- Combine parallel branches R4 and R5:  $10 \Omega/2 = 5 \Omega$ .
- Combine Step a in series with R3:  $5 \Omega + 5 \Omega = 10 \Omega$ .
- Combine Step b in parallel with R2:  $10 \Omega/ 2 = 5 \Omega$ .
- Combine Step c in series with R1 and R6:  $5 \Omega + 10 \Omega + 10 \Omega = \mathbf{25 \Omega}$ .

14. **(A)** A solid state device used to protect equipment against high voltage transients (spikes) must have a very fast turn-on time. The component most commonly used for this purpose is the metal oxide varistor (MOV). **Figure 2B** is the electronic symbol for this component.
15. **(C)** Since this circuit was simplified in Question 13, the total resistance (25  $\Omega$ ) is already known. Use Ohm's law (Reference Sheet) to solve for I which gives the total current flowing through the circuit. Since the resistors are in series, the same amount of current flows through each resistor.

The next step is to solve for E across R1, using Ohm's law.

$$I = E/R = 48/25 = 1.92 \text{ A}$$

$$E = IR = 1.92 * 10 = \mathbf{19.2 \text{ V}}$$

16. **(C)** Transmission lines are typically rated for the amount of capacitance per foot. Given that there are 5,280 feet in one mile, a 1-mile transmission line rated at 25 pF/ft has a total capacitance of:

$$5,280 * 25 \text{ pF} = 132,000 \text{ pF.}$$

Moving the decimal point three places to the left will provide the answer in nF (nanoFarads), **132 nF**.

17. **(B)** Inductive reactance and frequency have a direct relationship. As frequency increases, inductive reactance increases. Therefore, in the circuit shown in Figure 1C, the higher frequencies coming from the source will be attenuated more by the inductor than the lower frequencies will. Attenuating higher frequencies while passing lower frequencies is the function of a **low pass filter**.
18. **(B)** There are two possible reasons for the no-voltage reading across R4.
- An open circuit between the source and R4
  - A short across R4 or a parallel branch—**R5**
19. **(B)** Refer to the decibel discussion in Question 11. Decibels can be used for determining voltage gains and losses as well as power gains and losses. The formula for this function (see Reference Sheet) is:

$$\text{dB} = 20 * \log(\text{voltage ratio})$$

In order to determine the output voltage, solve for the voltage ratio and then multiply the input level by the ratio to find the output level. Solving for the gain ratio:

$$10^{20/20} = 10^1 = 10$$

Output voltage level is:

$$\text{input level} * \text{gain ratio} = 2 \text{ V} * 10 = \mathbf{20 \text{ V}}$$

20. **(A)** Current shunts are used to multiply the measuring capability of current meters. The voltage drop across the shunt is actually the indicator of the amount of current flowing through the device. Use Ohm's Law (Reference Sheet) to determine the resistance of the shunt. Solving for resistance:

$$R = E/I = .1 \text{ volts}/25 \text{ amps} = \mathbf{0.004 \Omega.}$$

21. **(D)** See Question 9 for a discussion of the phase relationship between I and E in a reactive circuit (capacitive or inductive). Current and voltage will be out of phase in a reactive circuit. If the circuit is inductive, the voltage will lead the current. If the circuit is capacitive, the current will lead the voltage. Across purely resistive elements in a reactive circuit, the current and voltage will still be in phase.

Since the circuit in the question is capacitive, the current will lead the voltage across the capacitive element. However, there will be **no phase difference between I and E across the resistor**.

22. (C) The physical band located on a diode indicates the cathode (negative) end of the diode. A diode typically will drop approximately 0.6 volts across it when negative voltage is applied to the cathode and positive voltage is applied to the anode. This is referred to as *forward bias*.

When measuring voltage across a diode with a multi-meter, the red lead is connected to the anode and the black lead is connected to the cathode. In this configuration, 0.6 volts will be seen when the diode is forward biased. If the **test leads are reversed and the diode is forward biased**, a reading of -0.6 volts will be seen.

23. (B) The resistance of a conductor is inversely proportional to the amount of cross-sectional area. The greater the cross-sectional area, the more freely electrons are allowed to move, lowering resistance to flow.

The American Wire Gauge (AWG) numbers are based on the number of times a large diameter wire of specific starting size must be pulled through a successive number of reducing dies in order to reach the end wire size. Therefore, high AWG numbers refer to large wires which must be drawn through many reducing dies in order to reach the final diameter, and low AWG numbers refer to small wires which require fewer reductions.

An AWG 22 wire has a greater diameter than an AWG 26 wire. Greater diameter means greater cross-sectional area which means lower resistance, so **resistance will increase** as wire gauge increases.

24. (A) Refer to Question 25. Using the true power formula (Reference Sheet) to solve for the PF demonstrates the relationship between the true power and the apparent power:

$$PF = P_{\text{True}}/P_{\text{App}} = \text{ratio of true power to apparent power}$$

25. (B) When power or a signal is provided in the form of alternating current, the voltage and current can be out of phase with each other. This occurs when the load is reactive (capacitive or inductive). When this is the case, the power transferred to the load is no longer a function of  $P = IE$ . The power formula in a reactive circuit is only useful for calculating the apparent power ( $P_{\text{app}}$ ).

In order to determine the true power ( $P_{\text{True}}$ ) transferred to the load, the phase angle between I and E must be considered. The cos of the phase angle between I and E is referred to as the power factor (PF). To determine the transferred power in a reactive circuit:

Determine the apparent power:  $P = IE = 25 * 200 = 5000 \text{ VA (volt-amps)}^1$

Determine the PF:  $PF = \cos(25^\circ) = .9063$

Multiply the PF times the  $P_{\text{app}}$ :  $P_{\text{True}} = P_{\text{App}} * PF = 5000 * .9063 = \mathbf{4531 \text{ Watts}}$

<sup>1</sup> If I and E are in phase the PF = 1 and the formula  $P = IE$  would provide the true power.

## **HOW DID I DO?**

The Practice Test questions are very similar to—but not the same as—the questions you'll see on the real test. Your Practice Test score will give you a good idea of how well you could expect to do on the real test but, of course, only your score on the real test counts.

Find your score level below to get a good idea of how well prepared for the test you are right now.

### **If your Practice Test score was...**

- 20 – 25** Congratulations! You are ready to take the real test and should have an excellent chance of qualifying. **Get ready for the test** with the help of the hints in the next section.
- 15 – 19** You did pretty well but are probably a little rusty in some areas. If you took the real test now, you would have a fair chance of qualifying. You can improve the odds if you **review your weak areas** first. See the next section.
- 10 – 14** Although you know some of the material, your score indicates that there are some subjects that you've never studied or haven't worked with in quite a while. Use the next section to **plan a study strategy**.
- 0 – 9** You do not know the material well enough to prepare on your own. If you're still interested in taking the test, **take a course**. Find out what to look for in the next section.

## **WHAT CAN I DO TO PREPARE FOR THE TEST?**

When you are scheduled for the Basic Electronics Test, you will be given a specific time to report to the testing location. Try to arrive at the location at least 15 minutes before your scheduled test time to give yourself time to relax before the test begins. Review this Test Information Pamphlet and be prepared for the test by bringing your glasses, etc. Ask questions before the test begins, and be sure you understand the format of the Basic Electronics Test.

FOR EMPLOYEES ONLY: You may contact the AT&T Self Development Resource Center located on HROneStop at <http://hronestop.att.com> >> Your Career >> Self Development >> Test Preparation to inquire about study guides, textbooks, and/or general course information that may help you prepare for the test.

### **TIPS FOR CHOOSING A COURSE**

If you got a low score on the practice test or if you don't have a lot of the knowledge and skill described on pages 2 - 3, you should take a course before taking the real test.

#### **Course Format**

- Find a course in which you can ask questions or get help as needed. This is particularly important if you are brand new to electricity and electronics.
- A classroom-based course offered by a technical school or two-year college and taught by an experienced instructor is one good choice.

#### **Course Content**

- Don't go by names alone! Compare the knowledge and skills covered by the test (listed on pages 2 - 3) to those covered in any course you're considering.
- To get the best foundation, start with a course on electricity then move on to electronics. If that isn't possible, find an introductory level combination course. Some courses sponsored by individual companies cover both subjects together.
- If you're unsure whether a certain course covers what you need, ask someone at the institution offering the course, preferably the instructor.

## **Math Skills**

- Don't forget the math and calculator skills because you'll need them right away.
- If you don't know how to solve simple equations or work confidently with negative numbers and decimals, get these skills first. You can either:
  - Find a math review book and brush up on your own, perhaps with the help of a friend; *or*
  - take an applied math course; *or*
  - choose an electricity/electronics course that includes a math module at the beginning.
- If you know the math basics but are unsure about powers and logs, you can probably start right in with a basic electricity course.

## **TIPS FOR STUDYING ON YOUR OWN**

If you have some experience in this field or have already taken a course, perhaps some time ago, you should plan a study strategy.

### **1. Identify Your Weak Areas**

- Re-read the explanations for any Practice Test questions you missed.
- Read through all the knowledge and skill areas listed on pages 2 - 3.
- Mark the areas in which you have no training or work experience and the ones related to the practice questions you missed or didn't understand.

### **2. Find a Textbook or Website**

- Look for books and websites that cover the subjects you need.
- Books and websites that have practice problems and exercises to let you check your understanding are the best.
- Examples:
  - Fowler, Richard J. (1994). Basic Electricity: Principles and Applications. New York: Glencoe/McGraw-Hill.
  - Schuler, Charles A. (1994). Basic Electronics: Principles and Applications. New York: Glencoe/McGraw-Hill.

### **3. Study**

- Identify the sections you need to study.
- Concentrate on one section at a time.
- Work the problems and do the exercises.
- If you have trouble with a topic, read the material again. If you still have trouble, find another source of information. A new explanation often helps.

### **4. Check Your Progress**

- Take the Practice Test again or answer the review questions contained in your book.

## **TIPS FOR REVIEWING YOUR WEAK AREAS**

Since you did pretty well on the practice test, a little review may be all you need.

### **1. Identify Areas for Review**

- Re-read the explanations for any Practice Test questions you missed.
- Read through all the knowledge and skill areas listed on pages 2 - 3.
- Mark ones you feel rusty on and the ones related to the practice questions you missed.

### **2. Find a Textbook or Manual**

(See "Tips for Studying.")

### **3. Review Sections Related to Your Weak Areas**

## **TIPS FOR GETTING READY TO TAKE A TEST**

Whether you did well on the Practice Test or have just completed a course of study, it can be helpful to do a quick review just before you take the real test to build your confidence and make sure you do your best.

- 1. Find a Textbook or Manual**  
(See "Tips for Studying.")
- 2. Read the chapter summaries or overviews**
- 3. Review relevant formulas, symbols, and abbreviations so that you can recognize them easily.**

## **RETEST INTERVALS**

If it should happen that you do not qualify on the Basic Electronics Test, your first retest opportunity is at six months. Subsequent retests are at one-year intervals. Test standards are periodically updated to reflect current abilities and skills required for our jobs. Therefore, it may be necessary to meet new test standards should they be introduced prior to your placement on the job.

## **SUMMARY**

Successful completion of the Basic Electronics Test qualifies you for possible placement into jobs requiring the test. Additional testing may be required for certain positions. See job briefs in your area for additional testing requirements for titles you are interested in.

**AT&T and its affiliates support and comply with the provisions of the Americans with Disabilities Act (ADA) and other Federal and State laws that specifically assist individuals with disabilities. If you have a limiting disability and need special testing arrangements, please ask your local Employment Office or Placement Bureau personnel for information about the testing accommodation process.**