

HARYANA STATE ROADS & BRIDGES DEVELOPMENT CORPORATION LTD.

BIDDING DOCUMENT FOR

**FRANCHISING TOLL COLLECTION
UKLANA TOHANA MUNAK ROAD (TP-22)
FOR A PERIOD OF ONE YEAR**

**Dy. General Manager,
for Managing Director,
Haryana State Roads and Bridges
Development Corporation Ltd.
Panchkula.**

**FRANCHISING TOLL COLLECTION AT TOLL POINT ON
UKLANA TOHANA MUNAK ROAD (TP-22)
FOR A PERIOD OF ONE YEAR FOR A PERIOD OF ONE YEAR**

I N D E X

| Sr. No | Particulars | Page No |
|-----------|--|---------|
| | <u>SECTION-1</u> | |
| i) | Press Notice | |
| ii) | Detailed Notice Inviting Tender | |
| iii) | Conditions of e-tendering | |
| | <u>SECTION-2</u> | |
| i) | Instructions to Bidders | |
| | <u>SECTION-3</u> | |
| 3. | Definitions (Section-3) | |
| | <u>SECTION-4</u> | |
| 4. | Form of Bid (Section-4) | |
| | <u>SECTION-5</u> | |
| 5. | Letter of Acceptance (Section-5) | |
| | <u>SECTION-6</u> | |
| 6. | Form of Agreement with conditions (Section-6) | |
| | <u>SECTION-7</u> | |
| 7. | Schedule of Toll (Section-7) | |
| | <u>SECTION-8</u> | |
| 8 | Functions & duties to be performed by the entrepreneur/agent Schedule 1 (Section-8) | |
| | <u>SECTION-9</u> | |
| 9. | Details of the registers to be maintained by the agent at fee collection gates Schedule-2 & 3 (Section-9) | |
| | <u>SECTION-10</u> | |

| | | |
|-----|---|--|
| 10. | Section-10 Form No. 1 Specimen form of receipt to be issued for collection of toll Form No. 2 Report of inspection of an Authorised Officer Form No. 3 Register showing the checking of fee collection gates | |
| | <u>SECTION-11</u> | |
| 11. | Form of Bid Security (Bank Guarantee) - (Section-11) | |
| | <u>SECTION-12</u> | |
| 12. | Form of Security Deposit (Bank Guarantee) - (Section-12) | |
| 13. | <u>ANNEXURE-I</u> Guidelines for Bank Guarantee | |
| 14. | <u>ANNEXURE-II</u> Detail of boards to be installed along with layout plan | |

Section 1 (i)**PRESS NOTICE****Haryana State Roads and Bridges Development Corporation Ltd.**

(A State Government Undertaking)

Bay No.13-14, Sec.2 Panchkula (Haryana) Tel. No. 0172-2585264, Fax 0172-2583264

No. /HSRDC**Dated:****Notice Inviting Tenders**

- Online bids are hereby invited in the website: <http://haryanapmgsy.etenders.in> on behalf of Executive Director, HSRDC for the Toll fee for a period mentioned against each for toll points mentioned as below:-
- Pre bid meeting will be held on 24.05.2012 at 11.30AM.

| Sr No. | Name of Toll Facility | Period | Bid Security (Rs. in lacs) | Date and time for bid preparation and Hash Submission. |
|--------|--|--------|----------------------------|--|
| 1 | BAHADURGARH JHAJJAR DADRI LOHARU PILANI ROAD (TP-6) | 1 year | 5.00 | 09.05.2012 at 17:01 hrs to 31.05.2012 at 17:00 hrs |
| 2 | SHAMLI PANIPAT ROAD NEAR UP BORDER (TP-13) | 1 year | 43.00 | |
| 3 | SOHANA NUH FEROPUR ZHIRKA ALWAR ROAD(TP-16) | 1 year | 20.00 | |
| 4 | NARNAUL NIZAMPUR ROAD NEAR RAJASTHAN BORDER (TP-18) | 1 year | 16.00 | |
| 5 | UKLANA TOHANA MUNAK ROAD (TP-22) | 1 year | 5.50 | |
| 6 | ROHTAK KHARKHAUDA DELHI BORDER ROAD (TP-27) | 1 year | 7.50 | |
| 7 | BHATTU LUDESAR JAMAL RAOD UPTO RAJASTHAN BORDER(TP-28) | 1 year | 5.00 | |
| 8 | RAI NAHRA BAHADURGARH ROAD (TP-40) | 1 year | 12.00 | |

- Cost of bid document (to be paid only on-line) is Rs. 10,000/- (non-refundable).
- For further details and e-tendering schedule visit website <http://haryanapwd-bandr.org> / <http://haryanapmgsy.etenders.in> / <http://hsrdc.in>

Dy. General Manager (Toll),
Haryana State Roads & Bridges
Development Corporation Ltd.,
Panchkula.
(Phone 0172-2585264)

Section 1 (ii)

DETAIL NOTICE INVITING TENDER

1. Online bids are hereby invited in the website: <http://haryanapmgsy.etenders.in> on behalf of Executive Director, HSRDC for the Toll fee for a period mentioned against each for toll points mentioned as below:-
2. Pre bid meeting will be held on 24.05.2012 at 11.30 AM.

| Sr No. | Name of Toll Facility | Period | Bid Security (Rs. in lacs) | Date and time for bid preparation and Hash Submission. |
|--------|----------------------------------|--------|----------------------------|--|
| 1 | UKLANA TOHANA MUNAK ROAD (TP-22) | 1 year | 5.50 | 09.05.2012 at 17:01 hrs to 31.05.2012 at 17:00 hrs |

3. Bidding Documents can be downloaded online from the Portal <http://haryanapmgsy.etenders.in> by the Societies / Contractors registered on the Portal.
4. As the Bids that are to be submitted online are required to be encrypted and digitally signed, the Bidders are advised to obtain the same at the earliest. For obtaining Digital Certificate, the Bidders may contact the representative of Next Tenders, the Service Providers of Electronic Tendering System.

5. Key Dates

| Sr. No. | HSRDC Stage | Contractor Stage | Start Date and Time | Expiry Date and Time |
|---------|------------------------------|--|--------------------------|--------------------------|
| 1 | Release of Tender | - | 08.05.2012 10.00 hrs. | 09.05.2012 17.00 hrs. |
| 2 | - | Download Tender Document | 09.05.2012 17.01 hrs. | 31.05.2012 17.00 hrs. |
| 3 | - | Online Bid Preparation & Hash Submission | 09.05.2012 17.01 hrs. | 31.05.2012 17.00 hrs. |
| 4 | Technical and Financial Lock | - | 31.05.2012 17.01 hrs. | 31.05.2012 20.00 hrs. |
| 5 | - | Re-encryption of Online Bids | 31.05.2012 20.01 hrs. | 05.06.2012 13.00 hrs. |
| 6 | | Manual Submission of EMD | 01.06.2012 10.00 hrs. | 05.06.2012 13.00 hrs. |
| 7 | Open EMD & Technical/PQ bid | - | 05.06.2012 13.01hrs. | 05.06.2012 17.00 hrs. |
| 8 | Technical Evaluation | - | 05.06.2012 13.01hrs. | 05.06.2012 17.00 hrs. |
| 9 | Open Financial / Price-Bid | - | 06.06.2012 12.00 hrs. | 06.06.2012 17.00 hrs. |

6. The Bidders can download the bidding documents from the Portal <http://haryanapmgsy.etenders.in> Tender Documents Fees has to be paid online during the Bid Preparation and Hash Submission stage and Earnest Money Deposit in one of the form mentioned in clause 8.1 of Section-2 and as per guidelines approved by Board of Directors (**Annexure-I**) has to be submitted in a separate sealed EMD envelope in favour of the Managing Director, Haryana State Roads and Bridges Development Corporation, Panchkula. Desirous Contractors shall have to pay the Tender Document Fees mentioned against the work at the time of Bid Preparation and Hash Submission stage. The EMD envelop has to reach in the office of Executive Director, Haryana State Roads and Bridges Development Corporation, Bay No. 13-14, Sector 2, Panchkula on or before **05.06.2012 at 13.00 Hrs.** However, as the details of the EMD are required to be filled at the time of Bid Preparation and Hash Submission stage, the Bidders are required to keep the EMD ready appropriately.
7. The tender shall be submitted by the tenderer in the following three separate envelops online:
1. Earnest Money - Envelope 'ED'
 2. Technical Bid - Envelope 'TI'
 3. Tender in Form – A (Price Bid) - Envelope 'CI'

Note: **Online Bidders are required to submit the physical EMD in a physical EMD Envelop – 'ED' after Hash Submission stage till the period of re-encryption of online bids given in the key dates. Reference of the EMD is to be mentioned mandatory Online. All other documents related to Technical Bid shall be submitted mandatory online in Technical Envelop – 'TI' and shall not be accepted in any physical form. Price Bids are to be submitted mandatory online and shall not be accepted in any physical form.**

EMD envelop, as applicable, shall be kept in a big outer envelop, which shall also be sealed, In the first instance, the Envelop – 'ED' of all the Bidders containing the Earnest Money shall be opened online and physically. If the Earnest Money is found proper, the Envelop 'TI' containing online Technical Bid shall be opened in the presence of such contractors who choose to be present. The Financial Offer in Envelop in 'CI' shall be opened only if the tenderers meet the qualification criteria as per the Bid document.

The Contractual Agencies will submit the necessary documents as under.

Envelop 'ED' – Earnest Money Deposit Envelope

Physical EMD Envelop – Earnest Money in shape of Bank guarantee (Annexure-1).

Online EMD Envelope—Reference details of the Earnest Money Deposit instrument and scanned copy of the Earnest Money Deposit.

Envelope ‘TI’ – Technical Bid Envelope

Online Technical Envelope – To be submitted mandatory online all the information and scanned copies of the Documents / Certificates as required to be submitted as per the Tender.

In case process of Hash Submission for financial bid and technical bid is completed but the re-encryption of online bid is not carried out and/or physical earnest money deposit is not submitted by any bidder, then bidder would be debarred from further tendering in HSRDC/Haryana PWD (B&R) for a period of minimum 2 years.

Envelope ‘CI’ – Price Bid Envelope

To be submitted mandatory online- Information related to Price Bid of the Tender. The Envelopes “ED” shall be placed in another envelopes of bigger size clearly marking the name of agency & name of work. Envelope “TI” will be only opened if the Contractual Agency fulfills condition in Envelope “ED”.

The contractual Agencies can submit their tender documents (Online and physical) as per the dated mentioned in the key Dates above:-

CONDITONS:-

- 1) DNIT & Prequalification can be seen on any working day during office hours in office of the undersigned.
- 2) Conditional tenders will not be entertained & are liable to be rejected.
- 3) In case the day of opening of tenders happens to be holiday, the tenders will be opened on the next working day. The time and place of receipt of tenders and other conditions will remain unchanged.
- 4) The undersigned reserve the right to reject any tender or all the tenders without assigning any reason.
- 5) The societies shall produce an attested copy of the resolution of the Co-Operative department for the issuance of tenders.
- 6) The tender without earnest money will not be opened.
- 7) The jurisdiction of court will be at Panchkula.
- 8) The tender of the bidder who does not satisfy the qualification criteria in the bid documents are liable to be rejected summarily without assigning any reason and no claim whatsoever on this account will be considered.
- 9) The bid for the work shall remain open for acceptance during the bid validity period to be reckoned from the last date of **manual physical submission of EMD**. If any bidder/ tenderer withdraws his bid/ tender before the said period or makes any modifications in the terms and

conditions of the bid, the said earnest money shall stand forfeited. Bids would require to be valid for 180 days from the date of bid closing i.e. from last date of manual submission of EMD. In case the last day to accept the tender happens to be holiday, validity to accept tender will be the next working day.

Deputy General Manager (Toll),
For Executive Director,
Haryana State Roads and Bridges
Development Corpn. Ltd., Panchkula
(Phone 0172-2585264)

SECTION-1 (iii)

CONDITIONS OF E-TENDERING

Instruction to Contractor on Electronic Tendering

1. **These conditions will over-rule the conditions stated in the tender documents, wherever relevant and applicable.**
2. All the Contractors intending to participate in the tenders processed online, are required to get registered on the Electronic Tendering System on the Portal <http://haryanapmgsy.etenders.in>. For more details, please see the information in Registration info link on the home page.
1. **Obtaining a Digital Certificate:**
 - 3.1 The Bids submitted online should be encrypted and signed electronically with a Digital Certificate to establish the identity of the bidder bidding online. These Digital Certificates are issued by an approved certifying authority, by the controller of Certifying Authorities, Government of India.
 - 3.2 A Digital Certificate is issued upon receipt of mandatory identity proofs and verification letters attested by the bankers with whom the contractor maintains the accounts with. Only upon the receipt of the required documents, a digital certificate can be issued.
 - 3.3 The contractors may obtain Class II B digital certificated from any Certifying Authority or Sub-certifying Authority authorized by the Controller of Certifying Authorities or may obtain information and application format and documents required to issue of digital certificate from:
 1. NexTenders (India) Pvt. Ltd.
YUCHIT, Juhu Tara Road,
Mumbai – 400049
Email: Chandigarh@nextenders.com
 2. NexTenders (India) Pvt. Ltd.
O/o HSRDC, Bays No. 13-14, Sec-2,
Panchkula-134151
Contact Person: Manmeet-+919815034028(Panchkula)
Anujeet- +918146440101(Panchkula)
Sat Dev Sharma- +919872252144(Panchkula)
Sanjay Kumar - +8743042801 (Gurgaon)

Bid for a particular tender may be submitted only using the digital certificate, which is used to encrypt the data and sign the hash during the stage of bid preparation and hash submission. In case, during the process

of a particular tender, the user loses his digital certificate (i.e. due to virus attack, hardware problem, operating system problem); he may not be able to submit the bid online. Hence, the users are advised to back up the certificate and keep the copies at a safe place under proper security to be used in case of emergencies.

3.4 In case of online tendering, if the digital certificate issued to the authorized user of a firm is used for signing and submitting a bid it will be considered equivalent to a no-objection certificate/power of attorney to that User. The firm has to authorize a specific individual via an authorization certificate signed by all partners to use the digital certificate as per Indian Information Technology Act 2000. Unless the certificates are revoked, it will be assumed to represent adequate authority of the user to bid on behalf of the firm for Haryana State Roads and Bridges Development Corporation Limited tenders as per Information Technology Act 2000. The digital signature of this authorized user will be binding on the firm. It shall be the responsibility of management / partners of the registered firms to inform the certifying authority of Sub / Certifying Authority, if the authorized user changes, and apply for a fresh digital certificate and issue a 'authorization certificates' for the new user. The procedure for application of a digital certificate will remain the same for the new user.

3.5 The same procedure holds true for the authorized users in a private/Public limited company. In this case, the authorization certificate will have to be signed by the directors of the company.

4. Opening of an Electronic Payment Account:

4.1 For purchasing the tender documents online, contractors are required to pay the tender documents fees online using the electronic payments gateway service as mentioned in the D.N.I.T.

4.2 For the list of payments using which the online payments can be made, please refer to the Home page of the Portal <http://haryanapmgsy.etenders.in>.

5. Set up of machine

5.1 In order to operate on the electronic tender management system, a user's machine is required to be set up. A help file on setting up of the system can be obtained from next Tenders (India) Pvt. Ltd. or downloaded from the home page of the website - <http://haryanapmgsy.etenders.in>.

6. Online Viewing of Detailed Notice Inviting Tenders:

- 6.1** The contractors can view the detailed N.I.T and the time schedule (Key Dates) for all the packages floated using the electronic tendering system on the Haryana PWD B&R website <http://haryanapmgsy.etenders.in>

7. Purchase of Tender Documents:

- a) Download of Tender Documents: The tender documents can only be downloaded from the Electronic Tendering System on the Portal <http://haryanapmgsy.etenders.in>

8. Submission of Bid Seal (Hash) of online Bids:

- 8.1** Submission of bids will be preceded by submission of the digitally signed bid seal (Hash) as stated in the tender time schedule (Key Dates) of the Tender.

9. Generation of Super Hash:

- 9.1** After the time of submission of Bid Seal (Hash) by the Contractors has lapsed, the bid round will be closed and a digitally signed tender Super Hash will be generated by authorized Haryana PWD B&R official. This is equivalent to sealing the tender box.

10. Submission of actual online bids:

- 10.1** Contactors have to submit their encrypted bids online and upload the relevant documents for which they generated the hash at the stage of hash generation and submission after the generation of Super Hash within the date and time as stated in the Notice Inviting Tenders (Key Dates). The electronic bids of only the contactors who have submitted their bid seals (Hashes) within the stipulated time, as per the tender time schedule (Key Dates), will be accepted by the System. A contractor who does not submit his bid seal (Hash) within the stipulated time will not be allowed to submit his bid.

11. Submission of Tender Document Fees:

- 11.1** The Payment can be made by eligible / contractors online directly via Credit Cars / Internet Banking Accounts / Cash Cards. The contractors have to pay for the tender documents online by making online payment of tender document fees using the service of the secure electronic payment gateway. The secure electronic payments gateway is an online interface between contractors and credit card / online payment authorization networks.

12. Submission of Earnest Money Deposit:

- 12.1** The EMD Payment can be made by eligible contractors through one of the form mentioned in clause 8.1 of Section-2 and as per guidelines approved by Board of Directors (**Annexure-I**).
- 12.2** Contractors have to submit the EMD physically in a sealed physical envelope and the same should reach the office of concerned Executive Director as mentioned in the Tender Notice.

13. Key Dates:

- 13.1** The contractors are strictly advised to follow dates and times as indicated in the Notice Inviting Tenders. The date and time will be binding on all contractors. All online activities are time tracked and the system enforces time locks that ensure that no activity or transaction can take place outside the start and end dates and time of the stage as defined in the Notice Inviting Tenders.

Other Information:

1. The intending Contractors shall fill in the lumpsum rate in the online templates in of the online tender. The Price Bid has to be submitted mandatory online.
2. Online bidders are required to submit the physical EMD in a physical EMD Envelop and delivered to this office before the date and time mentioned in the Tender Notice. *The pre-requisites for eligible bidders mentioned in the **Section 2 (Instructions of bidders)** alongwith the below mentioned document list shall be uploaded in the online templates available under Envelope TI and will not be accepted in physical form:*
 - i. A list of all documents accompanying the sealed envelopes containing the tender documents.
 - ii. Duly accepted power of Attorney in the name of tenderer or authorized representative to act on behalf of the agency.
 - iii. Documents in respect of payment of earnest money.
3. a) Tender must strictly abide by the stipulations set forth in detailed notice inviting tenders while tendering for the work, the tenderer shall adopt only the three envelope system.
 - b) Deleted.
4. The second envelop – Price Bid envelope has to be submitted mandatory online and shall not be accepted physically under any circumstances. In case any tenders does not comply with procedure given above, will be presumed that he is not interested in the work and the work shall not be let out to him, further he may be de-listed without further notice to him

for failing to abide by the strictly approved terms of detailed notice inviting tenders for this work.

5. The tenders which are not accompanied by the earnest money or proof of earnest money or do not strictly follow the technical requirement, are liable to be rejected summarily.
6. Tenders quotations which are dependent upon the quotations of another tender shall be summarily rejected.
7. The tender of the bidders who does not satisfy the qualification in the bid documents are liable to be rejected summarily without assigning any reason and no claim what so ever on their account will be considered.

SECTION -2

INSTRUCTIONS TO BIDDERS

1. **Eligible bidders**

The invitation to bid is to such Entrepreneurs/individuals who possess adequate financial, managerial and technical capabilities for undertaking the task of toll fee collection in terms of this bid.

The Bidder may be an individual or a Proprietary firm or Partnership Firm or a Private or a Public Limited Company or a joint venture or Consortium of such Companies duly incorporated, registered under the existing rules.

Following are the pre-requisites for eligible bidders;

- i) Property certificate for minimum value of **Rs.28.00 Lac only** obtained from Mandal Revenue Officer in the State of Haryana or equivalent Government office in other State or certificate from the bank indicating the bank balance of **Rs.28.00 Lac only**. However, value of property and bank balance can be combined for achieving minimum value **Rs.28.00 Lac only** or evidence of Average Annual financial turn over for the last 3 years duly verified by Chartered Accountant of **Rs.1.10 Crore only** should be furnished as tabulated below:-

| Sr. No. | Year | Turn over (Rs. In lacs) |
|---------|---------|-------------------------|
| 1 | 2008-09 | |
| 2 | 2009-10 | |
| 3 | 2010-11 | |

Note: *Property certificate should not be older than 1 year prior to last date for submission of EMD.*

- ii) Income Tax clearance certificates/income tax statements for last three years. *In case of non income tax payee such as agriculturalist an affidavit shall be submitted*
- iii) Photo identity proof.
- iv) The bidder should not be involved in any police case regarding over charging or mis-management of toll operation and Affidavit from the bidder that there is no criminal case filed against him for over charging of toll rates.
- v) Partnership Deed/Joint Venture Agreement /Certificate of company, *(Individuals would submit an undertaking that they do not fall under this category).*

- vi) Affidavit from each of the partners of Joint Venture/Consortium formed for undertaking the franchising of toll collection rights that they shall be mutually and severally liable of the defaults of the franchising company. *(Individuals/others would submit an undertaking that they do not fall under this category).*
- vii) Power of Attorney of the authorized signatory to sign the bids and also to enter into negotiations/communications with the Corporation. *(Individuals would submit an undertaking that they do not fall under this category).*
- viii) Bidder debarred /black listed by any organization/institution/ Board/Corporation/ PSU of Central Govt. or any State Govt. would not be eligible for participation in the bidding process.

2. **(A) Cost of bidding**

The bidder shall bear all costs associated with preparation and submission of his bid, HSRDC will in no case be responsible or liable for any such cost, regardless of the conduct or outcome of the bidding process.

(B) Pre bid meeting

Pre bid meeting open to all Entrepreneurs / Agents who desire to submit will be held on **24.05.2012 at 11:30 hours** in the O/o Executive Director, Haryana State Roads & Bridges Development Corporation Ltd., **Bays No. 13-14, Sector-2, Panchkula** wherein the Entrepreneurs / Agents will have an opportunity to obtain information / clarifications regarding the scope and conditions provided in the bid documents.

3. **ASSESSMENT OF FEE REVENUE AND RESTRICTION ON PLACE OF COLLETION OF FEE:**

- (i) The bidder is advised to visit the Fee collection site to make an assessment of the fee revenue based on its own estimation at its own responsibility and expense and may obtain any other information from its own sources that may be required by the bidder for preparing the bid and entering into Contract for collection of fee. The Corporation does not guarantee extent of fee revenue during the contract period.
- (ii) The bidder recognizes the fact that there are number of lateral entries to the section of the Highway/road for which fee is to be collected. The successful bidder will not be entitled to (a) close and (b) demand closure whatsoever, of any such entry. Thus, the bidder recognizes that all toll able traffic may not pass through the fee collection booth or fee plaza.

- (iii) During the contract period, the successful bidder cannot ask for collection from any other place, for whatever reason. Under all circumstances, fee collection shall be only from the place specifically provided in the bid invitation notice. The bidder specifically recognises this condition and must bid only if this is acceptable.

4. **Toll Plaza**

The bidder will be required to make suitable arrangement for construction of toll plaza **which shall include construction of one Toll booth per lane with minimum clear internal dimension of 5' x 4' constructed in brick masonry duly plastered from inside and pointing should be done on the outer surface. The slab should be casted in RCC with a minimum 9' height. If the contractor does not construct the Toll Booth the same shall be constructed by the Department and a recovery of Rupees Twenty Five Thousand per booth shall be made from the contractor. This construction shall be** as per the requirement at toll point to the satisfaction of the Managing Director, HSRDC or his authorized representative.

5. **Toll rates**

Toll rates applicable and chargeable on different categories of vehicles are given in Schedule under section 7.

6. **Language of Bid**

All correspondence and documentation relating to the bid between the bidder and the HSRDC shall be written in English language.

7. **Validity of Bid**

The bids shall be valid for 180 days from the last date of manual/physical submission of EMD.

8. **The Bid**

Technical and financial bids shall be submitted online in separate sealed Envelopes TI & CI, for franchising toll collection at **toll point on UKLANA TOHANA MUNAK ROAD (TP-22) for a period of one year**

The details of the bids shall be as follows: -

8.1 Envelope ED: Earnest Money Deposit Envelope

Bid Security of **Rs5.50 Lac (Rs. Five Lac Fifty thousand only)** in one of the forms mentioned below as per guidelines approved by Board of Directors (**Annexure-I**) pledged in favour of Managing Director, HSRDC along with the certificate of the concerned Bank Manager that the EMD can be encashed at any time by the Managing Director, HSRDC which shall be valid up to 90 days beyond the validity of bid. And also shall upload the scan copy of EMD mandatorily online in Envelope code ED

- a) *Deposit-at-Call Receipt from any scheduled Indian bank or a foreign Bank located in India and approved by the Reserve Bank of India.*
- b) *National Savings Certificates issued by Indian Post Office.*
- c) *Bank Guarantee as per guidelines approved by Board of Directors (Annexure-I)*
- d) *Fixed Deposit Receipt, a certified cheque or an irrevocable letter of credit issued by any scheduled Indian Bank or a foreign bank approved by Reserve Bank of India.*

8.2 Envelope TI : Technical Bid shall be submit mandatorily online (Scan copy of Original Documents)

- a) **For Individuals or Proprietary Firm or Partnership Firm or a Private or Public Limited Company or a joint venture or Consortium of such Companies.**

Property certificate for minimum value of **Rs. 28.00 Lac only** obtained from Mandal Revenue Officer in the State of Haryana or equivalent Government office in other State or certificate from the bank indicating the bank balance of **Rs.28.00 Lac only**. However, value of property and bank balance can be combined for achieving minimum value **Rs. 28.00 Lac only** or evidence of Average Annual financial turn over for the last 3 years duly verified by Chartered Accountant of **Rs. 1 Crore 10 Lac only** should be furnished as tabulated below:-

| Sr. No. | Year | Turn over (Rs. In lacs) |
|---------|---------|-------------------------|
| 1 | 2008-09 | |
| 2 | 2009-10 | |
| 3 | 2010-11 | |

- ii) Income Tax clearance certificates/income tax statements for last three years. *In case of non income tax payee such as agriculturalist an affidavit shall be submitted.*

- iii) Photo identity proof.
- iv) Partnership Deed/Joint Venture Agreement /Certificate of company. (*Individuals would submit an undertaking that they do not fall under this category*).
- v) Affidavit from each of the partners of Joint Venture/Consortium formed for undertaking the franchising of toll collection rights that they shall be mutually and severally liable of the defaults of the franchising company. (*Individuals would submit an undertaking that they do not fall under this category*).
- vi) Power of Attorney of the authorized signatory to sign the bids and also to enter into negotiations/communications with the Corporation. (*Individuals would submit an undertaking that they do not fall under this category*).
- vii) Affidavit from the bidder that there is no criminal case filed against him for over charging of toll rates
- viii) Affidavit from the bidder that he is not debarred/ black listed by any organization /institution / Board / Corporation / PSU of Central Govt. or any State Govt.

8.3 Envelope CI : Price Bid

Financial offer/ priced bid in the form of Price Bid contained in the Bidding document under section 4.

9. Bid Security

- 9.1 The bidder shall furnish, as a part of his bid, a bid Security amounting to **Rs 5.50 Lac (Rupees Five lac fifty thousand only)** in the form of one of the form mentioned in clause 8.1 of Section-2 and as per guidelines approved by Board of Directors (**Annexure-I**) The Bank Guarantee should be pledged in favour of Managing Director, HSRDC along with the certificate of the concerned Bank Manager that the BG can be encashed at any time by the Managing Director, HSRDC which shall be valid up to the validity of bid.
- 9.2 The bid security of un-successful bidders will be returned by the HSRDC without any interest within 15 days of expiry of the validity of bids or after the highest bidder enters into Agreement with the HSRDC whichever is earlier.
- 9.3 The bid security shall be forfeited
 - (a) If the bidder withdraws or modifies his bid/offer after the last date and time for the receipt of bids during the period of bid validity or extended validity period; or
 - (b) In the case of successful bidder, fails within the specified period of 21 days to:-
 - i) Furnish the required security deposit and deposit first installment in advance alongwith T.C.S. @ 2 % or as applicable from time to time; and

ii) Sign the Agreement

- 9.4 HSRDC may at the successful Bidder's option adjust the amount of Bid Security in the amount of Security deposit provided the Bank Guarantee is got converted to Security Deposit and the validity is got extended upto the date of validity of Security deposit indicated in the bid documents. The bid security shall be adjusted or refunded only when the contractual agency has installed boards and constructed toll plaza as per provision in agreement or deposited **Rs. 5.50 lacs** per toll point in lieu of that.
- 9.5 HSRDC may at its discretion, extend the deadline for submission and opening of bids by issuing addendum.
- 9.6 The dues of bidders lying with HSRDC can be adjusted against bid security if the bidder requests in writing for the same or as per desire of HSRDC.
10. **Clarification of Bids**
To assist in examination and evaluation of bids, HSRDC may at its discretion, ask the Bidder for any clarification of his bids, but no downward change in the Bid price shall be sought, offered or permitted.
11. **Receipt of Bids**
Complete bids should be received as per the key dates given in Detail Notice Inviting Tender Section-1 (ii).
12. **Bid evaluation**
Following procedure will be adopted for evaluation of bids:
- 12.1 **Opening of technical bid**
The Technical Bids shall be opened at the time and date prescribed in Key dates of Detail Notice Inviting Tender, Section-1 (ii).
- 12.2 **Opening of the price bid**
The Financial Bids of the bidders who qualify technically shall be opened at the time and date prescribed in Key dates of Detail Notice Inviting Tender, Section-1 (ii).
- 12.3 **Conditional Bid will be rejected outright by HSRDC**
13. **Award of Toll fee collection rights**
- 13.1 The bidder whose price bid is found highest shall be declared as the successful bidder after negotiation if needed . However, the successful bidder may be required to furnish more information as may be required by HSRDC.

13.2 Notwithstanding the above, HSRDC reserves the right to accept or reject any Bid and to annul the bidding process and reject any or all the bids, at any time prior to award of the fee collections rights, without thereby incurring any liability to the affected bidder or without any obligation to inform the affected bidders on the grounds on the basis of which HSRDC has rejected the Bid(s). No reasons shall be assigned to it.

14. **Notification of Award**

(a) Prior to expiration of the period of bid validity prescribed in the bid documents, the HSRDC will notify the successful bidder in writing that his bid has been accepted. This letter of HSRDC (hereinafter called the Letter of Acceptance) shall specify the amount, which the successful bidder shall pay to it during the **one year** period and the necessary formalities to be completed by the successful bidder before signing the Agreement.

Within 21 days of date of issue of the letter of Acceptance, the successful bidder shall furnish to the HSRDC, security deposit in the form of one of the form mentioned in clause 8.1 of Section-2 and as per guidelines approved by Board of Directors (**Annexure-I**) pledged in favour of Managing Director, HSRDC along with the certificate of the concerned Bank Manager that the EMD can be encashed at any time by the Managing Director, HSRDC which shall be valid up to 90 days beyond the expiry of agreement for an amount equivalent to 15% amount of total contract amount of **one year** in favour of Managing Director, Haryana State Roads & Bridges Development Corporation for due observance of the terms and conditions contained herein and the performance of his obligations pursuant to the said bid for the period of **one year**. If the successful bidder desires that the bid security be adjusted towards the security deposit, he will have to get the EMD converted to security deposit and the validity of Bank Guarantee extended up to the date of validity of the Security deposit and he will have to remit the balance amount towards the security deposit. The validity of the Security deposit should be for a period beyond 90 days of the expiry of the Contract period i.e. tolling period. He will have to meet the requirements of clause 9.4 also.

- (b) (i) The Corporation shall also be competent to utilize the said Performance Security against any loss or damage caused to the property of the Corporation by any act of omission and/or commission by the Contractor or its agents and servants or adjust it towards any claim of the Corporation.
- (ii) The Contractor undertakes that, in case of any default on its part to perform and

observe any of the covenants, conditions or provisions contained in this Contract, it shall be lawful for the Corporation in its absolute discretion to forfeit the whole or any part the said Performance Security, without prejudice to any other remedy that the Corporation may have against the Contractor under this Contract or under general law for such breach.

- (c) The amounts lying with the Corporation towards the performance security shall not be adjusted towards instalments due to the Corporation from the Contractor including the instalment for the last month of the initial period **for a period of one year.**

15. **Deposit of first installment**

Entrepreneur/bidder shall be required to deposit first installment (and 2nd installment also, if applicable as per Note given below) in advance of Rs. _____ only alongwith T.C.S @ 2% or as applicable from time to time through Bank Draft in favour of Managing Director, Haryana State Roads & Bridges Development Corporation Ltd. payable at Panchkula within 21 days from the date of issue of Letter of Acceptance.

Note – If the days of that month counted from the date of start of toll are less than Ten, then the 1st & 2nd installments alongwith TCS @ 2% or as applicable shall have to be deposited in advance within 21 days from the date of issue of letter of from time to time acceptance.

16. **Signing of Agreement**

After furnishing Security deposit and depositing first installment (& 2nd installment also, if applicable as per clause: 15) in advance alongwith T.C.S @ 2% or as applicable from time to time & also depositing post dated cheques for all the balance monthly installments as per table-I to HSRDC within 21 days from the date of issue of Letter of Acceptance, the successful bidder should also sign an Agreement in the form of Agreement contained in the bidding document within 21 days from the date of issue of Letter of Acceptance.

Table-I

| Name of Installment | Amount | Due date |
|--|--|---|
| 1 st (2 nd also, if applicable as per Note) | _____ + TCS @ 2% or as applicable from time to time. | Within 21 days of issue of letter of acceptance |
| Balance monthly installments except last. | _____ + TCS @ 2% or as applicable from time to time | Every 1 st date of that month |
| Last Installment | _____ + TCS @ 2% or as applicable from time to time | 1 st date of last month of Agreement period. |

17. For any dispute, the jurisdiction of the court will be at **Panchkula**. No suit will be filed outside the jurisdiction of Court at **Panchkula**.
18. Any false or incorrect information or incorrect affidavit will entail forfeiture of earnest money, security deposit or any other money paid by the Entrepreneur.
19. The bidder before submitting his bid, take into account and provide for payment which he has to make under the provisions of various taxation laws like **Income Tax Act and Sales Tax Act etc.**
20. The bidder shall quote the amount in figures as well as in words. If there is any discrepancy in the amount in figures and in words, then the amount quoted in words will govern.
21. The bidder shall not submit more than one bid. If he submits more than one bid, only the highest bid will be considered.

SECTION-3

Definitions

1. **Bidder/Entrepreneur/ Agent:** Means individual or firm or Company or Joint Venture, who bids for collection of toll from the toll facility.
2. **Notice Inviting Bids :** This means notice for inviting bids for the collection of toll.
3. **Bid Document :** This means complete bid documents including Instructions to Bidders, Form of Bid and Form of Agreement including other relevant details.
4. **Contract/ Agreement:** Means the legal binding document executed between the Entrepreneur/agent and Managing Director, HSRDC.
5. **HSRDC:** Means Haryana State Roads & Bridges Development Corporation Limited.
6. **Managing Director :** Means the Managing Director of HSRDC.
7. **Toll Facility :** Means the Road on which toll is proposed to be levied.
8. **Toll Point:** Means **the toll point on UKLANA TOHANA MUNAK ROAD (TP-22)** where toll is proposed to be collected.
9. **Bank:** Means any Bank given in **Annexure-I**.

SECTION-4**FORM OF BID**

Sr. No. _____

From

Full Name _____

Age _____

Address _____

i) Telegraphic Address, if any _____

ii) Telephone Number, if any _____

To

**Managing Director,
Haryana State Roads and Bridges
Development Corporation Ltd.,
Panchkula.**

**SUBJECT: BID FOR APPOINTMENT AS ENTREPRENEUR / AGENT FOR
COLLECTION OF TOLL AT TOLL POINT ON _____.**

Sir,

1. Pursuant to your Notice Inviting Bid No. _____ Dated _____ I/we hereby submit my/ our bid for being appointed as Entrepreneur/your Agent for the collection of toll from the **toll point on _____ for a period _____** to be counted from the next day of date of execution of Agreement.
2. I/We offer to pay Haryana State Roads & Bridges Development Corporation Limited. following sums as and by way of our offer as Entrepreneur/your Agent for the collection of toll from the Toll point as indicated in Para 1 above. During the period of _____ the following amount shall be payable to Haryana State Roads & Bridges Development Corporation Limited.

Total bid price offered for period of one year Rs. _____

(To be deposited in 12 monthly installments of Rs. _____ each) plus

T.C.S @ 2% or as applicable from time to time.

3. I/We will deposit first installment (2nd installment also, if applicable as per Note given below) in advance of Rs. _____ only alongwith T.C.S @ 2% or as applicable from time to time through Bank Draft in favour of Managing Director, Haryana State Roads & Bridges Development Corporation Ltd. payable at Panchkula within 21 days from the date of issue of Letter of Acceptance.
Note – If the days of that month counted from the date of start of toll are less than Ten, then the 1st & 2nd installments alongwith TCS @ 2% or as applicable shall have to be deposited in advance within 21 days from the date of issue of letter of acceptance (& 2nd installment also, if applicable as per clause: 15)
4. I/We will deposit security deposit (equal to 15% of Contract Amount) in the shape of Bank draft in favour of Managing Director, Haryana State Roads & Bridges Development Corporation Limited payable at Panchkula or Bank guarantee in favour of Managing Director, Haryana State Roads & Bridges Development Corporation Limited with in 21 days from the date of issue of Letter of Acceptance.
5. I/We will also deposit post dated cheques for all the balance monthly installments within 21 days from the date of issue of letter of Acceptance.
6. I/We will deposit all the monthly installments on due date. In case cheque is encashed, I / We will bear the cheque clearance charges alongwith interest from due date @ 0.06% per day.
7. I/We have thoroughly read understood terms and conditions of tender for being appointed as Entrepreneur/Agent for the aforesaid purpose and the terms and conditions and will abide by them.
8. I/We agree to keep my/our this bid open for acceptance up to 90 days after the last date of receipt of bid. I/We shall be bound by the communication of acceptance of this bid dispatched within the aforesaid time.
9. As required by the terms and conditions of Bid, I/We enclose herewith Bid Security of Rs _____ (Rupees _____ only) in the form of bank guarantee No. _____ dated _____ of _____ bank on branch _____ at _____ valid up to _____ in favour of Managing Director, Haryana State Roads & Bridges Development Corporation Limited.
10. I/We agree that the full value of Bid Security will be forfeited without prejudice to any other right or remedy available to the Managing Director or his successor in office or his representative, should I/We:
 - i) Withdraw or modify my/our bid/offer after the last date and time for the receipt of bids during the period of bid validity or extended validity period; or

- ii) Fail to deposit Security deposit and first installment in advance within 21 days from the date of issue of Letter of Acceptance.
- iii) Fail to sign the Contract agreement also within 21 days from the date of issue of Letter of Acceptance.

11. The names and addresses of the partner of our firm/Directors of our company are as follows:

Name _____ Address

- 1.
- 2.
- 3.
- 4.

A copy of our Deed of partnership duly certified as is enclosed.

OR

Our company is a private /public limited company registered under The Companies Act, 1956 and its registered office is situated at _____ A copy of the Memorandum and Articles of Association of our company duly certified as true is enclosed.

Yours faithfully,

(SIGNATURE OF Bidder)
Capacity in which signing

Name:

Address:

Registered Speed post**SECTION-5****LETTER OF ACCEPTANCE**

**From: Managing Director,
Haryana State Roads & Bridges
Development Corporation Limited,
Bays No. 13-14, Sector-2,
Panchkula.**

To _____

Memo No. HSRDC/ _____ Dated _____

**SUBJECT: BID FOR APPOINTMENT AS ENTREPRENEUR/AGENT FOR
COLLECTION OF TOLL AT TOLL POINT ON _____.**

Reference: - Your bid/offer dated _____ for the work under subject.

This is to inform you that your Bid/Offer dated _____ mentioned under reference for the appointment of Entrepreneur/Agent for collection of toll at **toll point on** _____ for a period of one year for a consideration of Rs. _____ (Rs. _____ only) now called **Contract amount plus T.C.S. @ 2% or as applicable from time to time** has been accepted subject to the following conditions coupled with all other conditions of Bid documents:

1. Total Contract amount **for a period of one year** payable by you is Rs. _____ (Rupees _____) plus T.C.S. @ 2% or as applicable from time to time.
2. An amount of Rs. _____ (15% amount of contract amount for a year) is payable by you as Security Deposit for due performance of contract agreement to be executed. This amount can be paid by you in the form of Bank draft in favour of Managing Director, Haryana State Roads & Bridges Development Corporation Limited payable at Panchkula or Bank guarantee in favour of Managing Director, Haryana State Roads & Bridges Development Corporation Limited with in 21 days from the date of issue of Letter of Acceptance.

In addition to above, you are requested to deposit 1st installment (& 2nd installment also if applicable as per Note below) in advance of Rs. _____ (Rupees _____ only) alongwith T.C.S @ 2% or applicable from time to time

in the form of bank draft in favour of Managing Director, Haryana State Roads & Bridges Development Corporation Limited payable at Panchkula. This amount is payable by you within 21 days from the date of issue of Letter of Acceptance i.e. by _____, to enable you to execute and sign the agreement with HSDRC.

Note-I – If the days of that month counted from the date of start of toll are less than Ten, then the 1st & 2nd installments alongwith TCS @ 2% or as applicable shall have to be deposited in advance within 21 days from the date of issue of letter of acceptance.

The remaining installments should be deposited as per table given below:

| Name of Installment | Amount | Due date |
|--|---|---|
| 1 st (2 nd also, if applicable as per Note) | _____ + TCS @ 2% or as applicable from time to time | Within 21 days of issue of letter of acceptance. |
| Balance monthly installments except last. | _____ + TCS @ 2% or as applicable from time to time | Every 1 st date of that month. |
| Last Installment | _____ + TCS @ 2% or as applicable from time to time | 1 st date of last month of Agreement period. |

In case of default to pay any installment by the due date, same can be paid within next 30 days but along with interest calculated @ 0.06% of the due amount for each day of delay.

You will also deposit advance post dated cheques for all the balance monthly installments of contract period as under:

| Name of installment | Advance post dated cheque | | Name of Bank |
|---------------------|---------------------------|--------|--------------|
| | No. & date | Amount | |
| 2 nd | | | |
| 3 rd | | | |
| 4 th | | | |
| 5 th | | | |
| 6 th | | | |
| 7 th | | | |
| 8 th | | | |
| 9 th | | | |
| 10 th | | | |
| 11 th | | | |
| 12 th | | | |

In case the entrepreneur / Agent fails to deposit the installment by due date i.e. by 1st date of that month then these post dated cheques shall be deposited in bank for encashment. The cheque clearance charges alongwith interest from due date @ 0.06% per day shall be the liability of the Entrepreneur/ Agent and shall be recovered from him.

Further, if any installment is not paid within 30 days after due date along with interest or cheque is not encashed within 30 days after due date; your contract agreement can be terminated without any further notice. In such an event without, prejudicing or diluting our right/ remedy to any other claim or relief your Security deposit, installments of contract amount paid by you can stand forfeited to HSRDC without any claim from you. Authorization issued to you for collection of toll will stand cancelled and withdrawn and your entitlement to collect toll will cease. You will be stopped to make any further collection of toll and the site of toll point will be taken over by the Managing Director, HSRDC, who will start subsequent collection of toll in the way as deemed fit.

3. Stamp duty @ 1.5% of the contract value is leviable on the stamp papers to be purchased from Haryana State or as applicable from time to time.
4. Your security deposit of Rs. _____ to be taken as security for proper performance of contract agreement will be refunded on your request after one month after expiry of agreement period provided, you have paid all the money due to HSRDC and nothing being recoverable from you. If any dues are recoverable from you, it will be adjusted from your security deposit before it is refunded.
5. The consideration fixed for your contract entitles you to charge toll from motor vehicles specified in the schedule passing at **toll point on _____ for a period of one year** at the rates indicated in the schedule appended in the bid documents.
6. After payment of security deposit and 1st installment alongwith T.C.S. @ 2% or as applicable from time to time you are required to execute and **sign contract agreement on the stamp paper of the value of Rs _____ (1.5% of contract value)** to be purchased from Haryana State with HSRDC as envisaged in para 3 above within a period of 21 days also counted from the date of issue of this letter.
7. Failure on your part to deposit Security deposit and First installment in advance alongwith T.C.S. @2% or as applicable from time to time with in 21 days from the date of issue of Letter of Acceptance or failure to sign the agreement also with in 21 days from the date of issue of Letter of Acceptance, will render this Letter of Acceptance as cancelled and withdrawn and without prejudicing or diluting our rights and relief otherwise due, bid Security and other money paid by you to

HSRDC in this connection shall stand forfeited to HSRDC without any claim from you.

8. After signing of agreement, you will be issued authorization for collection of toll from the specified vehicles as per schedule rates and as per terms and conditions of bid documents for strict observance by you.
- 9 The contract agreement signed between you and the Managing Director (For and on behalf of Haryana State Roads & Bridges Development Corporation Limited) shall be legally binding on you and shall remain operative **for a period of one year** calculated from the date specified in the agreement to be executed for a legally binding contract with timing deemed to be 0.00 hours.

**Dy. General Manager,
for Managing Director,
Haryana State Roads and Bridges
Development Corporation Ltd.
Panchkula.**

FORM OF AGREEMENT

Haryana State Roads & Bridges Development Corporation Limited

Name of Entrepreneur/Agent. _____

Name of work _____

Contract No HSRDC/ _____

THIS AGREEMENT MADE this _____ the _____ day of _____ and _____ between _____ hereinafter referred to as Entrepreneur/Agent of the one part and the Managing Director, Haryana State Roads & Bridges Development Corporation Limited hereinafter referred to as "HSRDC"(which expression shall unless the context does not so admit include his successors and assignees) of the other part.

Whereas Haryana Government has declared **toll point on (as given in section-3, Clause-8) as "Toll facility."**

Whereas under the provision of section 2 of the Haryana Mechanical Vehicles (Levy of Toll) Act, 1996 (Haryana Act No 9 of 1996) Haryana Government is empowered to levy and collect toll on Motor vehicles passing through the toll point on (as given in section-3, Clause-8 of bid document).

And whereas under the provisions of section 3 of the said Act, the Haryana Government is also empowered to levy toll on the said road at such rate and for such period as the Government may, from time to time, by notification in the official Gazette declare.

And whereas under the provisions of the said Act, the Government is further empowered to collect the toll so levied on the said road through the Entrepreneur/Agent, such Entrepreneur/Agent or his servants being deemed to be the persons empowered to collect toll under the said Act. Haryana Government under the provisions of said Act has entrusted tolling rights to Haryana State Roads & Bridges Development Corporation Limited

And whereas with a view to select and appoint a suitable Entrepreneur/Agent to collect toll levied on the said road, HSDRC had invited bids/offers

And whereas the Bid/offer made by the Entrepreneur/Agent for collection of toll on the said road **for a period of one year** commencing from the of date specified in the letter of Acceptance or Authorisation from the Managing Director (for and behalf of Haryana State Roads & Bridges Development Corporation Limited of execution of Agreement, to collect such toll has been

accepted by the HSRDC and the HSRDC has agreed to appoint the Entrepreneur/Agent to collect toll on the said road on certain terms and conditions.

NOW THIS AGREEMENT WITNESSTH AS FOLLOWS :-

1. In the agreement words and expressions shall have the same meaning as are assigned to them as per general conditions of contract hereinafter referred to.
2. The following documents shall be deemed to form and be construed as part of this contract agreement in the following order of priority.
 - i) Agreement form including conditions duly completed, signed and executed by the Entrepreneur/Agent and Managing Director (For and on behalf of Haryana State Roads & Bridges Development Corporation Limited)
 - ii) Letter of Acceptance.
 - iii) Schedule of Toll Rates
 - iv) Form of Bid duly completed and signed by Entrepreneur/Agent
 - v) Notice Inviting Bid and Instructions to Bidders.
 - vi) Definitions.
 - vii) Duties and functions to be performed by the Entrepreneur/Agent Schedule-1, Schedule-2, Schedule-3 and Forms 1 to 3.
 - viii) Mutually agreed terms and conditions if any

WHEREAS, the Entrepreneur/Agent has agreed to make payment of Rs. _____ only plus T.C.S. @ 2% or as applicable from time to time to HSRDC in installments as prescribed in the contract for a period of _____ in consideration of his appointment as Entrepreneur/Agent to collect toll.

AND WHEREAS, it has been agreed that the said sum of Rs. _____ only as deposited by the Entrepreneur/Agent as Security Deposit will not carry any interest.

AND WHEREAS, the parties are desirous of recording the terms and conditions on which the Entrepreneur/Agent has been authorized by the HSRDC to collect toll at **toll point on** *(as given in section-3, Clause-8) for a period of one year.*

In consideration of the promises, the HSRDC do hereby appoint the Entrepreneur/Agent and Entrepreneur/Agent do hereby agree to act as the Entrepreneur/Agent of the HSRDC for collection of the toll on the said toll point **for a period One year** from the date specified in the letter of acceptance or authorization from the Managing Director (For and on behalf of Haryana

State Roads & Bridges Development Corporation Limited) authorizing the Entrepreneur/Agent to collect toll on the said road.

Provided that, the HSRDC may with the concurrence of the Entrepreneur/Agent may extend the period of contract for such further period, which may extend up to three months as to in its discretion thinks fit, but on the existing terms and conditions contained in this Agreement. However pro-rata payment shall be made by the Entrepreneur/Agent for the number of days based on the rate of monthly installment.

Provided always that in no event the Entrepreneur/Agent shall have the right to demand continuance of contract agreement beyond the period of contract prescribed in this agreement or extended period of contract as the case may be.

AND WHEREAS the Contractor undertakes to:

- (a) Comply with all the provisions of the Employees Provident Fund and Miscellaneous Provisions Act, 1952;
- (b) Pay to all its personnel deployed as per the Minimum Wages Act, 1948 and
- (c) Comply with all the provisions, duties and obligations imposed upon it by any law for the time being in force as may be applicable.

AND WHEREAS, the Entrepreneur/Agent in pursuance to the terms and condition of the contract has deposited the first installment (and second installment also, if applicable as per Note-I) in advance of Rs. _____ only alongwith T.C.S. @ 2% or as applicable from time to time.

Note-I – If the days of that month counted from the date of start of toll are less than Ten, then the 1st & 2nd installments alongwith TCS @ 2% or as applicable shall have to be deposited in advance within 21 days from the date of issue of letter of acceptance.

Whereas the Entrepreneur/Agent do hereby agree to pay regularly the following installments as given under by the specified due dates.

| Name of Installment | Amount | Due date |
|--|--|--|
| 1 st (2 nd also, if applicable as per Note) | _____ + TCS @ 2% or as applicable from time to time | Within 21 days of issue of letter of acceptance |
| Balance monthly installments except last. | _____ + TCS @ 2% or as applicable from time to time | Every 1 st date of that month |
| Last Installment | _____ + TCS @ 2% or as applicable from time to time | 1 st date of last month of Agreement period. |

AND WHEREAS, the Entrepreneur/Agent hereby agrees that all the above mentioned installments alongwith T.C.S. @ 2 % or as applicable from time to time shall be paid in the shape of demand drafts drawn on any Nationalized Bank/ ICICI / HDFC/ UTI/ IDBI Bank, payable at Panchkula, in favour of Managing Director, Haryana State Roads & Bridges development Corporation Limited.

Further the Entrepreneur/Agent hereby agrees that he will pay to the HSRDC all installments alongwith T.C.S. @ 2 % or as applicable from time to time on due dates in advance as aforesaid and that further he will have no claim for interest on these installments paid in advance.

And whereas, in case of default to pay any installments by due date the same will be paid along with interest calculated @ 0.06% per day of delay. Further in case any installment along with interest is not paid within 30 days counted from the due date or the cheque is not encashed within 30 days after due date, then the contract agreement can be terminated without any further notice. In such event without prejudicing the rights and other remedies available to the Haryana State Roads & Bridges development Corporation Limited, the Security Deposit and all installments of contract amount already paid shall stand forfeited without any claim from the agency.

Further any authorization letter for collection of toll issued shall be treated as cancelled and withdrawn. Further more Haryana State Roads & Bridges development Corporation Limited will be at liberty to take over the site and start collection of toll as deemed fit.

And the Entrepreneur/ Agent has also deposited advance posted dated cheques for all the balance monthly installments of contract period as under:

| Name of installment | Advance post dated cheque | | Name of Bank |
|---------------------|---------------------------|--------|--------------|
| | No. & date | Amount | |
| 2 nd | | | |
| 3 rd | | | |
| 4 th | | | |
| 5 th | | | |
| 6 th | | | |
| 7 th | | | |
| 8 th | | | |
| 9 th | | | |
| 10 th | | | |
| 11 th | | | |
| 12 th | | | |

In case the entrepreneur / Agent fails to deposit the installment by due date i.e. by 1st date of that month then these post dated cheques shall be deposited in bank for encashment. The cheque clearance charges alongwith interest from due date @ 0.06% per day shall be the liability of the Entrepreneur/ Agent and shall be recovered from him.

(The post dated cheques of those Entrepreneur/Agents who deposited the monthly installment on due date shall be returned back).

And whereas Entrepreneur/Agent hereby agrees that he shall collect toll at the rates mentioned in the schedule as given in the Schedule of Toll Rates in Section-7.

3. AND WHEREAS, the Entrepreneur/Agent do hereby agree :

That any sum of money due or payable to the Entrepreneur/Agent including Security Deposit returnable to the Entrepreneur/Agent under this, may be appropriated by the HSRDC to set off against any claim of HSRDC for the payment of any sum of money arising out of or under any other contract made by the Entrepreneur/Agent, with the HSRDC

4. And whereas the Entrepreneur/Agent hereby agrees to the further terms and conditions.

i) The Entrepreneur/Agent shall not assign or sublet without the written approval of the Managing Director, Haryana State Roads & Bridges Development Corporation Limited. Employment of labour on piece rate basis shall not however be deemed sub-letting. If the Entrepreneur/Agent shall assign or sublet the contract or attempts to do so without the approval as aforesaid or becomes insolvent or commence any solvency proceedings or makes any composition with his creditors or attempt to do so or if any bribe, gratuity, gift, loan, perquisite, reward, pecuniary or otherwise, shall either directly or indirectly be given, promised or offered by the Entrepreneur/Agent or by any of his servants or agents to any public officer or office or employment, or if any such officer or person shall become in any way directly or indirectly interested in the contract, the Managing Director, HSRDC may absolutely there-upon terminate the contract and in the event of said course being adopted, the consequences specified therein shall ensue.

ii) If the Entrepreneur/Agent being natural persons die or being natural person or a partnership firm is adjudged insolvent or commits any act of insolvency or being a limited company is ordered to be wound up or makes arrangements with its creditors or fails to observe any of the provisions of this contract, the contract shall, forthwith, stand terminated, without prejudice to any other rights or remedies of the HSRDC under this contract. If the Entrepreneur/Agent or servants of the

Entrepreneur/Agent not being limited companies are convicted of any offence under the prohibition Act. or opium smoking Act. or the Narcotic Drugs and Psychotropic substances Act, the HSRDC shall, at its discretion have the right to terminate the contract without notice and in that event no compensation shall be payable by the HSRDC to the Entrepreneur/Agent on account of such termination of the contract.

- iii) However, neither party shall be liable to the other for any loss or damage occurred/ caused by or arising out of acts of God and in particular, “unprecedented floods”, resulting in disruption of traffic on the road, volcanic eruption, earth quake or other convulsion of nature, and other acts, such as, but not restricted to invasion, the act of foreign countries, hostilities or war like operation before or after declaration of rebellion, Military operation which prevent performance of the contract and which would not have been foreseen or avoided by prudent person and in such cases the decision of Managing Director HSRDC shall be final.
- iv) In the event of any default on the part of the Entrepreneur/Agent to comply with any of the terms of this contract or in the event of termination of the contract by the HSRDC under any provision, the HSRDC shall have the right to forfeit the entire or part amount of Security Deposit, furnished by the Entrepreneur/Agent and to appropriate the Security Deposit or any part thereof in or towards the satisfaction of any claim of the HSRDC or any damage, losses, costs charges or expenses, or otherwise. However, the decision of Managing Director HSRDC shall be final in respect of such damages, losses, costs, charges or expenses or otherwise and binding on the Entrepreneur/Agent.
- v) In the event of the Security Deposit being found insufficient or if the Security Deposit has been wholly forfeited, the balance of the total sum recoverable as the case may be shall be deducted from any sum due to them or which at any time thereafter may become due to the Entrepreneur/Agent under this or any other contract with the HSRDC, should that also be not sufficient to cover the full amount recoverable, the Entrepreneur/Agent shall forthwith pay to the HSRDC on demand the remaining balance due.
- vi) Upon the compliance by the Entrepreneur/Agent with all obligations and requirement under this contract agreement, the deposit or such part thereof, as shall not have been forfeited or appropriated as aforesaid, shall be refunded to the Entrepreneur/Agent.

- vii) HSRDC shall, without prejudice to its any other rights and remedies, be entitled to recover from the Entrepreneur/Agent all amount due or recoverable by HSRDC from him there under as arrears of land revenue under the provisions of law enforce in that behalf.
 - viii) Except where otherwise provided or specified in the contract and subject also to, such power as may be delegated to him from time to time by the Government, the decision of the Managing Director, HSRDC for the time being in charge of the said Toll facility on all questions and matter whatsoever arising out of or in relation to or in connection with this contract or as to the interpretation of any of its provisions or clause/s either during the subsistence of this contract or at any time thereafter shall be final and binding on the parties to this contract.
5. In case of total or complete closure of this toll facility to motor vehicle traffic due to any reason, Entrepreneur/Agent may be granted rebate @ 1/30 of installment amount for each day for the number of the days of admitted closure as certified by the Managing Director, HSRDC subject to the following conditions:
- As soon as the traffic is closed on the toll facility, the Managing Director, HSRDC will be informed telegraphically/email and in writing by the Entrepreneur/Agent and suitable entry made in the record maintained at site on register.
- i) Immediately on the re-opening of traffic Managing Director, HSRDC will be informed telegraphically/email and in writing by the Entrepreneur/Agent and suitable entry instantly being made in the register.
 - ii) Claim for closure for less than 24 hours will not be entertained.
 - iii) The Entrepreneur/Agent shall submit detail of such closure for which he intends to claim rebate, by the 10th day of following month to the Managing Director, HSRDC. If the Entrepreneur/Agent does not submit details of his intended claim by the 10th day of following month, It will be presumed that he has no claim for rebate for the preceding month.
 - iv) The rebate if any after full satisfaction by the Managing Director, HSRDC, will be allowed in the **final installment of** contract money to be paid to the HSRDC by the Entrepreneur/Agent. However, strike by particular category/ categories of vehicles shall not be treated as a total/complete closure of toll facility.
6. i) Toll will be collected by the Entrepreneur/Agent at the scheduled rates as provided in the contract.
- ii) As soon as Managing Director, HSRDC withdraws his authorization, Entrepreneur/Agent will stop collection of such toll.

7. It shall be the responsibility of the Entrepreneur/Agent to protect against accidents on the said road. He shall indemnify the Managing Director, HSRDC against any claim for damage or injury to any person or property resulting from and in the course of the work and also under the provision of the workmen's compensation act.
8. In the event of death or insanity of the Entrepreneur/Agent, the contract may be terminated by notice in writing, pasted at the site and advertised in one issue of local newspaper. All acceptable claims shall thereafter be paid at appropriate rates after recovering all the Entrepreneur/Agent dues to Managing Director, HSRDC, to the persons entitled to receive and give discharge for such payment.
9. It is clarified and agreed to by the parties that all rights of the Managing Director, HSRDC at the site of toll facility are reserved and retained by it and only toll collection rights are being given to the Entrepreneur/Agent.
10. Managing Director, HSRDC shall be entitled to terminate this Agreement at any time.
 - a) Without assigning any reason thereof after giving to the Entrepreneur/Agent fifteen days prior notice in writing and in that event the Entrepreneur/Agent shall not be entitled to claim, recover or receive from the Government any compensation whatsoever on account of such premature termination.
 - b) By giving 15 days notice in writing to Entrepreneur/Agent for breach or non observance by Entrepreneur/Agent any terms or conditions of this agreement for which no specific provision is available separately.
 In the happening of such an event and agreement being terminated, Entrepreneur/Agent will be liable to pay to Managing Director, HSRDC money proportionately calculated @ 1/30 of the monthly installment for each day, the agreement remained in force.
 Further in case of the agreement having been terminated under clause (b) above, the Entrepreneur/Agent will further be liable to pay to HSRDC, out of his security deposit any amount or portion thereof of Security Deposit as deemed appropriate by the Managing Director, HSRDC whose decision will be final and binding upon the Entrepreneur/Agent.
11. Managing Director, HSRDC shall, without prejudice to its any other rights and remedies, be entitled to recover from the Entrepreneur/Agent all amounts due or recoverable by Managing Director, HSRDC from him there under as arrears of land revenue under the provision of law enforce in that behalf.

12. The entrepreneur/agency should install appropriate hoardings/reflective Boards relating to 'User fee,' exempted category, placards etc. as depicted in the enclosed '**Layout Plan**' and details given in **Annexure-2**.
13.
 - a) The Entrepreneur/Agent agrees that he will not charge fee in excess of the prescribed fee rate from any user. If it is found at any time, fee in excess of the prescribed rate has been charged by the Entrepreneur/Agent from any user, such action of the Entrepreneur/Agent shall be construed as misconduct on the part of Entrepreneur/Agent and may result in termination of contract without any notice.
 - b) The Entrepreneur/Agent will make appropriate arrangement for management of the traffic at his own cost and shall ensure that no vehicle has to wait for more than one minute for the purpose of paying the fees.
 - c) The Contractor shall not be allowed to make his own interpretation about a particular type of vehicle attracting a particular rate so as to charge a higher rate from a particular type of vehicles. Decision of the EE/DGM in-charge on such matter shall be final and binding
14. The Entrepreneur/Agent shall furnish to the Managing Director, HSRDC such information as may be required for all categories of employees employed by him.
15. In the event of abandonment of the project by the Entrepreneur/Agent due to his fault or due to bankruptcy or default or for any other reason attributable to him, the Managing Director, HSRDC will be entitled to take over the fee collection gates, cancel this agreement in the manner he deems fit. Further the Managing Director, HSRDC in such a situation will forfeit the security and all other money given by the Entrepreneur/Agent to HSRDC on any account without any claim from him.
16. The Entrepreneur/Agent shall furnish to the Managing Director, HSRDC concerned a list of persons employed by him, for the purpose of collection of fee, along with their educational qualification and experience. The Managing Director, HSRDC may object to employment of any person and shall give notice to this effect. The Entrepreneur shall remove such person under intimation to Managing Director within a period of 24 hours of such notice given by the Managing Director, HSRDC to the Entrepreneur/Agent.
17. The Entrepreneur/Agent shall keep the road open for traffic at all hours under all reasonable conditions except when crossing the road is dangerous and the Entrepreneur/Agent is asked to close traffic.

18. All incidental expenses whether recurring, non recurring, incidental due to collection of toll or receipt book, stationery, dues, wages of his staff etc. will be the liability of Entrepreneur/Agent.

19. DIVERSIONS:

- (a) The Contractor has surveyed the said Section of this toll road and surrounding area including any access or diversion(s) and the Contractor has submitted its bid taking into consideration all such access or diversion(s), whether existing or likely in the future which any road user may opt , inter-alia, to avoid payment of the fee by bypassing the fee collection booths.
- (b) The Contractor undertakes that, it shall not make any claim for any decrease in traffic on the ground of diversion of the traffic, even if such diversion did not exist at the time of submission of the bid by the Contractor.
- (c) The Contractor will not be entitled to (a) close and (b) demand closure by any authority whatsoever, of any lateral entry to the said section of the Highway/road for which fee is to be collected . The Contractor recognizes that all tollable traffic on the said section may not pass through the fee collection booth or fee plaza.

20. REQUIREMENT OF PERSONNEL FOR FEE COLLECTION:

For the purpose of discharging its obligations under this Contract, the Contractor shall deploy adequate number of personnel of such qualification and having undergone such training as may be relevant and considered necessary from time to time by the Corporation to ensure efficient management of entire operations, including free flow of traffic, in or around the plaza including in the fee collection booths.

However, the Corporation reserves the right to serve directions for any change in the number of personal to be deployed by the Contractor, for the purpose of Fee Collection for ensuring free flow of traffic.

21 DEPLOYMENT OF PERSONNEL:

- (a) The Contractor shall ensure that the personnel deployed by it for discharging its duties under this Contract are of good health, of highest integrity, punctual, well dressed and well behaved.
- (b) The Contractor shall furnish to the Corporation a list of persons deployed for the purpose of discharging its obligations under the Contract, containing all the details like their educational qualifications, training undergone, experience, personal residential addresses and recent photographs.

- (c) The uniform of the personnel deployed shall necessarily bear the name of the individual and the name of the Contractor. The uniform shall be such, as may be approved by the Executive Director of the Corporation.
- (d) The Corporation reserves its right to object to the deployment of any personnel for any reason in which case, such person or persons being objected by the Corporation shall be removed by the Contractor forthwith and replaced within a day from such removal.
- (e) The personnel deployed by the Contractor shall not misconduct/misbehave with the members of public and shall observe strict discipline and decency in their behavior.
- (f) The Corporation shall not be liable for any misconduct or misdeeds or any act or incident involving the Contractor or any of its personnel in any criminal or civil case and Contractor alone shall be responsible for consequences and if any such incident takes place, the Contractor shall forthwith intimate the said incident to the Executive Director.
- (g) The Contractor specifically agrees that the personnel deployed by it, will not in any way claim employment with the Corporation. The Contractor shall be solely responsible for any dispute raised by the personnel deployed either during the term of the Contract or thereafter.

22. INTER SE RELATIONS:

- (a) In all circumstances it is clearly understood by the parties that the personnel deployed by the Contractor shall have no connection whatsoever with the Corporation and the relationship of master and servant or employer and employee shall be only between the Contractor and the personnel deployed by it.
- (b) However, if considered necessary, the Corporation shall have every right to enquire and seek documentary evidence from the Contractor, whether all the statutory dues like ESI, EPF, Minimum Wages, Weekly offs, Bonus, Medical Leave, Workmen Compensation and any other entitlements for which the Contractor is liable to provide, are being paid or not or have been paid or not for a particular period.
- (c) In case of any breach by the Contractor in the payment of such statutory dues not necessarily pertaining to its personnel/employees, the Corporation shall be entitled to

adjust the same from the Performance Security and pay such statutory dues to the appropriate Corporation. The Contractor shall replenish the Performance Security within 7 days of the notice by the Corporation. The decisions of the Corporation in this regard shall be final and binding on the Contractor.

23. PENALTY FOR CHARGING EXCESS FEE:

- (a) In case, it is observed and/or established to the satisfaction of the Corporation that the Contractor has charged fee in excess of the prescribed rate, the Corporation may terminate the contract forthwith and/or may impose a penalty of Rs. One Lakh or an amount equivalent of one day's fee receivable by the Corporation, whichever is higher and may provide the Contractor another opportunity of continuing the Fee Collection. However, in no case, the Corporation shall afford more than one opportunity to the Contractor.
- (b) The Corporation also, reserves the right to estimate the excess collection of fee made by the Contractor and recover the same, which will be over and above the penalty imposed and to be recovered from the Contractor.
- (c) The termination under this clause shall make the Contractor liable for unconditional forfeiture of the Performance Security.
- (d) The termination under this clause, in addition to unconditional forfeiture of the Performance Security, shall make the Contractor liable for debarring from assigning any future work with HSRDC and Haryana PWD B&R for a minimum period of 2 years. The other current works shall also be terminated immediately.

24. OPERATIONAL TRANSPARENCY:

The Contractor shall be solely responsible for efficient and transparent working and management of fee collection at all points of time.

- 25 (a) The Contractor undertakes the responsibility of the complete job of fee collection, maintenance of all records, maintaining the cleanliness of fee plazas/fee collection booths and surrounding area etc. and any other duty as may be assigned by the Corporation from time to time.
- (b) The Contractor shall make appropriate arrangement for management of the traffic at its own cost and shall ensure that no vehicle has to wait for more than one minute for the purpose of paying fee. All the lanes shall be kept open at all times irrespective of peak or off peak hours.

- (c) The Contractor specifically undertakes to abide by all the instructions issued by the Corporation from time to time on operational matters and further agrees not to raise any dispute against the same including any additional cost that the Contractor may be required to bear to comply with such instructions.
- (d) The Contractor shall also submit such information in such format which would enable the Corporation to submit information to appropriate prescribed authorities under the various laws applicable.
- (e) The Contractor also agrees to unconditionally abide by such other direction of the Corporation issued by the Executive Director on all operational matters including on deployment of the personnel for the purpose of this Contract.

26. RIGHT OF INSPECTION:

- (a) The Corporation reserves the right to conduct checks including surprise checks at any time, to check/observe/witness the activities of the Contractor including the fee collection Plaza(s) and to monitor or to ensure that any or all the activities including fee collection enunciated by this Contract are being carried out properly by the personnel deployed by the Contractor.
- (b) The Corporation may exercise any check/control to ensure discharge of various obligations by the Contractor under the Contract not limited to following:
 - i) Correctness of the fee charges recovered from users, as prescribed;
 - ii) Issue of proper Receipts to all Vehicles;
 - iii) Maintenance of proper registers including those relating to collection of fee from different type of vehicles ;
 - iv) Monthly remittance of amount due from the Contractor by the prescribed date;
 - v) Maintain Fee Plaza(s) and its appurtenances by the Contractor at his cost and ensure that they are in good running condition;
 - vi) Arrangement for lighting and water are in order; and
 - vii) There is no delay to the traffic due to procedure of collection of fee and also there is no traffic jam at the Fee Plaza(s).
 - viii) Any other check or control as considered appropriate by the Corporation including through its authorised representative.

27 BREACH:

Any breach of the terms and conditions herein contained in this Contract, which may or may not, cause any financial loss to the Corporation shall attract immediate unilateral termination of this Contract by the Corporation, notwithstanding anything contrary contained in any of the Clauses in this Contract.

28. WAIVER:

Failure or neglect by either of the Parties to enforce at any time any of the provisions hereof shall not be deemed to be a waiver of the right. In such an event, the same shall neither affect the validity of the whole or any part of this Contract nor prejudice the rights of Parties from taking subsequent action.

29. ASSIGNMENT:

The Contractor under takes not to assign any right and/or obligation of this Contract to any other person without prior consent of the Corporation in writing.

30. INDEMNITY:

The Contractor shall indemnify the Corporation and its officers, agents and authorized representatives against all liabilities, damages and expenses arising from any claims for damages, suits, proceedings, recoveries, judgments or executions (including, but not limited to litigation costs and expenses and reasonable fees of the Attorney) which may be made or recovered from the Corporation by reason of any acts, omissions (whether negligent or otherwise) or due to willful misconduct of the Contractor including its agents, survivors and personnel.

- 31. The Entrepreneur/Agent on award of collection rights at prescribed rates will have to make suitable arrangements for construction of toll plaza as per requirement at toll point with satisfaction of M.D., HSRDC and maintain the same during the toll period.** The Entrepreneur/Agent shall also install and maintain toll collection barriers. The Entrepreneur/Agent shall also provide reasonable facilities to the toll payers/traffic as directed by Managing Director/HSRDC.

31A. *It has been in principle decided that HSRDC would supply receipt books free of cost to the entrepreneurs for use at toll point. The receipt book (S) other than issued by HSRDC would not be used by entrepreneur at the toll point. The entrepreneur would only be permitted to arrange receipt books at his level when there is interruption in supply of receipt books because of failure at the level of source engaged by HSRDC for supply of receipt books or some other unavoidable reasons and no claim would be entertained from the entrepreneur for making such arrangement at his level.*

The entrepreneur/agent will give receipt machine numbered (to be supplied free of cost by HSRDC) to respective payee for the amount of toll received as per specimen given in Section-10 Form No. 1. The receipt book should carry receipts in triplicate, each in different colour. One copy for payee, another for entrepreneur and third for submitting to HSRDC by the entrepreneur at the end of each month. The back of receipt would bear the toll rates applicable as per Govt. notification. The entrepreneur will issue receipts after recording all details given in Form No. 1. The complete registration No. (not only numerical numbers) with type of vehicle should be mentioned on all the three copies while issuing receipt to the payee.

32. If the Entrepreneur/Agent is imprisoned, becomes insolvent, compound with his creditors has a receiving order made against him or carry on being under a receiving for the benefit of the creditors or any of them or being partnership firm become dissolved, or being a corporation goes into liquidation or wind up for the purpose of amalgamation or reconstruction. The department shall be at liberty :-
- i) To give such liquidator, receiver, or other person in whom the contract may be vested the option of carrying out the contract or a portion thereof to be determined by the department, subject to his providing the appropriate guarantee for the performance of such contract or
 - ii) To terminate the contract forthwith by notice in writing to the Entrepreneur/Agent, the liquidator, the receiver or person in whom the contract is vested, this termination is ordered under the agreement.
 - iii) The Entrepreneur/Agent will make compliance of any statutory requirement to keep record to pay the dues of taxes duties custom etc. as per law to respective authorities.
33. The Entrepreneur/Agent shall confirm & abide by all the laws of the land and the regulations and bye laws of local authorities, and of any water or electricity companies with whose systems the structure is proposed to be connected. The Entrepreneur/Agent shall give all notice required by the said Acts, regulations or bye-laws and pay all fees in connection therewith. He shall also ensure that no attachments are made against property. The Entrepreneur/Agent shall protect and save HSRDC against all claims or liabilities arising from or based on the violation of such laws, ordinance, bye-laws, decree or attachment by him or by his employees.

34. CHANGE OF CONSTITUTION:- Where the Entrepreneur/Agent is a partnership firm, the prior approval in writing of the Managing Director, HSRDC shall be obtained before any change is made in the constitution of the firm, where the Entrepreneur/Agent is an individual or a Hindu undivided business concern such approval as aforesaid shall likewise be obtained before the Entrepreneur/Agent enters into any partnership agreement where under the partnership firm would have the right to carry out the work hereby undertaken by the Entrepreneur/Agent. If prior approval as aforesaid is not obtained, the contract shall be deemed to have been assigned in contravention of terms of agreement and the action will be taken for termination of contract and same consequences shall be applicable.

35. LABOUR LAWS:-The Entrepreneur/Agent shall comply with all the provisions of minimum wages Act 1948, workman's compensation Act 1923, contract labour Regulation and abolition Act 1970 and the rules framed there under, the payment of wages Act 1936, Employees liability Act 1938. Maternity benefits Act 1961. The apprentices Act 1961 and rules framed there under and the Industrial Disputes Act, 1947. He shall also make satisfactory arrangement for the workmen employed on the work.

In every case in which by virtue of provisions of the contract regulation and Abolition Act 1970. and of the contract labour Rules, HSRDC is obliged to pay any amount of wages to a workmen employed by the contract in execution of the works or to incur any expenditure in providing welfare and health amenities required to be provided under the above said act and the rule under the P.W.D. Entrepreneur/Agent's labour regulations or under the rules framed by the Government from, time to time, for the protection of health and sanitary arrangement for workers employed by Entrepreneur/Agent, the Government will recover from the Entrepreneur/Agent, the amount of wages so paid or the expenditure so incurred without prejudice to the rights of the HSRDC under section 20 Sub-Section (1) and section 21 Sub- Section (4) of the contract Labour (Regulation and Abolition) Act 1970. Managing Director, HSRDC shall be at liberty to recover such amount or any part thereof by deducting it from the security deposit or from any sum due by Managing Director, HSRDC to the Entrepreneur/Agent whether under this contract or otherwise. Managing Director, HSRDC shall not be bound to contest any claim made against it under section 20 Sub section (1) and section 21. sub section (4) of the said Act except on the written request of the Entrepreneur/Agent and upon his giving to the HSRDC full security for all cost for which the HSRDC might become liable in contesting such claim.

36. ENTREPRENEUR/AGENT LIABLE FOR PAYMENT OF COMPENSATION TO INJURED WORKMAN OR IN CASE OF DEATH.

In every case in which by virtue of the provision of the section 12, Sub-section (1) of the workman's compensation Act.1922, the HSRDC is obliged to pay compensation to a workman employed by the Entrepreneur/Agent in the performance of the contract, the HSRDC will recover from the Entrepreneur/Agent the amount of compensation so paid without prejudice to the right of HSRDC under section 12, sub section (ii) of the said Act. The HSRDC shall be at liberty to recover such amount or any part thereof by deducting it from the security deposit or from any sums due by the HSRDC to the Entrepreneur/Agent whether under this contract or otherwise HSRDC shall not be bound to contest any claim made against it-under section 12, Sub-section (1) of the said Act except on the written request of the Entrepreneur/Agent and upon his giving to HSRDC full security for all costs for which the HSRDC might become liable in consequence of contesting such claim.

37. The Fee Inspectors will be posted with necessary guard to assist at either end of the Tolling point who shall be authorized to collect fee in respect of any mechanical vehicle crossing the toll point at the rate specified in the schedule. There shall be provided, at either of the end of a toll point, a cross bar for securing the stoppage of mechanical vehicle. The fee inspector shall ensure at the cross bar that passages is not allowed to mechanical vehicle unless the fee leviable in respect there of has been paid.

38. Except where otherwise provided or specified in this agreement and subject also to such powers as **may be delegated by the Managing Director, HSRDC to the Executive Engineer (PWD B&R) concerned or anyone else for the time being in charge of the said fee collection**, on all questions and matter whatsoever arising out of or in relation to or in connection with this Agreement or as to the interpretation of any of its conditions whether during the currency of this Agreement or at any time thereafter, shall be final and binding on the Entrepreneur/Agent.

Provided that, in the event that the Entrepreneur/Agent disagrees with any decision of the Executive Engineer concerned or person authorized by Managing Director, he may send a written communication to the Executive Engineer concerned or person authorized by Managing Director indicating the issues.

39. In the event the Entrepreneur/Agent disagreeing, with the decision mentioned in the provision of above, he may request the Managing Director, HSRDC, for appointment of an Arbitrator for adjudication of the dispute. On receipt of request from the Entrepreneur/Agent for appointment of Arbitrator, Managing Director,

HSRDC will appoint an Arbitrator for adjudication of the dispute. The arbitrator so appointed shall conduct the arbitration proceedings in accordance with the provision of the contract agreement. Fee of the Arbitrator shall be paid by the party who will seek the arbitration.

- 40. Pending appointment of Arbitrator or resolution of the dispute by Arbitrator, the Entrepreneur/Agent will continue to remit the agreed installment of money to the Managing Director, HSRDC.
- 41. The Entrepreneur/Agent shall bear and pay the stamp duty in respect of this agreement as per Stamp Act 1899.
- 42. Upon the expiry of the period of this agreement or earlier termination of contract all rights of the Entrepreneur/Agent in the fee collection gates shall stand transferred to the Managing Director, HSRDC concerned without any cost being payable to the Entrepreneur/Agent, by the Managing Director, HSRDC.
- 43. The Entrepreneur/Agent shall also perform the duties and functions as appended here in after under this head.
- 44. **AMENDMENT:**

Terms of this Contract can be amended with the mutual consent of both the parties.

In witness thereof the parties hereto set their respective hands and seals on the _____ day of _____ Month and year _____ in the presence of

Signature of Dy. General Manager, with seal

Name:-
 Designation:- Dy. General Manager
 for Managing Director
 Haryana State Roads & Bridges
 Development Corporation Limited

Signature of Entrepreneur / Agent with seal

Name of Entrepreneur/Agent:-
 Address of Entrepreneur/Agent:-
 Signed, sealed & delivered by Sh.-----
 in the capacity of Entrepreneur.

Signature, Name & Address of witnesses

- 1. _____
- 2. _____

Signature, Name & Address of witnesses

- 1. _____
- 2. _____

SECTION-7

SCHEDULE OF TOLL RATES

| Sr. No. | Particulars of vehicles | Toll Rates 1.04.2012 |
|---------|--|--|
| 1. | Trucks (laden with goods or unladen) Canters/multi axle vehicles/dozers and earth movers etc. | Rs.200/- per trip including return journey |
| 2. | Buses/mini buses with Stage Carriage Permits | (i)Rs.200/- per trip, for single trip including return journey. (ii)Rs.300/- for daily pass. (iii)Rs.6000/- for monthly pass |
| 3. | Buses/mini buses with Contract Carriage Permits | Rs. 200/- per trip including return journey |
| 4. | Maxi cabs | Rs.20/- per trip including return journey |
| 5. | Light Commercial Goods Vehicles like Mahindra and Tata Pick Up Vans/loaded tractor trolley carrying non-agriculture products | Rs.50/- per trip including return journey |
| 6. | Vehicles having more than 10 tyres | Rs. 300/- per trip including return journey |

The following vehicles are exempted from the payment of toll over this toll facility :-

- i) Defence vehicles.
- ii) Non Commercial Vehicles of all state Governments and Government of India.
- iii) Police vehicles
- iv) Fire Fighting vehicles.
- iv) Ambulances.
- v) Funeral vans.

NOTE 1.: *The above toll rates include single return trip on the same day through the same toll point. When the same vehicle has to cross this toll point more than once in the same direction on the same day, then the user shall have to pay toll again for the additional trip at the same toll rates except for the vehicles having daily and monthly passes. However, if the user also crosses any other toll point of any other toll facility on the same day, the user will have to pay toll at that toll point also as applicable.*

NOTE 2.: *No toll is levied on two wheelers, jeeps other than maxi cabs, cars, tractors & tractors with trolley for agricultural purposes.*

SECTION- 8

FUNCTIONS & DUTIES TO BE PERFORMED BY THE ENTREPRENEUR / AGENT

Schedule-1

1. To demand and collection of toll only from motor vehicles and trailers driven by such vehicle that pass over the toll point at the rates mentioned in the schedule.
2. To construct, maintain and use the toll station only for the purpose of collection of toll and for no other purpose what so ever and to protect it.
3. To pay to HSRDC cost of making good the damage caused to the said road / toll station.
4. To make the necessary arrangements for lighting to ensure proper working of the toll station and regulations of traffic near it by way to:-
 - (a) Maintain the existing electric arrangement and electric lighting and arrange petromax lamp etc. in sufficient number including all expenses required thereof for the entire period of the agreement.
 - (b) Paying punctually the electricity charges payable in respect of consumption of electricity at all toll station. if and wherever such electric lighting arrangement are already provided by Government as they become due and payable and not to allow them to fall in arrears for the entire period of agreement.
5. To replace bulbs and tubes in the toll station.
6. To permit the officers duly authorized in that behalf at any time or at times during the currency of this agreement to enter upon the premises of the toll station for the purpose of inspection.
7. To permit officers of HSRDC of the rank of J.E. and above to enter the toll collection premises for the purpose of inspection and checking from time to time.
8. To carry out and observe the directions that may from time to time be given to him by the Executive Engineer or representative of Managing Director.
9. The Entrepreneur /Agent has to make his own arrangement for the residence of his staff working on toll station. No accommodation will be made available and neither toll plaza nor office building will be utilized as a residence or rest room.
10. The Entrepreneur/Agent should make all his own arrangement for water supply for drinking as well as for other utilization at his cost.
11. The Entrepreneurs/Agent will have to get insured all his staff working on toll station against accident etc.

- 12. The Entrepreneurs/Agent shall maintain the fee collection gates and other works connected therewith in good repair during the execution of this agreement.
- 13. All the persons employed by the Entrepreneur/Agent while on duty at the fee collection gates shall wear neat uniforms with same badges indicating names.
- 14. The Entrepreneurs/Agent shall report at once to the officers in charge of the nearest police station of any accident occurring on or near the toll point by which the death or serious injury is caused.
- 15. The Entrepreneur/Agent shall see that vehicle carrying Government mails are not unreasonably delayed in crossing the Toll point .
- 16. The Entrepreneurs/Agent shall not employ in connection with collection of toll, any person who hasn't completed 18 years of age. Any person having infectious disease lunatic, convict of criminal offence, declared misconduct shall not be employed.
- 17. The entrepreneur/agency should install appropriate hoardings/reflective Boards relating to 'User fee,' exempted category, placards etc. as depicted in the enclosed '**Layout Plan**' and details given in **Annexure-2**.

In witness thereof the parties hereto set their respective hands and seals on the _____ day of _____ Month and year _____ in the presence of

| | |
|--|---|
| Name & address. _____ 1. _____ 2. _____ In the presence of Name & address. | Signature of Entrepreneur/Agent Signed sealed & delivered by capacity of Entrepreneur |
|--|---|

SECTION- 9

Schedule-2

Details of the registers to be maintained by the agent at fee collection gates.

Registers to be maintained by the Agency

- (i) Register showing the daily collection of toll fee of different toll rates on different booths.
- (ii) Register showing the amount of fee collected every day in a particular month.
- (iii) Statement showing the details of fee collected and expenditure incurred by agency, on monthly basis.
- (iv) Report of inspection.

After the expiry of the franchisee period, all the above documents and registers should be handed over to the Executive Engineer.

Schedule-3

Controls and checks to be exercised by Department

Correctness of the fee charges recovered from users with date as prescribed.

Issue of proper receipt to all vehicles.

Maintenance of proper registers.

Monthly remittance of tolls collected by the agent by the prescribed date.

Toll plaza and its appurtenances are being maintained by the agent at his cost and are in good running condition.

Arrangements for lighting and water are in order.

There is no inordinate delay to the traffic due to procedure of collection of fees; there is no traffic jam at fee collection gates.

SECTION-10

FORM No. 1

I. (On front side)

Book No.

Receipt No.

Specimen form of receipt to be issued for collection of toll

Receipt for payment of toll fee

Toll Facility *(as given in section-3, Clause-8)*

Location of Toll Point _____

Date UP

Time Down

1. Description of vehicle with Registration number
2. Amount of fee paid
(including return journey)

Signature of fee Inspector
(Seal of Agent)

II. On back side

List of toll rates as applicable vide gazette notification of applicable date

Form No. 2

Report of inspection of an Authorized Officer

Sr. No.

Name of Inspection Officer

Date & Time of Inspection

Results (Inspection)

Signature of inspecting officer

Remarks

(1)

(2)

(3)

(4)

(5)

(6)

Form No. 3

Register showing the checking of fee collection gates

Sr. No.

Designation of Officer

Date

Time

(1)

(2)

(3)

(4)

(5)

SECTION-11

BID SECURITY (BANK GUARANTEE)

WHEREAS, _____ [name of Bidder] (hereinafter called "the Bidder") has submitted his Bid dated _____ [date] for the collection of Toll fee at toll point at **toll point on (as given in section-3, Clause-8) for a period** _____ (hereinafter called "the Bid").

KNOW ALL PEOPLE by these presents that We _____ [*name of bank*] of _____ [*name of country*] having our registered office at _____ (hereinafter called "the Bank") are bound unto **Managing Director, Haryana State Roads & Bridges Development Corporation Limited.** (hereinafter called "the Employer") in the sum of _____¹ for which payment well and truly to be made to the said Employer the Bank binds itself, his successors and assigns by these presents.

SEALED with the Common Seal of the said Bank this _____ day of _____ 20_____.

The bid security shall be forfeited and the conditions of this obligation are:

- (a) If the bidder withdraws or modifies his bid/offer after the last date and time for the receipt of bids during the period of bid validity (180 days) or extended validity period ; or
- (b) In the case of successful bidder, fails within the specified period of 21 days to:-
 - i) Furnish the required security deposit and deposit first installment in advance alongwith T.C.S. @ 2% or as applicable from time to time; and
 - ii) Sign the Agreement

we undertake to pay to the Employer up to the above amount upon receipt of his first written demand, without the Employer having to substantiate his demand, provided that in his demand the Employer will note that the amount claimed by him is due to him owing to the occurrence of one or any of the three conditions, specifying the occurred condition or conditions.

This Guarantee will remain in force up to and including the date _____ i.e. 180 days after the dead line for submission of bids as such deadline is stated in the Instructions to Bidders or as the Employer may extend it, notice of which extension(s) to the Bank is hereby waived. Any demand in respect of this guarantee should reach the Bank not later than one month grace period beyond the above date i.e. _____.

DATE _____ SIGNATURE OF THE BANK _____

WITNESS _____ SEAL _____

[signature, name, designation, address and Code No. of signing Officer]

[Name of Controlling Office and Officer and officer telephone No.]

Note: The Branch issuing Bank Guarantee should be CBS Branch.

SECTION-12

SECURITY DEPOSIT (FORM OF BANK GUARANTEE)

To: **Managing Director**, _____ *[name of Employer]*
Haryana State Roads & Bridges Development Corporation Limited, Bays No. 13-14,
Sector-2, Panchkula_ *[address of Employer]*

WHEREAS _____ *[name and address of Entrepreneur/Agent]*
 (hereinafter called "the *Entrepreneur/Agent* ") has undertaken, in pursuance of Contract
 No. HSRDC/ _____ dated _____ to execute the work of **collection of toll fee at toll**
point on (as given in section-3, Clause-8) for a period _____ *[name of Contract*
and brief description of Works] (hereinafter called "the Contract");

AND WHEREAS it has been stipulated by you in the said Contract that the Contractor shall
 furnish you with a Bank Guarantee as per guidelines approved by Board of Directors
 (**Annexure-I**) by a recognized bank for the sum specified therein as security for compliance with
 his obligations in accordance with the Contract;

AND WHEREAS we have agreed to give the Contractor such a Bank Guarantee;

NOW THEREFORE we hereby affirm that we are the Guarantor and responsible to you, on
 behalf of the Contractor, up to a total of _____ *[amount of guarantee]*
 i _____ *[in words]*, such sum being payable in the types and
 proportions of currencies in which the Contract Price is payable, and we undertake to pay you,
 upon your first written demand and without cavil or argument, any sum or sums within the limits
 of _____ *[amount of guarantee]*¹ as aforesaid without your needing to prove or
 to show grounds or reasons for your demand for the sum specified therein.

We hereby waive the necessity of your demanding the said debt from the Contractor before
 presenting us with the demand.

We further agree that no change or addition to or other modification of the terms of the Contract
 or of the Works to be performed there under or of any of the Contract documents which may be
 made between you and the Contractor shall in any way release us from any liability under this
 guarantee, and we hereby waive notice of any such change, addition or modification.

This guarantee shall be valid for a period upto 90 days of the expiry of the Contract period/tolling period i.e. upto _____.

Signature and seal of the guarantor _____

Name of Bank _____

Address _____

Date _____

[signature, name, designation, address and Code No. of signing Officer]

[Name of Controlling Office and Officer and officer telephone No.]

Note: The Branch issuing Bank Guarantee should be CBS Branch.

Annexure-I**Guidelines for Bank Guarantees****Permitted Banks**

1. Bank Guarantees issued by Banks covered under the following categories should only be accepted under the contracts:-
 - a. State Bank of India or its subsidiaries.
 - b. Any Indian Nationalized Bank.
 - c. IDBI or ICICI/ICICI Bank/Export Import Bank/AXIS/HDFC/Yes/Haryana State Cooperative Banks.
 - d. A Foreign Bank (issued by a branch outside India) with a counter guarantee from SBI or its subsidiaries or any Indian Nationalized Bank.
 - e. Any Scheduled Commercial Bank approved by RBI having a net worth of not less than Rs. 200 crores as per the latest Annual Report of the Bank. In the case of a Foreign Bank, the net worth in respect of the Indian operations shall only be taken into account.
 - f. All Bank Guarantees/FDRs should be from CBS branches (online branches) so that these can be verified online at any station from any branch of that Bank. In case of HARCO Bank, the requirement of CBS Branch is not required.
2. The acceptance of the guarantee shall also be subject to the following conditions:-
 - a. The Bank Guarantee issued by a Cooperative Bank shall not be accepted.
 - b. The Bank Guarantee issued by a Bank specifically debarred/black listed for non-cooperation in the past in respect of verification of BG or any other reason. The Bank for non-cooperation will be identified and action as approved by Govt. shall be implemented by the Deptt.

Format of Bank Guarantees

3. The Bank Guarantee(s) to be submitted by the contractors and consultants against performance security/advance payments and for various other purposes shall be as per the prescribed formats. It shall be ensured that
 - a. The Bank Guarantee(s) contains the name, designation, code number of Officer(s) signing the guarantee(s),
 - b. The covering letter of the Bank Guarantee from the Bank contains the address and other details (including telephone No.) of the controlling officer of the Branch of the Bank issuing the Bank Guarantee. [Please see that Controlling Offices of the Banks are at regional level and hence each Bank has very few controlling offices.

Annexure-2

Legend:

H = Hindi

UF = User fee

E = English

EC = Exempted category

SL = Speed Limit

| Sr. No. | Code | Type of board | Language | Text | Size of display board | Location of the board from the point where area of the user fee collection area starts unless otherwise specified | Height above the ground level | Font size | Angle with Toll Road |
|---------|--------|--|----------|---|-----------------------|---|-------------------------------|--------------|----------------------|
| 1 | 2 | 3 | 4 | 5 | 6 | 7 | 8 | 9 | 10 |
| 1 | SL | Grounded in shoulder | E. | 50 Kmph. | 0.6 m dia | 350 m | 1.6 m | 12 cm height | 85 degree |
| 2 | UF-(E) | -Do- | E | As per details given in gazetted notification dated as applicable | 7.5 m x 3.1 m | 190 m | 1.6 m | 15 cm height | 85 degree |
| 3 | EC-(E) | -Do- | E | -Do- | 3.1 m x 3.1 m | 190 m | 1.6 m | 15 cm height | 85 degree |
| 4 | UF-(H) | -Do- | H | Translate text as given in Sr. No. 2 col.5 below into Hindi | 7.5 m x 3.1 m | 300 m | 1.6 m | 15 cm height | 85 degree |
| 5 | EC-(H) | -Do- | H | Translate text as given in Sr. No. 3 col.5 below into Hindi | 3.1 m x 3.1 m | 300 m | 1.6 m | 15 cm height | 85 degree |
| 6 | UF | Placard displayed on approaching side face of the booth wall | H | Translate text as given in Sr. No. 2 col.5 above into Hindi | 1.5m x 0.85 m | Placard displayed on approaching side face of the booth wall | 0.3 m | 3 cm | - |
| 7 | UF | Placard displayed over the fee collection window | H | Translate text as given in Sr. No. 2 col.5 below into Hindi | 1.1m x 0.45 m | Placard displayed over the fee collection window | - | 2 cm | - |

LAYOUT PLAN

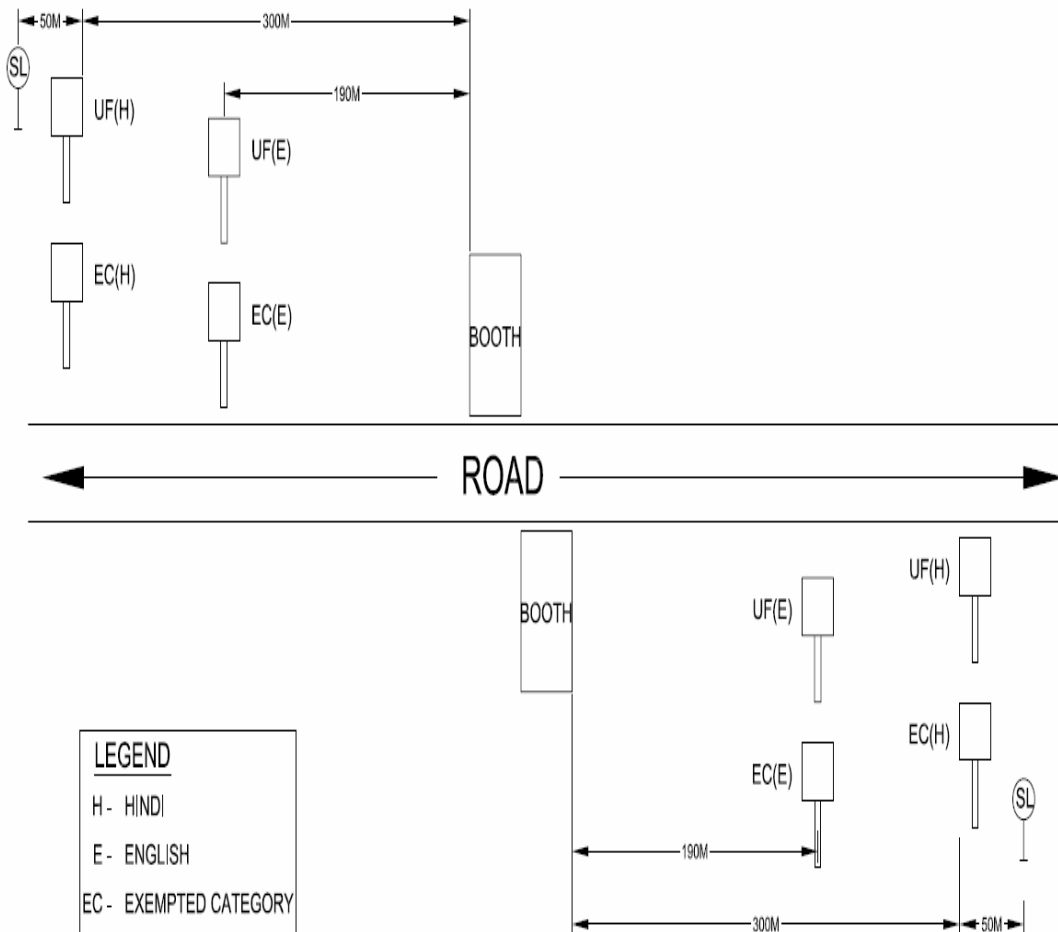

| LEGEND | |
|--------|-------------------|
| H - | HINDI |
| E - | ENGLISH |
| EC - | EXEMPTED CATEGORY |
| UF - | USER FEE |
| SL - | SPEED LIMIT |