

Trans-Cal Industries, Inc.

Model SSD120-(XX)N-RS5
&
Model SSD120-(XX)NE-RS5
(Includes Mod. 1 Data)

All Solid-State
Altitude Encoder/Digitizer

Owner/Installation Manual

FAA TSO-C88a Approved
EASA ETSO-C88a Approved

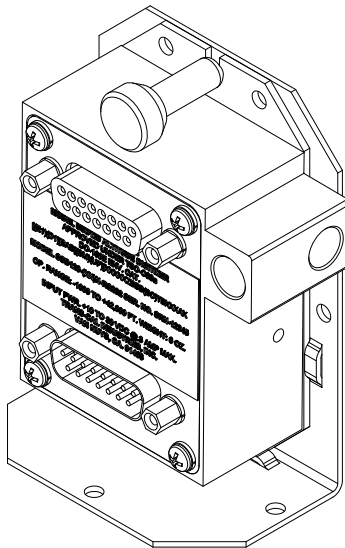

Trans-Cal Industries, Inc.
Van Nuys Airport
16141 Cohasset Street
Van Nuys, CA 91406-2908
(818) 787-1221 (800) 423-2913 fax (818) 787-8916
www.trans-cal.com

Copyright

This document may not be reproduced, transmitted, or copied in any form without the prior written consent of Trans-Cal Industries, Inc. The data contained herein is subject to change without notice. Trans-Cal Industries hereby grants permission to download one copy of this manual and any subsequent revision, provided that electronic or printed copy contains this complete copyright notice. Trans-Cal Industries explicitly prohibits any unauthorized commercial distribution of this manual or any revision thereto.

Limitations Please Note:

It is the responsibility of the installer of this equipment, within a specified type or class of aircraft, to determine that the aircraft operating conditions are within TSO or ETSO standards. DO-160E lightning induced transient susceptibility tests were not conducted on this device and it is the responsibility of the installing agency to substantiate compliance with FAR25.1316. Advisory Circular AC20-136A provides guidance related to the protection of aircraft electrical systems from the effects of lightning.

© 2012 by Trans-Cal Industries, Inc.
16141 Cohasset Street
Van Nuys, CA 91406
818/787-1221
800/423-2913 x400 Tech Support
FAX 818/787-8916
E-Mail: support@trans-cal.com
www.trans-cal.com

What's in the Box:

Qty.	Part Number	Description
1 ea.	SSD120-(XX)N-RS5	Altitude Digitizer with five RS232 Outputs
1 ea.	882204	Owner/Installation Manual
1 ea.	DA-15S	15 Pin D-Subminiature Mating Connector - Receptacle
2 ea.	600016	15 Pin Connector Back Shell
1 ea.	DA-15P	15 Pin D-Subminiature Mating Connector - Plug
1 ea.	600019	1/8-27 NPT Nylon tube fitting
1 ea.	600020	1/4" Tube Polypropylene tee fitting
1 ea.	103024	1/8-27NPT Nylon Plug

History of Revision

Revision	Date	Description
A	3/2009	Production release.
B	2/2010	Corrected §6.5.
C	6/2012	Updated copyright data, added KXP 755 data, corrected Century Fight Systems pin data, and ECP calibration data.

Table of Contents

Abbreviations, Acronyms and Symbols	5
Section 1.0 Introduction	6
1.1 Scope	6
1.2 Equipment Description	6
1.3 General Specifications	6
1.3.1 Operating Altitude	6
1.3.2 Accuracy	7
1.3.3 Mechanical Characteristics	7
1.3.4 Environmental	7
1.3.5 Over Range	7
1.4 Parallel ICAO Altitude Data Port Specifications	7
1.5 Serial Altitude Data Port Specifications	7
1.6 Serial Port Altitude Data Resolution	8
1.7 Serial Communication Format	8
1.8 Serial Communication Protocol	8
1.8.1 UPS Aviation Technologies/Garmin AT/IIMorrow Nav. Devices	8
1.8.2 Trimble Garmin Navigation Devices Protocol	8
1.8.3 Northstar Navigation Devices Protocol	9
1.8.4 Magellan Navigation Devices Protocol	9
1.8.5 ARNAV Systems Protocol	9
1.8.6 UPS AT 618 Loran Devices Protocol (IIMorrow)	9
1.8.7 One-Foot Resolution Protocol	10
Section 2.0 Operation	11
2.1 General	11
2.2 Operating Instructions	11
Section 3.0 Installation	12
3.1 Mechanical Installation	12
3.2 Electrical Installation	12
3.3 Serial Altitude Data Port Test Equipment	13
3.4 Parallel ICAO Altitude Data Port Test Equipment	13
Section 4.0 Calibration and Configuration	14
4.1 Calibration Overview	14
4.2 Required Equipment Span Adjust	15
4.3 Required Equipment Dynamic Calibration	15
4.4 Span Adjust Procedure	15
Figure 1 Altitude Digitizer Correspondence	17
4.5 Dynamic Calibration Adjustment Procedure using the ECP-100	18
Figure 2 Dynamic Calibration Set-Up Using the ECP-100	19
4.6 Hyper Terminal Set-Up on the IBM Compatible PC	20
4.7 Serial Port Software Configuration	21
4.8 Serial Port One-Foot Resolution Configuration	22
4.9 Dynamic Calibration Adjustment Procedure	23
4.10 Serial Port Software Configuration Using the ECP-100	25
Figure 3 Serial Port Configuration Using the ECP-100	26
4.11 Configuration and Calibration Command List	27
4.12 Error Correction Table	28
Section 5.0 Tables I through X Digitizer Interconnection	29
Table I Bendix/King	29
Bendix/King (Honeywell) KT 73 Transponder with Serial Altitude Data Input	30
Table II Cessna, Narco, Microair	31
Table III Garmin	32
Table IV Garmin	33
Table V Edo-Air, Genave, Collins, Radair	34
Table VI Bendix, Wicox, UPS AT	35
Table VII Becker, Terra, Trig	36
Table VIII Honeywell	37

Tables IX and X Serial Data Connector and Protocol Selection.....	38
Section 6.0 GPS/MFD & Miscellaneous Connection Data	39
6.1 UPS Aviation Technologies (IIMorrow).....	39
6.2 Trimble	40
6.3 Garmin International	41
6.4 ARNAV Systems, Inc.....	42
6.5 Century Flight Systems.....	43
Section 7.0 Instructions for Continued Airworthiness	44
Section 8.0 Adapter Plate Ordering Information	44
Section 9.0 Frequently Asked Questions.....	45
Section 10.0 Known Compatibility Issues.....	48
10.1 Honeywell KT 73 Transponder with Serial Altitude Data Input.....	48
10.2 Narco AT5A, AT6A, AT-50 and AT-50A Installations and SSD120-(XX)N Mod.1	48
10.3 "Mod. 1" Installations.....	48
10.4 King KT-75.....	48
10.5 S-Tec (Collins) TDR950.....	48
10.6 Trans-Cal SSD120-(XX)N Backwards Compatibility	48
10.7 SSD120-(XX)N-RS5 Compatibility to Competitor's Products	49
Wiring Harness Diagram Part Number 881404	50
Span Adjust Block Diagram	51
Dynamic Calibration Block Diagram	52
Figure 2 Temperature vs. Warm-up Time.....	53
Outline Drawing	54
Environmental Qualification Form.....	55
Part Number Builder	56
Manufacturer Direct Warranty.....	57

Abbreviations, Acronyms and Symbols

A	Amperes
AC	Advisory Circular
ARINC	Aeronautical Radio Incorporated
ASCII	American Standard for Coded Information Interchange
ATCRBS	Air Traffic Control Radar Beacon System
bps	Bits per second.
^C_R	Carriage Return
EASA	European Aviation Safety Agency
EEPROM	Electrically Erasable Read Only Memory
EIA	Electronic Industries Association
ETSO	European Technical Standard Order
FAA	Federal Aviation Administration
FAR	Federal Aviation Regulation
ft.	Distance in feet.
GPS	Global Positioning System
Hz	Hertz
ICAO	International Civil Aviation Organization
I.F.F.	Identification Friend or Foe
In. Hg.	Inches of Mercury
Kbps	Kilobits per Second
KHz	Kilohertz
^L_F	Line Feed
LSB	Least Significant Bit
mA	Milliamperes
max.	Maximum
MB	Millibar
MHz	Megahertz
MFD	Multi-Function Display
MSL	Mean Sea Level
min.	Minimum
ms	Time in milliseconds.
MSB	Most Significant Bit
mW	Milliwatt
NIST	National Institute of Standards and Technology
oz	Ounce
psi	Pounds per Square Inch
RAM	Random Access Memory
RS	Recommended Standard
RTCA	RTCA Inc. (Radio Technical Commission for Aeronautics)
SAE	Society of Automotive Engineers
sec.	Time in seconds.
SSR	Secondary Surveillance Radar
TCI	Trans-Cal Industries, Inc.
TIA	Telecommunication Industries Association
TSO	Technical Standard Order
Vdc	Volts Direct Current
VSI	Vertical Speed Indicator
W	Watt
Ω	Electrical resistance measured in Ohms.
°C	Temperature in degrees centigrade.
±	Plus or minus.
§	Section

Section 1.0 Introduction

1.1 Scope

This manual provides detailed installation, calibration and operating instructions for Trans-Cal Industries' Model SSD120-(XX)N-RS5 and SSD120-(XX)NE-RS5¹ series of altitude encoder/digitizer.

1.2 Equipment Description

Approved under FAA TSO-C88a and EASA ETSO-C88a the Model SSD120-(XX)N-RS5 and SSD120-(XX)NE-RS5 is an all solid-state electronic device which, when connected to an aircraft's static and electrical system, converts pressure altitude information into parallel and serial digital data.

The parallel digital altitude data protocol is set forth in the ICAO International Standard for SSR Pressure Altitude Transmission. In accordance with U.S. National Standards for Common System Component Characteristics for the I.F.F. Mark X (SIF)/Air Traffic Control Radar Beacon System SIF/ATCRBS.

The serial altitude data is provided on (5) five asynchronous RS232 outputs which are divided into two groups. Group A consists of TxD1, TxD2 and TxD3. Group B consists of TxD4 and TxD5. The serial data protocol is selectable for each output group and may be used to provide pressure altitude data to transponders, GPS or other on board navigation devices. Refer to **Table IX, Table X** and **§4.6 & §4.7**.

1.3 General Specifications

This equipment has been tested and will utilize power in accordance with MIL-STD-704E for 28 Vdc systems.

Operating Voltage: Model SSD120-(XX)N-RS5 Model SSD120-(XX)NE-RS5 ²	+12 to 30 Vdc +12 to 30 Vdc
Operating Current all models:	0.26Amps at 14Vdc 0.28 Amps at 28Vdc
Operating Temperature: Model SSD120-(XX)N-RS5 Model SSD120-(XX)NE-RS5	-20° to +70°C (-4° to +158°F) -55° to +70°C (-67° to +158°F)
Storage Temperature (non-operating) all models:	-65° to +85°C (-85° to +185°F)
Warm-up time:	0 Seconds at +20°C (+68°F) and higher. See Figure 2 for low temp warm-up times.
Weight:	5.1 oz. (6 oz. with tray)

1.3.1 Operating Altitude

Model	Operating Altitude
SSD120-30N()-RS5	-1000 to +30,000 feet.
SSD120-35N()-RS5	-1000 to +35,000 feet.
SSD120-42N()-RS5	-1000 to +42,000 feet.

¹ SSD120-(XX)NE-RS5 Extended operating temperature range: -55° to +70°C. Operate low temperature (-55 C) at +28Vdc.

² Longer warm-up times will be experienced when operated at +12 Vdc.

1.3.2 Accuracy

Digitizer accuracy is ± 50 feet from -1000 to +30,000 feet, and ± 75 feet from 30,100 to +42,000 feet, when measured from the altitude transition points of the ICAO code and referenced to 29.92 In. Hg. (1013 MB.) See **Figure 1** and **§4.0**.

1.3.3 Mechanical Characteristics

Model Number	Dimensions	Weight
Model SSD120-30N()-RS5	<i>See Outline Drawing</i>	5.1 oz.
Model SSD120-35N()-RS5	<i>See Outline Drawing</i>	5.1 oz.
Model SSD120-42N()-RS5	<i>See Outline Drawing</i>	5.1 oz.

Mounting tray adds 1 oz. To the weights listed above

1.3.4 Environmental

All model SSD120-(XX)N()-RS5 digitizers have been designed and tested to meet the requirements of TSO-C88a and ETSO-C88a, This device is tested in accordance with RTCA Document DO160E, dated December 2004 Environmental Category: D1BAB[(SM)(UF)]XXXXXXZBBB(BC)TTBXXXAX. See Environmental Qualification form for specific test information.

1.3.5 Over Range

The SSD120-(XX)N()-RS5 series of altitude digitizers will not be damaged when operated beyond their specified maximum altitude up to 100,000 feet MSL, (0.1581psi) or over pressured to -5721 feet (18psi) maximum.

1.4 Parallel ICAO Altitude Data Port Specifications

Code Format: In accordance with U.S. National Standard for Common System Component Characteristics for the IFF Mark X (SIF) Air Traffic Control Radar Beacon System, SIF/ATCRBS.

Driver Description: The parallel altitude data output is provided by the “uncommitted” collectors of a transistor array and must be “pulled-up” through a resistive load by the transponder.

Pull-Up Voltage: +3 to 40Vdc.

Maximum Sink Current: 50 mA.

Maximum Cable Length: 4000 ft. (1219 meters)

Input Signal Requirement: Pin 6 (strobe or signal common) must be either grounded or connected to the transponder.

1.5 Serial Altitude Data Port Specifications

Electrical Format: Conforming to the TIA/EIA RS-232C standard.

Logic Levels: “0”, +9 Vdc. Logic “1”, -9 Vdc.

Driver Output Maximum Voltage: ± 25 Vdc.

Driver Load Impedance: 3K Ω typ.

The RS232E standard recommends one receiver per serial port.

Maximum Cable Length: 50 Feet. (15.24 meters)

Code Format: ASCII

Communication System: Simplex

Transmission Method: Asynchronous. (Talk only.)

Baud Rate: Selectable, 1200 bps to 9600 bps.

Transmission Rate: 2/sec.

1.6 Serial Port Altitude Data Resolution

The default resolution of the altitude digitizer serial data is 100 feet. To enable 10-foot resolution, connect pin 2 of the DA-15S D-Subminiature connector to ground (see **Table VIII.**) The serial port resolution may also be configured via software, see **§4.6**. See **§4.7** for one-foot resolution.

1.7 Serial Communication Format

Model SSD120-(XX)N()-RS5 carries out serial communication asynchronously with the “Start/Stop” system. The specifics of the format, ie. the number of data bits, baud rate etc., is determined by the protocol selected. The default protocol is 1200bps, 8 data bits, 1 stop bit and no parity.

1.8 Serial Communication Protocol

Refer to **Table IX & X** and **§4.6 & §4.7 & §4.10**

Protocol is user selectable by grounding or leaving open pin 9 or pin 10 of the DA-15S serial data D-Subminiature receptacle, or by selecting protocols via software see **§4.6**.

1.8.1 UPS Aviation Technologies/Garmin AT/IIMorrow Nav. Devices.

Leaving pin 9 and 10 of the DA-15S serial data receptacle open results in a protocol compatible with UPS Aviation Technologies’ (IIMorrow) Navigation devices. The Digitizer will send a seventeen byte message beginning with # AL, then a space followed by five altitude bytes; the letter “T” and the sensor temperature, two checksum bytes and a carriage return. (1200bps, 8 data bits, 1 stop bit, no parity). The following is an example of the serial message for UPS AT (Garmin AT) (IIMorrow) devices.

Message	Definition
#AL +00800T+25D8 ^C _R	Pressure Altitude 800 feet

1.8.2 Trimble Garmin Navigation Devices Protocol

Grounding pin 10 of the DA-15S serial data receptacle results in a protocol compatible with some navigation devices manufactured by Trimble and Garmin. The Digitizer will send a ten-byte message. The message begins with ALT followed by a space and five altitude bytes; concluding with a carriage return. (9600bps, 8 data bits, 1 stop bit, no parity). The following are examples of serial messages for Trimble or Garmin devices:

Message	Definition
ALT -9900 ^C _R	Digitizer disabled.
ALT 10500 ^C _R	Pressure Altitude 10,500 feet

1.8.3 Northstar Navigation Devices Protocol

Grounding pin 9 of the DA-15S serial data receptacle results in a protocol compatible with some navigation devices manufactured by Northstar and Garmin. The Digitizer will send a 10-byte message. The message begins with ALT followed by a space and five altitude bytes; concluding with a carriage return. (2400bps, 8 data bits, 1 stop bit, no parity.) The following are examples of serial messages for these devices:

Message	Definition
ALT 02500 ^C _R	Pressure Altitude 2500 feet.
ALT -2500 ^C _R	Digitizer disabled.

1.8.4 Magellan Navigation Devices Protocol

Grounding both pins 9 and 10 of the DA-15S serial data receptacle results in a protocol compatible with some navigation devices manufactured by Magellan. The Digitizer sends a seventeen-byte message beginning with \$MGL, followed by a +/- sign and five altitude digits, then T+25, a checksum and concludes with a carriage return. (1200bps, 7 data bits, 1 stop bit, even parity.) The following is an example of a serial message for Magellan devices:

Message	Definition
\$MGL+02500T+25D6 ^C _R	Pressure Altitude 2500 feet.

1.8.5 ARNAV Systems Protocol

Leaving pins 9 and 10 of the DA-15S serial data receptacle open, the ARNAV Systems protocol *MUST* be software selected see §4.6 for protocol selection details. Once selected, the Digitizer will send a 24-byte message. Beginning with a \$PASHS followed by a comma and ALT, then a +/- sign followed by five altitude digits (in meters,) then an asterisk and a checksum followed by a carriage return and a line feed. (9600bps, 8 data bits, 1 stop bit, no parity.) The following is an example of an ARNAV serial altitude message:

Message	Definition
STX\$PASHS,ALT,+00033*1B ^C _R LETX	Pressure Altitude 33 meters.

1.8.6 UPS AT 618 Loran Devices Protocol (IIMorrow)

Leaving pins 9 and 10 of the DA-15S serial data receptacle open, the UPS AT 618 Loran devices protocol *MUST* be software selected see §4.6 for protocol selection details. Once selected, the Digitizer will send a seventeen byte message beginning with # AL, then a space followed by five altitude bytes; the letter "T" and the number "25"; two checksum bytes and a carriage return. (1200bps, 7 data bits, 1 stop bit, odd parity). The following is an example of an UPS AT 618 Loran serial altitude message:

Message	Definition
#AL +00800T+25D8 ^C _R	Pressure Altitude 800 feet

1.8.7 One-Foot Resolution Protocol

Leaving pins 9 and 10 of the DA-15S serial data receptacle open, the one-foot resolution protocol *MUST* be software selected see §4.8 for protocol selection details. Once selected, the Digitizer will send a seventeen byte message beginning with RMS, then a space followed by a sign, five altitude bytes; the letter "T" and the temperature sign; the number "55"; two checksum bytes and a carriage return. (9600bps, 8 data bits, 1 stop bit, no parity). The following is an example of the one-foot resolution altitude message:

Message	Definition
RMS +00859T+55C _R	Pressure Altitude 859 feet

This message is transmitted on TxD4 (pin 14) and TxD5 (Pin 15) ONLY!
The remaining serial ports TxD1 (pin 6), TxD2 (Pin 8) and TxD3 (pin 12) will transmit the protocol assigned via software or via the jumpers on the serial data receptacle DA-15S.

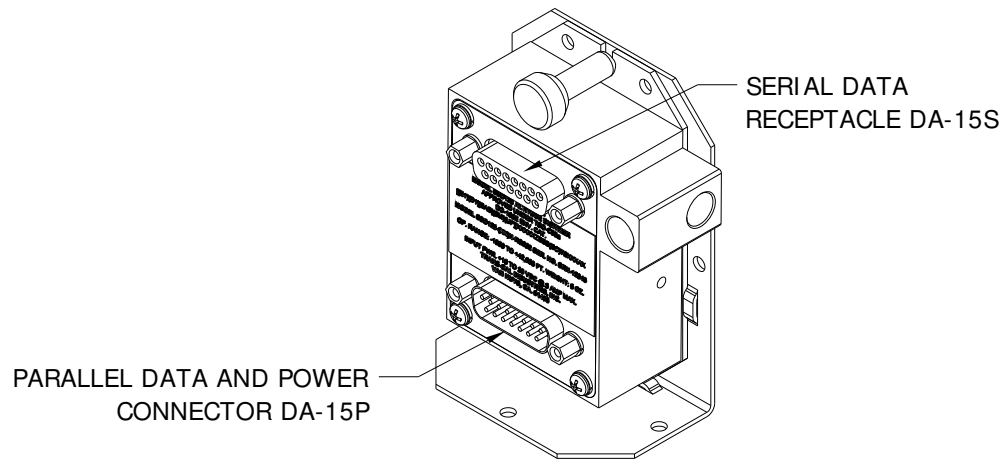

Section 2.0 Operation

2.1 General

The SSD-120(XX)N()-RS5 series of altitude digitizers are designed to be mounted within a pressurized or non-pressurized, but temperature controlled area within aircraft operating up to 42,000 feet MSL. Usually remotely located, the digitizer is fully automatic in operation. The parallel data output is controlled by the transponder while the serial altitude data is transmitted asynchronously. (Half duplex, talk only. Full duplex in calibration and configuration modes only.)

2.2 Operating Instructions

Parallel Data:

Place the transponder in mode "C", altitude-reporting mode, and apply power to the transponder and to the digitizer. In some installations the digitizer will automatically be supplied power when the transponder is energized; in others, power to the digitizer may be through a separate circuit breaker. If power to the digitizer is provided directly from the aircraft's avionics buss, follow the power-up procedures recommended by the transponder manufacturer. All parallel outputs will be pulled low for a self-test (3 seconds) at power up, then assume the value for the present input pressure. Note, a short the warm-up time may affect the actual data enable time. At 0°C a 30 second period is required before the data will enable. In some installations, the transponder controls the digitizer by enabling and disabling its output. In other installations, the digitizer's output is not controlled by the transponder and is continuously enabled, (Digitizer pin 6 is grounded.)

Serial Data

The serial communication is fully automatic and transmission begins after the self-test is complete. Strobing (pin 6) the parallel ICAO altitude data output of the digitizer will not affect the serial data transmission.

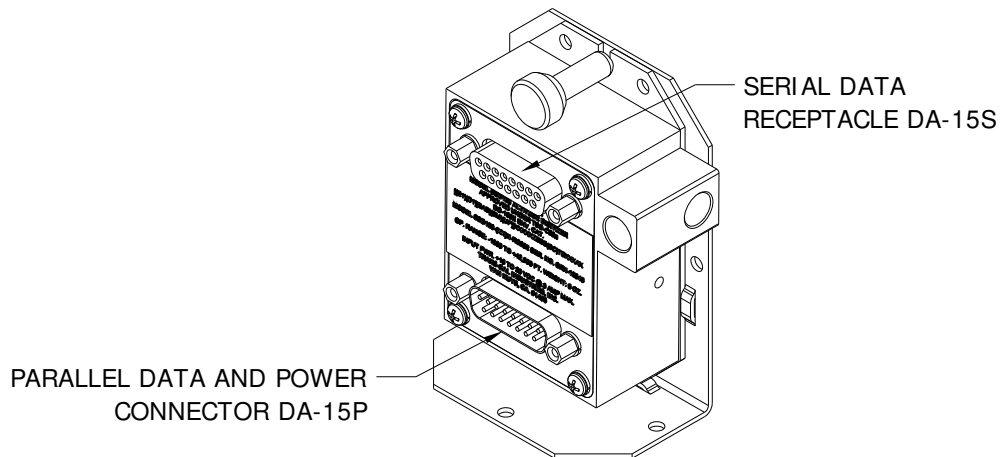

Section 3.0 Installation

3.1 Mechanical Installation

The SSD120-(XX)N()-RS5 series of digitizer may be mounted in any attitude within the internal structure of the aircraft. DO NOT mount the digitizer in the direct air stream of either hot or cold air ducts. The mounting position should allow for a short static pressure line from the digitizer to the altimeter, access to the digitizer's adjustments, and ample room for a service loop for the interconnecting cabling to the transponder. The SSD120-(XX)N-RS5 is provided with two static port inlets, either or both may be used to connect the digitizer to the aircraft static system. If only one static port inlet is used, install the 1/8-27NPT plug included with the connector kit into the unused static port. Apply pipe sealant (not included) or equal to the plug. Exercise care to prevent excess sealant from plugging the inlet to the pressure sensor.

On SSD120-(XX)NE-RS5 devices operating below -20°C, use metal fittings on all static line connections. The coefficient of thermal expansion for nylon is roughly three times that of aluminum. Nylon and plastic fittings will leak at low temperatures due to thermal contraction. Use an appropriate anti-seize compound when mating metal fittings to the encoder.

To prevent the accumulation of condensation in the digitizer, locate this device away from the lowest section of the static system, and ensure a proper condensation trap and system drain is installed and functional.

Use #4-40 or #6-32 machine screws, sheet metal screws, or pop rivets to attach the digitizer or the mounting tray to the airframe. Secure mating connectors to the digitizer housing using the #4-40 screws provided. Refer to the outline drawing for mechanical dimensions.

Adapter plates are available to convert older Trans-Cal and competing digitizer installations for use with the SSD120-(XX)N(X)-(X) series of altitude digitizers. See ordering information in **§8.0**.

3.2 Electrical Installation

Please note, proper solder or crimp techniques should be observed when attaching wires to the mating connectors. Failure to do so could result in damage, intermittent operation or non-operation of the digitizer. Shielded cable is recommended for both serial and parallel data wiring harnesses. Wire and harnesses should be installed in such a way that the weight of the cable bundle does not exert a force on the connector pins. The digitizer is designed to operate with either a +14 or 28 Vdc power source. These voltages may be A+ switched power provided by the transponder or may be provided by the avionics buss. Protect the Trans-Cal encoder with a ½ amp fuse or circuit breaker.

Parallel Data Connection

The outline drawing provides electrical connector pin/function information. Use this data when connecting the digitizer to the transponder. In some installations where older transponders are used, the transponder may not provide an "altitude disable" function. In this case, an instrument panel mounted switch for this function may be required.

Serial Data Connection (Table IX lists the pin assignments for the serial port receptacle.)

Connect the Tx_{D1} through Tx_{D5}³ (transmit data) from the 15-pin D-Subminiature connector to the Rx_D (receive data) port on the GPS or other navigation devices. All

³The selected serial data protocol is transmitted simultaneously on all outputs, unless assigned separately in two groups via **Serial Port Software Configuration** see **§4.6**.

grounds on the 15 pin D-subminiature connector are internally connected to ground and may be used to ground protocol pins, as well as provide data ground to the receiving GPS or other device. Pin 3 (RxD) of the 15-pin serial data connector is used for calibration only. See **Table IX** for connector pin assignments and **§4.6** through **§4.10** for software assigned protocols. Shielded cable is recommended for both serial and parallel data wiring harnesses.

3.3 Serial Altitude Data Port Test Equipment

The output of the serial port may, or may not be directly displayed by the GPS or other device receiving the serial data. There are several ways to test the output of the serial port:

- a) Use a TCI Model ATS-400 Test Set to display the serial altitude data.
- b) Connect to an open serial port on a personal computer using serial data capture software such as PROCOMM™, VERSATERM™, SOFTWARE WEDGE™, TERMINAL (Windows® 3.x) or HYPERTERMINAL (Windows® 95, 98, 2000 or XP.)
- c) Use a dedicated serial data test box such as the BLACK BOX™ RS232 Monitor.
- d) Test for serial output using an oscilloscope to view the 9 Vdc square wave group transmitted about twice a second.

3.4 Parallel ICAO Altitude Data Port Test Equipment

The output of the parallel ICAO altitude data may be monitored by any number of transponder ramp test sets, which allow display of the ICAO altitude digitizer/encoder code. The IFR Model ATC-600A Portable Transponder Test Set is one example. Alternatively, the Trans-Cal Industries' ATS-400 or EET-200 may be used to display the parallel data.

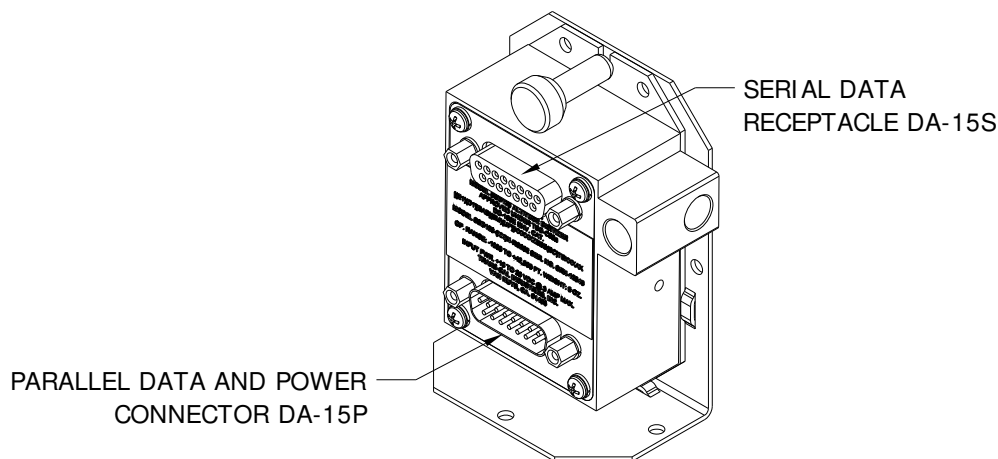

Section 4.0 Calibration and Configuration

4.1 Calibration Overview

**Reference: FAR 91.217; FAA Advisory Circular 43-6B
FAR 91.411; FAR 43-Appendix E and F
FAA TSO-C88a; EASA ETSO-C88a SAE AS8003**

This procedure will allow adjustment to the calibration curve of the SSD120-(XX)N-RS5 or SSD120-(XX)NE-RS5 as an aide in matching the digitizer output to a primary flight altimeter or NIST traceable pressure standard. The maximum allowed error between the primary flight altimeter and the altitude digitizer is ± 125 feet as required by TSO-C88a and ETSO-C88a. All Trans-Cal digitizers are calibrated to within ± 50 feet of a NIST traceable pressure standard; however, the error allowed on altimeters at higher altitudes could lead to a combined error in excess of ± 125 feet. When the altitude digitizer is installed in an aircraft for use as the transponder's source of mode "C" information the digitizer must be recalibrated for correspondence to the aircraft's primary flight altimeter, as required by FAR 91.217 and 91.411. Model SSD120-(XX)N-RS5 and SSD120-(XX)NE-RS5 are designed to be field calibrated to meet this requirement, as per the procedure described in either **§4.4** or **§4.8**. The correspondence required for altitude digitizers is fully addressed in SAE Aerospace Standard AS8003 §3.11. The correspondence described by the SAE standard requires the digitizer to report altitude within ± 125 feet of the primary flight altimeter's reading when the pressure datum is set to 29.92 In. Hg., (1013 MB) absolute. The SAE standard also requires a transition accuracy of ± 75 feet of the nominal transition point for that altitude. A transition is defined as the point at which the digitizer changes from one altitude to the next, either increasing or decreasing altitude. The nominal transition point of the ICAO code occurs 50 feet prior to the altitude in question. See **Figure 1**.

There are two different methods used to change the calibration of this device. The technician need only perform the method that is best suited for the application in question. *There is no need to perform both methods.* The digitizer may be adjusted using two potentiometers, which affect the span and reference of the pressure transducer. This device may also be adjusted utilizing an externally addressable EEPROM, which is configured to accept an alternate error curve entered to the digitizer via an IBM compatible PC.

The **Span Adjust** calibration (**§4.4**) is normally used in applications where only a slight modification is required to bring the altitude digitizer curve up or down.

The **Dynamic Calibration** procedure (**§4.8**) is an alternate method used to match the altitude digitizer to the primary flight altimeter or NIST standard. It assumes the digitizer and altimeter are connected as shown in the **Dynamic Calibration Block Diagram** and the technician may adjust the input pressure to run the digitizer and primary flight altimeter to the same altitude and then enter this altitude into an IBM compatible computer, which will transmit the correction to the digitizer's EEPROM. This calibration procedure differs from the **Span Adjust** procedure in that the adjustments are made at every 1000-foot interval and the Digitizer is adjusted at the 0 foot mark **NOT** the ICAO data nominal transition point.

4.2 Required Equipment Span Adjust

(See span adjust block diagram.)

1. Primary Flight Altimeter.
2. +12 or 28VDC power supply.
3. A pitot-static test set, capable of exercising the altimeter and digitizer over a range of – 1000 feet to the maximum altitude of the digitizer.
4. A ramp checker or test set capable of interrogating the transponder. Optional: ATS-400 or equal device which will allow the display of the 100 foot resolution parallel altitude data.

4.3 Required Equipment Dynamic Calibration

(See dynamic calibration block diagram.)

1. Primary flight altimeter or NIST traceable pressure standard.
2. +12 to 28VDC power supply.
3. IBM compatible computer with an available serial port, OR Trans-Cal Industries ECP-100 Calibration/Programmer.
4. Software requirement: **Windows 98®**, **Windows 2000®** or **Windows XP®** using **Hyper Terminal Ver. 5.0** by Hilgraeve. (Available as a free download at <http://www.hilgraeve.com>) Or equal serial data capture software. See §3.3a. (**Windows Vista®** is not currently supported by Hyper Terminal.)
5. A pitot-static test set, capable of exercising the altimeter and digitizer over a range of -1000 feet to the maximum altitude of the digitizer.
6. *Optional:* ATS-400 or equal device which will allow the display of the 100 foot resolution parallel altitude data.

4.4 Span Adjust Procedure

1. Connect the pitot-static test equipment to the aircraft's static line, and connect the transponder test set per the manufacturer's recommendations. The digitizer's two altitude adjustment potentiometers are identified as L and H, representing low and high altitude. The low adjustment is closest to the edge of the housing, and the high adjustment is closer to the center of the housing.

(Note: Changing either potentiometer will affect the other. An adjustment made to correct the low transition point, will move the high transition point, and require an adjustment of the high potentiometer.)

2. Apply power to the altitude digitizer/transponder.
3. Set the primary flight altimeter barometric pressure adjustment to 29.92 In. Hg. (1013 MB).
4. Interrogate the transponder with the ramp tester, while observing the digitizer ICAO altitude code, decrease pressure to the point where the altitude code just makes a transition to the maximum altitude encoded. Verify that the digitizer is within ± 125 feet of the primary flight altimeter's reading. If not, adjust the high potentiometer until the digitizer transition point is

within ± 30 feet of the nominal transition point. (i.e. while ascending, the digitizer should transition from 29,900 feet to 30,000 feet at 29,950 feet nominally.)

5. Increase pressure until the digitizer's output just makes the transition from 100 feet to 0 feet. Verify that the altitude digitizer reports within ± 125 feet of the primary flight altimeter. If not, adjust the low potentiometer until the transition point is within ± 30 feet of the nominal transition point. (i.e. while descending, the digitizer should transition from +100 to 0 feet at +50 feet nominally.)
6. Repeat steps (4) and (5) until the ± 125 foot tolerance is achieved for both the maximum calibration altitude and the minimum calibration altitude.
7. Exercise the aircraft's static system over the operating range of the altitude digitizer and, with increasing and decreasing pressure, verify at a minimum of ten test points that the altitude digitizer and primary flight altimeter correspond within the ± 125 foot tolerance. Lightly tap the altimeter before each reading to eliminate friction. If correspondence is not achieved at any test point, the altimeter may require calibration.
8. Verify that the digitizer's output is disabled when the transponder is not in mode "C", or when the "Altitude Disable" switch is in the off position.

CAUTION: Always refer to the altimeter and VSI manufacturer's data for maximum rate of climb or descent, and any special test conditions which must be complied with.

Figure 1 Altitude Digitizer Correspondence

Altitude Digitizer to Primary Flight Altimeter
Correspondence
Reference FAA TSO-C88a, EASA ETSO-C88a
and SAE AS8003

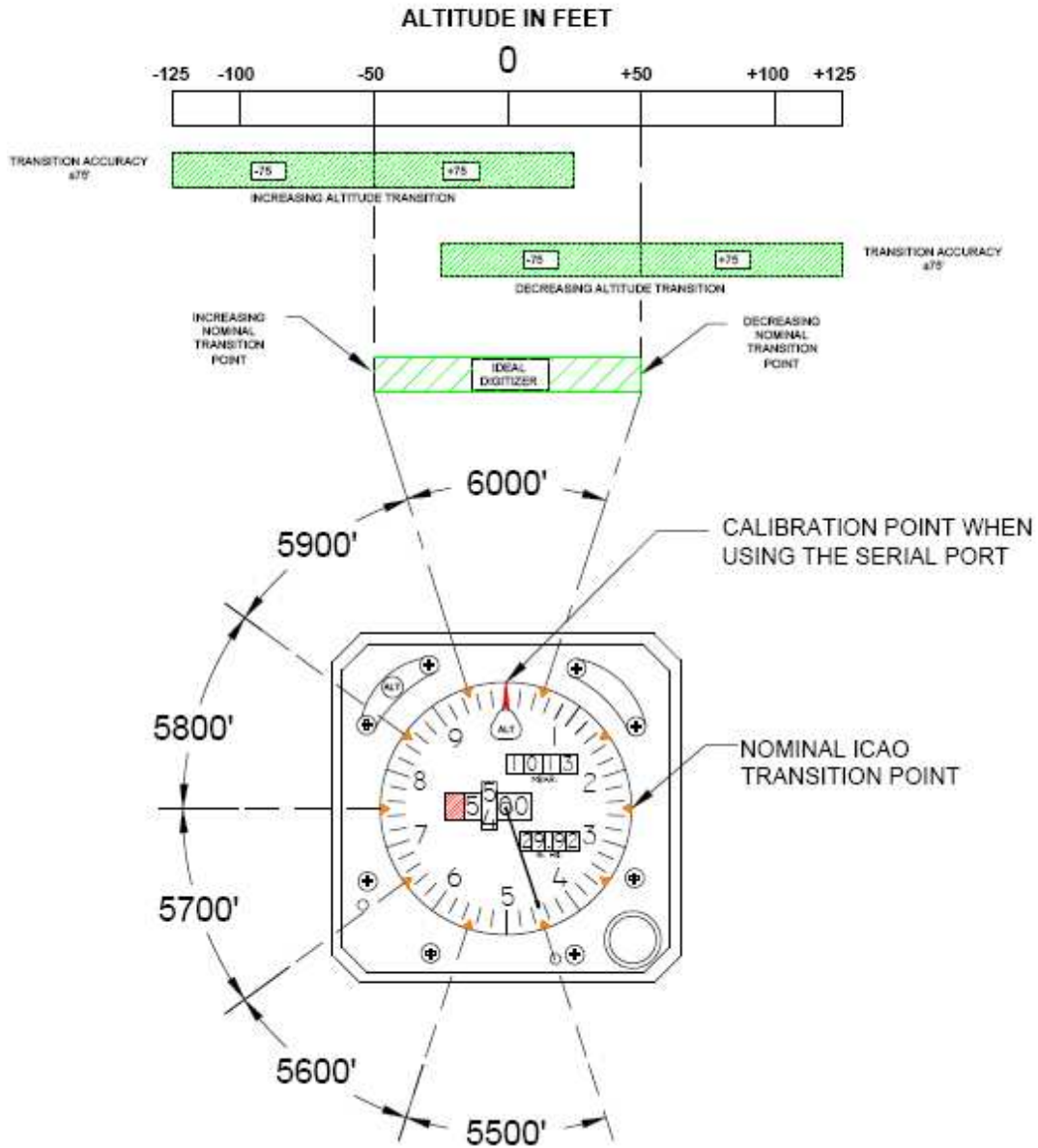

4.5 Dynamic Calibration Adjustment Procedure using the ECP-100

**Reference: FAR 91.217; FAA Advisory Circular 43-6B
FAR 91.423; FAR 43-Appendix E and F
FAA TSO-C88a, EASA ETSO-C88a, SAE AS8003**

This procedure will allow adjustment to the calibration curve of the SSD120-(XX)N-RS5 or SSD120-(XX)NE-RS5 using the ECP-100 as an aide in matching the digitizer output to a primary flight altimeter or NIST traceable pressure standard. This procedure differs significantly from the **Span Adjust Procedure** described in §4.4. The **Dynamic Calibration Procedure** makes adjustments to the altitude data stored in the digitizer's EEPROM. The technician may make adjustments to the digitizer error curve in 1000 foot increments, over the entire operating range with the single exception of the -1000 foot mark. The technician will make the adjustments at the 0 or whole altitude mark, **NOT** at the parallel data's nominal transition point. See **Figure 1**. The digitizer will automatically adjust the ICAO parallel altitude data to transition 50 feet prior to the 0 mark. (i.e. the digitizer's ICAO parallel altitude code will transition from 900 to 1000 feet while the serial altitude data is transmitting 950 feet.)

1. Connect the digitizer, ECP-100, NIST standard or flight altimeter as shown in the **Figure 2** and apply power.
2. Slide the **ECP-100 CAL. PROGRAM** selector to the leftmost **PROGRAM** position.
3. Apply power to the altitude digitizer and slide the **ECP-100** power switch to the on position.
4. Set the altimeter barometric input to 29.92In.Hg. (1013MB). Adjust the static system pressure and stabilize at the first altitude to be calibrated. The first possible correction for Trans-Cal digitizers is at 0 feet. All adjustments to the digitizer calibration curve occur at 1000-foot intervals. Use the **ALTITUDE UP** and **ALTITUDE DOWN** buttons to adjust the **ECP-100** to the current pressure altitude prior to pushing the **INITIATE PROGRAM** pushbutton.
5. Press the **INITIATE PROGRAM** pushbutton once. THE **ECP-100** will enter a digital correction into the digitizer's **EEPROM** at the current pressure altitude.
6. Adjust the input pressure to the next 1000-foot increment and adjust the **ECP-100** to the next 1000-foot increment and repeat step 5. Continue repeating throughout the operating range of the altitude digitizer.
7. Exercise the aircraft's static system over the operating range of the altitude digitizer and, with increasing and decreasing pressure, verify at a minimum of ten test points that the altitude digitizer and primary flight altimeter correspond within the ± 125 foot tolerance. Lightly tap the altimeter before each reading to eliminate friction. If correspondence is not achieved at any test point, the altimeter may require calibration.
8. Verify that the digitizer's output is disabled when the transponder is not in mode "C", or when the "Altitude Disable" switch is in the off position.

NOTE: If an error is entered into the digitizer, adjust the pressure to the correct altitude and re-enter the correction. To clear **ALL** the corrections to the digitizer error curve press the **ALTITUDE UP PROGRAM** pushbutton once. Then press and hold the **ALTITUDE DOWN** button for two seconds.

If the digitizer and flight altimeter are within the ± 125 -foot requirement then no correction is required.

DO NOT adjust the digitizer high and low potentiometers during or after this procedure.

Figure 2 Dynamic Calibration Set-Up Using the ECP-100

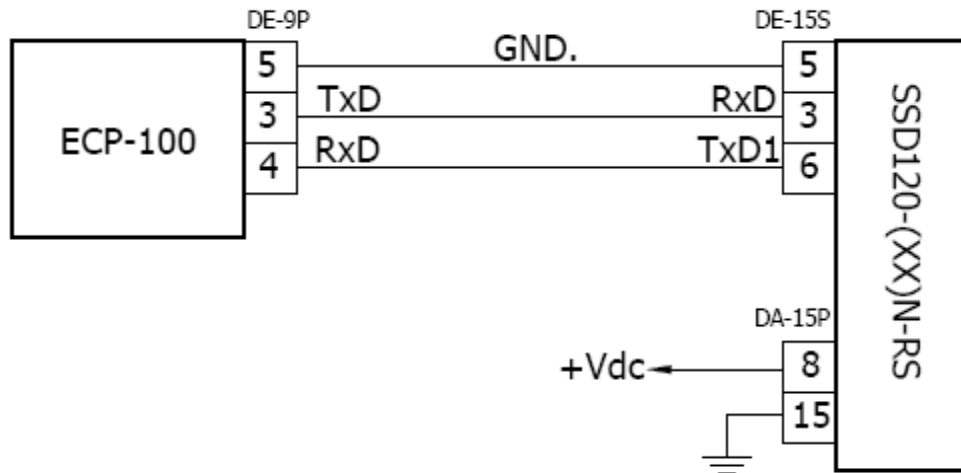
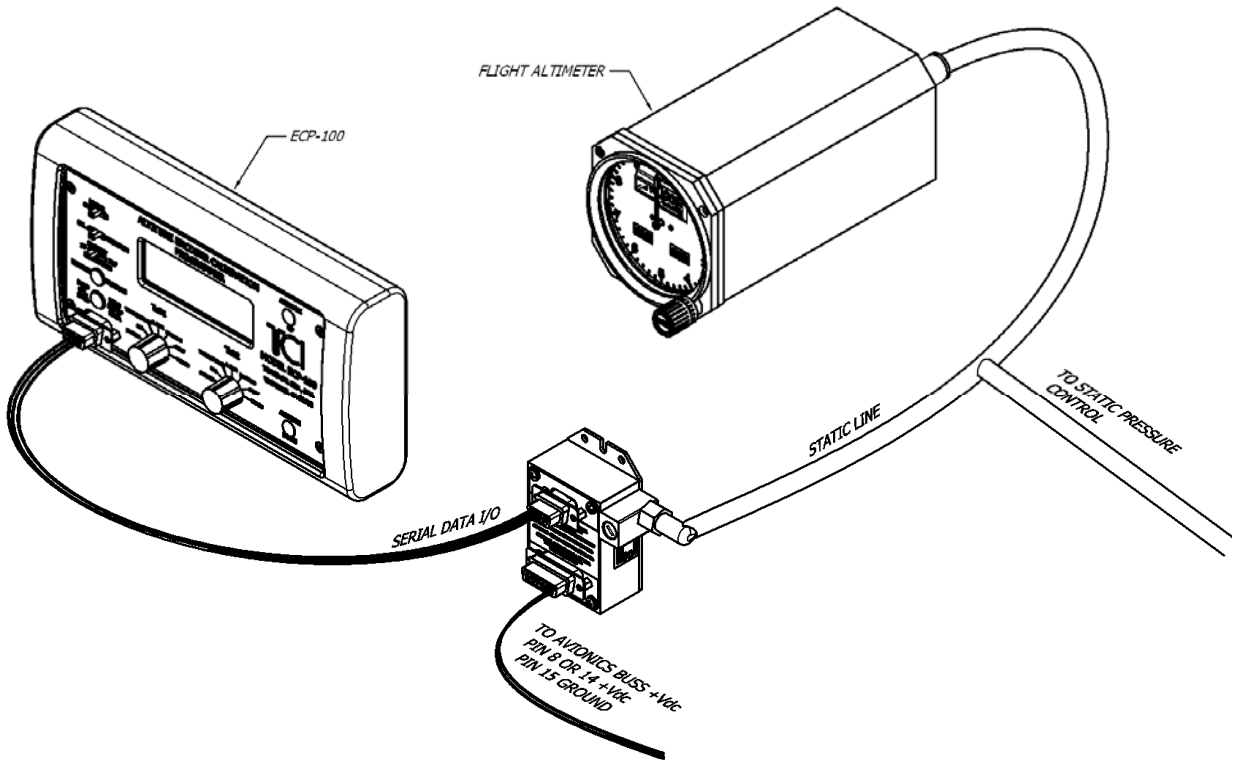

4.6 Hyper Terminal Set-Up on the IBM Compatible PC

Boot up the computer and start the serial data capture software such as the **Hyper Terminal** program. **Hyper Terminal** may be located in the **Programs** section or in the **Accessories** section under **Communications**, and Hyper Terminal will be used for the balance of the examples used in this manual.

Under the **New Connection** window:

Choose an icon then select an identifying title such as "Test."
Select **OK** after you have made your choices.

Under the **Connect to** window:

-Choose **Connect Using Com 1** or whatever **Com** port you have chosen to use.
After your selection click on **OK**.

Under the **Com ? Properties** window:

Select the **Port Settings** tab and set the following:

Bits per second:	9600
Data bits:	8
Parity:	None
Stop Bits:	1
Flow Control:	None

Select **OK**

In the **Hyper Terminal** window select **File** then click on **Properties**.

Under the **Com ? Properties** window click on the **Settings** tab.

Set the following:

Function, arrow, ctrl keys to act as **Terminal Keys**.
Emulation to **Auto Detect**

Under **ASCII Setup**

Set the following:

Echo off.
Wrap lines that exceed terminal width.
Select **OK**.

The software is now configured for operation.

Note: Past versions (Ver. 5 thru 6) of HyperTerminal have a known issue when communicating with serial protocols of 7 data bits, 1 stop bit, odd parity. This Windows® program will not correctly auto detect the protocol, but will display the data when manually configured.

4.7 Serial Port Software Configuration

The SSD120-(XX)N-RS5 incorporates five RS232 compatible outputs, which are configured into two groups. The two serial data groups may be configured via software to transmit two (2) different altitude data protocols simultaneously.

Connect the digitizer to an IBM compatible computer running **HyperTerminal** as described in §4.5 and as shown in the **Dynamic Calibration Block Diagram**. Assign the serial port protocols as follows:

Apply power to the digitizer and after the self-test time has elapsed, altitude data will appear on the PC screen.

Type **<enter>** The digitizer will respond with **?>(current altitude)**

Type **ADJ<enter>** Accesses the digitizer adjustment program.

The Digitizer responds **A=**

Type **P<enter>** To identify the current serial port settings.

The digitizer will respond with a three-digit number as follows:

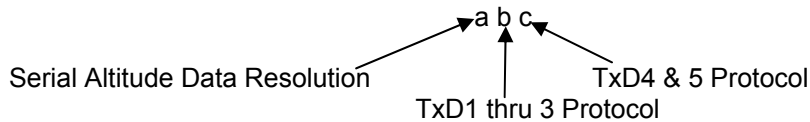

1. The first digit represents the serial altitude data resolution.
 - 0 = Use D-Sub connector protocol hardware jumpers.
 - 1 = 100 foot resolution on all serial outputs.
 - 2 = 10 foot resolution on all serial outputs.
2. The second digit represents the protocol selection for TxD1, TxD2 and TxD3.
 - 0 = Use D-Sub connector protocol hardware jumpers.
 - 1 = UPS Aviation Technologies. 1200bps.
 - 2 = Trimble/Garmin. 9600bps.
 - 3 = Northstar. 2400bps.
 - 4 = Magellan, 1200bps.
 - 5 = ARNAV, 9600bps.
 - 6 = UPS AT 618 Loran 1200 bps. (IIMorrow)
3. The third digit represents the protocol selection for TxD4 & TxD5.
 - 0 = Use D-Sub connector protocol hardware jumpers.
 - 1 = UPS Aviation Technologies. 1200bps.
 - 2 = Trimble/Garmin. 9600bps.
 - 3 = Northstar. 2400bps.
 - 4 = Magellan, 1200bps.
 - 5 = ARNAV, 9600bps.
 - 6 = UPS AT 618 Loran 1200 bps. (IIMorrow)

Software Configuration Example: Type **P215<enter>**

Defined as **10 foot** resolution on all serial data.

UPS Aviation Technologies protocol transmitted on TxD1, TxD2 & TxD3.

ARNAV Systems protocol transmitted on TxD4 & TxD5.

4.8 Serial Port One-Foot Resolution Configuration

The SSD120-(XX)N()-RS232 incorporates five RS232 compatible outputs, TxD4 & TxD5 may be software configured to transmit one-foot resolution data via the following procedure.

Connect the digitizer to an IBM compatible computer running **HyperTerminal** as described in §4.5 and as shown in the **Dynamic Calibration Block Diagram**. Assign the one-foot protocol as follows:

Apply power to the digitizer and after the self-test time has elapsed, altitude data will appear on the PC screen.

Type **<enter>** The digitizer will respond with **?>(current altitude)**

Type **TCICAL<enter>** Accesses the digitizer port assignment program.

The Digitizer responds **T=**

Type **P<enter>** To identify the current port settings.

The digitizer will respond with a two-digit number as follows:

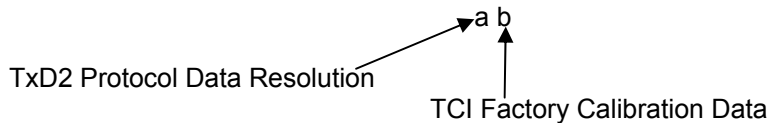

The first digit represents the serial altitude data resolution.
1 = TxD4 & TxD5 standard assignment 10' or 100'.
2 = TxD4 & TxD5 One-Foot Resolution Data

The second digit represents TCI calibration data and is factory set to 2.

Software Configuration: Type **P22<enter>**

Defined as **One-foot** resolution data on TxD3 & TxD4 only.

Type **QQ** to exit the configuration mode and return to normal operation. To view the one-foot resolution data, construct a wiring harness to bring pin 14 or 15 of the serial data receptacle to the receive port of the PC.

NOTE: This change will lock the protocol assignment for TxD4 & TxD5. Jumpers on the connector and software settings will only affect TxD1, TxD2 and TxD3.

4.9 Dynamic Calibration Adjustment Procedure

**Reference: FAR 91.217; FAA Advisory Circular 43-6B
FAR 91.423; FAR 43-Appendix E and F
FAA TSO-C88a, EASA ETSO-C88a, SAE AS8003**

This procedure will allow adjustment to the calibration curve of the SSD120-(XX)N-RS5 or SSD120-(XX)NE-RS5 as an aide in matching the digitizer output to a primary flight altimeter or NIST traceable pressure standard. This procedure differs significantly from the **Span Adjust Procedure** described in §4.4. The **Dynamic Calibration Procedure** makes adjustments to the altitude data stored in the digitizer's EEPROM. The technician may make adjustments to the digitizer error curve in 1000 foot increments, over the entire operating range with the single exception of the -1000 foot mark. The technician will make the adjustments at the 0 or whole altitude mark, **NOT** at the parallel data's nominal transition point. See **Figure 1**. The digitizer will automatically adjust the ICAO parallel altitude data to transition 50 feet prior to the 0 mark. (i.e. the digitizer's ICAO parallel altitude code will transition from 900 to 1000 feet while the serial altitude data is transmitting 950 feet.)

9. Construct a wiring harness per the wiring harness diagram 881404.
10. Connect the digitizer, computer and altimeter or NIST standard as shown in the **Dynamic Calibration Block Diagram**, and energize.
11. Open the **Hyper Terminal** program as described in §4.5.
12. The digitizer output should now be displayed on the PC screen with 10-foot resolution.
13. (You may use the **Hyper Terminal "Clear Screen"** function to remove any extra characters that may be cluttering the screen. Click on **Edit** then click on **Clear Screen**.)

Note: Backspace does not function in **Hyper Terminal**. If a typing error occurs, hit **Q** and begin again.

14. Set the altimeter barometric input to 29.92 In. Hg. Change the input pressure to -1000 feet and begin to compare the altitude digitizer output, as displayed on the computer, to the altimeter reading at every 1000-foot mark. When the digitizer output begins to differ from the altimeter by more than ± 30 feet begin to change the digitizer error curve. (§4.9 provides a table to for the technician to record the changes required and implemented.)

(Note: No digitizer correction is possible at the -1000 foot mark.)

15. Type <enter> the digitizer will respond with ?>(current altitude).
16. Type ADJ <enter> the digitizer will respond with A=.

CAUTION: Always refer to the altimeter and VSI manufacturer's data for maximum rate of climb or descent and any special test conditions which must be complied with.

17. Adjust the input pressure until the altimeter or NIST standard is exactly reading a 1000-foot mark. Note the difference between the digitizer and the altimeter and adjust as follows.

Example:

The altimeter reads 10,000 and the digitizer reports 10,080. Type "**S10 <enter>**"

(S10 represents Set 10,000 feet) The digitizer will now output 10,000 feet based on the current input pressure. The PC will display the altitude at which the digitizer will make this change. In the example referenced above, the PC would display >10000.

18. Proceed to the next 1000-foot mark and repeat the procedure, as in step 8 above, until the entire operating range of the digitizer is completed.

Note:

- a) If no correction is required at an altitude simply do not enter a correction.
- b) Do not adjust the high or low potentiometers during this procedure.
- c) You may quit the adjustment program at any time by typing "Q" twice; the digitizer output will then be displayed on the PC screen in normal operation mode.

19. After completing the above procedure you may examine the corrections entered into the EEPROM. Type "D<enter>" to display the EEPROM data and read the current error curve on the PC screen. The following table should appear:

00= 000	01= 000	02= 000	03= 000	04= 000	05= 000
06= 000	07= 000	08= 000	09= 000	10= 000	11= 000
12= 000	13= 000	14= 000	15= 000	16= 000	17= 000
18= 000	19= 000	20= 000	21= 000	22= 000	23= 000
24= 000	25= 000	26= 000	27= 000	28= 000	29= 000
30= 000	31= 000	32= 000	33= 000	34= 000	35= 000
36= 000	37= 000	38= 000	39= 000	40= 000	41= 000
42= 000	43= 000	44= 000	45= 000		
90= 000	91= 000	92= 000	93= 000	94= 000	95= 000
96= 000	97= 000	98= 000	99= 000		

>current altitude

The first two digits represent altitude x1000 feet and the last three digits after the equal sign represent the amount of error introduced at the altitude in feet.

Note: Fields 90 = 000 through 99 = 000 contain TCI calibration data and are not user accessible.

4.10 Serial Port Software Configuration Using the ECP-100

This procedure will allow the technician to assign separate serial data output protocols to the altitude digitizer output port groups. Connect the ECP-100 to the altitude digitizer as shown in **Figure 3**.

Step 1: With the **ECP-100** and altitude encoder power **off**, Slide the CAL. Program switch to its rightmost **PROGRAM** position and connect the ECP-100 to the altitude encoder, as shown in **Figure 3**.

Step 2: With the **ECP-100** power switch in the **OFF** position, apply power to the altitude encoder, then slide the **ECP-100** power switch to the on position. The **ECP-100** will beep twice then display the current pressure altitude transmitted from the altitude digitizer.

ALTITUDE PROGRAMMER

ALT 00800

Step 3: Push the **READ SET-UP DATA** pushbutton once. The **ECP-100** will display the current serial port protocol settings for 15 seconds, and then return to the altitude programmer display page. The factory setting is pictured below.

DATA = 000
100 Foot Resolution
TxD1= UPS 1200bps
TxD2= UPS 1200bps

TxD1 on the ECP-100 will set the serial data protocol for TxD1, TxD2 and TxD3. While TxD2 on the ECP-100 will set the Serial data protocol for TxD4 and TxD5.

Step 4: Slide the **RESOLUTION** selector to the desired altitude data resolution 10' or 100'.

Step 5: Rotate the TxD1 and TxD2 selector knobs to the desired output protocol. For the purpose of this example we will set TxD1 to transmit the UPS protocol and TxD2 to transmit the Trimble/Garmin protocol.

Step 6: Press the **INITIATE PROGRAM** pushbutton once. The display will beep then flash **PROGRAMMING** and display the protocols to be programmed. Wait until the **ECP-100** emits a long beep and displays **OPERATION COMPLETED** then returns to the **ALTITUDE PROGRAMMER** display.

PROGRAMMING
10 Foot Resolution
TxD1= UPS 1200bps
TxD2= Trimble/Garmin

Step 7: Confirm the port programming by pressing the **READ SET-UP DATA** pushbutton. It should display the settings applied in the previous steps. In the case of our example the display would appear as below.

DATA=212
10 Foot Resolution
TxD1= UPS 1200bps
TxD2= Trimble/Garmin

Step 8: Slide the **ECP-100** power switch to the off position and remove power from the altitude encoder. The encoder is now programmed and ready to operate.

Figure 3 Serial Port Configuration Using the ECP-100

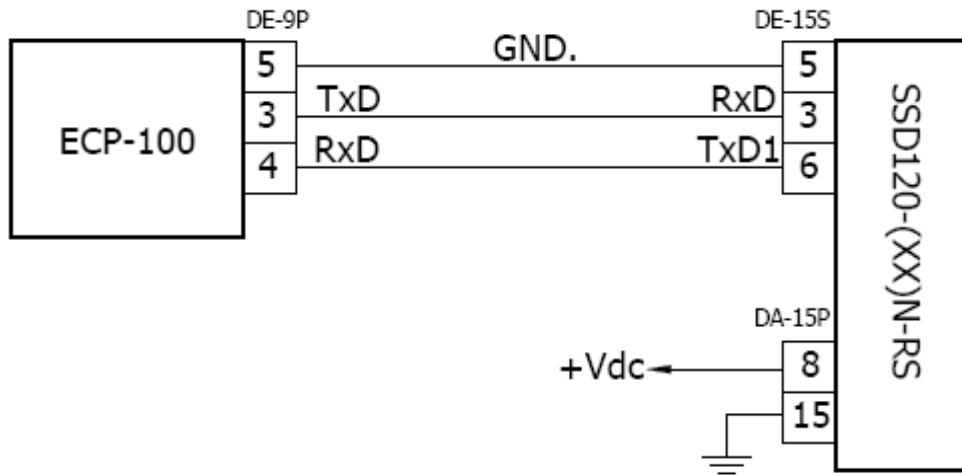
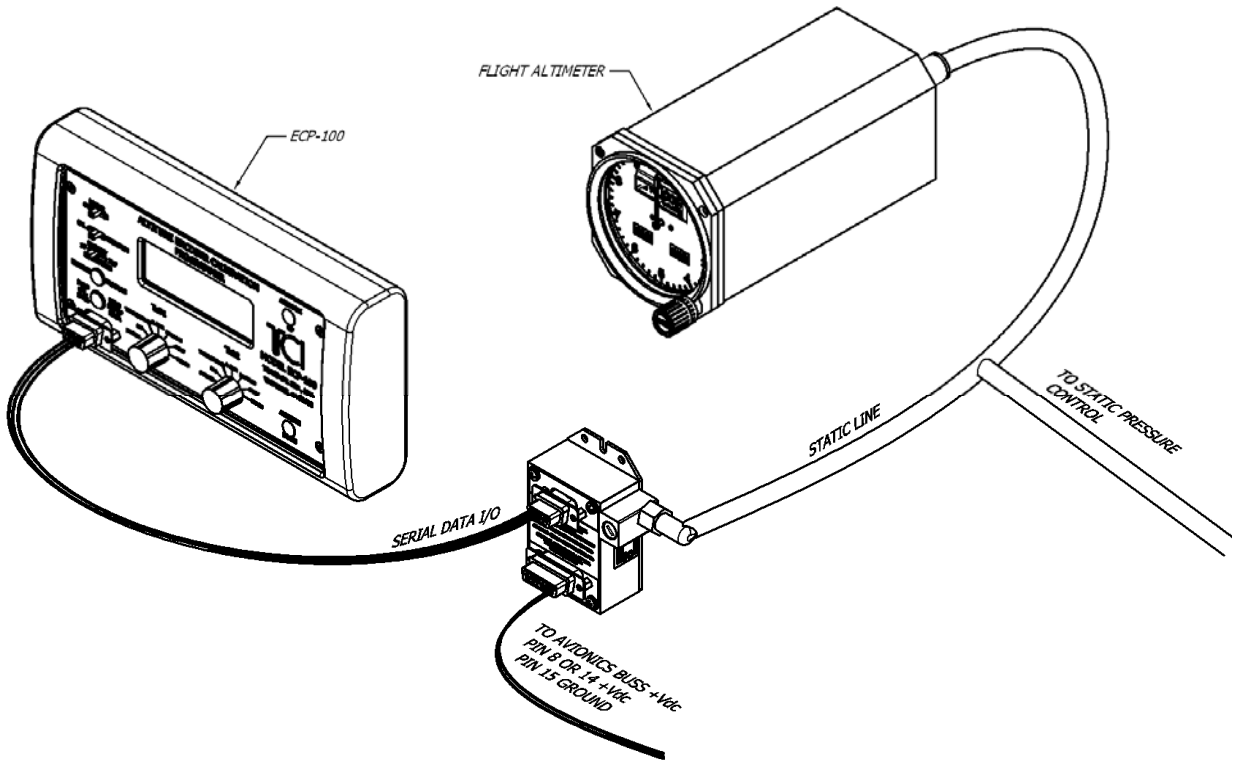

4.11 Configuration and Calibration Command List

Following is a list of commands, which will operate in the **ADJ** and **TCICAL** mode.

Top-Level Menu Commands	Action
ADJ <enter>	Enter Adjustment mode.
TCICAL<enter>	Enter TCICAL mode.
Q	Quit and resume normal operation.

Sub-Menu (ADJ) Commands	Action
CLR <enter>	Clear all EEPROM data.
D <enter>	Display to list all EEPROM error correction table data.
P <enter>	Displays current serial Port settings, see §4.6 Serial Port Software Configuration .
Pabc<enter>	Port protocol assign in ADJ mode, see §4.6 Serial Port Software Configuration .
Pab<enter>	Port protocol assign in TCICAL mode. Factory set to P12 . Set to P22 for One-Foot resolution data on TxD4 & TxD5. See §4.7.
Q	Quit and return to top-level commands.
Saa<enter>	Set digitizer to 1K altitude (aa) mark at current input pressure. See §4.8 Dynamic Calibration Adjustment Procedure .

NOTES:

1. Backspace does not function. If a typing error occurs hit **Q** and begin again.
2. Altitude values 90 to 99 in EEPROM contain factory calibration data and are not customer accessible.
3. A maximum error of ± 499 feet may be introduced at any one altitude.
4. **CLR** clears all error data in the EEPROM, and returns the digitizer to the original factory calibration.
5. **ERR** indicates a syntax error.

4.12 Error Correction Table

Altitude	Correction	Altitude	Correction
-1000		21000	
0		22000	
1000		23000	
2000		24000	
3000		25000	
4000		26000	
5000		27000	
6000		28000	
7000		29000	
8000		30000	
9000		31000	
10000		32000	
11000		33000	
12000		34000	
13000		35000	
14000		36000	
15000		37000	
16000		38000	
17000		39000	
18000		40000	
19000		41000	
20000		42000	

Section 5.0 Tables I through X Digitizer Interconnection

The following digitizer interconnections are provided as a quick reference only, and though they are correct to the best of our knowledge, always consult the latest installation, operation, and service bulletins from the equipment manufacturer.

Table I Bendix/King

SSD120 DA-15P Conn.	Function	Bendix/King KT73 Pin Number	Bendix/King KT76/78 Pin Number	Bendix/King KT76A/78A Pin Number	Bendix/King KXP Pin Number	Bendix/King KXP 755 Pin Number
1	D4	8	*4	*4	V	X
2	A1	M	6	M	G	A
3	A2	K	7	K	H	D
4	A4	J	9	J	J	k
5	B1	E	4	E	K	f
9	B2	C	1	C	L	g
10	B4	B	2	B	M	Y
11	C1	D	3	D	P	U
13	C2	L	8	L	R	T
12	C4	H	10	H	S	W
6	Output Enable	Connect to aircraft ground.	Connect to aircraft ground.	Connect to aircraft ground.	Connect to aircraft ground.	Connect to aircraft ground.
8 or 14 *5	14 to 28Vdc Input.	Connect to aircraft's avionics buss protected by a fuse or circuit breaker.	Connect to aircraft's avionics buss protected by a fuse or circuit breaker.	Connect to aircraft's avionics buss protected by a fuse or circuit breaker.	Connect to aircraft's avionics buss protected by a fuse or circuit breaker.	Connect to aircraft's avionics buss protected by a fuse or circuit breaker.
15	Ground	Connect to aircraft ground.	Connect to aircraft ground.	Connect to aircraft ground.	Connect to aircraft ground.	Connect to aircraft ground.

Serial Data Connection for the Bendix/King KT 73 Transponder

SSD120-(XX)N-RS5 15 Pin Receptacle.	Function	KT 73 24 Pin Conn.
6,8,12,14,15 (Choose One)	TxD to Rx D	7
1, 4, 5, 7, 11, 13	Ground	1 or A
Software select protocol. Select UPSAT 618 Protocol.		

⁴ Data for this connection is not available at this time.

⁵ Pins 8 and 14 are connected internally.

Bendix/King (Honeywell) KT 73 Transponder with Serial Altitude Data Input

The KT 73 must be configured to accept serial altitude data on pin 7 of the main connector, and software configured for *High Resolution M* (IIMorrow). 1200bps, 7 data bits, 1 stop bit and odd parity.

The Trans-Cal SSD120-(XX)N-RS5 must be software configured to transmit the correct serial data protocol to the Bendix/King KT 73 transponder as described below.

1. Connect the SSD120 to an IBM compatible computer running **HyperTerminal** as described in §4.5 and as shown in the **Dynamic Calibration Block Diagram**. Assign the serial port protocols as follows:
2. Apply power to the digitizer and after the self-test time has elapsed, altitude data will appear on the PC screen.

Type: <enter>

The SSD120 will respond with ?>(current altitude)

Type: ADJ<enter>

Accesses the SSD120 adjustment program.
The digitizer will respond with A=

Type: P<enter>

Identifies the current serial port settings.
Default factory setting is 000.

The SSD120 will respond with a three-digit number as follows:

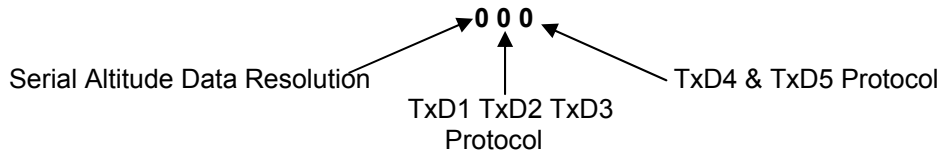

*The first digit represents the serial altitude data resolution.
The second digit represents the protocol selection for TxD1, TxD2 & TxD3.
The third digit represents the protocol selection for TxD4 & TxD5.*

Type: P266<enter>

This selects 10' resolution and transmits the IIMorrow data format/message on all five serial data outputs

Type: P<enter>

The digitizer should return 266>current altitude.
This confirms the change has been stored in the EEPROM.

Type: QQ

The encoder is now configured to transmit the high resolution IIMorrow protocol on all five serial data ports.
REMOVE ALL JUMPERS FROM THE SSD120-(XX)N-RS5 SERIAL DATA D-SUB CONNECTOR!

Table II Cessna, Narco, Microair

SSD120 DA-15P Conn.	Function	Cessna RT359A, RT459A, RT859A Pin Number	Narco AT-150 AT-50, AT-50A Pin Number	Narco AT-6A AT-5, AT-6 Pin Number	Microair T2000
1	D4	10	*6	*6	21
2	A1	14	7	2	9
3	A2	13	6	4	10
4	A4	15	8	8	11
5	B1	19	12	9	12
9	B2	17	10	10	13
10	B4	16	9	11	17
11	C1	21	14	1	18
13	C2	18	11	3	19
12	C4	20	13	5	20
6	Output Enable	11	5	12	Connect to aircraft ground.
8 or 14 *7	14 to 28Vdc Input	9	18	13	2
15	Ground	Connect to aircraft ground.	Connect to aircraft ground.	14	Connect to aircraft ground.

Narco AT-50 and AT-50A Installations

The Narco AT-5A, AT-6A, AT-50 or AT-50A transponder will not accept data from the SSD120-(XX)N-RS5 Altitude Digitizer. A modification to remove the output decoupling capacitors is required and the unit may be ordered from the factory with this modification. Order Model Number SSD120-(XX)N-RS5 with Mod 1.

Please note! The Narco AT-50 and earlier transponder models require a modification before they will function correctly with any altitude encoder. This modification is outlined in Narco Service Bulletin AT-50A-5.

⁶ Data for this connection is not available at this time.

⁷ Pins 8 and 14 are connected internally.

Table III Garmin

SSD120 DA-15P Conn.	Function	Garmin GTX 327 Pin Number	Garmin GTX 330 & 330D Pin Number	Garmin GNC 300 Pin Number	This column left blank intentionally.
1	D4	18	11	N/C ⁸	
2	A1	3	2	15	
3	A2	5	4	16	
4	A4	6	5	17	
5	B1	9	7	18	
9	B2	11	9	19	
10	B4	12	10	20	
11	C1	10	8	21	
13	C2	4	3	22	
12	C4	7	6	23	
6	Output Enable	13 or 25 or aircraft ground	50	Connect to aircraft ground	
8 or 14 * ⁹	14 to 28Vdc Input	14 to 28VDC Input	Pin 62 through a 3 amp 50V reverse rated diode.	Connect to aircraft's avionics buss protected by a fuse or circuit breaker.	
15	Ground	Connect to aircraft ground.	Connect to aircraft ground.	Connect to aircraft ground.	

⁸ Data for this connection not available at this time.

⁹ Pins 8 and 14 are connected internally.

Table IV Garmin

Serial Data Connection for the Garmin GTX327 Transponder

SSD120-(XX)N-RS5 Serial Data Receptacle	Function	GTX327 25 Pin Connector
6, 8, 12, 14, 15 (choose one)	TxD to RxD	19
1,4,5,7,11,13 (choose one)	Data Ground	13 or 25
Protocol: connect pin 10 to ground.		

Serial Data Connection for the Garmin GTX330 and 330D Transponder

SSD120-(XX)N-RS5 Serial Data Receptacle	Function	GTX330 62 Pin Connector
6, 8, 12, 14, 15 (choose one)	TxD to RxD	24 (RS232 In 2)
1,4,5,7,11,13 (choose one)	Data Ground	DataGround
Protocol: connect pin 10 to ground.		

To allow the **Garmin GTX 327, 330 and 330D** transponders to communicate with the SSD120-(XX)N-RS5 go to the **Setup Page** and set the **Altitude Source (ALT SRC)** to receive data in the **Icarus RS232 format**.

Table V Edo-Air, Genave, Collins, Radair

SSD120 DA-15P Conn.	Function	Edo-Air RT-777 Pin Number	Genave Beta 5000 Pin Number	Collins TDR 950 Pin Number	Radair 250 Pin Number
1	D4	15	0	3	15
2	A1	7	4	12	7
3	A2	5	5	10	6
4	A4	3	6	7	13
5	B1	12	7	6	9
9	B2	13	8	5	10
10	B4	14	9	4	11
11	C1	8	10	8	14
13	C2	6	11	11	16
12	C4	4	12	9	12
6	Output Enable	2	3	Connect to aircraft ground.	19
8 or 14 * ¹⁰	14 to 28Vdc Input	Connect to aircraft's avionics buss protected by a fuse or circuit breaker.	2	Connect to aircraft's avionics buss protected by a fuse or circuit breaker.	22
15	Ground	2	Connect to aircraft ground.	Connect to aircraft ground.	Connect to aircraft ground.

¹⁰ Pins 8 and 14 are connected together internally.

Table VI Bendix, Wilcox, UPS AT

SSD120 DA-15P Conn.	Function	Bendix TPR-2060 Pin Number	Bendix TR641A/B Pin Number	Wilcox 1014A Pin Number	UPS AT Apollo SL70 Pin Number
1	D4	*11	N	C	35
2	A1	4	A	k	13
3	A2	6	B	c	31
4	A4	8	C	W	12
5	B1	9	D	T	33
9	B2	10	E	L	14
10	B4	11	F	D	32
11	C1	3	H	P	16
13	C2	5	J	f	34
12	C4	7	K	Z	15
6	Output Enable	Connect to aircraft ground.	Connect to aircraft ground.	Connect to aircraft ground.	Connect to aircraft ground.
8 or 14 *12	14 to 28Vdc Input	Connect to aircraft's avionics buss protected by a fuse or circuit breaker.	Connect to aircraft's avionics buss protected by a fuse or circuit breaker.	Connect to aircraft's avionics buss protected by a fuse or circuit breaker.	Connect to aircraft's avionics buss protected by a fuse or circuit breaker.
15	Ground	Connect to aircraft ground.	Connect to aircraft ground.	Connect to aircraft ground.	Connect to aircraft ground.

Serial Altitude Data Connection for the Apollo SL70 Transponder

SSD120-(XX)N-RS5 Serial Data Receptacle	Function	UPS AT SL70
6, 8, 12, 14, 15 (choose one)	TxD to RxD	4
1,4,5,7,11,13 (choose one)	Ground	3

To allow the **UPS AT SL70** transponder to accept serial data from the SSD120-(XX)N-RS5 go to the **Test Mode** on the **SL70 Conf** page and set the **Altitude Source (ASrc)** to receive **Serial (Ser)** data. On the **BAUD** page select **1200**.

¹¹ Data for this connection is not available at this time.

¹² Pins 8 and 14 are connected internally.

Table VII Becker, Terra, Trig

SSD120 DA-15P Conn.	Function	Becker Avionic Systems ATC3401 ATC2000	Becker Avionic Systems ATC4401	Terra TRT-250 TRT-250D	Trig TT31 Mode S
1	D4	23	20	9	8
2	A1	16	1	5	M
3	A2	15	2	17	K
4	A4	14	3	16	J
5	B1	17	14	15	E
9	B2	19	15	2	C
10	B4	18	16	14	B
11	C1	22	17	3	D
13	C2	21	18	4	L
12	C4	20	19	18	H
6	Output Enable	24	25	12	Connect to aircraft ground.
8 or 14 ¹³	+14 to 28Vdc	6	6	20	Connect to aircraft's avionics buss protected by a fuse or circuit breaker.
15	Ground	24	25	Connect to aircraft ground.	Connect to aircraft ground.

Serial Altitude Data Connection for the Trig TT31 Transponder

SSD120-(XX)N-RS5 Serial Data Conn.	Function	Trig TT31
6, 8, 12, 14, 15 (Choose one)	TxD to RxD	7
1, 4, 5, 7, 11, 13, (choose one)	Ground	A or 1
<i>Digitizer protocol pins 2 and 10 should be connected to ground. Unless software selected in the TCI digitizer set-up.</i>		

The TT31 will accept either parallel or serial altitude data inputs in the Trimble/Garmin data formats. The TT31 will select the parallel inputs if both are connected. Serial data inputs are recommended for better Mode S data resolution. Ground pin 2 to select 10-foot resolution.

¹³ Pins 8 and 14 are connected internally.

Table VIII Honeywell

SSD120 DA-15P Conn.	Function	Honeywell Bendix/King 560EGPWS & MK-XXI EGPWS	Honeywell Bendix/King KGP 860 GA-EGPWS	Honeywell Bendix/King KMH 870 IHAS Processor
1	D4	No connection	No Connection	18
2	A1	12	J1-12	11
3	A2	52	J1-52	10
4	A4	33	J1-33	9
5	B1	14	J1-14	14
9	B2	34	J1-34	13
10	B4	73	J1-73	12
11	C1	32	J1-32	17
13	C2	13	J1-13	16
12	C4	72	J1-72	15
6	Output Enable	Connect to aircraft ground	Connect to aircraft ground	Connect to aircraft ground
8 or 14*¹⁴	+14 to 28Vdc	Connect to avionics buss via circuit breaker	Connect to avionics buss via circuit breaker	Connect to avionics buss via circuit breaker
15	Ground	Connect to aircraft ground	Connect to aircraft ground	Connect to aircraft ground

The Honeywell Bendix/King 860 EGPWS manual lists an RS232 serial altitude data input on pin J1-45 with a data common on pin J1-46. Several TCI compatible serial data protocols are listed, but at the time of this printing, Trans-Cal has not tested the 860 EGPWS data input for compatibility.

¹⁴ Pins 8 and 14 are connected internally.

Tables IX and X Serial Data Connector and Protocol Selection

Table IX

SSD120-(XX)N-RS5 Serial Data Port Receptacle, DA-15S

Pin	Function
1	Ground ¹⁵
2	Ground for 10' resolution.
3	RxD (Calibration Only)
4	Ground ¹⁵
5	Ground ¹⁵
6	TxD1 (Group A) ¹⁶
7	Ground ¹⁵
8	TxD2 (Group A) ¹⁶
9	Protocol
10	Protocol
11	Ground ¹⁵
12	TxD3 (Group A) ¹⁶
13	Ground ¹⁵
14	TxD4 (Group B) ¹⁶
15	TxD5 (Group B) ¹⁶

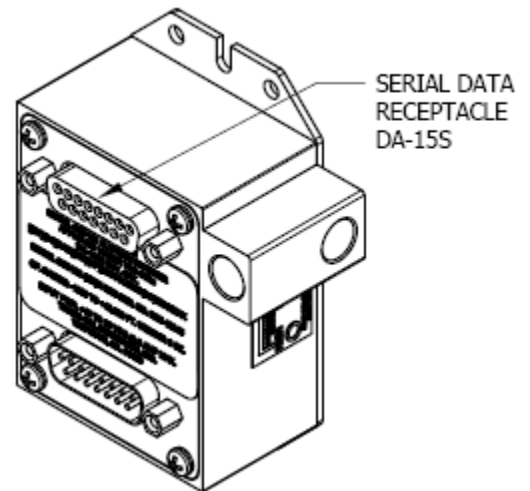

Table X

SSD120-(XX)N-RS5 Protocol Selection: DA-15S D-Sub Serial Data Receptacle Function Table

Protocol Selection	Pin 2	Pin 9	Pin 10
UPS AT 100' resolution, 1200bps. UPS AT 10' resolution, 1200bps.	Open Gnd.	Open Open	Open Open
Trimble/Garmin, 100' resolution, 9600bps. Trimble/Garmin, 10' resolution, 9600bps.	Open Gnd.	Open Open	Gnd. Gnd.
Northstar/Garmin, 100' resolution, 2400bps. Northstar/Garmin, 10' resolution, 2400bps.	Open Gnd.	Gnd. Gnd.	Open Open
Magellan, 100' resolution, 1200bps. Magellan, 10' resolution, 1200bps.	Open Gnd.	Gnd. Gnd.	Gnd. Gnd.
ARNAV Systems (Software selectable ONLY)	Open	Open	Open
UPS AT 618 Loran Systems (Software selectable ONLY)	Open	Open	Open

¹⁵ Pins 1, 4, 5, 7, 11, and 13 are internal grounds provided for protocol selection and serial data ground.

¹⁶ TxD1, TxD2, TxD3, TxD4 and TxD5 are five (5) RS232 outputs which will transmit the protocol selected by grounding the pins above, or will transmit separate protocols in two groups as assigned via software, see **§4.6 Serial Port Software Configuration**.

Section 6.0 GPS/MFD & Miscellaneous Connection Data

Given the speed with which new GPS and MFD units are entering the market, it is impossible to provide data on every device. The following digitizer/GPS interconnections are provided as a quick reference only, and though they are correct to the best of our knowledge, always consult the latest installation, operation, and service bulletins from the GPS or MFD manufacturer.

6.1 UPS Aviation Technologies (IIMorrow)

Apollo Model GX50, GX60, GX65

Apollo GX50, GX60, GX65 Signal	Apollo 37 Pin D-Sub Connector	SSD120-(XX)N-RS5 Serial Data D-Sub Receptacle
RxD2	21	6, 8, 12, 14, 15 (choose one)
Ground	20	1, 4, 5, 7, 11, 13 (choose one)
		<i>Optional, jumper pin 2 to ground for 10' resolution.</i>

Apollo GX50, GX60, GX65 Software Configuration

In test mode, rotate the **Large** knob to select serial port configuration **RX**. Press **SEL**, rotate the large knob to select the **RxD2** port, rotate the small knob to select **AltEnc** input.

Apollo Model MX20 Multi Function Display

Apollo MX20 Signal	Apollo 37 Pin D-Sub Connector	SSD120-(XX)N-RS5 Serial Data D-Sub Receptacle
RxD2	21	6, 8, 12, 14, 15 (choose one)
Ground	3	1, 4, 5, 7, 11, 13 (choose one)
		<i>Optional, jumper pin 2 to ground for 10' resolution.</i>

Apollo MX20 Software Configuration

Under External Data Source set altitude source to **Port 2**.

6.2 Trimble

Trimble 2101 Approach Plus GPS Receiver

Trimble Signal	Trimble 2101 Port 1	Trimble 2101 Port 2	SSD120-(XX)N-RS5 Serial Data D-Sub Receptacle
RxD+	7	24	1, 4, 5, 7, 11, 13 (choose one)
RxD-	8	36	6, 8, 12, 14, 15 (choose one)
Ground	3 or 20	3 or 20	1, 4, 5, 7, 11, 13 (choose one)
			Protocol assignment, jumper pin 10 to ground.
			<i>Optional, jumper pin 2 to ground for 10' resolution.</i>

Trimble 2101 Approach Plus GPS Receiver Software Configuration - Installation Setup

Access the 2101 installation setup submenu and go to the SERIAL I/O SETUP. Select the GPS serial port which is to receive the pressure altitude data, **SERIAL-1 IN** or **SERIAL-2 IN**. Set data format to **ENCODER**.

2101 I/O Approach Plus GPS Receiver

Trimble Signal	Trimble 2101 I/O Serial Port 1	Trimble 2101 I/O Serial Port 2	SSD120-(XX)N-RS232 Serial Data D-Sub Receptacle
RxD+	J1-7	J1-24	1, 4, 5, 7, 11, 13 (choose one)
RxD-	J1-8	J1-36	6, 8, 12, 14, 15 (choose one)
Ground	J1 - 3 or 20	J1 - 3 or 20	1, 4, 5, 7, 11, 13 (choose one)
			Protocol assignment, jumper pin 10 to ground.
			<i>Optional, jumper pin 2 to ground for 10' resolution.</i>

2101 I/O Approach Plus GPS Receiver Software Configuration - Installation Setup

Access the 2101 installation setup submenu and go to the SERIAL I/O SETUP. Select the GPS serial port, which is to receive the pressure altitude data, **SERIAL-1 IN** or **SERIAL-2 IN**. Set data format to **ENCODER**.

6.3 Garmin International

Garmin 400 and 500 Series GPS Devices (Includes 430W and 530W)

Garmin 78 Pin Conn. (P4001)	SSD120-(XX)N-RS5 Serial Data Receptacle
57	6, 8, 12, 14, 15 (choose one)
77 or 78	1, 4, 5, 7, 11, 13 (choose one)
Protocol, jumper pin 7 to ground.	
<i>Optional, jumper pin 2 to ground for 10' resolution.</i>	

Garmin 400 series GPS software configuration

To allow the **Garmin 400 series GPS** to communicate with the SSD120-(XX)N-RS5 go to the **Main RS232 Config** page and set channel 1 input to **Icarus-alt**.

Garmin GNC 300 GPS/Comm

GNC 300 37 Pin Connector J101	Function	SSD120-(XX)N-RS232 15 Pin Serial Data Receptacle
17	RxD to TxD	6, 8, 12, 14, 15 (choose one)
26 or 22	Data Ground	1, 4, 5, 7, 11, 13 (choose one)
		Protocol: connect pin 10 to ground.
		<i>Optional, jumper pin 2 to ground for 10' resolution.</i>

To allow the **Garmin 300 series GPS/Comm** to communicate with the SSD120-(XX)N-RS5 go to the **I/O Test Page** and set channel 1 input to **Icarus-alt**.

6.4 ARNAV Systems, Inc.

ARNAV Systems 5000 Series Multi-Function Display

ARNAV 5000 25 Pin Connector	SSD120-(XX)N-RS5 Serial Data Receptacle
15	6, 8, 12, 14, 15 (choose one)
13 or 25	1, 4, 5, 7, 11, 13 (choose one)
Protocol, Software select ARNAV protocol see §4.6 .	

ARNAV Systems GPS-505/506/512 GPS Sensor

ARNAV GPS-505/506/512 DB-25 Connector	SSD120-(XX)N-RS5 Serial Data Receptacle
8	6, 8, 12, 14, 15 (choose one)
9	1, 4, 5, 7, 11, 13 (choose one)
Protocol, Software select ARNAV protocol see §4.6 .	

ARNAV Systems DR-100 WxLink Receiver/ Multiplexer

ARNAV DR-100 25 Pin Connector	SSD120-(XX)N-RS5 Serial Data Receptacle
10	6, 8, 12, 14, 15 (choose one)
13 or 25	1, 4, 5, 7, 11, 13 (choose one)
Protocol, Software select ARNAV protocol see §4.6 .	

SSD120-(XX)N-RS5 Software Configuration Note for Use with ARNAV Devices

The SSD120-(XX)N-RS5 *must* be software configured per **§4.6** to operate with ARNAV system devices. Ensure that all hardware jumpers are removed from the serial data connector. Hardware jumpers on the Serial Data Receptacle (DA-15S) *will override* any software settings.

6.5 Century Flight Systems

Digital Altitude Preselect/Alerter 1D960 ICAO Parallel Input		
SSD120 Pin	Function	1D960 Pin
1	D4	9
2	A1	25
3	A2	40
4	A4	10
5	B1	26
6	STROBE	Connect to Ground
7	D2	39
8	PWR	--
9	B2	22
10	B4	7
11	C1	23
12	C4	8
13	C2	38
14	PWR	--
15	GROUND	--

Digital Altitude Preselect/Alerter 1D960 ICAO Serial Altitude Data Input	
1D960 Connector CD-245	SSD120-(XX)N-RS5
30	9
33	1 or 5 or 8
<i>TxD2 must be programmed for 1' resolution.</i>	

Section 7.0 Instructions for Continued Airworthiness

The SSD120-(XX)N-RS5 is an all solid-state device and requires no periodic maintenance to maintain its airworthiness. The altitude encoder is to be tested during the aircraft biennial transponder and pitot-static system test as required by Federal Aviation Regulations. If the altitude encoder reports an error in excess of ± 125 feet when compared to the primary flight altimeter, then recalibration as per §4.0 of this manual is required. If the error cannot be corrected through this procedure, then the unit is to be repaired or replaced. Contact Trans-Cal Industries for further information.

Section 8.0 Adapter Plate Ordering Information

The adapter plates listed below will allow the use of competing digitizer manufacturer's and older Trans-Cal quick release mounting trays with the SSD120-(XX)N-XXXXX. These adapter plates are designed to allow for quick replacement of altitude encoders.

Manufacturer Model	TCI Adapter Plate Part Number
ACK Model A-30	103059
Ameri-King Model AK350 Series	103061
Narco Model AR-500	No adapter required.
Narco Model AR-850	103038 (same as TCI plate below)
Shadin Model 8800-X Series	103060
Sandia Model SAE5-35	103035
Trans-Cal Model D120-P2-T	103036
Trans-Cal Model SSD120-(XX)A	103038

Pictured below is the SSD120-(XX)N-RS5 mounted on adapter plates and quick release mounting trays for several competing devices. Quick release mounting trays are NOT included with the adapter plates.

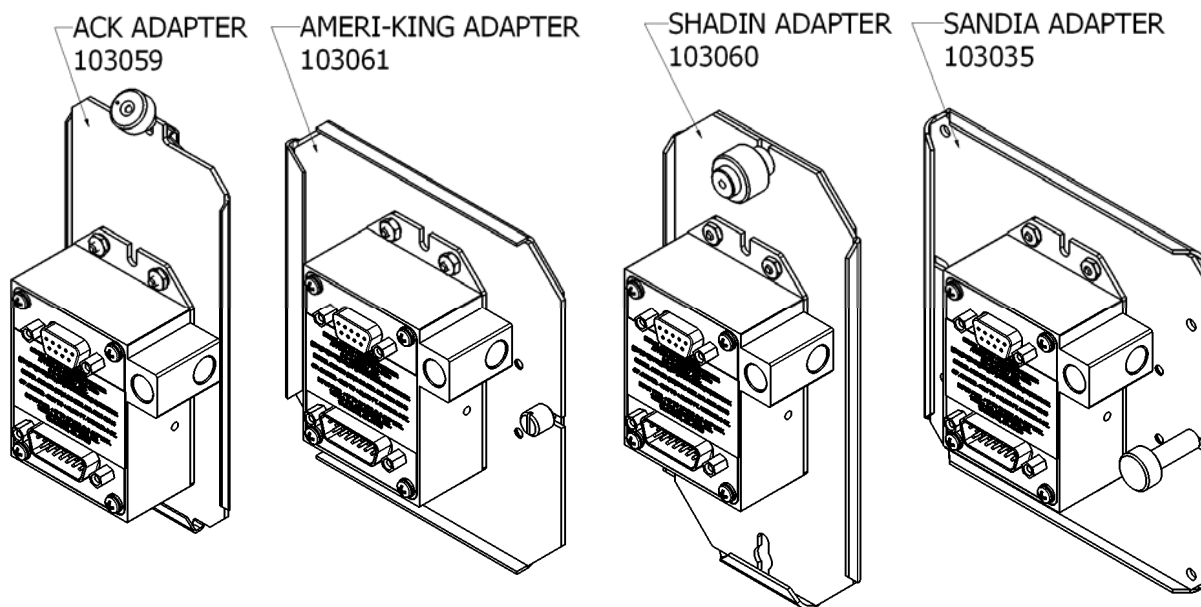

Section 9.0 Frequently Asked Questions

1. *How often must the Altitude Digitizer be calibrated; is there periodic maintenance required?*

There is no periodic maintenance required. The Digitizer is tested and calibrated, if required, during the aircraft's biennial certification of the transponder and static system.

2. *How many devices may be driven off of the parallel ICAO Altitude data port?*

The number of devices that may be connected to the Digitizer ICAO altitude output is a function of the current and power required. The Digitizer parallel data outputs are "uncommitted" collectors of a transistor array which are "pulled-up" through a resistive load by the transponder (or other device) to some positive voltage. This voltage may range from about +3 to +40Vdc. Each Digitizer data output line (i.e. D4, A1, A2, A4 etc.) is capable of providing 35 mA (0.035 Amperes) with a "not to exceed" power rating of 100mW (0.1 Watts), when it is "sinking" current in the "on" position. Typical modern applications require about 1 milliampere or less per data line, per device.

In the circuit illustrated below, the current is calculated as 0.9mA at 8.1mW. At this current and power rating, a total of 12 identical devices could be connected to the digitizer. *Given the wide variety of input circuits capable of interfacing with the Digitizer and the possibility of cross-talk, careful planning of the electrical loads acting upon the Digitizer output is advised.*

$$V/R = I \quad 9Vdc / 10000 \text{ Ohms} = 0.0009 \text{ Amps}$$

$$V(I) = P \quad 9Vdc \times 0.0009 \text{ Amps} = 0.0081 \text{ Watts}$$

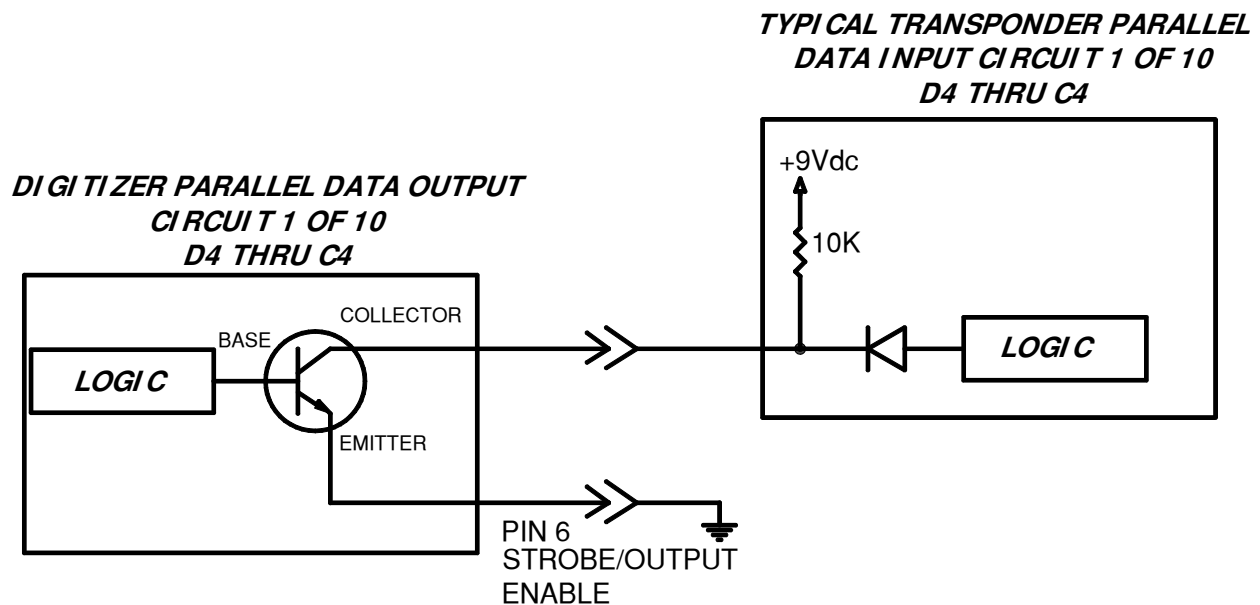

3. Why do altitude encoding errors occur when connecting a second or third device to the altitude encoder, but not when only one device is connected?

This is a symptom of "Cross-Talk." This condition typically occurs when the devices connected to the altitude encoder are "pulling-up" to different voltages without diode isolation. When the altitude encoder is in the "off" state the data line electrical current may flow in undesired directions due to this pull-up voltage imbalance. Most modern avionics devices are diode isolated, but in applications where older equipment is mixed with new devices, blocking diodes may be required to isolate the older device. Germanium or Schottky blocking diodes are the preferred devices to install due to the low forward voltage drop across the device. Connect as detailed in the illustration below. Use of general purpose silicon diodes are *NOT* recommended, as the larger voltage drop may interfere with the logic threshold detection in the equipment.

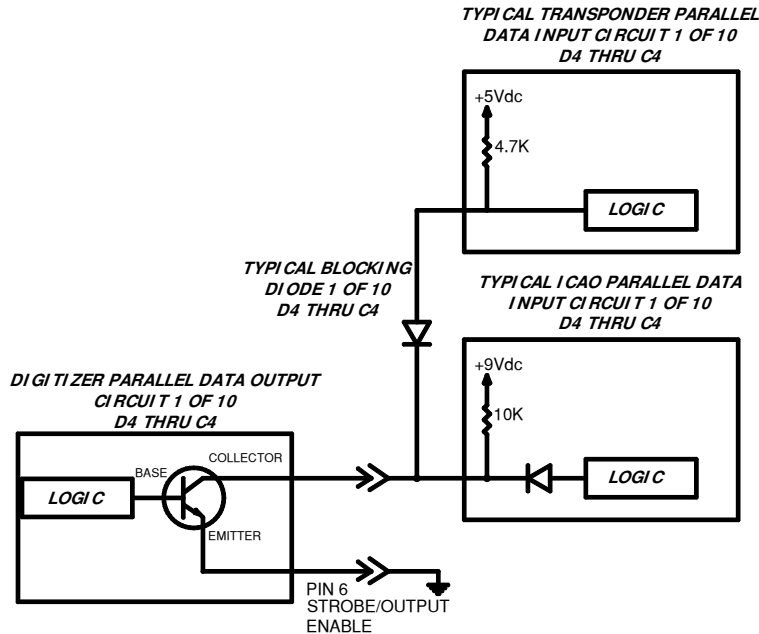

4. My transponder does not have a D2 or D4 input. What do I do with these signals from the Digitizer?

Leave unused data bits unconnected.

5. What is the **Strobe** or **Signal Common** or **Output Enable** function on the ICAO altitude data port?

This is a control signal for the ICAO parallel altitude data. On devices manufactured by Trans-Cal this function is always on pin 6 of the ICAO altitude port. A "high" or "open" on this pin will disable the ICAO altitude data. A "low" or "ground" on this line will enable the altitude data. Some interconnecting devices may use this signal to control the flow of data from the Digitizer. Be aware that when using this signal and connecting multiple devices to the Digitizer, interruptions of the ICAO data will occur when the controlling device "strokes" the Digitizer.

6. On Altitude Digitizers with serial ports, does the strobe function control the serial data?

No, the serial data is independent of the parallel ICAO altitude data. Transmission of the serial data is asynchronous. Enabling or disabling the parallel data will not affect the serial data transmission.

7. *Must the parallel ICAO altitude data be connected to use the serial data?*

No, the serial data output is completely independent of the parallel data output. However, power must be supplied to the Digitizer through the ICAO altitude data connector.

8. *How many devices may be driven off of the RS232 output?*

One device may be driven off each serial output. The SSD120-(XX)N-RS5 Digitizer provides five RS232 outputs, so five RS232 receiving devices may be driven off of each Digitizer.

9. *Can the Digitizer transmit two different serial data protocol messages at the same time?*

Yes. The five digitizer RS232 ports are divided into group A (TxD1, TxD2, TxD3) and group B (TxD4 & 5.) The Digitizer may be configured via the serial port and an IBM compatible PC to specify the data protocol to be transmitted on each serial output *group*. **See §4.6.**

10. *What is the maximum length of an RS232C wiring harness?*

25 feet.

11. *I have connected the serial data from the digitizer to my GPS device, why does the GPS display a “No Pressure Altitude” message?*

There are several possible problem sources.

Electrical Ground Imbalance

RS232 operates in an “unbalanced” (single-ended) transmission method; where the receiving device monitors the difference between the signal voltage and a common ground. If a significant difference in electrical ground potential between the Digitizer and the receiving device exists, then the RS232 signal levels may be adversely affected. Verify the digitizer and receiving device electrical grounds are referenced together by connecting one of the ground pins on the Digitizer RS232 connector to the receiving device's ground.

Receiving Device Configuration

The receiving device is looking for a specific message at a specific baud rate and parity. These messages, baud rates and parity vary from manufacturer to manufacturer. A mismatch on any one of these items will cause a communication failure. In addition, many devices are capable of software configuration to accept RS232 data on different connector pins. Verify the following:

- a. Digitizer data is routed to the correct connector pin on the receiving device.
- b. The receiving device is software configured to accept data on that connector pin.
- c. The receiving device is software configured to accept the correct message protocol at the correct baud rate and parity.
- d. The Digitizer is transmitting the same message, baud rate and parity as configured in item c above.

12. *How can I verify the RS232 data message, baud rate and parity transmitted from the Digitizer?*

- a. Use the Trans-Cal ATS-400 Test Set to display the RS232 data.
- b. Substitute the Trans-Cal ADS-100 for the altitude encoder to simulate the serial data transmission.
- c. Use a PC with an open RS232 port and serial data capture software. Some possible software solutions include: HYPER TERMINAL (Windows® 95 & 98 & XP), SOFTWARE WEDGE™, PROCOMM™, VERSATERM™.
- d. Use a dedicated serial data test box such as the BLACK BOX™ RS232 MONITOR.
- e. An oscilloscope may be used to view the 9Vdc square wave transmitted about 2/second.

Section 10.0 Known Compatibility Issues

10.1 Honeywell KT 73 Transponder with Serial Altitude Data Input

The **KT 73** must be configured to accept serial altitude data on pin 7 of the main connector, and software configured for *High Resolution M* (IIMorrow). 1200bps, 7 data bits, 1 stop bit and odd parity. The Trans-Cal **SSD120-(XX)N-RS5** must be software configured to transmit the correct serial data protocol to the Bendix/King KT 73 transponder as described in **§5.0** of this manual.

10.2 Narco AT5A, AT6A, AT-50 and AT-50A Installations and SSD120-(XX)N Mod.1

The Narco AT-5A, AT-6A, AT-50 or AT-50A transponder will not accept data from the SSD120-(XX)N-RS5 Altitude Digitizer. A modification to remove the output decoupling capacitors is required and the unit may be ordered from the factory with this modification. Order Model Number SSD120-(XX)N with Mod. 1. **Please note! This modification may NOT be performed in the field. Please also note!** The Narco AT-50 and earlier transponder models require a modification to the strobe circuit before they will function correctly with any altitude encoder. This modification is outlined in Narco Service Bulletin AT-50A-5.

10.3 “Mod. 1” Installations

SSD120-(XX)N-RS5 Mod.1 Altitude digitizers lack decoupling capacitors on the ICAO altitude data line outputs to enable operation with older Narco transponders. When installing a Mod. 1 unit in an aircraft, and ***particularly when installing in composite structured aircraft***, great care should be taken to insure that the digitizer is located away from RF emitting devices and fields. The interconnecting data harness must be shielded and properly grounded. Additional shielding around the digitizer may be required to prevent stray RFI from disrupting the digitizer’s analog signal sensing electronics.

10.4 King KT-75

The King KT-75/75R uses the old RTL (resistor transistor logic) pulling up to about 3 volts; consequently the open collectors of the SSD120-(XX)N will not pull the signal past the KT-75 logic threshold.

10.5 S-Tec (Collins) TDR950

The TDR950 must be powered-up first, or the SSD120-(XX)N must be diode isolated to prevent the TDR 950 from invalidating the encoder data. All diodes are type 1N4454 (CPN 353-3741-010).

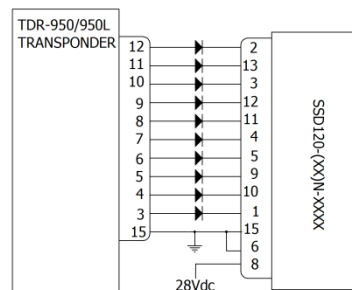

10.6 Trans-Cal SSD120-(XX)N Backwards Compatibility

All Model SSD120-(XX)N-XXXX are pin-for-pin replacements for all Model SSD120-(XX) and D120-P2 T, with ONE exception. The older SSD120-(XX) utilized a 28V heater ground on pin 1 of the D-Subminiature connector. Pin 1 is the D4 data bit on the SSD120-(XX)N models. Rewire the harness appropriately, if D4 is an active bit. No action is required if D4 is unused. All Model SSD120-(XX)N-XXXX are pin-for-pin replacements for all Model SSD120-(XX)A-XXXX.

10.7 SSD120-(XX)N-RS5 Compatibility to Competitor's Products

Manufacturer	Compatibility with Model SSD120-(XX)N-RS5
ACK Technologies	Model A-30 Pin-for-pin compatible.
Ameri-King Corp.	Model AK-350 Pin-for-pin compatible.
Becker Avionic Systems	BE6400-01-(XX) Utilizes an RS422 interface and is not compatible with Trans-Cal encoders.
Narco	Model AR-850 Pin-for-pin compatible.
Narco	Model AR-500 Uses a 25 Pin D-Sub connector and must be rewired to use SSD120-(XX)N-RS5.
Rocky Mountain Instrument	Model μ Encoder no display function and requires rewiring the harness to use SSD120-(XX)N-RS5.
Shadin	See chart below.
Sandia	Model SAE5-35 ICAO data is pin-for-pin compatible, RS232 data must be rewired to use SSD120-(XX)N-RS5.
Terra	Model AT3000 is pin-for-pin compatible.

Manufacturer	Compatibility with Model SSD120-(XX)N-RS5
Shadin Model 8800M	ICAO data is pin-for-pin compatible, RS232 data is output on pin 7. Rewire to use TCI 15 pin serial data receptacle. Configure for UPS AT serial data message §1.8.1 of this manual.
Shadin Model 8800G	ICAO data is pin-for-pin compatible, RS232 data is output on pin 7. Rewire to use TCI 15 pin serial data receptacle. Configure for Magellan serial data message §1.8.4 of this manual.
Shadin Model 8800T	ICAO data is pin-for-pin compatible, RS232 data is output on pin 7. Rewire to use TCI 15 pin serial data receptacle. Configure for Trimble serial data message §1.8.2 of this manual.
Shadin Model 8800A	ICAO data is pin-for-pin compatible, RS232 data is output on pin 7. Rewire to use TCI 15 pin serial data receptacle. Configure for ARNAV serial data message §1.8.5 of this manual.

Wiring Harness Diagram Part Number 881404

SSD120
15 PIN
D-SUB
CONN.

IBM PC
9 PIN
D-SUB
CONN.

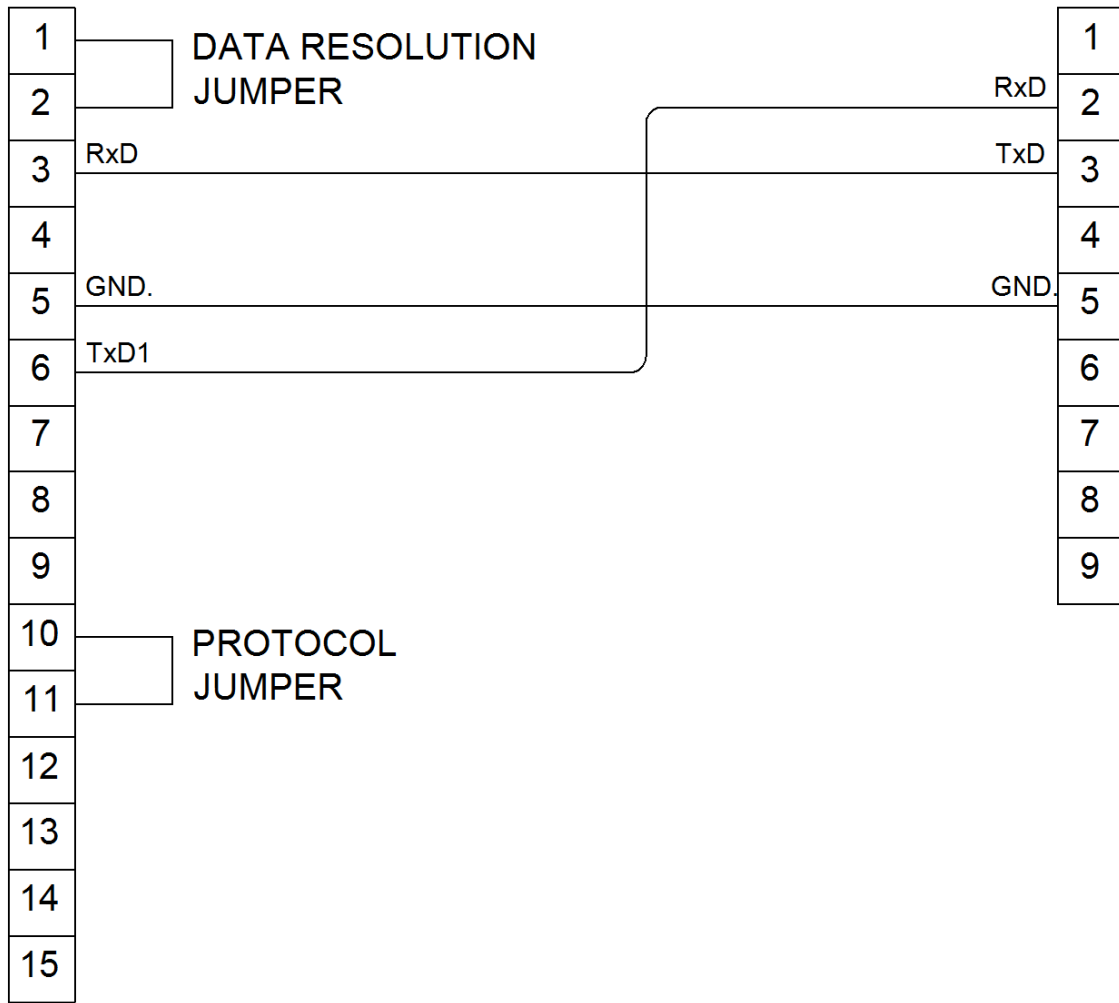

Span Adjust Block Diagram

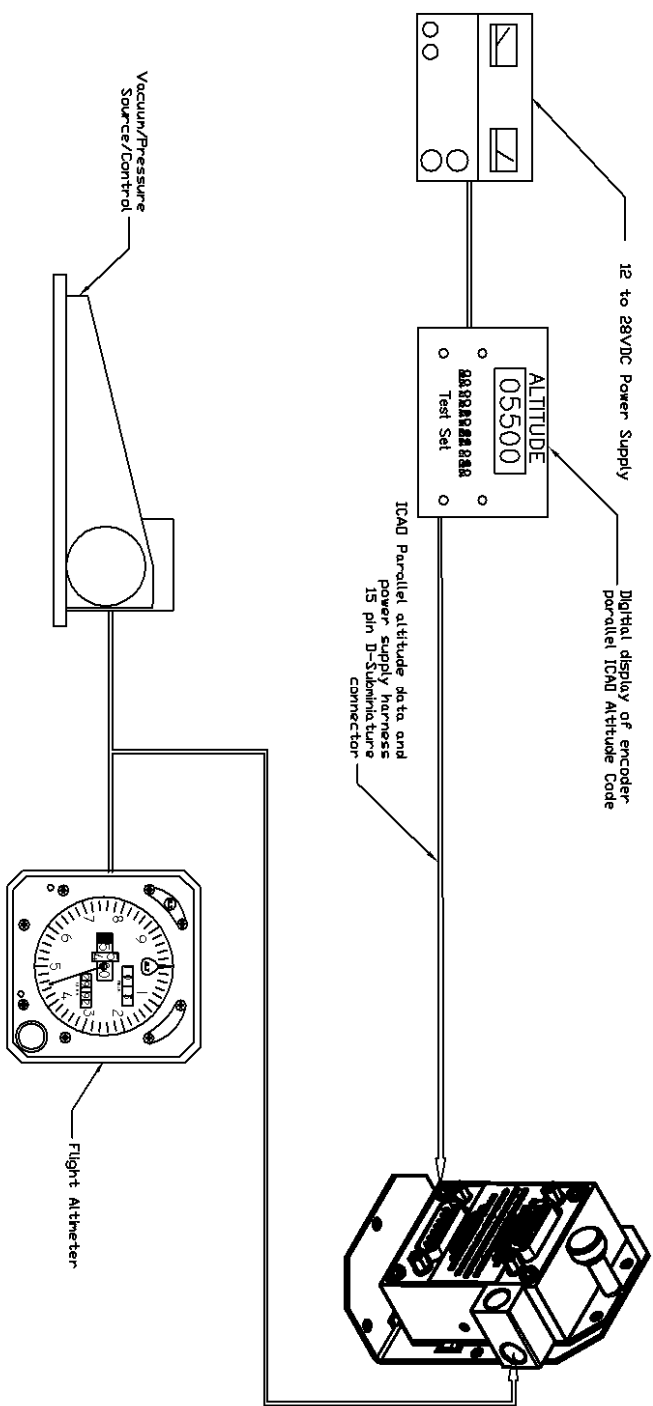

SSD120-(XX)N(-) -RSS
Parallel Data and Power Connector
15 Pin D-Sub Connector

Pin	Function	Pin	Function
1	D4*	8	B2
2	A1	10	B4
3	A2	11	C1
4	A4	12	C4
5	B1	13	C2
6	Stroke	14	14/28V Innd
7	Stroke	15	Ground
8	14/28V Input		

*Used above 30,700 feet only.

Block Diagram Typical Test Set-up, Span Adjust
Models SSD120-(XX)N(-) -RSS

Dynamic Calibration Block Diagram

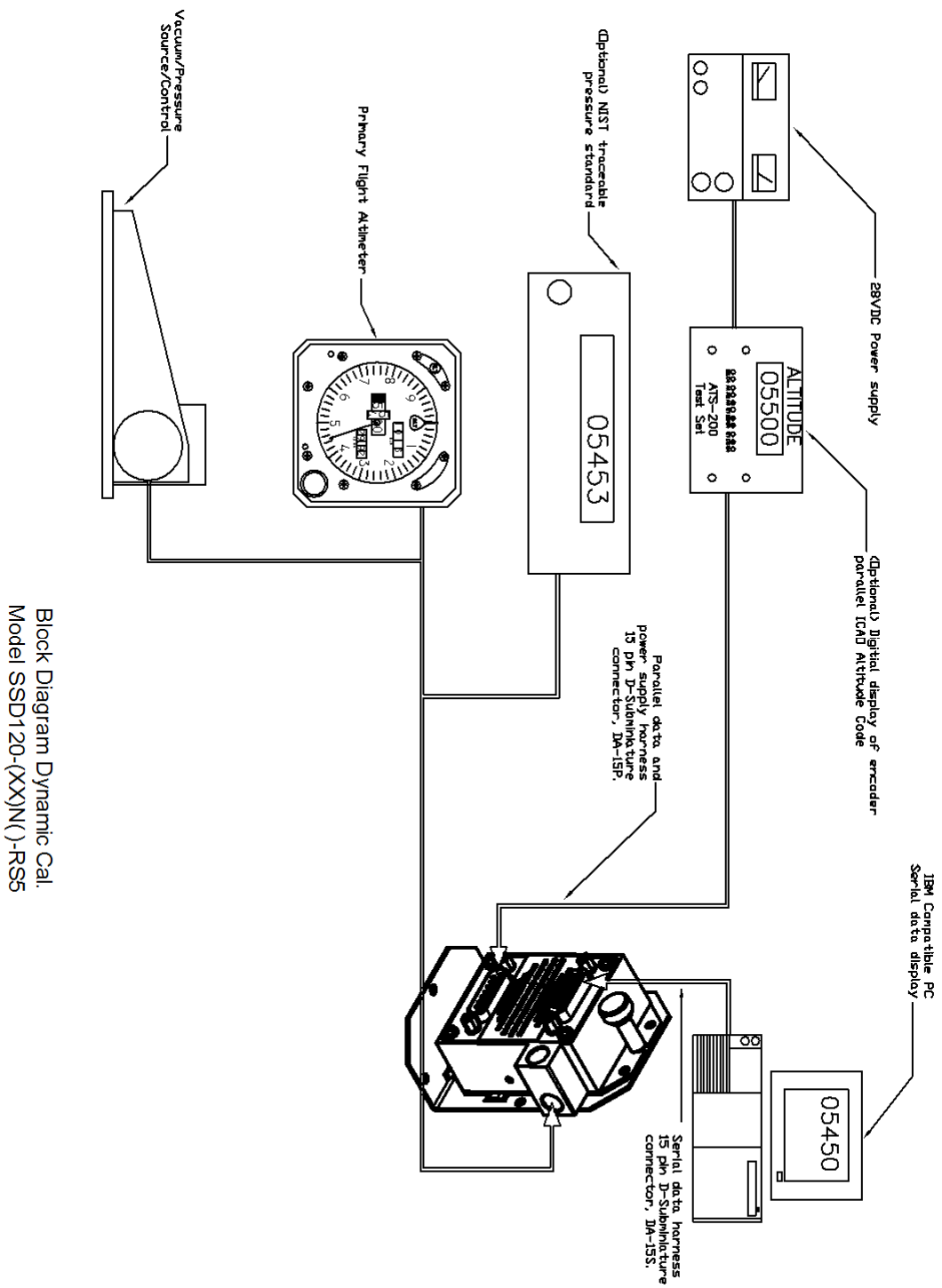

Block Diagram Dynamic Cal.
Model SSD120-(XX)N()-RSS

Figure 2 Temperature vs. Warm-up Time

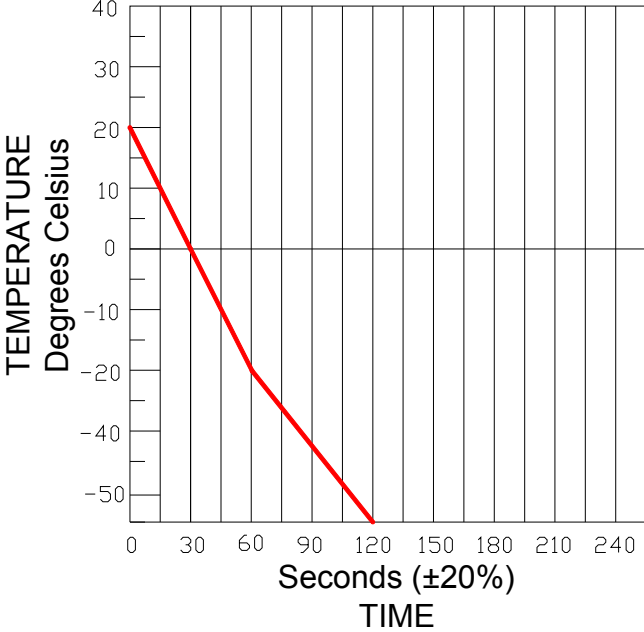

Environmental Qualification Form

Nomenclature: Altitude Digitizer

Model No.: SSD120-42N-RS5

FAA TSO-C88a and EASA ETSO-C88a

Manufacturer: Trans-Cal Industries, Inc., 16141 Cohasset St. Van Nuys, CA 91406

DO-160E Tested: October 2007

Conditions	Section	Description of Tests Conducted
Temp. and Altitude	§4.0	Tested to Category D1.
Low Temperature	§4.5.1	No cooling required.
High Temperature	§4.5.2 & 4.5.3	
In-Flight Loss of Cooling	§4.5.4	
Altitude	§4.6.1	
Decompression	§4.6.2	
Overpressure	§4.6.3	
Temp. Variation	§5.0	Tested to Category B.
Humidity	§6.0	Tested to Category A.
Operational Shock and Crash Safety	§7.0	Tested to Category B.
Vibration	§8.0	Tested to Category S Fixed Wing Zone 1, 2, 3 & 5 Curve M and Tested to Category U Helicopter Zone 1 & 2 Curve F & F1.
Explosive Atmosphere	§9.0	Identified as Category X, no test performed.
Waterproofness	§10.0	Identified as Category X, no test performed.
Fluids Susceptibility	§11.0	Identified as Category X, no test performed.
Sand and Dust	§12.0	Identified as Category X, no test performed.
Fungus Resistance	§13.0	Identified as Category X, no test performed.
Salt Spray	§14.0	Identified as Category X, no test performed.
Magnetic Effect	§15.0	Tested to Category Z.
Power Input	§16.0	Tested to Category B.
Voltage Spike	§17.0	Tested to Category B.
Audio Frequency Conducted Susceptibility – Power Inputs	§18.0	Tested to Category B.
Induced Signal Susceptibility	§19.0	Tested to Category BC.
RF Susceptibility (Radiated and Conducted)	§20.0	Tested to Category T for Radiated Susceptibility, and Category T for Conducted Susceptibility.
Emission of RF	§21.0	Tested to Category B.
Lightning Induced Transient Susceptibility	§22.0	Identified as Category X, no test performed.
Lightning Direct Effects	§23.0	Identified as Category X, no test performed.
Icing	§24.0	Identified as Category X, no test performed.
Electrostatic Discharge	§25.0	Tested to Category A.
Fire, Flammability	§26.0	Identified as Category X, no test performed.

Remarks:

During power input tests, the device was subjected to subparagraph 16.6.1.4b, requirement for devices with digital circuits.

Part Number Builder

SSD120-XX X X X-XXXX

Max. Operating Altitude (ft.) Dash Number	
30,000	-30
35,000	-35
42,000	-42
50,000	-50
62,000	-62
65,000	-65
80,000	-80
85,000	-85
100,000	-100

Model Nomenclature	
Encoder/Digitizer (Discontinued)	A
2" Dia. Module	M
Servo Module	SM
Nano Encoder Series	N

Operating Environment	
Standard -20° to +70°C	Blank
Extended -55° to +70°C	E
Extended Hermetic -55° to +70°C	EH

Static Port Connection	
Female 1/8-27NPT	Blank
.125" Dia Swivel	1

Additional Ports/Features	
Dual RS232 Ports	-RS232
Dual RS232 Ports and One RS485 Port	-RS
Dual RS232 Ports with 1' resolution data on TxD2 and one RS485 Port	-RS1
Five RS232 ports	-RS5
Serial Data Repeater	-SDR

Model Number Example: SSD120-30NE-RS232
 Solid State Altitude Digitizer -1000 to +30,000 ft., Nano Style, Extended Temperature Range, 1/8-27NPT Female Static Port, Dual RS232 Ports.

Manufacturer Direct Warranty
Do Not Return to Place of Purchase

Trans-Cal Industries warrants each Model SSD120-(XX)N()-RS5 Solid State altitude digitizer to be free of defects in workmanship and materials for a period of 42 months after purchase. **Do NOT send this unit to a distributor or retailer for repair.** Contact the factory directly if you experience problems (818) 787-1221.

This warranty applies to the original purchaser of the instrument. Trans-Cal's obligation under this warranty is limited to repairing or replacing any unit returned to Trans-Cal during the life of this warranty provided:

- (1) The defective unit is returned to Trans-Cal, **transportation pre-paid.**
- (2) Prior approval is obtained from Trans-Cal.
- (3) The unit has not been damaged by misuse, neglect, improper operation, accident, alteration or improper installation.

Trans-Cal **DOES NOT** reimburse labor costs on warranty repairs. Trans-Cal Industries will be the sole judge as to the cause of the malfunction and wherein the responsibility lies. No other obligation or liability is expressed or implied.

For the above warranty to become effective, the attached registration card **must** be completed and returned to Trans-Cal Industries, properly filled out and signed by the dealer selling or installing this equipment.

Mail to: Trans-Cal Ind., Inc., 16141 Cohasset St., Van Nuys, CA 91406

✂----- cut here -----

MODEL: SSD120-()N()-RS5 SERIAL NO: RS5-_____

AIRCRAFT:_____ NUMBER:_____

OWNER:_____

ADDRESS:_____

CITY:_____ STATE:_____ ZIP:_____

DEALER:_____

INSTALLED BY:_____

LICENSE NO:_____

INSTALLATION DATE:_____

I hereby certify the above instrument was installed in accordance with the instructions of Trans-Cal Industries, and the installation was done to industry standards. I further certify the instrument was properly working on the above date.

SIGNED:_____

PRINT NAME:_____