

Indigenous & Imported  
(Revision - 01)



**Electronics Division, Bangalore**

# **BHEL - EDN**

## **TENDER DOCUMENTS**

**COVERING, COMMERCIAL TERMS  
& CONDITIONS & ANNEXURES**

**FOR RFQ. NO. : PKN0000031 DATED 23.12.2013**

**DUE DATE : 24.01.2014**



**Bharat Heavy Electricals Ltd.,**  
(A Government of India undertaking)  
**Electronics Division**

PB No. 2606 , Mysore Road Bangalore , 560026 INDIA

Page 1 of 1

Fax : +91 80 26989217

☎ : +91 80 26998179

+91 80 26998669

+91 80 26998901

M/s.

Date: 23.12.2013

Attn. Mr/Ms.

**Sub: Receipt of Tender Enquiry (RFQ) No.: PKN0000031 DATED 23.12.2013.**  
**with tender specifications for: ANALYSER FOR STEAM & WATER ANALYSIS SYSTEM.**  
**Project / Destination : As per Special Conditions of Cotntract (SCC).**  
**Due Date for submission of Offer: 24.01.2014.**

We are forwarding herewith our Enquiry (Request for Quotation) referred above along with following tender documents:

1. Enquiry header complete with item description, quantity and delivery schedule.
2. Purchase specifications including PQR.
3. Instructions to bidders (4 pages).
4. Special Conditions of Contract (SCC) - 9 pages.
5. BHEL standard terms & conditions (Indigenous-11 pages & Imported - 7 pages) along with
  - a. Loading factors for non-compliance of Commercial Terms & Conditions (8 Pages) Annexure - I
  - b. Proforma for performance bank guarantee (for Indigenous-3 Pages & Imported - 2 pages) with instruction for PBG submission and with list of BHEL consortium bankers. Annexure- II, III(a), III(b) & III(C)
  - c. Guidelines for Reverse Auction procedure (wherever applicable)- 2 Pages. Annexure - IV.
  - d. List of International Airport. Annexure - V.
  - e. Procedure for High Sea Sale. Annexure - VI.
  - f. Guidelines for Agents (Annexure - VII) Please acknowledge receipt and confirm submission of complete offer within tender due date.
  - ~~g. Integrity pact agreement proforma attached (annexure - VIII)~~

--sd--  
PURCHASE EXECUTIVE



## Bharat Heavy Electricals Ltd.,

(A Government of India undertaking)

### Electronics Division

PB No. 2606 , Mysore Road Bangalore , 560026 INDIA

Fax : +91 80 26989217

☎ : +91 80 26998179

+91 80 26998669

+91 80 26998901

## INSTRUCTIONS TO BIDDERS

BHEL RFQ No.& Date: PKN0000031 DATED 23.12.2013

Due date : 24.01.2014. Project : Please Refer SCC.

Item : ANALYSER FOR STEAM & WATER ANALYSIS SYSTEM.

**BIDDER is requested to read the instructions marked as (✓) carefully and submit their quotation covering all the points:**

- ✓ Deviation to this specification/item description, If any shall be brought out clearly indicating "DEVIATION TO BHEL SPECIFICATION" without fail, as a part of technical offer.
- ✓ **Quotation shall be submitted in :**
  - THREE PART BID (First Part - Pre qualification in a sealed envelope, Second Part - Techno commercial
  - i.e. UN-PRICED offer in a sealed envelope & Third Part - Price offer in a separate sealed envelope alongwith Price Summary. All three sealed envelopes shall be again kept in a single sealed envelope. If priced offer is not submitted alongwith technical offer, offer is liable for rejection.

**Note : BIDDER shall ensure to superscribe all envelopes with RFQ number, RFQ Date, RFQ Due date, Item Description and Project clearly & boldly on each envelope. BHEL standard Commercial Terms and conditions must accompany techno-commercial offer without fail. BHEL standard commercial terms & conditions duly filled, signed & stamped only to be sent. Your standard printed commercial terms not needed and will not be accepted by BHEL.**

- ✓ **In three part bids, filled in commercial terms & conditions must accompany unpriced techno-commercial offer, failing which your offer is liable for rejection. Priced offer shall be complete in all respects indicating basic prices, applicable Taxes and Duties, Packing & forwarding charges (if applicable) and Freight & Insurance charges, etc. and compulsarily sent alongwith techno-commercial offer.**
- ✓ **In addition Bidder shall also quote for Erection & Commissioning Charges (E&C Charges), Documentation charges, Service Charges, Testing Charges (Type and Routine), Training Charges, Service tax, etc. wherever applicable. The price summary must indicate all the elements clearly, which will be considered for arriving at "Total cost to BHEL".**
- ✓ **Tender (quotation) to be dropped in the Tender Box with 3 compartments (Monday / Wednesday/ Friday) kept in our reception area with caption "CE, SC&PV, DEFENCE", before 13.00 Hrs. on due date mentioned on the RFQ (Request for quotation) Monday, Wednesday, Friday. Tenders will be opened on due date and time mentioned on the RFQ.**



**DETERMINATION OF THE “TOTAL COST TO BHEL”: (Indigenous Portion)**

*Total basic value + Packing & Forwarding charges + ExciseDuty+Education Cess+Sales Tax/VAT + Lumpsum Freight with service tax + Insurance (as per BHEL Insurance premium) + Service Tax (as applicable)+ packing&un packing at site during MRC(material receipt certificate)if any+ loading factor value on total basicmaterial value (for deviations to Commercial Terms & Conditions) = “TOTAL COST TO BHEL”.*

**Note :** *In case BHEL customer reimburse any one of the cost element like Excise duty, Sales Tax, Service Tax, Freight & Insurance charges, same will be removed for arriving at“TOTAL COST TO BHEL”, in turn the lowest bidder. However vendor has to quote for all the cost components.*

*The lowest technically & commercially acceptable offer arrived as above and meeting BHEL norms will be considered for further processing.*

**DETERMINATION OF THE “TOTAL COST TO BHEL”: (Imported Portion)**

*Total basic value in foreign currency (FCA value) + cost insurance freight + Customs duty+freight from Indian port to project destination + packing&un packing at site during MRC(material receipt certificate)if any+ loading factor value on total basic FCA value (for deviation to comercial terms & conditions) =“TOTAL COST OF BHEL”.*

**Note :** *Exchange Rate ruling on the date of tender opening (part -1) will bæconsiderd for converting foreign currency to Indian currency. Exchange rates , which is received from Bank and updated in SAP system of BHEL - EDN will be considered.*

In case PBG, Exchange rate on the date of tender opening (part-1) only will be considered for converting foreign currency to Indian currency and vice versa. Exchange ratereceived from Bank and updated in SAP system of BHEL - EDN will be considered.

As far as possible, the quotations shall be free from corrections/overwriting. Corrections if any should be initialed with your seal. Any typographical error, totalling mistakes, currency mistake, multiplication mistake, summing mistakes etc..observed in your priced bids, BHEL may consider as per existing guidelines mentioned in SCC for evaluation of the lowest quote. BIDDER shall honour the same in case Order is awarded for the said TENDER ENQUIRY / RFQ.

**RISK PURCHASE CLAUSE** :- The purchaser at his discretion may also make purchase of the materials **NOT** supplied in time at the **RISK & COST** of the supplier. Under such situation, it will be obligatory on the part of the supplier who fails to supply the goods in time to make good to BHEL any loss due to risk purchase.



BIDDER shall ensure to indicate clearly Excise duty, Education Cess, Sales Tax/VAT, Octroi, entry tax, Service Tax and freight charges as applicable, for the quoted items or services. In the absence of the clarity of these, any claim at a later date will not be entertained. Also any changes in taxes and duties after award of the contract, will not be considered except such are those, which are imposed by Govt. notification within the contractual delivery. Please note, seeking price amendments for change in Excise Duty due to crossing of Turnover limits will not be considered, under any circumstances.

Quotations with, payment terms of "Advance" or "Inland letter of credit" will not be considered. & such offer / quotation is liable for rejection commercially.

On award of contract if BIDDER seeks dilution of the ordered specification and if such deviation is acceptable to BHEL, BIDDER shall pass on mutually agreed price reduction to BHEL.

Any dispute arising out of this, shall be referred to the sole arbitration of Head of Dept. (Materials Management-CE-PR), EDN, Bangalore or any other officer nominated by him and his decision shall be final and binding on the parties. The venue of the arbitration in all cases shall be Bangalore.

All suits in respect of this lie in the court of Bangalore only.

BHEL reserves the right to RE-FLOAT/ REJECT / CANCEL this TENDER ENQUIRY (RFQ) without assigning any reason or cause thereof. Quotes received against this TENDER ENQUIRY are subject to and governed by all these terms and conditions. BHEL's decision will be final in awarding of the contract and binding.

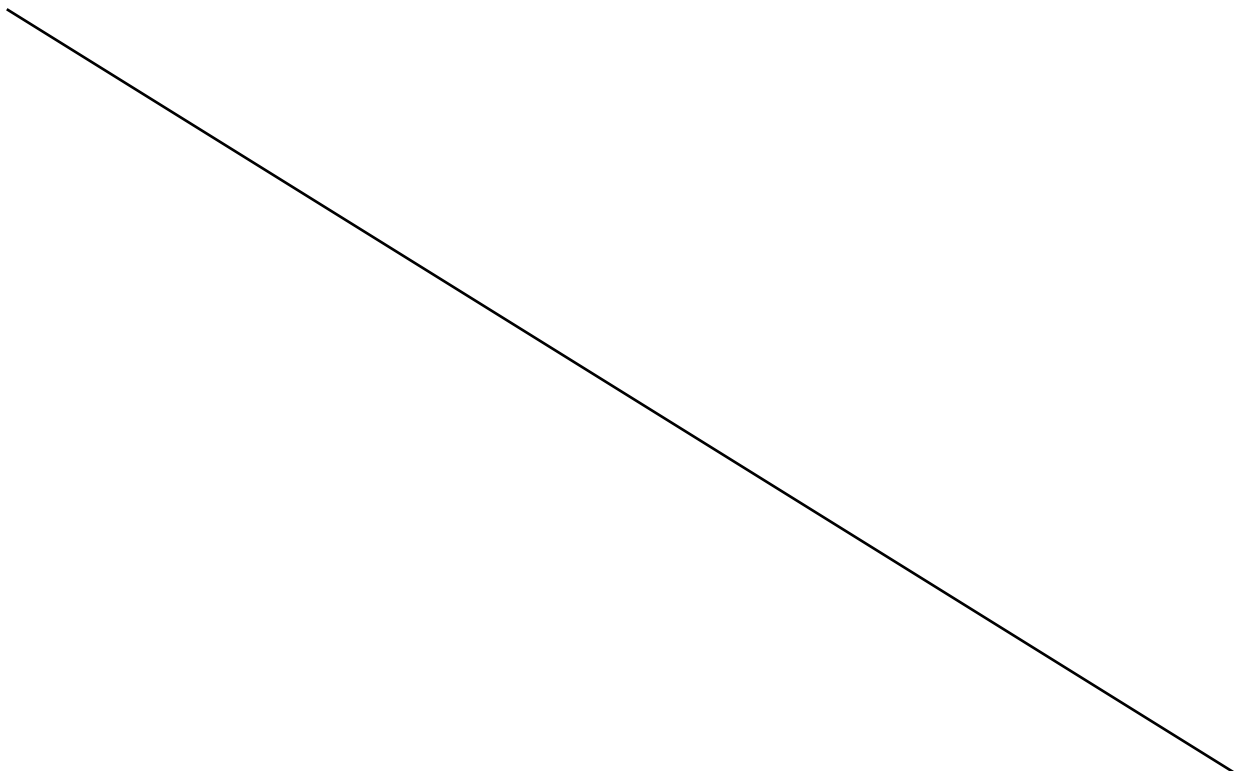

- ✓ As per our recent purchase policy, any offer received after due date and time will be treated as "Late offer" and will be rejected. Hence pl. submit offer within due date and time to avoid rejection due to late submission. It is the responsibility of vendor to submit offer in tender box within due date and time. Offer sent by fax/e-mail/courier/post etc. Which is received late will be treated as late offer and BHEL will not be responsible for late offer. In case of the "Regret to Quote" , it should be submitted in tender box within due date and time. Late offer will be returned to vendors in sealed condition.
  - ✓ Forward quotation / offer for this tender within due date and time. In case of not quoting' please send 'regret letter' which is a mandatory requirement. In case we do not receive offer / regret letter from you, we treat as 'Regret to quote' for this tender by you. In case of non receipt of "Regret Letter or Offer" it will be treated as "Regret to Quote" for this enquiry.
  - ✓ In case of rejection due to (a) pre qualification grounds, (b) commercial grounds or (c) technical grounds, the sealed price bids will be returned back to respective vendors after release of PO and receipt of order Acknowledgement from the successful bidder.
  - ✓ PBG to be sent by issuing bank directly to BHEL, Purchase department. PBG shall be from any one of the BHEL consortium banks only.
  - ✓ All bank charges to vendors account only,
  - ✓ Please quote your best, lowest, competitive, reasonable offer. Please indicate the prices in both figures & words.
  - ✓ Please sign the offers. Unsigned bids/offers may not be considered & the offer is liable for rejection.
  - ✓ Filled in BHEL standard terms and conditions should be submitted in original only. Zerox copy should not be attached.
  - ✓ In case of quotes submitted in multiple currencies, Bidder shall ensure submission of relevant filled in Indigenous/Imported BHEL standard commercial terms & conditions without fail.
  - ✓ If an indian representative/associate/liaison office quotes on behalf of a foreign based BIDDER, such representative shall furnish compulsorily the following documents :
    - i) Authorization letter to quote and negotiate on behalf of such foreign-based BIDDER.
    - ii) Undertaking from such foreign based BIDDER that such contract will be honoured and executed according to agreed scope of supply and commercial terms and conditions.
    - iii) Undertaking shall be furnished by the Indian representative stating that the co-ordination and smooth execution of the contract and settlement of shortages/damages/replacement/repair of imported scope till system is commissioned and handedover to customer will be the sole responsibility of the Indian representative/associates/agent/liaison office.
- Note : Either the Indian agent on behalf of the foreign principal or the foreign principal directly could bid in a tender but not both. Further in cases where an agent participates in a tender on behalf of one manufacturer, he will not be allowed to quote on behalf of other manufacturer alongwith first in a subsequent / parallel tender for the same item. Enclosed BHEL guidelines for regulation of agents of Foreign principals shall be complied.*
- ✓ Packing list should be provided inside each box.
  - ✓ All bank charges (inside and outside of India) are to vendors account only.
  - ✓ Customs clearance, customs duty payment will be to BHEL account after the consignment is received at Indian Airport.

**PURCHASE EXECUTIVE**



**Electronics Division, Bangalore**

**BHEL STANDARD COMMERCIAL TERMS AND CONDITIONS FOR INDIGENOUS SCOPE OF SUPPLY**

**RFQ. NO. & DATE : PKN0000031 DATED 23.12.2013**

| SL. NO. | TERMS                                            | BHEL ACCEPTABLE TERM                                                                                                                                                                                                                                                                                                                                                                                                                                                                                                                                                                                                                                                                                                                                                                                                                                | BIDDER'S CONFIRMATION                       | DEVIATION IF ANY |
|---------|--------------------------------------------------|-----------------------------------------------------------------------------------------------------------------------------------------------------------------------------------------------------------------------------------------------------------------------------------------------------------------------------------------------------------------------------------------------------------------------------------------------------------------------------------------------------------------------------------------------------------------------------------------------------------------------------------------------------------------------------------------------------------------------------------------------------------------------------------------------------------------------------------------------------|---------------------------------------------|------------------|
| 01      | <b>PRICE BASIS</b>                               | Firm i.e., from the date of PO to completion of supply if E&C is not applicable. If E&C is in supplier's scope, then the prices shall remain Firm till commissioning & handing-over of the complete system.<br><br><b>(PVC clause not acceptable).</b>                                                                                                                                                                                                                                                                                                                                                                                                                                                                                                                                                                                              | <b>AGREE</b>                                |                  |
| 02      | <b>VALIDITY</b>                                  | Valid upto 8 weeks from the date of opening of price Bid <b>(not technical bid), /date of Reverse Auction.</b>                                                                                                                                                                                                                                                                                                                                                                                                                                                                                                                                                                                                                                                                                                                                      | <b>AGREE</b>                                |                  |
| 03      | <b>TERMS OF DELIVERY</b>                         | Ex works (including Packing & Forwarding charges but excluding Taxes and Duties). Packing shall be roadworthy, best suited for multiple transshipments and to take care of transit damages.<br><br><b>Indicate Station of despatch :</b><br><b>Indicate place of manufacturing:</b><br><b>Indicate type &amp; method of packing being adopted:</b>                                                                                                                                                                                                                                                                                                                                                                                                                                                                                                  | <b>AGREE</b><br><br>_____<br>_____<br>_____ |                  |
| 04      | <b>DESTINATION</b>                               | Items are for direct despatch to BHEL's customer site located at : as per SCC,<br>Road Permit if applicable will be issued by BHEL alongwith Despatch Clearance.<br><br><b>Hence, vendor may take a special note to</b><br><b>indicate whether Central Sales Tax or Local</b><br><b>State Sales Tax or VAT will be applicable.</b>                                                                                                                                                                                                                                                                                                                                                                                                                                                                                                                  | <b>AGREE</b>                                |                  |
| 05      | <b>DOCUMENTS</b><br><br>(Pl. see loading Factor) | <b>Along with quotation :</b> As called in purchase specification shall be furnished alongwith un-priced bid.<br><br>If not called in Purchase Specification then vendor shall submit two sets of Original catalogues, Data sheets, Bill of materials, Dimensional drawings, mounting details and any other relevant documents with un-priced bid.<br><br><b>After issue of PO:</b> As called in Purchase specification for the complete scope of supply within two weeks on receipt of PO for BHEL/ customer/consultant approval.<br><br>If not called in Purchase Specification then vendor shall submit two sets of Drawings, Bill of materials, data sheets, Catalogues, Quality plan, Test procedure and Type Test Report for the complete scope of supply within <b>Two weeks</b> on receipt of PO for BHEL / Customer / Consultant approval. | <b>AGREE</b>                                |                  |



RFQ No.: PKN0000031 DATED 23.12.2013

**Electronics Division, Bangalore****BHEL STANDARD COMMERCIAL TERMS AND CONDITIONS FOR INDIGENOUS SCOPE OF SUPPLY**

| SL. NO. | TERMS                                                                                                        | BHEL ACCEPTABLE TERM                                                                                                                                                                                                                                                                                                                                                                                                                                                                                                                                                                                          | BIDDER'S CONFIRMATION                                                                                                                                            | DEVIATION IF ANY |
|---------|--------------------------------------------------------------------------------------------------------------|---------------------------------------------------------------------------------------------------------------------------------------------------------------------------------------------------------------------------------------------------------------------------------------------------------------------------------------------------------------------------------------------------------------------------------------------------------------------------------------------------------------------------------------------------------------------------------------------------------------|------------------------------------------------------------------------------------------------------------------------------------------------------------------|------------------|
| 06      | <b>PENALTY (FOR DELAY IN SUBMISSION OF DOCUMENTS FOR BHEL / CUSTOMER APPROVAL) : (PI see loading factor)</b> | <p>In the event of delay in submission of complete set of documents (including soft copy wherever applicable) in required sets beyond 2 weeks from receipt of Purchase order (vendor to confirm date of receipt of PO in writing), Penalty @ 2% (two percent) per week but limited to a max. of 10% (Ten percent) value of the basic material value will be applicable.</p> <p>Penalty if applicable shall be deducted at the time of settlement of 75% payment.</p> <p>If penalty is applicable for duration of less than a week penalty @ 2% (two percent) of the basic material value will be charged.</p> | <b>AGREE</b>                                                                                                                                                     |                  |
| 07      | <b>EXCISE DUTY &amp; EDUCATION CESS</b>                                                                      | <p>To confirm whether applicable. If applicable, indicate prevailing rate of Excise duty and maximum rate of Excise duty (against proof of Excise Invoice) However, for calculation purpose and arriving at "<b>Total cost to BHEL</b>" maximum rate of Excise Duty will be considered. In case Excise Duty remain FIRM throughout the contract, the same shall be specifically indicated. Otherwise, maximum Excise duty will be considered for arriving at lowest bidder. However, reimbursement of Excise Duty shall be at actuals against proof of Excise Invoice only.</p>                               | <p><b>AGREE</b></p> <p><b>Excise Duty rate at present</b><br/>.....%</p> <p><b>Maximum rate of Excise duty</b><br/>.....%</p> <p><b>Education Cess.....%</b></p> |                  |

BHEL-EDN

VENDOR'S SIGNATURE WITH SEAL





RFQ No.: PKN0000031 DATED 23.12.2013

## Electronics Division, Bangalore

## BHEL STANDARD COMMERCIAL TERMS AND CONDITIONS FOR INDIGENOUS SCOPE OF SUPPLY

| SL. NO.        | TERMS                                                                                                                           | BHEL ACCEPTABLE TERM                                                                                                                                                                                                                                                                                                                                                                                                                                                                                                                                                                                                                                                                                                                                                                                                                                    | BIDDER'S CONFIRMATION                                                                                                                                                 | DEVIATION IF ANY |
|----------------|---------------------------------------------------------------------------------------------------------------------------------|---------------------------------------------------------------------------------------------------------------------------------------------------------------------------------------------------------------------------------------------------------------------------------------------------------------------------------------------------------------------------------------------------------------------------------------------------------------------------------------------------------------------------------------------------------------------------------------------------------------------------------------------------------------------------------------------------------------------------------------------------------------------------------------------------------------------------------------------------------|-----------------------------------------------------------------------------------------------------------------------------------------------------------------------|------------------|
| 08             | <b>IN CASE PROJECT IS DEEMED EXPORT, MEGA AND NON MEGA AND WON AGAINST INTERNATIONAL COMPITITIVE BIDDING (ICB)</b>              | <p>In case vendor is importing any raw materials / components for the enquired item, same are eligible for Zero Customs duty. As per para 8.7 of Hand Book of procedures of EXIM policy, BHEL will part the import licence with the vendors to obtain import licence by themselves and custom clear the raw materials/ components by availing zero customs duty. Hence, please furnish list of raw materials / components to be imported by you with Quantity and CIF value (for which BHEL has to share import licence). The benefit due to the above shall be passed on to BHEL and confirmed in the quotation.</p> <p>If there are no imported raw materials/components, same shall be confirmed in the offer.<br/>Excise duty is fully exempted. Necessary documents for availing Excise duty Exemption by suppliers will be furnished by BHEL.</p> | <p>Agreed</p> <p><b>Furnished</b></p> <p><b>Yes, benefit passed-on to BHEL in the quotation.</b></p> <p><b>We, confirm that there are no imported components.</b></p> |                  |
| <del>09.</del> | <del><b>IN-CASE PROJECT IS DEEMED EXPORT, WON AGAINST INTERNATIONAL COMPITITIVE BIDDING (ICB) BUT NOT A MEGA PROJECT.</b></del> | <p><del>The project is eligible for claiming Terminal Excise duty benefit from DGFT as per present EXIM policy. PL Confirm that you will submit (original)</del></p> <p><del>a) Disclaimer Certificate.</del></p> <p><del>b) Copy of Excise Invoice attested by Suptd of Central excise authorities with signature &amp; seal, in Blue ink to enable BHEL to claim terminal Excise duty benefit from DGFT.</del></p>                                                                                                                                                                                                                                                                                                                                                                                                                                    | <del><b>CONFIRMED</b></del>                                                                                                                                           |                  |
| 10             | <b>SALES TAX</b>                                                                                                                | <p>To confirm whether applicable. If applicable, indicate current rate of sales tax against form "C"<br/>For issue of form "C", vendor has to furnish "E1/E2" form</p> <p><b>Please confirm that "E1/E2 Sale form" will be submitted</b></p> <p>For physical export project, Sales Tax is exempted against submission of necessary documents by BHEL. However, vendor to indicate rate of Sales Tax applicable (against form 'C/37') for the item enquired.</p>                                                                                                                                                                                                                                                                                                                                                                                         | <p><b>AGREE</b></p> <p><b>Sales Tax rate at present.....%</b></p> <p><b>CONFIRMED</b></p>                                                                             |                  |

BHEL-EDN

VENDOR'S SIGNATURE WITH SEAL



RFQ No.: PKN0000031 DATED 23.12.2013

**Electronics Division, Bangalore****BHEL STANDARD COMMERCIAL TERMS AND CONDITIONS FOR INDIGENOUS SCOPE OF SUPPLY**

| SL. NO. | TERMS                                   | BHEL ACCEPTABLE TERM                                                                                                                                                                                                                                                                                                                                                                                                                                         | BIDDER'S CONFIRMATION                                                                        | DEVIATION IF ANY |
|---------|-----------------------------------------|--------------------------------------------------------------------------------------------------------------------------------------------------------------------------------------------------------------------------------------------------------------------------------------------------------------------------------------------------------------------------------------------------------------------------------------------------------------|----------------------------------------------------------------------------------------------|------------------|
|         |                                         | <p>Note : Please see the state indicated above SI. No. 4 (Page 1 of 11) to which materials to be despatched before indicating rate of Sales Tax.</p> <p>Furnish following :</p> <p>CST Regn No.</p> <p>LST Regn No.</p> <p>TIN No.</p>                                                                                                                                                                                                                       | INDICATED                                                                                    |                  |
| 11      | VALUE ADDED TAX                         | <p>Since it is inter-state movement of goods, VAT is not applicable. Only CST against form C is applicable.</p> <p>OR</p> <p>Both are in the same State, VAT is applicable please indicate VAT applicable @ _____ %</p>                                                                                                                                                                                                                                      | <p>AGREE</p> <p>QUOTED</p>                                                                   |                  |
| 12      | OCTROI                                  | To confirm whether applicable, if applicable indicate current rate of Octroi _____ %                                                                                                                                                                                                                                                                                                                                                                         | AGREE                                                                                        |                  |
| 13      | SERVICE TAX ON E & C & TRAINING CHARGES | <p>To confirm whether applicable, if applicable indicate current rate of Service Tax _____ %</p> <p><i>Furnish following :</i></p> <p><i>Service Tax Regn. No.</i></p> <p><i>Confirmation that Service Tax register is maintained.</i></p>                                                                                                                                                                                                                   | <p>AGREE</p> <p>FURNISHED CONFIRMED</p>                                                      |                  |
| 14      | FREIGHT CHARGES                         | <p>Freight charges shall be to vendor's account. Please indicate Freight charges separately as lumpsum charges in priced offer, Plus service tax if any.</p> <p>Vendor's offer will be evaluated on "Total cost basis" including freight charges.</p> <p>Vendor shall book the consignment through their approved Road carriers on "Freight pre-paid" door delivery consignee copy attached basis, and freight charges to be claimed from BHEL through a</p> | <p>Agreed and quoted in lumpsum with Service Tax in price bid</p> <p>Service Tax _____ %</p> |                  |

BHEL-EDN

VENDOR'S SIGNATURE WITH SEAL



RFQ No.: PKN0000031 DATED 23.12.2013

**Electronics Division, Bangalore****BHEL STANDARD COMMERCIAL TERMS AND CONDITIONS FOR INDIGENOUS SCOPE OF SUPPLY**

| SL. NO. | TERMS                                                       | BHEL ACCEPTABLE TERM                                                                                                                                                                                                                                                                                                                                                                                                                                                                                                                                                                                                                                                                                                   | BIDDER'S CONFIRMATION | DEVIATION IF ANY |
|---------|-------------------------------------------------------------|------------------------------------------------------------------------------------------------------------------------------------------------------------------------------------------------------------------------------------------------------------------------------------------------------------------------------------------------------------------------------------------------------------------------------------------------------------------------------------------------------------------------------------------------------------------------------------------------------------------------------------------------------------------------------------------------------------------------|-----------------------|------------------|
|         |                                                             | <p>separate Invoice against proof of L/R copy and original money receipt and transporter bill to vendor received from the Transporter. The freight charges will be reimbursed to vendor, limited to freight quoted by the vendor in his offer or actual payment made to Transporter, whichever is <b>lower</b>.</p> <p>Vendor shall furnish following details alongwith Freight payment Bill :</p> <ul style="list-style-type: none"> <li>a) Net weight</li> <li>b) Gross weight</li> <li>c) Volume of each package</li> <li>d) No. of packages</li> <li>e) Loose items, if any</li> <li>f) Distance from vendor's works to destination.</li> </ul> <p>This is needed for justifying freight amount quoted by you.</p> |                       |                  |
| 15      | <p><b>TRANSIT INSURANCE</b></p> <p><b>(To BHEL A/c)</b></p> | <p>By BHEL/BHEL power sector/Customer. Insurance Agency will be indicated in despatch clearance letter/fax /E-mail issued by BHEL. Immediately after despatch of material the vendor should intimate by fax/e-mail/ courier to the insurance agency directly for covering insurance and a copy of such intimation sent to insurance agency Indicated in the despatch instructions directly by vendor should be given to BHEL alongwith despatch documents for payment</p> <p><u>NOTE</u> : BHEL will not send insurance intimations to insurance company on your behalf. Hence it is your responsibility to intimate to insurance agency.</p>                                                                          | <b>AGREE</b>          |                  |

BHEL-EDN

VENDOR'S SIGNATURE WITH SEAL



RFQ No.: PKN0000031 DATED 23.12.2013

## Electronics Division, Bangalore

## BHEL STANDARD COMMERCIAL TERMS AND CONDITIONS FOR INDIGENOUS SCOPE OF SUPPLY

| SL. NO. | TERMS                                                                                                 | BHEL ACCEPTABLE TERM                                                                                                                                                                                                                                                                                                                                                                                                                                                                                                                                                                                                                                                                                                                                                                                                                                                                                                                                                                                                                                                                                                                                                                                                                                                                                                                                                                                                                                                                                                                                                                                                                                                                                                                                           | BIDDER'S CONFIRMATION | DEVIATION IF ANY |
|---------|-------------------------------------------------------------------------------------------------------|----------------------------------------------------------------------------------------------------------------------------------------------------------------------------------------------------------------------------------------------------------------------------------------------------------------------------------------------------------------------------------------------------------------------------------------------------------------------------------------------------------------------------------------------------------------------------------------------------------------------------------------------------------------------------------------------------------------------------------------------------------------------------------------------------------------------------------------------------------------------------------------------------------------------------------------------------------------------------------------------------------------------------------------------------------------------------------------------------------------------------------------------------------------------------------------------------------------------------------------------------------------------------------------------------------------------------------------------------------------------------------------------------------------------------------------------------------------------------------------------------------------------------------------------------------------------------------------------------------------------------------------------------------------------------------------------------------------------------------------------------------------|-----------------------|------------------|
| 16      | <b>DELIVERY PERIOD</b><br><br>(Pl. see loading Factor)                                                | For Sagardighi 2 units: within 8 weeks from document approval or mfg clns by BHEL whichever is earlier .For balance projects plz ref SCC.                                                                                                                                                                                                                                                                                                                                                                                                                                                                                                                                                                                                                                                                                                                                                                                                                                                                                                                                                                                                                                                                                                                                                                                                                                                                                                                                                                                                                                                                                                                                                                                                                      | <b>AGREE</b>          |                  |
| 17      | <b>WARRANTY</b><br>(Pl. see loading Factor)                                                           | 30 months from the date of despatch or 24 months from the date of commissioning whichever is earlier.                                                                                                                                                                                                                                                                                                                                                                                                                                                                                                                                                                                                                                                                                                                                                                                                                                                                                                                                                                                                                                                                                                                                                                                                                                                                                                                                                                                                                                                                                                                                                                                                                                                          | <b>AGREE</b>          |                  |
| 18      | <b>TERMS OF PAYMENT (FOR MATERIAL SUPPLY &amp; TYPE TEST CHARGES)</b><br><br>(Pl. see loading Factor) | <p>a) 75 % basic + 100% Taxes , Duties and freight charges with 45 days credit from the date of receipt of complete set of original despatch documents . Original Performance Bank Guarantee to be sent by issuing bank directly to BHEL and PBG is mandatory.</p> <p>Original consignee copy of L/R (lorry receipt) shall accompany the goods.</p> <p><del>Note : In case PBG is not furnished only 65 % payment will be released against 75 % claim without the consent of Vendor.</del></p> <p><del>This 10% basic amount withhold amount towards PBG will be paid against submission of supplementary invoice &amp; Original PBG (or) against supplementary invoice without PBG after 36 months from the date of despatch provided BHEL Commercial Dept. confirms that there is no site issue pending for this P.O. items supplied by you.</del></p> <p>b) Balance 10% basic amount with 30 days credit from receipt of materials at site against material receipt certificate (MRC). i.e. acknowledgement/seal on backside of the LR for having received the consignment by consignee and proof of supply of O&amp;M manuals in requisite sets, against a supplementary Invoice alongwith MOM copy of site .</p> <p>c) Balance 15% basic amount with 30 days credit on completion of Erection &amp; commissioning work on pro-rata basis against supplementary Invoice with "Proof of completion of E&amp;C" (like MOM, Site protocol, Job completion certificate), signed by BHEL site office or Customer and your representative.</p> <p><b>Note : No advance will be paid and no inland L/C will be accepted. Payment thro' bank may not be acceptable to BHEL (as all payments or made thro' EFT only) Hence please avoid payment thro' bank.</b></p> | <b>AGREE</b>          |                  |

BHEL-EDN

VENDOR'S SIGNATURE WITH SEAL



RFQ No.: PKN0000031 DATED 23.12.2013

**Electronics Division, Bangalore****BHEL STANDARD COMMERCIAL TERMS AND CONDITIONS FOR INDIGENOUS SCOPE OF SUPPLY**

| SL. NO. | TERMS                                                                 | BHEL ACCEPTABLE TERM                                                                                                                                                                                                                                                                                                                                                                                                                                                                                                                                                                                                                                                                                                                                                                                                                                           | BIDDER'S CONFIRMATION | DEVIATION IF ANY |
|---------|-----------------------------------------------------------------------|----------------------------------------------------------------------------------------------------------------------------------------------------------------------------------------------------------------------------------------------------------------------------------------------------------------------------------------------------------------------------------------------------------------------------------------------------------------------------------------------------------------------------------------------------------------------------------------------------------------------------------------------------------------------------------------------------------------------------------------------------------------------------------------------------------------------------------------------------------------|-----------------------|------------------|
|         | <b>TERMS OF PAYMENT (FOR E&amp;C)</b>                                 | 100% Lumpsum E&C / Installation charges with Service Tax (if applicable) shall be paid with 30 days credit on completion of Erection & commissioning work on pro-rata basis against submission of "Proof of completion of E&C"(like MOM, Site protocol, Job completion certificate), signed by BHEL site office or Customer and vendors' representative.<br>Separate Invoice shall be submitted for charges towards E&C payment.                                                                                                                                                                                                                                                                                                                                                                                                                               | <b>AGREE</b>          |                  |
|         | <b>TERMS OF PAYMENT (FOR TRAINING)</b>                                | 100% payable with 30 days credit on completion of Training. Separate invoice shall be submitted for Training charges                                                                                                                                                                                                                                                                                                                                                                                                                                                                                                                                                                                                                                                                                                                                           | <b>AGREE</b>          |                  |
|         | <b>TERMS OF PAYMENT (FOR ENGINEERING &amp; DOCUMENTATION CHARGES)</b> | 100% with 30 days credit on approval of final documents.<br>Separate invoice to be submitted for Engineering & documentation charges                                                                                                                                                                                                                                                                                                                                                                                                                                                                                                                                                                                                                                                                                                                           | <b>AGREE</b>          |                  |
| 19      | <b>GENERAL</b>                                                        | BHEL has discontinued cheque payments and all payments will be through Electronic fund Transfer (EFT) only. Please provide necessary details (if you have not furnished earlier) in the BHEL's standard format.                                                                                                                                                                                                                                                                                                                                                                                                                                                                                                                                                                                                                                                | <b>AGREE</b>          |                  |
| 20      | <b>SHORTAGES / DAMAGES</b>                                            | In the event of shortage/damage on receipt of goods and on opening of packages at site, all such shortages/damages shall be made good within reasonable time of such intimation and cost of such material will be reimbursed only on settlement of Insurance claim limited to insurance settled amount.                                                                                                                                                                                                                                                                                                                                                                                                                                                                                                                                                        | <b>AGREE</b>          |                  |
| 21      | <b>PENALTY</b><br>(Pl. see loading Factor)                            | In the event of delay in agreed contractual delivery, penalty @ 2 % ( two percent ) per week but limited to a max of 10% (Ten percent) value of undelivered portion (basic material cost) will be applicable.<br>Date of issue of inspection call by vendor along with test certificates / Test Reports / Certificate of Conformance / Calibration reports, as proof of completion of manufacturing will be treated as date of despatch for penalty calculation.<br><br>In the absence of furnishing such relevant above cited document as proof of completion of manufacturing alongwith inspection call, actual date of Inspection will be considered as date of despatch, and BHEL will not be responsible for delay in actual date of inspection.<br><br>Hence please issue inspection call with test certificates/ reports compulsorily to avoid penalty. | <b>AGREE</b>          |                  |

BHEL-EDN

VENDOR'S SIGNATURE WITH SEAL



RFQ No.: PKN0000031 DATED 23.12.2013

**Electronics Division, Bangalore****BHEL STANDARD COMMERCIAL TERMS AND CONDITIONS FOR INDIGENOUS SCOPE OF SUPPLY**

| SL. NO. | TERMS                                                        | BHEL ACCEPTABLE TERM                                                                                                                                                                                                                                                                                                                                                                                                                                                                                                                                                                                                                                                                                                                                                                                                                                                                                                                                                                                                                                                                                                                                                            | BIDDER'S CONFIRMATION                                         | DEVIATION IF ANY |
|---------|--------------------------------------------------------------|---------------------------------------------------------------------------------------------------------------------------------------------------------------------------------------------------------------------------------------------------------------------------------------------------------------------------------------------------------------------------------------------------------------------------------------------------------------------------------------------------------------------------------------------------------------------------------------------------------------------------------------------------------------------------------------------------------------------------------------------------------------------------------------------------------------------------------------------------------------------------------------------------------------------------------------------------------------------------------------------------------------------------------------------------------------------------------------------------------------------------------------------------------------------------------|---------------------------------------------------------------|------------------|
|         |                                                              | <p>Penalty will be applicable after 8 weeks for Sagardighi &amp; Muzafferpur and 16 weeks for other projects from the date of document approval or manufacturing clearance, whichever is earlier .For balance projects plz ref SCC.</p> <p>Penalty if applicable shall be deducted at the time of settlement of 75 % payment.</p> <p>If penalty is applicable for duration of less than a week, penalty @2 % ( two percent ) of the basic material value will be charged.</p> <p>In case of vendor availing Duty concession under duty free licence under para No. 8.7 of EXIM policy procedure, any delay in furnishing documents for this purpose by BHEL will be suitably adjusted while calculating penalty.</p>                                                                                                                                                                                                                                                                                                                                                                                                                                                            |                                                               |                  |
| 22      | <p><b>PERFORMANCE BANK GUARANTEE</b></p> <p>(Mandatory )</p> | <p>Original PBG for 10% of the basic material cost shall be furnished in the BHEL prescribed format only (Annexure-II), directly by issuing bank to BHEL for processing 75% payment.</p> <p>PBG shall be valid for 30 months + 6 months claim period from date of despatch (totally 36 months from the date of despatch)</p> <p>PBG shall be from any of the BHEL consortium Bankers as per Annexure-III(b), and banker should send PBG directly to BHEL please see instruction for PBG submission attached - Annexure - III(a)</p> <p>Please indicate the Banker name from whom PBG will Issuing bank name be furnished without fail.</p> <p>PBG proforma enclosed. <del>If PBG is not submitted as per enclosed BHEL standard proforma, i.e., PBG is submitted in Vendor's format (other than BHEL proforma) or quoted Revolving PBG, it will be treated as Vendor has not agreed for PBG clause (non-submission of PBG only) and price will be loaded as per the loading factors enclosed(Annexure - I) to arrive at " total cost to BHEL" and BHEL reserves the right to commercially reject the offer when the item enquired demands performance bank guarantee.</del></p> | <p><b>AGREE</b></p> <p><b>Issuing Bank Name indicated</b></p> |                  |

BHEL-EDN

VENDOR'S SIGNATURE WITH SEAL



RFQ No.: PKN0000031 DATED 23.12.2013

**Electronics Division, Bangalore****BHEL STANDARD COMMERCIAL TERMS AND CONDITIONS FOR INDIGENOUS SCOPE OF SUPPLY**

| SL. NO. | TERMS                     | BHEL ACCEPTABLE TERM                                                                                                                                                                                                                                                                                                                                                                                                                                                                                                                                                                    | BIDDER'S CONFIRMATION | DEVIATION IF ANY |
|---------|---------------------------|-----------------------------------------------------------------------------------------------------------------------------------------------------------------------------------------------------------------------------------------------------------------------------------------------------------------------------------------------------------------------------------------------------------------------------------------------------------------------------------------------------------------------------------------------------------------------------------------|-----------------------|------------------|
| 23      | <b>INSPECTION</b>         | <p>Prior written notice of atleast 7 days shall be given along with 2 sets of internal test certificates/COC and applicable test certificates. Materials will be inspected by BHEL-EDN-QS/CQS or M/s PDIL (BHEL authorised Inspection Agency) or Customer / Consultant or jointly by BHEL &amp; Customer / consultant.</p> <p>All tests have to be conducted as applicable in line with approved Quality plan or QA Checklist or Purchase specification and original reports shall be furnished to BHEL-EDN, Bangalore for verification/acceptance and issue of despatch clearance.</p> | <b>AGREE</b>          |                  |
| 24      | <b>MODE OF DESPATCH</b>   | By road on door delivery Consignee Copy attached basis as per BHEL despatch instructions through your approved transporters, only on receipt of despatch clearance from BHEL.                                                                                                                                                                                                                                                                                                                                                                                                           | <b>AGREE</b>          |                  |
| 25      | <b>DESPATCH DOCUMENTS</b> | <p>Complete set of despatch documents in 3 sets shall be forwarded to BHEL directly. Despatch documents include Commercial Invoice, Excise Invoice (if ED is applicable), Lorry receipt (L/R), Packing list, Warranty certificate, Insurance intimation letter, "NIL" short shipment certificate and Original Performance Bank Guarantee (Directly from issuing bank to BHEL).</p> <p>One set of Invoice, Packing list and L/R shall be faxed immediately after despatch to BHEL-EDN, Bangalore.</p>                                                                                    | <b>AGREE</b>          |                  |
| 26      | <b>O &amp; M MANUALS</b>  | As built Drawings, O & M Manuals and other approved documents in 2 sets shall be furnished immediately after despatch directly to BHEL Purchase Dept., 1 set of above shall also be sent in soft media (CD ROM). Two sets of hard copies of above shall be directly despatched to site along with the material.                                                                                                                                                                                                                                                                         | <b>AGREE</b>          |                  |

BHEL-EDN

VENDOR'S SIGNATURE WITH SEAL



RFQ No.: PKN0000031 DATED 23.12.2013

## Electronics Division, Bangalore

## BHEL STANDARD COMMERCIAL TERMS AND CONDITIONS FOR INDIGENOUS SCOPE OF SUPPLY

| SL. NO. | TERMS                                                              | BHEL ACCEPTABLE TERM                                                                                                                                                                                                                                                                                                                                                                                                                                                                                                                                                               | BIDDER'S CONFIRMATION                                     | DEVIATION IF ANY                     |
|---------|--------------------------------------------------------------------|------------------------------------------------------------------------------------------------------------------------------------------------------------------------------------------------------------------------------------------------------------------------------------------------------------------------------------------------------------------------------------------------------------------------------------------------------------------------------------------------------------------------------------------------------------------------------------|-----------------------------------------------------------|--------------------------------------|
|         |                                                                    | Note : Supply of above documents (O&M) in required No. of sets along with Despatch documents and material shall be indicated in packing list.<br>If not mentioned BHEL may insist for submission in required sets once again.                                                                                                                                                                                                                                                                                                                                                      |                                                           |                                      |
| 27      | SPLIT ORDERING                                                     | Package purchase as per details given in SCC                                                                                                                                                                                                                                                                                                                                                                                                                                                                                                                                       | AGREE                                                     |                                      |
| 28      | QUANTITY TOLERANCE                                                 | Please <del>indicate Quantity tolerance applicable in each of the line item wherever Quantity tolerance applicable for the Quoted items.</del>                                                                                                                                                                                                                                                                                                                                                                                                                                     | CONFIRMED                                                 | QUANTITY TOLERANCE .....%PER VARIETY |
| 29      | SLAB RATE                                                          | Slab rate as per SCC                                                                                                                                                                                                                                                                                                                                                                                                                                                                                                                                                               | AGREE                                                     |                                      |
| 30      | SPECIAL CLASS ( <del>EXCISE DUTY DRAW BACK FROM DGFT</del> )       | Following documents (Original) shall be submitted <del>for availing Excise duty draw back benefit from DGFT along with despatch documents to BHEL EDN, Bangalore</del><br>a) <del>Disclaimer certificate as per the proforma, which will be, sent with the PO.</del><br>b) <del>Copy of Excise Invoice duly attested by Suptd of Central Excise (signature in blue ink &amp; seal) Pl. refer enclosure to RFQ.</del>                                                                                                                                                               | AGREE                                                     |                                      |
| 31      | ERECTION & COMMISSIONING (E & C) / INSTALLATION / ASSEMBLY AT SITE | Indicate lumpsum charges (includes To & Fro Fare, Boarding, Lodging, Local Conveyance, etc.) for Supervision of Erection, Commissioning and handingover to customer. The quotation shall clearly indicate scope of work, likely duration of commissioning, pre-commissioning check list and service taxes if any to consider for arriving at total cost to BHEL.<br><br><b>Note : If E&amp;C is not quoted (wherever called for in the BHEL purchase specification) BHEL reserve the right to reject your offer.<br/>If lumpsum charges are not quoted, offer may be rejected.</b> | AGREE & CONFIRMED QUOTED IN LUMP SUM CHARGES IN PRICE BID |                                      |

BHEL-EDN

VENDOR'S SIGNATURE WITH SEAL



RFQ No.: PKN0000031 DATED 23.12.2013



## Electronics Division, Bangalore

### BHEL STANDARD COMMERCIAL TERMS AND CONDITIONS FOR INDIGENOUS SCOPE OF SUPPLY

| SL. NO. | TERMS                                                           | BHEL ACCEPTABLE TERM                                                                                                                                                                                                                                                                                                                                                                                                                                                                                                                                                                                                                                                                                                                                                                                                                                                                                                                                                                  | BIDDER'S CONFIRMATION      | DEVIATION IF ANY |
|---------|-----------------------------------------------------------------|---------------------------------------------------------------------------------------------------------------------------------------------------------------------------------------------------------------------------------------------------------------------------------------------------------------------------------------------------------------------------------------------------------------------------------------------------------------------------------------------------------------------------------------------------------------------------------------------------------------------------------------------------------------------------------------------------------------------------------------------------------------------------------------------------------------------------------------------------------------------------------------------------------------------------------------------------------------------------------------|----------------------------|------------------|
| 32      | <b>REVERSE AUCTION</b>                                          | BHEL reserves the right to go for Reverse Auction (RA) instead of opening the sealed envelope price bid, submitted by the bidder. This will be decided after techno-commercial evaluation. All bidders to give their acceptance for participation in RA. Non-acceptance to participate in RA may result in non-consideration of their bids, in case BHEL decides to go for RA. In case BHEL decides to go for Reverse Auction, only those bidders who have given their acceptance to participate in RA will be allowed to participate in the Reverse Auction. Those bidders who have given their acceptance to participate in Reverse Auction will have to necessarily submit „online sealed bid“ in the Reverse Auction. Non-submission of "online sealed bid" by the bidder will be considered as tampering of the tender process and will invite action by BHEL as per extant guidelines in vogue." Information and General Terms and Conditions governing RA given Annexure - IV. | <b>AGREE</b>               |                  |
| 33      | <del><b>SPECIAL CLAUSE APPLICABLE FOR EXPORT JOB ONLY</b></del> | <del>Article packed with raw/solid wood packing material</del><br><del>CLAUSE should be treated as per ISPM 15</del><br><del>(fumigation) and APPLICABLE accomplished by</del><br><del>Phytosanitary/Fumigation certificate.</del><br><del>DESTINATION SEA PORT / AIR PORT IN</del><br><del>INDIA...</del>                                                                                                                                                                                                                                                                                                                                                                                                                                                                                                                                                                                                                                                                            | <b>AGREE</b>               |                  |
| 34      | <b>EXTENDED WARRANTY</b>                                        | Please indicate charges if any, in % of Total Basic material value for extended warranty per annum, if BHEL decides to have at later stage.<br><br><b>Please note, extended warranty charges will not be considered for evaluation of lowest bidder.</b>                                                                                                                                                                                                                                                                                                                                                                                                                                                                                                                                                                                                                                                                                                                              | <b>AGREE</b><br><br>-----% |                  |

THE ABOVE FILLED-IN AND SIGNED DOCUMENT SHALL BE FURNISHED AS PART OF UN-PRICED CUM - TECHNICAL BID WITHOUT FAIL ( IN ORIGINAL).

NOTE : LOWEST BIDDER WILL BE DECIDED BASED ON THE "TOTAL COST TO BHEL" BASIS INCLUDING LOADING FACTORS (FOR DEVIATIONS TO BHEL STANDARD COMMERCIAL TERMS & CONDITIONS).

BHEL-EDN

VENDOR'S SIGNATURE WITH SEAL



RFQ No.: PKN0000031 DATED 23.12.2013

**Electronics Division, Bangalore****BHEL STANDARD COMMERCIAL TERMS AND CONDITIONS FOR IMPORTED SCOPE OF SUPPLY**

| SL. NO. | TERMS                                                                            | BHEL ACCEPTABLE TERM                                                                                                                                                                                                                                                                                                                                                                                                                                             | BIDDER'S CONFIRMATION | DEVIATION IF ANY |
|---------|----------------------------------------------------------------------------------|------------------------------------------------------------------------------------------------------------------------------------------------------------------------------------------------------------------------------------------------------------------------------------------------------------------------------------------------------------------------------------------------------------------------------------------------------------------|-----------------------|------------------|
| 01      | COUNTRY OF ORIGIN & PLACE OF MANUFACTURING                                       | PL INDICATE FOR THE TOTAL SCOPE OF SUPPLY<br><b>COUNTRY OF ORIGIN</b><br><br><b>PLACE OF MANUFACTURING (TOTAL PACKAGES)</b>                                                                                                                                                                                                                                                                                                                                      | FURNISHED             |                  |
| 02      | NAME & ADDRESS OF THE BIDDER :<br>A) IN PURCHASE ORDER<br>B) IN LETTER OF CREDIT |                                                                                                                                                                                                                                                                                                                                                                                                                                                                  | FURNISHED             |                  |
| 03      | NAME ADDRESS OF FOREIGN BANK ACCOUNT NO. & SWIFT CODE                            |                                                                                                                                                                                                                                                                                                                                                                                                                                                                  | FURNISHED             |                  |
| 04      | PRICE BASIS & CURRENCY                                                           | Firm i.e., from the PO date to completion of supply<br><b>(Price variation Clause not acceptable).</b><br>Currency :                                                                                                                                                                                                                                                                                                                                             | AGREE                 |                  |
| 05      | VALIDITY                                                                         | Valid up to 8 weeks from the date of opening of price Bid <b>(not technical bid).</b>                                                                                                                                                                                                                                                                                                                                                                            | AGREE                 |                  |
| 06.     | TERMS OF DELIVERY                                                                | Price offered shall be for goods packed and delivered F. C.A. (named International Airport/ Seaport) including Packing, Forwarding, Handling, Ancillary charges like processing of Sight Draft , negotiation of Bank Documents, Export declaration, Certificate of Origin, etc. Packing shall be Airworthy, best suited for transshipment and to take care of transit damages.<br><br>Indicate Name of International Airport<br>Indicate method of packing done: | AGREE                 |                  |

BHEL-EDN

VENDOR'S SIGNATURE WITH SEAL



RFQ No.: PKN0000031 DATED 23.12.2013

**Electronics Division, Bangalore****BHEL STANDARD COMMERCIAL TERMS AND CONDITIONS FOR IMPORTED SCOPE OF SUPPLY**

| SL. NO. | TERMS                                                                                                                   | BHEL ACCEPTABLE TERM                                                                                                                                                                                                                                                                                                                                                                                                                                                                                                                                                                                                                                                                                                                                                                                                                                 | BIDDER'S CONFIRMATION | DEVIATION IF ANY |
|---------|-------------------------------------------------------------------------------------------------------------------------|------------------------------------------------------------------------------------------------------------------------------------------------------------------------------------------------------------------------------------------------------------------------------------------------------------------------------------------------------------------------------------------------------------------------------------------------------------------------------------------------------------------------------------------------------------------------------------------------------------------------------------------------------------------------------------------------------------------------------------------------------------------------------------------------------------------------------------------------------|-----------------------|------------------|
|         |                                                                                                                         | <p><b>Note : Name of Airport to be selected from any one of the ports indicated in Annexure-V which are acceptable BHEL ports.</b></p> <p><b>BHEL will do Customs Clearance after payment of Customs Duty as applicable at the time of customs clearance.</b></p>                                                                                                                                                                                                                                                                                                                                                                                                                                                                                                                                                                                    |                       |                  |
| 07      | <p><b>DOCUMENTS</b><br/>(Pl. see loading Factor)</p>                                                                    | <p><b>ALONG WITH QUOTATION :</b> As called in Purchase specification shall be furnished alongwith un-price bid.</p> <p>If not called in Purchase Specification then vendor shall submit 2 sets of Original catalogues, Data sheets, Bill of materials, Dimensional drawings, mounting details and any other relevant documents with un-priced bid.</p> <p><b>After issue of PO :</b> As called in Purchase specification. For the complete scope of supply within 2 weeks from receipt of PO for BHEL/ customer/consultant approval.</p> <p>If not called in Purchase Specification then vendor shall submit 2 sets of Drawings, Bill of materials data sheets, Catalogues, Quality Plan, Test procedure and Type Test report for the complete scope of supply within <b>two weeks</b> on receipt of PO for BHEL/ Customer/ Consultant approval.</p> | <b>AGREE</b>          |                  |
| 08.     | <p><b>PENALTY (FOR DELAY IN SUBMISSION OF DOCUMENTS FOR BHEL/ CUSTOMER APPROVAL) :</b><br/>(Pl. see loading Factor)</p> | <p>In the event of delay in submission of complete set of documents (including soft copy) in required sets beyond 2 weeks from receipt of Purchase order, (vendor to confirm date of receipt of PO in Writing) Penalty @ 2% (Two Percent) per week but limited to a max of 10% (Ten percent) value of the basic material cost will be applicable.</p> <p>Penalty if applicable shall be deducted at the time of settlement of 90% payment.</p> <p>If penalty is applicable for duration of less than a week, penalty @ 2% (Two percent) of the basic material value will be charged.</p>                                                                                                                                                                                                                                                             | <b>AGREE</b>          |                  |

BHEL-EDN

VENDOR'S SIGNATURE WITH SEAL



RFQ No.: PKN0000031 DATED 23.12.2013

**Electronics Division, Bangalore****BHEL STANDARD COMMERCIAL TERMS AND CONDITIONS FOR IMPORTED SCOPE OF SUPPLY**

| SL. NO. | TERMS                                                                     | BHEL ACCEPTABLE TERM                                                                                                                                                                                                                                                                                                                                                                                                                                                                                                                          | BIDDER'S CONFIRMATION      | DEVIATION IF ANY |
|---------|---------------------------------------------------------------------------|-----------------------------------------------------------------------------------------------------------------------------------------------------------------------------------------------------------------------------------------------------------------------------------------------------------------------------------------------------------------------------------------------------------------------------------------------------------------------------------------------------------------------------------------------|----------------------------|------------------|
| 09      | <b>TRANSIT INSURANCE</b>                                                  | By BHEL. Insurance Agency Name, Policy No. will be indicated in PO. Vendor to send despatch details by fax to Insurance Agency after items are despatched without fail and copy of same to be submitted along with negotiable documents.                                                                                                                                                                                                                                                                                                      | <b>AGREE</b>               |                  |
| 10      | <b>DELIVERY PERIOD</b><br>(Pl. see loading Factor)                        | For Sagardighi 2 units : within 8 weeks from document approval or mfg claims by BHEL. whichever is earlier.<br>For other project ref SCC.                                                                                                                                                                                                                                                                                                                                                                                                     | <b>AGREE</b>               |                  |
| 11      | <b>WARRANTY</b><br>(Pl. see loading Factor)                               | 30 months from the date of despatch or 24 months from the date of commissioning whichever is earlier.<br>Please indicate charges if any, in % of Total Basic material value for extended warranty per annum, if BHEL decides to have at later stage.<br>Please note, extended warranty charges will not be considered for evaluation of lowest bidder.                                                                                                                                                                                        | <b>AGREE</b><br><br>-----% |                  |
| 12      | <b>TERMS OF PAYMENT (FOR MATERIAL SUPPLY)</b><br>(Pl. see loading Factor) | Against " <b>SIGHT DRAFT</b> " on presentation of documents to our Bankers.<br>The payment terms are as follows :<br>a) 90% is payable on negotiation of complete set of original documents including original performance Bank Guarantee .<br><br>Note : In case PBG is not furnished only 80 % payment will be released against 90 % claim. Hence claim only 80 %.<br>b) Balance 10% on 60th day from the date of Air Way Bill / Bill of Lading & against specific authorisation by BHEL.<br><b>Note : No advance payment will be made.</b> | <b>AGREE</b>               |                  |
| 13      | <b>SHORTAGES/ DAMAGES AT CUSTOMER SITE</b>                                | In the event of shortage / damage on receipt of goods and on opening of packages at site all such shortages / damages shall be made good within reasonable time of such intimation and cost of such material will be reimbursed only on settlement of Insurance claim limited to insurance settled amount.                                                                                                                                                                                                                                    | <b>AGREE</b>               |                  |

BHEL-EDN

VENDOR'S SIGNATURE WITH SEAL



RFQ No.: PKN0000031 DATED 23.12.2013

**Electronics Division, Bangalore****BHEL STANDARD COMMERCIAL TERMS AND CONDITIONS FOR IMPORTED SCOPE OF SUPPLY**

| SL. NO. | TERMS                                                               | BHEL ACCEPTABLE TERM                                                                                                                                                                                                                                                                                                                                                                                                                                                                                                                                                                                                                                                                                                                                                                                                                                                                                                                             | BIDDER'S CONFIRMATION | DEVIATION IF ANY |
|---------|---------------------------------------------------------------------|--------------------------------------------------------------------------------------------------------------------------------------------------------------------------------------------------------------------------------------------------------------------------------------------------------------------------------------------------------------------------------------------------------------------------------------------------------------------------------------------------------------------------------------------------------------------------------------------------------------------------------------------------------------------------------------------------------------------------------------------------------------------------------------------------------------------------------------------------------------------------------------------------------------------------------------------------|-----------------------|------------------|
| 14      | <b>PENALTY</b><br>(Pl. see loading Factor)                          | <p>In the event of delay in agreed contractual delivery, penalty @ 2 % ( two percent ) per week but limited to a max of 10% (Ten percent) value of undelivered basic material (excluding packing) portion will be applicable. Date of issue of test certificates / Test Reports / Certificate of Conformance / Calibration reports, as proof of completion of manufacturing will be treated as date of despatch for penalty calculation. Penalty will be applicable after 8 weeks for Sagardighi &amp; Muzafferpur and 16 weeks for other projects from the date of document approval or manufacturing clearance, whichever is earlier .</p> <p>Penalty if applicable shall be deducted at the time of settlement of 90% payment. Penalty if any will be indicated in Despatch Clearance letter.</p> <p>If penalty is applicable for duration of less than a week, penalty @2 % ( two percent ) of the basic material value will be charged.</p> | <b>AGREE</b>          |                  |
| 15      | <b>PERFORMANCE BANK GUARANTEE (PBG)</b><br>(Pl. see loading Factor) | <p>PBG for 10% of the basic material cost shall be furnished strictly in the BHEL prescribed format only (Annexure-II ), directly to BHEL from issuing bank for payment. Copy of PBG shall be furnished to BHEL.</p> <p>PBG shall be valid for 30 months + 6 months claim period (totally 36 months) from the date of despatch PBG proforma enclosed herewith (Annexure-II).</p> <p>If PBG is not submitted as per enclosed BHEL standard proforma, i.e., PBG is submitted in Vendor's format (other than BHEL proforma), it will be treated as Vendor has not agreed for PBG clause (non submission of PBG only) and price will be loaded as per the loading factors enclosed (Annexure - I) to arrive at " total cost to BHEL".</p>                                                                                                                                                                                                            | <b>AGREE</b>          |                  |

**BHEL-EDN****VENDOR'S SIGNATURE WITH SEAL**



RFQ No.: PKN0000031 DATED 23.12.2013

**Electronics Division, Bangalore****BHEL STANDARD COMMERCIAL TERMS AND CONDITIONS FOR IMPORTED SCOPE OF SUPPLY**

| SL. NO. | TERMS                                     | BHEL ACCEPTABLE TERM                                                                                                                                                                                                                                                                                                                                                                                                                                                                                                                                                                                                                                                                                                                                          | BIDDER'S CONFIRMATION | DEVIATION IF ANY |
|---------|-------------------------------------------|---------------------------------------------------------------------------------------------------------------------------------------------------------------------------------------------------------------------------------------------------------------------------------------------------------------------------------------------------------------------------------------------------------------------------------------------------------------------------------------------------------------------------------------------------------------------------------------------------------------------------------------------------------------------------------------------------------------------------------------------------------------|-----------------------|------------------|
| 16      | <b>TEST REPORTS / CALIBRATION REPORTS</b> | <p>Shall be furnished / faxed immediately on completion of testing to BHEL for verification</p> <p>All tests have to be conducted as applicable in line with approved Quality plan or QA Checklist or Purchase specification and original reports shall be furnished to BHEL-EDN, Bangalore for verification / acceptance and issue of despatch clearance.</p>                                                                                                                                                                                                                                                                                                                                                                                                | <b>AGREE</b>          |                  |
| 17      | <b>MODE OF DESPATCH</b>                   | BY <b>Air / sea</b> freight on receipt of despatch clearance from BHEL and through BHEL approved Consolidator / freight Forwarder .                                                                                                                                                                                                                                                                                                                                                                                                                                                                                                                                                                                                                           | <b>AGREE</b>          |                  |
| 18      | <b>DOCUMENTS DESPATCH</b>                 | <p>Complete set of despatch documents shall be forwarded to BHEL directly. Despatch documents include AWB / BOL, Invoice, Packing list, Country of origin certificate, Original performance Bank Guarantee, Warranty certificate, O &amp; M manuals and Insurance intimation letter.</p> <p>One copy of Invoice, Packing list and A WB / BOL shall be faxed immediately after despatch. Also one copy of packing list to be kept inside each box for easy identification of material at site.</p> <p><b>Note : The Invoice shall be complete with item Nomenclature, Description, Unit, Quantity as per Purchase Order. Deviation to these will lead to financial losses to BHEL during Custom Clearance, which will have to be borne by Vendor only.</b></p> | <b>AGREE</b>          |                  |
| 19      | <b>WEIGHT &amp; VOLUME</b>                | <p>Please indicate following for calculating Freight charges <b>(approximate)</b> :</p> <p>a) <b>Total Net Weight of the package/s.</b></p> <p>b) <b>Total Gross weight of the package/s.</b></p> <p>c) <b>VOLUME : Length (L) X Breadth (B) X Height (H) in feet X No. of packages. Please keep one copy of packing slip inside box.</b></p>                                                                                                                                                                                                                                                                                                                                                                                                                 | <b>FURNISHED</b>      |                  |
| 20      | <b>O &amp; M MANUALS</b>                  | <p>As built Drawings, O&amp;M Manuals and other approved documents in 2 sets shall be furnished immediately after despatch to BHEL directly.</p> <p>1 set of above also shall be sent in soft media (CD ROM) wherever called in specification</p> <p>Two sets of hard copies shall be directly despatched to site alongwith the material.</p> <p>Refer Specification for details.</p>                                                                                                                                                                                                                                                                                                                                                                         | <b>AGREE</b>          |                  |

BHEL-EDN

VENDOR'S SIGNATURE WITH SEAL



RFQ No.: PKN0000031 DATED 23.12.2013

**Electronics Division, Bangalore****BHEL STANDARD COMMERCIAL TERMS AND CONDITIONS FOR IMPORTED SCOPE OF SUPPLY**

| SL. NO. | TERMS                       | BHEL ACCEPTABLE TERM                                                                                                                                                                                                                                                                                                                  | BIDDER'S CONFIRMATION                                           | DEVIATION IF ANY                                  |
|---------|-----------------------------|---------------------------------------------------------------------------------------------------------------------------------------------------------------------------------------------------------------------------------------------------------------------------------------------------------------------------------------|-----------------------------------------------------------------|---------------------------------------------------|
|         |                             | Note : Supply of above documents (O&M) in required No. of sets along with Despatch documents and material shall be indicated in packing slip. If not mentioned, BHEL may insist above in required No. of sets.                                                                                                                        |                                                                 |                                                   |
| 21      | <b>SPLIT ORDERING</b>       | Package purchase as per details given in SCC                                                                                                                                                                                                                                                                                          | <b>AGREE</b>                                                    |                                                   |
| 22      | <b>QUANTITY TOLERANCE</b>   | <del>Wherever Purchase specification indicate quantity tolerance, it is to be confirmed. It may be confirmed as per Vendor's company norms. This is applicable for items having running length like Impluse Pipes, Cables, etc. For Impluse/ seamless pipes one random length of (+) plus 6 metres applicable for each variety.</del> | <b>CONFIRMED</b>                                                | <b>QUANTITY TOLERANCE<br/>.....% PER<br/>ITEM</b> |
| 23      | <b>SLAB RATE</b>            | Slab rates as per details given in SCC                                                                                                                                                                                                                                                                                                | <b>AGREE</b>                                                    |                                                   |
| 24      | <b>PARTIAL SHIPMENT</b>     | NOT ALLOWED WITH IN A PROJECT                                                                                                                                                                                                                                                                                                         | <b>NOTED</b>                                                    |                                                   |
| 25      | <b>TRANSHIPMENT</b>         | ALLOWED                                                                                                                                                                                                                                                                                                                               | <b>NOTED</b>                                                    |                                                   |
| 26      | <b>DESPATCH CLEARANCE</b>   | BHEL will issue despatch clearance on receipt Test Certificates/calibration reports/ Certificates of Conformance and review / verification o f the same.<br><br>Goods shall not be despatched without obtaining despatch clearance from BHEL.                                                                                         | <b>AGREE</b>                                                    |                                                   |
| 27      | <b>REPAIR OF COMPONENTS</b> | For imported items, during commissioning/ warranty period, repair of failed components will be undertaken by your Indian representative M/s. _____ and if repair is not possible in India, then free replacement of components will be made by Foreign vendor without any commercial implications to BHEL.                            | <b>AGREE</b><br><br><b>INDIAN REPRESENTATIVE NAME INDICATED</b> |                                                   |

BHEL-EDN

VENDOR'S SIGNATURE WITH SEAL



RFQ No.: PKN0000031 DATED 23.12.2013

**Electronics Division, Bangalore****BHEL STANDARD COMMERCIAL TERMS AND CONDITIONS FOR IMPORTED SCOPE OF SUPPLY**

| SL. NO. | TERMS           | BHEL ACCEPTABLE TERM                                                                                                                                                                                                                                                                                                                                                                                                                                                                                                                                                                                                                                                                                                                                                                                                                                                                                                                                                                         | BIDDER'S CONFIRMATION | DEVIATION IF ANY |
|---------|-----------------|----------------------------------------------------------------------------------------------------------------------------------------------------------------------------------------------------------------------------------------------------------------------------------------------------------------------------------------------------------------------------------------------------------------------------------------------------------------------------------------------------------------------------------------------------------------------------------------------------------------------------------------------------------------------------------------------------------------------------------------------------------------------------------------------------------------------------------------------------------------------------------------------------------------------------------------------------------------------------------------------|-----------------------|------------------|
| 28      | REMARKS         | <p>Please note all the above will form part of Purchase Order and in case Vendor asks for payments, through letter of credit, all the above agreed terms will form part of letter of credit.</p> <p>In case Indian representative quotes on behalf of their Foreign counterpart, acceptance to the above terms are to be confirmed in writing by foreign vendor without fail and such confirmation shall be furnished as part of the un-priced bid.</p>                                                                                                                                                                                                                                                                                                                                                                                                                                                                                                                                      | AGREE                 |                  |
| 29      | REVERSE AUCTION | <p>BHEL reserves the right to go for Reverse Auction (RA) instead of opening the sealed envelope price bid, submitted by the bidder. This will be decided after techno-commercial evaluation. All bidders to give their acceptance for participation in RA. Non-acceptance to participate in RA may result in non-consideration of their bids, in case BHEL decides to go for RA. In case BHEL decides to go for Reverse Auction, only those bidders who have given their acceptance to participate in RA will be allowed to participate in the Reverse Auction. Those bidders who have given their acceptance to participate in Reverse Auction will have to necessarily submit „online sealed bid“ in the Reverse Auction. Non-submission of "online sealed bid" by the bidder will be considered as tampering of the tender process and will invite action by BHEL as per extant guidelines in vogue." Information and General Terms and Conditions governing RA given Annexure - IV.</p> | AGREE                 |                  |
| 30      | SPECIAL CLAUSE  | <p>Articles packed with raw/solid wood packing material should be treated as per ISPM-15 and accomplished by a phytosanitary Certificate.</p>                                                                                                                                                                                                                                                                                                                                                                                                                                                                                                                                                                                                                                                                                                                                                                                                                                                | AGREE                 |                  |

**THE ABOVE FILLED-IN AND SIGNED DOCUMENT SHALL BE FURNISHED AS PART OF UN-PRICED CUM-TECHNICAL BID WITHOUT FAIL.**

**NOTE : LOWEST BIDDER WILL BE DECIDED BASED ON THE "TOTAL COST TO BHEL" BASIS INCLUDING LOADING FACTORS (FOR DEVIATIONS TO BHEL STANDARD COMMERCIAL TERMS & CONDITIONS).**

BHEL-EDN

VENDOR'S SIGNATURE WITH SEAL





RFQ No.: PKN0000031 DATED 23.12.2013

**Electronics Division, Bangalore****BHEL STANDARD COMMERCIAL TERMS AND CONDITIONS FORHSS SCOPE OF SUPPLY**

| SL. NO. | TERMS                                                                              | BHEL ACCEPTABLE TERM                                                                                                                                                                                                                                                                                                                                                                                                                       | BIDDER'S CONFIRMATION | DEVIATION IF ANY |
|---------|------------------------------------------------------------------------------------|--------------------------------------------------------------------------------------------------------------------------------------------------------------------------------------------------------------------------------------------------------------------------------------------------------------------------------------------------------------------------------------------------------------------------------------------|-----------------------|------------------|
| 01      | COUNTRY OF ORIGIN & PLACE OF MANUFACTURE - RING                                    | PL INDICATE FOR THE TOTAL SCOPE OF SUPPLY<br><b>COUNTRY OF ORIGIN</b><br><br><b>PLACE OF MANUFACTURING (TOTAL PACKAGES)</b>                                                                                                                                                                                                                                                                                                                | FURNISHED             |                  |
| 02      | NAME & ADDRESS OF THE BIDDER :<br>A) IN PURCHASE ORDER                             |                                                                                                                                                                                                                                                                                                                                                                                                                                            | FURNISHED             |                  |
| 03      | <del>NAME</del><br><del>ADDRESS OF FOREIGN BANK ACCOUNT NO. &amp; SWIFT CODE</del> |                                                                                                                                                                                                                                                                                                                                                                                                                                            | <del>FURNISHED</del>  |                  |
| 04      | PRICE BASIS & CURRENCY                                                             | Firm i.e., from the PO date to completion of supply<br><b>(Price variation Clause not acceptable).</b><br>Currency :                                                                                                                                                                                                                                                                                                                       | AGREE                 |                  |
| 05      | VALIDITY                                                                           | Valid up to 8 weeks from the date of opening of price Bid <b>(not technical bid).</b>                                                                                                                                                                                                                                                                                                                                                      | AGREE                 |                  |
| 06.     | TERMS OF DELIVERY                                                                  | Price offered shall be for goods packed and delivered C.I.F, MUMBAI / BANGALORE including Packing, Forwarding, Handling, Ancillary charges like processing of Sight Draft , negotiation of Bank Documents, Export declaration, Certificate of Origin, etc. Packing shall be Airworthy, best suited for transshipment and to take care of transit damages<br><br>Indicate Name of International Airport<br>Indicate method of packing done: | AGREE                 |                  |

BHEL-EDN

VENDOR'S SIGNATURE WITH SEAL



RFQ No.: PKN0000031 DATED 23.12.2013

## Electronics Division, Bangalore

## BHEL STANDARD COMMERCIAL TERMS AND CONDITIONS FORHSS SCOPE OF SUPPLY

| SL. NO. | TERMS                                                                                                                   | BHEL ACCEPTABLE TERM                                                                                                                                                                                                                                                                                                                                                                                                                                                                                                                                                                                                                                                                                                                                                                                                                                 | BIDDER'S CONFIRMATION | DEVIATION IF ANY |
|---------|-------------------------------------------------------------------------------------------------------------------------|------------------------------------------------------------------------------------------------------------------------------------------------------------------------------------------------------------------------------------------------------------------------------------------------------------------------------------------------------------------------------------------------------------------------------------------------------------------------------------------------------------------------------------------------------------------------------------------------------------------------------------------------------------------------------------------------------------------------------------------------------------------------------------------------------------------------------------------------------|-----------------------|------------------|
|         |                                                                                                                         | <p><del>Note : Name of Airport to be selected from any one of the ports indicated in Annexure-V which are acceptable BHEL ports.</del></p> <p><b>BHEL will do Customs Clearance after payment of Customs Duty as applicable at the time of customs clearance.</b></p>                                                                                                                                                                                                                                                                                                                                                                                                                                                                                                                                                                                |                       |                  |
| 07      | <p><b>DOCUMENTS</b><br/>(Pl. see loading Factor)</p>                                                                    | <p><b>ALONG WITH QUOTATION :</b> As called in Purchase specification shall be furnished alongwith un-price bid.</p> <p>If not called in Purchase Specification then vendor shall submit 2 sets of Original catalogues, Data sheets, Bill of materials, Dimensional drawings, mounting details and any other relevant documents with un-priced bid.</p> <p><b>After issue of PO :</b> As called in Purchase specification. For the complete scope of supply within 2 weeks from receipt of PO for BHEL/ customer/consultant approval.</p> <p>If not called in Purchase Specification then vendor shall submit 2 sets of Drawings, Bill of materials data sheets, Catalogues, Quality Plan, Test procedure and Type Test report for the complete scope of supply within <b>two weeks</b> on receipt of PO for BHEL/ Customer/ Consultant approval.</p> | <b>AGREE</b>          |                  |
| 08.     | <p><b>PENALTY (FOR DELAY IN SUBMISSION OF DOCUMENTS FOR BHEL/ CUSTOMER APPROVAL) :</b><br/>(Pl. see loading Factor)</p> | <p>In the event of delay in submission of complete set of documents (including soft copy) in required sets beyond 2 weeks from receipt of Purchase order, (vendor to confirm date of receipt of PO in Writing) Penalty @ 2% (Two Percent) per week but limited to a max of 10% (Ten percent) value of the basic material cost will be applicable.</p> <p>Penalty if applicable shall be deducted at the time of settlement of 90% payment.</p> <p>If penalty is applicable for duration of less than a week, penalty @ 2% (Two percent) of the basic material value will be charged.</p>                                                                                                                                                                                                                                                             | <b>AGREE</b>          |                  |

BHEL-EDN

VENDOR'S SIGNATURE WITH SEAL



RFQ No.: PKN0000031 DATED 23.12.2013

**Electronics Division, Bangalore****BHEL STANDARD COMMERCIAL TERMS AND CONDITIONS FOR HSS SCOPE OF SUPPLY**

| SL. NO. | TERMS                                                                     | BHEL ACCEPTABLE TERM                                                                                                                                                                                                                                                                                                                                                                               | BIDDER'S CONFIRMATION      | DEVIATION IF ANY |
|---------|---------------------------------------------------------------------------|----------------------------------------------------------------------------------------------------------------------------------------------------------------------------------------------------------------------------------------------------------------------------------------------------------------------------------------------------------------------------------------------------|----------------------------|------------------|
| 09      | <b>TRANSIT INSURANCE</b>                                                  | By BHEL. Insurance Agency Name, Policy No. will be indicated in PO. Vendor to send despatch details by fax to Insurance Agency after items are despatched without fail and copy of same to be submitted along with negotiable documents.                                                                                                                                                           | <b>AGREE</b>               |                  |
| 10      | <b>DELIVERY PERIOD</b><br>(Pl. see loading Factor)                        | For Sagardighi 2 units & Muzafferpur 2 units: within 8 weeks from document approval or mfg clms by BHEL. whichever is earlier.<br><br>For other project within 16 weeks from document approval or mfg clms by BHEL. whichever is earlier.                                                                                                                                                          | <b>AGREE</b>               |                  |
| 11      | <b>WARRANTY</b><br>(Pl. see loading Factor)                               | 30 months from the date of despatch or 24 months from the date of commissioning whichever is earlier.<br><br>Please indicate charges if any, in % of Total Basic material value for extended warranty per annum, if BHEL decides to have at later stage.<br><br>Please note, extended warranty charges will not be considered for evaluation of lowest bidder.                                     | <b>AGREE</b><br><br>-----% |                  |
| 12      | <b>TERMS OF PAYMENT (FOR MATERIAL SUPPLY)</b><br>(Pl. see loading Factor) | a) 90 % of CIF value with 45 days credit from the date of exchange of original High Sea Sales documents. Original Performance Bank Garrantee (Received from bank directly) also should be submitted along with 90 % claim. .<br><br>b) Balance 10% on 60th day from the date of Air Way Bill / BOL & against specific authorisation by BHEL.<br><br><b>Note : No advance payment will be made.</b> | <b>AGREE</b>               |                  |
| 13      | <b>SHORTAGES/ DAMAGES AT CUSTOMER SITE</b>                                | In the event of shortage / damage on receipt of goods and on opening of packages at site all such shortages / damages shall be made good within reasonable time of such intimation and cost of such material will be reimbursed only on settlement of Insurance claim limited to insurance settled amount.                                                                                         | <b>AGREE</b>               |                  |

BHEL-EDN

VENDOR'S SIGNATURE WITH SEAL



RFQ No.: PKN0000031 DATED 23.12.2013

**Electronics Division, Bangalore****BHEL STANDARD COMMERCIAL TERMS AND CONDITIONS FOR HSS SCOPE OF SUPPLY**

| SL. NO. | TERMS                                                               | BHEL ACCEPTABLE TERM                                                                                                                                                                                                                                                                                                                                                                                                                                                                                                                                                                                                                                                                                                                                                                                                                                                                                                                                                            | BIDDER'S CONFIRMATION | DEVIATION IF ANY |
|---------|---------------------------------------------------------------------|---------------------------------------------------------------------------------------------------------------------------------------------------------------------------------------------------------------------------------------------------------------------------------------------------------------------------------------------------------------------------------------------------------------------------------------------------------------------------------------------------------------------------------------------------------------------------------------------------------------------------------------------------------------------------------------------------------------------------------------------------------------------------------------------------------------------------------------------------------------------------------------------------------------------------------------------------------------------------------|-----------------------|------------------|
| 14      | <b>PENALTY</b><br>(Pl. see loading Factor)                          | <p>In the event of delay in agreed contractual delivery, penalty @ 2 % ( two percent ) per week but limited to a max of 10% (Ten percent) value of undelivered basic material (excluding packing) portion will be applicable. Date of issue of test certificates / Test Reports / Certificate of Conformance / Calibration reports, as proof of completion of manufacturing will be treated as date of despatch for penalty calculation. Penalty will be applicable after 8 weeks for Sagardighi &amp; Muzafferpur and 16 weeks for other projects from the date of document approval or manufacturing clearance, whichever is earlier. For other projects plz ref SCC.</p> <p>Penalty if applicable shall be deducted at the time of settlement of 90% payment. Penalty if any will be indicated in Despatch Clearance letter.</p> <p>If penalty is applicable for duration of less than a week, penalty @2 % ( two percent ) of the basic material value will be charged.</p> | <b>AGREE</b>          |                  |
| 15      | <b>PERFORMANCE BANK GUARANTEE (PBG)</b><br>(Pl. see loading Factor) | <p>PBG for 10% of the basic material cost shall be furnished strictly in the BHEL prescribed format only (Annexure-II ), directly to BHEL from issuing bank for payment. Copy of PBG shall be furnished to BHEL.</p> <p>PBG shall be valid for 30 months + 6 months claim period (totally 36 months) from the date of despatch PBG proforma enclosed herewith (Annexure-II).</p> <p><del>If PBG is not submitted as per enclosed BHEL standard proforma, i.e., PBG is submitted in Vendor's format (other than BHEL proforma), it will be treated as Vendor has not agreed for PBG clause (non-submission of PBG only) and price will be loaded as per the loading factors enclosed (Annexure-I) to arrive at " total cost to BHEL".</del></p>                                                                                                                                                                                                                                  | <b>AGREE</b>          |                  |

**BHEL-EDN****VENDOR'S SIGNATURE WITH SEAL**



RFQ No.: PKN0000031 DATED 23.12.2013

**Electronics Division, Bangalore****BHEL STANDARD COMMERCIAL TERMS AND CONDITIONS FOR HSS SCOPE OF SUPPLY**

| SL. NO. | TERMS                                     | BHEL ACCEPTABLE TERM                                                                                                                                                                                                                                                                                                                                                                                                                                                                                                                                                                                                                                                                                                                                                                                                                       | BIDDER'S CONFIRMATION | DEVIATION IF ANY |
|---------|-------------------------------------------|--------------------------------------------------------------------------------------------------------------------------------------------------------------------------------------------------------------------------------------------------------------------------------------------------------------------------------------------------------------------------------------------------------------------------------------------------------------------------------------------------------------------------------------------------------------------------------------------------------------------------------------------------------------------------------------------------------------------------------------------------------------------------------------------------------------------------------------------|-----------------------|------------------|
| 16      | <b>TEST REPORTS / CALIBRATION REPORTS</b> | <p>Shall be furnished / faxed immediately on completion of testing to BHEL for verification</p> <p>All tests have to be conducted as applicable in line with approved Quality plan or QA Checklist or Purchase specification and original reports shall be furnished to BHEL-EDN, Bangalore for verification / acceptance and issue of despatch clearance.</p>                                                                                                                                                                                                                                                                                                                                                                                                                                                                             | <b>AGREE</b>          |                  |
| 17      | <b>MODE OF DESPATCH</b>                   | BY <b>Air / Sea</b> freight on receipt of despatch clearance from BHEL and through your Consolidator /freight Forwarder.                                                                                                                                                                                                                                                                                                                                                                                                                                                                                                                                                                                                                                                                                                                   | <b>AGREE</b>          |                  |
| 18      | <b>DOCUMENTS DESPATCH</b>                 | <p>Complete set of despatch documents shall be forwarded to BHEL directly. Despatch documents include AWB, Invoice from OEM, in forign currancy and Invoice from Indian representative / agent in INR, Packing list, Countr y of origin certificate, Original per formance Bank Guarantee, Warranty certificate, O &amp; M manuals and Insurance intimation letter.</p> <p>One copy of Invoice, Packing list and AW B/BOL shall be faxed immediately after despatch. Also one copy of packing list to be kept inside each box for easy identification of material at site.</p> <p><b>Note : The Invoice shall be complete with item Nomenclature, Description, Unit, Quantity as per Purchase Order. Deviation to these will lead to financial losses to BHEL during Custom Clearance, which will have to be borne by Vendor only.</b></p> | <b>AGREE</b>          |                  |
| 19      | <b>WEIGHT &amp; VOLUME</b>                | <p>Please indicate following for calculating Freight charges (<b>approximate</b>) :</p> <p><b>Total Net Weight of the package/s.</b></p> <p><b>Total Gross weight of the package/s.</b></p> <p><b>VOLUME : Length (L) X Breadth (B) X Height (H) in feet X No. of packages. Please keep one copy of packing slip inside box.</b></p>                                                                                                                                                                                                                                                                                                                                                                                                                                                                                                       | <b>FURNISHED</b>      |                  |
| 20      | <b>O &amp; M MANUALS</b>                  | <p>As built Drawings, O&amp;M Manuals and other approved documents in 2 sets shall be furnished immediately after despatch to BHEL directly.</p> <p>1 set of above also shall be sent in soft media (CD ROM) w herever called in specification</p> <p>Two sets of hard copies shall be directly despatched to site alongwith the material.</p> <p>Refer Specification for details.</p>                                                                                                                                                                                                                                                                                                                                                                                                                                                     | <b>AGREE</b>          |                  |

BHEL-EDN

VENDOR'S SIGNATURE WITH SEAL



RFQ No.: PKN0000031 DATED 23.12.2013

**Electronics Division, Bangalore****BHEL STANDARD COMMERCIAL TERMS AND CONDITIONS FOR HSS SCOPE OF SUPPLY**

| SL. NO. | TERMS                       | BHEL ACCEPTABLE TERM                                                                                                                                                                                                                                                                                                                  | BIDDER'S CONFIRMATION                                           | DEVIATION IF ANY                                  |
|---------|-----------------------------|---------------------------------------------------------------------------------------------------------------------------------------------------------------------------------------------------------------------------------------------------------------------------------------------------------------------------------------|-----------------------------------------------------------------|---------------------------------------------------|
|         |                             | Note : Supply of above documents (O&M) in required No. of sets along with Despatch documents and material shall be indicated in packing slip. If not mentioned, BHEL may insist above in required No. of sets.                                                                                                                        |                                                                 |                                                   |
| 21      | <b>SPLIT ORDERING</b>       | Package purchase as per details given in SCC                                                                                                                                                                                                                                                                                          | <b>AGREE</b>                                                    |                                                   |
| 22      | <b>QUANTITY TOLERANCE</b>   | <del>Wherever Purchase specification indicate quantity tolerance, it is to be confirmed. It may be confirmed as per Vendor's company norms. This is applicable for items having running length like Impluse Pipes, Cables, etc. For Impluse/ seamless pipes one random length of (+) plus 6 metres applicable for each variety.</del> | <b>CONFIRMED</b>                                                | <b>QUANTITY TOLERANCE<br/>.....% PER<br/>ITEM</b> |
| 23      | <b>SLAB RATE</b>            | Slab rates as per SCC                                                                                                                                                                                                                                                                                                                 | <b>AGREE</b>                                                    |                                                   |
| 24      | <b>PARTIAL SHIPMENT</b>     | NOT ALLOWED WITH IN A PROJECT                                                                                                                                                                                                                                                                                                         | <b>NOTED</b>                                                    |                                                   |
| 25      | <b>TRANSHIPMENT</b>         | ALLOWED                                                                                                                                                                                                                                                                                                                               | <b>NOTED</b>                                                    |                                                   |
| 26      | <b>DESPATCH CLEARANCE</b>   | BHEL will issue despatch clearance on receipt Test Certificates/calibration reports/ Certificates of Conformance and review / verification o f the same.<br><br>Goods shall not be despatched without obtaining despatch clearance from BHEL.                                                                                         | <b>AGREE</b>                                                    |                                                   |
| 27      | <b>REPAIR OF COMPONENTS</b> | For imported items, during commissioning/ warranty period, repair of failed components will be undertaken by your Indian representative M/s. _____ and if repair is not possible in India, then free replacement of components will be made by Foreign vendor without any commercial implications to BHEL.                            | <b>AGREE</b><br><br><b>INDIAN REPRESENTATIVE NAME INDICATED</b> |                                                   |

BHEL-EDN

VENDOR'S SIGNATURE WITH SEAL



RFQ No.: PKN0000031 DATED 23.12.2013

**Electronics Division, Bangalore****BHEL STANDARD COMMERCIAL TERMS AND CONDITIONS FOR HSS SCOPE OF SUPPLY**

| SL. NO. | TERMS           | BHEL ACCEPTABLE TERM                                                                                                                                                                                                                                                                                                                                                                                                                                                                                                                                                                                                                                                                                                                                                                                                                                                                                                                                                                         | BIDDER'S CONFIRMATION | DEVIATION IF ANY |
|---------|-----------------|----------------------------------------------------------------------------------------------------------------------------------------------------------------------------------------------------------------------------------------------------------------------------------------------------------------------------------------------------------------------------------------------------------------------------------------------------------------------------------------------------------------------------------------------------------------------------------------------------------------------------------------------------------------------------------------------------------------------------------------------------------------------------------------------------------------------------------------------------------------------------------------------------------------------------------------------------------------------------------------------|-----------------------|------------------|
| 28      | REMARKS         | <p>Please note all the above will form part of Purchase Order and in case Vendor asks for payments, through letter of credit, all the above agreed terms will form part of letter of credit.</p> <p>In case Indian representative quotes on behalf of their Foreign counterpart, acceptance to the above terms are to be confirmed in writing by foreign vendor without fail and such confirmation shall be furnished as part of the un-priced bid.</p>                                                                                                                                                                                                                                                                                                                                                                                                                                                                                                                                      | AGREE                 |                  |
| 29      | REVERSE AUCTION | <p>BHEL reserves the right to go for Reverse Auction (RA) instead of opening the sealed envelope price bid, submitted by the bidder. This will be decided after techno-commercial evaluation. All bidders to give their acceptance for participation in RA. Non-acceptance to participate in RA may result in non-consideration of their bids, in case BHEL decides to go for RA. In case BHEL decides to go for Reverse Auction, only those bidders who have given their acceptance to participate in RA will be allowed to participate in the Reverse Auction. Those bidders who have given their acceptance to participate in Reverse Auction will have to necessarily submit „online sealed bid“ in the Reverse Auction. Non-submission of "online sealed bid" by the bidder will be considered as tampering of the tender process and will invite action by BHEL as per extant guidelines in vogue." Information and General Terms and Conditions governing RA given Annexure - IV.</p> | AGREE                 |                  |
| 30      | SPECIAL CLAUSE  | <p>Articles packed with raw/solid wood packing material should be treated as per ISPM-15 and accomplished by a phytosanitary Certificate.</p>                                                                                                                                                                                                                                                                                                                                                                                                                                                                                                                                                                                                                                                                                                                                                                                                                                                | AGREE                 |                  |

**THE ABOVE FILLED-IN AND SIGNED DOCUMENT SHALL BE FURNISHED AS PART OF UN-PRICED CUM-TECHNICAL BID WITHOUT FAIL.**

**NOTE : LOWEST BIDDER WILL BE DECIDED BASED ON THE "TOTAL COST TO BHEL" BASIS INCLUDING LOADING FACTORS (FOR DEVIATIONS TO BHEL STANDARD COMMERCIAL TERMS & CONDITIONS).**

BHEL-EDN

VENDOR'S SIGNATURE WITH SEAL



**Electronics Division, Bangalore**

**ANNEXURE-I**

**LOADING FACTORS SHEET (8 pages)**

**BHEL RFQ NO. & DATE: PKN000031 DATED 23.12.2013**

**DEVIATIONS ARE LIMITED TO FOLLOWING ONLY, FURTHER DEVIATION ON ANY OF THE FOLLOWING MAY LEAD BHEL TO REJECT THE OFFER UNILATERALLY ON COMMERCIAL GROUNDS.**

**NOTE: THIS LOADING FACTOR INDICATED BELOW WILL BE ADDED ON QUOTED PRICE TO EVALUATE THE LOWEST QUOTE (IN CASE OF DEVIATION TO BHEL'S TENDER SPECIFIED TERMS AGAINST EACH TENDER).**

| SL NO | COMMERCIAL TERMS                             | BHEL STANDARD TERM                                                                                                                                                                                                                                                                                                                                                                                                                                                                                                                                                                                                                                                                                                       | IF YOU QUOTE                                                                                                                                                                                                                                                                      | LOADING FACTOR FOR NON-COMPLIANCE OF BHEL STANDARD TERM |
|-------|----------------------------------------------|--------------------------------------------------------------------------------------------------------------------------------------------------------------------------------------------------------------------------------------------------------------------------------------------------------------------------------------------------------------------------------------------------------------------------------------------------------------------------------------------------------------------------------------------------------------------------------------------------------------------------------------------------------------------------------------------------------------------------|-----------------------------------------------------------------------------------------------------------------------------------------------------------------------------------------------------------------------------------------------------------------------------------|---------------------------------------------------------|
| A.    | FOR INDIGENOUS SCOPE OF SUPPLY.              |                                                                                                                                                                                                                                                                                                                                                                                                                                                                                                                                                                                                                                                                                                                          |                                                                                                                                                                                                                                                                                   |                                                         |
| 1     | TERMS OF PAYMENT (WHERE SCOPE INCLUDES E&C): | a) 75% basic + 100% taxes, duties & freight charges with 45 days credit from the date of receipt of complete set of original despatch documents including Original Performance Bank Guarantee for 10% of the basic material value. (if applicable) to BHEL. b) Balance 10% with 30 days of account of materials at site and proof of supply of O&M manuals in required sets, against a supplementary Invoice and c) Balance 15% with 30 days credit from the date of completion of Erection & commissioning work on pro-rata basis against supplementary Invoice with "Proof of completion of E&C" (like MOM, Site protocol, Job completion certificate, signed by BHEL site office or Customer and your representative. | 90% WITH 45 DAYS CREDIT ALONG WITH ADDITIONAL BG FOR 15% OF THE BASIC MATERIAL VALUE VALID TILL COMPLETION OF COMMISSIONING APART FROM PBG 10% OF THE BASIC MATERIAL VALUE. BALANCE 10% OF MATL COST WITH CREDIT 30 DAYS FROM THE DATE OF RECEIPT OF MATERIAL RECEIPT CERTIFICATE | NIL                                                     |
|       |                                              | -SAME AS ABOVE-                                                                                                                                                                                                                                                                                                                                                                                                                                                                                                                                                                                                                                                                                                          | 100% WITH 45 DAYS CREDIT ALONG WITH ADDITIONAL BG. FOR 25% OF THE BASIC MATERIAL VALUE VALID TILL COMPLETION OF COMMISSIONING APART FROM PBG 10% OF THE BASIC MATERIAL VALUE                                                                                                      | NIL                                                     |





**Electronics Division, Bangalore RFQ No.: PKN0000031 DATED 23.12.2013**

| SL NO | COMMERCIAL TERMS | BHEL STANDARD TERM | IF YOU QUOTE                                                                                                                                                                                                                             | LOADING FACTOR FOR NON-COMPLIANCE OF BHEL STANDARD TERM                             |
|-------|------------------|--------------------|------------------------------------------------------------------------------------------------------------------------------------------------------------------------------------------------------------------------------------------|-------------------------------------------------------------------------------------|
|       |                  | -SAME AS ABOVE-    | 90% - WITH 45 DAYS CREDIT WITHOUT ADDITIONAL BG. BALANCE 10% OF MATL COST WITH CREDIT 30 DAYS FROM THE DATE OF RECEIPT OF MATERIAL RECEIPT CERTIFICATE                                                                                   | 15% OF THE BASIC MATERIAL VALUE.                                                    |
|       |                  | -SAME AS ABOVE-    | 100% WITH 45 DAYS CREDIT WITHOUT ADDITIONAL BG                                                                                                                                                                                           | 17% OF THE 100% BASIC MATERIAL VALUE.                                               |
|       |                  | -SAME AS ABOVE-    | 75% WITH LESS THAN 45 DAYS CREDIT. BALANCE 10% OF MATL COST WITH CREDIT 30DAYS FROM THE DATE OF RECEIPT OF MATERIAL RECEIPT CERTIFICATE<br>BAL. 15% WITH CREDIT 30 DAYS FROM THE DATE OF RECEIPT OF COMMISSIONING COMPLETION CERTIFICATE | 1.5% OF THE 75% BASIC MATERIAL VALUE.                                               |
|       |                  | -SAME AS ABOVE-    | 90% WITH LESS THAN 45 DAYS CREDIT WITHOUT ADDITIONAL BG. BALANCE 10% OF MATL. COST WITH CREDIT 30 DAYS FROM THE DATE OF RECEIPT OF MATERIAL RECEIPT CERTIFICATE                                                                          | 16.35% OF THE BASIC MATERIAL VALUE (I.E. 15% +1.5% OF THE 90% BASIC MATERIAL VALUE) |



**Electronics Division, Bangalore RFQ No.: PKN0000031 DATED 23.12.2013**

| SL NO | COMMERCIAL TERMS | BHEL STANDARD TERM | IF YOU QUOTE                                                                                                                                                                                                                                                    | LOADING FACTOR FOR NON-COMPLIANCE OF BHEL STANDARD TERM                             |
|-------|------------------|--------------------|-----------------------------------------------------------------------------------------------------------------------------------------------------------------------------------------------------------------------------------------------------------------|-------------------------------------------------------------------------------------|
|       |                  | -SAME AS ABOVE-    | 100% WITH LESS THAN 45 DAYS CREDIT WITHOUT ADDITIONAL . BG.                                                                                                                                                                                                     | 26.5% OF THE BASIC MATERIAL VALUE (I.E. 25% +1.5% OF THE 100% BASIC MATERIAL VALUE) |
|       |                  | -SAME AS ABOVE-    | 75% THROUGH BANK. BALANCE 10% OF MATL COST WITH CRE DIT 30 DAYS FROM THE DATE OF RECEIPT OF MATERIAL RECEIPT CERTIFICATE BAL 15% WITH CREDIT 30 DAYS FROM THE DATE OF RECEIPT OF COMMISSIONING COMPLETION CERTIFICATE                                           | 10% OF THE 75% BASIC MATREIAL VALUE                                                 |
|       |                  | -SAME AS ABOVE-    | 90% THROUGH BANK. ALONGWITH BG FOR 15% OF THE BASIC MATERIAL VALUE VALID TILL COMPLETION OF COMMISSIONING APART FROM PBG 10% OF THE BASIC MATERIAL VALUE. BALANCE 10% OF MATL COST WITH CREDIT 30 DAYS FROM THE DATE OF RECEIPT OF MATERIAL RECEIPT CERTIFICATE | 10% OF THE 90% BASIC MATERIAL VALUE                                                 |
|       |                  | -SAME AS ABOVE-    | 100% THROUGH BANK. ALONGWITH BG FOR 25% OF THE BASIC MATERIAL VALUE VALID TILL COMPLETION OF COMMISSIONING APART FROM PBG 10% OF THE BASIC MATERIAL VALUE.                                                                                                      | OFFER WILL BE REJECTED                                                              |



**Electronics Division, Bangalore RFQ No.: PKN0000031 DATED 23.12.2013**

| SL NO | COMMERCIAL TERMS                                               | BHEL STANDARD TERM                                                                                                                                                                                                                                                                                                                                                                 | IF YOU QUOTE                                                                                                                                                               | LOADING FACTOR FOR NON-COMPLIANCE OF BHEL STANDARD TERM                          |
|-------|----------------------------------------------------------------|------------------------------------------------------------------------------------------------------------------------------------------------------------------------------------------------------------------------------------------------------------------------------------------------------------------------------------------------------------------------------------|----------------------------------------------------------------------------------------------------------------------------------------------------------------------------|----------------------------------------------------------------------------------|
|       |                                                                | -SAME AS ABOVE-                                                                                                                                                                                                                                                                                                                                                                    | 90% THROUGH BANK WITHOUT ADDITIONAL BG BALANCE 10% OF THE MATL COST WITH CREDIT 30 DAYS FROM THE DATE OF RECEIPT OF MATERIAL RECEIPT CERTIFICATE                           | 24% OF THE BASIC MATERIAL VALUE (I.E. 15% + 10% OF THE 90% BASIC MATERIAL VALUE) |
|       |                                                                | -SAME AS ABOVE-                                                                                                                                                                                                                                                                                                                                                                    | 100% THROUGH BANK WITHOUT ADDITIONAL BG                                                                                                                                    | OFFER WILL BE REJECTED                                                           |
| 2.    | <b>TERMS OF PAYMENT (WHERE SCOPE DOES NOT INCLUDE E&amp;C)</b> | a) 90% with 45 days credit from the date of receipt of complete set of original dispatch documents including Original Performance Bank Guarantee for 10% of the basic material value (if applicable) toBHEL. b) Balance 10% with 30 days credit from the date of receipt of materials at site and prof of supply of O&M manuals in required sets, against a supplementary Invoice. | 100% WITH 45 DAYS CREDIT ALONGWITH ADDITIONAL BG FOR 10% OF THE BASIC MATERIAL VALUE VALID TILL RECEIPT OF MATERIAL AT SITE APRT FROM PBG 10% OF THE BASIC MATERIAL VALUE. | NIL                                                                              |



**Electronics Division, Bangalore RFQ No.: PKN0000031 DATED 23.12.2013**

| SL. NO. | COMMERCIAL TERMS                                                                                                                                                                                                                                         | BHEL STANDARD TERM                                                                                                                                                 | IF YOU QUOTE                                                                                                                                                       | LOADING FACTOR FOR NON-COMPLIANCE TO BHEL STANDARD TERM                              |
|---------|----------------------------------------------------------------------------------------------------------------------------------------------------------------------------------------------------------------------------------------------------------|--------------------------------------------------------------------------------------------------------------------------------------------------------------------|--------------------------------------------------------------------------------------------------------------------------------------------------------------------|--------------------------------------------------------------------------------------|
|         |                                                                                                                                                                                                                                                          | -SAME AS ABOVE-                                                                                                                                                    | 100% WITH 45 DAYS CREDIT WITHOUT ADDITIONAL BG.                                                                                                                    | 10% OF THE 100% BASIC MATERIAL VALUE                                                 |
|         |                                                                                                                                                                                                                                                          | -SAME AS ABOVE-                                                                                                                                                    | 100% WITH LESS THAN 45 DAYS CREDIT WITHOUT ADDITIONAL BG.                                                                                                          | 11.5% OF THE BASIC MATERIAL VALUE (I.E. 10% + 1.5% OF THE 100% BASIC MATERIAL VALUE) |
|         |                                                                                                                                                                                                                                                          | -SAME AS ABOVE-                                                                                                                                                    | 90% THROUGH BANK BALANCE 10% OF MATL COST WITH CREDIT 30 DAYS OF CONSIGNEE RECEIPT CERTIFICATE                                                                     | 10% OF THE 90% BASIC MATERIAL VALUE                                                  |
|         |                                                                                                                                                                                                                                                          | -SAME AS ABOVE-                                                                                                                                                    | 100% THROUGH BANK ALONGWITH ADDITIONAL BG FOR 10% OF THE BASIC MATERIAL VALUE VALID TILL RECEIPT OF MATERIAL AT SITE APRT FROM PBG 10% OF THE BASIC MATERIAL VALUE | 10% OF THE 100% OF THE BASIC MATERIAL VALUE                                          |
|         |                                                                                                                                                                                                                                                          | -SAME AS ABOVE-                                                                                                                                                    | 100% THROUGH BANK WITHOUT ADDITIONAL BG.                                                                                                                           | 20% OF THE BASIC MATERIAL VALUE (I.E. 10% + 10% OF THE 100% BASIC MATERIAL VALUE)    |
|         | Note : Payment terms like (a) Advance (b) Inland L/C (c) Proforma Invoice (d) Against Exchange of dispatch documents (e) CAD i.e. Cash against documents and (f) High sea sales will not be accepted. It may lead to commercial rejection of your offer. |                                                                                                                                                                    |                                                                                                                                                                    |                                                                                      |
| B.      | FOR IMPORTED SCOPE OF SUPPLY :                                                                                                                                                                                                                           |                                                                                                                                                                    |                                                                                                                                                                    |                                                                                      |
|         | TERMS OF PAYMENT (WHERE SCOPE DOES NOT INCLUDE E&C)                                                                                                                                                                                                      | Against "SIGHT DAAFT" on presentation of dispatch documents to our Bankers. The payment terms are as follows: a) 90% of the FCA value is payable on negotiation of | 100% AGAINST SIGHT DARFT                                                                                                                                           | 10% OF THE 100% FCA VALUE.                                                           |

|   |                                                                                                                |                                                                                                                                                                                                                                                                                                                  |                 |                                                                                                                                                                                                                                               |                                                          |
|---|----------------------------------------------------------------------------------------------------------------|------------------------------------------------------------------------------------------------------------------------------------------------------------------------------------------------------------------------------------------------------------------------------------------------------------------|-----------------|-----------------------------------------------------------------------------------------------------------------------------------------------------------------------------------------------------------------------------------------------|----------------------------------------------------------|
|   |                                                                                                                | complete set of original documents including original Performance Bank Guarantee for 10% of the F CA value (if applicable), b)Balance 10% of the F CA value on 60th day from the date of Air Way Bill or Bill of Lading & against specific authorization by BHEL.                                                | -SAME AS ABOVE- | 90% THROUGH LETTER OF CREDIT. BALANCE 10% FOR THE F CA VALUE ON 60 <sup>TH</sup> DAY FROM THE DATE OF AIR WAY BILL OR BILL OF LADING & AGAINST SPECIFIC AUTHORISATION BY BHEL. ALL BANK CHARGES OUTSIDE INDIA TO BENEFICIARY'S A/C.           | 2.5% OF THE 100% F CA VALUE                              |
|   |                                                                                                                |                                                                                                                                                                                                                                                                                                                  |                 | Note : Payment terms like (a)Advance (b) Telegraphic transfer (T/T) (c) Confirmed L/C (d) CAD i.e. Cash against documents and may lead to commercial rejection of your offer.Offer with payment term as "100% through bank" will be rejected. | (e) <del>High sea sales will not be considered.</del> It |
| C | PENALTY FOR DELAY IN SUBMISSION OF DOCUMENTS FOR BHEL / CUSTOMER'S APPROVAL (COMMON FOR INDIGENOUS / IMPORTED) | In the event of delay in submission of complete Set of documents (including soft copy) in required sets beyond 2 week from receipt of Purchase Order (supplier to confirm date of PO in writing), penalty @ 2% (two percent) per week but limited to a max. of 10% (Ten percent) value of PO will be applicable. | -SAME AS ABOVE- | If not agreed.                                                                                                                                                                                                                                | 10% OF THE BASIC MATERIAL VALUE.                         |
|   |                                                                                                                |                                                                                                                                                                                                                                                                                                                  |                 | If max. 5% is agreed.                                                                                                                                                                                                                         | 5% OF THE BASIC MATERIAL VALUE.                          |
|   |                                                                                                                |                                                                                                                                                                                                                                                                                                                  |                 | If @ ½% (half percent) per week but limited to a max. of 10% (Ten percent) is agreed.                                                                                                                                                         | 7.5 % OF THE BASIC MATERIAL VALUE                        |
|   |                                                                                                                |                                                                                                                                                                                                                                                                                                                  |                 | If @ ¼% (half percent) per week but limited to a max. of 5% (Five percent) is agreed.                                                                                                                                                         | 10% OF THE BASIC MATERIAL VALUE.                         |
|   |                                                                                                                |                                                                                                                                                                                                                                                                                                                  |                 | If @ 1% (one percent) per week but limited to a max. of 10% (Ten percent) is agreed.                                                                                                                                                          | 5% OF THE BASIC MATERIAL VALUE.                          |
|   |                                                                                                                |                                                                                                                                                                                                                                                                                                                  |                 | If @ 1% (one percent) per week but limited to a max. of 5% (Five percent) is agreed.                                                                                                                                                          | 7.5 % OF THE BASIC MATERIAL VALUE.                       |
| D | PENALTY FOR DELAY IN DELIVERY (COMMON FOR                                                                      | In the event of delay in agreed contractual delivery, penalty @ 2% (two percent) per week                                                                                                                                                                                                                        | -SAME AS ABOVE- | IF NOT AGREED                                                                                                                                                                                                                                 | 10% OF THE BASIC MATERIAL VALUE.                         |

|   |                                                                          |                                                                                                                                                                                    |                                                                                                         |                                                                                                                                    |  |
|---|--------------------------------------------------------------------------|------------------------------------------------------------------------------------------------------------------------------------------------------------------------------------|---------------------------------------------------------------------------------------------------------|------------------------------------------------------------------------------------------------------------------------------------|--|
|   | INDIGENOUS / IMPORTED)                                                   | but limited to a max of 10% (Ten percent ) value of undelivered portion will be applicable.<br><br>-SAME AS ABOVE-                                                                 |                                                                                                         |                                                                                                                                    |  |
|   |                                                                          | -SAME AS ABOVE-                                                                                                                                                                    | if max. 5% is agreed.                                                                                   | 5% OF THE BASIC MATERIAL VALUE.                                                                                                    |  |
|   |                                                                          | -SAME AS ABOVE-                                                                                                                                                                    | if @ ½% (half percent) per week but limited to a max. of 10% (Ten percent) is agreed.                   | 7.5 % OF THE BASIC MATERIAL VALUE                                                                                                  |  |
|   |                                                                          | -SAME AS ABOVE-                                                                                                                                                                    | if @ ½% (half percent) per week but limited to a max. of 5% (Five percent) is agreed.                   | 10% OF THE BASIC MATERIAL VALUE.                                                                                                   |  |
|   |                                                                          | -SAME AS ABOVE-                                                                                                                                                                    | if @ 1% (one percent) per week but limited to a max. of 10% (Ten percent) is agreed.                    | 5% OF THE BASIC MATERIAL VALUE.                                                                                                    |  |
|   |                                                                          | -SAME AS ABOVE-                                                                                                                                                                    | if @ 1% (one percent) per week but limited to a max. of 5% (Five percent) is agreed.                    | 7.5 % OF THE BASIC MATERIAL VALUE.                                                                                                 |  |
| E | DELIVERY & PENALTY (COMMON FOR INDIGENOUS/IMPORTED)                      | Within ..... weeks from the date of issue of document approval or manufacturing clearance by BHEL.<br>(AS PER DELIVERY MENTIONED)                                                  | IF NOT AGREED FOR THE STIPULATED DELIVERY IN THE ENQUIRY (RFQ) BUT AGREED FOR PENALTY CLAUSE AS         | 2% PER WEEK UPTO MAX OF 10% OF THE BASIC MATERIAL VALUE FOR THE QUOTED DELIVERY BEYOND THE STIPULATED DELIVERY IN THE ENQUIRY.     |  |
|   |                                                                          | -SAME AS ABOVE-                                                                                                                                                                    | IF SPECIFIED DELIVERY IN ENQUIRY (RFQ) IS AGREED BUT PENALTY CLAUSE IS NOT AGREED.                      | 10% OF THE BASIC MATERIAL VALUE.                                                                                                   |  |
|   |                                                                          | -SAME AS ABOVE-                                                                                                                                                                    | IF SPECIFIED DELIVERY IN ENQUIRY (RFQ) IS AGREED & PENALTY CLAUSE IS AGREED BUT GRACE PERIOD IS SOUGHT. | 2% PER WEEK UPTO MAX OF 10% OF THE BASIC MATERIAL VALUE FOR THE QUOTED GRACE PERIOD BEYOND THE STIPULATED DELIVERY IN THE ENQUIRY. |  |
|   |                                                                          | -SAME AS ABOVE-                                                                                                                                                                    | IF BOTH DELIVERY & PENALTY NOT AGREED, AS PER BHEL TERMS.                                               | 10% OF THE BASIC MATERIAL VALUE PLUS 2% PER WEEK DELIVERY QUOTED BEYOND STIPULATED DELIVERY PERIOD                                 |  |
|   |                                                                          |                                                                                                                                                                                    | Note : Any delivery quoted beyond 5 weeks from the stipulated delivery, offer is liable for rejection.  |                                                                                                                                    |  |
| F | <del>PERFORMANCE BANK GUARANTEE (COMMON FOR INDIGENOUS / IMPORTED)</del> | <del>PBG for 10% of the basic material cost shall be furnished in the BHEL prescribed format only, along with 75 / 90% Invoice directly to the purchase dept. from the Bank.</del> | <del>IF NOT AGREED.</del>                                                                               | <del>10% OF THE BASIC MATERIAL VALUE.</del>                                                                                        |  |

|   |          |                                                                                                       |                                                                                                                                                   |                                                                          |
|---|----------|-------------------------------------------------------------------------------------------------------|---------------------------------------------------------------------------------------------------------------------------------------------------|--------------------------------------------------------------------------|
|   |          | <del>SAME AS ABOVE</del>                                                                              | <del>IF 5% IS AGREED</del>                                                                                                                        | <del>5% OF THE BASIC MATERIAL VALUE.</del>                               |
|   |          | <del>SAME AS ABOVE</del>                                                                              | OTHER THAN THE ABOVE                                                                                                                              | (10% MINUS THE AGREED MAX. %) OF THE BASIC MATERIAL VALUE WILL BE LOADED |
|   |          | <del>SAME AS ABOVE</del>                                                                              | <del>PBG for 10% of the basic material cost furnished in Supplier's standard format, along with 75 / 90% Invoice directly to Purchase Dept.</del> | <del>10% OF THE BASIC MATERIAL VALUE</del>                               |
| G | WARRANTY | 30 months from the date of despatch or 24 months from the date of commissioning whichever is earlier. | IF NOT AGREED FOR THE STIPULATED WARRANTY PERIOD IN THE ENQUIRY.                                                                                  | 0.5% OF THE BASIC MATERIAL VALUE PER MONTH FOR THE DIFFERENCE IN PERIOD. |



Electronics Division, Bangalore

**PROFORMA OF PERFORMANCE BANK GUARANTEE**  
**(FOR INDIGENOUS PURCHASE ORDERS)**

**ANNEXURE-II**

- Note :
- 1) To be executed in Rs. 200/- Non-Judicial stamp paper.
  - 2) To be submitted by issuing bank to purchase Dept. directly. Please give BHEL address to banker.
  - 3) Do not enclose with Bank document.
  - 4) Modification & Omissions to this are not permitted.
- 

**PERFORMANCE GUARANTEE**  
**(PROFORMA OF BANK GUARANTEE)**

THIS DEED OF GUARANTEE made and executed on the \_\_\_\_\_ day of \_\_\_\_\_ (year), by the \_\_\_\_\_ (Bank), registered under the Companies Act 1956/Nationalised Bank constituted under the Banking Companies (acquisition and transfer of undertakings) Act constituted under the State Bank of India Act / Subsidiary Banks, Act, having its registered / head office at \_\_\_\_\_ represented herein by its Branch Manager / authorised representatives Sri. \_\_\_\_\_ & Sri. \_\_\_\_\_ (Hereinafter called 'guarantor' which term shall mean and include its successors and assigns)

**IN FAVOUR OF BHARAT HEAVY ELECTRICALS LIMITED**

\_\_\_\_\_ (Buyer's Name), a company registered under the companies Act, 1956 having its registered office at BHEL House at Siri Fort, New Delhi-110 049 and its Electronics Division at Mysore Road, Bangalore - 26 (hereinafter referred to as the 'Company' Which term shall include its successors and assigns):

Whereas the company has placed an order on \_\_\_\_\_ (State the name of the company / firm and its address) (hereinafter referred to as the 'Supplier' which term shall mean and include its liquidators, successors and assign) for the supply of system under order / Contract No \_\_\_\_\_ Dt \_\_\_\_\_.

AND WHEREAS the supplier has agreed to supply the materials and carryout the works as detailed and in accordance with the terms set out in the said order / contract.





Electronics Division, Bangalore

**PROFORMA OF PERFORMANCE BANK GUARANTEE**  
**(FOR INDIGENOUS PURCHASE ORDERS)**

AND WHEREAS the company is not required to pay to the supplier a sum of Rupees \_\_\_\_\_ being the 10% of the value of the goods supplied / Works performed / Services rendered under the said order / contract between the supplier and the company, till the company is satisfied with the mechanical Warranties and the performance standards stipulated in the said order / contract between the company and the supplier has been duly fulfilled, except, against a Bank Guarantee for the said sum of Rs. \_\_\_\_\_ in favour of the company by reputed Bank, in which case the company has agreed to make payment to the supplier of the said sum of Rupees \_\_\_\_\_ being (.....%) of the value of the goods supplied / Works performed / Services rendered under the agreement between the supplier and the company and the Guarantor has at the request of the supplier, agreed to furnish this Guarantee subject to the terms and conditions stated below :

NOW THIS DEED WITNESSES THAT IN pursuance of the above said agreement, the guarantor hereby agrees and covenents with company is as follows:-

- 1) That during the period this contract of Guarantee remains effectual, the guarantor shall be liable in respect of the amount due and owing to the company in respect of the payments to the extent of Rs \_\_\_\_\_ (in words) \_\_\_\_\_ against any loss or damage caused to or suffered by the company by reasons of any breach of the terms of the said order / contract / Agreement by the supplier.
- 2) The Guarantor hereby undertakes to pay the amounts and payable under this guarantee without any demur, merely on demand from the company intimating that the amount claimed is due by way of loss or damage caused to or suffered or would be caused or suffered by the supplier of any terms contained in the said order / contract. Any such demand made on the guarantor shall be conclusive as regards the amount due and payable by the Guarantor irrespective of the fact whether the Contractor / supplier admits or denies.
- 3) The Guarantor further agrees that the agreement herein contained shall remain in force and effect till all the supplies to be made / Works to be performed/Services to be rendered under the said order / contract / agreement are completed to the entire satisfaction of the company or till company certifies that the terms and conditions of the said order / contract / agreement have been fully and properly carried out by the said supplier and accordingly



Electronics Division, Bangalore

**PROFORMA OF PERFORMANCE BANK GUARANTEE**  
**(FOR INDIGENOUS PURCHASE ORDERS)**

discharges the Guarantee. Unless a demand or claim under this guarantee is made on the guarantor in writing on or before the expiry of claim period indicated in clause 6 below, the guarantor shall be discharged from all the liability under this guarantee thereafter.

- 4) The guarantor further agrees with the company that the company shall have the fullest liberty without the consent of the guarantor and without effecting in any manner the obligations of the guarantor hereunder to vary any of the terms of the said order / contract / agreement or extend the time of performance by the said supplier from time to time or refrain from exercising the power exercisable by the company against the said supplier or to forebear or omit to enforce any of the terms and conditions relating to the said order / contract / agreement, and the guarantor shall not be relieved of its liability in whole or in part, by reason of any act, commission or forbearance on the part of the company or by reason of any such variation, or extension being granted to the said supplier or by reason of any such matter or thing whatsoever which under the law relating to sureties would but for this provision have effect of so relieving the guarantor.
- 5) The guarantor undertakes not to revoke this guarantee during its currency except with the previous consent of the company in writing.
- 6) Notwithstanding anything herein above obtained, the liability of the guarantor under these presents is restricted to Rs.\_\_\_\_\_. The guarantee shall be in force till its expiry on \_\_\_\_\_ unless a demand is made on the guarantor within SIX months from the date of expiry, all the liability of the guarantor under this guarantee shall stand fully discharged. The decision of the claimant in regard to breach of contract is final and binding on the Bank.

IN WITNESS whereof, the guarantor, acting through its authorised representative has executed this deed of Guarantee on the day, month and year first above written.

(Seal of the Bank to be affixed)

WITNESS

1.

2.



Electronics Division, Bangalore

**PROFORMA OF PERFORMANCE BANK GUARANTEE**  
**(FOR FOREIGN PURCHASE ORDERS)**

**ANNEXURE-III (a)**

---

**BANK NAME AND ADDRESS**

Electronic Division  
Bharat Heavy Electricals Limited, (B.H.E.L.)  
Mysore Road, P.B. No. 2606  
BANGALORE - 560 026

Dear Sir,

Ref : CONTRACT PERFORMANCE GUARANTEE.

WHEREAS you have entered into a contract reference No & PO NO. \_\_\_\_\_  
Date \_\_\_\_\_ with M/s \_\_\_\_\_ having its registered office  
at \_\_\_\_\_ for the supply of \_\_\_\_\_ as detailed in your  
purchase order No. \_\_\_\_\_ which is hereinafter referred to as "the said contract"  
and WHEREAS M/s \_\_\_\_\_ has undertaken to produce a Bank  
Guarantee for 10% (Tern Percent) of the contract price amounting to \_\_\_\_\_  
( \_\_\_\_\_ ) to secure its obligatios to Electronics Division,  
BHEL having its registered office at New Delhi for the performance of the contract including  
the warranty of the equipment supplied, We \_\_\_\_\_  
Bank, \_\_\_\_\_ hereby expressly, irrevocably and unreservedly  
undertake and guarantee as principal obligors on behalf of M/s \_\_\_\_\_  
that in the even Bharat Heavy Electricals Ltd. (B.H.E.L.) declares to us in writing that  
M/s \_\_\_\_\_ has not fulfilled any obligation according to the  
contractual obligation of the said contract, to pay you on demand and without demur to Bharat  
Heavy Electricals Ltd., Electronics Division, Mysore Road, P.B.No. 2606, Bangalore - 560 026.,  
India an amount of \_\_\_\_\_  
(in words \_\_\_\_\_ )  
subject to as may be determined below :



Electronics Division, Bangalore

**PROFORMA OF PERFORMANCE BANK GUARANTEE**  
**(FOR FOREIGN PURCHASE ORDERS)**

- 
- 1) Notwithstanding any right M/s. \_\_\_\_\_ may have directly against you or any disputes raised by M/s \_\_\_\_\_  
\_\_\_\_\_, Your written demand shall be conclusive evidence to us that repayment is due under the terms of the said contract and shall be binding on us.
  - 2) We shall not be discharged or released from this undertaking and Guarantee by any arrangements, variations made between you and M/s. \_\_\_\_\_ with or without our consent and Knowledge or by any alteration in the obligations of M/s. \_\_\_\_\_ by any forbearance whether as to payment, time, performance or otherwise.
  - 3) This guarantee shall remain valid until the end of six months after the close of the warranty period or until the same is reported by BHEL to us whichever is earlier.
  - 4) We agree and undertake not to revoke this guarantee during its validity unless discharged in writing by you subject to the provision of clause (7) below :
  - 5) This guarantee shall be a continuing guarantee subject to the foregoing and shall not be discharged by any change in the constitution of the Bank or M/s. \_\_\_\_\_.
  - 6) This guarantee shall be governed by and constructed in accordance with the Laws of India.
  - 7) At any time \_\_\_\_\_ Bank may render this guarantee null and void by paying to Bharat Heavy Electricals Ltd. the full amount being \_\_\_\_\_ ( in words \_\_\_\_\_ )  
\_\_\_\_\_ )

For and on behalf of Bank  
by its Authorised Signatory

**ANNEXURE - III( b)**

**INSTRUCTIONS FOR PBG SUBMISSION**

**SUB : POINTS TO BE COMPILED FOR THE SUBMISSION OF BANK GUARANTEES /**  
**PERFORMANCE BANK GUARANTEES**

Pursuant to the guidelines issued by BHEL corporate office and CVC the following points are to be taken care of during submission of BGs/PBGs. These conditions will be incorporated in the purchase orders :

- \* **BGs/PBGs of PSU banks in addition to BHEL consortium banks are only acceptable. List of BHEL Consortium Banks Enclosed.**
- \* **In case of BGs/PBGs issued by non consortium PSU banks the same are to be enforceable in Bangalore.**
- \* **In case of BGs/PBGs issued by Foreign banks the same to be confirmed by BHEL consortium bank in India.**
- \* **It is insisted upon that BGs/PBGs issued by issuing bank on behalf of your company should be sent to BHEL EDN directly by the issuing bank under Registered Post (AD) with a covering letter of bank indicating contact no., fax no., E-mail ID, issuing officer name, address of the issuing bank etc.**
- \* **Please ask the banker to post original PBG directly to : (Executive referred in PO)**  
**DGM/Purchase, Purchase Dept., NEB IIInd (second) Floor, BHEL, Electronics Division, Mysore Road, Bangalore - 560 026, Ph : 080 26989191**
- \* **We will not accept any BGs/PBGs from your office directly. In case you collect BGs/PBGs from issuing bank and send to us, the same will be returned back to your office.**
- \* **Expired BGs/PBGs will be returned after the expiry of the guarantee period including claim period or upon fulfillment of the relevant contract whichever is earlier.**
- \* **Please give Purchase dealing Executive name, postal address, P.O. No., tel ph no. to bank and insist bank to write these details on the envelope.**

**Electronics Division, Bangalore****Annexure-III (c)****BHEL MEMBER BANKS (LIST OF CONSORTIUM BANKS)****PBG SHALL BE ISSUED FROM THE FOLLOWING 22 BANKS ONLY:**

|    |                                                    |
|----|----------------------------------------------------|
| 1  | State Bank of India                                |
| 2  | Deutsche Bank AG                                   |
| 3  | Canara Bank                                        |
| 4  | HDFC Bank Ltd.,                                    |
| 5  | Punjab National Bank                               |
| 6  | CITI Bank NA,                                      |
| 7  | Bank of Baroda                                     |
| 8  | Standard Chartered Bank,                           |
| 9  | State Bank of Hyderabad                            |
| 10 | ICICI Bank Ltd.                                    |
| 11 | The Hongkong and Shanghai Banking Corporation Ltd. |
| 12 | IDBI Bank Ltd.                                     |
| 13 | State Bank of Tranvancore                          |
| 14 | Corporation Bank                                   |
| 15 | Kotak Mahindra Bank Ltd.                           |
| 16 | ABN AMRO Bank N.V.                                 |
| 17 | Syndicate Bank                                     |
| 18 | Indian Bank                                        |
| 19 | Oriental Bank Of Commerce                          |
| 20 | UCO Bank                                           |
| 21 | Central Bank of India                              |
| 22 | The Federal Bank Ltd.                              |

**Please Note :** It is preferable if PBG is obtained from BHEL consortium Banks listed above. BHEL may accept PBG from other Nationalised Banks also which are not listed above. PBG will not be accepted from scheduled Banks and Co-operative Banks.

## **ANNEXURE-IV**

### **Terms & Conditions of Reverse Auction**

Against this enquiry for the subject item/ system with detailed scope of supply as per enquiry specifications, BHEL may resort to “REVERSE AUCTION PROCEDURE” i.e., ON LINE BIDDING (THROUGH A SERVICE PROVIDER). The philosophy followed for reverse auction shall be English Reverse (No ties).

1. For the proposed reverse auction, technically and commercially acceptable bidders only shall be eligible to participate.
2. Those bidders who have given their acceptance for Reverse Auction (quoted against this tender enquiry) will have to necessarily submit “online sealed bid” in the Reverse Auction. Non-submission of “online sealed bid” by the bidder for any of the eligible items for which techno-commercially qualified, will be considered as tampering of the tender process and will invite action by BHEL as per extant guidelines in vogue.
3. BHEL will engage the services of a service provider who will provide all necessary training and assistance before commencement of on line bidding on internet.
4. In case of reverse auction, BHEL will inform the bidders the details of Service Provider to enable them to contact & get trained.
5. Business rules like event date, time, bid decrement, extension etc. also will be communicated through service provider for compliance.
6. Bidders have to fax the Compliance form (annexure IV) before start of Reverse auction. Without this, the bidder will not be eligible to participate in the event.
7. In line with the NIT terms, BHEL will provide the calculation sheet (e.g., EXCEL sheet) which will help to arrive at “Total Cost to BHEL” like Packing & forwarding charges, Taxes and Duties, Freight charges, Insurance, Service Tax for Services and loading factors (for non-compliance to BHEL standard Commercial terms & conditions) for each of the bidder to enable them to fill-in the price and keep it ready for keying in during the Auction.
8. Reverse auction will be conducted on scheduled date & time.
9. At the end of Reverse Auction event, the lowest bidder value will be known on auction portal.

10. The lowest bidder has to fax/e-mail the duly signed and filled-in prescribed format for price breakup including that of line items, if required, (Annexure VII) as provided on case-to-case basis to Service provider within two working days of Auction without fail.

11. In case BHEL decides not to go for Reverse Auction procedure for this tender enquiry, the Price bids and price impacts, if any, already submitted and available with BHEL shall be opened as per BHEL's standard practice.

12. Bidders shall be required to read the "Terms and Conditions" section of the auctions site of Service provider, using the Login IDs and passwords given to them by the service provider before reverse auction event. Bidders should acquaint themselves of the "Business Rules of Reverse Auction", which will be communicated before the Reverse Auction.

13. If the Bidder or any of his representatives are found to be involved in Price manipulation/ cartel formation of any kind, directly or indirectly by communicating with other bidders, action *as per extant BHEL guidelines*, shall be initiated by BHEL and the results of the RA scrapped/ aborted.

14. The Bidder shall not divulge either his Bids or any other exclusive details of BHEL to any other party.

15. In case BHEL decides to go for reverse auction, the H1 bidder(s) (whose quote is highest in online sealed bid) may not be allowed to participate in further RA process.

**-X-X-**



**Electronics Division, Bangalore****ANNEXURE- V****LIST OF INTERNATIONAL AIRPORTS.**

| <b>SNo</b> | <b>Country</b> | <b>Air Ports</b>                                                                                          |
|------------|----------------|-----------------------------------------------------------------------------------------------------------|
| 1          | Austria        | Vienna, Linz, Graz.                                                                                       |
| 2          | Australia      | Sydney, Melbourne, Perth                                                                                  |
| 3          | Belgium        | Antwerp, Brussels                                                                                         |
| 4          | Canada         | Toronto, Montreal                                                                                         |
| 5          | China          | Shangai.                                                                                                  |
| 6          | Cyprus         | Larnaca.                                                                                                  |
| 7          | Czech Republic | Prague (Via Frankfurt)                                                                                    |
| 8          | Denmark        | Copenhagen                                                                                                |
| 9          | Egypt          | Cairo                                                                                                     |
| 10         | Finland        | Helsinki                                                                                                  |
| 11         | France         | Paris (Roissy), Lyon                                                                                      |
| 12         | Germany        | Darmstadt, Manihem, Nurnberg, Hamburg, Stuttgart, Munich, Koln, Dusseldorf & Hannover, Frankfurt, Berlin. |
| 13         | Hongkong       | Hongkong                                                                                                  |
| 14         | Italy          | Rome, Milan, Turin, Bologna, Florence                                                                     |
| 15         | Ireland        | Dublin                                                                                                    |
| 16         | Isrel          | Telaviv.                                                                                                  |
| 17         | Japan          | Tokyo, Osaka                                                                                              |
| 18         | Malaysia       | Kaulalampur, Penang                                                                                       |
| 19         | Netherlands    | Amsterdam, Rotterdam                                                                                      |
| 20         | Newzealand     | Auckland                                                                                                  |
| 21         | Norway         | Oslo                                                                                                      |
| 22         | Oman           | Muscat                                                                                                    |
| 23         | Philiphines    | Manila                                                                                                    |
| 24         | Romania        | Bucharest                                                                                                 |
| 25         | Russia         | Moscow                                                                                                    |
| 26         | Saudi Arabia   | Riyad.                                                                                                    |
| 27         | Singapore      | Singapore                                                                                                 |
| 28         | Slovakia       | Bartislowa.                                                                                               |

**Electronics Division, Bangalore****LIST OF INTERNATIONAL AIRPORTS.**

| <b>SNo</b> | <b>Country</b> | <b>Air Ports</b>                                                                                                               |
|------------|----------------|--------------------------------------------------------------------------------------------------------------------------------|
| 29         | South Africa   | Johannesburg, Durban.                                                                                                          |
| 30         | South Korea    | Kimpo                                                                                                                          |
| 31         | Spain          | Barcelona                                                                                                                      |
| 32         | Sweden         | Stockholm, Gothenburg, Milano                                                                                                  |
| 33         | Switzerland    | Basle, Zurich, Geneva                                                                                                          |
| 34         | Taiwan         | Taipei                                                                                                                         |
| 35         | U.A.E          | Dubai                                                                                                                          |
| 36         | U.K            | London (Heathrow), Newcastle, Oxford, Cheltham, Bristol, Wellingborough, Birmingham, East Midland, Manchester, Leeds, Glasgow. |
| 37         | U.S.A          | Newyork, Chicago, Sanfrancisco, Los Angeles, Atlanta                                                                           |
| 38         | Ukraine        | Kiev                                                                                                                           |

## ANNEXURE - VI

### **PRESENT PROCEDURE FOR SALE IN TRANSIT (HIGH SEA SALES)**

1. DATE OF THE STAMP PAPER SHOULD BE PRIOR TO THE AIR WAY BILL / BILL OF LADING DATE. STAMP PAPER VALUE SHALL BE IN RS.200/- NON JUDICIAL PAPER.
2. SALE AGREEMENT IN RS. 200/- STAMP PAPER AND NOTARISED WITH 2 WITNESSES HAS TO BE SIGNED BETWEEN BHEL AND THE PARTY IMPORTING MATERIAL AND THE DATE OF THE SALE DOCUMENTS SHOULD BE IN BETWEEN THE DATE OF HOUSE AIR WAY BILL / BILL OF LADING AND BEFORE LANDING OF THE GOODS IN INDIAN ORIGIN.
3. THE SALE AGENTS SHOULD DULY ENDORSE HOUSE AIR WAY BILL (HAWB) FOR AIR SHIPMENTS OR ORIGINAL BILL OF LADING (O.B.L.) FOR SEA SHIPMENTS, DELIVERY ORDER AND FOREIGN CURRENCY INVOICE IN FAVOUR OF BHEL-EDN.
4. SELLER SHOULD GIVE FOREIGN CURRENCY INVOICE FROM THE ORIGINAL CONSIGNOR. THE FOREIGN CURRENCY INVOICE VALUE SHOULD BE AT LEAST 2% (TWO PER CENT) LESS THAN THE INDIGENOUS RUPEE INVOICE VALUE IN EQUIVALENT FOREIGN CURRENCY.
5. SELLER SHOULD ALSO GIVE LETTER OF AUTHORISATION TO AIR CONSOL AGENTS FOR RELEASING DELIVEY ORDERS TO BHEL-EDN.
6. SELLER PARTY SHOULD ALSO GIVE A LETTER TO THE COMMISSIONER OF CUSTOMS FOR EFFECTING ABOVE SALE.
7. SELLING PARTY SHOULD ALSO GIVE A LETTER TO THE DEPUTY ASSESSOR (OCTROI) FOR EFFECTING ABOVE SALE IN FAVOUR OF BHEL.
8. DESCRIPTION OF ITEM (NOMENCLATURE), UNIT & QUANTITY IN BOTH FOREIGN CURRENCY & THE RUPEE INVOICE IN RUPEE SHALL BE EXACTLY AS PER PO DESCRIPTION OF ITEM, QUANTITY AND UNIT. THE INDIGENOUS INVOICE VALUE SHALL BE EXACTLY AS PER PO VALUE.
9. PRICES SHOULD BE C.I.F., MUMBAI BASIS.
10. I.E.C., C.S.T., K.S.T. NOS. TO BE MENTIONED.
11. NOTE: THE FOLLOWING SHALL BE INCLUDED IN THE HIGH SEA SALES AGREEMENT:

**"THE BUYER ALSO UNDERTAKE DISCHARGES, THE OBLIGATION AND FULFILLMENT OF CONDITIONS, IF ANY, ATTACHED TO THE IMPORTATION, ASSESSMENT AND CLEARANCE OF THE GOODS IN TERMS CUSTOMS TARIFF ACT 1975, THE CUSTOMS ACT 1962 & RULES & REGULATIONS MADE THEREUNDER AND OTHER RELEVANT ACTS, ORDERS, NOTIFICATIONS".**

**REMARKS: IN CASE VENDOR NEEDS ANY CALRIFICATIONS ON THE ABOVE, THE SAME MAY BE SOUGHT IN WRITING.**

# REQUEST FOR QUOTATION

|                                                                                                    |                                                                                                                         |                                                            |                                                                                    |
|----------------------------------------------------------------------------------------------------|-------------------------------------------------------------------------------------------------------------------------|------------------------------------------------------------|------------------------------------------------------------------------------------|
| <br>MMI:PU:RF:003 | <b>BHARAT HEAVY ELECTRICALS LIMITED</b><br>Electronics Division<br>PB No. 2606, Mysore Road Bangalore - 560026<br>INDIA | RFQ NUMBER:<br>PKN0000031<br><br>RFQ DATE :<br>23.DEC.2013 | Due Date<br><b>24.JAN.2014</b><br>Time: 13:00 HRS<br><br>VENUE :<br>NEW ENGG. BLDG |
|----------------------------------------------------------------------------------------------------|-------------------------------------------------------------------------------------------------------------------------|------------------------------------------------------------|------------------------------------------------------------------------------------|

(for all correspondence)  
 Purchase Executive : P.K Nagaraj  
 Phone : 2699 8179  
 Fax : 080 2698 9227  
 E-mail: nagarajpk@bheledn.co.in

Please submit your lowest quotation subject to our terms and conditions attached for the material mentioned below. The quotation must be enclosed in a sealed envelope / Fax superscribed with RFQ no.and due date, should reach us on or before the due date by **13.00** hours IST and will be opened on the same day

| SI No. | Description                                                                             | Qty | Unit | Delivery qty | Delivery Date          |
|--------|-----------------------------------------------------------------------------------------|-----|------|--------------|------------------------|
| 1      | PR0280000170 Conductivity Analyser<br>Conductivity Analyser<br>Test Certificate         | 251 | NO   | 251          | <del>31.MAR.2014</del> |
| 2      | PR0280000189 pH Analyser<br>pH Analyser<br>Test Certificate                             | 157 | NO   | 157          | <del>31.MAR.2014</del> |
| 3      | PR0280000197 Dissolved Oxygen Analyser<br>Dissolved Oxygen Analyser<br>Test Certificate | 60  | NO   | 60           | <del>31.MAR.2014</del> |
| 4      | PR0280000200 Silica Analyser<br>Silica Analyser<br>Test Certificate                     | 23  | NO   | 23           | <del>31.MAR.2014</del> |
| 5      | PR0280000219 Sodium Analyser<br>Sodium Analyser<br>Test Certificate                     | 16  | NO   | 16           | <del>31.MAR.2014</del> |
| 6      | PR0280000227 Hydrazine Analyser<br>Hydrazine Analyser<br>Test Certificate               | 11  | NO   | 11           | <del>31.MAR.2014</del> |
| 7      | PR0280000235 Chloride Analyser<br>Chloride Analyser<br>Test Certificate                 | 6   | NO   | 6            | <del>31.MAR.2014</del> |
| 8      | PR0280000251 Phosphate Analyser<br>Phosphate Analyser<br>Test Certificate               | 12  | NO   | 12           | <del>31.MAR.2014</del> |
| 9      | PR0900003502 Ammonia Analyser<br>Ammonia Analyser for SWAS                              | 3   | NO   | 3            | <del>31.MAR.2014</del> |

Total Number of Items - **9**

Please note that the tender will be opened in the presence of the bidders or his authorised representatives (maximum two per organisation) who choose to be present with authorisation letters. Refer annexure for the terms and conditions.

Please specify Terms of delivery, Excise duty, sales tax, Ex-BHEL, Ex-works surcharge, Insurance,P&F, Freight and other taxes very clearly .

The offers of the bidders who are on the banned list as also the offer of the bidders, who engage the services of the banned firms, shall be rejected.The list of banned firms is available on BHEL web site [www.bhel.com](http://www.bhel.com)

- i). This is only RFQ not an order.
- ii). In all correspondence quote RFQ No. & due date.
- iii). In Quotation BHEL material code / RFQ SI. No. should be mentioned clearly.
- iv). Quotation Envelope / Fax not superscribed with RFQ No.and due date is liable for rejection.

In case of non-receipt of Quotation or regret letter for 3 consecutive RFQs you are liable to be removed from our



(\*) As per sec SI.No.1

For and On behalf of BHEL.

# REQUEST FOR QUOTATION

|                                                                                                                                                                                                                                                                                                                            |                                                                                                                                             |                                                                          |                                                                                                                |
|----------------------------------------------------------------------------------------------------------------------------------------------------------------------------------------------------------------------------------------------------------------------------------------------------------------------------|---------------------------------------------------------------------------------------------------------------------------------------------|--------------------------------------------------------------------------|----------------------------------------------------------------------------------------------------------------|
|                                                                                                                                                                                                                                           | <b>BHARAT HEAVY ELECTRICALS LIMITED</b><br>Electronics Division<br>PB No. 2606, Mysore Road Bangalore - 560026<br>INDIA                     | <b>RFQ NUMBER:</b><br>PKN0000031<br><br><b>RFQ DATE :</b><br>23.DEC.2013 | <b>Due Date</b><br><b>24.JAN.2014</b><br><b>Time: 13:00 HRS</b><br><br><b>VENUE :</b><br><b>NEW ENGG. BLDG</b> |
| MMI:PU:RF:003                                                                                                                                                                                                                                                                                                              | (for all correspondence)<br>Purchase Executive : P.K Nagaraj<br>Phone : 2699 8179<br>Fax : 080 2698 9227<br>E-mail: nagarajpk@bheledn.co.in |                                                                          |                                                                                                                |
| Please submit your lowest quotation subject to our terms and conditions attached for the material mentioned below. The quotation must be enclosed in a sealed envelope / Fax superscribed with RFQ no.and due date, should reach us on or before the due date by <b>13.00</b> hours IST and will be opened on the same day |                                                                                                                                             |                                                                          |                                                                                                                |
| venders list.<br>vii). All Prices should be written in words and numbers.<br>viii). Excise Chapter Heading should be mentioned for all items where VAT is applicable .                                                                                                                                                     |                                                                                                                                             |                                                                          |                                                                                                                |

For and On behalf of BHEL.

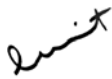
|                                                                                                                                                                                                                                                                                                                                                             |  |                                                                                                                                  |                                                                                                                          |                                                          |
|-------------------------------------------------------------------------------------------------------------------------------------------------------------------------------------------------------------------------------------------------------------------------------------------------------------------------------------------------------------|--|----------------------------------------------------------------------------------------------------------------------------------|--------------------------------------------------------------------------------------------------------------------------|----------------------------------------------------------|
|                                                                                                                                                                                                                                                                                                                                                             |  |  <p>बि एच ई एल<br/>A4-10</p>                    |                                                                                                                          | <b>CE/416/SWAS/ANALYSER/PS</b>                           |
|                                                                                                                                                                                                                                                                                                                                                             |  |                                                                                                                                  |                                                                                                                          | <b>REV NO : 00</b>                                       |
|                                                                                                                                                                                                                                                                                                                                                             |  |                                                                                                                                  |                                                                                                                          | <b>Page 1 of 14</b>                                      |
| <p style="writing-mode: vertical-rl; transform: rotate(180deg);">COPY RIGHT AND CONFIDENTIAL</p> <p style="writing-mode: vertical-rl; transform: rotate(180deg);">The information on this document is the property of Bharat Heavy Electrical Limited. It must not be used directly or indirectly in anyway detrimental to the interest of the company.</p> |  |                                                                                                                                  |                                                                                                                          |                                                          |
|                                                                                                                                                                                                                                                                                                                                                             |  | <b>PURCHASE SPECIFICATION<br/>FOR</b>                                                                                            |                                                                                                                          |                                                          |
|                                                                                                                                                                                                                                                                                                                                                             |  | <b>SWAS ANALYSERS</b>                                                                                                            |                                                                                                                          |                                                          |
|                                                                                                                                                                                                                                                                                                                                                             |  |                                                                                                                                  |                                                                                                                          |                                                          |
|                                                                                                                                                                                                                                                                                                                                                             |  | <b>APPROVED BY</b><br><br><b>(R.PRABHU)</b> |                                                                                                                          |                                                          |
|                                                                                                                                                                                                                                                                                                                                                             |  |                                                                                                                                  | <b>PREPARED BY</b><br><br><b>PPS</b> | <b>ISSUED</b><br><br><b>415</b><br><br><b>18-10-2013</b> |



**PURCHASE SPECIFICATION  
FOR  
SWAS ANALYSERS**

CE/416/SWAS/ANALYSER/PS  
REV.NO.: 00  
Page 2 of 14

---

**CONTENTS**

| SECTION | DESCRIPTION                               |
|---------|-------------------------------------------|
| A       | GENERAL INSTRUCTIONS TO BIDDERS           |
| B       | PRE-QUALIFICATION REQUIREMENTS            |
| C       | SCOPE OF SUPPLY FOR SWAS ANALYSERS        |
| D       | TECHNICAL REQUIREMENTS FOR SWAS ANALYSERS |
| E       | LIST OF MANDATORY SPARES                  |
| F       | PACKING STANDARD                          |

---



**PURCHASE SPECIFICATION  
FOR  
SWAS ANALYSERS**

CE/416/SWAS/ANALYSER/PS  
REV.NO.: 00  
Page 3 of 14

---

**SECTION-A**

**GENERAL INSTRUCTIONS TO BIDDERS:**

- 1.0 ALL REQUIRED DOCUMENTS AGAINST THIS TENDER/SPECIFICIFICATION SHALL BE SUBMITTED IN ENGLISH ONLY.
  - 2.0 Introduction: Bidders are required to offer Analysers used for SWAS in Power Plant applications.
  - 3.0 In order to accept the Technical offers / proposals from Bidders for the project mentioned in this Specification ( refer Sections C & D ), certain Pre-qualification criteria are required to be met by Bidder.
  - 4.0 Pre-qualification requirements are clearly mentioned in Section-B of this Specification. Bidder to read the same carefully and submit the details required for BHEL's acceptance.
  - 5.0 In case Bidder does not include the details or meet the requirements of Pre-qualification requirements, their offer will be summarily rejected and Bidder's Technical offers will not be evaluated.
  - 6.0 Evaluation methodology : BHEL shall initially open Bidder's PQR documents only as per Section B of this specification for review & acceptance. Only after acceptance of PQR documents, BHEL shall open Bidder's Technical offers as per CI 2.0 of above for evaluation. In the event of acceptance of Bidder's technical offers, the names of such Bidders along with details provided by them for PQR and details of Technical offers , shall be submitted to Endusers/Customers for their acceptance/approval. Commercial bids of only accepted/approved Bidders by Endusers/Customers, shall be considered by BHEL for further processing.
  - 7.0 Bidders are required to submit offers as detailed below :
    - aa. Documents pertaining to Pre-Qualification requirement ( CI AA of Section B of this Specification) shall be in a Separate cover with reference no. " CI AA of Section B" marked on it.
    - bb. Documents pertaining to Pre-Qualification requirement ( CI BB of Section B of this Specification) shall be in a Separate cover with reference no "CI BB of Section B" marked on it.
    - cc. Technical offers/proposals for the Project, whose requirements are mentioned in Sections C &D will be submitted in a separate cover with Project name & Reference marked on it.
  - 8.0 Whenever required during evaluation of PQR and Technical offers/bids, vendor is required to be present at BHEL Electronic Division, Bangalore, for discussions. Further in the event of order, during approval of the Vendor documents by End users/Customers, Vendor shall accompany BHEL representative for discussions.
-





**PURCHASE SPECIFICATION  
FOR  
SWAS ANALYSERS**

CE/416/SWAS/ANALYSER/PS  
REV.NO.: 00  
Page 4 of 14

---

**SECTION- B**

**AA. Pre-Qualification Requirements (PQR) of Bidders for SWAS Analyser:**

1. The bidder should have executed/ completed work of “Design, supply, supervision of erection & commissioning of complete SWAS package in 200 MW or above capacity for at least 2 units of SWAS within preceding three (3) years as on the date of bid opening.
  2. Original Equipment Manufacturers based outside India, who are making offer for this tender shall have authorized representatives in India for support related to Documentation, Erection, Commissioning & any other co-ordination work.
  3. Submit Reference List of Projects wherein offered system is supplied & commissioned, along with details of analyzers. If bidder is offering a combination of makes, PQR of respective OEMs shall be considered for evaluation.
  4. For Vendors offering upgraded / latest models, PQR of equivalent previous models is acceptable. OEM shall certify that offered model is upgraded version of previous existing model.
  5. OEM shall furnish an undertaking that in case of change in Indian representative / agent, OEM shall continue to support supplies w.r.t to field service, supply of reagents and spare parts
  6. For analyzers Bidder should be authorized and he should have capacity to commission the analyzers all across the country. The bidder should have the team of experienced service engineers on pay role located at various parts of INDIA. (With documentary evidence).
  7. Bidder shall have optimum inventory of critical components like analyser sensors/ electronic modules.
  8. Bidders shall provide the operating parameters like sample flow, pressure and temperature requirement for correct functioning of the offered analysers. Bidders shall confirm that Analysers shall function with Sample Handling System(SHS) procured from any vendor meeting above sample requirements.
  9. BHEL shall issue call for service / commissioning with 15 days notice. Bidder shall agree to visit BHEL project sites jointly with SHS vendors within above notice period.
-



**PURCHASE SPECIFICATION  
FOR  
SWAS ANALYSERS**

CE/416/SWAS/ANALYSER/PS  
REV.NO.: 00  
Page 5 of 14

---

**BB. Along with the documents related to PQR above, following details shall also be included in the Offer:**

1. Technical literature / Manuals of offered Analysers, Sensors.
2. In the event of technical specification not indicated in Technical literature, confirmation from OEM is acceptable. Such confirmations shall be supported by type test certificates.
3. Un priced Purchase Order copies
4. Reports of successful erection & commissioning Protocols & Minutes of the meetings for handing over of SWAS analysers.
5. Submit List of Projects ( rating of > or = 200 MW Power Plants ) for which Erection & Commissioning has been carried out by Subsidiary / Authorized Indian representative for last three year & minimum three system.
6. Name & registered address of the Indian branch office or Indian representative for support of E&C and after sales service with Organization chart.
7. Bidder shall have facility in India for Engineering activities, preparation of Documents, trouble shooting and calibration of analysers. Submit these details.
8. If Bidder is not Original Equipment Manufacturer (OEM), than Bidder to include Authorization letter from OEM for Design, Engineering, Manufacture, Testing, supply, Erection, Commissioning and Servicing of the offered System. This Authorization letter provided by OEM to Bidder shall indicate the Type and Duration of the agreement.

Important note : In case Bidder does not submit details mentioned in above clauses or meet the requirements of Pre-qualification requirements, Offers will be summarily rejected and Bidder's Technical offers/proposals will not be Evaluated. Please read carefully the General instructions in Section A of this specifications.

---



**PURCHASE SPECIFICATION  
FOR  
SWAS ANALYSERS**

CE/416/SWAS/ANALYSER/PS  
REV.NO.: 00  
Page 6 of 14

**SECTION- C**

**SCOPE OF SUPPLY FOR SWAS ANALYSERS**

SWAS analysers shall be supplied as per scope below:-

1. Analysers consisting of following:-
  - a. Conductivity (Specific ,Cation & Hotwell) - 251 Nos.
  - b. Dissolved Oxygen - 60 Nos.
  - c. Hydrazine - 11 No.
  - d. pH - 157 Nos.
  - e. Phosphate - 12 No.
  - f. Silica ( Three Channel ) - 23 No.
  - g. Chloride Analyser - 06 No.  
Sodium Analyser (Three channel)- 16 No.
  - h. Ammonia Analyser – 03

Note :- Dual input analysers are not acceptable for Conductivity, pH & DO Analysers.

2. Mandatory Spares as per Annexure E - Considered for evaluation
3. Commissioning Spares :  
Reagents required for commissioning & Handing over of System to Owner / end user .
4. O & M manuals in 04 copies. One copy shall be despatched to site along with material.  
One copy of O & M manual in Windows compatible software.
5. Calibration & Conformance certificates as per approved documents.
6. Following activities are in Vendor's scope:-
  - Total Commissioning & Handing over of Analysers to Customer / End User .
  - Coordination / Site support to Sample Handling System Vendor , as & when required.Specifications attached are for the complete SWAS including specification for Sample Handling system, which shall be procured separately. Analysers offered shall be suitable for working with the specifications indicated for sample handling system. In case, Vendor does not confirm as above, Offer shall be technically rejected. Vendor shall be required to visit site jointly with Sample Handling System Vendor for commissioning activity. BHEL shall inform with 15 days prior notice for the visit .



**PURCHASE SPECIFICATION  
FOR  
SWAS ANALYSERS**

CE/416/SWAS/ANALYSER/PS  
REV.NO.: 00  
Page 7 of 14

**SECTION- D**

|   |                                                                                                                                                                                                                                                                                                                                                                                                                                                                                                                                                                                                                                                                                                                                                                                                                                                                                                                                                                                                                                                                                                                                                                                                                                                                                                                                                                                                                                                                                                                                                                                                                                                                                                                                                                   |
|---|-------------------------------------------------------------------------------------------------------------------------------------------------------------------------------------------------------------------------------------------------------------------------------------------------------------------------------------------------------------------------------------------------------------------------------------------------------------------------------------------------------------------------------------------------------------------------------------------------------------------------------------------------------------------------------------------------------------------------------------------------------------------------------------------------------------------------------------------------------------------------------------------------------------------------------------------------------------------------------------------------------------------------------------------------------------------------------------------------------------------------------------------------------------------------------------------------------------------------------------------------------------------------------------------------------------------------------------------------------------------------------------------------------------------------------------------------------------------------------------------------------------------------------------------------------------------------------------------------------------------------------------------------------------------------------------------------------------------------------------------------------------------|
| A | General Requirement of Analysers:-                                                                                                                                                                                                                                                                                                                                                                                                                                                                                                                                                                                                                                                                                                                                                                                                                                                                                                                                                                                                                                                                                                                                                                                                                                                                                                                                                                                                                                                                                                                                                                                                                                                                                                                                |
|   | <ul style="list-style-type: none"><li>- All analysers, cells, monitors etc. as offered shall be field proven, Microprocessor based analyser with self-diagnostic feature. The Bidder shall furnish along with his proposals all the required details in respect of each and every type of analysers/cells/monitors to establish that the offered analytical instruments are well proven for the similar applications.</li><li>- The Bidder shall indicate in the offer the exact chemical composition of each and every reagent.</li><li>- The make, type, model etc. of various analytical instruments shall be subjected to the Owner's approval.</li><li>- The Bidder shall provide 2 x 4-20 mA linear isolated current output signals from analysers.</li><li>- All analysers / monitors shall be furnished with all required accessories for proper functioning.</li><li>- All sensors shall be supplied with 30 meter/run cable along with analysers.</li><li>- Alarm contacts shall be furnished with the analysers/monitors for annunciation of high or / and low alarms as indicated in list of analysers. The contact rating shall be 5A at 240 V AC./ 0.5 A at 220V DC.</li><li>- All analysers shall have Digital communication facility like RS 485 / HART/Modbus/Profibus.</li><li>- Item No. of BOM as approved or Item No. of BOM issued along with MC shall be put on the respective Boxes &amp; Packing list by the vendor for easy correlation &amp; identification at the time of MRC.</li><li>- Items shall be supplied, post inspection, in sturdy wooden packing. Packing shall be designed such that materials can be stored in open environment for 3 years. BHEL packing standard is enclosed for reference &amp; compliance.</li></ul> |



**PURCHASE SPECIFICATION  
FOR  
SWAS ANALYSERS**

CE/416/SWAS/ANALYSER/PS  
REV.NO.: 00  
Page 8 of 14

|          |                                                            |                                                                                                            |
|----------|------------------------------------------------------------|------------------------------------------------------------------------------------------------------------|
| B.       |                                                            |                                                                                                            |
| <b>1</b> | <b>Technical Specifications of Conductivity Analyser</b>   |                                                                                                            |
| a        | Applicable standard                                        | ASME PTC 19.11 except as modified in this specification.                                                   |
| b        | Type:                                                      |                                                                                                            |
|          | i) Cell                                                    | Flow through type/ removable type (withdrawable type with sealing valve)                                   |
|          | ii) Monitors                                               | Electronic (Microprocessor based) indicating type with multi range facility                                |
| c        | Accuracy                                                   | ± 1% of full scale span                                                                                    |
| d        | Stability                                                  | ±1% of full scale per month non-cumulative                                                                 |
| e        | Repeatability                                              | ±0.3% of span                                                                                              |
| f        | Additional features                                        | i) Automatic temperature compensation in the range 0- 100°C                                                |
|          |                                                            | ii) Ammonia (NH <sub>3</sub> ) removal equipment.                                                          |
|          |                                                            |                                                                                                            |
| <b>2</b> | <b>Technical Specification of pH Cell and Transmitters</b> |                                                                                                            |
| a        | Applicable Standard                                        | pH electrodes shall conform to IS:6804 except as modified in this specification                            |
| b        | Cell                                                       | Measuring and Reference Electrode Combination with Flow through type                                       |
| c        | Monitors                                                   | Electronic (microprocessor based) indicating type with adjustable range facility.                          |
| d        | Accuracy/repeatability                                     | ± 0.03 pH/+0.02PH                                                                                          |
| e        | Resolution                                                 | ± 0.01 pH or 1 mV. 1C                                                                                      |
| f        | Stability                                                  | 0.02 pH per week                                                                                           |
| g        | Accessories                                                | i) Automatic temperature compensation with fast response integral temperature sensors in the range 0-100°C |



**PURCHASE SPECIFICATION  
FOR  
SWAS ANALYSERS**

CE/416/SWAS/ANALYSER/PS  
REV.NO.: 00  
Page 9 of 14

|          |                                                             |                                                                                                                                                                                                   |
|----------|-------------------------------------------------------------|---------------------------------------------------------------------------------------------------------------------------------------------------------------------------------------------------|
|          |                                                             |                                                                                                                                                                                                   |
| <b>3</b> | <b>Technical Specification of Dissolved Oxygen Analyser</b> |                                                                                                                                                                                                   |
| a        | Applicable Standards                                        | ASTM PTC 19.11 except as modified in this specification                                                                                                                                           |
| b        | Type                                                        | Electro-chemical                                                                                                                                                                                  |
| c        | Accuracy                                                    | ±4% of full scale value                                                                                                                                                                           |
| d        | Sensitivity                                                 | ± two (2) per cent overall                                                                                                                                                                        |
| e        | Additional features                                         | Automatic temperature compensation in the range 0- 100°C                                                                                                                                          |
|          |                                                             |                                                                                                                                                                                                   |
| <b>4</b> | <b>Technical Specification of Silica Analyzer (SI OX)</b>   |                                                                                                                                                                                                   |
| a        | Applicable standard                                         | ASME PTC 19.11 except as modified in this specification                                                                                                                                           |
| b        | Type                                                        | Multi-Channel Calorimetric Analyzer with inbuilt sequencer (with auto reagent shut off feature in case of sample loss or power loss) built in phosphate inhibition feature. Microprocessor based. |
| c        | Accuracy                                                    | ±1% of span                                                                                                                                                                                       |
| d        | Repeatability                                               | ± 2% of full scale                                                                                                                                                                                |
| e        | Sensitivity                                                 | 0.2 ppb                                                                                                                                                                                           |
|          |                                                             |                                                                                                                                                                                                   |
| <b>5</b> | <b>Technical Specification of Hydrazine Analyzer</b>        |                                                                                                                                                                                                   |
| a        | Applicable standard                                         | ASME PTC 19.11 except as modified in this specification                                                                                                                                           |
| a        | Type                                                        | Electrochemical / Colorimetric                                                                                                                                                                    |
| B        | Accuracy                                                    | ± 2% of full scale                                                                                                                                                                                |
| c        | Sensitivity                                                 | 1.0 ppb                                                                                                                                                                                           |



**PURCHASE SPECIFICATION  
FOR  
SWAS ANALYSERS**

CE/416/SWAS/ANALYSER/PS  
REV.NO.: 00  
Page 10 of 14

| <b>6 Technical Specification of Sodium Ion Analyzer</b> |                     |                                                                                                                            |
|---------------------------------------------------------|---------------------|----------------------------------------------------------------------------------------------------------------------------|
| a                                                       | Applicable standard | ASME PTC 19.11 except as modified in this specification                                                                    |
| a                                                       | Type                | Continuous flow through sample type with sodium responsive electrode and reference electrode having pH adjustment facility |
| b                                                       | Accuracy            | ± 5% of full scale                                                                                                         |
| c                                                       | Sensitivity         | 0.1 ppb                                                                                                                    |
| <b>7 Technical Specification of Phosphate Analyzer</b>  |                     |                                                                                                                            |
| a                                                       | Applicable standard | ASME PTC 19.11 except as modified in this specification                                                                    |
| a                                                       | Type                | Continuous flow through sample type with calorimetric detection system                                                     |
| b                                                       | Accuracy            | ± 5% of full scale                                                                                                         |
| c                                                       | Sensitivity         | ± 5% of full scale                                                                                                         |
| <b>8 Technical Specification of Chloride analyser</b>   |                     |                                                                                                                            |
| a                                                       | Applicable standard | ASME PTC 19.11 except as modified in this specification                                                                    |
| b                                                       | Type                | Ion selective/ calorimetric detection system                                                                               |
| c                                                       | Accuracy            | ± 5 micro gram / litre                                                                                                     |
| d                                                       | Sensitivity         | ± 4% of full scale                                                                                                         |
| <b>9 Technical Specification of Ammonia analyser</b>    |                     |                                                                                                                            |
| a                                                       | Applicable standard | ASME PTC 19.11 except as modified in this specification                                                                    |
| b                                                       | Type                | Ion Selective / calorimetric detection system                                                                              |
| c                                                       | Accuracy            | ± 5 micro gram / litre                                                                                                     |
| d                                                       | Sensitivity         | ± 4% of full scale                                                                                                         |



**PURCHASE SPECIFICATION  
FOR  
SWAS ANALYSERS**

CE/416/SWAS/ANALYSER/PS  
REV.NO.: 00  
Page 11 of 14

|        |                                                                                                                                                                                                        |
|--------|--------------------------------------------------------------------------------------------------------------------------------------------------------------------------------------------------------|
| Note:- |                                                                                                                                                                                                        |
|        | 1. Vendors to clearly bring out deviations, if any, wrt specifications indicated above.                                                                                                                |
|        | 2. Vendors to note that Deviations shall be discussed with only those vendors who quote for this tender.                                                                                               |
|        | 3. Vendors to note that response time/cycle time of offered analysers shall be in line with industry standards/ as indicated for proven approved models by end users.                                  |
|        | 4. Typical range requirement of analysers is indicated in Table I below. Any change in ranges as per the requirement of specific project shall be incorporated without commercial implication to BHEL. |

**Table I**

| SI NO | Analyser                  | Typical Range                                                                                                                     |
|-------|---------------------------|-----------------------------------------------------------------------------------------------------------------------------------|
| 1     | Conductivity Analyser     | Specific:- 0- 10 / 0-100 / 0-1000 $\mu$ S/cm, freely programmable<br>Cation:- 0- 1 / 0-10 / 0-100 $\mu$ S/cm, freely programmable |
| 2     | pH Analyser               | 0-14 pH                                                                                                                           |
| 3     | Dissolved Oxygen Analyser | 0-20 / 0-200 ppb, freely programmable                                                                                             |
| 4     | Hydrazine Analyser        | 0-20 / 0-200 ppb, freely programmable                                                                                             |
| 5     | Silica Analyser           | 0-100 / 0-1000 ppb, freely programmable                                                                                           |
| 6     | Sodium analyser           | 0-20 / 0-1000 ppb, freely programmable                                                                                            |
| 7     | Phosphate Analyser        | 0-10 / 0- 50 ppm, freely programmable                                                                                             |
| 8     | Chloride Analyser         | 0-10 / 0-100 ppb, freely programmable                                                                                             |
| 9     | Ammonia Analyser          | 0-10 / 0-20 ppm, freely programmable                                                                                              |





**PURCHASE SPECIFICATION  
FOR  
SWAS ANALYSERS**

CE/416/SWAS/ANALYSER/PS  
REV.NO.: 00  
Page 12 of 14

**SECTION - "E"**

**MANDATORY SPARES FOR SWAS ANALYSERS**

| SL. NO. | DESCRIPTION                                                                           | Total Qty.                                           |
|---------|---------------------------------------------------------------------------------------|------------------------------------------------------|
| 1       | <b>:- Conductivity Analyser</b>                                                       |                                                      |
| a       | Conductivity cells of each type                                                       | 10 % of total qty for project or min. 2 nos.         |
| b       | Electronic module of each type                                                        | 10 % of total qty for project or min. 1 no each type |
| 2       | <b>:- pH Analyser</b>                                                                 |                                                      |
| a       | pH cells                                                                              | 10 % of total qty for project or min. 2 nos.         |
| b       | Electronic module of each type                                                        | 10 % of total qty for project or min. 1 no each type |
| 3       | <b>:- DO Analyser</b>                                                                 |                                                      |
| a       | Sensor assembly - complete assembly with ref. & measuring electrodes, electrolyte etc | 10 % of total qty for project or min. 1 no.          |
| b       | Electronic module of each type                                                        | 10 % of total qty for project or min. 1 no each type |
| 4       | <b>:- Hydrazine Analyser</b>                                                          |                                                      |
| a       | Sensor assembly - complete assembly with ref. & measuring electrodes, electrolyte etc | 10 % of total qty for project or min. 1 no.          |
| b       | Electronic module of each type                                                        | 10 % of total qty for project or min. 1 no each type |
| c       | Chemical reagents                                                                     | For One Year Supply                                  |
| 5       | <b>:- Silica Analyser</b>                                                             |                                                      |
| a       | Cuvette Assembly                                                                      | 1 no.                                                |
| b       | Pump motor                                                                            | 1 no.                                                |



**PURCHASE SPECIFICATION  
FOR  
SWAS ANALYSERS**

CE/416/SWAS/ANALYSER/PS  
REV.NO.: 00  
Page 13 of 14

|   |                                                                                       |                                                      |
|---|---------------------------------------------------------------------------------------|------------------------------------------------------|
| c | Tube replacement kit                                                                  | 1 set                                                |
| d | Reaction chamber assembly                                                             | 1 set                                                |
| e | Electronic module of each type                                                        | 10 % of total qty for project or min. 1 no each type |
| f | Chemical reagents                                                                     | For One Year Supply                                  |
| 6 | <b>:- Sodium Analyser</b>                                                             |                                                      |
| a | Sensor assembly - complete assembly with ref. & measuring electrodes, electrolyte etc | 1 no.                                                |
| b | Refurbishment kit                                                                     | 1 set                                                |
| c | Electronic module of each type                                                        | 10 % of total qty for project or min. 1 no each type |
| d | Chemical reagents                                                                     | For One Year Supply                                  |
| 7 | <b>:-Phosphate Analyser</b>                                                           |                                                      |
| a | Cuvette Assembly                                                                      | 1 no.                                                |
| b | Pump motor                                                                            | 1 no.                                                |
| c | Tube replacement kit                                                                  | 1 set                                                |
| d | Reaction chamber assembly                                                             | 1 set                                                |
| e | Electronic module of each type                                                        | 10 % of total qty for project or min. 1 no each type |
| f | Chemical reagents                                                                     | For One Year Supply                                  |
| 8 | <b>:- Chloride Analyser</b>                                                           |                                                      |
| a | Sensor assembly - complete assembly with ref. & measuring electrodes, electrolyte etc | 1 no.                                                |
| b | Refurbishment kit                                                                     | 1 set                                                |



**PURCHASE SPECIFICATION  
FOR  
SWAS ANALYSERS**

CE/416/SWAS/ANALYSER/PS  
REV.NO.: 00  
Page 14 of 14

|        |                                                                                                                     |                                                      |
|--------|---------------------------------------------------------------------------------------------------------------------|------------------------------------------------------|
| c      | Electronic module of each type                                                                                      | 10 % of total qty for project or min. 1 no each type |
| d      | Chemical reagents                                                                                                   | For One Year Supply                                  |
| 9      | <b>:- Ammonia Analyser</b>                                                                                          |                                                      |
| a      | Sensor assembly - complete assembly with ref. & measuring electrodes, electrolyte etc                               | 1 no.                                                |
| b      | Refurbishment kit                                                                                                   | 1 set                                                |
| c      | Electronic module of each type                                                                                      | 10 % of total qty for project or min. 1 no each type |
| d      | Chemical reagents                                                                                                   | For One Year Supply                                  |
|        |                                                                                                                     |                                                      |
| Note:- |                                                                                                                     |                                                      |
|        | 1. Vendors to quote individual prices for all items above. The prices shall be on per unit basis for each row item. |                                                      |
|        | 2. Vendors who do not comply pt. no. 1 will be disqualified from the tender.                                        |                                                      |

**SECTION F**

|                                                                                                  |                              |                                                          |
|--------------------------------------------------------------------------------------------------|------------------------------|----------------------------------------------------------|
|  <p>A4 - 15</p> | <p><b>PLANT STANDARD</b></p> | <p>ED 049 00 99</p> <p>REV NO 10</p> <p>PAGE 0 OF 28</p> |
|--------------------------------------------------------------------------------------------------|------------------------------|----------------------------------------------------------|

**REVISION HISTORY SHEET**

| REV NO. | DATE       | NATURE OF CHANGE                                                         | REASONS                                                               | CHANGED BY    | APPROVED BY |
|---------|------------|--------------------------------------------------------------------------|-----------------------------------------------------------------------|---------------|-------------|
| 00      | 06/03/92   | SUPERCEDES<br>CN43000                                                    | -                                                                     | VS MAS<br>SHG | N.J         |
| 01      | 19/06/93   | GENERAL                                                                  | FEEDBACK FROM<br>QUALITY                                              | SHG           | N.J         |
| 02      | 24/06/93   | CL 3.4.10                                                                | FEEDBACK FROM<br>QUALITY                                              | SHG           | N.J         |
| 03      | 01/07/93   | SEMICONDUCTOR<br>& PHTOVOLTAIC<br>PANELS ADDED                           | FEEDBACK FROM<br>DESPATCH                                             | SHG           | N.J         |
| 04      | 17/10/94   | TOTALLY REVISED                                                          | FEEDBACK FROM<br>QUALITY                                              | SHG           | N.J         |
| 05      | 08/06/95   | ANNEXURE ADDED                                                           | FEEDBACK FROM<br>QUALITY &<br>ACCEPTANCE<br>CRITERIA OF<br>WOOD ADDED | SHG           | N.J         |
| 06      | 17/11/95   | CL 2.5.10 ALTERED                                                        | FEEDBACK FROM<br>QUALITY &<br>SHIPPING                                | SHG           | N.J         |
| 07      | 05/03/97   | UNDER CL 3.0 &<br>3.9.1 RPP ADDED<br>ACCEPTANCE<br>CRITERIA<br>REMOVED   | FEEDBACK FROM<br>SHIPPING & QC                                        | SHG           | N.S         |
| 08      | 29/08/2001 | CL 2.2.8 & 4.1<br>CHANGED                                                | FEEDBACK FROM<br>SHIPPING & QC                                        | SHG           | NS          |
| 09      | 15.12.2009 | INCLUSION OF PINE<br>WOOD AND SOME<br>CLAUSES HAVE<br>AMENDED            | FEEDBACK FROM<br>SHIPPING                                             | PGD / KPN     | MSS         |
| 10      | 21.06.2013 | Inclusion of<br>recommendations<br>pertaining to spares in<br>page-11&28 | Recommendations<br>from Corporate<br>systems & IT                     | HRN           | MSS         |

COPY RIGHT AND CONFIDENTIAL  
The information on this document is the property of BHARAT HEAVY ELECTRICALS LIMITED.  
It must not be used directly or indirectly in any way detrimental to the interest of the company.

REV-10.

APPROVED: M. Sivaramaiah

PREPARED: HRN

ISSUED: STDS GROUP

DATE: 21/06/13



## PLANT STANDARD

ED 049 00 99

REV NO 10

PAGE 1 OF 28

### PROCEDURE FOR PACKING OF CONTROL EQUIPMENTS PRODUCTS USING RUBBER WOOD, SILVER OAK WOOD, PINE WOOD AND CARTONS

**1.0 SCOPE:** This standard covers the guidelines for packing of Control Equipments, semiconductor devices and Photo voltaic panels/cells.

#### 2.0 MATERIALS:

##### 2.1 WOOD:

**2.1.1 INLAND:** The wood shall be Rubber wood (*Havea Brasiliensis*) for packing of cubicles, loose items, spares and photovoltaic items meant for customers in India.

**2.1.2 EXPORT:** Silver Oak (*Grevillea Robusta*) / Pine wood shall be used for packing of cubicles and loose items meant for export.

##### 2.2 DIMENSIONS:

**2.2.1** Thickness of planks for Front, rear, top and bottom sides and binding, jointing battens shall be 25 +2/-3 mm.

**2.2.2** Width of all planks including the tongue shall be more than 125 mm after planing, except to adjust total height of item to be packed.

**2.2.3** Minimum number of planks shall be used for a shook.

**2.2.4** In any case, only one plank can be of width less than 125 mm, but greater than 100 mm.

**2.2.5** Horizontal, vertical, diagonal planks shall be given for binding (number of such planks depend on the dimension of panel, as given in Figure-2).

**2.2.6** External sides of front and rear planks to be planed to facilitate writing of address and other markings.

**2.2.7** Width of binding planks shall be minimum 100 mm.

REV-10

APPROVED: M. Sivaramaiah

PREPARED: HRN

ISSUED: STDS GROUP

DATE: 21/06/13



A4 - 14

## PLANT STANDARD

ED 049 00 99

REV NO 10

PAGE 2 OF 28

- 2.2.8 Distance between any 2 binding planks shall be less than 750 mm. As shown in Fig-3, diagonal planks shall be used in between vertical binding planks when distance between inner to inner of vertical planks is more than 750 mm
- 2.2.9 Distance of the outer edges of these planks from the edge of case shall be less than 250 mm.
- 2.2.10 Diagonal planks are not required for top planks and width side also, if the width of pallet is less than 750 mm.
- 2.2.11 **Jointing of planks:** Single length planks shall be used for cubicles whose overall length is less than 2400 mm. For cubicles of length more than 2400 mm, jointing is permitted. The jointing shall be done with one single or maximum of 2 planks of wood same as other planks of width 250 mm (minimum) with two rows of nails on either side of the joint in zigzag manner. From the joint along height side it shall be of lap joint with over lap of at least the width of plank.
- 2.2.12 **Tongue and Groove joints:** Two Consecutive planks shall be joined by tongue and groove joint. Depth of tongue shall be  $12 \pm 1$  mm, thickness of tongue shall be  $8 \pm 1$  mm. The groove dimensions shall be such that the tongue fits tightly into the groove to make a good joint.
- 2.3 **PERMISSIBLE DEFECTS:** - Wood shall be free from knots, bows, visible sign of infection and any kind of decay caused by insects, fungus, etc.

*End splits:* Longest end splits at each end shall be measured and lengths added together. The added length shall not exceed 60 mm per meter run of shook's. Wood pins shall be used to prevent further development of split.

*Surface cracks:* Surface cracks with a maximum depth of 3 mm are permissible. A continuous crack of any depth all along the length is not allowed.

### 2.4 .0 CHEMICAL TREATMENTS FOR PRESERVATION OF WOOD:-

- 2.4.1 This treatment provides protection to the packing wood against deterioration due to fungi and attack by termites, borers and marine organism and any kind of infections.
- 2.4.2 The wooden planks, after making tongues / grooves shall be treated with chemicals. For pine wood, treatment with ASCU/ CCA solution need not be done.
- 2.4.3 The chemical used shall be ready mix ASCU paste. This consists of Arsenic pent oxide, copper sulphate sodium dichromate. This Paste shall be mixed at the rate of 1 kg of paste per 10 liters of water to the extent of water used. Alternate this CCA paste as mentioned at Para 2.4.5 can also be used.
- 2.4.4 The chemical treatment shall be done at the premises of the contractor. A cement concrete tank of capacity to hold a minimum of 2000 liters of solution shall be constructed. The solution



A4 - 14

## PLANT STANDARD

ED 049 00 99

REV NO 10

PAGE 3 OF 28

shall be prepared in the presence of BHEL- EDN's Representative by contractor. The wooden planks shall be soaked in the solution for a minimum of 12 hours. The solution shall be replenished after treating a maximum of 12 cubic meters of wood. A log book shall be maintained by the contractor to give the details of date of preparation of solution, quantity of solution prepared, quantity of chemicals used, Quantity of wood treated and the details of replenishment. Samples of solutions before mixing will be got tested at the laboratories designated by BHEL. The testing fees to be paid to the laboratories will have to be borne by the contractor. The paste shall be tested as and when required.

### 2.4.5 Specifications for water soluble type wood preservatives: Copper – Chromium – Arsenic [CCA]:

Copper – Chromium – Arsenic preservative formulation shall be as per IS : 10013 Part – II – 1981 shall consist of following active ingredients in nominal proportions by weight as shown below:

|                      |                           |      |
|----------------------|---------------------------|------|
| Arsenic Pent oxide   | $AS_2O_5 \cdot 2H_2O$     | 12.5 |
| Copper Sulphate      | $CuSO_4 \cdot 5H_2O$      | 37.5 |
| Sodium Dichromate    | $Na_2Cr_2O_7 \cdot 5H_2O$ | 50.0 |
| Or                   |                           |      |
| Potassium Dichromate | $K_2Cr_2O_7$              |      |

### 2.5 OTHER MATERIALS:

2.5.1 NAILS: The dia. of the nails shall be 3.15 mm. The length of the nails shall be 65 mm wherever two planks of 25 mm thickness are joined and 75 mm wherever a 25 mm planks is joined to a 50 mm plank.

2.5.2 BLUE NAILS: These are used for nailing bituminized Kraft paper/hessian cloth to the planks. The length of the nails shall be 16 mm.

2.5.3 HOOP IRON STRIPS: These are used for strapping the boxes. The width of the strips shall be  $19 \pm 1$  mm and thickness  $0.6 \pm 0.01$  mm. The material shall be free from rust.

2.5.4 CLIPS: These shall be used for strapping the hoop iron strips on the boxes.

2.5.5 BRACKETS: These brackets are used for nailing to the corners of cubicle boxes. The brackets shall be of mild steel of thickness  $2 \pm 1$  mm and width  $25 \pm 1$  mm. The brackets shall be of "L" shape, the length of each side being  $100 \pm 2$  mm. Two holes shall be provided towards the end of each side for screwing /nailing.



A4 - 14

## PLANT STANDARD

ED 049 00 99

REV NO 10

PAGE 4 OF 28

2.5.6 FASTENERS: Bolts, double nuts, spring washers will have to be used for packing of some special items like transformers, reactors, breakers, etc., to hold the job to the bottom plank of the box. The bolts, nuts, washers will be provided by BHEL. However, drilling of holes will have to be done using contractor's tools.

2.5.7 POLYETHYLENE SHEET: The polyethylene sheets are used to make covers to the jobs individually. The material shall have a thickness of 0.175 mm (175 microns). The polyethylene sheet shall be clear and transparent.

2.5.8 BITUMINISED WATER PROOF KRAFT PAPER: This is used for lining the inside of shoots of cubicles.

2.5.9 BITUMEN COATED HESSIAN POLYETHYLENE KRAFT PAPER: This is used for lining the inside of top planks of cubicles and for lining of all inner sides of boxes.

2.5.10 RUBBERISED COIR: The rubberized coir is used as cushioning material. For the packing of loose items, items are to be arrested by using rubberized coir. For the packing of cubicles rubberized coir of thickness 25mm and width 75mm shall be used.

2.5.11 FOAM RUBBER / 'U' FOAM: This is used for covering the delicate items. This material is normally provided by BHEL.

2.5.12 THERMOCOL (EXPANDED POLYSTYRENE) SHEETS: This is used for covering delicate items. This material is normally provided by BHEL.

2.5.13 MARKING PLATE: This shall be of anodized aluminum sheet. Details and specifications are given in Fig-5.

2.5.14 PACKING SLIP HOLDER: This shall be of galvanized iron /tinned

2.5.15 SILICA GEL: This shall be of indicating type.

2.5.16 COTTON BAGS: These are used for holding silica gel. The bags shall have the following matter indicated them:

-----  
BHEL-EDN, BANGALORE - 5 60 026

SILICA GEL INDICATING TYPE

BLUE : ACTIVE

ROSE : REDUCED ACTIVITY

WHITE : NO ACTIVITY. TO BE REPLACED WITH FRESH SILICA GEL  
-----





## PLANT STANDARD

ED 049 00 99

REV NO 10

PAGE 5 OF 28

2.5.17 COTTON/ PLASTIC TAPE: This is used for tying small items .And also to prevent vibrations of moving parts within the cubicles.

2.5.18 MARKING INK: The ink used normally is black in color. In some special cases other color also will have to be used. The ink shall be non-fading/indelible and non-washable by water.

2.5.19 POLYETHYLENE BAGS: These are to be used for keeping the, Packing slips. The bag shall be of size 70 mm X 100 mm (minimum).

2.5.20 Hessian cloth, twine thread, paint will have to be used in packing certain items.

2.5.21 Mechanical Latching clamps: For CLW Railway panels and similar Panels self locking clamps can also be used on need basis in conjunction with or apart from regular bolt and nut fixing arrangement. [Refer Drawing Fig-7]. For reusable boxes, these clamps provide easy locking and unlocking arrangement. These clamps will be made available from BHEL in some cases.

**3. 0 PACKING SPECIFICATIONS:** Different types of packing are used as follows:

- 1) Packing of cubicles with rubber wood.
- 2) Packing of cubicles with Silver Oak wood / Pine wood
- 3) Packing of empty cubicles with rubber wood.
- 4) Packing of loose items/spares with rubber wood.
- 5) Packing of loose items /spares with Silver Oak wood.
- 6) Packing of Photo-voltaic items with rubber wood.
- 7) Packing using bitumen coated hessian polyethylene Kraft papers.
- 8) Supply of rubber wood pallets for empty cubicles.
- 9) Packing of semiconductor panels.
- 10) Packing of material covered under category of RPP (Registered Postal Parcel)
- 11] Packing of materials using PVC [sunspace] / corrugated Kraft paper cartons.
- 12] Packing of materials using heavy duty cartons

**3.1 PACKING OF CUBICLES WITH RUBBER WOOD:**

3.1.1 The packing is to be done as per clause 2.O in all respects.

3.1.2 The cubicles are already fixed on wooden pallets. Hence the contractor need not arrange the bottom pallets normally.

3.1.3 The cubicles will be of different sizes both widthwise and lengthwise. The cubicles may be made up of single suite, 2 Suite, 3 Suite, 4 Suite, etc., The width of the cubicles generally varies from 400 mm to 1650mm.The length of the cubicle, generally varies from 1500 mm to 4800 mm. The height is normally 2430 mm. In some cases the height may be less/more.



## PLANT STANDARD

ED 049 00 99

REV NO 10

PAGE 6 OF 28

- 3.1.4 BITUMINISED WATER PROOF KRAFT PAPER: The inner surface of 4 sides of shoo's shall be nailed with Bituminized water proof Kraft paper (as per 2.5.8) using blue nails (as per 2.5.2) wherever 2 pieces of Kraft paper are used, the joint shall have an overlap of minimum 20 mm.
- 3.1.5 BITUMEN COATED HESSIAN POLYETHYLENE KRAFT PAPER: The inner surface of top cover shall be nailed with Bitumen coated Hessian polyethylene Kraft paper (as in 2.5.9). This sheet shall project outside on 4 sides by at least 100 mm and shall be nailed properly on sides. Joining of sheets should have overlap of minimum 20 mm.
- 3.1.6 POLYETHYLENE SHEET COVERING: The cubicles shall be covered with a polyethylene petticoat (Polyethylene sheet as per 2.5.7). This shall be 'tailor made' to fit the cubicle. The sealing shall be such as not to allow any moisture to enter the cubicle.
- 3.1.7 SILICA GEL: Silica gel (as per 2.5.15) packed in cotton bags shall be kept at different places inside the cubicle as per EDN directions. Each suit of cubicle shall be provided with 1 kg of Silica gel (for a 4 suit cubicle 4 kgs of Silica Gel to be used. The bag containing silica gel to be as per 2.5.16).
- 3.1.8 LOOSE PARTS: Any loose parts in the cubicles shall be tied using cotton/ plastic tape. Wooden battens shall be provided wherever necessary.
- 3.1.9 WOODEN BATTENS: In case of cubicle which are not rectangular in shape like control desks, sufficient number of wooden rafters/battens of proper size shall be provided to give strength to the package.
- 3.1.10 RUBBERISED COIR: Gap between the cubicle and the case shall be filled with rubberized coir (as per 2.5.10) with distance between consecutive layers less than 500 mm.
- 3.1.11 CLAMPING: Packing shall be bound at edges by nailing M.S.clamps / Brackets (as per 2.5.5). Each vertical edge shall have minimum 3 clamps. Top horizontal edges will have one clamp for every meter length of package. However, minimum 4 clamps shall be nailed at the top for any cubicle.
- 3.1.12 PACKING SLIP: Packing slip kept in the polyethylene bag (As per 2.5.19) shall be placed in the box at appropriate place. In addition, one more packing slip covered in polyethylene cover and packing slip holder (as per 2.5.14) shall be nailed to front / rear of case.
- 3.1.13 MARKING PLATE: One no. (As per 2.5.13) shall be nailed to the front side of the case.
- 3.1.14 CASE MOUNTING: After complete packing, stencil marking of various details and marking of symbols shall be done as per BHEL instructions using indelible / non washable marking ink.



## PLANT STANDARD

ED 049 00 99

REV NO 10

PAGE 7 OF 28

3.2 PACKING OF CUBICLES WITH SILVER OAK / PINE WOOD: Packing of cubicles for export shall be done exactly in same manner as described at 3.1 except for the following changes: -

- Wood shall be Silver oak/ Pine wood instead of rubber wood.
- Double polyethylene petticoat instead of one.
- Fumigation may have to be done if required ( BHEL Scope).

3.3 Different types of Cubicles with sizes for Packing

-----  
SL TYPE OF CUBICLE VARIANT DIMENSIONS [Internal sizes]  
-----

|                         |                      |
|-------------------------|----------------------|
| 01 Single suite cubicle | - 900 x 950 x2500    |
| 02 Two suite cubicle    | - 1650 x 950 x 2500  |
| 03. Three suite cubicle | - 2400 x 950 x2500   |
| 04. Four suite cubicle  | - 3150 x 950 x 2500  |
| 05. Regulation cub      | - 1300 x 1350 x 2500 |
| 06. Thy cub             | - 2870 x 1350 x 2500 |
| 07. VFD Cub             | - 3800 x 1550 x 2500 |

3.4 PACKING OF LOOSE ITEMS/SPARES USING RUBBER WOOD:

3.4.1 Shape of cases shall be square, rectangular with single gabled roof or with double gabled roof depending on the nature of the job to be packed. Construction shall be as per drawings enclosed. Only gable will be additional as required.

3.4.2 Wood shall be rubber wood with Tongue and Groove joint as per clause 2.2.12.

3.4.3 Chemical treatment as per clause 2.4 to be done.

3.4.4 Width of planks shall be at least 100 mm. Width of binding planks (battens) shall be at least 75mm.

3.4.5 External surface of planks on front and rear shall planed 100% (except bottom plank).

3.4.6 Inner surfaces of all 6 sides shall be lined with bitumen coated hessian polyethylene Kraft paper (as per clause 2.5.9) using blue nails.

3.4.7 Rubberized coir of minimum 25mm thickness and 100 mm width shall be nailed to inner surfaces of bottom and 4 sides of box.

3.4.8 Internal packing: Items that go into the box shall be packed using polyethylene sheet/ U foam/ thermocol sheets/ air bubbled sheets/ paper cartoons and cotton tape. Any space left. Between the job and the sides and the top of the box shall be filled with rubberized coir to get proper cushioning effect.



## PLANT STANDARD

ED 049 00 99

REV NO 10

PAGE 8 OF 28

3.4.9 Certain items like transformers, reactors, breakers, etc., shall be bolted to the bottom of the box using bolts, nuts and washers.

3.4.10 Silica gel as per clause 2.5.15 held in cotton bags as per clause 2.5.16 shall be kept at proper places in the box.

| SL NO | BOX INNER DIMENSIONS (mm) | VOLUME (liters) | QUANTITY OF SILICA GEL (grams) |
|-------|---------------------------|-----------------|--------------------------------|
| 1     | 300X300X300               | 27              | 100                            |
| 2     | 400X400X400               | 64              | 100                            |
| 3     | 500X500X400               | 100             | 100                            |
| 4     | 600X600X400               | 144             | 100                            |
| 5     | 700X700X400               | 196             | 100                            |
| 6     | 770X770X500               | 297             | 100                            |

3.4.11. Packing slip kept in polyethylene bag (clause 2.5.19) shall be placed in the box.

3.4.12. Marking plate as per clause 2.5.13 shall be nailed to side of the box.

3.4.13. Two numbers of hoop iron strips as per clause 2.5.3 shall be strapped tightly on the case using clips.

3.4.14. Stencil marking of various details and marking of various symbols shall be done as per BHEL instructions using indelible/non-washable marking ink.

3.4.15 Loose items to be kept inside the cubicle

- The components which are removed from cubicle for shipping purpose only, such as meters shall be kept inside the cubicle individually kept in wooden box and tied firmly in bottom of Cubicle.
- Other items which are given loose in addition to cubicle shall be packed in separate boxes (like cables).
- For transformer cubicles loose items shall be packed in separate boxes and these boxes may be tied firmly in bottom of cubicles.
- Items which are bigger in size such as impulse tubes may be kept in top of cubicles firmly bunched and tied.



## PLANT STANDARD

ED 049 00 99

REV NO 10

PAGE 9 OF 28

3.5. PACKING OF LOOSE ITEMS USING SILVER OAK / PINE WOOD: Packing of loose items for export shall be done in same manner as at clause.3.4 . except for the following changes:

- Wood shall be Silver oak/ Pine wood instead of rubber wood.
- Fumigation may have to be done.
- 2 polyethylene covers to be provided.

3.6 PACKING OF PHOTO VOLTAIC PANELS, ETC.USING RUBBER WOOD:  
Same as 3.4 above except for the following changes:

- Wood need not be treated with chemical solution.
- Tongue and groove jointing is not required. But planks shall be so joined as to not leave any gap at the joint. Bituminized Kraft paper and Bituminized Kraft sheet need not be used.
- Silica gel need not be used.

3.7 PACKING USING BITUMEN COATED HESSIAN POLYETHYLENE KRAFT PAPER:

3.7.1. This method is adopted for packing of poles, frames, Empty boxes, etc.

3.7.2. Job shall be covered and stitched tightly with bitumen coated hessian polyethylene Kraft paper.

3.7.3. Marking has to be done as mentioned in CL 3.4.14.

3.8 SUPPLY OF RUBBER WOOD PALLETS FOR EMPTY CUBICLES:

3.8.1. The wood shall be rubber wood.

3.8.2. Thickness of planks shall be  $25 \pm 2$  mm. The size of the supporting battens at bottom shall be  $75 \pm 2$  mm (width) and  $100 \pm 2$  mm (height).

3.8.3. If the width of the pallet is 1000 mm or less, only 2 supporting battens at the edges may be provided. In case of pallets having width of more than 1000 mm, one extra supporting batten shall be provided in the middle.

3.8.4. Jointing of top planks is not permitted for pallets of width less than 1000mm. For pallets of width more than 1000 mm, jointing of top plank is permitted. However, joint shall be at the center of the supporting batten.

|                                                                                   |                       |                                            |
|-----------------------------------------------------------------------------------|-----------------------|--------------------------------------------|
|  | <b>PLANT STANDARD</b> | ED 049 00 99<br>REV NO 10<br>PAGE 10 OF 28 |
|-----------------------------------------------------------------------------------|-----------------------|--------------------------------------------|

3.8.5 The consecutive top planks shall be so nailed as to leave no gap. Tongue and groove joint is not required.

### 3.9 PACKING OF SEMICONDUCTOR DEVICES

Semiconductor devices shall be received in prepackaged condition as per the device type and packed in plywood boxes as per the following procedure,

- Provide thermocole sheets/rubberized coir.
- Stack the preplaced devices inside the case.
- Fill up gaps with thermocol sheets/rubberized coir.
- Close the top cover and nail.
- Provide suitable marking of the package details.

3.9.1 Packing of material for Registered Post Parcel (RPP) RPP packing boxes to be made in-house with 12mm (for sides) and 6mm thick (for top and bottom) commercial quality ply wood sheet. The size of the box should be decided on the material to be dispatched. Between material 10mm and 15mm thick thermocole sheets or rubberized coir/foam should be provided as cushion.

3.9.2. Packing of materials using sunpac cartons and corrugated Kraft paper cartons: Individual items can be packed using sunpac or polypropylene [PVC]/ corrugated Kraft paper cartons of suitable sizes and grammage depending upon the items to be packed. Heavy duty cartons can also be used for packing of loose items, manuals, repaired items and others.

3.9.3. Packing of materials using Heavy duty cartons: Panels can also be packed using Heavy duty carton with other required packing materials having 2000gsm corrugated board of 7 ply 15 thick. Loose items and spares can be packed using 5ply 2000gsm corrugated heavy board with other packing materials. Different sizes of cartons are required depending upon the sizes of the items being packed. Details are separately given.

### 4.0 ADDITIONAL POINTS TO BE FOLLOWED FOR EXPORT ORDER SEAWORTHY PACKING:

4.1 Packing to be done as per Fig - 6.  
Thickness of G.I.sheet 0.3 mm. plus or minus 0.05 [0.3-0.05]

**Additional points to be taken care for :**

|                                                                                   |                         |                                            |
|-----------------------------------------------------------------------------------|-------------------------|--------------------------------------------|
|  | <h2>PLANT STANDARD</h2> | ED 049 00 99<br>REV NO 10<br>PAGE 11 OF 28 |
|-----------------------------------------------------------------------------------|-------------------------|--------------------------------------------|

**Easy spares [Initial and O&M ] Traceability and Identification at units and as well as at sites:**

(Recommendations from Corporate Systems & IT)

| Sl | Activity                                                                                                                                                                                                                                                                                                                                                                                                                |
|----|-------------------------------------------------------------------------------------------------------------------------------------------------------------------------------------------------------------------------------------------------------------------------------------------------------------------------------------------------------------------------------------------------------------------------|
| 1  | All Initial and O&M spares preferably supplied in one lot to site and progressive inventory till all spares are accumulated could be kept at units.                                                                                                                                                                                                                                                                     |
| 2  | Spares (Initial and O&M) should be supplied in separate Boxes / Containers and not mixed in main supply boxes.                                                                                                                                                                                                                                                                                                          |
| 3  | <b>i)</b> Initial spares Box / Container to be labeled as "INITIAL SPARES " in RED. Ref fig: 14 (Page-26).<br><b>ii)</b> O & M spares Box /Container to be labeled as" O&M SPARES " in GREEN. Ref fig: 14 (Page-26).                                                                                                                                                                                                    |
| 4  | <b>iii)</b> Initial Spares Box to have red Color strip as per diagram. Ref fig: 14 (Page-26).<br><b>iv)</b> Majority of spares (initial and O&M) are for indoor storage at site.<br><b>v)</b> O&M spares box to have green Color strip as per diagram. Ref fig: 14 (Page-26).                                                                                                                                           |
| 5  | <b>vi)</b> Spares (Initial and O&M ) Packing list kept inside the boxes and affixed securely outside the box to contain<br><b>vii)</b> Custom name<br><b>viii)</b> Project / Power station Name<br><b>ix)</b> Customer PO No and date<br><b>x)</b> Sl no of customer PO.<br><b>xi)</b> Quantity total & dispatched.<br><b>xii)</b> Unit work order number<br><b>xiii)</b> All above to be developed from Unit IT System |
| 6  | <b>xiv)</b> All spares (Initial and O&M) items to have tags (wono, item customer order no, customer item.description)                                                                                                                                                                                                                                                                                                   |
| 7  | <b>xv)</b> Supply of spares by Vendor should also be instructed for following point 2,3,4,5,6 mentioned above.                                                                                                                                                                                                                                                                                                          |

**Action By : Sites on arrival of spares (Initial and O&M)Receipt .**

|   | Activity                                                                                                                                                                                                                    |
|---|-----------------------------------------------------------------------------------------------------------------------------------------------------------------------------------------------------------------------------|
| 1 | Material utilized if any from Initial and O&M spares , should have prior written approval of concerned MUs. Such MUs shall also confirm replacement dates which should be entered in the system for creation of repository. |



## PLANT STANDARD

ED 049 00 99

REV NO 10

PAGE 12 OF 28

### 5.0 DETAILS OF DRAWINGS/FIGURES ENCLOSED

FIG-1: Details Of Cubicle Packing Box

FIG-2: Binding Of Panel

FIG-3: Lifting Of Packed Case

NOTE: 1) Spreaders are to be used only for lifting the case.

2) Spreaders are wooden items & not nailed to the case.

3) Height between crane hook & spreaders to be kept Minimum to void rotation of case while lifting.

FIG-4: Lifting And Moving Un Packed Case

FIG-5: Marking Plate

FIG-6: Closed Packing Case With G.I. Sheet Showing Layers Of Packing Materials.

FIG-7: Mechanical Latching Clamp

FIG-8 to 15 : Sample Packing drawing of single/ double / triple & four suit pane.l





A4 - 14

# PLANT STANDARD

ED 049 00 99

REV NO 10

PAGE 13 OF 28

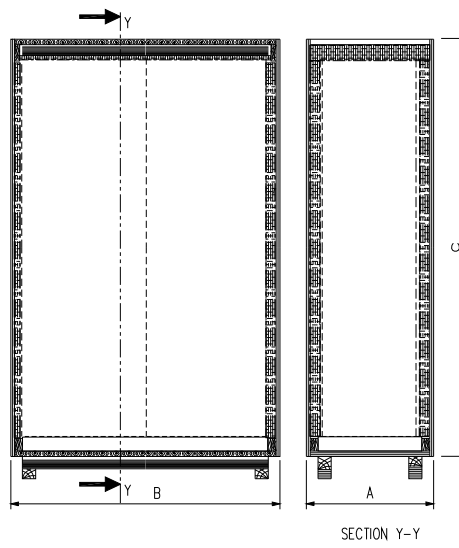

FIG-1 : DETAILS OF CUBICLE PACKING BOX.



# PLANT STANDARD

ED 049 00 99

REV NO 10

PAGE 14 OF 28

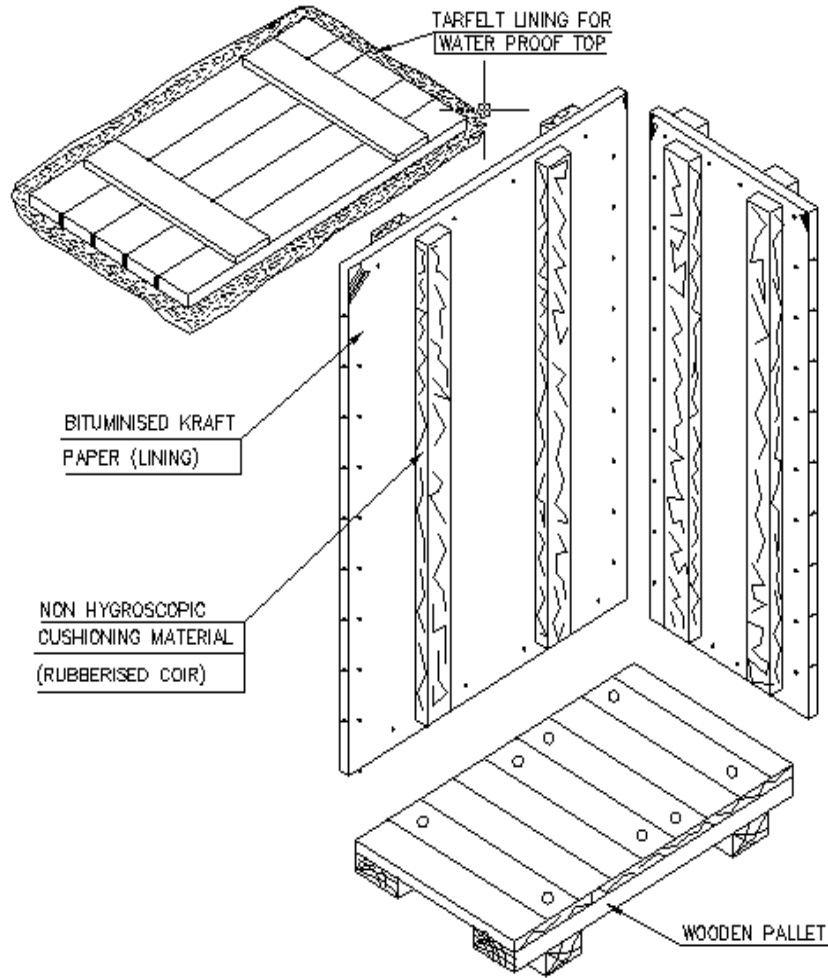

Fig. 2 : Binding of Panel

COPY RIGHT AND CONFIDENTIAL  
The information on this document is the property of BHARAT HEAVY ELECTRICALS LIMITED.  
It must not be used directly or indirectly in any way detrimental to the interest of the company.



A4 - 14

# PLANT STANDARD

ED 049 00 99

REV NO 10

PAGE 15 OF 28

COPY RIGHT AND CONFIDENTIAL  
The information on this document is the property of BHARAT HEAVY ELECTRICALS LIMITED.  
It must not be used directly or indirectly in any way detrimental to the interest of the company.

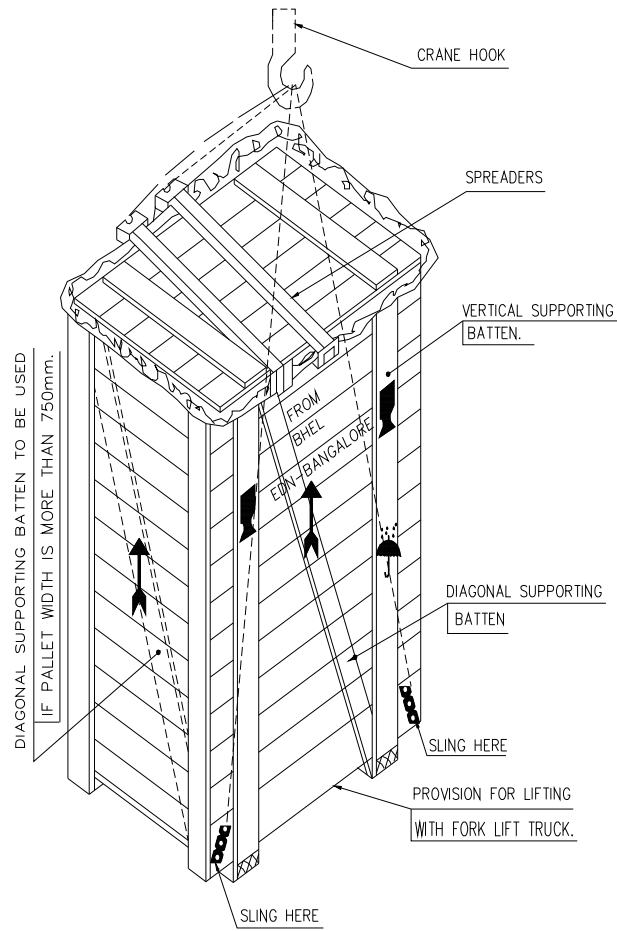

FIG-3 : LIFTING OF PACKED CASE.



A4 - 14

# PLANT STANDARD

ED 049 00 99

REV NO 10

PAGE 16 OF 28

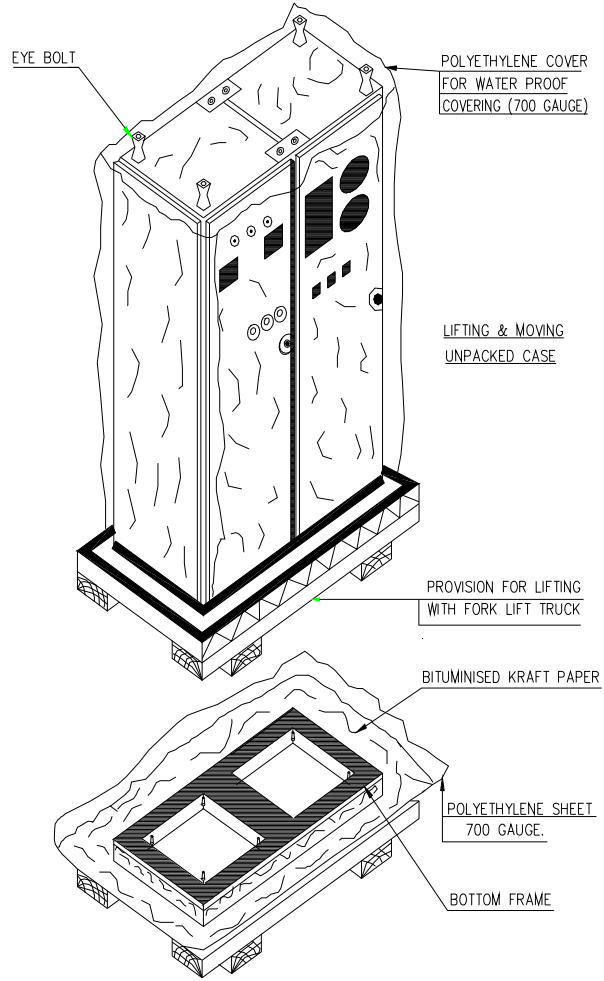

FIGURE-4

COPY RIGHT AND CONFIDENTIAL  
The information on this document is the property of BHARAT HEAVY ELECTRICALS LIMITED.  
It must not be used directly or indirectly in any way detrimental to the interest of the company.

COPY RIGHT AND CONFIDENTIAL  
 The information on this document is the property of BHARAT HEAVY ELECTRICALS LIMITED.  
 It must not be used directly or indirectly in any way detrimental to the interest of the company.

|                                                                                                  |                         |                                                           |
|--------------------------------------------------------------------------------------------------|-------------------------|-----------------------------------------------------------|
|  <p>A4 - 14</p> | <h1>PLANT STANDARD</h1> | <p>ED 049 00 99</p> <p>REV NO 10</p> <p>PAGE 17 OF 28</p> |
|--------------------------------------------------------------------------------------------------|-------------------------|-----------------------------------------------------------|

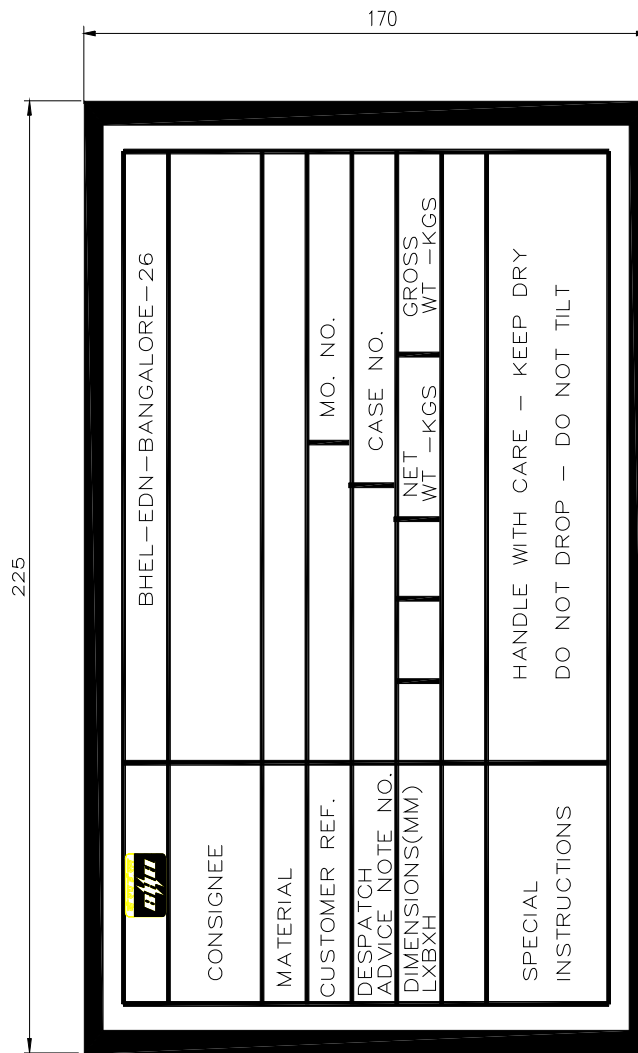

FIG-5 : MARKING PLATE.



A4 - 14

# PLANT STANDARD

ED 049 00 99

REV NO 10

PAGE 18 OF 28

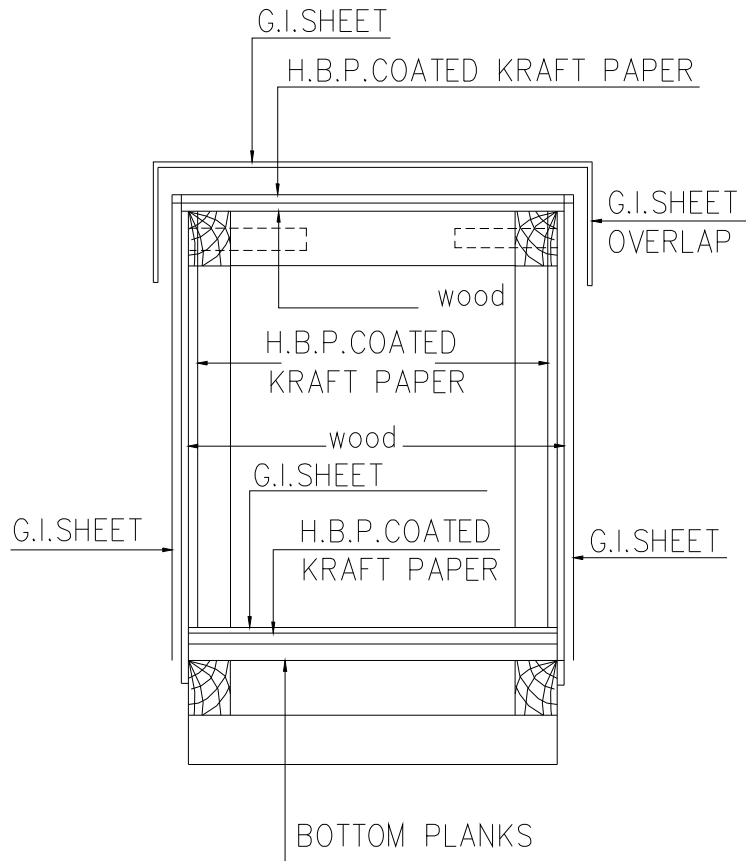

FIG-6 : CLOSED PACKING CASE WITH G.I.SHEET  
SHOWING LAYERS OF PACKING MATERIALS.

COPY RIGHT AND CONFIDENTIAL  
The information on this document is the property of BHARAT HEAVY ELECTRICALS LIMITED.  
It must not be used directly or indirectly in any way detrimental to the interest of the company.





**PLANT STANDARD**

ED 049 00 99

REV NO 10

PAGE 20 OF 28

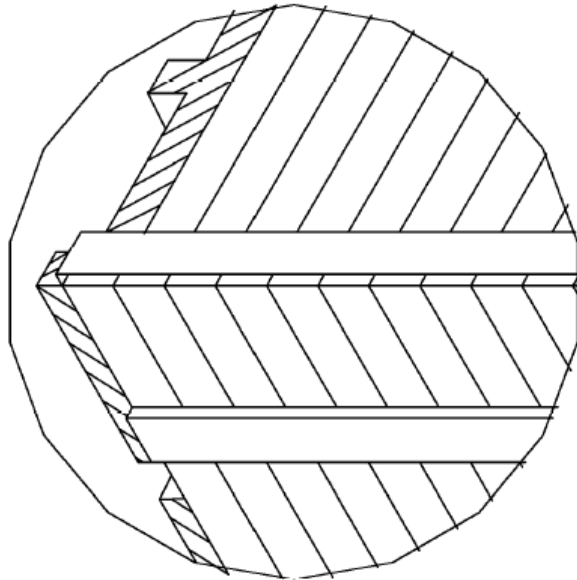
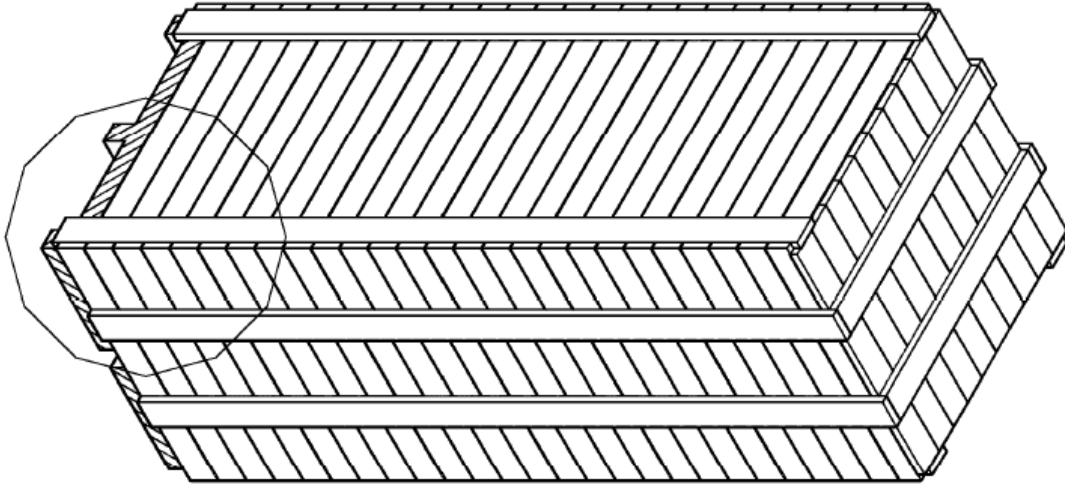

**Fig – 8 : Single Suit Cubicle Packing View**

COPY RIGHT AND CONFIDENTIAL  
The information on this document is the property of BHARAT HEAVY ELECTRICALS LIMITED.  
It must not be used directly or indirectly in any way detrimental to the interest of the company.





**PLANT STANDARD**

ED 049 00 99

REV NO 10

PAGE 21 OF 28

COPY RIGHT AND CONFIDENTIAL  
 The information on this document is the property of BHARAT HEAVY ELECTRICALS LIMITED.  
 It must not be used directly or indirectly in any way detrimental to the interest of the company.

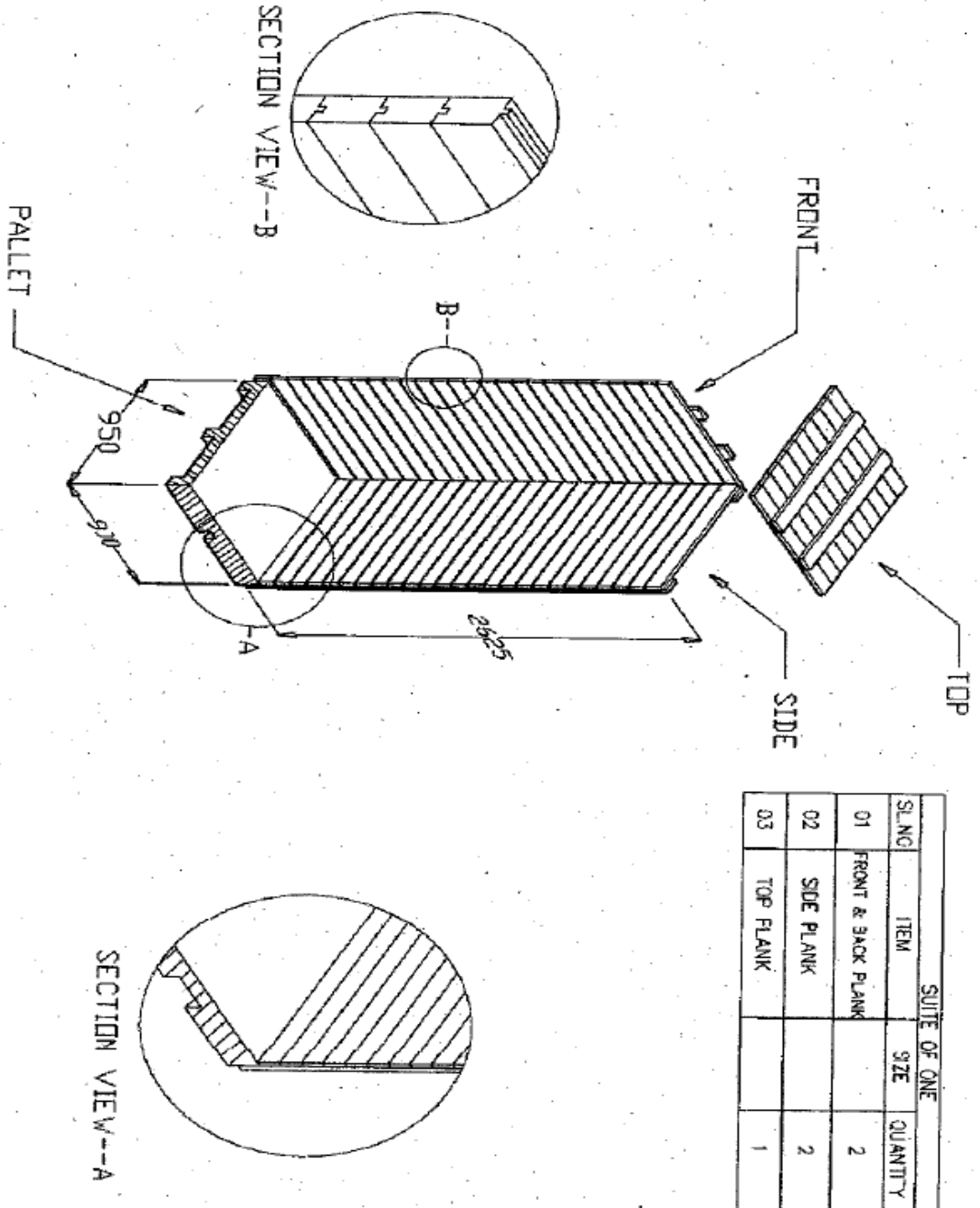

**Fig - 9 : Single Suit Packing Assembly Drawing**



**PLANT STANDARD**

ED 049 00 99

REV NO 10

PAGE 22 OF 28

COPY RIGHT AND CONFIDENTIAL  
 The information on this document is the property of BHARAT HEAVY ELECTRICALS LIMITED.  
 It must not be used directly or indirectly in any way detrimental to the interest of the company.

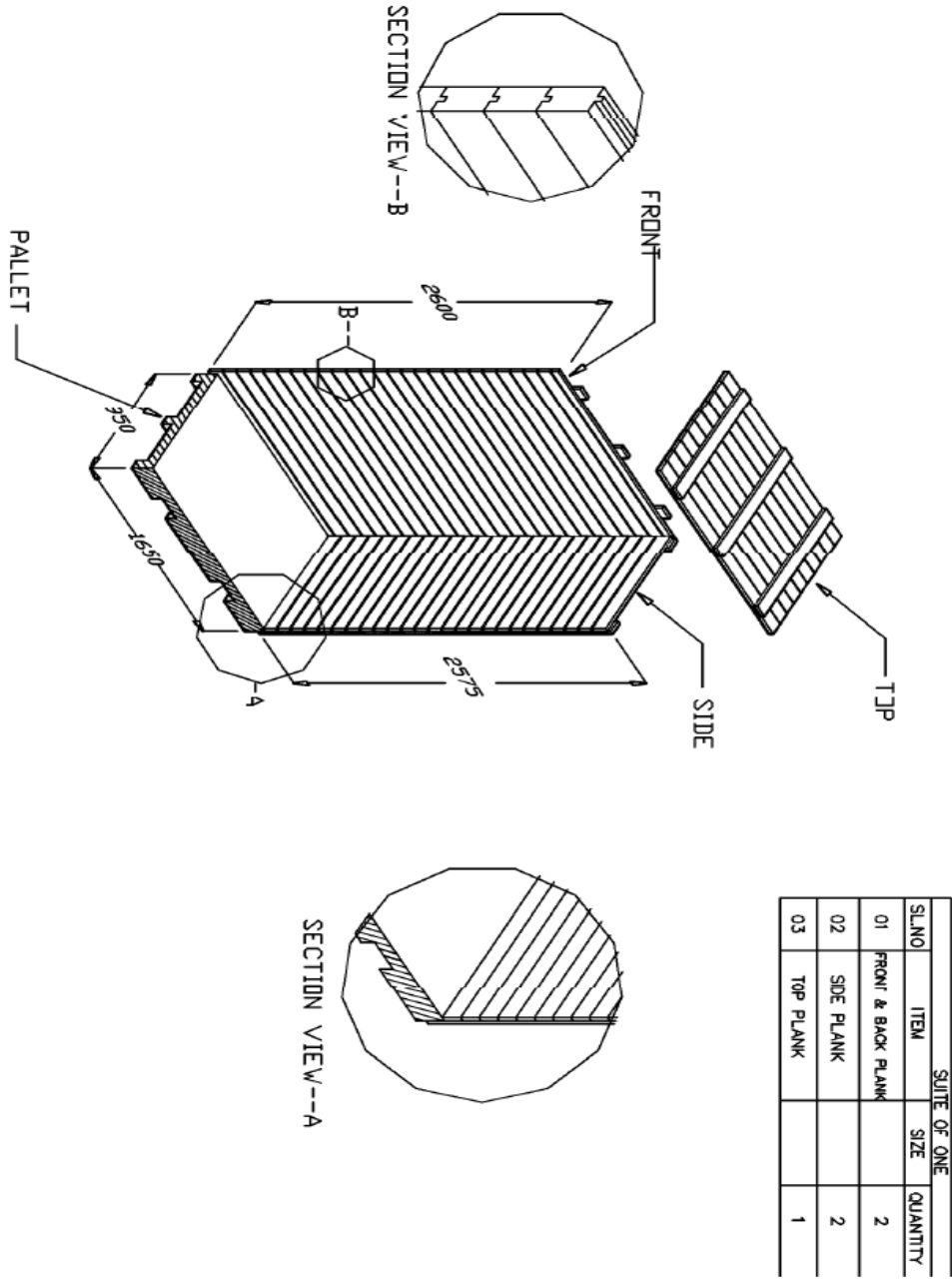

**Fig – 10 : Two Suit Packing Assembly Details**



**PLANT STANDARD**

ED 049 00 99

REV NO 10

PAGE 23 OF 28

COPY RIGHT AND CONFIDENTIAL  
The information on this document is the property of BHARAT HEAVY ELECTRICALS LIMITED.  
It must not be used directly or indirectly in any way detrimental to the interest of the company.

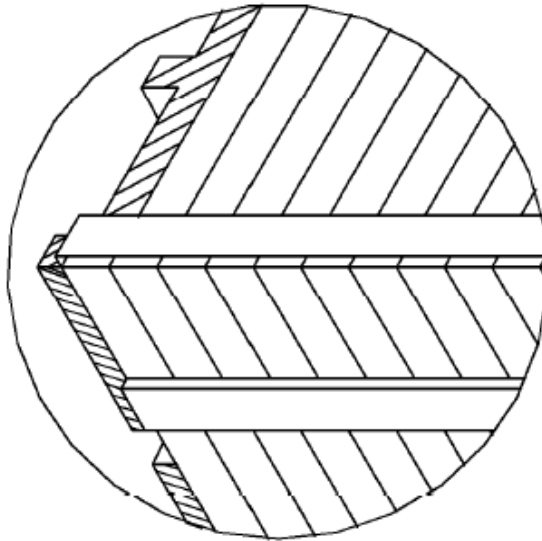
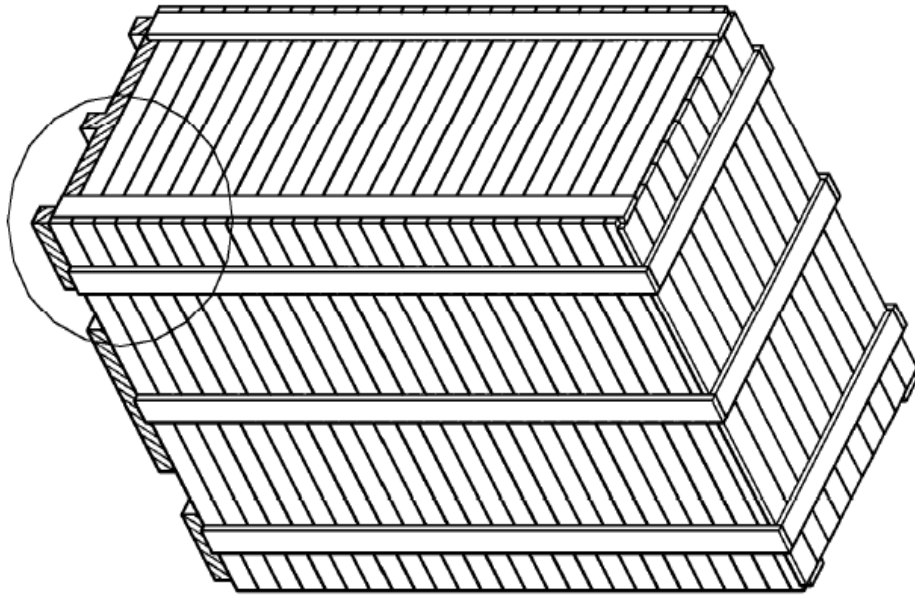

**Fig – 11 : Two Suit Panel Packed view**



**PLANT STANDARD**

ED 049 00 99

REV NO 10

PAGE 24 OF 28

COPY RIGHT AND CONFIDENTIAL  
 The information on this document is the property of BHARAT HEAVY ELECTRICALS LIMITED.  
 It must not be used directly or indirectly in any way detrimental to the interest of the company.

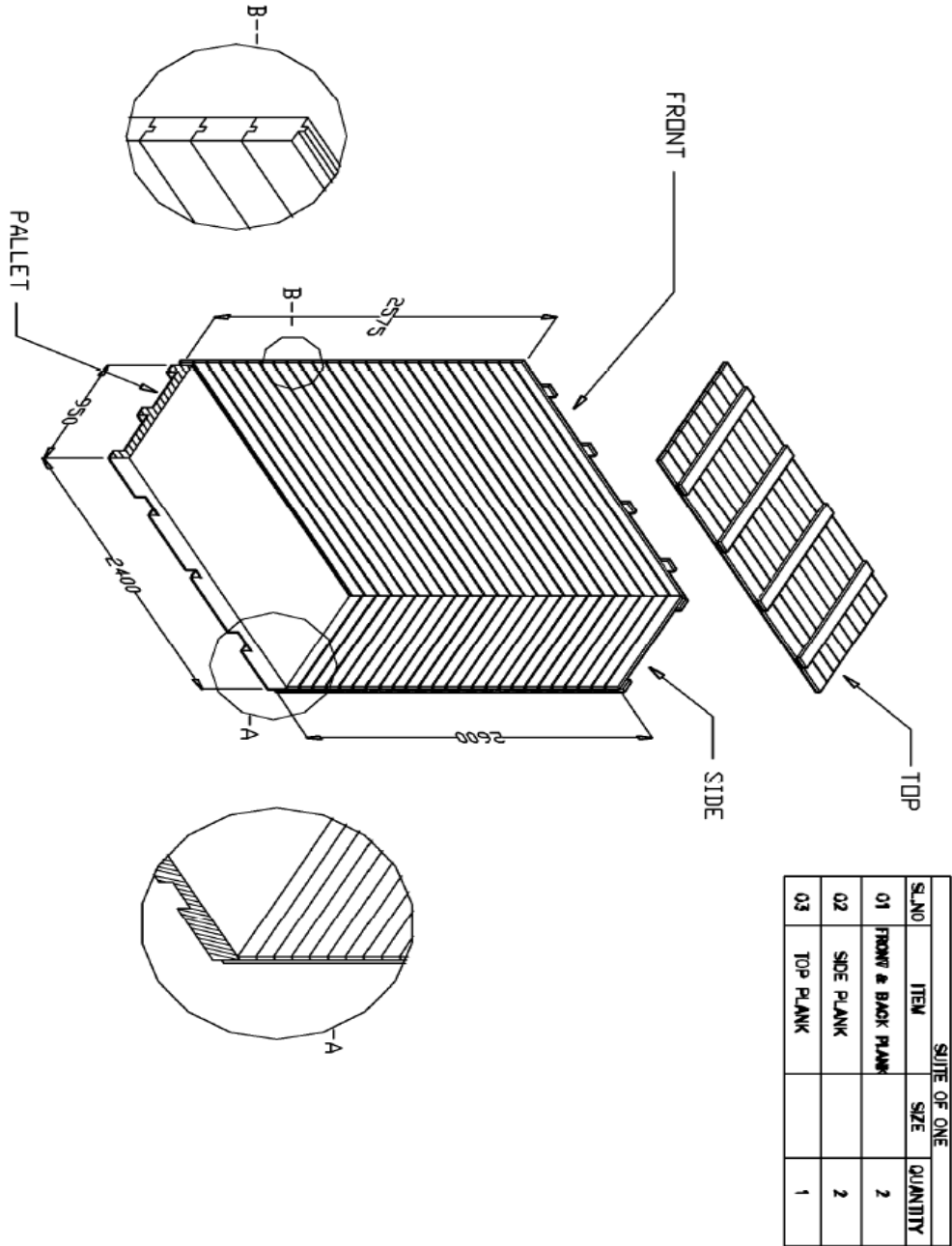

**Fig – 12 : Three Suit Panel Packing Assembly View**



**PLANT STANDARD**

ED 049 00 99

REV NO 10

PAGE 25 OF 28

COPY RIGHT AND CONFIDENTIAL  
The information on this document is the property of BHARAT HEAVY ELECTRICALS LIMITED.  
It must not be used directly or indirectly in any way detrimental to the interest of the company.

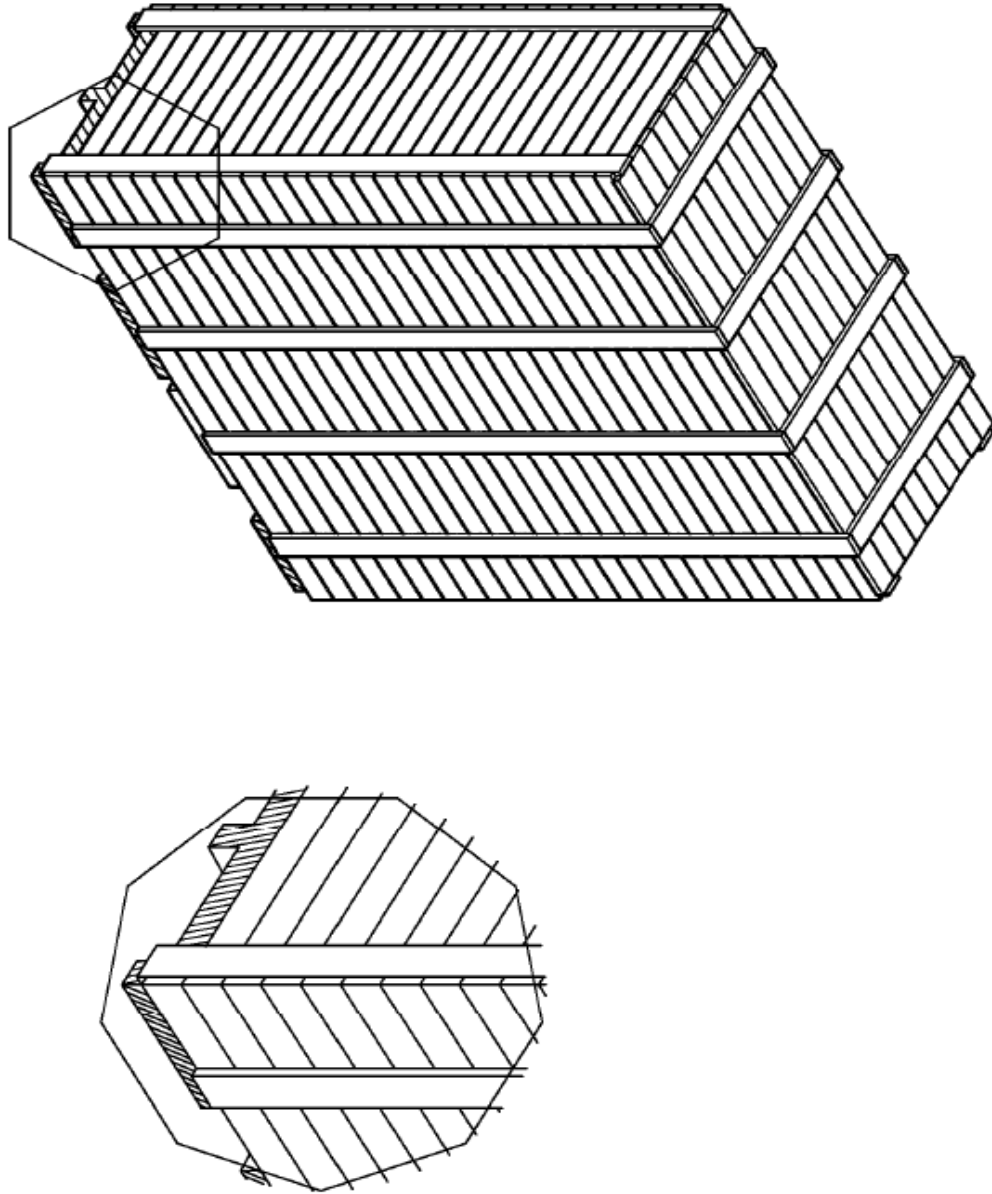

**Fig -13 : Three Suit Panel Packed View**



**PLANT STANDARD**

ED 049 00 99

REV NO 10

PAGE 26 OF 28

COPY RIGHT AND CONFIDENTIAL  
 The information on this document is the property of BHARAT HEAVY ELECTRICALS LIMITED.  
 It must not be used directly or indirectly in any way detrimental to the interest of the company.

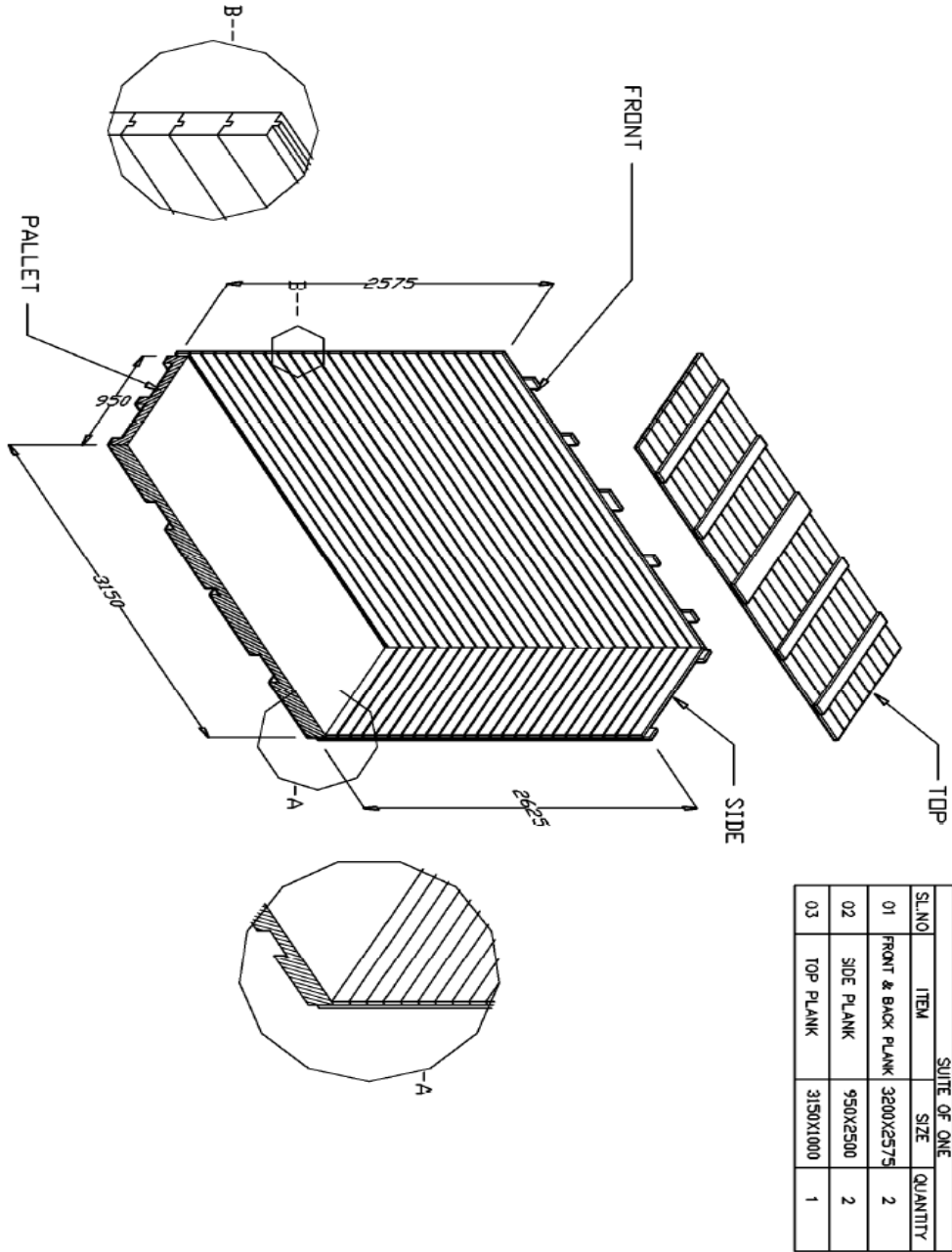

**Fig – 14 : Four Suit Panel Packing assembly Detail**



**PLANT STANDARD**

ED 049 00 99

REV NO 10

PAGE 27 OF 28

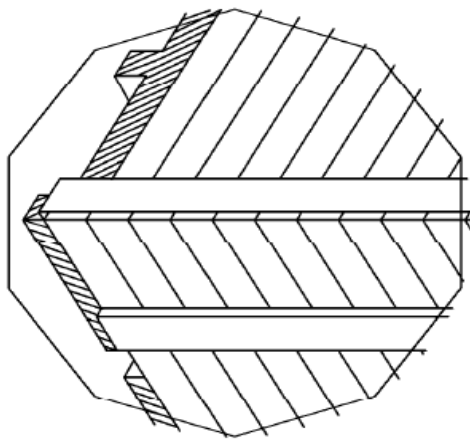
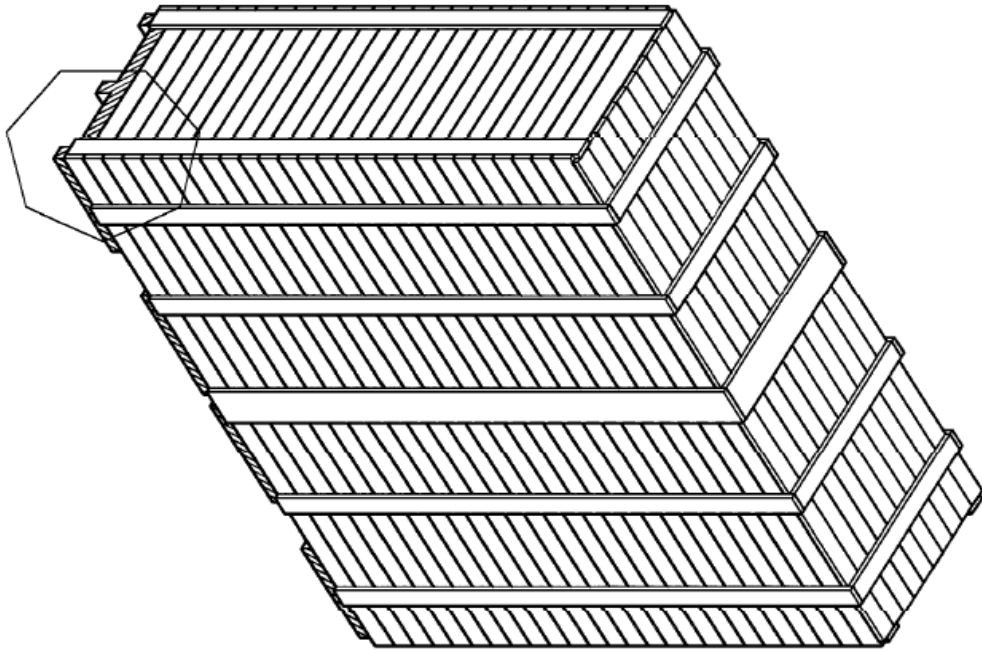

---

**Fig -15 : Four Suit Panel Packing View**

|                                                                                   |                       |                                            |
|-----------------------------------------------------------------------------------|-----------------------|--------------------------------------------|
|  | <b>PLANT STANDARD</b> | ED 049 00 99<br>REV NO 10<br>PAGE 28 OF 28 |
|-----------------------------------------------------------------------------------|-----------------------|--------------------------------------------|

Easy spares [Initial and O&M ] Traceability and Identification at units and as well as at sites:

Fig: 14

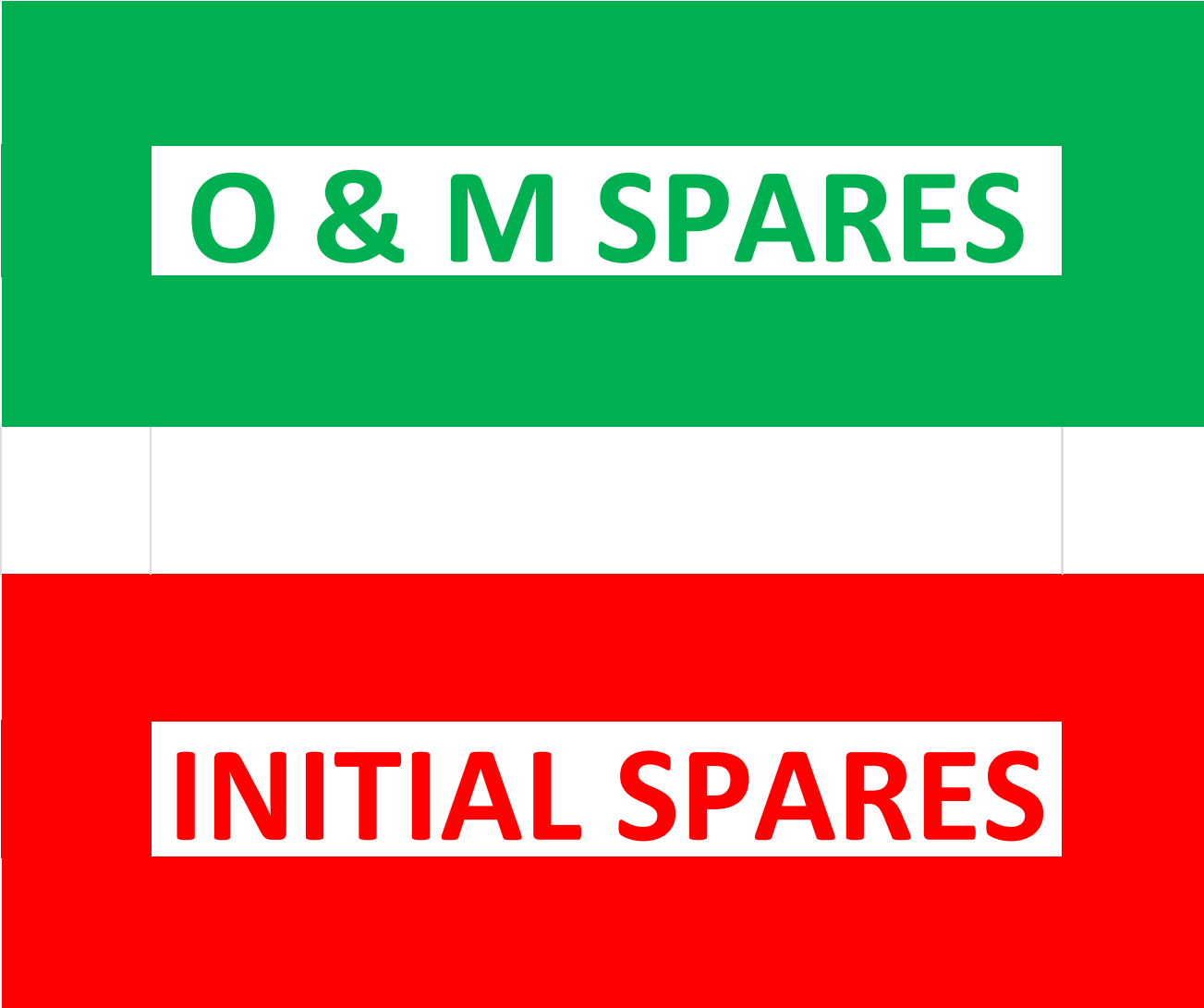



## SPECIAL CONDITIONS OF CONTRACT (SCC)

**REF:- RFQ No.: PKN0000031 DATED 23.12.2013 DUE ON 24.01.2014**

### **1. PROJECT & ITEM DETAILS:**

| <b>Sl. No.</b> | <b>PROJECT</b>                  | <b>ITEM</b>                                   | <b>TENTATIVE REQUIREMENT</b> |
|----------------|---------------------------------|-----------------------------------------------|------------------------------|
| 1              | SAGARDIGHI (2 X 500 MW)         | ANALYZERS FOR STEAM AND WATER ANALYSIS SYSTEM | MAY'14                       |
| 2              | DVC BOKARO (1 X 500 MW)         | ANALYZERS FOR STEAM AND WATER ANALYSIS SYSTEM | SEP'14                       |
| 3              | BELLARY (1 X 700 MW)            | ANALYZERS FOR STEAM AND WATER ANALYSIS SYSTEM | SEP'14                       |
| 4              | YERMARUS (2 X 800 MW)           | ANALYZERS FOR STEAM AND WATER ANALYSIS SYSTEM | DEC'14                       |
| 5              | FARAKKA R & M (2 X 500MW)       | ANALYZERS FOR STEAM AND WATER ANALYSIS SYSTEM | JULY'14                      |
| 6              | SINTEX INFRA(2X150)             | ANALYZERS FOR STEAM AND WATER ANALYSIS SYSTEM | JULY'14                      |
| 7              | SINGARENI (2 X 600 MW)          | ANALYZERS FOR STEAM AND WATER ANALYSIS SYSTEM | DEC'14                       |
| 8              | LALITPUR (3 X 660 MW)           | ANALYZERS FOR STEAM AND WATER ANALYSIS SYSTEM | DEC'14                       |
| 9              | OPG KUTCH - 2 X 150 MW          | ANALYZERS FOR STEAM AND WATER ANALYSIS SYSTEM | JUNE'14                      |
| 10             | APGENCO RAYALSEEMA - 1 X 600 MW | ANALYZERS FOR STEAM AND WATER ANALYSIS SYSTEM | DEC'14                       |
| 11             | 30 TH BHEL HYD                  | ANALYZERS FOR STEAM AND WATER ANALYSIS SYSTEM | JUNE'14                      |

Note 1: Bidders can indicate their schedule against each project, if the above tentative requirement is not suitable to them.

Note 2: Bidders should have financial soundness, Organizational capability, Service network, etc. to meet the requirement of above 11 projects together.

### **2. LOCATION & BENEFITS APPLICABLE FOR A PROJECT: As per enclosure**

3. **PRE BID MEETING:** Pre bid meeting is fixed on 26.12.2013 from 1.00 PM onwards at BHEL EDN, Bangalore. Bidders can attend the meeting to obtain all the clarifications required for bidding. However, clarifications can be sought through emails also, which will be replied through website as corrigendum. Hence bidders have to regularly visit web site.

**VENUE FOR PRE-BID MEETING: CE-MM: PURCHASE RESOLD GROUP, NEW ENGG BUILDING – II FLOOR, BHEL EDN, MYSORE ROAD, BANGALORE – 26, KARNAKATA.**

4. **BULKY QUOTATIONS :** In cases where Quotations are bulky and not fitting in the tender box provided at Reception Area , BHEL, EDN, Bangalore or due to some reasons tenders are required to be submitted by hand, such tenders can be handed over before due date & time to following persons and obtain acknowledgement with date & time:

a. **P K NAGARAJ, SR. ENGINEER/ CE-MM-PR, PH: 080 26998179, MOB: 9483501488.**

b. **PONNUGURU PACKIAM, SR. DGM/ CE-MM-PR, PH: 080 26998669.**

5. **PACKAGE PURCHASE:** Entire Tendered projects/items will be processed as a package on a single vendor i.e. L1 (Lowest bidder), who is technically and commercially meeting BHEL requirements and whose offer is economical to BHEL.

~~All the above projects are having Customer approved vendors. If the successful bidder (L1 bidder), is not approved by ultimate Customer for any of their projects, such bidder will be referred to customer with credentials for their approval. All out efforts will be made with Customer to get the approval. In case the customer does not approve a bidder for a project, then the successful bidder's (L1) offer will not be considered for placement of PO for that particular project only.~~

Bidder's credentials in hard copy as well as in CD should be submitted alongwith offer.

BHEL reserves the right to issue Purchase orders for all projects to the L1 bidder. However, for any reason BHEL is not able to issue order for few projects, the successful bidder has to honor the purchase orders for balance projects.

6. **UNIT RATES:** Price bid should contain price break-up i.e. unit rates for each part number / item must be provided at the time of bid submission compulsorily. Unit rates shall be part of Original price bid.

All items with part numbers and unit rates shall be kept as base and BOM is worked out for each project as per the template given below:

Model for submission of Price Bid:

| Sl. No | Item Description | Part Number / Model Number | Unit rate (Foreign currency / INR) | PROJECT AA |                         |             |
|--------|------------------|----------------------------|------------------------------------|------------|-------------------------|-------------|
|        |                  |                            |                                    | Qty/ Unit  | Qty for -- No. of units | Total Value |
| 1      | xxx              | Model: abc                 | \$ 1.00                            | 1          | 1                       | \$ 1.00     |
| 2      | xxx              | Model: xyz                 | Rs. 3.00                           | 5          | 5                       | Rs. 15.00   |

**Same shall continue for all the projects requirement.**

7. **PRICE BID:** Any discount/ revised offer submitted by a bidder on its own will be accepted provided it is received on or before the due date and time of offer submission (i.e. Part-I bid). The discount will be applied on pro-rata basis to all items unless specified otherwise by the bidder.

Unsolicited discounts/ revised offers given after Part-1 bid opening will not be considered.

In case there is no change in the technical scope or specifications or commercial terms & conditions by BHEL, the bidder/s will not be allowed to change the original price bids.

In case of changes in scope and/ or technical specifications and/ or commercial terms & conditions by BHEL, having price implications, techno-commercially acceptable bidders will be asked (after freezing the scope, technical specifications and commercial terms & conditions) to submit the impact only for such changes on their original price bid.

In case of any bidder, after finalizing the scope of supply, opting to revise total price bid and re-submit their latest price bid instead of submitting impact, then their original price (i.e. the previous bid) will also be opened to know the price

impact wherever changes are taken place. Any unsolicited discount given on unchanged portion will not be considered.

8. **ERRORS IN OFFER:** All quotations shall be free from corrections /overwriting. Corrections if any should be initialed with signature and seal. Any typographical error, totaling mistakes, currency mistake, multiplication mistake, summing mistakes etc. observed in the price bids will be evaluated as per Clause 11.2.3 “Non-conformities between the figures and words of the quoted prices” of “Manual on Policies & Procedures for purchase of goods” issued by Ministry of Finance / Government of India.(Refer Annexure II). BHEL decision will be final.
9. **SLAB RATES:** BHEL reserves the right to consider and place order for any of the future requirements based on the unit prices available within from the date of placement of PO. This will be applicable to additional site requirements / spares also.
10. **DELIVERY SCHEDULE:** as follows:
  - For Sagardighi (2 Units): 8 weeks from the date of issue of manufacturing clearance or documents approval, whichever is earlier.
  - For balance projects: As per tentative schedule mentioned in SI No.1 .

Tentative project schedules have been given at SI No.1 above. However, BHEL will indicate the delivery requirement for each project while placing Purchase Order / issuing manufacturing clearance. BHEL may ask for early delivery for some of the critical projects which are in advance stage for which vendors have to accommodate.

11. **ERECTION & COMMISSIONING:** Lumpsum as required basis (including to & fro fare, boarding, lodging & local conveyance) should be quoted. Limitation to number of visits / days will not be accepted.
12. **REVERSE AUCTION:** BHEL reserves the right to go for Reverse Auction (RA) instead of opening the sealed envelope price bid, submitted by the bidder. This will be decided after techno-commercial evaluation. All bidders to give their acceptance for participation in RA. Non-acceptance to participate in RA may result in non-consideration of their bids, in case BHEL decides to go for RA.

In case BHEL decides to go for Reverse Auction, only those bidders who have given their acceptance to participate in RA will be allowed to participate in the Reverse Auction. Those bidders who have given their acceptance to participate in Reverse Auction will have to necessarily submit “online sealed bid” in the Reverse Auction. Non-submission of “online sealed bid” by the bidder will be considered as tampering of the tender process and will invite action by BHEL as per extant guidelines in vogue.
13. **HIGH SEA SALES (HSS):** Customs clearance of the consignment landed on Indian Sea / Air ports will be done by BHEL based on the original HSS documents provided by vendors.

Any delay in submission of complete / correct HSS documents to BHEL may incur demurrage charges. All demurrage charges on account of incomplete / incorrect HSS documents submission by vendor will be to vendor’s account and all such charges will be recovered from any of the available vendor bills with BHEL.

14.

15. **GUIDELINES REGARDING DEALING WITH INDIAN AGENTS OF FOREIGN SUPPLIERS (guidelines copy attached):**

- i. The consultant / firm (and any of its affiliates) will not be eligible to participate in tender/s for the related goods or works or services for the same project, if they were engaged for the consultancy services.
- ii. Procurement directly from the manufacturers/ suppliers shall be preferred. However, if the OEM/ Principal insists on engaging the services of an agent, such agent shall not be allowed to represent more than one manufacturer/ supplier in the same tender. Moreover, either the agent could bid on behalf of the manufacturer/ supplier or the manufacturer/ supplier could bid directly but not both. In case bids are received from the manufacturer/ supplier and the agent, bid received from the agent shall be ignored. The extant guidelines issued by Corp. MM for regulation of Agents of foreign principals shall be followed.

Following to be furnished along with commercial terms & conditions:

- a. Agency agreement copy as it is a mandatory requirement.
- b. It shall be incumbent on the Indian Agent and the foreign principal to adhere to the relevant Guidelines of Govt Of India, issued from time to time.
- c. The responsibility for successful execution of the contract (including Indigenous supplies/services) lies with the OEM/foreign principal.
- d. All bank Guarantees to this effect shall be in the scope of OEM/foreign principal.

16. **IMITATION OF LIABILITY:** Vendor's liability towards this contract is limited to a maximum of 100% of the contract value and consequential damages are excluded. However the limits of liability will have no effect in cases of criminal negligence or willful misconduct.

The total liability of Vendor for all claims arising out of or relating to the performance or breach of the Contract or use of any Products or Services or any order shall not exceed the total Contract price.

17. **FORCE MAJEURE:** Notwithstanding anything contained in the purchase order or any other document relevant thereto, neither party shall be liable for any failure or delay in performance to the extent said failures or delays are caused by the "Act of God" and occurring without its fault or negligence, provided that, force majeure will apply only if the failure to perform could not be avoided by the exercise of due care and vendor doing everything reasonably possible to resume its performance.

A party affected by an event of force majeure which may include fire, tempest, floods, earthquake, riot, war, damage by aircraft etc., shall give the other party written notice, with full details as soon as possible and in any event not later than seven (7) calendar days of the occurrence of the cause relied upon. If force majeure applies, dates by which performance obligations are scheduled to be met will be extended for a period of time equal to the time lost due to any delay so caused.

Notwithstanding above provisions, in an event of Force Majeure, BHEL reserves for itself the right to cancel the order/ contract, wholly or partly, in order to meet the overall project schedule and make alternative arrangements for completion of deliveries and other schedules.

18. **NON-DISCLOSURE AND INFORMATION OBLIGATIONS:** Vendor shall provide with all necessary information pertaining to the goods as it could be of importance to BHEL. Vendor shall not reveal confidential information that may be divulged by BHEL to Vendor's employees not involved with the tender/ contract & its execution and delivery or to third parties, unless BHEL has agreed to this in writing beforehand. Vendor shall not be entitled to use the BHEL name in advertisements and other commercial publications without prior written permission from BHEL.

PONNUGURU PACKIAM  
SR. DGM / CE-MM-PR

P K NAGARAJ  
SR. ENGINEER / CE-MM-PR

PLEASE READ CAREFULLY BEFORE QUOTING. ALSO, IN CASE OF ANY DOUBTS BEFORE QUOTING ,PL CONTACT BHEL-EDN-CE-MM DEPT AND ENGG DEPT AND GET IT CLARIFIED IMMEDIATELY . PL DONOT DELAY THE PROCESS AND BHEL WILL NOT BE RESPONSIBLE FOR ANY DELAY IN YOUR OFFER SUBMISSION AND LATE OFFERS WILL BE REJECTED. ALSO, BHEL WILL NOT EXTEND THE OFFER SUBMISSION DUE DATE. ANY DELAY IN YOUR OFFER SUBMISSION BEYOND DUE DATE AND TIME WILL BE TREATED AS LATE OFFER AND HENCE LATE OFFER WILL BE REJECTED. IF POSSIBLE , PL VISIT BHEL-EDN AND GET THE CLARIFICATION ACROSS THE TABLE.

**1. BHEL will use following criteria for acceptance of technical / commercial offers**

BHEL will evaluate overall L1 based on the total quantity of analysers.

Purchase orders for All Analysers for one/ each project will be placed on one vendor only. BHEL will make efforts to obtain approval of quoted make and models with all customers. In the event any of the customer does not accept quoted makes of successful bidder(s) , then vendor shall supply customer approved make and models at the quoted rates only, without any additional cost implication to BHEL. Hence, pl take care of this point at the time of quoting your unit prices for each of the Analysers.

- 2.. Evaluation of offers / vendors shall be done as per BHEL requirement. **Final acceptance for a given project is dependent upon customer accepting new vendor and (or) make and (or) model during documents approval stage after PO placement.**
3. **Split orders on approx. 75 % of the tender Quantity on L1 and approx. 25 % of the tender Quantity on L2 (at L1 prices) will be placed by BHEL. BHEL has the full right for Project allocation/selection to the L1 & L2 vendors in view of above said reasons and vendors should honour the same.**
4. **Pl note that** all currently known analyser vendors are acceptable to most customers.
5. BHEL will procure all analysers for a given project from one vendor only as said earlier . However exact quantity of analysers to be ordered will depend on vendor approval by customer for each project. BHEL shall put efforts to obtain vendor approval from customer for finally selected vendors and (or) make and (or) model for all projects. In the event, end users/ customers do not approve PQR qualified vendors, a separate procurement action will be initiated for that specific project. BHEL shall proceed with procurement action from customer approved vendors for balance quantity and such quantity for which a separate procurement action need to be taken by BHEL shall be reduced from above RFQ/NIT/PO quantity . **Vendors should maintain the unit prices for each analysers irrespective of the quantity variation.**

6. BHEL will put best effort for approx. one month period from the date of approaching customer for additional vendor approval. If further approvals are not received, then BHEL will proceed with already approved vendors for each project. However BHEL decision is final.

(7) Mandatory Spares(O & M) - Separate Packing should be made with colour coding

(8) Commissioning Spares - Separate Packing should be made with colour coding

This is for easy identification of mats at site . **This will be considered for offer evaluation.**

(9) O & M Manuals: 2 copies are to be submitted . One hard copy alongwith matl, one hard copy along with dispatch documents to BHEL-EDN-Bangalore . Soft copy of O & M Manuals in CD to be submitted to BHEL-EDN-Bangalore along with desp documents.

(10) If vendor is having different alternatives/options for each analysers, all options/alternatives should be indicted in the Technical bid and Price bid of Initial /first submission/before technical bid opening only. After technical bid opening, BHEL will not accept any alternate models/options which are already available with vendors and which as per BHEL opinion ,vendor should have included in the initial/first submission/ before Technical Bid Opening itself. However, BHEL will indicate the chosen model for each vendor before price bid opening/Revers Auction

(11) Payment term - 100% through bank for indigenous supply is NOT Acceptable to BHEL & hence offer will be rejected ,if 100% thro' bank is quoted.

(12) Analyzers - Option- I : Offer in Foreign currency - BHELwill place PO on Original Equipment Manufacturer directly

Option : II - Offer on High sea sale basis for the matl supply from OEM which are outside India and matl to be Imported by BHEL - BHEL will place PO on Indian Vendors in Indian Rupees on CIF,Mumbai basis. BHEL will do customs clearance

Option-III – Offer in Indian Rupees ,on FOR WORKS(any dispatch station in India) basis - BHEL will place PO in Indian Rupees

**Note: Option-III is not preferred by BHEL and hence PI avoid Option-III**

13) BHEL may have (a)Duty free Import License or (b) project Imports with concessional customs Duty or (c) Merit duty depending upon the nature of projects . **BHEL will do the customs clearance.** Hence, during offer evaluation,

duty structure applicable for a project shall be applied and evaluated. Hence for supply from foreign country, HSS or Foreign currency quote is preferred by BHEL

14) Prices should be on FIRM basis only.

15) In Import invoice/HSS doc, Item nomenclature should be in line Import License of BHEL

16) In case a PO on foreign vendor in foreign currency is placed for the supply of all analysers for a project and in turn foreign vendor places PO on his sub vendor for which the model / make is acceptable to BHEL/customer, then All analyser including sub vendors manufactured analysers are to be consolidated at foreign vendor work only on whom BHEL has placed PO and after consolidation of all analysers for a project, consignment to be sent to India, Mumbai as one package/shipment. Part shipment is NOT permitted (For HSS & direct Imports) . For High sea sale PO also, all analysers for a project should be consolidated at foreign vendor work of the Indian counter part on whom BHEL has placed PO and All analyser including sub vendors manufactured analysers are to be consolidated at foreign vendor work only and after consolidation of all analysers for a project, consignment to be sent to India, Mumbai as one package/shipment. Part shipment is NOT permitted

17) Repacking of matl at site by local vendors rep after verification and certification of all matl receipt as per PO/packing list by BHEL/customer staffs is mandatory . **Cost, if any may be quoted in the offer and this cost will be added during offer evaluation of "Total cost to BHEL".**

18) Unit prices quoted in Commissioning Spares & Mandatory Spares shall be valid for 3 years from the date of PO to cater the site complaints /shortages and vendors to honor these unit prices till order execution .

19) Items like PH sensor, DO sensor , Tygon Tubes , Chemical regents etc., to be supplied to BHEL customer only during commissioning of the SWAS at site.. In case of quote for Chemical reagents in foreign currency, a separate line item with prices to be indicated in offer and PO for this Chemical reagents supply portion will be placed separately and only Merit customs duty only will be applied for offer evaluation for all the projects for above mentioned items since BHEL will be paying Merit customs duty only at the time of customs clearance of the consignment. However, for quote in Indian Currency for Items like PH sensor, DO sensor , Tygon Tubes , Chemical regents etc., there will be a separate line item in the PO and matl can be dispatched to site only after Desp clearance from BHEL which will be issued during commissioning of the projects.

20) Follow HSE procedure for handling and shipping/ storing chemical reagents.

(21) It is mandatory that all vendors should quote for this tender. BHEL has taken utmost care to finalise the tender qty for main Analysers and spares. However, Qty variations for main analysers of each type and mandatory spares, commissioning spares cannot be avoided and un expected qty variations may be possible. Hence, it is mandatory that all vendors should quote for this tender. Those vendors who have quoted for this tender only will be intimated for qty variations , changes in specn etc,. At any point of time for what so ever may be the



reasons, BHEL will not contact any other vendor to whom tender has been addressed but not quoted. It is the responsibility of the vendors to get the necessary clarifications from BHEL before quoting. If a vendor do not quote for all analysers, BHEL may reject the offer .

(22) To avail customs duty benefits, HSS options or Foreign currency offer is preferable. Offers in Indian Rupees is not preferable to BHEL .

(23) It is expected that all analysers should be offered by each vendor. In case, one vendor is not manufacturing all analysers, BHEL is prepared to place PO on the manufacturers in foreign currency only indicated by them directly provided they meet technical reqts and accept all the commercial terms agreed by vendor with BHEL. However, the Indian vendors are fully responsible for the entire package of Analysers before and after commissioning of the system.

**24) PBG is a mandatory requirement for these tenders. Vendor(s) who have not agreed for PBG clause , their offers will be rejected.**

25) In case of quoting more than one model for an Analyser with different unit prices, BHEL will consider the lowest model price of the technically acceptable model for offer evaluation. However, in case, customer(s) do not accept the selected model, then vendor has to supply model which is acceptable to customer/BHEL at the same price/cost of the model which has been considered for offer evaluation /PO placement. PO will be amended to indicate the customer /BHEL accepted model without alteration of unit price for that model.

**Enclosure to Special Conditions of Contract (RFQ No.: PKN0000031 )**

| Sl. No. | PROJECT                               | ITEM                                          | LOCATION                         | FOR IMPORTED ITEMS                                                                                                                     | FOR INDI GENOUS ITEMS                                                   |
|---------|---------------------------------------|-----------------------------------------------|----------------------------------|----------------------------------------------------------------------------------------------------------------------------------------|-------------------------------------------------------------------------|
| 1       | SAGARDIGHI<br>(2 X 500 MW)            | ANALYZERS FOR STEAM AND WATER ANALYSIS SYSTEM | SAGARDIGHI,<br>WEST BENGAL       | NIL CUSTOMS DUTY – MEGA PROJECT                                                                                                        | ED NIL, CST IS REIMBURSABLE BY CUSTOMER.                                |
| 2       | DVC BOKARO<br>(1 X 500 MW)            | ANALYZERS FOR STEAM AND WATER ANALYSIS SYSTEM | BOKARO,<br>JHARKHAND             | MERIT DUTY-(0+ 12+ 0+ 4)                                                                                                               | ED, CST / VAT APPLICABLE AT NORMAL RATES.                               |
| 3       | BELLARY (1 X<br>700 MW)               | ANALYZERS FOR STEAM AND WATER ANALYSIS SYSTEM | BELLARY,<br>KARNAKATA            | MERIT DUTY-(0+ 12+ 0+ 4)                                                                                                               | ED, CST / VAT APPLICABLE AT NORMAL RATES.                               |
| 4       | YERMARUS (2<br>X 800 MW)              | ANALYZERS FOR STEAM AND WATER ANALYSIS SYSTEM | RAICHUR,<br>KARNAKATA            | MERIT DUTY-(0+ 12+ 0+ 4)                                                                                                               | ED & CST/VAT ARE APPLICABLE AT NORMAL RATES & REIMBURSABLE BY CUSTOMER. |
| 5       | FARAKKA R &<br>M (2 X<br>500MW)       | ANALYZERS FOR STEAM AND WATER ANALYSIS SYSTEM | KOLKATA, WEST<br>BENGAL          | MERIT DUTY-(0+ 12+ 0+ 4)                                                                                                               | ED, CST / VAT APPLICABLE AT NORMAL RATES.                               |
| 6       | SINTEX<br>INFRA(2X150)                | ANALYZERS FOR STEAM AND WATER ANALYSIS SYSTEM | DHULE,MAHARAS<br>TRA             | MERIT DUTY-(0+ 12+ 0+ 4)                                                                                                               | ED,CST ARE APPLICABLE AT NORMAL RATES & REIMBURSABLE BY CUSTOMER.       |
| 7       | SINGARENI (2<br>X 600 MW)             | ANALYZERS FOR STEAM AND WATER ANALYSIS SYSTEM | MANCHERYAL,<br>ANDHRA<br>PRADESH | MERIT DUTY-(0+ 12+ 0+ 4)                                                                                                               | ED, CST / VAT APPLICABLE AT NORMAL RATES.                               |
| 8       | LALITPUR (3 X<br>660 MW)              | ANALYZERS FOR STEAM AND WATER ANALYSIS SYSTEM | JHANSI, UTTAR<br>PRADESH         | MERIT DUTY : 0+ 12+ 0+ 4<br>If BG / Mega Certificate received from customer then Custom duty NIL.<br>FREIGHT REIMBURSABLE BY CUSTOMER. | ED NIL, CST/VAT, FREIGHT ARE REIMBURSABLE BY CUSTOMER.                  |
| 9       | OPG KUTCH -<br>2 X 150 MW             | ANALYZERS FOR STEAM AND WATER ANALYSIS SYSTEM | KUTCH,GUJARAT                    | MERIT DUTY-(0+ 12+ 0+ 4)                                                                                                               | ED,CST ARE APPLICABLE AT NORMAL RATES & REIMBURSABLE BY CUSTOMER.       |
| 10      | APGENCO<br>RAYALSEEMA -<br>1 X 600 MW | ANALYZERS FOR STEAM AND WATER ANALYSIS SYSTEM | KADAPA,ANDHRA<br>PRADESH         | MERIT DUTY-(0+ 12+ 0+ 4)                                                                                                               | VAT IS APPLICABLE AT NORMAL RATES & REIMBURSABLE BY CUSTOMER.           |
| 11      | 30 TH BHEL<br>HYD                     | ANALYZERS FOR STEAM AND WATER ANALYSIS SYSTEM | BHEL,HYDERABAD                   | MERIT DUTY-(0+ 12+ 0+ 4)                                                                                                               | ED, CST / VAT APPLICABLE AT NORMAL RATES.                               |