

1

POWER SMART GUIDE:  
Energy saving solutions for home comfort

# Sealing, caulking and weatherstripping



 **Manitoba  
Hydro**  
POWER SMART<sup>®</sup>

\*Manitoba Hydro is a licensee of the Trademark and Official Mark.

# Metric Conversion Factors

## A. Converting Imperial Units into Metric Units

Unit	Conversion	Multiply By
Thermal Resistance	R values to RSI values	0.1761
Length	inches to millimetres	25.40
	inches to centimetres	2.540
	feet to metres	0.3048
Area	square feet to square metres	0.09290
Volume	gallons to litres	4.546
	cubic feet to cubic metres	0.02832
Mass	pounds to kilograms	0.4536
Density	pounds/cubic feet to kilograms/cubic metre	16.02

## B. Converting Metric Units into Imperial Units

Unit	Conversion	Multiply By
Thermal Resistance	RSI values to R values	5.678
Length	millimetres to inches	0.03937
	centimetres to inches	0.3937
	metres to feet	3.281
Area	square metres to square feet	10.76
Volume	litres to gallons	0.2200
	cubic metres to cubic feet	35.31
Mass	kilograms to pounds	2.205
Density	kilograms/cubic metre to pounds/cubic foot	0.06243

If you are uncertain of, or have any question or concern regarding, any subject matter herein or the safety and/or proper handling of any material(s) and/or product(s) that you may encounter in your undertaking, please consult resources such as Health Canada (Health Links) @ 1-888-315-9257, the Manitoba Department of Labour @ 1-800-282-8069, or (Canada Mortgage & Housing Corp.) @ 1-800-668-2642.

The information contained herein is published as a convenient reference for Manitoba Hydro's customers. While every effort has been made to provide accurate and complete information, Manitoba Hydro does not warrant the accuracy or efficacy thereof. Manitoba Hydro will not be liable for any loss, costs, damage or injury whatsoever, resulting from the use of this material.

Cette information est également disponible en français.

BOOKLET #1

# Sealing, caulking & weatherstripping

# Contents

## Introduction

Why retrofit?	1
Do it yourself or hire a contractor	1

## Basic principles

How to locate air leaks	2
Air leakage location checklist	3
Can you overseal your home?	7
Material selection	
• Sealant	8
• Weatherstripping	12

## Reducing air leakage

Windows	
• Interior trim	14
• Single-hung windows	16
• Sliding windows	19
• Casement, awning or hopper windows	20
• Exterior storm windows	23
Doors	
• Interior trim	24
• Gaps in doors	24
• Jambs	25
• Sills	25
• Sliding doors	25
• Storm doors	25
Exterior walls	
• Electrical switches and outlets	27
• Junction of the floor and exterior walls	27
• Cracks in the wall finish	29

Attics	
• Attic hatches	29
• Plumbing stack	29
• Electrical wires and light fixtures	31
• Recessed light fixtures	31
• Exhaust fans and ducts	33
• Junction of the ceiling and interior partitions	33
• At the top of interior and exterior walls	33
• Chimneys	33
• Half-storey attics	35
• Foundations	35
• Junction of the floor and foundation	35
• Cracks in walls and floors	35
• Floor drain	37
• Miscellaneous gaps and openings	37

## Tables

Table 1 — Types of sealants	39
Table 2 — Weatherstripping materials	41
Table 3 — Weatherstripping door bottoms	44

# Introduction

## Why retrofit?

**Save money** — Heating a home, especially in our climate, can be expensive. Sealing a house to reduce air leakage is often the least expensive way of achieving significant savings on your heating bill.

**Increase comfort** — A thorough job of sealing and weatherstripping will reduce cold drafts and make your home more comfortable.

**Conserve energy** — Approximately 13 per cent of Manitoba's annual energy use goes to heat our homes. Much of that energy can and should be saved. Retrofitting your home will help save our valuable energy resources at a cost lower than producing new energy supplies.

**Help the environment** — Making your home more energy efficient means reducing greenhouse gas emissions, which is good for the environment.

In addition to these major benefits, retrofitting often can also improve the appearance, longevity and safety of your home.

## Do it yourself or hire a contractor

This booklet has been designed to meet the needs of both the experienced and the inexperienced “do-it-yourself-er”. Most of the work described can be done by a homeowner with common household tools. By doing it yourself, both the savings and job satisfaction can be high. Please read this booklet carefully. For additional help, please contact us (see inside front cover), or contact your local building material supplier.

If you intend to have a contractor do some or all of the work, this booklet will still be of interest to you. You are more likely to get the results you want if you are knowledgeable about the work and take an active interest in what the contractor does. For further information on how to hire a contractor, call the Consumer Protection Office at (204) 945-3800 (Winnipeg), 1-800-782-0067 or email [consumers@gov.mb.ca](mailto:consumers@gov.mb.ca).

Whether you do it yourself or hire a contractor, please remember that this booklet does not describe every possible technique for sealing, caulking and weatherstripping a home. *Each home is unique, and you or your contractor may find it necessary or desirable to use techniques that are not shown in this booklet.*

# Basic principles

## How to locate air leaks

The first step in sealing and weatherstripping is to determine where the air is leaking into and out of your home. One way to detect these air leaks is to make a **draft detector**, as shown in **Figure 1**. When held steady in the path of a draft, the plastic or tissue will flutter.

Smoke pencils, specially designed to identify leaks and drafts, are commercially available. As an alternative, you may prefer to use the smoke from an incense stick as your indicator.

Air leakage is best detected when the air pressure difference between the inside of the house and the outdoors is greatest. Choose a cool, windy day in the fall or a cold winter day. Turn on all exhaust fans (including the clothes dryer) that are vented to the outdoors to increase the air leakage.

Move your draft indicator around window and door edges, electrical outlets and other potential sources of air leaks identified in this booklet. Mark the drafty spots with a piece of a chalk and use the **Air leakage location checklist** on pages three to six to record the results of your test. Refer to the appropriate sections of this booklet for advice on how to choose the right materials and techniques to seal or weatherstrip each air leak.

**Figure 1**

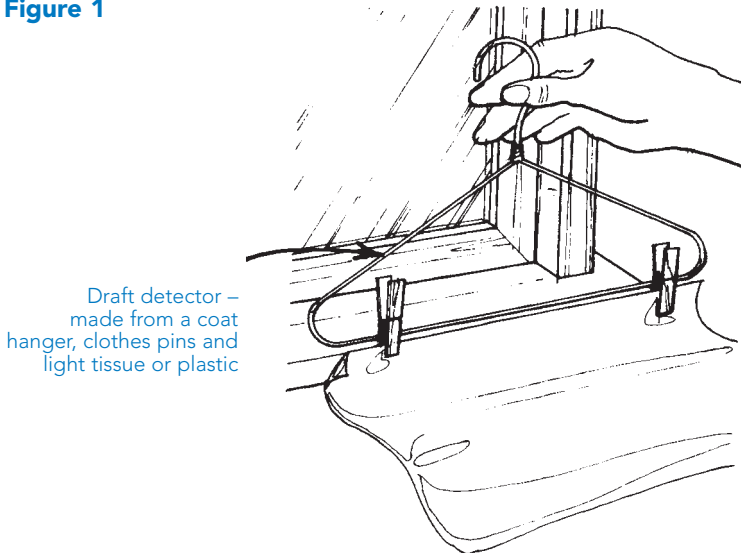

Draft detector –  
made from a coat  
hanger, clothes pins and  
light tissue or plastic

# Air leakage location checklist

S — Satisfactory

X — Improvements needed

XX — Serious problem

	Living room	Kitchen	Dining room	Bedroom #1	Bedroom #2	Bedroom #3
<b>Windows</b>	Interior trim					
	Around panes of glass					
	Around operating sash					
	Hardware (locks, cranks)					
<b>Exterior doors</b>	Interior trim					
	Weatherstripping					
	Threshold					
<b>Attic</b>	Attic hatch					
	Plumbing stack					
	Electrical wires					
	Light fixtures					
	Recessed lights					
	Bathroom vent					
	Kitchen vent					
	Tops of walls					
	Chimneys					
	Drop ceilings					



Bedroom #4	Bathroom #1	Bathroom #2	Family room	Utility room	Basement				
									Interior trim
									Around panes of glass
									Around operating sash
									Hardware (locks, cranks)
									Interior trim
									Weatherstripping
									Threshold
									Attic hatch
									Plumbing stack
									Electrical wires
									Light fixtures
									Recessed lights
									Bathroom vent
									Kitchen vent
									Tops of walls
									Chimneys
									Drop ceilings

Continued on next page

# Air leakage location checklist

S — Satisfactory  
 X — Improvements needed  
 XX — Serious problem

	Living room	Kitchen	Dining room	Bedroom #1	Bedroom #2	Bedroom #3
<b>Walls (including basement)</b>	Switch covers					
	Outlet covers					
	Baseboards					
	Wall cracks					
	Bathtub/shower					
	Exhaust fans					
	Top of foundation wall					
	Dryer vent					
	Telephone cable					
	Television cable					
	Electric service cable					
	Natural gas pipe					
	Exterior faucets					
	Mail slot					
	Fireplace/wall joint					
<b>Misc.</b>	Fireplace damper					
	Basement floor cracks					
	Basement floor drain					
	Air conditioner pipes					

Bedroom #4	Bathroom #1	Bathroom #2	Family room	Utility room	Basement					
										Switch covers
										Outlet covers
										Baseboards
										Wall cracks
										Bathtub/shower
										Exhaust fans
										Top of foundation wall
										Dryer vent
										Telephone cable
										Television cable
										Electric service cable
										Natural gas pipe
										Exterior faucets
										Mail slot
										Fireplace/wall joint
										Fireplace damper
										Basement floor cracks
										Basement floor drain
										Air conditioner pipes

## Can you overseal your home?

If the air in a house contains any substance in quantities large enough to constitute a health hazard or source of discomfort to the occupants, or a threat to the structure of the house, then the house is said to have poor indoor air quality.

Although difficult, it is possible in some cases to seal a house to the point that air quality problems occur. Potential problems include:

- Humidity levels in the house during the heating season may become excessive.
- The concentration of pollutants in the house's air may rise to unhealthy levels.
- Fuel burning appliances (e.g. fireplaces, natural gas furnaces or hot water tanks, etc.) may not receive an adequate supply of air to function properly.

The following is an overview of indoor air quality issues. For more details, refer to Booklet #8: Indoor air quality & ventilation.

**Humidity levels** — Low humidity levels in your home during the heating season may cause static electricity, dust and dryness of the skin and throat. Sealing and weatherstripping will increase humidity levels and reduce these problems.

On the other hand, you may find that your home's humidity levels during winter are already too high. This encourages the growth of moulds, spores, etc. and can create health problems for some people. Excessive humidity levels may also cause significant damage to the structure of the house.

Relative humidity can be measured quite easily using a hygrometer, available from building supply centres or electronics stores. For health reasons, the relative humidity in your home should be kept above 30 per cent. During our coldest weather, condensation may form on windows when interior relative humidity is above 30 per cent.

If your home has excessive humidity levels, it is recommended that this problem be solved before undertaking any sealing or weatherstripping. For publications on how to solve a humidity problem, see the inside front cover for ordering information.

**Pollutants** — The air in a house contains numerous pollutants. As concentrations of these pollutants increase, the occupants' health or comfort will start to be affected. The safe concentration limit varies considerably from one type of pollutant to another and from one person to another.

There is no simple and conclusive test to identify whether the concentration of pollutants is too high. It is also hard to predict whether sealing and weatherstripping will create a problem. Fortunately, in most cases it is extremely difficult to seal a home to the point where airborne pollutants become a problem if the home has an effective ventilation system.

If you plan to do an extensive job of sealing and weatherstripping, ensure that your home is equipped with an adequate ventilation system.

**Fuel burning appliances** — Air is required by fuel burning appliances for the efficient burning of fuel and to remove the resulting combustion by-products up the chimney or flue.

In some homes, fuel burning appliances are provided with their own air supply ducted directly from the outdoors. In these cases sealing or weatherstripping will not affect the performance of the appliance.

Older fuel burning appliances are not provided with their own supply of air from the outdoors. If you plan an extensive job of sealing and weatherstripping in this situation, have a heating contractor ensure that any fuel burning appliances in the home are provided with an adequate supply of air.

## Material selection

### Sealant, Caulking - what is the difference?

The terms "caulk", "caulking" and "sealant" are often used interchangeably, since these materials are all used to fill gaps and cracks between building materials. Caulk is an older term used to describe material in joints, and is usually fairly rigid when dry. Sealant is a broader term, which includes caulking, flexible caulking and single component expanding foam.

### Sealant

A sealing compound is applied to reduce air leakage where two surfaces meet but do not move. Although the application of sealant may require a little more effort and skill than weatherstripping, it is just as important in cutting heat loss from your home.

A proper job of sealing requires that you:

- select the correct sealant for the job,
- properly prepare the surface to which the sealant will be applied,
- properly apply the sealant.

The effectiveness of the sealing job is dependent on these three steps.

## Selection of material

Many homeowners have unfortunate experiences when they first try sealing because they purchase an inexpensive or inappropriate sealant. These sealing materials might be effective at first, but more often than not they fail, wasting your time and money.

**Table 1** describes the types of sealants that are commonly available. Be sure to select a good quality product that is appropriate for the task.

Staff at a hardware store or building supply centre can help you with your selection.

## Surface preparation

A properly prepared surface is essential if the sealant is to provide an effective, long-lasting seal.

Use a wire brush, sandpaper or scraper and a clean cloth to remove dirt, loose material, old paint, old caulking, etc. from the joint to be sealed.

With some types of sealants, further preparation of the surfaces (i.e. priming) may be required. Always follow the manufacturer's recommended surface preparation.

**Figure 2**

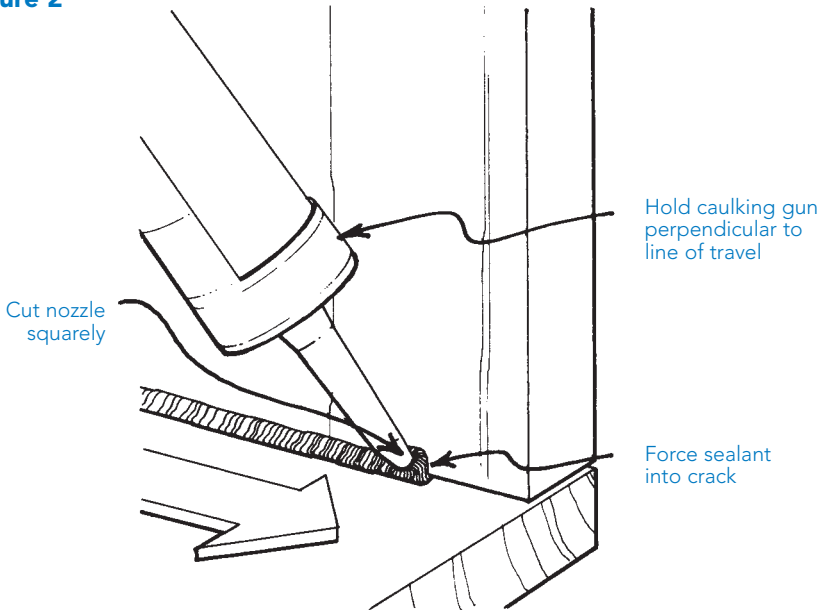

## Application of sealant

Before applying any sealant, always read the label to determine whether the product is flammable, or a skin/respiratory system irritant, and handle accordingly.

Most of the materials listed in **Table 1** come in 310 ml (11 oz) tubes and can be applied with a simple, inexpensive caulking gun. Some of the sealants also come in 810 ml (28 oz) tubes but require a larger, more expensive caulking gun.

Cut the nozzle of the tube of sealant squarely and at a size that will allow the bead of sealant to overlap both sides of the crack. Hold the gun perpendicular to the line of travel to force sealant into the crack (see **Figure 2**). Practice (in an out-of-view location) will probably be required before you can create a neat, uniform bead. Remember to release the pressure lever on the gun to prevent dripping as you move from place to place.

When sealing gaps larger than 10 mm ( $3/8$  inch), it is good practice to use a back-up material such as ethafoam rod (see **Figure 3**). This reduces the amount of sealant required and ensures that the sealant comes into good contact with the sides of the gap. Larger gaps can also be sealed with urethane foam (spray foam).

Details of where to apply sealants are given in later sections of this booklet.

**Figure 3**

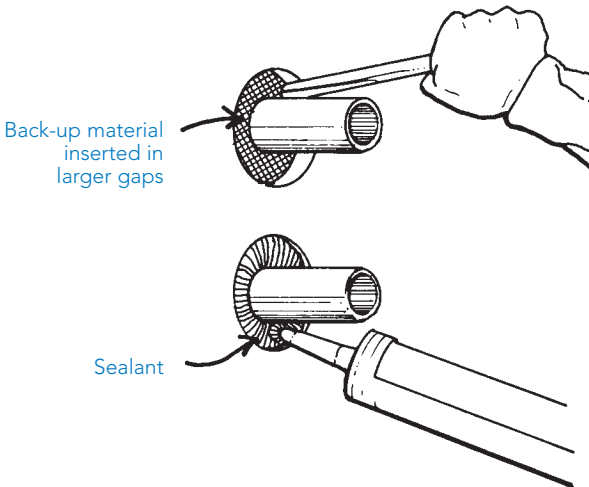

## Tooling the bead

If the bead of sealant will not be covered by trimwork, you may want to tool the bead to improve its appearance. Running a wet finger lightly along the surface of the bead is often the most effective technique.

Note, however, that with some sealants, skin contact should be avoided. In these cases, it may be possible to tool the bead with a plastic spoon or specially designed tools intended for this purpose — refer to the manufacturer's instructions.

## Clean-up

Have a rag handy to wipe off any excess sealant. Latex caulking can be cleaned off with water before it sets. For other sealing materials, try a standard solvent (e.g. mineral spirits, turpentine, rubbing alcohol). Cover adjoining areas with masking tape to minimize the chance of marring the finish.

To store the sealant, release pressure on the tube by pulling back the plunger of the gun. Wipe the tip of the tube clean, cap it tightly and store in a cool, dry place.

## Foam sealant

Foam sealants are ideally suited to deal with larger gaps. In addition to reducing air leakage, they also provide insulation. They are available in single component and two component systems, and range in size from small disposable cans to propane cylinders.

Single component foams are best suited for gaps less than 25 mm (1 inch). Cans with a straw that fits into the nozzle are inexpensive, but it can be difficult to control the foam coming out. Foam guns, which accommodate screw-in canisters, are more costly, but allow you to control the foam from a pencil-thin line up to a 1 inch bead.

Two component foam systems involve two containers, a hose, and a nozzle. Foam from the containers mixes in the nozzle and sprays out. They are meant for larger areas like joist header spaces, or filling the space below an attic knee wall.

The foam expands as it is placed, so it takes practice to get the right size of bead. Before you begin your project, start by dispensing some foam onto a scrap piece of plastic, gypsum board or cardboard. Once you're comfortable working with the foam, fill the gaps you're trying to seal, but leave room for the foam to expand. Once the foam has cured, trim off any excess material.



## Weatherstripping

Weatherstripping is used to control air leakage at joints where two surfaces meet and move relative to each other such as doors, windows and attic hatches.

As with sealing, a proper weatherstripping job requires that you select the correct material, adequately prepare the surfaces to which the weatherstripping will be applied, and properly install the material.

### Selection of weatherstripping

Common types of weatherstripping are described in **Table 2**.

The weatherstripping you choose for a particular application should:

- provide an effective seal,
- be durable,
- be relatively easy to install; and,
- have an acceptable appearance.

### Surface preparation

A properly prepared surface is essential if the weatherstripping is to provide an effective, long-lasting seal.

Surface preparation involves several steps but in most cases it is relatively quick and easy. Materials to be weatherstripped should be thoroughly cleaned to remove dirt, oil, grease, flaking paint, wood splinters, etc.

Uneven surfaces should be levelled with a hand plane or sander. Major gaps or cracks should be filled with a latex wood filler.

Before weatherstripping windows and doors, any major structural flaws (warped frames, missing stops, etc.) should be repaired or trued.

Finally, for adhesive-backed weatherstrips, the surfaces should be completely dry before application.

### Application of weatherstripping

Most weatherstripping can be easily installed with the use of standard tools such as a hammer, screwdriver and staple gun. Some materials also require cutting tools. Metal thresholds, door bottoms, and attachment strips are cut with a hacksaw, for instance.

Weatherstripping can be installed throughout the year, but temperature will affect the installation of certain materials. In some cases, weatherstripping installed during warmer months may have to be adjusted to maintain a good seal when sub-zero temperatures are encountered.

As a general rule, adhesive materials used in weatherstripping products are not affected by extremes in temperature. However, while most adhesive-backed materials are meant to be installed without additional fastening, it is a good idea to reinforce the seal with staples every 150 mm (6 inches).

Weatherstripping should be installed in continuous pieces with minimal splices. Materials should butt tightly at corners.

If there is a possibility of air leakage through the gap between the weatherstripping and the surface it is applied to, apply a small bead of sealant under or against the weatherstripping (see **Figure 4**).

Details on where to apply weatherstripping materials are provided later in this booklet.

**Figure 4**

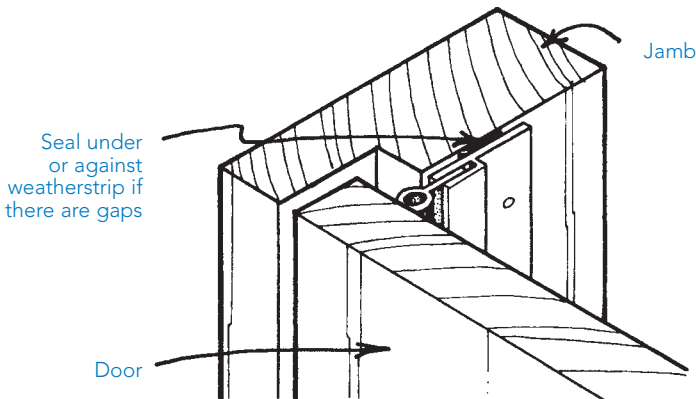
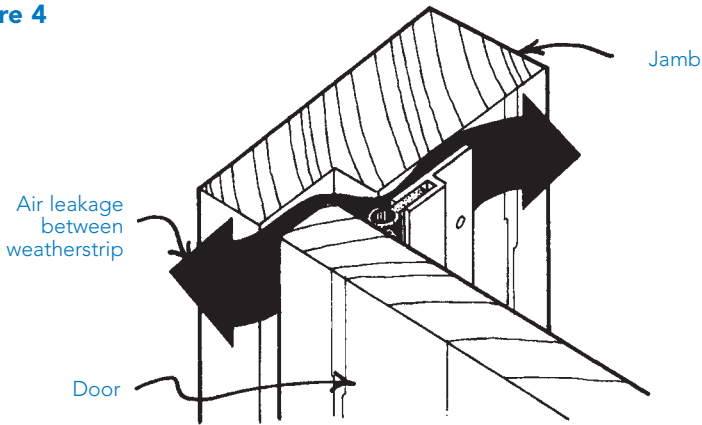

# Reducing air leakage

## Windows

**Interior trim** — Run a continuous bead of clear or paintable sealant along the gap between the trim and wall, as shown in **Figure 5**. Similarly, run a bead along any gap between the trim and window frame and the trim mitre joints.

It is also possible to seal behind the trim, if the previous technique is unacceptable on aesthetic grounds. Carefully remove the trim to expose the gap between the window and the wall. For smaller gaps, sealant can be applied between the window framing and the wall finish (gypsum board, plaster, etc.). For larger gaps, the gap between the window frame and the studs can be sealed with foam sealant (see **Figure 6**). Be sure to allow for expansion of the foam, and trim the excess if necessary.

**Figure 5**

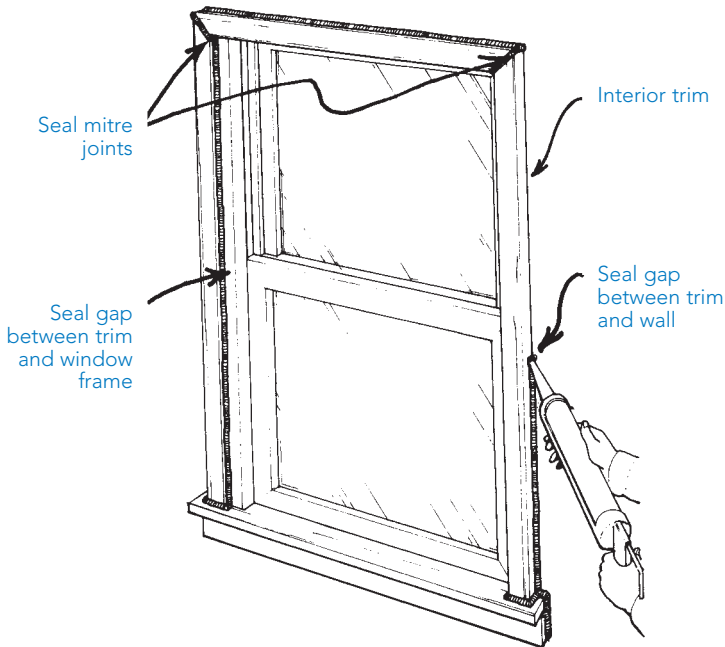
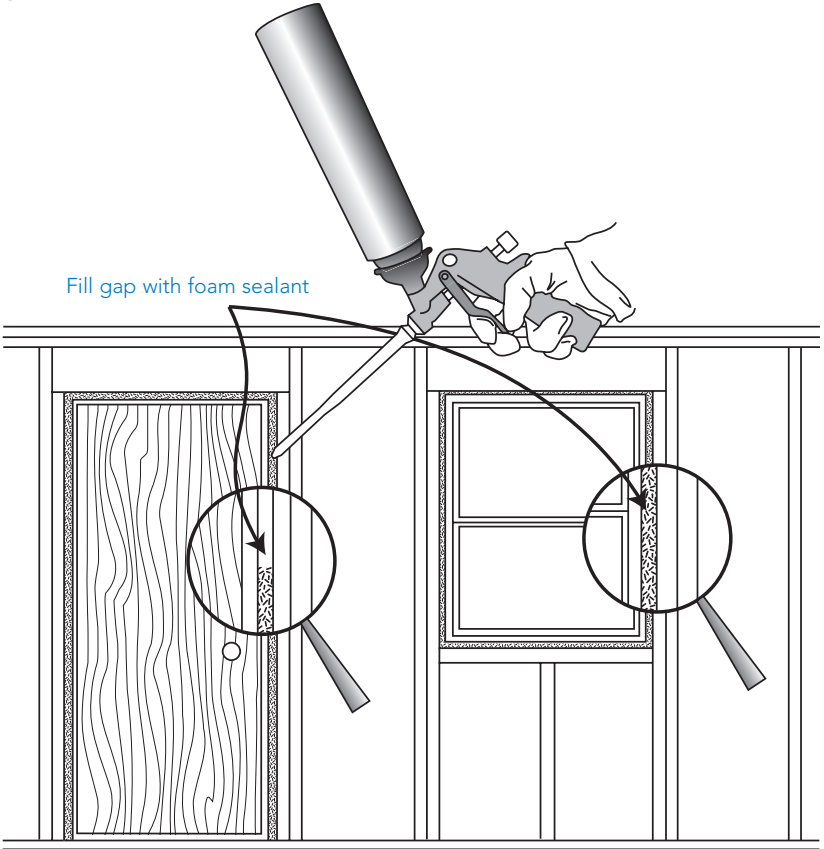
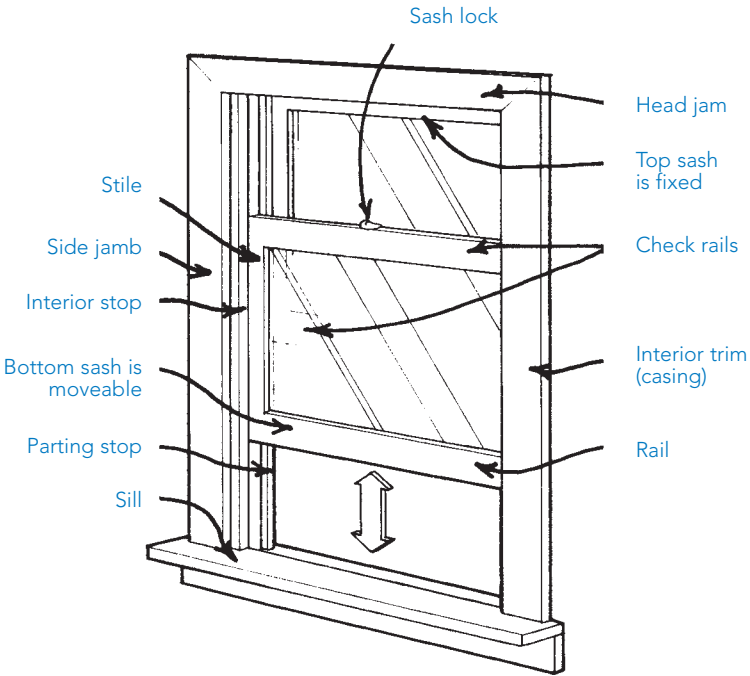

Figure 6



**Figure 7**



**Single-hung windows** — Single-hung wood windows are very common in older homes. They have one fixed and one moveable sash, as illustrated in **Figure 7**.

To seal the fixed sash, apply a continuous bead of clear or paintable sealant along cracks between the sash and stops. If the cracks are very small, seal them by applying a new coat of paint to the sash and window frame.

To seal the moveable sash, carefully remove the interior stops and the sash. Plane the sash, if necessary, to make room for the weatherstripping. Apply adhesive-backed plastic “V” weatherstrip and compression-type weatherstrip, as shown in **Figure 8**. Re-install the sash and replace the interior stops. Check to ensure that the window can still be opened easily. If not, apply a dry lubricant and adjust the stops.

**Figure 8**

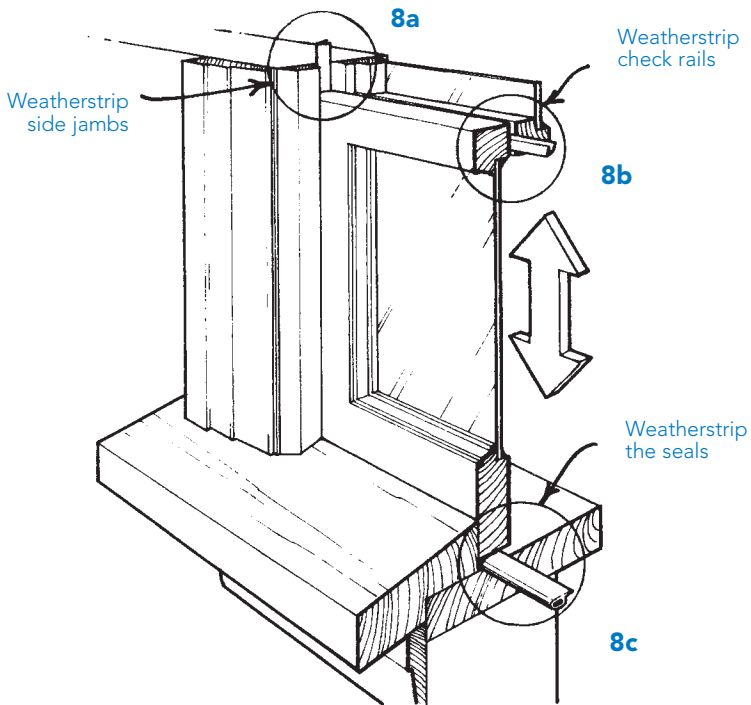

See detail on following page.

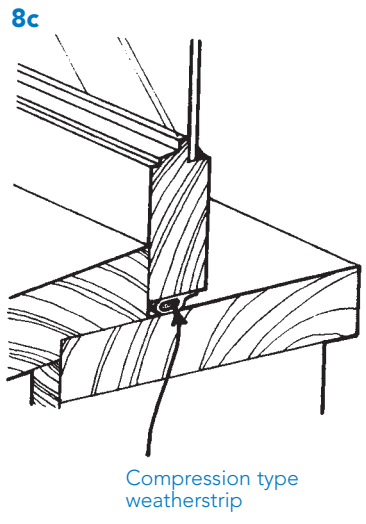
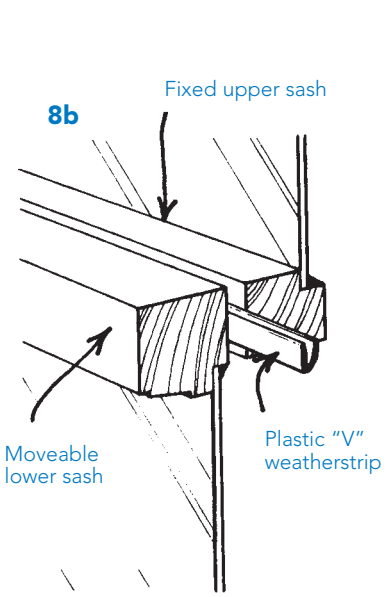
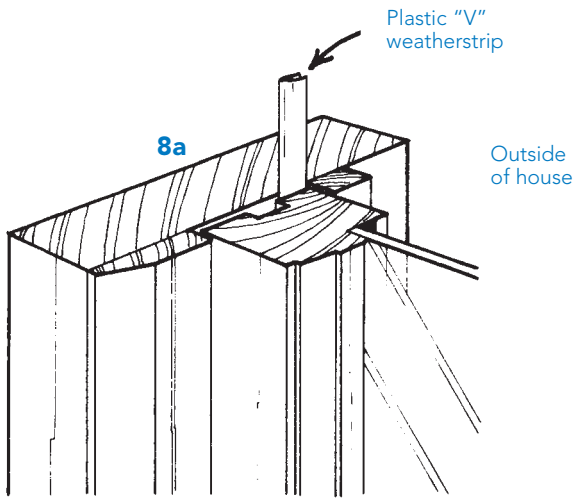

The moveable sash in windows that do not need to open for ventilation or as a fire exit, can be sealed in a similar manner as a fixed sash.

**Sliding windows** — Most sliding windows and doors are supplied with pile weatherstripping. The pile is normally held in place by a flange that is inserted in a slot or groove in the sash or track, as illustrated in **Figure 9**. Newer pile weatherstripping incorporates a plastic ‘fin’ into the pile, which reduces air flow through the weatherstripping.

To obtain the proper size of replacement weatherstripping, take a sample to a weatherstripping supplier or the window manufacturer.

Remove existing pile weatherstrip by carefully pushing a screwdriver blade under the weatherstrip at a corner. Beginning with this free edge, use pliers to pull out the full strip.

**Figure 9**

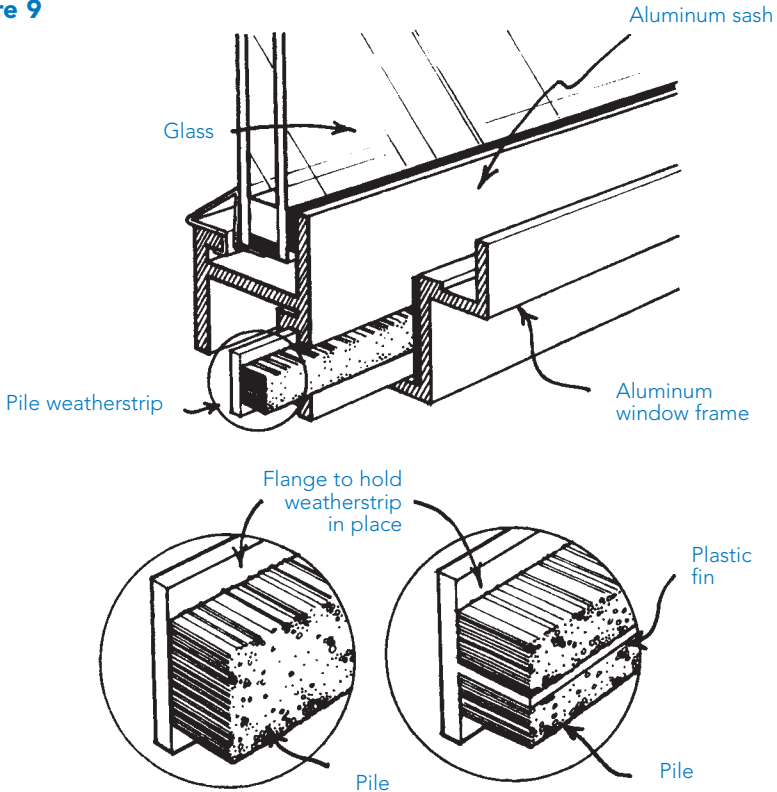



Cut the replacement pile weatherstrip with mitred corners to ensure a close fit at the corners. Snap the weatherstrip into place.

There are many types of sliding windows and doors, so you may need to be innovative. For example, windows that cannot be properly weatherstripped can be sealed with “seal-and-peel” sealant or weatherstripping tape that is applied in the fall and removed in the spring. Note: For safety reasons, bedroom windows must be able to open at all times.

**Casement, awning or hopper windows** — There are three common types of hinged windows, as shown in **Figure 10**.

With these types of windows, considerable improvement in the window’s seal against air leakage can often be achieved by adjusting or replacing ineffective sash locks, or in some cases by installing additional sash locks on large windows. Repair of other defective hardware such as hinges can also reduce air leakage.

**Figure 10**

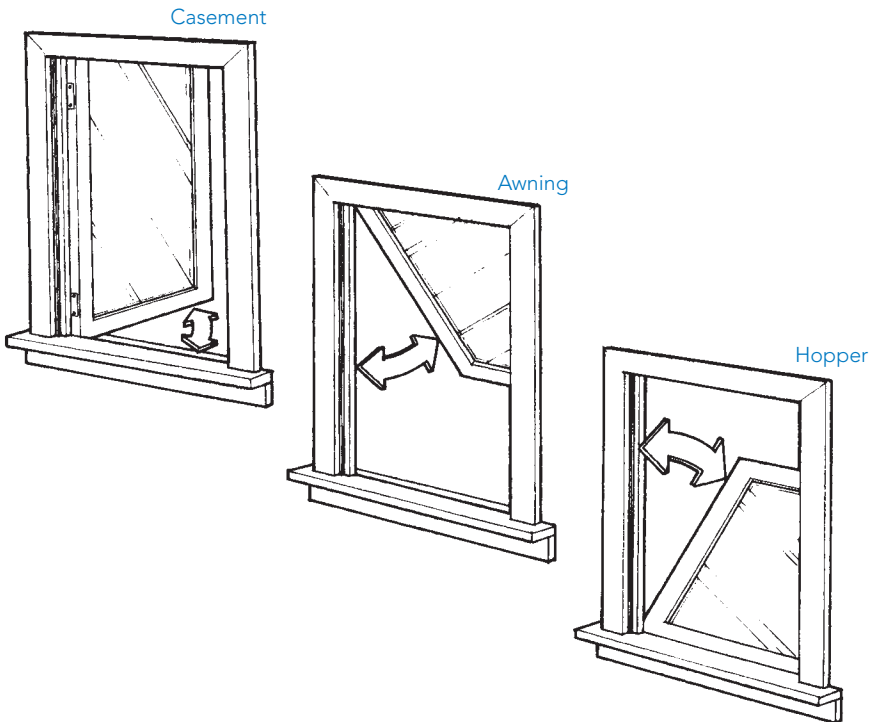

If the original weatherstripping was ineffective or if the window has no weatherstripping, consider the options shown in **Figure 11**.

New windows often have double weatherstripping. This concept can be applied when upgrading existing windows. For hinged windows, put one strip of weatherstripping on the edge of the sash that moves and another compression strip attached to the window frame on the inside.

**Figure 11**

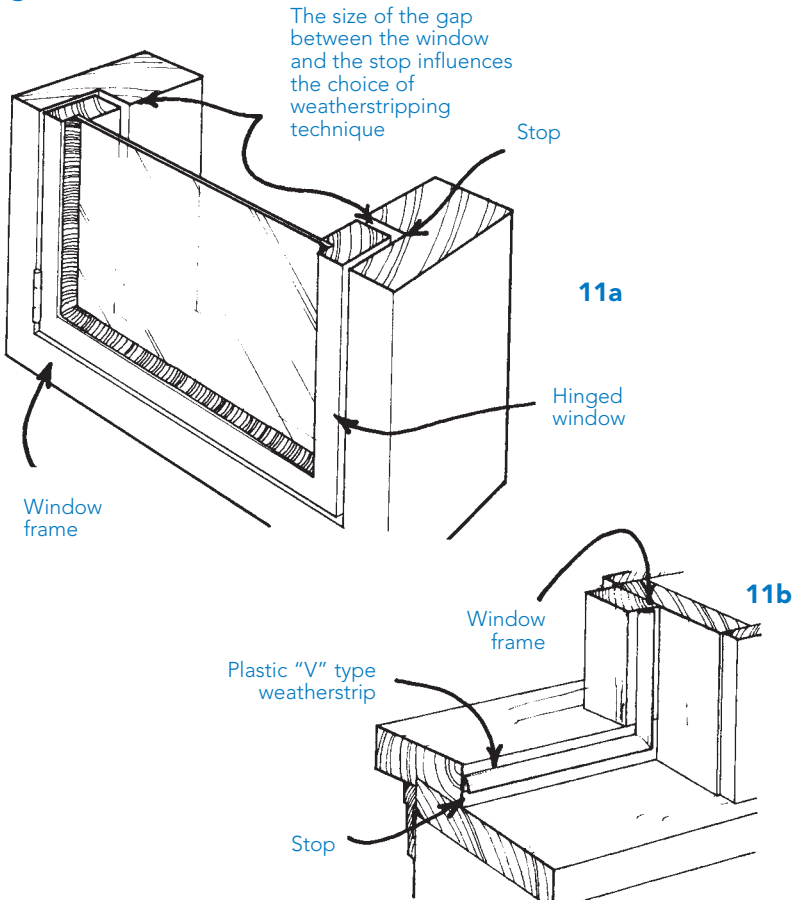

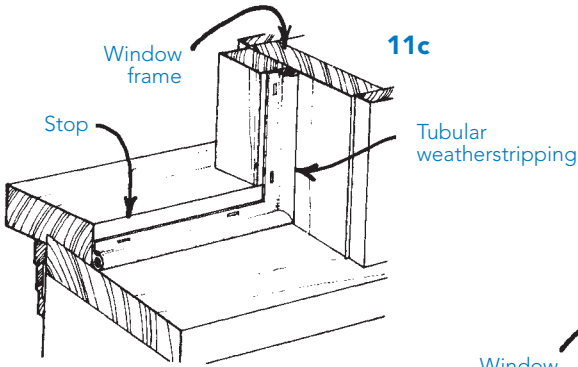

**11c**

Window frame

Stop

Tubular weatherstripping

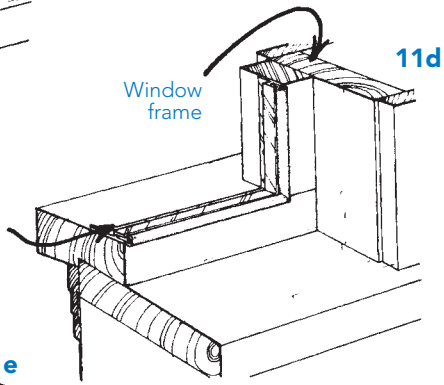

**11d**

Window frame

Tubular weatherstripping mounted in a vinyl or metal strip

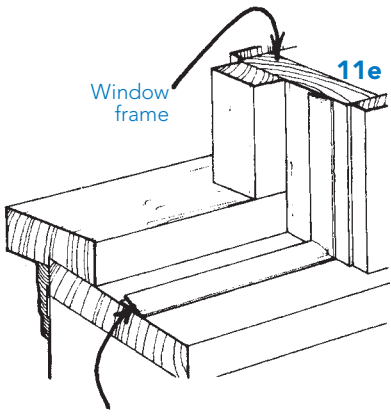

**11e**

Window frame

High quality plastic "V" type weatherstripping applied to give an edge seal

**Exterior storm windows** — Storm windows are often in poor condition. Cracks in the sash and loose panes of glass should be dealt with first. If the weatherstripping on the storm window has deteriorated, install matching replacement seals. If there is no weatherstripping, seal the storm window with weatherstripping, as shown in **Figure 12**.

**Figure 12**

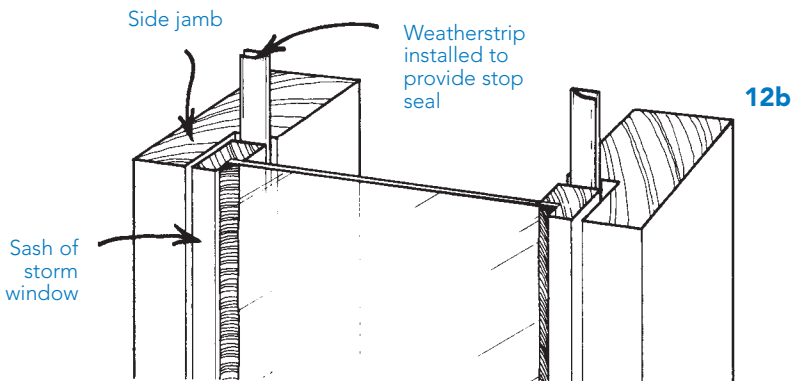
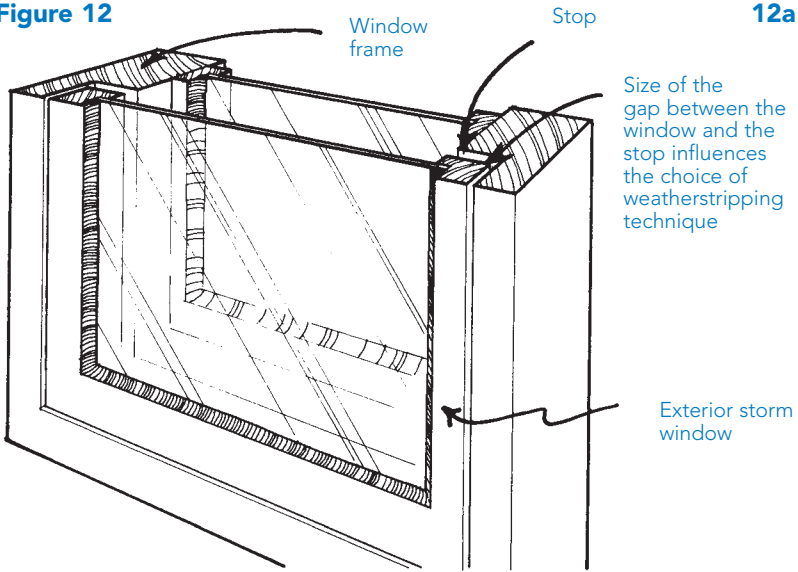

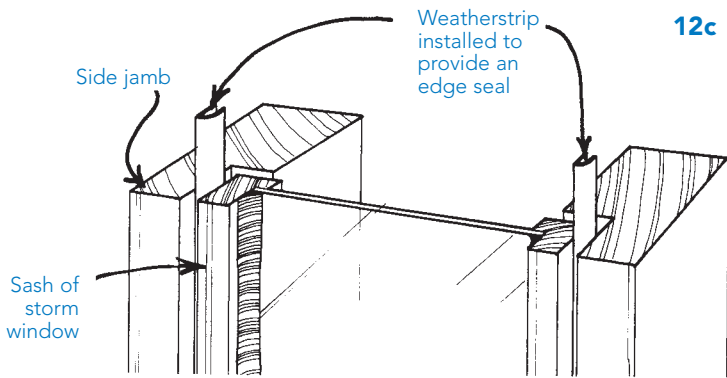

It is important that the exterior storm window not be sealed more tightly than the main window unit. This is to prevent moist house air from being trapped between the main window and the storm window, causing condensation build-up on the storm window.

To avoid trapping moisture, the seal on the storm window unit should be made slightly imperfect by leaving small gaps in the weatherstripping at each corner. The main window unit should be properly sealed or weatherstripped before you weatherstrip the storm unit.

## Doors

**Interior trim** — Gaps between the trim and the wall as well as the trim and the door frame can be sealed the same way as previously described for interior trim around windows (see Page 14).

Since door frames and trim are subjected to considerable vibration from repeated opening and closing of the door, use only high quality sealants to seal any gaps.

**Gaps in doors** — There can be a significant amount of air leakage through the door itself. Repair and seal loose structural joints in the door. Seal any loose panes of glass in the door.

Air leakage can also occur through hardware in the door including the door knob, lock and mail slot. Where practical, devise a technique to seal these components.

**Jamb**s — The width of a gap between the door and the jambs or frame can vary considerably around the door. The gap may also vary considerably from season to season due to warping of the door and settlement of the house.

It is important to select weatherstripping that can accommodate this movement without requiring excessive force to close the door. It is also important that the weatherstripping not become rigid and ineffective at low temperatures. The most common jamb weatherstripping consists of a polyclad foam, mounted on a vinyl, wood, or aluminum carrier. The weatherstripping is flexible to create a tight seal, even if the gap between the door and frame varies.

Various options for sealing the gap between the door and the jambs are illustrated in **Figure 13**. If the door is already fitted with custom-made weatherstripping, try to obtain a replacement set from a weatherstripping supplier or the door manufacturer.

**Sills** — The gap between the bottom of the door and the sill can be weatherstripped with a threshold seal, door bottom seal, or a sweep. Different types of weatherstripping for door bottoms commonly available are described in **Table 3** and illustrated in **Figure 14**.

If the gasket in an existing threshold is worn out, try to purchase and install a new insert. If the whole threshold must be replaced, select one with replaceable gaskets and good resistance to the damaging effects of steady pedestrian traffic. Also give preference to a threshold that does not require trimming the door.

Door bottoms or sweeps are usually installed on doors with no existing bottom weatherstripping. Use door bottoms or sweeps that can be adjusted to compensate for wear and movement.

**Sliding doors** — These can usually be sealed by using the same techniques outlined for sliding windows (see Page 19).

Some types of patio doors require special weatherstripping and installation tools. In these cases, it is advisable to have the work done by a specialist who is familiar with the particular door type.

**Storm doors** — Sealing work should be concentrated on the main doors, leaving the storm doors as unsealed units. It is not advisable to seal both the main and storm doors, since this creates an air lock that makes it harder to close the main door.

Leaving the storm doors unsealed has a low heat loss penalty. The principal functions of a storm door are to protect the main door from weather effects in winter and to serve as a ventilation opening in summer.

**Figure 13**

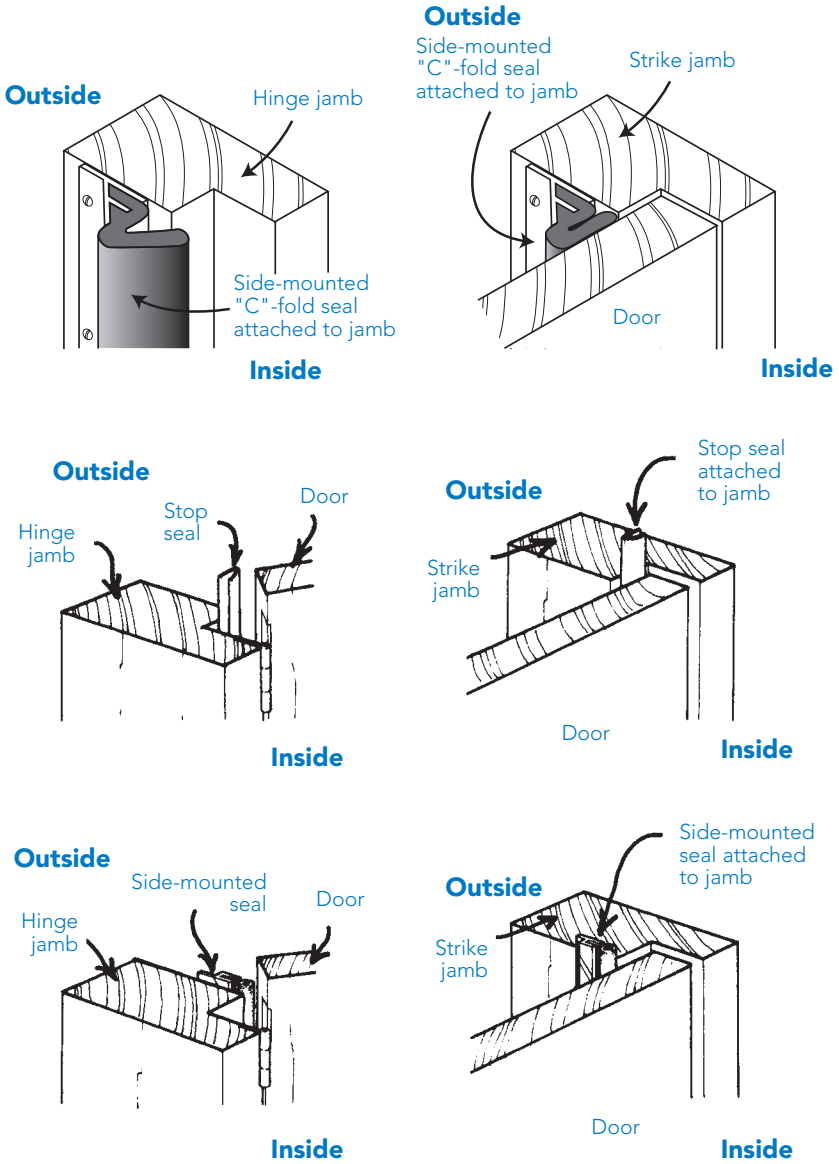

**Figure 14**

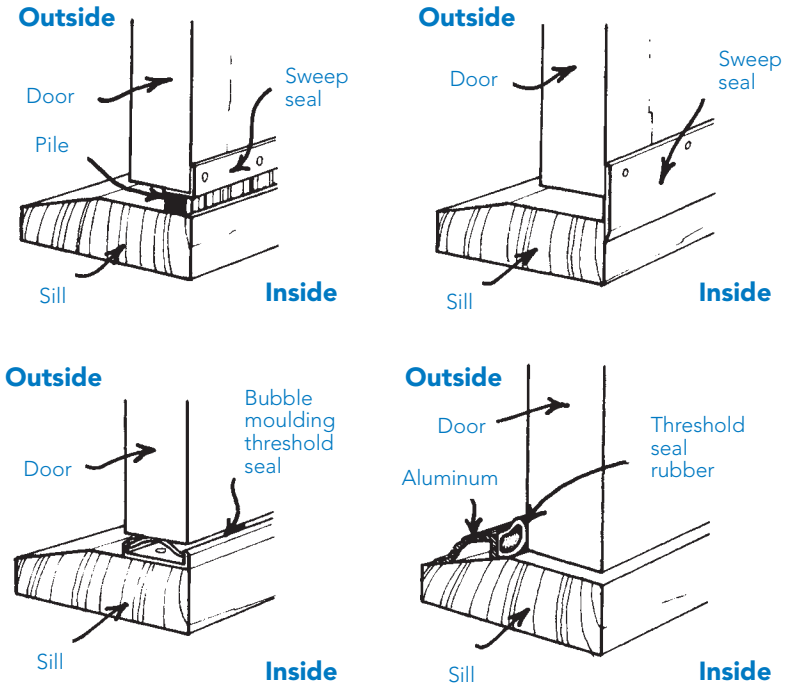

## Exterior walls

**Electrical switches and outlets** — Switch off the electricity and remove the cover plates from switches and outlets. Place a CSA-approved foam gasket on the receptacle, as shown in **Figure 15**. Reinstall the cover plate and insert childproof plugs in little-used outlets to further reduce air leakage.

**Junction of floor and exterior walls** — Run a continuous bead of clear or paintable sealant along the gap between the baseboard and wall, baseboard and base mould, and the base mould and floor, as shown in **Figure 16**.



**Figure 15**

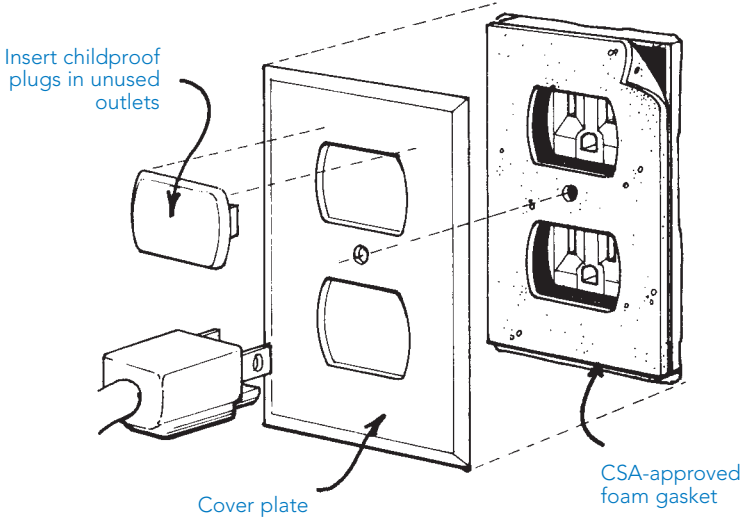

**Figure 16**

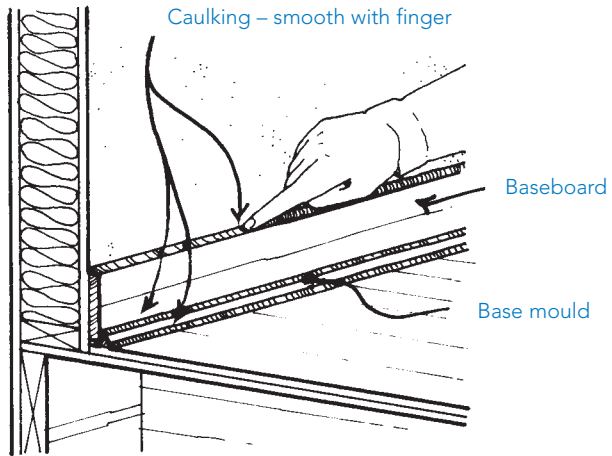

If exposed sealant along the baseboard is unacceptable, consider sealing *behind* the baseboard and base mould, as shown in **Figure 17**. Small gaps can be filled with caulking, while foam sealant will work better for larger gaps. Be careful to limit the amount of foam used, since it expands (trim the excess foam, if necessary).

**Cracks in the wall finish** — Use a sharp tool to open up the crack into a small ‘V’-shaped indentation. Fill and sand the crack using standard drywalling procedures.

**Figure 17**

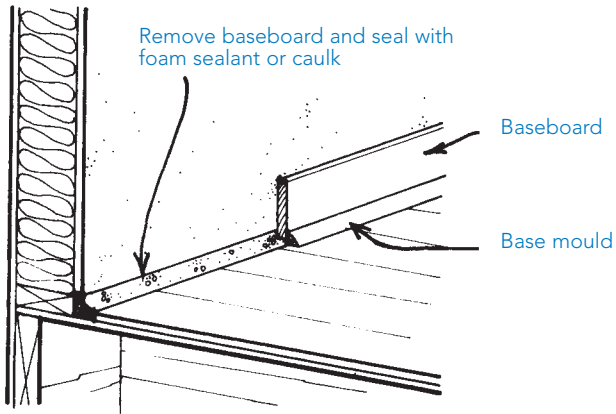

## Attics

**Attic hatches** — Weatherstrip the hatch as you would a door to the outside, as shown in **Figure 18**. Use latches to hold the hatch snugly against the weatherstripping. Seal around the ceiling trim of the hatchway.

**Plumbing stack** — This is difficult to seal because the stack can expand and contract as warm water flows through it. Use a flexible seal consisting of acoustical sealant, heavy polyethylene (0.15 mm - 6-mil), a hose clamp or zip ties on the pipe and staples or short screws at the ceiling, as shown in **Figure 19**.

**Figure 18**

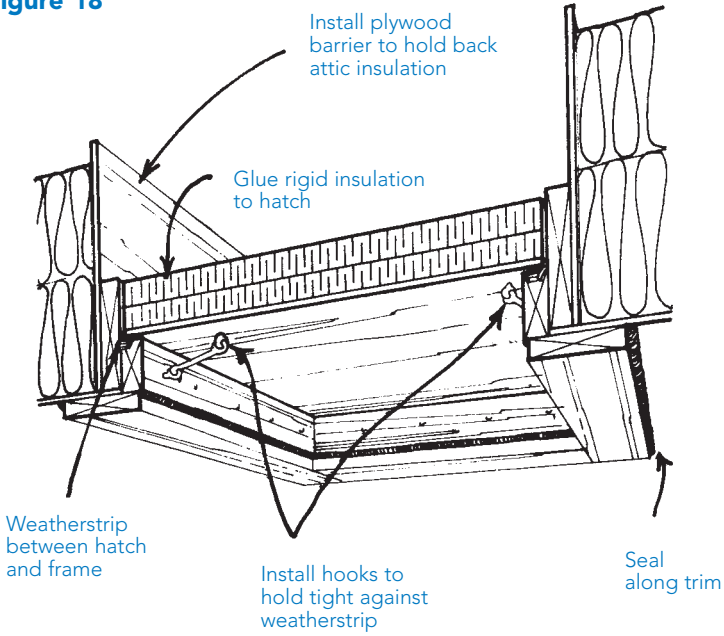

**Figure 19**

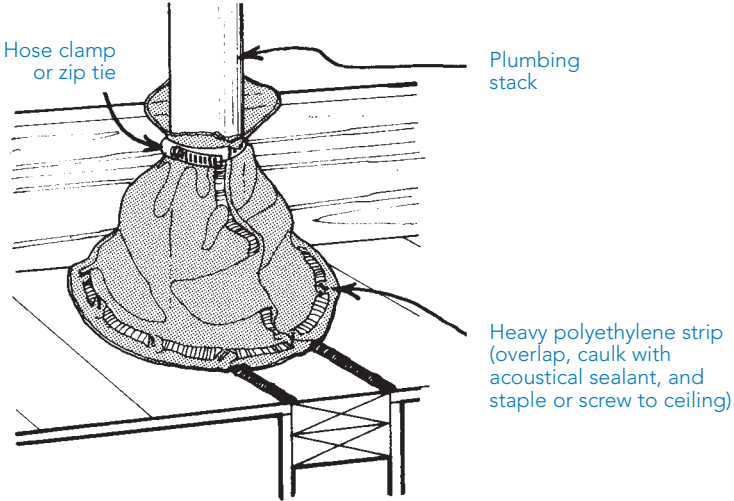

**Electrical wires and ceiling light fixtures** — Seal the space around electrical wires where they penetrate the attic space, as shown in **Figure 20**. Electrical boxes for ceiling light fixtures can be sealed with pieces of 0.15 mm (6-mil) polyethylene, acoustical sealant and staples, as shown in **Figure 20**. Alternatively, ceiling light fixtures can be sealed with caulking or CSA-approved foam gaskets from the interior, as shown in **Figure 21**.

**Recessed light fixtures** — It is often difficult to properly seal and insulate around recessed light fixtures. Unless the fixture is labelled Type IC (insulation contact), covering it with insulation or sealing it to reduce air leakage may create a fire hazard. Consider replacing recessed light fixtures with lights that hang down in the room below. If you want the recessed light to remain, install a protective enclosure as shown in **Figure 22**, or replace the fixture with an airtight Type IC unit.

**Figure 20**

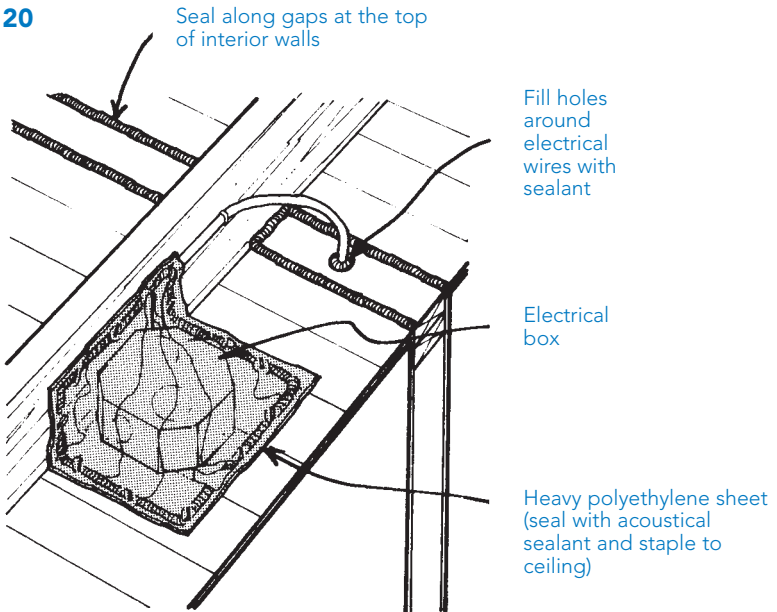

**Figure 21**

Seal with non-adhesive  
caulking or CSA-approved  
gasket

Ceiling light fixture

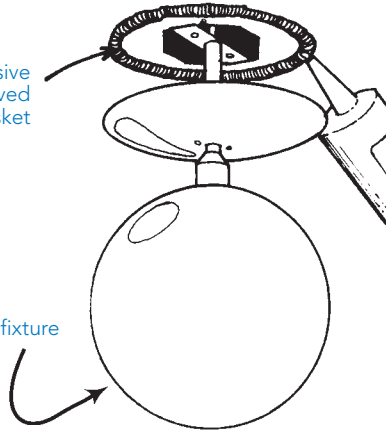

**Figure 22**

Minimum 12.5 mm (1/2 inch) clearance –  
150 mm (6 inches) preferred

Centre fixture if  
possible – keep it a  
minimum of 12.5 mm  
(1/2 inch) from sides

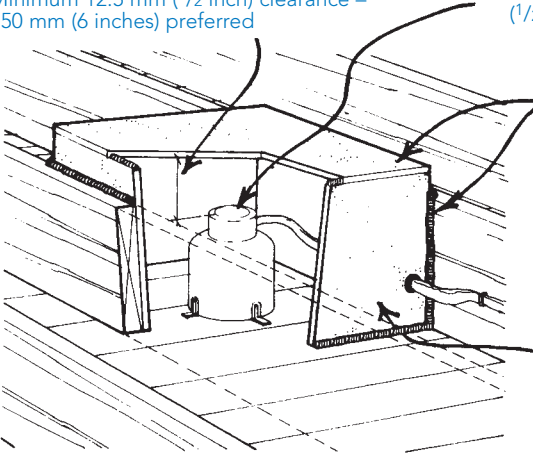

Cement board or 12.5 mm  
(1/2 inch) plywood box lined  
with fire resistant material  
such as drywall or sheet  
metal to provide airspace  
around fixture (seal all joints  
and edges of box to  
minimize air leakage)

Minimum box volume –  
allow 800 cubic centimetres  
per watt of fixture (e.g., a  
150-watt fixture would  
require a 120,000 cubic  
centimetre box)

**Exhaust fans and ducts** — Seal exhaust fans where they penetrate the attic, as illustrated in **Figure 23**. Joints in the ductwork should be sealed with foil tape. To prevent condensation within the ductwork and fan box, make sure they are wrapped with at least 100 mm (4 inches) of insulation.

**Junction of the ceiling and interior partitions** — Seal any gaps with caulking (see **Figure 20**).

**At the top of interior and exterior walls** — Wall cavities open to the attic represent gross air leakage and can be sealed by two methods.

1. Pack a short piece (150 mm) of batt insulation into the wall cavity, leaving it approximately 50-75 mm below the ceiling level. Spray foam on the batt, filling the cavity with a slight overlap onto the ceiling material (**Figure 24a**).
2. Run a bead of construction adhesive on either side of the opening and place wood, gypsum sheathing, or rigid insulation over the opening. Seal the edges of the sheathing to the ceiling and wood ceiling joists (**Figure 24b**).

**Chimneys** — Seal as shown in **Figures 25** and **26**. *Do not* use any material that is (or may become) flammable. Large gaps can be bridged by sheet metal. All joints should be sealed with a flexible, heat-resistant caulking or stove cement. Keep insulation at least 25 mm (1 inch) away from the chimney for natural gas or propane heating systems. For oil-fired heating systems, maintain a minimum gap of 50 mm (2 inches). Use a metal, cement board or gypsum drywall insulation stop that protrudes at least 75 mm (3 inches) above the upgraded insulation level.

For information on sealing around metal chimneys for wood burning fireplaces, stoves or furnaces, contact the chimney supplier or manufacturer. If this is not possible, contact Manitoba Labour at (204) 945-3322.

**Figure 23**

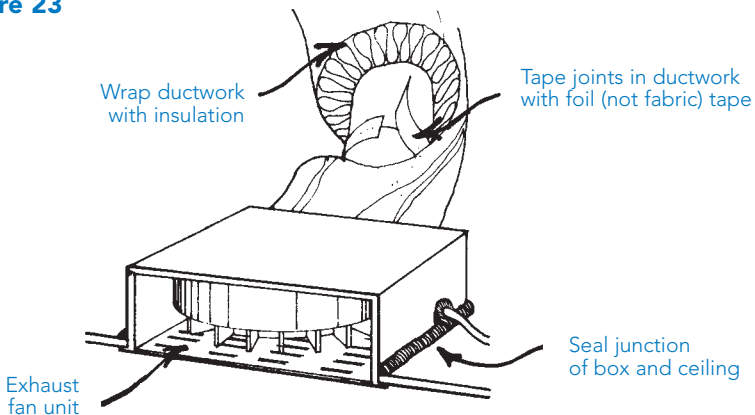

**Figure 24a**

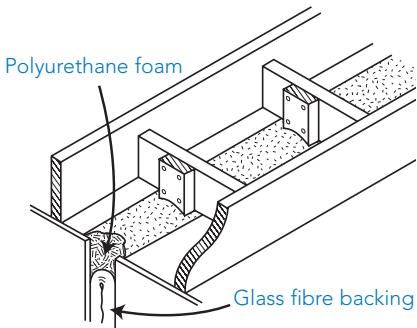

**Figure 24b**

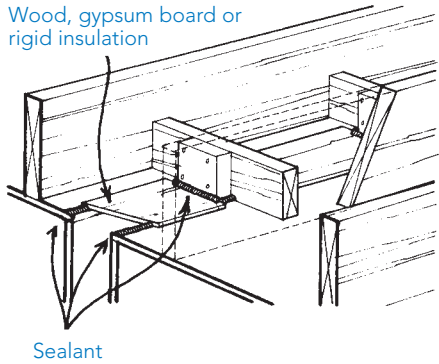

**Figure 25**

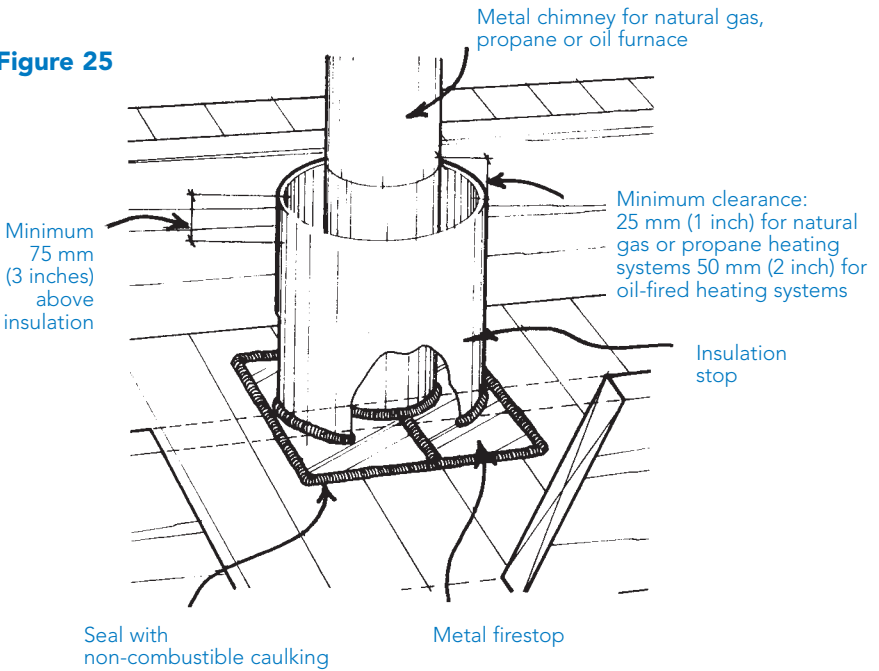

**Figure 26**

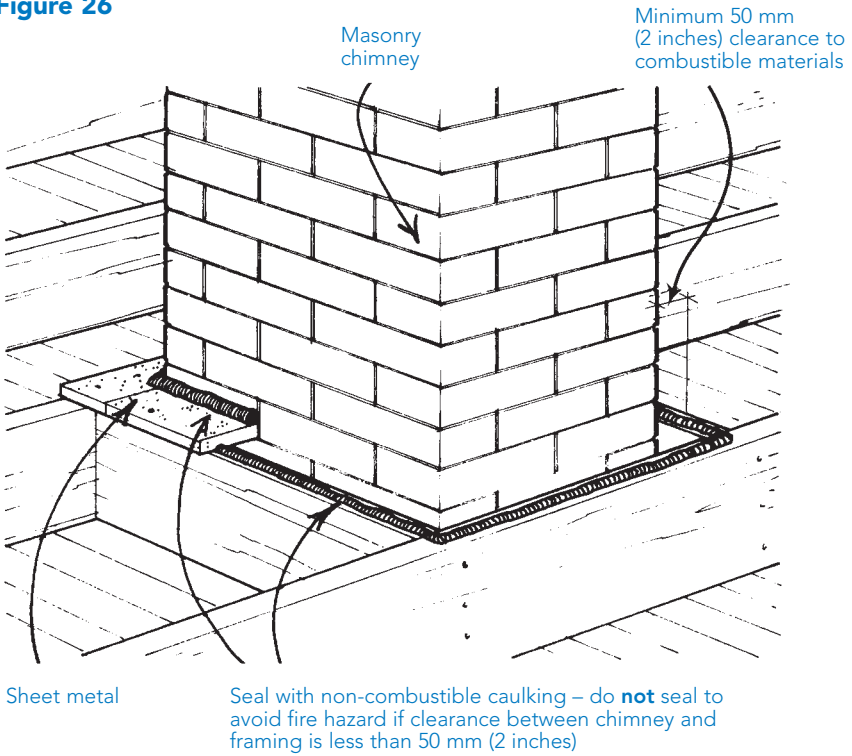

## Half-storey attics

Air sealing of half-storey attics is more complex than conventional attics, and is usually done in conjunction with insulation. Refer to Booklet #3: Attic insulation, for more details.

## Foundations

**Junction of the floor and foundation** — **Figure 27** shows how to seal typical air leakage paths for three common types of floor/foundation junctions. These techniques are for cases where the foundation walls are not insulated from the interior. For foundations that are to be insulated from the inside, refer to Booklet #2: Basement and crawl space insulation.

**Cracks in walls and floors** — Even though most of a foundation is surrounded by soil, cracks in foundation walls and floors can be a significant source of air leakage. This is because soil offers little resistance to air movement.



Small cracks can be sealed with polysulphide caulk or one-part polyurethane sealant. Cracks larger than 10 mm (3/8 inch) or cracks that are a source of water seepage require special sealing techniques — ask your local building material supplier for advice.

**Figure 27**

**A) Floor joists on sill plate**

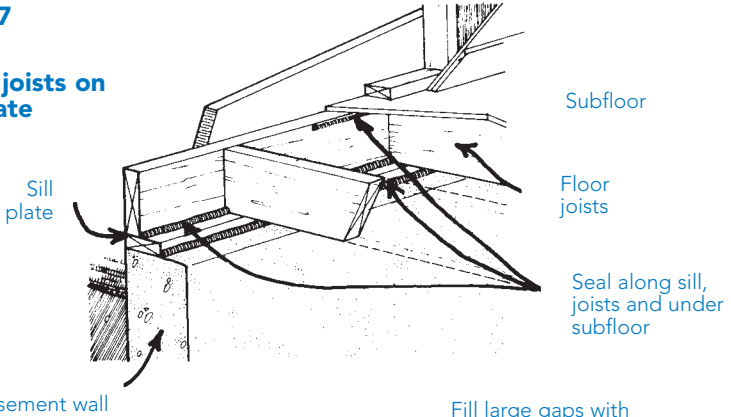

**B) Floor joists partially cast-in**

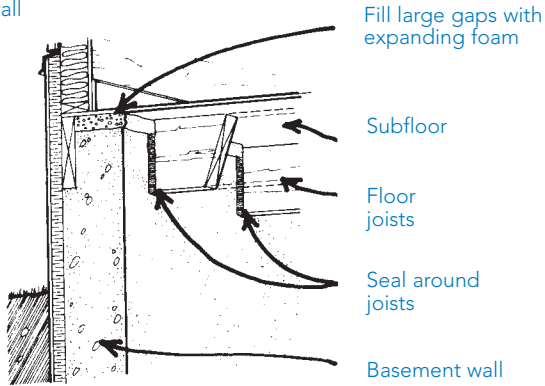

**C) Floor joists fully cast-in**

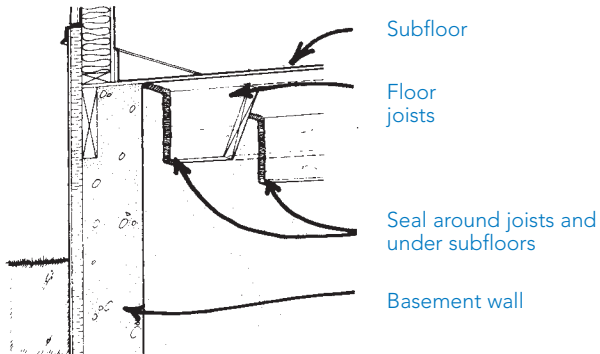

**Floor drain** — The floor drain in the basement floor slab is often a major source of air leakage if it is capped with a perforated cover. This air leakage can be greatly reduced by installing a solid floor drain cover equipped with a special trap. The trap will prevent air from leaking into the house yet will allow water to flow into the drain should the basement flood.

**Miscellaneous gaps and openings** — Be sure to seal gaps around wires, pipes, and ducts that penetrate the foundation. For hard-to-reach spots, plastic tubing can be used to extend the nozzle of a tube of caulk. If the gap is large, you may have to use backing (e.g. ethafoam rod, sponge rubber) for the caulking, as shown in **Figure 28**.

Expanding polyurethane foam may also be used to seal large gaps and cracks. Since this foam is flammable, and damaged by UV rays, it should be covered.

**Figure 28**

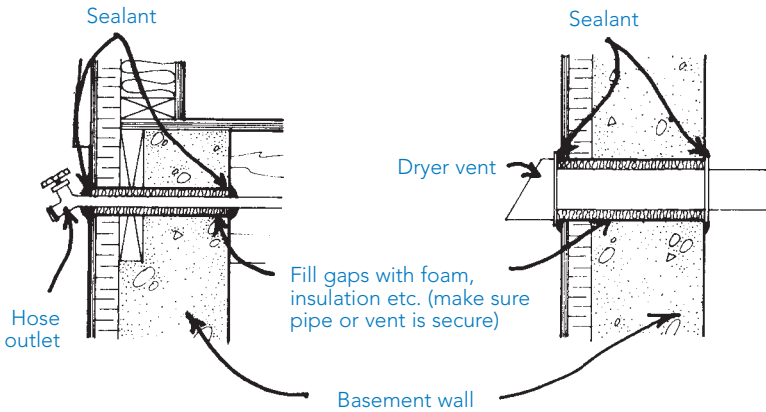











**Table 1**  
**Types of sealant**

Type	Durability	Paintable	Ease of application
<b>Acrylic latex</b>	Good	Yes	Very easy
<b>Butyl rubber</b>	Fair	Yes	Easy
<b>Silicone</b>	Excellent	See comments	Easy
<b>Acoustical sealant</b>	Excellent	No	Easy but messy
<b>Urethane foam sealant</b>	Good	See comments	Fair
<b>Polysulfide</b>	Excellent	No	Difficult



Relative cost	Comments
Moderate	<ul style="list-style-type: none"> <li>• bonds to most surfaces,</li> <li>• cures quickly,</li> <li>• cleans up with water.</li> </ul>
Moderate	<ul style="list-style-type: none"> <li>• bonds to most surfaces; is especially good on metal, masonry and concrete,</li> <li>• cures slowly,</li> <li>• shrinks noticeably while curing.</li> </ul>
High	<ul style="list-style-type: none"> <li>• bonds to most surfaces,</li> <li>• remains flexible; is good for joints with large movement,</li> <li>• may require a primer for wood, steel or treated aluminum surfaces,</li> <li>• most silicones cannot be painted.</li> </ul>
Low	<ul style="list-style-type: none"> <li>• excellent for joining polyethylene air-vapour barriers,</li> <li>• does not harden or form a skin; will collect dust and dirt if used on an exposed surface,</li> <li>• difficult to clean tools, hands, etc. after application.</li> </ul>
Moderate	<ul style="list-style-type: none"> <li>• bonds to most surfaces except polyethylene and some plastics,</li> <li>• available in small to large quantities,</li> <li>• excellent for filling large gaps that have little movement,</li> <li>• expands upon application,</li> <li>• has high insulation value,</li> <li>• some paints may dissolve foam — follow manufacturer's recommendations,</li> <li>• protect from ultra-violet rays.</li> </ul>
Moderate to high	<ul style="list-style-type: none"> <li>• needs primer to bond to surfaces; is especially good on stone, masonry and concrete surfaces,</li> <li>• remains flexible, is good for joints with large movement,</li> <li>• produces toxic fumes until cured; provide ventilation and use gloves when applying this sealant.</li> </ul>

**Table 2**  
**Weatherstripping materials**

Design	Type	Comments
<b>Tape</b>	Cloth or plastic	<ul style="list-style-type: none"> <li>• use on any non-opening window or door,</li> <li>• only good for one season,</li> <li>• quick and easy to install,</li> <li>• remains in full view,</li> <li>• may remove paint when peeled off,</li> <li>• low cost.</li> </ul>
<b>Gasket</b>	Felt	<ul style="list-style-type: none"> <li>• use on windows, doors and attic hatch for compression fits,</li> <li>• poor durability and air seal,</li> <li>• must be nailed, stapled or glued,</li> <li>• hidden from view,</li> <li>• made from wool, hair, cotton or polyester,</li> <li>• low cost.</li> </ul>
		
	Foam with adhesive backing	<ul style="list-style-type: none"> <li>• use on windows, doors and attic hatch for compression fits,</li> <li>• available in open- or closed- cell types,</li> <li>• closed cell is more durable,</li> <li>• poor to moderate durability and air seal,</li> <li>• quick and easy to install,</li> <li>• hidden from view,</li> <li>• low cost.</li> </ul>
		
	Foam on attachment strip	<ul style="list-style-type: none"> <li>• use on windows and doors for compression fit,</li> <li>• more durable than adhesive type,</li> <li>• poor to moderate durability and air seal,</li> <li>• must be nailed or screwed,</li> <li>• moderate cost.</li> </ul>
		
	Closed cell rubber with adhesive backing	<ul style="list-style-type: none"> <li>• use on windows and doors for compression fit,</li> <li>• good durability and air seal,</li> <li>• quick and easy to install,</li> <li>• hidden from view,</li> <li>• low to moderate cost.</li> </ul>
		



Design	Type	Comments
<b>Tubular</b>   	Core filled	<ul style="list-style-type: none"> <li>• use on windows and doors,</li> <li>• good durability and air seal,</li> <li>• must be nailed and stapled in full view,</li> <li>• made with rubber or plastic,</li> <li>• difficult to compress,</li> <li>• moderate to high cost.</li> </ul>
	Hollow	<ul style="list-style-type: none"> <li>• use on windows and doors,</li> <li>• good durability and air seal,</li> <li>• must be nailed or stapled in full view,</li> <li>• made with rubber or plastic,</li> <li>• moderate cost.</li> </ul>
	Hollow on attachment strip	<ul style="list-style-type: none"> <li>• use on windows and doors,</li> <li>• good durability and air seal,</li> <li>• usually nailed or screwed in full view,</li> <li>• slotted holes allow for re-adjustment,</li> <li>• made of rubber or plastic with aluminum or plastic attachment strips,</li> <li>• high cost.</li> </ul>
<b>Strip</b>  	Tension (spring metal or V-strip)	<ul style="list-style-type: none"> <li>• use on windows and doors; especially good for the gap where the sash of single hung windows meet,</li> <li>• excellent durability and good seal,</li> <li>• usually made of metal (bronze) or plastic,</li> <li>• must be nailed if metal, or attached with adhesive backing if plastic,</li> <li>• hidden from view,</li> <li>• moderate to high cost.</li> </ul>
	Fin or pile on attachment	<ul style="list-style-type: none"> <li>• use on windows and doors; especially good for sliding windows,</li> <li>• moderate to good seal and durability,</li> <li>• must be nailed or screwed in full view,</li> <li>• made with plastic, rubber or polyester pile with fin seal on wood, plastic or aluminum attachment strip,</li> <li>• moderate to high cost.</li> </ul>

Continued on next page

Design	Type	Comments
<b>Specialty</b> 	Spring loaded	<ul style="list-style-type: none"> <li>• use on windows and doors,</li> <li>• excellent durability and seal,</li> <li>• must be nailed or screwed in full view,</li> <li>• made with aluminum or plastic,</li> <li>• self-adjusting,</li> <li>• high cost.</li> </ul>
	Magnetic strip	<ul style="list-style-type: none"> <li>• use on windows and doors,</li> <li>• excellent durability and seal,</li> <li>• may make some doors difficult to open,</li> <li>• must be nailed or screwed in full view,</li> <li>• made with aluminum or plastic,</li> <li>• high cost.</li> </ul>
<b>Compression</b> 	Polyclad foam	<ul style="list-style-type: none"> <li>• use on door jambs,</li> <li>• excellent seal,</li> <li>• attached to carrier channel,</li> <li>• good range of movement,</li> <li>• suitable for most doors,</li> <li>• moderate cost.</li> </ul>

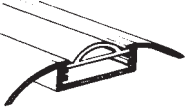

**Table 3**  
**Weatherstripping for door bottoms**

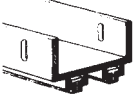
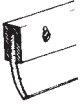
Type	Comments
<p><b>Saddle threshold</b></p> 	<ul style="list-style-type: none"> <li>• requires minimum clearance of 15 mm (<math>\frac{5}{8}</math> inch),</li> <li>• may have adjustable insert up to 30 mm (<math>1\frac{1}{4}</math> inch),</li> <li>• check that replacement gaskets are available,</li> <li>• good durability and seal,</li> <li>• made with plastic or rubber and an aluminum base,</li> <li>• installed with screws,</li> <li>• high cost.</li> </ul>
<p><b>Bumper threshold</b></p> 	<ul style="list-style-type: none"> <li>• bottom clearance not required,</li> <li>• can be damaged by trapped stones, etc.,</li> <li>• check that replacement gaskets are available,</li> <li>• good durability and seal,</li> <li>• made with plastic or rubber on a plastic, wood or aluminum attachment,</li> <li>• installed with screws on sill on exterior of door,</li> <li>• moderate cost.</li> </ul>
<p><b>Door bottom</b></p> 	<ul style="list-style-type: none"> <li>• requires minimum clearance of 8 to 13 mm (<math>\frac{1}{4}</math> to <math>\frac{1}{2}</math> inch),</li> <li>• some types can also be used as a saddle threshold,</li> <li>• check that replacement gaskets are available,</li> <li>• screwed into bottom; door must be removed for installation,</li> <li>• fair to good durability and seal, depending on material used,</li> <li>• made with rubber, metal, plastic or felt on an aluminum or plastic base,</li> <li>• moderate cost.</li> </ul>
<p><b>Door sweeps</b></p> 	<ul style="list-style-type: none"> <li>• good for uneven floors,</li> <li>• adjustable; some adjust automatically for sweeping over deep carpeting,</li> <li>• easy to attach; may be adhesive-backed, nailed or screwed,</li> <li>• attach to inside face on in-swinging door or outside of out-swinging door,</li> <li>• fair to good durability and seal, depending on material used,</li> <li>• made with plastic, rubber or polyester pile on an aluminum plastic or wood attachment strip,</li> <li>• low to moderate cost.</li> </ul>











For more information on Power Smart:

**Telephone: 204-480-5900 in Winnipeg**

**Toll-Free: 1 888 MBHYDRO (1-888-624-9376)**

Or visit [hydro.mb.ca](http://hydro.mb.ca)

## Publications in this series

- ① Sealing, caulking & weatherstripping
- ② Basement & crawlspace insulation
- ③ Attic insulation
- ④ Wall insulation
- ⑤ Doors & windows
- ⑥ Heating systems
- ⑦ Water heaters
- ⑧ Indoor air quality & ventilation
- ⑨ Energy saving tips



