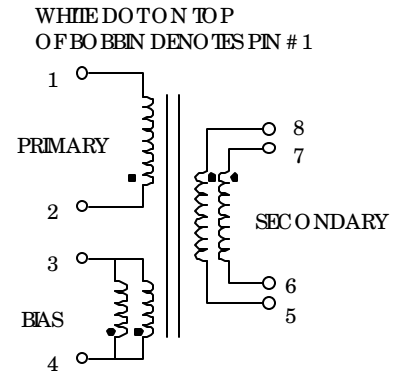

TABLE 1: ELECTRICAL SPECIFICATIONS AT 25 °C

SWITCHING TRANSFORMER DESIGNED FOR USE WITH POWER INTEGRATIONS TOP224P, (IS T1 ON RD5 DEMO BOARD). REFER TO APPLICATION CIRCUIT OF FIGURE 3.

PARAMETER	SPEC LIMITS			UNITS
	MIN.	TYP.	MAX.	
PRIMARY INDUCTANCE (2-1) VOLTAGE = 0.250Vrms FREQUENCY = 100 KHZ	585	650	715	μHY
TURN RATIO'S: SEC (8,7-6,5) : PRIMARY (2-1) BIAS (4-3) : PRIMARY (2-1)	-----	1: 8.375	-----	± 4%
PRI LEAKAGE IND. (SEC SHORTED) VOLTAGE = 0.250Vrms FREQUENCY = 100 KHZ	-----	-----	36.0	μHY
HIPOT: PRIMARY TO SECONDARY BIAS TO SECONDARY	3000 3000	----- -----	----- -----	Vrms Vrms
APP CIRCUIT PARAMETERS: (1) AC LINE VOLTAGE 47/400 Hz OUTPUT VOLTAGE OUTPUT CURRENT CONTINUOUS OUTPUT CURRENT PEAK LINE REGULATION (85 TO 265Vac) LOAD REGULATION 10-100% RIPPLE	85 ----- 0.0 ----- ----- ----- -----	----- 12.0 ----- ----- 0.20 0.20 50.0	265 ----- 1.70 2.00 ----- ----- -----	Vac Vdc Amps Amps ±% ±% ±mV

FIGURE 1: SCHEMATIC DIAGRAM



WHITE DOT ON TOP OF BOBBIN DENOTES PIN # 1
SEC ONDARY PINS # 8 & 7, # 6 & 5 MUST BE RESPECTIVELY CONNECTED TO EITHER FOR PROPER OPERATION. IE CONNECTED AS ONE PARALLEL WINDING.

NOTE1:
REINFORCED INSULATION SYSTEM, UL1950, IEC950, CSA-950:
A) ALL MATERIALS MEET "UL", "CSA" & "IEC" REQUIREMENTS
B) TRIPLE BASIC INSULATED SECONDARY.
C) DESIGNED TO MEET ≥6.2mm CREEPAGE REQUIREMENTS.
D) VARNISH FINISHED ASSEMBLY.
E) UL1950 & CSA-950 CERTIFIED: FILE #E162344.
F) UL CLASS (B) 130 INSULATION SYSTEM PM130-R1, PM130-H1, PM130-H1A (UL FILE #E177139) OR ANY UL AUTHORIZED CLASS (B) INSULATION SYSTEM.

(1) REFER TO RD5 APPLICATION CIRCUIT OF FIGURE 3.

FIGURE 2: PHYSICAL DIMENSIONS mm (INCHES)

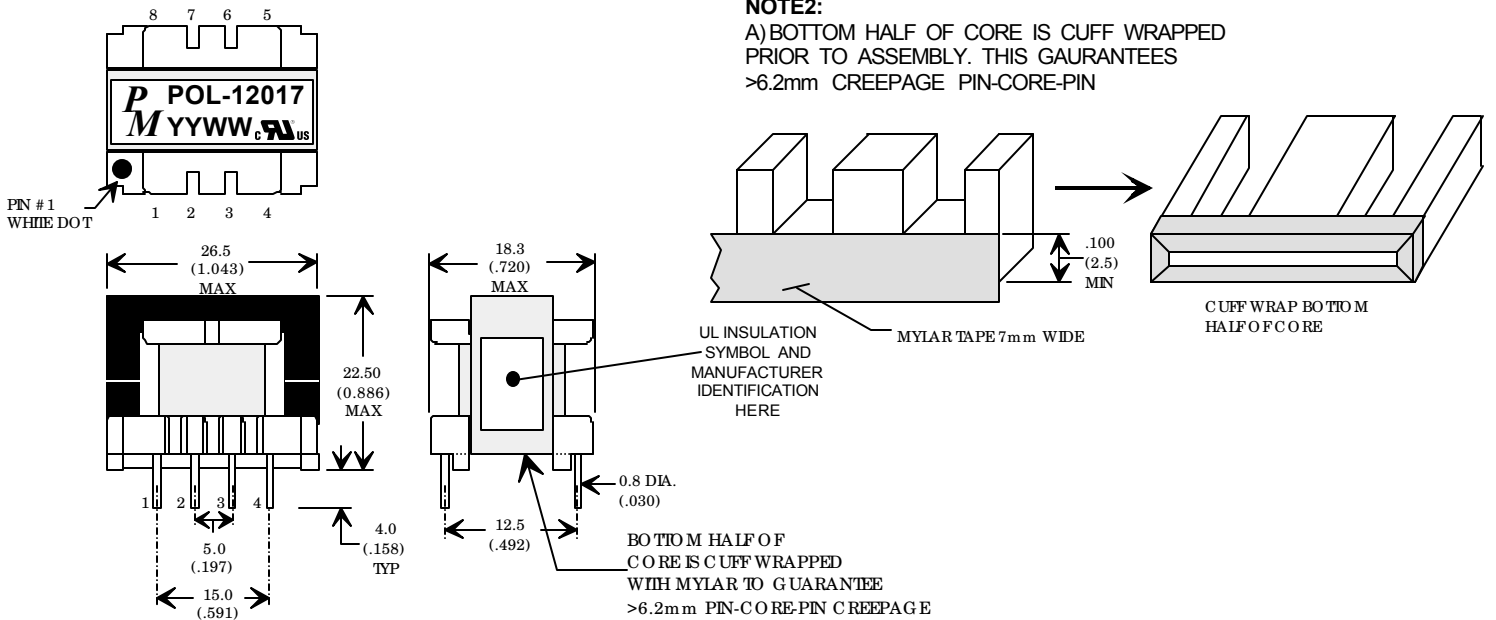

EE25.4 (FEI25, FEE25, EE2425), 8-PIN VERTICAL BOBBIN



UNLESS OTHERWISE SPECIFIED DIMENSIONS ARE IN MM
DIMENSIONAL TOLERANCES ARE:
DECIMALS ANGLES
.X ± .25 ±0° 30'
.XX ± .15
DO NOT SCALE DRAWING

REV.	DESCRIPTION OF CHANGES	BY
06/04/97	ORIGINAL RELEASE	TO
06/26/97	CORRECTED SCHEMATIC	TO
05/06/98	UPDATED RELEASE, CORRECTED MAX HEIGHT DIMENSION	TO
10/10/98	UPDATED TO ADD UL 1950 & CE-950 APPROVAL & MARKING	TO
05/06/99	UPDATE TO UL CLASS (B) 130 INSULATION SYSTEM	MD
01/18/00	CORRECT WIDTH DIMENSION TO 26.5mm MAX	PP
07/07/00	CHANGE SEC WDG TO 8-5& 7-6	PP

FLYBACK TRANSFORMER CONTROL DRAWING

PREMIER P/N: POL-12017	REVISION: 07/27/00
ENGR: TOM O'NEIL	REF: TOP224P, RD5
SCALE: NONE	SHEET: 1 OF 6

APPLICATION NOTES

Premier Magnetic's POL-12017 Switch Mode Transformer was designed for use with Power Integrations, Inc. PWR-TO224P three terminal off-line PWM switching regulator in the Flyback Buck-Boost circuit configuration. This conversion topology can provide isolated multiple outputs with efficiencies up to 90%. Premier's POL-12017 transformer has been optimized to provide maximum power throughput.

The TOPSwitch-II series from Power Integrations, Inc. are self contained 100KHz three terminal voltage controlled PWM switching regulators. This series contains all necessary functions for an off-line switched mode control DC power source. These switching regulators provide a very simple solution to off-line designs. The inductors and transformer used with the TOPXXX are critical to the performance of the circuit. They define the overall efficiency, output power and overall physical size.

Below is a universal input high precision 20 watt application circuit utilizing Power Integrations TO224 switching regulator in the flyback buck-boost configuration. The component values listed are intended for reference purposes only. Please refer to Power Integrations application notes for the RD5 demo board for more information.

FIGURE 3: TYPICAL APPLICATION CIRCUIT

