



Metric/BSP Fittings and Conversion Adapters



The Fitting Authority

Metric/BSP Fittings and Conversion Adapters

Introduction

Parker makes tube fittings and conversion adapters for connecting to all major ports used worldwide. These include:

Port name	Port standard	Thread standard and type
Metric straight thread, O-ring	ISO 6149-1	ISO 261
Metric parallel thread, flat face	ISO 9974-1/DIN 3852, part 1	ISO 261
BSPP, flat face	ISO 1179-1/DIN 3852, part 2	ISO 228-1, "G" – British Standard Pipe, Parallel
JIS/BSPP parallel pipe thread, O-ring	JIS B2351, Type "O"	ISO 228-1/JIS B0202, "G"
BSPT	—	ISO 7-1/JIS B0203, "Rc" British Standard Pipe, Taper
NPTF	SAE J476	SAE J476, Dryseal (taper) pipe
SAE straight thread, O-ring	SAE J1926-1/ISO 11926-1	ANSI B1.1, UN/UNF



Traditionally, Parker fittings have been grouped by the type of tube or hose connection end such as Seal-Lok™, Triple-Lok®, Ferulok®, etc. This arrangement serves the majority of the market that uses SAE straight thread O-ring and NPTF pipe ports very well. However, as more and more equipment using ports other than SAE and NPTF is imported/manufactured in the USA, there is a growing need by users trying to service the equipment to see all connectors with a given port end connection in one catalog location.



This section is, therefore, arranged by the type of port connection end. All fittings and conversion adapters offered by Parker, regardless of the tube or hose connection end type, are grouped together so the user can view them all in one location rather than having to search through several sections. Thus, the visual index and the body of this section of the catalog show

groups of fittings and conversion adapters, each connecting to a given port from the list above.

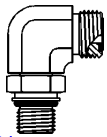
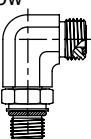
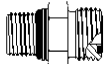
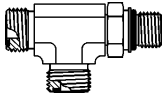
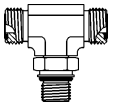
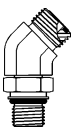
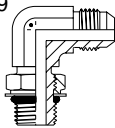
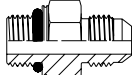
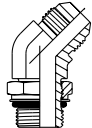
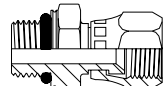
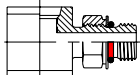
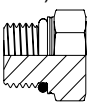
The visual index sections for Seal-Lok, Triple-Lok and Pipe fittings also show these connectors with non-traditional port ends, with references to pages in this section. Thus, if a user is searching in the visual index of Seal-Lok, Triple-Lok or Pipe section for connectors with Metric or BSP port connection end, he or she is directed to this section. In such, the general technical information for each of these is also contained in this section as follows: Metric Seal-Lok [pages I9 to I20](#), Metric Triple-Lok [pages I41 to I44](#), and Pipe Conversion Adapters [pages I65 to I72](#).

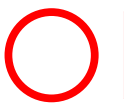
We hope this arrangement makes searching for the right fitting or adapter easier.

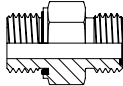
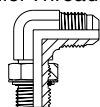
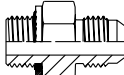
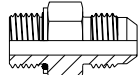
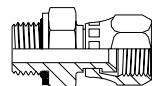

<h2 style="text-align: center;">Fittings and Conversion Adapters for Connecting to or with ISO 6149-1 Port</h2>					
Seal-Lok Tube to ISO 6149	C87OMLO Metric Straight Thread Elbow  Page I21	CC87OMLO Long Metric Straight Thread Elbow  Page I22	F87OMLO Metric Straight Thread Connector  Page I23	R87OMLO Metric Straight Thread Run Tee  Page I24	S87OMLO Metric Straight Thread Branch Tee  Page I24
V87OMLO Metric Straight Thread 45° Elbow  Page I25	Triple-Lok Tube to ISO 6149	C87OMX Male Elbow ISO 6149  Page I60	F87OMX Male Connector ISO 6149  Page I58	V87OMX Male 45° Elbow ISO 6149  Page I60	F687OMX 37° Swivel to ISO 6149  Page I51
24° Cone Metric to ISO 6149	See Section H for 24° Cone EO and EO-2 Fittings	ISO 6149 Conversion Adapters	A87LPOEG87LP Male ISO 6149 Female ISO 6149  Page I79		
ISO 6149 Plugs & O-Rings	P87OMN Hex Head Plug (ISO 6149)  Page I80	VSTI-M-OR Hollow Hex Plug (ISO 6149)  Page I81	ISO 6149 Metric Straight Thread Port O-ring  Page I35		

<h2 style="text-align: center;">Fittings and Conversion Adapters for Connecting to or with Metric Flat Face Port — ISO 9974-1/DIN 3852 Type 1</h2>					
Seal-Lok to Metric Stud End (DIN 3852)	F82EDMLO Male Straight Connector - Metric Parallel Thread  Page I40	Triple-Lok to Metric Stud End (DIN 3852)	C80MX Male Elbow - Metric Parallel Thread  Page I59	F80MX Male Straight Connector - Metric Parallel Thread  Page I56	F82EDMX Male Straight Connector - Metric Parallel Thread  Page I57
F680MX 37° Swivel to Male Metric Parallel Thread  Page I51	24° Cone Metric to Metric Stud End (DIN 3852)	See Section H for 24° Cone EO and EO-2 Fittings	Plugs & Seals Metric (DIN 3852)	VSTI-M-ED Hollow Hex Plug (Metric DIN 3852)  Page I80	ED EOlastic Soft Seal for BSPP & Metric Threads  Page H123

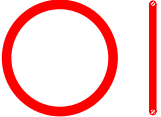
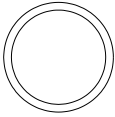
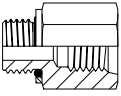
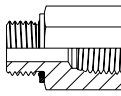



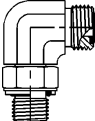
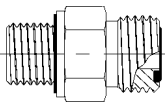
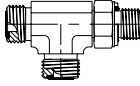
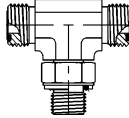
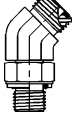
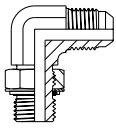
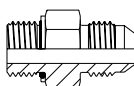
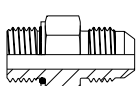
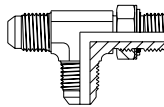
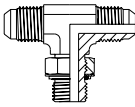
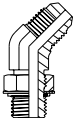
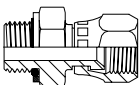
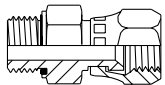
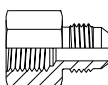
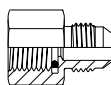
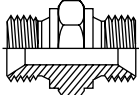
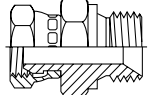
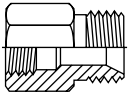
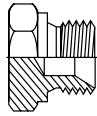
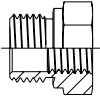

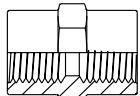
Fittings and Conversion Adapters for Connecting to or with Metric Flat Face Port — ISO 9974-1/DIN 3852 Type 1 (cont'd.)

<p>Metric O-Ring</p>  <p>Page I64</p>	<p>RR Metric Retaining Ring</p>  <p>Page I64</p>	<div style="background-color: black; color: red; padding: 5px; text-align: center;"> Conversion Adapters Metric (DIN 3852) </div>	<p>F8OHG5 Male Metric/ Female SAE</p>  <p>Page I75</p>	<p>F8OHG Male Metric/ Female NPT</p>  <p>Page I75</p>	
--	---	--	---	--	--

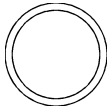

Fittings and Conversion Adapters for Connecting to or with BSPP Port — ISO 1179-1/DIN 3852 Type 2

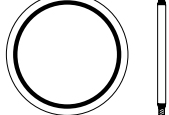
<div style="background-color: black; color: red; padding: 5px; text-align: center;"> Seal-Lok to BSPP Stud End (DIN 3852) </div>	<p>C4OMLO BSPP Elbow</p>  <p>Page I37</p>	<p>F42EDMLO BSPP Connector</p>  <p>Page I38</p>	<p>R4OMLO BSPP Run Tee</p>  <p>Page I39</p>	<p>S4OMLO BSPP Branch Tee</p>  <p>Page I39</p>	<p>V4OMLO BSPP 45° Elbow</p>  <p>Page I40</p>
<div style="background-color: black; color: red; padding: 5px; text-align: center;"> Triple-Lok to BSPP Stud End (DIN 3852) </div>	<p>C4OMX Male Elbow BSPP</p>  <p>Page I48</p>	<p>F4OMX Male Straight Connector BSPP</p>  <p>Page I52</p>	<p>F42EDMX Male Straight Connector BSPP</p>  <p>Page I53</p>	<p>R4OMX Male Run Tee BSPP</p>  <p>Page I55</p>	<p>S4OMX Male Branch Tee BSPP</p>  <p>Page I54</p>
<p>V4OMX Male 45° Elbow BSPP</p>  <p>Page I54</p>	<p>F64OMX 37° Swivel to Male BSPP</p>  <p>Page I50</p>	<p>F642EDMX 37° Swivel to Male BSPP</p>  <p>Page I50</p>	<div style="background-color: black; color: red; padding: 5px; text-align: center;"> Triple-Lok to Female BSPP (DIN 3852) </div>	<p>G4MX Female Connector BSPP</p>  <p>Page I55</p>	<p>G4MXMO Manometer Connection BSPP</p>  <p>Page I49</p>
<div style="background-color: black; color: red; padding: 5px; text-align: center;"> BSPP 60° Cone to BSPP </div>	<p>HMK4 Straight Union Connector</p>  <p>Page G20</p>	<p>F6MK4 Straight Swivel Nut Connector</p>  <p>Page G24</p>	<p>G4MK4 BSPP Female Straight Connector</p>  <p>Page G19</p>	<p>PNMK4 60° Cone Plug</p>  <p>Page G22</p>	
<div style="background-color: black; color: red; padding: 5px; text-align: center;"> 24° Cone Metric to BSPP </div>	<p style="text-align: center; color: blue;">See Section H for 24° Cone EO and EO-2 Fittings</p>	<div style="background-color: black; color: red; padding: 5px; text-align: center;"> Reducer/ Expander & Coupling BSPP (DIN 3852) </div>	<p>RI BSPP Reducing Adapters/Expander</p>  <p>Page I84</p>	<p>RI-ED BSPP Reducing Adapter/Expander</p>  <p>Page I83</p>	<p>GG44M BSPP Pipe Coupling</p>  <p>Page I82</p>

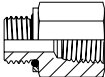
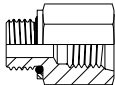
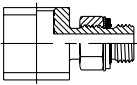

Fittings and Conversion Adapters for Connecting to or with BSPP Port — ISO 1179-1/DIN 3852 Type 2 (cont'd.)

 <p>Plugs & Seals BSPP (DIN 3852)</p>	<p>VSTI-R-ED Hollow Hex Plug (BSPP DIN 3852)</p>  <p>Page I81</p>	<p>ED Elastic Soft Seal for BSPP & Metric Stud Ends</p>  <p>Page H123</p>	<p>BSPP BSPP Retaining Ring</p>  <p>Page I63</p>	<p>BSPP BSPP O-Ring</p>  <p>Page I63</p>	<p>D9DT BSPP Bonded Seal</p>  <p>Page G25</p>
	 <p>Conversion Adapters BSPP (DIN 3852)</p>	<p>F40HG Male BSPP/ Female NPT</p>  <p>Page I74</p>	<p>F40HG5 Male BSPP/ Female SAE</p>  <p>Page I74</p>	<p>A40EG4M Male BSPP/ Female BSPP</p>  <p>Page I79</p>	

Fittings and Conversion Adapters for Connecting to or with JIS B2351 Type “O” Port

 <p>Plug & O-Rings (JIS B2351)</p>	<p>P47OMN Hex Head Plug for JIS B2351</p>  <p>Page G12</p>	<p>P O-Ring JIS B2351 O-Ring</p>  <p>Page G13</p>			

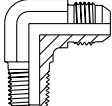
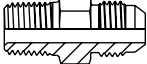
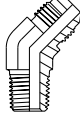
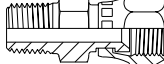
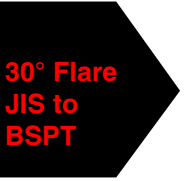
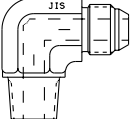
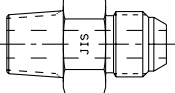
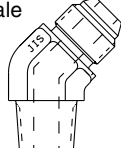
Fittings and Conversion Adapters for Connecting to or with BSPT/BSPP Ports

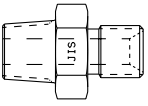
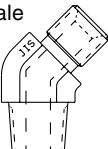
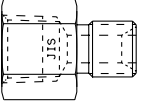
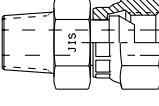
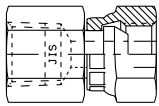

 <p>Triple-Lok to Male BSPT</p>	<p>C3MX Male Elbow BSPT</p>  <p>Page I45</p>	<p>F3MX Male Straight Connector BSPT</p>  <p>Page I46</p>	<p>V3MX Male 45° Elbow BSPT</p>  <p>Page I47</p>	<p>F63MX 37° Swivel to Male BSPT</p>  <p>Page I49</p>	
	 <p>30° Flare JIS to BSPT</p>	<p>C3T4 Male Elbow</p>  <p>Page G7</p>	<p>F3T4 Male Connector</p>  <p>Page G7</p>	<p>V3T4 45° Male Elbow</p>  <p>Page G8</p>	 <p>60° Cone JIS to BSPT</p>
<p>F3P4 Male Connector</p>  <p>Page G8</p>	<p>V3P4 45° Male Elbow</p>  <p>Page G9</p>	<p>G3P4 Female Connector</p>  <p>Page G11</p>	<p>F63P4 Swivel Connector</p>  <p>Page G10</p>	<p>G63P4 Swivel Connector</p>  <p>Page G10</p>	

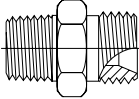
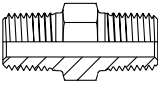
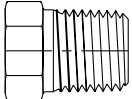
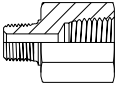
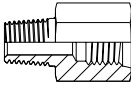

Fittings and Conversion Adapters for Connecting to or with BSPT/BSPP Ports (cont'd.)

BSPP 60° Cone to BSPT	<p>F3MK4 BSPT Male Straight Connector</p>  <p>Page G18</p>	Pipe Nipple BSPT	<p>FF33M BSPT Pipe Nipple</p>  <p>Page I82</p>	Plug BSPT	<p>HP3M BSPT Hex Head Pipe Plug</p>  <p>Page I85</p>
Conversion Adapters	<p>F3HG Male BSPT/ Female NPT</p>  <p>Page I73</p>	<p>F3HG5 Male BSPT/ Female SAE</p>  <p>Page I73</p>			

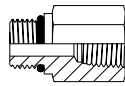

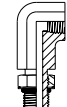
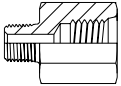
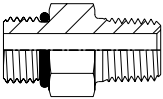



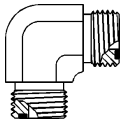
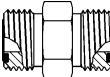
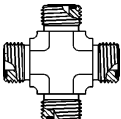
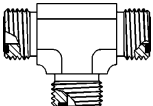



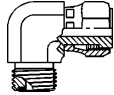
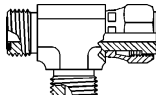
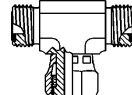

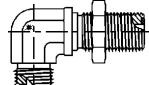
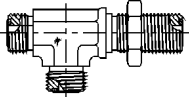
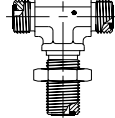
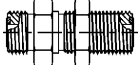
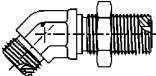





Conversion Adapters for Connecting to or with SAE Straight Thread O-Ring Ports and NPTF Ports

SAE to NPTF	<p>F50G Male SAE/ Female NPTF</p>  <p>Page I78</p>	<p>AOEG Male SAE/ Female NPTF</p>  <p>Page I76</p>	<p>AOE4G Male SAE/Female NPTF - Long Elbow</p>  <p>Page I77</p>	NPTF to SAE	<p>FHG5 Male NPTF/ Female SAE</p>  <p>Page I76</p>
Nipple SAE to NPTF	<p>F50F Male SAE/ Male NPTF</p>  <p>Page I77</p>				

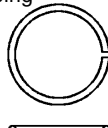
Unions, Swivels, Bulkheads and Components with Metric Wrench Flats and Sleeves for Metric Tubing

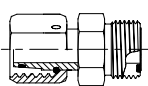

Seal-Lok Tube to Tube	<p>EMLO Union Elbow</p>  <p>Page I27</p>	<p>HML0 Union Straight</p>  <p>Page I27</p>	<p>KMLO Union Cross</p>  <p>Page I28</p>	<p>JMLO Union Tee</p>  <p>Page I28</p>	
------------------------------	--	---	--	--	--

Unions, Swivels, Bulkheads and Components with Metric Wrench Flats and Sleeves for Metric Tubing (cont'd.)

<p>Tube to Seal-Lok Swivel</p> 	<p>C6MLO Swivel Nut Elbow</p>  <p>Page I25</p>	<p>R6MLO Swivel Nut Run Tee</p>  <p>Page I26</p>	<p>S6MLO Swivel Nut Branch Tee</p>  <p>Page I26</p>	<p>Seal-Lok Bulkhead Unions</p> 	<p>WEMLO Bulkhead Union Elbow</p>  <p>Page I29</p>
<p>WJMJLO Bulkhead Run Tee</p>  <p>Page I29</p>	<p>WJMLO Bulkhead Branch Tee</p>  <p>Page I31</p>	<p>WMLO Bulkhead Union</p>  <p>Page I30</p>	<p>WNMLO 45° Bulkhead Union Elbow</p>  <p>Page I30</p>	<p>Seal-Lok Braze Connector</p> 	<p>MMLOHB3 Braze Connector Straight</p>  <p>Page I32</p>
<p>Seal-Lok Auxiliary Components</p> 	<p>BML Tube Nut</p>  <p>Page I31</p>	<p>PNMLO Plug</p>  <p>Page I32</p>	<p>TL Braze Sleeve For Metric Tubing</p>  <p>Page I33</p>	<p>TPL Parflange Sleeve For Metric Tubing</p>  <p>Page I33</p>	<p>WLNML Bulkhead Locknut</p>  <p>Page I34</p>
<p>Face Seal O-Ring ORFS Tube End</p>  <p>Page I34</p>	<p>SBR Silver Braze Ring for Metric Tubing</p>  <p>Page I36</p>	<p>Conversion Adapter EO to Seal-Lok</p> 	<p>LOHU86 EO Swivel Adapter</p>  <p>Page B38</p>		
<p>Triple-Lok Auxiliary Components</p> 	<p>BTX Nut</p>  <p>Page I62</p>	<p>TX Sleeve for Metric Tubing</p>  <p>Page I61</p>			

I

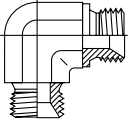
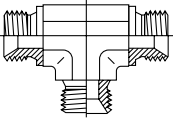
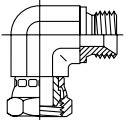
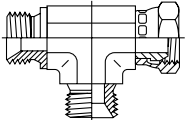
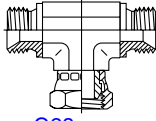
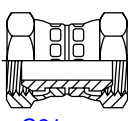
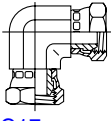
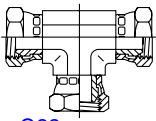
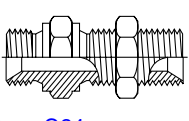
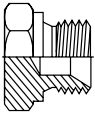
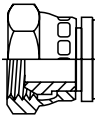
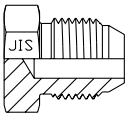
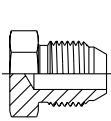
Unions, Swivels, Bulkheads and Components with BSP Threads, but with *Inch* Hex Flats

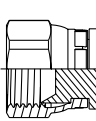
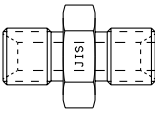
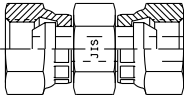
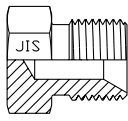
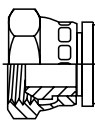
<p>60° Cone BSPP Unions</p>	<p>EMK4 Elbow Union</p>  <p>Page G16</p>	<p>JMK4 Union Tee</p>  <p>Page G21</p>	<p>60° Cone BSPP Swivels</p>	<p>C6MK4 Swivle Nut Elbow</p>  <p>Page G16</p>	<p>R6MK4 Swivel Nut Run Tee</p>  <p>Page G23</p>
<p>S6MK4 Swivel Nut Branch Tee</p>  <p>Page G23</p>	<p>H6MK4 Swivel Nut Striaight Union Connector</p>  <p>Page G21</p>	<p>E6MK4 90° Swivel Nut Elbow Union</p>  <p>Page G17</p>	<p>J6MK4 Swivel Nut Union Tee</p>  <p>Page G22</p>	<p>60° Cone BSPP Bulkhead</p>	<p>WMK4WL4NM Straight Bulkhead Union</p>  <p>Page G24</p>
<p>60° Cone BSPP Plugs and Caps</p>	<p>PNMK4 60° Cone Plug</p>  <p>Page G22</p>	<p>FNMK4 Cap for 60° Cone</p>  <p>Page G18</p>			
<p>30° Flare JIS Plugs and Caps</p>	<p>PNMT4 Plug with 30° Flare</p>  <p>Page G13</p>	<p>PNMKA Komatsu 30° Flare Plug</p>  <p>Page G15</p>	<p>FNMT4 Cap for 30° Flare</p>  <p>Page G14</p>	<p>FNMKA Komatsu 30° Flare Cap</p>  <p>Page G15</p>	
<p>60° Cone JIS Union</p>	<p>HP4 Union</p>  <p>Page G12</p>	<p>60° Cone JIS Swivel</p>	<p>HP46 Swivel Union Connector</p>  <p>Page G11</p>		
<p>60° Cone JIS Plugs and Caps</p>	<p>PNMP4 Plug with 60° Cone</p>  <p>Page G14</p>	<p>FNMK4 Cap for 60° Cone</p>  <p>Page G18</p>			

Metric Seal-Lok Fittings

The Seal-Lok fitting was developed by Parker Tube Fittings Division in the early 1980s. This product line has proven to be very effective in eliminating leakage at the higher pressures found in today's hydraulic systems. Metric Seal-Lok conforms to International Standards Organization (ISO) 8434-3 and SAE J1453 standards. As shown in Fig. 11, it consists of:

- **Tube/hose connection** - The leak free face seal concept, with inch threads, per SAE J1453.
- **Port side connection** - The proven straight thread O-ring port concept, with metric threads per ISO 6149-2 and SAE J2244/2.
- **Metric wrench flats** - metric hex and across forging flats.

The proven leak-free face seal connection along with the metric hexes and forging flats and the ISO 6149-2 port end make this fitting an ideal choice for worldwide acceptability. With this as a goal, the U. S. delegation to ISO TC131/SC4/WG6 proposed the above design and championed its approval at ISO (International Standards Organization). It is now published as ISO 8434-3.

Design & Construction

The tube/hose connection is the same as standard (inch) Seal-Lok. It consists of a body, a flange or braze sleeve, an O-ring and a nut. The difference is at the port end of the fitting. Instead of the SAE straight thread connection, it features similar connection with metric threads per ISO 6149-2.

Identification

To differentiate metric Seal-Lok from standard (inch) Seal-Lok, the following identification features have been incorporated in the design:

- Straight connectors (straight studs) have a short length of turn diameter with a small groove machined in it's middle, as seen in Fig. 12.
- The lock nut on shaped connectors (stud elbows, tees and crosses) have a similar turn diameter adjacent to the washer, without a groove, as seen in Fig. 13.

Metric Seal-Lok Body

Metric Seal-Lok is available in several different shapes and straights to accommodate virtually any application. The O-ring face seal end of the body features a precision machined half dovetail Captive O-Ring Groove (CORG) which holds a high durometer O-ring for sealing.

The straight bodies are made from cold drawn bar stock. The cold drawing process increases strength and improves the surface finish and dimensional consistency. The shapes are forged for one piece (joint-less) construction. The forgings are heat treated for an optimum combination of strength and machinability. Besides improved strength, the forgings also provide longer service life through optimum grain flow.

Metric Seal-Lok Flange Sleeve

The preferred method of making a Seal-Lok connection is by using the Parker Parflange machine (Figure 17) to create the 90° flange on the tube end. A flange sleeve, similar to a braze sleeve, is used to support the flange and the tube.

The flange sleeve is of the same design for metric and standard inch Seal-Lok. It provides the contact shoulder for the nut, a back-up for the 90° tube flange and support at the tube O.D.

The Seal-Lok connection using the Parflange method can be made with either inch or metric tubing by choosing the appropriate sleeve and tooling. The sleeve for metric tubing is identified by a small groove machined on the large diameter of the sleeve as shown in Fig. 14.

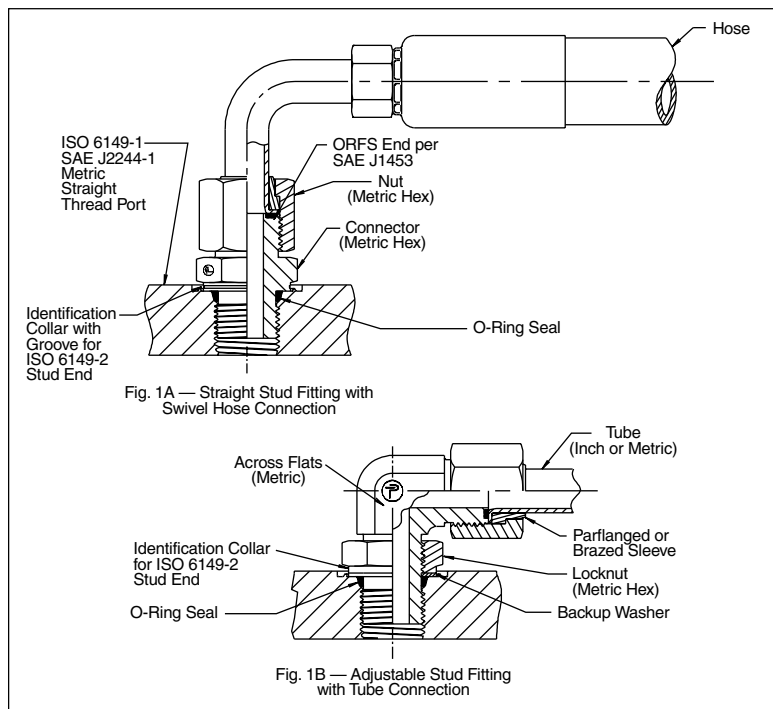

Fig. 11 — Metric Seal-Lok Fitting Conforming To ISO 8434-3 and SAE J1453.

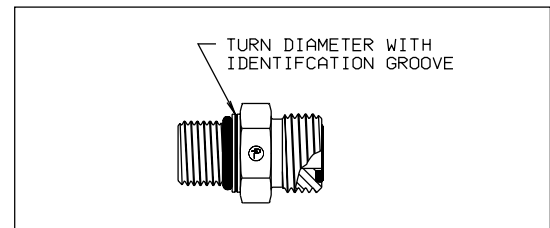

Fig. 12 — Metric Seal-Lok Straight Stud Fitting

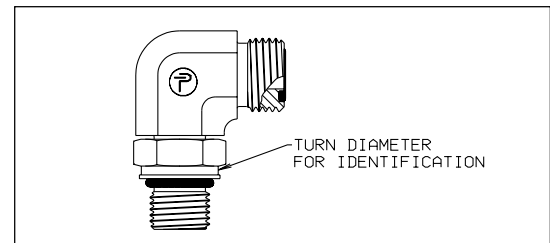

Fig. 13 — Metric Seal-Lok Elbow Stud Fitting



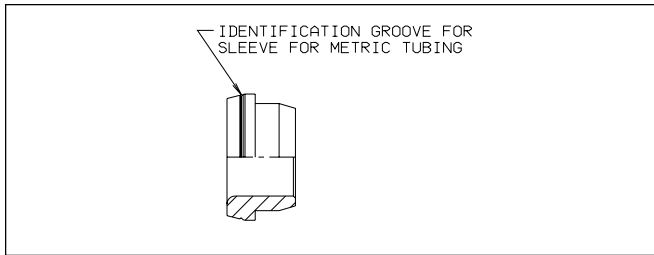

Fig. 14 — Parflange Sleeve for Metric Tubing

The main difference between braze and flange sleeves is the method of attachment to the tube (see Fig. 16). The braze sleeve, as the name implies, is attached to the tube through brazing. The braze provides holding power as well as a method to seal the joint.

With the flange sleeve, the tube to sleeve attachment is done mechanically by creating a 90° flange in front of the sleeve with the Parflange machine. This flange provides both the holding power and sealing surface, eliminating the braze joint, which is considered a potential leak path. The only seal point is now between the fitting body and the tube flange face via the high durometer O-ring.

Besides eliminating a joint, the flanging process is fast and requires very little cleaning prior to or after flanging. Thus, the process enhances the integrity of the joint and reduces cost.

Metric Seal-Lok Braze Sleeve

The Seal-Lok connection can be made with either metric or inch tubing by choosing the appropriate braze sleeve.

The braze sleeve is of the same design for both the metric and standard (inch) Seal-Lok. The sleeve for metric tubing is identified by a small groove machined on the large diameter of the sleeve as shown in Fig. 15.

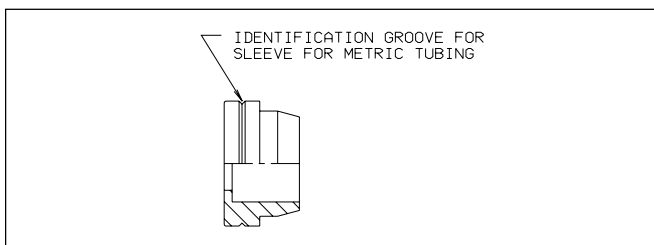

Fig. 15 — Braze Sleeve for Metric Tubing

The braze sleeve provides three basic functions:

- A leak free attachment to tube via silver brazing¹
- A flat and smooth sealing face for the O-ring
- A flat and smooth contact shoulder for the nut to connect the tube to the fitting body

Thus, the sleeve is a precision machined critical component of the fitting assembly.

Seal-Lok Reducer Sleeve. The braze sleeve is available in even and reducing sizes. The reducing sleeves make it easy to “down size” a larger face seal fitting to a smaller connection.

Metric Seal-Lok Braze Connector (MMLHB3)

A braze connector is essentially a half of a union which can be brazed on to a tube. It effectively performs three functions:

1. Simplifies tube to hose connection using traditional female swivel hose ends²
2. Minimizes components when a tube union is needed
3. Facilitates line size change (increase or decrease) and minimizes the number of joints and components

Metric Seal-Lok Nut

Smaller size Seal-Lok fitting nuts are cold-formed to provide a more tightly packed grain structure, resulting in a much stronger component. Larger size nuts are machined from cold drawn barstock. Nuts which are expected to go through a brazing cycle are left unplated and are made from a higher grade material to ensure adequate strength, even after being exposed to the annealing temperatures associated with furnace brazing.

Standard material specification. The standard materials used in the manufacture of Metric Seal-Lok fittings are shown in Table I1.

Seal-Lok Fitting	Steel		Stainless Steel	
	ASTM	Type	ASTM	Type
Forged Bodies	A576	1214/1215	A182	316
Bar Stock Bodies	A108	12L14	A479	316
Cold Formed Nuts*	A576	C1010	A479	316L
Machined Nuts*	A108	12L14	A479	316
	A108	11L37**		
Braze Sleeves	A108	12L14	A262	316L
Braze Connectors	A108	12L14	A262	316L
Flange Sleeves	A108	12L14	A479 or	316 or
			A262	316L

Table I1 — Standard Material Specifications for Metric Seal-Lok Fittings

*All SS nuts are coated to prevent galling at assembly.

**For use with copper braze tube assembly.

Note: Metric Seal-Lok fittings can be produced from other materials upon request.

Finish: Zinc with yellow chromate is used on all standard steel products. Stainless steel fittings are passivated.

Conformance Standards

Approvals

DET Norske Veritas — Approved for use in hydraulic systems up to size 38mm O.D. (1 1/2") as shown on certificate P-9538.

Specifications

ISO and SAE Standards. Metric Seal-Lok fittings meet or exceed all requirements of ISO 8434-3 and SAE J1453.

¹ Standard sleeves are designed for silver brazing.

² A more reliable and less expensive tube to hose connection can be achieved by going to a swivel tube end using Parflange and a rigid male hose end.

How Metric Seal-Lok Fittings Work

The Metric Seal-Lok fitting body face contains a high durometer O-ring that is held captive in a precision machined groove. In case of the flanged tube assemblies, the flange sleeve is attached to the tube by flanging the tube end with the Parflange machine. In the case of the brazed style tube assemblies, the flat faced sleeve is silver brazed onto the hydraulic tubing. As the nut is tightened onto the fitting body, the O-ring is compressed between the fitting body and the flat face of the sleeve to form a tight, positive seal.

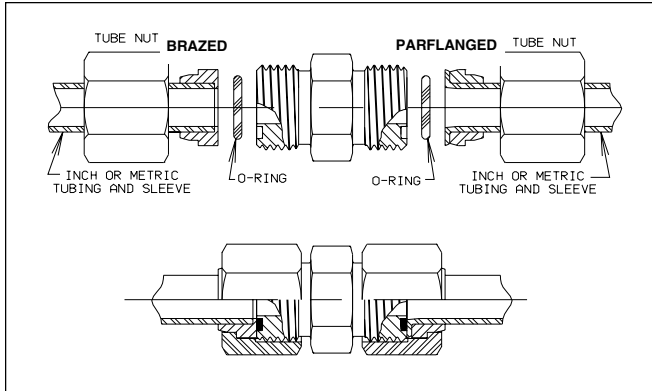

Fig. 16 — Flange and Braze Style Seal-Lok Fitting Components and Assembly.

As the two faces come in contact, further tightening of the nut produces a sharp rise in assembly torque. A solid pull of the wrench at this point, to the recommended assembly torque, completes the assembly.

The sharp torque rise gives a “solid feel” at assembly, and minimizes the possibility of over tightening.

Because the sealing surfaces are flat and perpendicular to the assembly pull, they remain virtually free of distortion during assembly, giving Seal-Lok fittings virtually unlimited remakeability. The O-ring should be inspected at each disassembly and replaced when necessary.

Tube Flanging with the Parker Parflange Machines

The Parflange machine is designed to flange tubing, specifically for use with Parker Seal-Lok (O-ring Face Seal) fittings. Parker offers the bench mount model called **Parflange 1025**, shown in Fig. 17. Also available is the more versatile, fully automatic, high speed **Parflange 1040**, whose features are discussed later in this section. All models of Parflange machines can be found on [pages N25 through N27](#).

The Parflange machines utilize an orbital cold flow forming process to produce a flat, smooth, rigidly supported 90° sealing surface on the tube end. Flanging with Parflange eliminates the need for welding or brazing of the sleeve to the tube end. Some of the many advantages of flanging with Parflange over welding or brazing follow.

- The Parflange process is several times faster than most welding or brazing methods. For instance, the 1025 and 1040 models produce flanges at a rate of 9 to 12 times the speed of comparable induction brazing.
- The Parflange process does not require any special pre- or post-flange cleaning of the tube and sleeve.
- Unlike brazing, the Parflange process does not require any flux, braze alloy, post braze cleaner or rust inhibitor. An environmentally safe lubricant applied to the flanging pin is the only additive associated with the Parflange.
- The Parflange process is environmentally clean and safe. It does not require open flame or any form of heating. Additionally, there is no emission of hazardous fumes, as is typical with welding and brazing.
- The Parflange process uses only a fraction of the energy needed for welding or brazing.
- The Parflange process accommodates the use of plated or unplated components (i.e. tube and sleeve). Thus, the need to electroplate assemblies only after fabrication is largely eliminated.
- The Parflange process eliminates the potential leak path present at the braze or weld joint.
- The Parflange process produces a burnished sealing surface, typically much smoother than the 125 micro-inch requirement of SAE J1453.

Users of Parflange and Parker's Seal-Lok (O-ring Face Seal) fitting enjoy all the inherent sealing, reliability, time and cost saving benefits, without the many drawbacks which accompany welding or brazing.

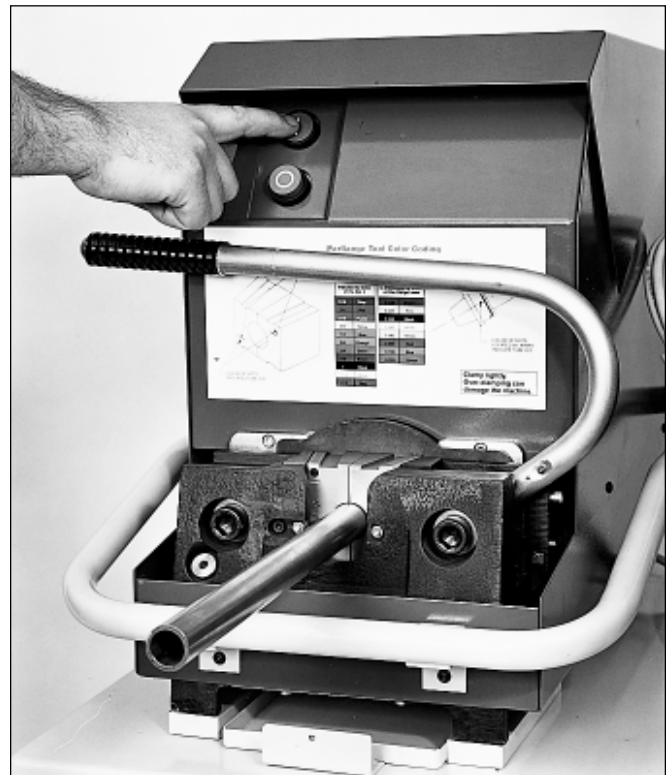

Fig. 17 — Parflange 1025

The **Parflange 1040** machine was developed based on feedback from a wide range of customers. Some of the customer suggested features found on 1040 are:

- Automatic lubrication for the flanging pin.
- Independent and automatic hydraulic tube clamping and releasing system.
- Programmable micro-processor control.
- Capacity for flanging heavier tube walls.
- No need for die removal in separating the flanged tube assembly from the clamping mechanism
- Optional automatic sleeve loader and bowl feeder for high production use.

These features designed into the 1040 result in time savings, lower risk of error by the operator and maintenance of the proven flange integrity provided by Parflange.

When fitted with the optional automatic sleeve loader, the **Parflange 1040** is suitable for high production use. The typical “floor-to-floor” cycle time for flanging with the loader in place is 15 seconds. The automatic sleeve loader is recommended for high volume producers, such as: commercial tube fabricators, large scale manufacturers doing in-house tube fabrication, etc.

For light to moderate tube users, the loader may not be necessary. Flanging without the loader requires manual loading of the sleeve into the die. The floor-to-floor cycle time is therefore more dependent on the speed of the operator. The flange quality is the same whether or not the loader is used. See Bulletin 4350-1040A-USA for instructions on operating the Parflange 1040.

The **Parflange 1025** is a compact bench or cart mountable tube flanging/flaring machine. The 1025 unit is simple to operate; it has several fail proof features and is currently the lowest priced Parflange machine. This machine is especially suited for the light to medium level users involved in original equipment manufacturing, in-plant installations, in-the-field tube fabrication, on-site repairs, shipboard tube fabrication, and so-forth. The 1025 has a smaller power unit than the 1040, and is therefore not capable of flanging heavy wall tubing in the larger tube outside diameters. See Bulletin 4390-1025A-USA for instructions on operating the Parflange 1025.

The Parflange machine is presently suitable for flanging imperial size tubing of 1/4" through 1 1/2" O.D. and metric tubing having O.D. of 6mm through 38mm. The machine has the capability of flanging tubing made from carbon steel, stainless steel, aluminum, copper-nickel, nickel-copper (monel), copper and most other metallic materials. Tooling for flanging steel tubing and many of the more popular sizes of stainless steel tubing is readily available. Tooling for flanging other materials or other sizes can be developed on an “as requested” basis.

All Parflange machines are also equipped to make 37° tube flare for use with Parker Triple-Lok fittings. The tube materials and tube O.D.'s for 37° flaring are similar to those recommended for flanging.

Tube End Preparation

1. Determine the extra tube cut-off length for the Parflange operation using [Table I3](#). (Refer to the “Table Notes” for practices in measuring.)
2. Cut tube squarely (within ± 1 degree) using a circular toothed cut-off saw or a hacksaw with a fine tooth blade.
3. Deburr the O.D. and I.D. of the tube, but avoid exceeding a chamfer of $45^\circ \times 0.020$ " on the O.D.
4. Remove all loose burrs from the tube end.

Flanging

1. Measure the tube O.D. and wall thickness and select the matching pin and die set. Each set is color-coded designating the tube O.D. and wall thickness.
2. Flange the tube end as shown in [Fig. I7](#), assuring that the pin and die set are in place within the Parflange machine. The Parflange sleeve must be positioned within the die prior to flanging. For tubing that is pre-bent to 90° , refer to [Table I4](#) for the minimum straight-length dimension to start of bend.
3. Inspect the flange diameter using [Table I2](#). The sleeve can also be used for a quick check of the flange dimension as shown in [Figure I8](#). If the flange is undersized or oversized, the depth of the grub screws, located on the die, can be adjusted by using a 5/16" nut driver and shims. Removing shims will increase the flange diameter — adding will decrease the flange diameter.

Inch Tube O.D. (in)	Metric Tube O.D. (mm)	Flange Diameter (in)
1/4	6	.473 / .502
3/8	8, 10	.584 / .620
1/2	12	.709 / .745
5/8	14, 15, 16	.875 / .923
3/4	18, 20	1.048 / 1.097
1	22, 25	1.298 / 1.347
1-1/4	28, 30, 32	1.549 / 1.597
1-1/2	35, 38	1.861 / 1.910

Table I2 — Flange Dimensions

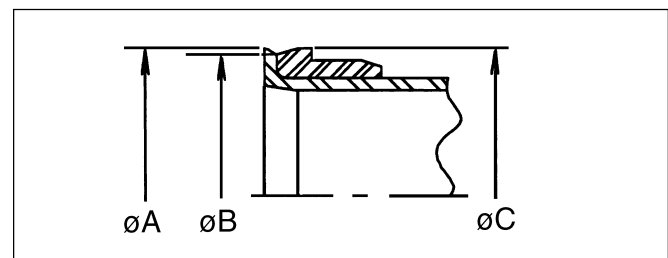
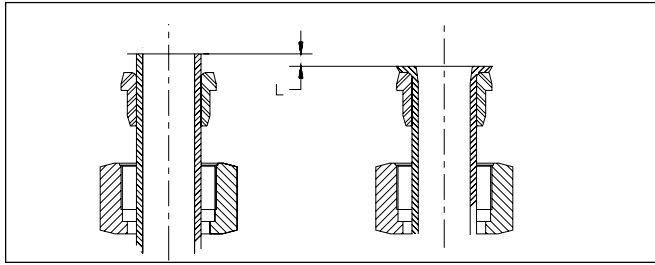

Fig. I8 — Visual Inspection: Diameter A should fall between diameters B and C

Extra Tube Cut-Off Length Guide

For tube flanging, the extra tube cut-off lengths shown in [Table I3](#) (including the notes) are required.



Extra Tube Cut-Off Length, L for Metric Tube 90° Flanging

Tube Wall Thickness (mm)	Metric Tube Outside Diameter (mm)															
	6	8	10	12	14	15	16	18	20	22	25	28	30	32	35	38
1.0	4.5 11/64	5.5 7/32	2.5 3/32	3.5 9/64	---	5.0 13/64										
1.5	5.5 7/32	5.0 13/64	4.0 5/32	4.5 11/64	4.5 11/64	4.5 11/64	3.0 1/8	6.0 15/64								
2.0			3.5 9/64	4.5 11/64	4.5 15/64	6.0 13/64	3.0 1/8	5.5 7/32	4.0 5/32	6.5 1/4	4.5 11/64	6.0 15/64	5.0 13/64	---	---	5.5 7/32
2.5				4.5 11/64	5.5 7/32	5.0 13/64	3.5 9/64	6.5 1/4	4.0 5/32	7.0 9/32	4.5 11/64	7.5 19/64	5.5 7/32	---	---	---
3.0							3.0 1/8	6.0 15/64	4.0 5/32	7.0 9/32	4.5 11/64	7.0 9/32	5.0 13/64	4.0 5/32	7.0 9/32	5.0 13/64
3.5									4.0 5/32	---	4.5 11/64	---	---	---	---	---
4.0									3.5 9/64	---	4.5 11/64	---	5.5 7/32	4.0 5/32	---	5.0 13/64
5.0											4.0 5/32	---	---	---	---	5.0 13/64

Table I3 — Extra Tube Cut-Off Length Guide

Minimum Straight-Length to Start of Bend

For tube flanging, the minimum straight-length to start of bend is shown in [Table I4](#).

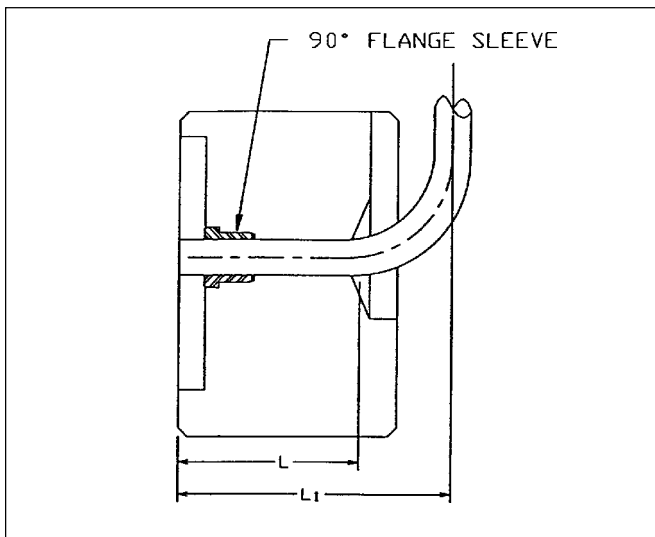

Minimum straight length to start of bend for 90° flanging

Table Notes:

1. Millimeter lengths are rounded to the nearest 0.5mm. Fractions are in inch and rounded to the nearest 1/64. Metric and inch values are not based on unit conversions.
2. This chart is only a guide. Actual dimensions may be different from those shown because of variations in tube wall thickness, inconsistency in quality of tube cut-off, deburr, and occasional modifications to the Parflange tooling. User should verify actual extra tube cut-off length (with one or two flanges before large scale flanging).

For extra tube cut-off lengths for inch tubing, refer to [Table B2](#) on page B8.

Tube O.D. Inch Sizes	Tube O.D. Metric Sizes	*L		**L1	
		(Inch)	(mm)	(Inch)	(mm)
1/4"	6	1 5/16	35	3 1/8	79
5/16"	8	1 5/16	35	3 5/32	80
3/8"	10	1 5/16	40	3 3/16	81
1/2"	12	1 3/8	40	3 1/4	82
	15	1 3/8	40	3 5/16	84
5/8"	16	1 1/2	41	3 5/16	84
	18	1 5/8	42	3 11/32	85
3/4"	20	1 3/4	50	3 3/8	86
	22	1 7/8	50	3 7/16	87
1"	25	1 7/8	50	3 1/2	89
	28	1 7/8	50	3 9/16	90
1 1/4"	30	1 7/8	50	3 19/32	91
	32	1 7/8	50	3 5/8	92
	35	2	50	3 11/16	94
1 1/2"	38	2	50	3 3/4	95

Table I4 — Minimum straight length to start of bend for 90° flanging

Notes:

- * L is the minimum straight length to the start of tube bend.
- ** L₁ is the minimum centerline dimension necessary for 90° bent tube to clear the frame of the 1040 machine. In bending of the tubes, use radius blocks which will ensure that L₁ dimensions are met or exceeded.

Tube Brazing

Silver brazing is the recommended joining method for attaching the braze style sleeve or braze connector to a tube. This process may be accomplished by using either a torch, such as the Parker Multi-Flame Torch (see Fig. 19) or an induction brazing system.

Caution: Silver brazing, as with any other form of brazing or welding, can be dangerous to your health. Proper precaution should be taken during brazing to avoid personal injury and/or over exposure to dangerous fumes.

Note: For maximum joint strength and integrity, braze carbon steel sleeves and connectors to carbon steel tube, and stainless steel sleeves and connectors to stainless steel tube. Mixing tube and sleeve materials affects the required joint clearance at brazing temperature because of their different thermal expansion rates.

Tube End Preparation

The preparation of the tube end to be brazed is a very important step in the brazing process.

1. Ensure that the tube end is cut squarely (i.e. within $\pm 1^\circ$).
2. Deburr the O.D. and I.D. of the tube but avoid exceeding a chamfer of $45^\circ \times 0.020"$ on the O.D.
3. Remove all oil and oxide build-up from the end of the tube for at least the length of the braze joint. Oil may be removed by using an oil-free solvent. Oxide build-up may be removed by pickling or by lightly sanding with an "aluminum-free" emery paper.

Selecting and Installing Braze Rings

With Parker's pre-formed silver braze rings (SBR) all that is required is to select the correct size based on the tube O.D. and to select the correct alloy composition based on the materials being joined. SBR-SS or SBR may be used for joining carbon steel tubing but only SBR-SS should be used for brazing when any stainless steel tubing is involved. SBR-SS contains nickel which retards interface corrosion typically experienced in stainless steel brazed joints when exposed to a corrosive media.

Insert the proper braze ring into the braze socket of the sleeve or braze connector that has been cleaned with solvent to remove the protective oil coating.

Selecting and Applying Flux

During the heating process, flux helps prevent oxidation of the metal surfaces, dissolves residual oxides and cleans the surface to help the alloy flow. Flux, in some cases, will also serve as a temperature indicator by becoming transparent at about the same temperature that the braze alloy will melt. Various fluxes are available with different temperature ratings.

Parker flux is available in paste form. The Parker black flux may be used in either silver brazing stainless steel or carbon steel.

Prior to heating, flux can be applied to the braze joint by any combination of brushing, dipping or spraying. All surfaces that are required to be oxide free such as the flat face of the sleeve, the O-ring groove and threads of the braze connector should be covered with flux. Additionally, the entire braze joint area should be covered with flux.

Fixturing the Parts for Brazing

Care should be taken so the braze fixture allows the sleeve to settle and bottom on the tube completely after heating. Since the Seal-Lok fitting sleeve is designed for a close fit, this should happen easily. Short tubes can be brazed in the vertical position, with slight pressure on the fitting being sufficient. On longer tubes, the joint may need to be in the horizontal position. A slight spring pressure will cause the fitting to seat itself on the tube.



Fig. 19 — Multi-Flame Torch Brazing

Heating the Part

Torch Brazing: Torch brazing may be accomplished with either a single point torch, a Parker Multi-Flame Torch (see Figure 19) or a regular welding torch that has been adjusted to give a gentle flame. A multi-point torch is strongly recommended for brazing sizes 20 mm and above because of the uniform heat produced.

Proper brazing involves heating the assembly to brazing temperature and flowing the filler metal through the joint. Heat should be applied broadly and uniformly to the tube as well as the Seal-Lok fitting. Keep in mind that thicker fitting and tubing sections take longer to heat. The entire assembly should heat to brazing temperature at about the same time. The braze alloy will always flow towards the area of higher temperature. The pre-formed braze ring has been placed inside the joint area — the last area to reach melting temperature. Therefore, when the braze material flows to the outside of the joint, the joint is complete. If the sleeve does not settle, a slight pressure will cause the sleeve to settle completing the braze joint.

Cleaning the Brazed Joint

After stopping heat application, allow about 10 seconds for the braze alloy to solidify. Then, immerse the joint in hot water (approx. 140°F). To make cleaning easier, add Parker Braze Cleaner to the hot water. This sudden cooling cracks the braze flux residue, making it easier to remove.

Any remaining residue can be removed by careful wire brushing, making sure not to scratch the sealing surface of the sleeve.

Braze Examination

Inspect the braze for a fillet all the way around the tube at the far end (small diameter) of the sleeve.

Caution: It there are gaps in the fillet, the joint may not be sound. In this case, rebrazing is recommended.

If there is build-up, remove it with emery paper being careful not to scratch the sealing surface. If this is not possible, remove the old sleeve and re-braze a new one in its place.

Corrosion Protection After Brazing

This is an extremely important step following brazing and even more so following the use of a braze cleaner.

Braze cleaners such as Handy and Harman Post Braze Cleaner available from Parker and Bernite 45¹, used to facilitate the removal of residual flux after brazing, are generally corrosive. The residue left on the surface by the cleaner especially on the I.D. of the tube, can cause rusting in carbon steel tubes rather quickly, if it is not neutralized. Therefore, it is important to neutralize the cleaner residue after cleaning with a solution such as Bernite 136² (mix 4 oz's. of Bernite 136 with one gallon of water).

If the brazed parts are not to be used soon after brazing, a coating of rust inhibitors such as WD-40³ or SP-350⁴ is recommended for the braze and heat affected area.

^{1&2} Products of Bernite Products Inc., 84 New York, Westbury, NY 11500 (516) 338-4646.

³ A product of WD-40 Company, San Diego, CA 92220.

⁴ A product of CRC Chemicals, USA, Warminster, PA 18974 (215) 674-4300.

Assembly

Ensure that the correct O-ring is properly placed in the face seal O-ring groove. It is recommended that a CORG assembly tool (see Fig. I10) be used when installing the O-ring into Seal-Lok Captive O-ring Groove (CORG). Additional information on the assembly tool can be found on page N55. The steps for using the CORG assembly tool are:

1. Position the O-ring inside the CORG assembly tool against the pusher.
2. Position the tool over the Seal-Lok tube end until the end is bottomed in the tool.
3. Push the pusher of the tool until the O-ring is released into the groove.

Place the tube assembly against the fitting body so that the flat face of the sleeve (or flanged tubing) comes in full contact with the O-ring. Thread the nut by hand to the finger tight position. Now, wrench tighten the nut to the recommended torque or F.F.W.R. (flats from wrench resistance) from Table 15.



Figure I10 — O-Ring Installation Using CORG Assembly Tool

Caution: The torque method of assembly is the preferred method of assembly. It reduces the risk of human error during assembly that is more prevalent in the Flats From Wrench Resistance (F.F.W.R.) method. To ensure the most accurate assembly of the Seal-Lok fitting it is strongly recommended that the torque method be utilized.

O.D. mm	SAE Dash Size	Tube Side Thread Size	Tube Side Assembly Torque (+10% -0%)			Flats from Wrench Resistance (F.F.W.R.)	
			in.-lb.	ft.-lb.	N-m	Tube Nuts	Swivel & Hose Ends
6	-4	9/16-18	220	18	25	1/4 to 1/2	1/2 to 3/4
8, 10	-6	11/16-16	360	30	40	1/4 to 1/2	1/2 to 3/4
12	-8	13/16-16	480	40	55	1/4 to 1/2	1/2 to 3/4
14, 15, 16	-10	1-14	—	60	80	1/4 to 1/2	1/2 to 3/4
18, 20	-12	1 3/16-12	—	85	115	1/4 to 1/2	1/3 to 1/2
22, 25	-16	1 7/16-12	—	110	150	1/4 to 1/2	1/3 to 1/2
28, 30, 32	-20	1 11/16-12	—	140	190	1/4 to 1/2	1/3 to 1/2
35, 38	-24	2-12	—	180	245	1/4 to 1/2	1/3 to 1/2

Table 15 — Metric Seal-Lok Assembly Torque and F.F.W.R.

Notes:

- 1) Fitting dash size designations are expressed in 1/16 of an inch increments. Thus -8 designates 1/2" size (8/16 = 1/2).
- 2) These torques and F.F.W.R.'s are for steel fittings, assembled dry, for full rated pressure applications.
- 3) For lower pressure applications, lower torques may be obtained by contacting the Tube Fittings Division.
- 4) See Table A36 for port assembly torques.

Tube Wall Thickness

Minimum/maximum tube wall thickness is based on the pressure holding capability of metric Seal-Lok fittings. Tubing outside the recommended range can be used. However, the pressure holding capability of the tube should be closely observed, so as not to exceed the rated pressure of the tube or fitting. Recommended min./max. tube wall thickness for each size is given in Table 16.

O.D. Size in mm	Steel, Alloy Steel, Stainless Steel, Copper, Monel	Used With Fitting Size
	Wall Thickness in mm	
6	.5 - 2.25	-4
8	1.0 - 2.5	-6
10	1.0 - 3.0	-6
12	1.0 - 3.5	-8
14	1.0 - 4.0	-10
15	1.0 - 3.0	-10
16	1.0 - 3.0	-10
18	1.0 - 3.0	-12
20	1.5 - 4.0	-12
22	1.0 - 3.0	-16
25	2.0 - 5.0	-16
28	1.5 - 5.0	-20
30	2.0 - 5.0	-20
32	2.0 - 2.5	-20
35	2.0 - 6.0	-24
38	2.5 - 7.0	-24

Table 16 — Recommended "Min./Max" Tube Wall Thickness for Metric Seal-Lok

Note: Brazing to attach sleeve can be used for all wall thicknesses. For flanging tool availability, see page N28.

Trouble Shooting

Problem/Probable Causes	Remedy	Problem/Probable Causes	Remedy
Leakage at face seal end:		Leakage at braze joint:	
Misalignment or improper fit	Align the brazed tube end and the connecting fitting properly before tightening the tube nut. Hold the flat face of the mating fitting against the O-ring while threading on the nut and wrench tightening. Ensure that the tube bends are made to the appropriate angle(s).	Improper joint clearance	Flux and reheat the joint, remove and replace with a sleeve of appropriate material and with recommended bore diameter for proper joint clearance. Repeat brazing in accordance with recommended procedures. Seal-Lok sleeves are designed for .003 to .008 diametrical joint clearance, for silver brazing, with high quality commercial hydraulic tubing.
Damaged, pinched or missing O-ring	Use a new O-ring. Properly install it in the face seal groove. Make sure that the O-ring stays in the groove while tightening the fitting. Holding the flat face of the mating fitting against the O-ring while tightening the nut will prevent the O-ring from coming out of the groove and getting pinched or falling out.	Mixing of sleeve & tube material	Do not mix sleeve and tube materials. Always use steel sleeves with steel tubing and stainless sleeves with stainless tubing. Mixing materials changes the joint clearance because of different thermal expansion characteristics of the two materials.
Extruded O-ring	Replace the O-ring and check for the following: - Proper alignment (see above) - Pressure surges in excess of 133% of rated pressure of the fitting could cause the O-ring to extrude. Tighten the nut to the recommended torque.	Improper/inadequate cleaning	First degrease the tube end and sleeve in suitable alkaline cleaner. Remove oxide build-up with aluminum free emery cloth, if needed.
Improper O-ring	Make sure the new O-ring is of the proper hardness. Standard Seal-Lok O-rings are of 90 durometer hardness.	Improper braze alloy	Use Parker (AWS A5.8 Class B GA-1), (Handy & Harman Easy Flo 45) for steel only and Parker SBR-SS (AWS A5.8 Class B Ag- 24) (Handy & Harman Braze 505) for steel or stainless steel. SBR-SS contains a small amount of nickel to prevent interface corrosion in stainless steel when exposed to corrosive media.
Pinched O-ring	An attempt to bleed off air by cracking the seal of Seal-Lok fittings can cause the O-ring to come out of its groove and get pinched. It can then extrude out under pressure. Use Parker bleed adapters for bleeding off air from the system.	Improper/inadequate flux	Apply flux liberally to the sleeve and tube end. Use AWS FB3A Parker White Flux (Handy & Harman's Handy Flux) for steel only and AWS FB3C Parker Black Flux (Handy & Harman's Type B-1) for steel or stainless steel.
Improper tightening	Check the joint for tightness. Retorque to the Parker recommended torque value. If it still leaks, it could be due to any one or combination of causes listed below. Take the joint apart and follow the recommendations listed.	Inadequate/improper braze temperature	The key is to ensure that both the tube and sleeve reach braze temperature at about the same time. A dull red color of the tube and sleeve is a good indication of adequate braze temperature at which the braze ring should melt completely. Too little heat may not melt the braze ring completely, causing incomplete braze flow. Too much heat can cause braze alloy to boil resulting in pinhole type porosity in the joint. It can also burn the flux retarding the braze flow. A complete 360° fillet at the small end of the sleeve is a good indication of full braze flow.
Braze overflow on sealing surface	Remove the affected sleeve and re-braze a new one in its place. Do not try to file, sand or grind the braze overflow. Braze alloy tends to flow in the direction of higher temperature. This overflow can occur if the seal surface is at a higher temperature than the tail end of the sleeve when the braze ring starts melting. Therefore, when the ring starts melting, the heat source should be relocated to the small diameter of the sleeve to promote braze flow through the joint.		
Damaged fitting	Check and replace fittings. Because of elastomeric seal, Seal-Lok is tolerant of minor imperfections on its sealing surface; but it cannot tolerate gross scratches, nicks, dents, etc. Damaged threads can give a false sense of joint tightness because of their poor threading ability.		

Table 17 — Trouble Shooting

Features, Advantages & Benefits

1. Manufacture — Metric Seal-Lok fittings conform to ISO 8434-3. This specification not only controls dimensions and tolerances of Metric Seal-Lok fittings, but includes minimum performance requirements. (All shaped fittings are machined from forgings for additional strength.)

2. World Standard Fitting — Metric Seal-Lok fittings conform to ISO 8434-3 and are manufactured with the preferred port end, ISO 6149-2. As a world standard fitting, Seal-Lok is suitable for a wider range of global markets.

3. Sealing Capability — An elastomeric O-ring forms the primary sealing element. The O-ring is contained within a precision machined groove on the fitting body. It is compressed into the groove by the flat face of the tube flange or braze sleeve, thus assuring leak free sealing.

4. Pressure Rating — Metric Seal-Lok fittings are the highest working pressure industrial fitting on the market, ranging from high vacuum to 9,000 psi, depending on size.

5. Vibration and Fatigue — Metric Seal-Lok fittings have been extensively used in applications that experience severe vibration and shock with no field problems.

6. Visible Inspection:

Flanged — The surface of the flange should be reasonably smooth with no deep scratches, gouges or indentations. Minor surface imperfections outside of the seal area are acceptable.

Brazed — Presence of braze alloy 360° around the back of the sleeve (tail) allows for a quick (non-destructive) check for proper braze joint attachment.

7. No Tube Entry — Tube does not enter into the body of the fitting, allowing for zero clearance, drop-in installation of components. This makes repair and maintenance very easy.

8. Assembly — A variety of sleeve attachment methods are now available. These include torch brazing, induction brazing and flanging. Metric Seal-Lok fittings can also be used as hose

adapters. Detailed assembly and inspection procedures can be found on [pages I12 through I15](#).

9. Make-Up — From the finger tight position, one short pull on the wrench gives the assembly a quick high rise to required torque. Metric Seal-Lok fittings have a solid “make-up feel” and excellent over-torque resistance.

10. Tube Wall — The brazing of the sleeve to the outside of the tube allows Metric Seal-Lok fittings to be used on thin to heavy wall tubing. Metric Seal-Lok fittings can also be used with the widest range of tubing grades.

11. Reusability/Remakeability — Metric Seal-Lok fittings can be disassembled and reassembled many times. Simply replace the O-ring on the tube end and tighten to recommended torque.

12. Temperature Range — Metric Seal-Lok fittings are suitable for sub-zero through elevated temperature applications. Service temperature is limited by the material of the chosen O-ring.

13. Materials — Metric Seal-Lok can be manufactured from a wide variety of materials. The most popular material currently used is steel. Upon request, the Tube Fittings Division can machine Metric Seal-Lok fittings from other materials.

14. Envelope Size — Redesign of hydraulic systems are normally unnecessary because Metric Seal-Lok fittings are similar in size to the most popular fitting of all, the Triple-Lok 37° flared fittings. Metric Seal-Lok fittings are excellent hose adapters.

15. Parflange Technology — Specifically designed to be used with Metric Seal-Lok fittings, the Parflange machines utilize an orbital cold flow forming process to produce a smooth, rigidly supported 90° sealing surface on the tube end. The flanged tube ends meet ISO 8434-3 for Formed Tube Connections. This patented Parflange process eliminates the need for messy and time-consuming brazing.

I

Recommended Working Pressure, PSIG

**Metric/BSP Fittings and Conversion Adapters
Metric Seal-Lok™**

These recommended working pressures represent the capability of the subject fitting. Nevertheless, in some instances, the wall thickness or type of tubing, hose, or hose connector assembled to the fitting may dictate the maximum pressure to which the assembly should be exposed. It is strongly suggested that these fitting working pressure charts be used in conjunction with appropriate pressure charts for tubing or hose during the fitting selection process.

Below is the definition of Pressure, Rated Static and Pressure, Rated Dynamic. The following values are based on a minimum design factor of 4:1 for dynamic and 3:1 for static applications.

Pressure, Rated Static – The maximum pressure that a pressure containing envelope is capable of sustaining in an application not exceeding 30,000 operating cycles in a system free of pressure surges, shocks, vibration, and temperature excursions.

Pressure, Rated Dynamic – The maximum fluctuating pressure load that a pressure containing envelope is capable of sustaining for a minimum of one million operation cycles without failure.

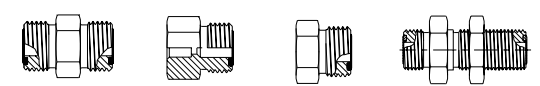

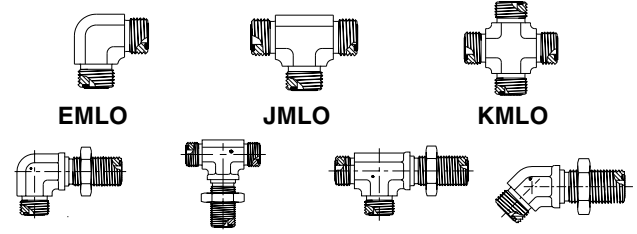
				
HMLO MMLOHB3 PNML0 WMLO				
Size	STATIC (3:1)		DYNAMIC (4:1)	
	STEEL	SS	STEEL	SS
4	12000	14400	9200	9200
6	13000	15600	9200	9200
8	12000	14400	9200	9200
10	11000	13200	6000	6000
12	11000	13200	6000	6000
16	9500	11400	6000	6000
20	8000	9600	6000	6000
24	6500	7800	5000	5000

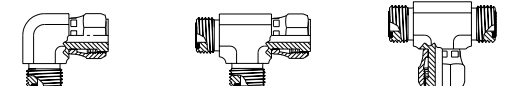
				
EMLO JMLO KMLO WEMLO WJMLO WJJMLO WNMLO				
Size	STATIC (3:1)		DYNAMIC (4:1)	
	STEEL	SS	STEEL	SS
4	12000	12000	9200	9200
6	13000	13000	9200	9200
8	12000	12000	9200	9200
10	11000	11000	6000	6000
12	11000	11000	6000	6000
16	9500	9500	6000	6000
20	8000	8000	5000	5000
24	6500	6500	4000	4000

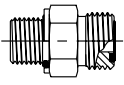
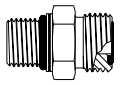
				
C6MLO R6MLO S6MLO				
SIZE	STATIC (3:1)		DYNAMIC (4:1)	
	STEEL	SS	STEEL	SS
4	12000	12000	9200	9200
6	12000	12000	9200	9200
8	12000	12000	9200	9200
10	11000	11000	6000	6000
12	11000	11000	6000	6000
14	9500	9500	6000	6000
16	9500	9500	6000	6000
20	6500	6500	4000	4000
24	5000	5000	4000	4000

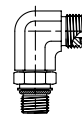
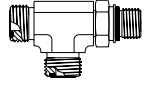
					
		F42EDMLO		F87MLO	
Size	STATIC (3:1)		DYNAMIC (4:1)		
	STEEL	SS	STEEL	SS	
4M12	12000	14400	9200	9200	
4M14	12000	14400	9200	9200	
6M12	12000	14400	9200	9200	
6M14	12000	14400	9200	9200	
6M16	12000	14400	9200	9200	
8M14	12000	14400	9200	9200	
8M18	12000	14400	9200	9200	
8M22	8000	9600	6000	6000	
10M18	8000	9600	6000	6000	
10M22	8000	9600	6000	6000	
12M22	8000	9600	6000	6000	
12M27	8000	9600	6000	6000	
12M33	8000	9600	6000	6000	
14M30	8000	9600	6000	6000	
16M33	8000	9600	6000	6000	
20M42	8000	9600	4000	4000	
24M48	6500	7800	4000	4000	

							
		C87OMLO		CC87OMLO		R87OMLO	
Size	STATIC (3:1)		DYNAMIC (4:1)				
	STEEL	SS	STEEL	SS			
4M12	8000	8000	6000	6000			
4M14	8000	8000	6000	6000			
6M12	8000	8000	6000	6000			
6M14	8000	8000	6000	6000			
6M16	8000	8000	6000	6000			
8M14	8000	8000	6000	6000			
8M18	8000	8000	6000	6000			
8M22	8000	8000	6000	6000			
10M18	8000	8000	6000	6000			
10M22	8000	8000	6000	6000			
12M22	8000	8000	6000	6000			
12M27	8000	8000	6000	6000			
12M33	6500	6500	5100	5100			
14M30	6500	6500	5100	5100			
16M33	6500	6500	5100	5100			
20M42	5000	5000	4000	4000			
24M48	5000	5000	4000	4000			

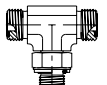
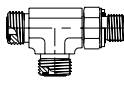
									
		C4OMLO		V4OMLO		S4OMLO		R4OMLO	
Size	STATIC		DYNAMIC						
	STEEL	SS	STEEL	SS					
4	6500	6500	5100	5100					
6	6500	6500	5100	5100					
8	6500	6500	5100	5100					
10	4800	4800	3700	3700					
12	4800	4800	3700	3700					
14	4800	4800	3700	3700					
16	4800	4800	3700	3700					
20	3300	3300	2500	2500					
24	3300	3300	2500	2500					



How To Order Metric Seal-Lok Tube Fittings

Nomenclature

Seal-Lok fitting part numbers are constructed from symbols that identify the size and style of the fitting and material used. See [pages A4 through A8](#) for complete data. The nomenclature is compressed, i.e., no dashes or spaces are utilized in the part number.

Sizes

2 through 24. (Tube sizes are determined by the number of sixteenths of an inch in the tube O.D.)
 M12 through M48. (Port sizes are determined by thread size in millimeter.)

Standard Tube and Port Sizes

Dash Size	Inch Tube O.D.	Equivalent Metric Tube O.D. mm	Corresponding Standard Port Size
-4	1/4	6	M12
-6	3/8	8, 10	M16
-8	1/2	12	M18
-10	5/8	14, 15, 16	M22
-12	3/4	18, 20	M27
-16	1	22, 25	M33
-20	1 1/4	28, 30, 32	M42
-24	1 1/2	35, 38	M48
-32	2	42, 50	M60

Material

Machined from steel as a standard.

Example

Fitting needed — Metric Seal-Lok Steel Male Connector for 1/4" O.D. Tube and M12x1.5 ISO 6149 Metric Straight Thread Port. Part number 4M12F87OMLOS.

4	M12	F	87	O	M	L	O	S
1/4" Tube O.D. (4/16")	M12x1.5 Metric Straight Thread	Male Connector	ISO 6149 Straight Thread Port	O-ring on Port End	Metric Wrench Flats	Seal-Lok	O-ring on Tube End	Steel

Order the same part without O-rings by eliminating the O's and simply use part number 4M12F87MLS. Metric Seal-Lok fittings must be ordered in its component parts. Assembled fittings are not available.

To complete a flanged assembly for metric tubing using the above part, all of the following components are required:
 4BMLS (tube nut)
 TPLS6 (Parflange sleeve for 6mm OD tube)

To complete a flanged assembly for inch tubing using the above part, all of the following components are required:
 4 BL-S (tube nut)
 4 TPL-S (Parflange sleeve for 1/4" O.D. tube)

To complete a brazed assembly for metric tubing using the above part, all of the following components are required:
 4BMLS (tube nut)
 TLS6 (Parflange sleeve for 6mm OD tube)
 SBR6 (silver braze ring for 6mm OD tube)

To complete a brazed assembly using the above part, all of the following components are required:
 4 BL-S (tube nut)
 4 TL-S (braze sleeve for 1/4" O.D. tube)
 4 SBR (silver braze ring, steel for 1/4" O.D. tube)

Crosses and Tees

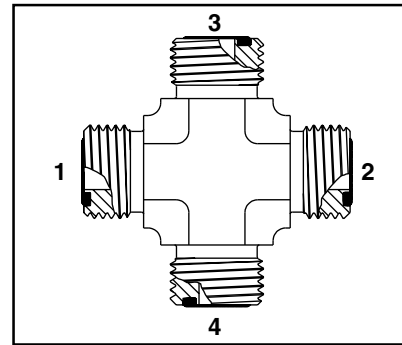

For tees: First size the run (1 to 2) and then the branch (3).
 For crosses: First size the run (1 to 2) and then the branch (3 to 4).

Special Fittings

If design or configuration is questionable, please provide a detailed sketch, drawing or sample part to the [Tube Fittings Division](#).

Special O-rings

To order stock O-rings other than standard Nitrile (e.g., Buna N) (N0552), list the Parker O-ring Division compound number after the fitting material specification.

For example:
 4M12F87OMLOS
 (N0552 O-rings supplied)
 4M12F87OMLOSV0894
 (fluorocarbon O-rings, e.g., Viton)
 4M12F87OMLOSSN0756
 (Nitrile (e.g., Buna-N) O-rings for CNG)

90° Metric Straight Thread Elbow

C87OMLO

ORFS tube end / Metric straight thread
O-ring - ISO 6149

ISO 8434-3 SDE SAE 52M0287
Part Number Information
C87ML — Body only
C87OMLO — Assembled with O-rings

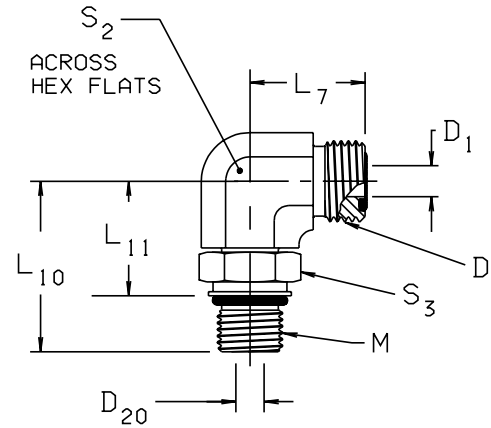

Dimensions in millimeters

TUBE FITTING PART #	TUBE O.D. (mm)	TUBE O.D. (inch)	D TUBE END UN/UNF-2A	M PORT THD ISO 261	D1 (mm)	D20 DRILL (mm)	L7 (mm)	L10 (mm)	L11 REF# (mm)	S2 (mm)	S3 HEX (mm)	STANDARD MATERIAL FROM STOCK		
												S	SS	B
4M12C87OMLO	6	1/4	9/16-18	M12X1.5	5.0	4	21.5	33.0	22.0	14	17	•		
4M14C87OMLO	6	1/4	9/16-18	M14X1.5	5.0	6	24.0	35.5	24.5	17	19	•		
6M12C87OMLO	8, 10	3/8	11/16-16	M12X1.5	6.5	4	25.0	35.5	24.5	17	17	•		
6M14C87OMLO	8, 10	3/8	11/16-16	M14X1.5	6.5	6	25.0	35.5	24.5	17	19	•		
6M16C87OMLO	8, 10	3/8	11/16-16	M16X1.5	6.5	7	25.0	37.5	25.0	17	22	•		
8M14C87OMLO	12	1/2	13/16-16	M14X1.5	9.5	6	28.0	36.0	25.0	19	19	•		
8M18C87OMLO	12	1/2	13/16-16	M18X1.5	9.5	9	28.0	41.0	27.0	19	24	•		
8M22C87OMLO	12	1/2	13/16-16	M22X1.5	9.5	12	31.0	49.0	34.0	27	27	•		
10M18C87OMLO	14, 15, 16	5/8	1-14	M18X1.5	12.5	9	33.5	47.5	33.5	37	24	•		
10M22C87OMLO	14, 15, 16	5/8	1-14	M22X1.5	12.5	12	33.5	49.0	34.0	27	27	•		
12M22C87OMLO	18, 20	3/4	1 3/16-12	M22X1.5	15.5	12	37.5	49.5	34.5	27	27	•		
12M27C87OMLO	18, 20	3/4	1 3/16-12	M27X2	15.5	15	37.5	55.5	37.0	27	32	•		
16M33C87OMLO	22, 25	1	1 7/16-12	M33X2	20.5	20	41.5	59.5	41.0	36	41	•		
20M38C87OMLO*	28, 30, 32	1 1/4	1 11/16-12	M38X2	26.0	26	44.5	62.0	43.0	41	46	•		
20M42C87OMLO	28, 30, 32	1 1/4	1 11/16-12	M42X2	26.0	26	44.5	63.0	44.0	41	50	•		
24M48C87OMLO	35, 38	1 1/2	2-12	M48X2	32.0	32	49.0	71.5	50.0	50	55	•		

See pages I34-I35 for information on replacement face seal and ISO 6149 O-rings.

* For special M38x2 (ISO 6149-1 style) port; the current ISO 6149 does not include the M38 size.
For pressure ratings, please contact the Tube Fittings Division.

Long 90° Metric Straight Thread Elbow

CC87OMLO

ORFS tube end / Metric straight thread
O-ring - ISO 6149

ISO 8434-3 SDEL SAE 52M1587

Part Number Information

CC87ML — Body only

CC87OMLO — Assembled with O-rings

Dimensions in millimeters

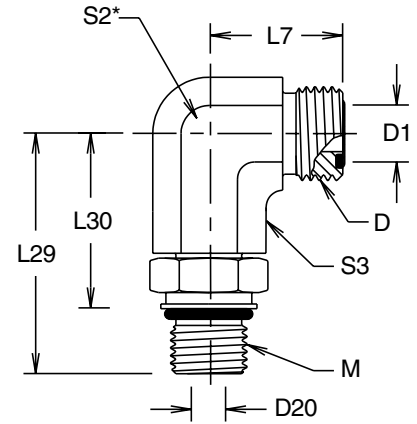

*Across Hex Flats

TUBE FITTING PART #	TUBE O.D. (mm)	TUBE O.D. (inch)	D TUBE END UN/UNF-2A	M PORT THD ISO 261	D1* DRILL (mm)	D20 DRILL (mm)	L7 (mm)	L29 (mm)	L30 (mm)	S2 (mm)	S3 HEX (mm)	STANDARD MATERIAL FROM STOCK		
												S	SS	B
4M12CC87OMLO	6	1/4	9/16-18	M12X1.5	5.0	4	21.5	56.4	23.9	14	17	•		
6M14CC87OMLO	8, 10	3/8	11/16-16	M14X1.5	6.5	6	25.0	56.4	20.9	17	19	•		
6M16CC87OMLO	8, 10	3/8	11/16-16	M16X1.5	6.5	7	25.0	66.5	29.0	17	22	•		
8M18CC87OMLO	12	1/2	13/16-16	M18X1.5	9.5	9	28.0	74.9	33.9	19	24	•		
8M22CC87OMLO	12	1/2	13/16-16	M22X1.5	9.5	12	31.0	87.9	38.9	27	27	•		
10M22CC87OMLO	14, 15, 16	5/8	1-14	M22X1.5	12.5	12	33.5	87.9	38.9	27	27	•		
12M27CC87OMLO	18, 20	3/4	1 3/16-12	M27X2	15.5	15	37.5	100.5	45.1	27	32	•		
16M33CC87OMLO	22, 25	1	1 7/16-12	M33X2	20.5	20	41.5	114.5	55.0	36	41	•		
20M42CC87OMLO	28, 30, 32	1 1/4	1 11/16-12	m42x2	26.0	26	44.5	126.5	63.5	41	50	•		

See pages I34-I35 for information on replacement face seal and ISO 6149 O-rings.

Metric Straight Thread Connector

F87OMLO

ORFS tube end / Metric straight thread O-ring - ISO 6149

ISO 8434-3 SDS SAE 52M0187

Part Number Information

F87ML — Body only

F87OMLO — Assembled with O-rings

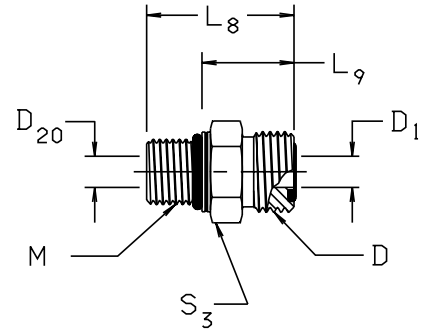

Dimensions in millimeters

TUBE FITTING PART #	TUBE O.D. (mm)	TUBE O.D. (inch)	D TUBE END UN/UNF-2A	M PORT THD ISO 261	D1 DRILL (mm)	D20 DRILL (mm)	L8 (mm)	L9 (mm)	S3 HEX (mm)	STANDARD MATERIAL FROM STOCK		
										S	SS	B
4M12F87OMLO	6	1/4	9/16-18	M12X1.5	5.0	4.0	28.5	17.5	17	•		
4M14F87OMLO	6	1/4	9/16-18	M14X1.5	5.0	6.0	29.5	18.5	19	•		
6M12F87OMLO	8, 10	3/8	11/16-16	M12X1.5	6.5	4.0	32.0	21.0	19	•		
6M14F87OMLO	8, 10	3/8	11/16-16	M14X1.5	6.5	6.0	32.0	21.0	19	•		
6M16F87OMLO	8, 10	3/8	11/16-16	M16X1.5	6.5	7.0	33.5	21.0	22	•		
6M18F87OMLO	8, 10	3/8	11/16-16	M18X1.5	6.5	9.0	36.0	22.0	24	•		
8M14F87OMLO	12	1/2	13/16-16	M14X1.5	9.5	6.0	35.0	24.0	22	•		
8M16F87OMLO	12	1/2	13/16-16	M16X1.5	9.5	7.0	36.5	24.0	24	•		
8M18F87OMLO	12	1/2	13/16-16	M18X1.5	9.5	9.0	38.0	24.0	24	•		
8M22F87OMLO	12	1/2	13/16-16	M22X1.5	9.5	9.5	39.5	27.0	27	•		
8M27F87OMLO	12	1/2	13/16-16	M27X2.0	9.5	9.5	44.0	25.5	32	•		
10M18F87OMLO	14, 15, 16	5/8	1-14	M18X1.5	12.5	9.0	41.0	27.0	27	•		
10M22F87OMLO	14, 15, 16	5/8	1-14	M22X1.5	12.5	12.0	42.0	27.0	27	•		
12M22F87OMLO	18, 20	3/4	1 3/16-12	M22X1.5	15.5	12.0	45.0	30.0	32	•		
12M27F87OMLO	18, 20	3/4	1 3/16-12	M27X2	15.5	15.0	48.5	30.0	32	•		
12M33F87OMLO	18, 20	3/4	1 3/16-12	M33X2.0	15.5	20.0	51.5	33.0	41	•		
16M33F87OMLO	22, 25	1	1 7/16-12	M33X2	20.5	20.0	52.0	33.5	41	•		
20M38F87OMLO**	28, 30, 32	1 1/4	1 11/16-12	M38X2	26.0	26.0	53.0	34.5	46	•		
20M42F87OMLO	28, 30, 32	1 1/4	1 11/16-12	M42X2	26.0	26.0	54.5	35.5	50	•		
24M48F87OMLO	35, 38	1 1/2	2-12	M48X2.0	32.0	32.0	57.0	35.5	55	•		



See pages I34-I35 for information on replacement face seal and ISO 6149 O-rings.

*Manufacturing option permits a single drill through equal to the smaller of D1 and D20.

**For special M38x2 (ISO 6149-1 style) port; the current ISO 6149 does not include the M38 size. For pressure ratings, please contact the Tube Fittings Division.

Metric Straight Thread Branch Tee

S87OMLO

ORFS tube ends / Metric straight thread O-ring - ISO 6149

ISO 8434-3 SDBT SAE 52M0489

Part Number Information

S87ML — Body only

S87OMLO — Assembled with O-rings

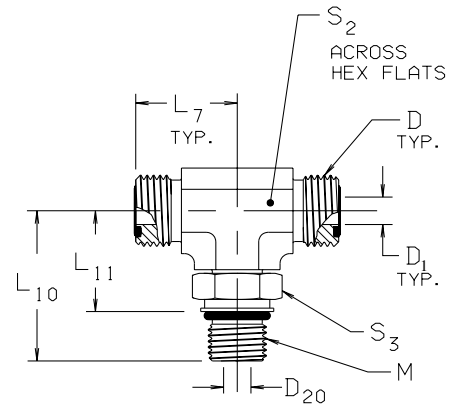

Dimensions in millimeters

TUBE FITTING PART #	TUBE O.D. (mm)	TUBE O.D. (inch)	D TUBE END UN/UNF-2A	M PORT THD ISO 261	D1 DRILL (mm)	D20 DRILL (mm)	L7 (mm)	L10 (mm)	L11 AFTER ASSY (mm)	S2 (mm)	S3 HEX (mm)	STANDARD MATERIAL FROM STOCK		
												S	SS	B
4M12S87OMLO	6	1/4	9/16-18	M12X1.5	5.0	4	21.5	33.0	22.0	14	17			
4M14S87OMLO	6	1/4	9/16-18	M14X1.5	5.0	6	24.0	35.5	24.5	17	19	•		
6M14S87OMLO	8, 10	3/8	11/16-16	M14X1.5	6.5	6	25.0	35.5	24.5	19	19	•		
6M16S87OMLO	8, 10	3/8	11/16-16	M16X1.5	6.5	7	25.0	37.5	25.0	17	22	•		
8M14S87OMLO	12	1/2	13/16-16	M14X1.5	9.5	6	28.0	36.0	25.0	19	19	•		
8M18S87OMLO	12	1/2	13/16-16	M18X1.5	9.5	9	28.0	41.0	27.0	19	24	•		
8M22S87OMLO	12	1/2	13/16-16	M22X1.5	9.5	12	31.0	49.0	34.0	27	27	•		
10M22S87OMLO	14, 15, 16	5/8	1-14	M22X1.5	12.5	12	33.5	49.0	34.0	27	27	•		
12M27S87OMLO	18, 20	3/4	1 3/16-12	M27X2	15.5	15	37.5	55.5	37.0	30	32	•		
16M33S87OMLO	22, 25	1	1 7/16-12	M33X2	20.5	20	41.5	59.5	41.0	36	41	•		
20M42S87OMLO	28, 30, 32	1 1/4	1 11/16-12	M42X2	26.0	26	44.5	63.0	44.0	41	50	•		

See pages I34-I35 for information on replacement face seal and ISO 6149 O-rings.

Metric Straight Thread Run Tee

R87OMLO

ORFS tube ends / Metric straight thread O-ring - ISO 6149

ISO 8434-3 SDRT SAE 52M0488

Part Number Information

R87ML — Body only

R87OMLO — Assembled with O-rings

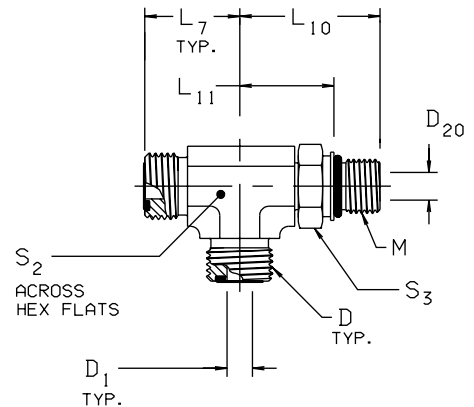

Dimensions in millimeters

TUBE FITTING PART #	TUBE O.D. (mm)	TUBE O.D. (inch)	D TUBE END UN/UNF-2A	M PORT THD ISO 261	D1 DRILL (mm)	D20 DRILL (mm)	L7 (mm)	L10 (mm)	L11 AFTER ASSY (mm)	S2 (mm)	S3 HEX (mm)	STANDARD MATERIAL FROM STOCK		
												S	SS	B
4M12R87OMLO	6	1/4	9/16-18	M12X1.5	5.0	4	21.5	33.0	22.0	14	17	•		
4M14R87OMLO	6	1/4	9/16-18	M14X1.5	5.0	6	24.0	35.5	24.5	17	19	•		
6M14R87OMLO	8, 10	3/8	11/16-16	M14X1.5	6.5	6	25.0	35.5	24.5	19	19	•		
6M16R87OMLO	8, 10	3/8	11/16-16	M16X1.5	6.5	7	25.0	37.5	25.0	19	22	•		
8M14R87OMLO	12	1/2	13/16-16	M14X1.5	9.5	6	28.0	36.0	25.0	19	19	•		
8M18R87OMLO	12	1/2	13/16-16	M18X1.5	9.5	9	28.0	41.0	27.0	19	24	•		
8M22R87OMLO	12	1/2	13/16-16	M22X1.5	9.5	12	31.0	49.0	34.0	27	27	•		
10M22R87OMLO	14, 15, 16	5/8	1-14	M22X1.5	12.5	12	33.5	49.0	34.0	27	27	•		
12M27R87OMLO	18, 20	3/4	1 3/16-12	M27X2	15.5	15	37.5	55.5	37.0	30	32	•		
16M33R87OMLO	22, 25	1	1 7/16-12	M33X2	20.5	20	41.5	59.5	41.0	36	41	•		
20M42R87OMLO	28, 30, 32	1 1/4	1 11/16-12	M42X2	26.0	26	44.5	63.0	44.0	41	50	•		
24M28R87OMLO	35, 38	1 1/2	2-12	M48X2	32.0	32	49.0	71.5	50.0	50	55	•		

See pages I34-I35 for information on replacement face seal and ISO 6149 O-rings.

45° Metric Straight Thread Elbow V87OMLO

ORFS tube end / Metric straight thread - ISO 6149

ISO 8434-3 SDE45 SAE 52M0387

Part Number Information

V87ML — Body only

V87OMLO — Assembled with O-rings

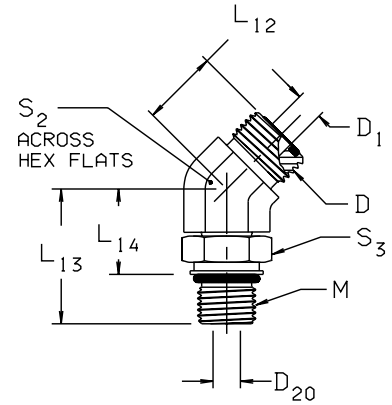

Dimensions in millimeters

TUBE FITTING PART #	TUBE O.D. (mm)	TUBE O.D. (inch)	D TUBE END UN/UNF-2A	M PORT THD ISO 261	D1 DRILL (mm)	D20 DRILL (mm)	L12 (mm)	L13 (mm)	L14 AFTER ASSY (mm)	S2 (mm)	S3 HEX (mm)	STANDARD MATERIAL FROM STOCK		
												S	SS	B
4M12V87OMLO	6	1/4	9/16-18	M12X1.5	5.0	4	16.0	30.0	19.0	14	17	•		
4M14V87OMLO	6	1/4	9/16-18	M14X1.5	5.0	6	18.0	31.5	20.5	17	19	•		
6M16V87OMLO	8, 10	3/8	11/16-16	M16X1.5	6.5	7	19.0	33.5	21.0	17	22	•		
8M18V87OMLO	12	1/2	13/16-16	M18X1.5	9.5	9	20.5	37.0	23.0	19	24	•		
10M22V87OMLO	14, 15, 16	5/8	1-14	M22X1.5	12.5	12	23.5	44.0	29.0	27	27	•		
12M27V87OMLO	18, 20	3/4	1 3/16-12	M27X2	15.5	15	26.0	50.5	32.0	27	32	•		
16M33V87OMLO	22, 25	1	1 7/16-12	M33X2	20.5	20	30.0	52.5	34.0	36	41	•		
20M42V87OMLO	28, 30, 32	1 1/4	1 11/16-12	M42X2	26.0	26	32.0	54.0	35.0	41	50	•		
24M48V87OMLO	35, 38	1 1/2	2-12	M48X2	32.0	32	37.0	56.5	35.0	50	55	•		

See pages I34-I35 for information on replacement face seal and ISO 6149 O-rings.

Swivel Nut Elbow C6MLO

ORFS swivel / ORFS tube end

ISO 8434-3 SWE SAE 52M0221

Part Number Information

C6MO — Body only

C6MLO — Assembled with O-ring

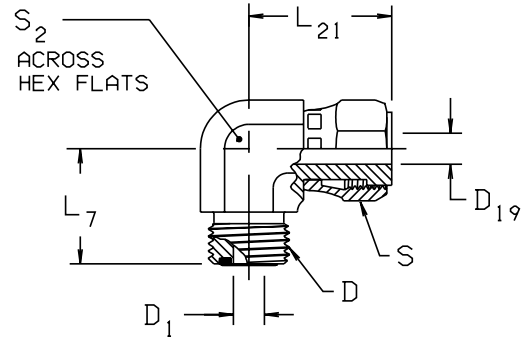

Dimensions in millimeters

TUBE FITTING PART #	TUBE O.D. (mm)	TUBE O.D. (inch)	D TUBE END UN/UNF-2A	D1 DRILL (mm)	D19 (mm)	L7 (mm)	L21 (mm)	S HEX (mm)	S2 (mm)	STANDARD MATERIAL FROM STOCK		
										S	SS	B
4C6MLO	6	1/4	9/16-18	5.0	4.0	21.5	26.5	17	14	•		
6C6MLO	8, 10	3/8	11/16-16	6.5	6.5	25.0	29.0	22	17	•		
8C6MLO	12	1/2	13/16-16	9.5	9.0	28.0	38.0	24	19	•		
10C6MLO	14, 15, 16	5/8	1-14	12.5	11.5	33.5	41.0	30	24	•		
12C6MLO	18, 20	3/4	1 3/16-12	15.5	14.0	37.5	46.5	36	27	•		
16C6MLO	22, 25	1	1 7/16-12	20.5	20.0	41.5	53.5	41	36	•		
20C6MLO	28, 30, 32	1 1/4	1 11/16-12	26.0	26.0	44.5	58.0	50	41	•		
24C6MLO	35, 38	1 1/2	2-12	32.0	32.0	49.0	61.0	60	50	•		

See page I34 for information on replacement face seal O-rings.

Swivel Nut Branch Tee

S6MLO

ORFS swivel / ORFS tube ends

ISO 8434-3 SWBT SAE 52M0433

Part Number Information

S6ML — Body only

S6MLO — Assembled with O-rings

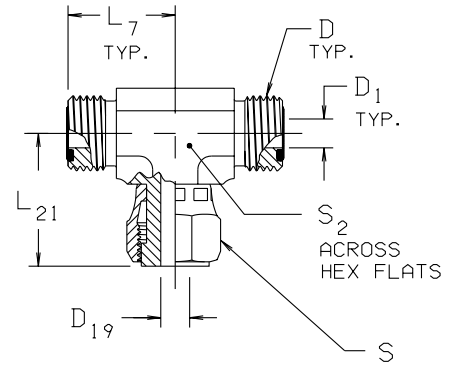

Dimensions in millimeters

TUBE FITTING PART #	TUBE O.D. (mm)	TUBE O.D. (inch)	D TUBE END UN/UNF-2A	D1 DRILL (mm)	D19 DRILL (mm)	L7 (mm)	L21 (mm)	S HEX (mm)	S2 (mm)	STANDARD MATERIAL FROM STOCK		
										S	SS	B
4S6MLO	6	1/4	9/16-18	5.0	4.0	21.5	26.5	17	14	•		
6S6MLO	8, 10	3/8	11/16-16	6.5	6.5	25.0	29.0	22	17	•		
8S6MLO	12	1/2	13/16-16	9.5	9.0	28.0	38.0	24	19	•		
10S6MLO	14, 15, 16	5/8	1-14	12.5	11.5	33.5	41.0	30	24	•		
12S6MLO	18, 20	3/4	1 3/16-12	15.5	14.0	37.5	46.5	36	27	•		
16S6MLO	22, 25	1	1 7/16-12	20.5	20.0	41.5	53.5	41	36	•		
20S6MLO	28, 30, 32	1 1/4	1 11/16-12	26.0	26.0	44.5	58.0	50	41	•		
24S6MLO	35, 38	1 1/2	2-12	32.0	32.0	49.0	61.0	60	50	•		

See page I34 for information on replacement face seal O-rings.

Swivel Nut Run Tee

R6MLO

ORFS swivel / ORFS tube ends

ISO 8434-3 SWRT SAE 52M0432

Part Number Information

R6ML — Body only

R6MLO — Assembled with O-rings

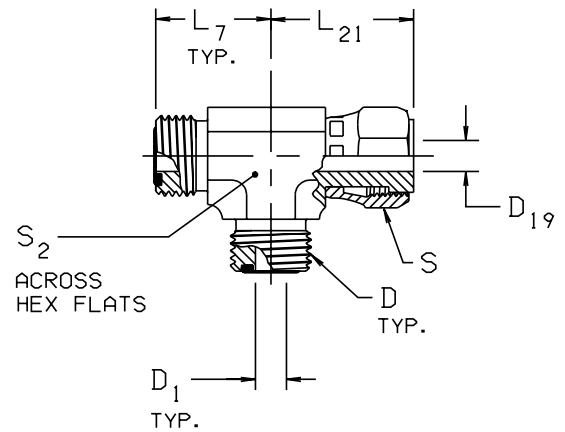

Dimensions in millimeters

TUBE FITTING PART #	TUBE O.D. (mm)	TUBE O.D. (inch)	D TUBE END UN/UNF-2A	D1 DRILL (mm)	D19 DRILL (mm)	L7 (mm)	L21 (mm)	S HEX (mm)	S2 (mm)	STANDARD MATERIAL FROM STOCK		
										S	SS	B
4R6MLO	6	1/4	9/16-18	5.0	4.0	21.5	26.5	17	14	•		
6R6MLO	8, 10	3/8	11/16-16	6.5	6.5	25.0	29.0	22	17	•		
8R6MLO	12	1/2	13/16-16	9.5	9.0	28.0	38.0	24	19	•		
10R6MLO	14, 15, 16	5/8	1-14	12.5	11.5	33.5	41.0	30	24	•		
12R6MLO	18, 20	3/4	1 3/16-12	15.5	14.0	37.5	46.5	36	27	•		
16R6MLO	22, 25	1	1 7/16-12	20.5	20.0	41.5	53.5	41	36	•		
20R6MLO	28, 30, 32	1 1/4	1 11/16-12	26.0	26.0	44.5	58.0	50	41	•		
24R6MLO	35, 38	1 1/2	2-12	32.0	32.0	49.0	61.0	60	50	•		

See page I34 for information on replacement face seal O-rings.

Union Elbow EMLO

90° ORFS tube end (both ends)

ISO 8434-3 E SAE 52M0201

Part Number Information

EML — Body only

EMLO — Assembled with O-rings

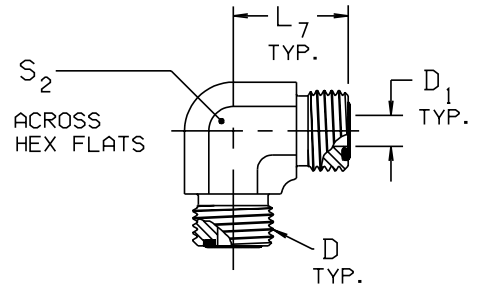

Dimensions in millimeters

TUBE FITTING PART #	TUBE O.D. (mm)	TUBE O.D. (inch)	D TUBE END UN/UNF-2A	D1 (mm)	L7 (mm)	S2 (mm)	STANDARD MATERIAL FROM STOCK		
							S	SS	B
4EMLO	6	1/4	9/16-18	5.0	21.5	14	•		
6EMLO	8, 10	3/8	11/16-16	6.5	25.0	17	•		
8EMLO	12	1/2	13/16-16	9.5	28.0	19	•		
10EMLO	14, 15, 16	5/8	1-14	12.5	33.5	27	•		
12EMLO	18, 20	3/4	1 3/16-12	15.5	37.5	27	•		
16EMLO	22, 25	1	1 7/16-12	20.5	41.5	36	•		
20EMLO	28, 30, 32	1 1/4	1 11/16-12	26.0	44.5	41	•		
24EMLO	35, 38	1 1/2	2-12	32.0	49.0	50	•		

See page I34 for information on replacement face seal O-rings.

Union Straight HMLO

ORFS tube end (both ends)

ISO 8434-3 S SAE 52M0101

Part Number Information

HML — Body only

HMLO — Assembled with O-rings

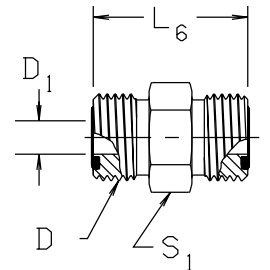

Dimensions in millimeters

TUBE FITTING PART #	TUBE O.D. (mm)	TUBE O.D. (inch)	D TUBE END UN/UNF-2A	D1 DRILL (mm)	L6 (mm)	S1 HEX (mm)	STANDARD MATERIAL FROM STOCK		
							S	SS	B
4HMLO	6	1/4	9/16-18	5.0	27.5	14	•		
6HMLO	8, 10	3/8	11/16-16	6.5	31.0	19	•		
8HMLO	12	1/2	13/16-16	9.5	35.5	22	•		
10HMLO	14, 15, 16	5/8	1-14	12.5	42.5	27	•		
12HMLO	18, 20	3/4	1 3/16-12	15.5	47.0	32	•		
16HMLO	22, 25	1	1 7/16-12	20.5	49.5	41	•		
20HMLO	28, 30, 32	1 1/4	1 11/16-12	26.0	51.5	46	•		
24HMLO	35, 38	1 1/2	2-12	32.0	53.0	55	•		

See page I34 for information on replacement face seal O-rings.

Union Tee JMLO

ORFS tube end (all three ends)

ISO 8434-3 T SAE 52M0401

Part Number Information

JML — Body only

JMLO — Assembled with O-rings

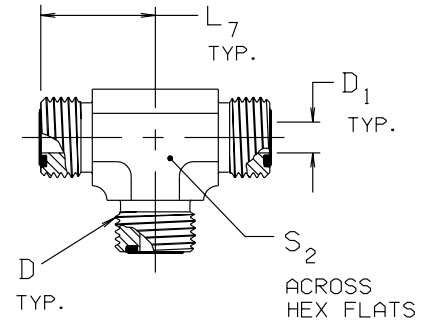

Dimensions in millimeters

TUBE FITTING PART #	TUBE O.D. (mm)	TUBE O.D. (inch)	D TUBE END UN/UNF-2A	D1 DRILL (mm)	L7 (mm)	S2 (mm)	STANDARD MATERIAL FROM STOCK		
							S	SS	B
4JMLO	6	1/4	9/16-18	5.0	21.5	14	•		
6JMLO	8, 10	3/8	11/16-16	6.5	25.0	17	•		
8JMLO	12	1/2	13/16-16	9.5	28.0	19	•		
10JMLO	14, 15, 16	5/8	1-14	12.5	33.5	27	•		
12JMLO	18, 20	3/4	1 3/16-12	15.5	37.5	27	•		
16JMLO	22, 25	1	1 7/16-12	20.5	41.5	36	•		
20JMLO	28, 30, 32	1 1/4	1 11/16-12	26.0	44.5	41	•		
24JMLO	35, 38	1 1/2	2-12	32.0	49.0	50	•		

See page I34 for information on replacement face seal O-rings.

Union Cross KMLO

ORFS tube end (all four ends)

ISO 8434-3 K SAE 52M0501

Part Number Information

KML — Body only

KMLO — Assembled with O-rings

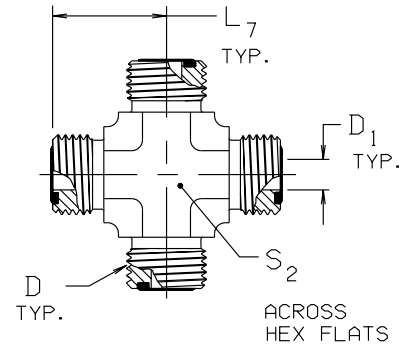

Dimensions in millimeters

TUBE FITTING PART #	TUBE O.D. (mm)	TUBE O.D. (inch)	D TUBE END UN/UNF-2A	D1 DRILL (mm)	L7 (mm)	S2 (mm)	STANDARD MATERIAL FROM STOCK		
							S	SS	B
4KMLO	6	1/4	9/16-18	5.0	21.5	14			
6KMLO	8, 10	3/8	11/16-16	6.5	25.0	17			
8KMLO	12	1/2	13/16-16	9.5	28.0	19	•		
10KMLO	14, 15, 16	5/8	1-14	12.5	33.5	27	•		
12KMLO	18, 20	3/4	1 3/16-12	15.5	37.5	27			
16KMLO	22, 25	1	1 7/16-12	20.5	41.5	36	•		
20KMLO	28, 30, 32	1 1/4	1 11/16-12	26.0	44.5	41			
24KMLO	35, 38	1 1/2	2-12	32.0	49.0	50			

See page I34 for information on replacement face seal O-rings.

Bulkhead Union Elbow

WEMLO

ORFS tube end / ORFS bulkhead tube end

ISO 8434-3 BHE SAE 52M0701

Part Number Information

WEML — Body only

WEMLO — Assembled with O-rings

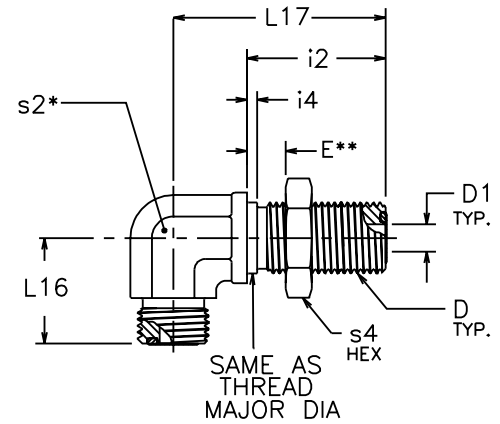

Dimensions in millimeters

TUBE FITTING PART #	TUBE O.D. (mm)	TUBE O.D. (inch)	D TUBE END UN/UNF-2A	D1 DRILL (mm)	E (mm)	I2 (mm)	I4 (mm)	L16 (mm)	L17 (mm)	S2 (mm)	S4 HEX (mm)	STANDARD MATERIAL FROM STOCK		
												S	SS	B
4WEMLO	6	1/4	9/16-18	5.0	14	31.5	1.5	22.5	47.0	14	22	•		
6WEMLO	8, 10	3/8	11/16-16	6.5	14	34.0	1.5	26.0	52.0	17	27	•		
8WEMLO	12	1/2	13/16-16	9.5	14	36.5	2.5	29.0	55.5	19	30	•		
10WEMLO	14, 15, 16	5/8	1-14	12.5	14	40.5	2.5	34.5	63.0	24	36	•		
12WEMLO	18, 20	3/4	1 3/16-12	15.5	14	41.5	3.0	38.5	67.0	27	41	•		
16WEMLO	22, 25	1	1 7/16-12	20.5	14	42.0	3.0	42.5	71.0	36	46	•		
20WEMLO	28, 30, 32	1 1/4	1 11/16-12	26.0	14	42.0	3.0	45.5	75.5	41	50	•		
24WEMLO	35, 38	1 1/2	2-12	32.0	14	42.0	3.0	49.5	79.5	50	60	•		

See page I34 for information on replacement face seal O-rings.

S2* Across wrench flats

E** Maximum bulkhead thickness

Bulkhead Run Tee

WJJMLO

ORFS tube ends / ORFS bulkhead tube end

ISO 8434-3 BHRT SAE 52M0958

Part Number Information

WJJML — Body only

WJJMLO — Assembled with O-rings

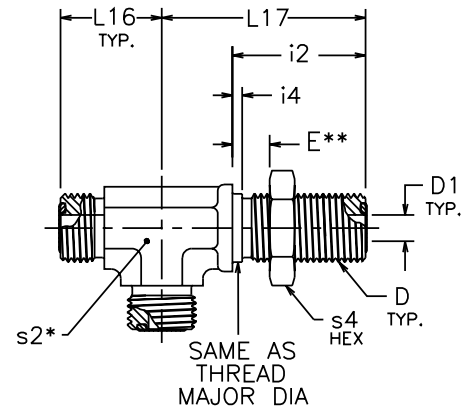

Dimensions in millimeters

TUBE FITTING PART #	TUBE O.D. (mm)	TUBE O.D. (inch)	D TUBE END UN/UNF-2A	D1 DRILL (mm)	E (mm)	I2 (mm)	I4 (mm)	L16 (mm)	L17 (mm)	S2 (mm)	S4 HEX (mm)	STANDARD MATERIAL FROM STOCK		
												S	SS	B
4WJJMLO	6	1/4	9/16-18	5.0	14	31.5	1.5	22.5	47.0	14	22	•		
6WJJMLO	8, 10	3/8	11/16-16	6.5	14	34.0	1.5	26.0	52.0	17	27	•		
8WJJMLO	12	1/2	13/16-16	9.5	14	36.5	2.5	29.0	55.5	19	30	•		
10WJJMLO	14, 15, 16	5/8	1-14	12.5	14	40.5	2.5	34.5	63.0	24	36	•		
12WJJMLO	18, 20	3/4	1 3/16-12	15.5	14	41.5	3.0	38.5	67.0	27	41	•		
16WJJMLO	22, 25	1	1 7/16-12	20.5	14	42.0	3.0	42.5	71.0	36	46	•		
20WJJMLO	28, 30, 32	1 1/4	1 11/16-12	26.0	14	42.0	3.0	45.5	75.5	41	50	•		
24WJJMLO	35, 38	1 1/2	2-12	32.0	14	42.0	3.0	49.5	79.5	50	60	•		

See page I34 for information on replacement face seal O-rings.

S2* Across wrench flats

E** Maximum bulkhead thickness

Bulkhead Union WMLO

ORFS tube end / ORFS bulkhead tube end

ISO 8434-3 BHS SAE 52M0601

Part Number Information

WML — Body only

WMLO — Assembled with O-rings

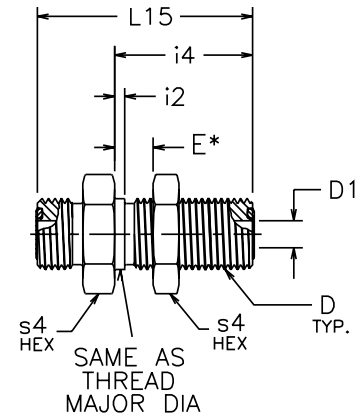

Dimensions in millimeters

TUBE FITTING PART #	TUBE O.D. (mm)	TUBE O.D. (inch)	D TUBE END UN/UNF-2A	D1 DRILL (mm)	E (mm)	I2 (mm)	I4 (mm)	L15 (mm)	S4 HEX (mm)	STANDARD MATERIAL FROM STOCK		
										S	SS	B
4WMLO	6	1/4	9/16-18	5.0	14	31.5	1.5	48.0	22	•		
6WMLO	8, 10	3/8	11/16-16	6.5	14	34.0	1.5	53.0	27	•		
8WMLO	12	1/2	13/16-16	9.5	14	36.5	2.5	58.5	30	•		
10WMLO	14, 15, 16	5/8	1-14	12.5	14	40.5	2.5	66.5	36	•		
12WMLO	20	3/4	1 3/16-12	15.5	14	41.5	3.0	69.0	41	•		
16WMLO	22, 25	1	1 7/16-12	20.5	14	42.0	3.0	70.0	46	•		
20WMLO	28, 30	1 1/4	1 11/16-12	26.0	14	42.0	3.0	70.0	50	•		
24WMLO	35, 38	1 1/2	2-12	32.0	14	42.0	3.0	70.0	60	•		

See page I34 for information on replacement face seal O-rings.

E* Maximum bulkhead thickness

45° Bulkhead Union Elbow WNMLO

ORFS tube end / ORFS bulkhead tube end

ISO 8434-3 BHE45 SAE 52M0801

Part Number Information

WNML — Body only

WNMLO — Assembled with O-rings

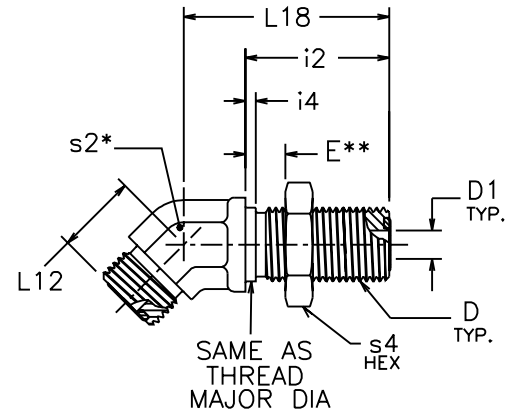

Dimensions in millimeters

TUBE FITTING PART #	TUBE O.D. (mm)	TUBE O.D. (inch)	D TUBE END UN/UNF-2A	D1 DRILL (mm)	E (mm)	I2 (mm)	I4 (mm)	L12 (mm)	L18 (mm)	S2 (mm)	S4 HEX (mm)	STANDARD MATERIAL FROM STOCK		
												S	SS	B
4WNMLO	6	1/4	9/16-18	5.0	14	31.5	1.5	16.0	44.0	14	22	•		
6WNMLO	8, 10	3/8	11/16-16	6.5	14	34.0	1.5	19.0	48.5	17	27	•		
8WNMLO	12	1/2	13/16-16	9.5	14	36.5	2.5	20.5	51.0	19	30	•		
10WNMLO	14, 15, 16	5/8	1-14	12.5	14	40.5	2.5	23.5	56.5	24	36	•		
12WNMLO	18, 20	3/4	1 3/16-12	15.5	14	41.5	3.0	26.0	60.5	27	41	•		
16WNMLO	22, 25	1	1 7/16-12	20.5	14	42.0	3.0	30.0	65.0	36	46	•		
20WNMLO	28, 30, 32	1 1/4	1 11/16-12	26.0	14	42.0	3.0	32.0	67.0	41	50	•		
24WNMLO	35, 38	1 1/2	2-12	32.0	14	42.0	3.0	37.0	67.0	50	60	•		

See page I34 for information on replacement face seal O-rings.

S2* Across wrench flats.

E** Maximum bulkhead thickness.

Bulkhead Branch Tee

WJMLO

ORFS tube ends / ORFS bulkhead tube end

ISO 8434-3 BHBT SAE 52M0959

Part Number Information

WJML — Body only

WJMLO — Assembled with O-rings

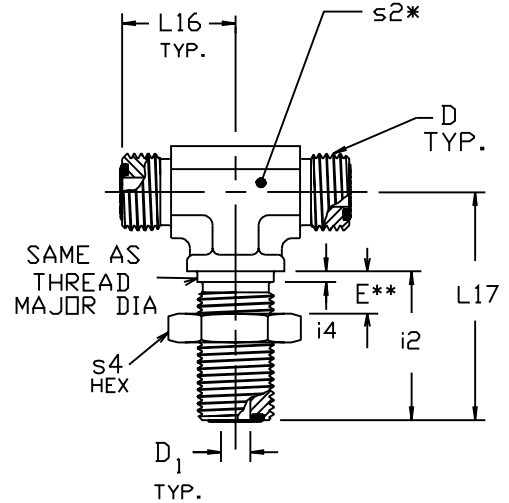

Dimensions in millimeters

TUBE FITTING PART #	TUBE O.D. (mm)	TUBE O.D. (inch)	D TUBE END UN/UNF-2A	D1 DRILL (mm)	E (mm)	i2 (mm)	i4 (mm)	L16 (mm)	L17 (mm)	S2 (mm)	S4 HEX (mm)	STANDARD MATERIAL FROM STOCK		
												S	SS	B
4WJMLO	6	1/4	9/16-18	5.0	14	31.5	1.5	22.5	47.0	14	22	•		
6WJMLO	8, 10	3/8	11/16-16	6.5	14	34.0	1.5	26.0	52.0	17	27	•		
8WJMLO	12	1/2	13/16-16	9.5	14	36.5	2.5	29.0	55.5	19	30	•		
10WJMLO	14, 15, 16	5/8	1-14	12.5	14	40.5	2.5	34.5	63.0	24	36	•		
12WJMLO	18, 20	3/4	1 3/16-12	15.5	14	41.5	3.0	38.5	67.0	27	41	•		
16WJMLO	22, 25	1	1 7/16-12	20.5	14	42.0	3.0	42.5	71.0	36	46	•		
20WJMLO	28, 30, 32	1 1/4	1 11/16-12	26.0	14	42.0	3.0	45.5	75.5	41	50			
24WJMLO	35, 38	1 1/2	2-12	32.0	14	42.0	3.0	49.5	79.5	50	60			

See page I34 for information on replacement face seal O-rings.

S2* Across wrench flats.

E** Maximum bulkhead thickness.

Tube Nut

BML

ORFS tube end nut

ISO 8434-3 NA SAE 52M0110A

Part Number Information

BML — Nut with metric hex

Dimensions in millimeters

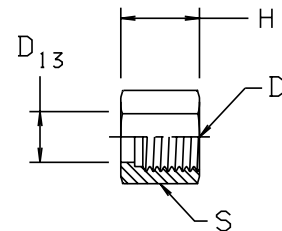

TUBE FITTING PART #	TUBE O.D. (mm)	TUBE O.D. (inch)	D THREAD UN/UNF-2B	D13 DRILL (mm)	H (mm)	S HEX (mm)	STANDARD MATERIAL FROM STOCK		
							S	SS	B
4BML	6	1/4	9/16-18	10.50	15.0	17	•		
6BML	8, 10	3/8	11/16-16	13.55	17.0	22	•		
8BML	12	1/2	13/16-16	16.60	20.0	24	•		
10BML	14, 15, 16	5/8	1-14	21.10	24.0	30	•		
12BML	18, 20	3/4	1 3/16-12	24.15	26.5	36	•		
16BML	22, 25	1	1 7/16-12	29.10	27.5	41	•		
20BML	28, 30, 32	1 1/4	1 11/16-12	36.00	27.5	50	•		
24BML	35, 38	1 1/2	2-12	44.00	27.5	60	•		

MMLOHB3

ORFS tube end / silver braze socket*

ISO 8434-3 BRS SAE 52M0104

Part Number Information

MMLHB3 — Body only

MMLOHB3 — Assembled with O-ring

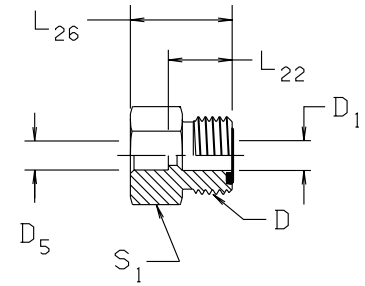

Dimensions in millimeters

TUBE FITTING PART #	ORFS Tube O.D.		Socket Braze Tube O.D. (mm)	D5 DIA TUBE SOCKET	D UN/UNF-2A	D1 DRILL	L22	L26	S1 HEX	STANDARD MATERIAL FROM STOCK		
	(inch)	(mm)								S	SS	B
4-6MMLOHB3	1/4	6	6	6.15	9/16-18	5.0	13.5	22.0	17			
4-8MMLOHB3	1/4	6	8	8.15	9/16-18	5.0	13.5	22.0	17			
6-10MMLOHB3	3/8	8, 10	10	10.15	11/16-16	6.5	14.5	23.0	19			
8-12MMLOHB3	1/2	12	12	12.15	13/16-16	9.5	16.0	24.5	22			
10-16MMLOHB3	5/8	14, 15, 16	16	16.15	1-14	12.5	19.0	27.5	27			
12-20MMLOHB3	3/4	18, 20	20	20.18	1 3/16-12	15.5	21.0	33.5	32			
16-25MMLOHB3	1	22, 25	25	25.18	1 7/16-12	20.5	24.5	38.5	41			
20-30MMLOHB3	1 1/4	28, 30, 32	30	30.20	1 11/16-12	26.0	24.5	38.5	46			
24-38MMLOHB3	1 1/2	35, 38	38	38.20	2-12	32.0	24.5	38.5	55			

See page I34 for information on replacement face seal O-rings.

Unplated part, oil dipped for corrosion protection.

*D5 is for silver brazing. Standard steel parts are not recommended for welding.

NOTE: If ordered with O-ring assembled, the O-ring must be removed prior to brazing operation.

Plug PNMLO

ORFS tube end plug

ISO 8434-3 PL SAE 52M0109

Part Number Information

PNML — Body only

PNMLO — Assembled with O-ring

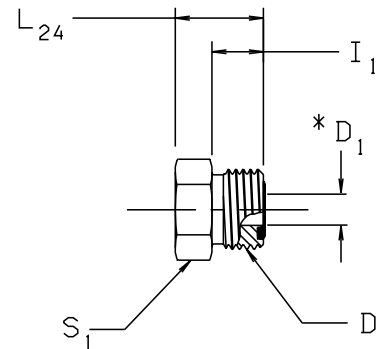

Dimensions in millimeters

TUBE FITTING PART #	ORFS Tube O.D.		D TUBE END UN/UNF-2A	D1 DRILL (mm)	I1 (mm)	L24 (mm)	S1 HEX (mm)	STANDARD MATERIAL FROM STOCK		
	(inch)	(mm)						S	SS	B
4PNMLO	1/4	6	9/16-18	5.0	10.0	16.5	17	•		
6PNMLO	3/8	8, 10	11/16-16	6.5	11.0	19.0	19	•		
8PNMLO	1/2	12	13/16-16	9.5	13.0	22.0	22	•		
10PNMLO	5/8	14, 15, 16	1-14	12.5	15.5	26.0	27	•		
12PNMLO	3/4	18, 20	1 3/16-12	15.5	17.0	27.5	32	•		
16PNMLO	1	22, 25	1 7/16-12	20.5	17.5	28.0	41	•		
20PNMLO	1 1/4	28, 30, 32	1 11/16-12	26.0	17.5	28.0	46	•		
24PNMLO	1 1/2	35, 38	2-12	32.0	17.5	28.0	55	•		

See page I34 for information on replacement face seal O-rings.

*D1 drill is optional at manufacturer's discretion.

Braze Sleeve For Metric Tubing

TL

ORFS Silver Braze Sleeve
ISO 8434-3 BRSL SAE 5201M15

Part Number Information

TLS6 — Steel braze sleeve for 6mm tubing

TLSS6 — Stainless steel braze sleeve for 6mm tubing

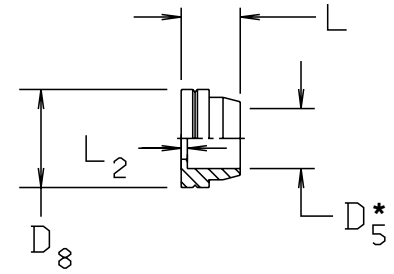

** D5 is for silver braze.

Size after part number indicates metric.

Dimensions in millimeters

(1) TUBE FITTING PART #	USED WITH FITTING SIZE	D5 TUBE O.D. (mm)	D8 DIA (mm)	L (mm)	L2 (mm)	STANDARD MATERIAL FROM STOCK		
						S	SS	B
TLS6	-4	6	12.8	9.5	1.0	•	•	
TLS8	-6	8	15.8	9.5	1.0	•	•	
TLS10	-6	10	15.8	9.5	1.0	•		
TLS12	-8	12	18.9	9.5	1.0	•	•	
TLS16	-10	16	23.5	10.5	1.5	•	•	
TLS20	-12	20	27.9	14.0	1.5	•	•	
TLS25	-16	25	34.2	15.5	1.5	•	•	
TLS30	-20	30	40.6	15.5	1.5	•	•	
TLS38	-24	38	48.5	15.5	1.5	•	•	

(1) See part number information above.

Parflange Sleeve For Metric Tubing

TPL

ORFS Mechanically Attachable Sleeve

Part Number Information

TPLS6 — Steel Parflange sleeve for 6mm tubing

TPSS6 — Stainless steel Parflange sleeve for 6mm tubing

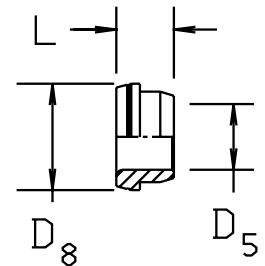

Dimensions in millimeters

(1) TUBE FITTING PART #	USED WITH FITTING SIZE	D5 TUBE O.D. (mm)	D8 DIA (mm)	L (mm)	STANDARD MATERIAL FROM STOCK		
					S	SS	B
TPLS6	-4	6	13.0	7.5	•		
TPLS8	-6	8	16.0	8.5	•		
TPLS10	-6	10	16.0	8.5	•		
TPLS12	-8	12	19.0	10.5	•		
TPLS14	-10	14	21.0	10.5	•		
TPLS15	-10	15	23.5	10.5	•		
TPLS16	-10	16	23.5	10.5	•		
TPLS18	-12	18	28.0	12.0	•		
TPLS20	-12	20	28.0	12.0	•		
TPLS22	-16	22	34.0	13.5	•		
TPLS25	-16	25	34.0	13.5	•		
TPLS28	-20	28	40.5	13.0	•		
TPLS30	-20	30	40.5	13.0	•		
TPLS32	-20	32	40.5	13.0	•		
TPLS35	-24	35	48.5	12.5	•		
TPLS38	-24	38	48.5	12.5	•		

(1) See part number information above.

Bulkhead Locknut WLNML

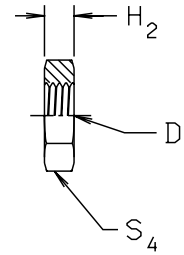

Bulkhead fitting locknut

ISO 8434-3 BHLN SAE 52M0118

Part Number Information
WLNML — Body only

Dimensions in millimeters

TUBE FITTING PART #	TUBE O.D. (mm)	TUBE O.D. (inch)	D TUBE END UN/UNF-2B	H2 (mm)	S4 HEX (mm)	STANDARD MATERIAL FROM STOCK		
						S	SS	B
4WLNML	6	1/4	9/16-18	7.0	22	•		
6WLNML	8, 10	5/16 & 3/8	11/16-16	8.0	27	•		
8WLNML	12	1/2	13/16-16	9.0	30	•		
10WLNML	14, 15, 16	5/8	1-14	10.5	36	•		
12WLNML	18, 20	3/4	1 3/16-12	10.5	41	•		
16WLNML	22, 25	1	1 7/16-12	10.5	46	•		
20WLNML	28, 30, 32	1 1/4	1 11/16-12	10.5	50	•		
24WLNML	35, 38	1 1/2	2-12	10.5	60	•		

ORFS Tube End Face Seal O-Ring

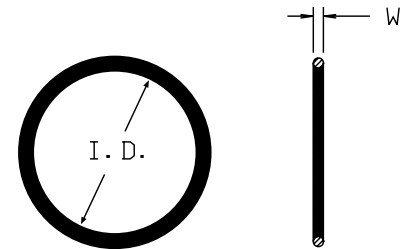

Part Number Information
Specify size and compound
Example: 2-018 N0756

Dimensions in millimeters

TUBE FITTING SIZE	O-RING PART #	TUBE O.D. (mm)	ID (mm)	W (mm)	STANDARD MATERIAL FROM STOCK		
					N0552	V0894	N0756
4	2-011	6	7.7	1.78	•	•	•
6	2-012	8, 10	9.3	1.78	•	•	•
8	2-014	12	12.4	1.78	•	•	•
10	2-016	14, 15, 16	15.6	1.78	•	•	
12	2-018	18, 20	18.8	1.78	•	•	
16	2-021	22, 25	23.5	1.78	•	•	
20	2-025	28, 30, 32	29.9	1.78	•	•	
24	2-029	35, 38	37.8	1.78	•	•	

N0552 is the standard 90-durometer Nitrile (e.g., Buna-N).
V0894 is an optional 90-durometer fluorocarbon (e.g., Viton).
N0756 is an optional 75-durometer Nitrile (e.g., Buna-N) for CNG applications.
Other compounds may be purchased from the Parker O-ring Division, phone (606) 269-2351.
[See page A29](#) for O-ring Material Selection and data.

Metric Straight Thread Port O-Ring

ISO 6149 O-Ring

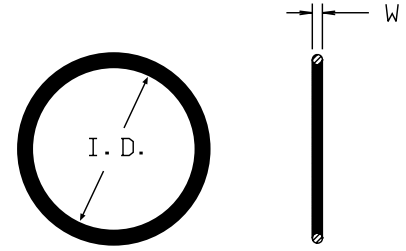

Part Number Information

Specify size and compound

Example: M12 ISO O-RING (For standard 90 durometer peroxide-cured Nitrile O-ring)
M12 ISO FKM O-RING (FKM)

Dimensions in millimeters

O-RING PART #	PORT THREAD	ID (mm)	W (mm)	STANDARD MATERIAL FROM STOCK	
				NBR	FKM
M8 ISO O-Ring	M8X1	6.1	1.6	•	
M10 ISO O-Ring	M10X1	8.1	1.6	•	
M12 ISO O-Ring	M12X1.5	9.3	2.2	•	•
M14 ISO O-Ring	M14X1.5	11.3	2.2	•	•
M16 ISO O-Ring	M16X1.5	13.3	2.2	•	•
M18 ISO O-Ring	M18X1.5	15.3	2.2	•	•
M22 ISO O-Ring	M22X1.5	19.3	2.2	•	•
M27 ISO O-Ring	M27X1.5	23.6	2.9	•	•
M30 ISO O-Ring	M30X2	26.6	2.9	•	
M33 ISO O-Ring	M33X1.5	29.6	2.9	•	•
M38 ISO O-Ring	M38X2	34.6	2.9	•	
M42 ISO O-Ring	M42X2	38.6	2.9	•	•
M48 ISO O-Ring	M48X2	44.6	2.9	•	•
M60 ISO O-Ring	M60X2	56.6	2.9	•	

*M30X2 is not a standard ISO 6149 size.

NBR is the standard 90-durometer peroxide-cured Nitrile (e.g., Buna-N).

FKM is an optional 90-durometer fluoroelastomer (e.g., Viton).

[See page A29](#) for O-ring Material Selection and data.



Silver Braze Ring for Metric Tubing

SBR

Part Number Information

Specify size and tube material

Example: SBR14 (Braze ring for 14mm steel or copper tubing)
SBRSS14 (Braze ring for 14mm stainless steel tubing)

Dimensions in millimeters

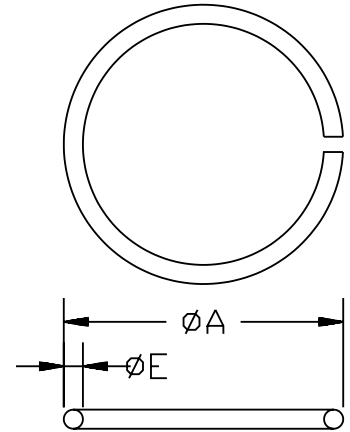

BRAZE RING PART #	TUBE O.D. (mm)	A DIA (mm)	E (mm)	STANDARD MATERIAL FROM STOCK		
				S	SS	B
SBR6	6	6.4	1.2	•	•	
SBR8	8	8.4	1.2	•	•	
SBR10	10	10.4	1.2	•	•	
SBR12	12	12.4	1.2	•	•	
SBR14	14	14.4	1.2	•	•	
SBR15	15	15.4	1.2	•	•	
SBR16	16	16.4	1.2	•	•	
SBR18	18	18.4	1.2	•	•	
SBR20	20	20.4	1.6	•	•	
SBR22	22	22.4	1.6	•	•	
SBR25	25	25.4	1.6	•	•	
SBR28	28	28.4	1.6	•	•	
SBR30	30	30.4	1.6	•	•	
SBR32	32	32.4	1.6	•	•	
SBR35	35	35.4	1.6	•		
SBR38	38	38.4	1.6	•	•	
SBR42	42	42.4	1.6	•		

SBR recommended for steel or copper tubing.
SBRSS is recommended for stainless tubing but can be used on steel tubing.

[Contact the Tube Fittings Division](#) for braze rings used in marine applications.

Male Elbow – BSPP (for ISO 1179-1 Port)

C4OMLO

ORFS tube end / Male BSPP port end

Part Number Information
C4ML - Body only
C4OMLO - Assembled with O-rings and retaining ring

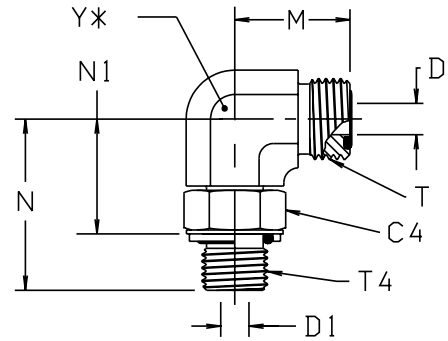

*Y — ACROSS WRENCH FLATS

Dimensions in millimeters

TUBE FITTING PART #	TUBE O.D. (mm)	TUBE O.D. (inch)	T TUBE END UN/UNF-2A	T4 PORT THD BSPP	C4 HEX (mm)	D DRILL (mm)	D1 DRILL (mm)	M (mm)	N (mm)	N1 (mm)	Y (mm)	STANDARD MATERIAL FROM STOCK		
												S	SS	B
4C4OMLO	6	1/4	9/16-18	1/8-28	14	4.5	4.5	21.5	30.0	22.0	14	•		
4-4C4OMLO	6	1/4	9/16-18	1/4-19	19	4.5	7.5	23.5	36.0	24.5	19	•		
4-6 C4OMLO	6	1/4	9/16-18	3/8-19	22	4.5	10.0	24.5	38.0	27.0	19	•		
6C4OMLO	8, 10	3/8	11/16-16	1/4-19	19	6.5	7.5	25.0	36.0	24.5	19	•		
6-6C4OMLO	8, 10	3/8	11/16-16	3/8-19	22	6.5	10.0	26.5	38.0	27.0	19	•		
8-4 C4OMLO	12	1/2	13/16-16	1/4-19	19	9.5	7.5	28.0	35.5	24.5	19	•		
8C4OMLO	12	1/2	13/16-16	3/8-19	22	9.5	10.0	28.0	38.0	27.0	19	•		
8-8C4OMLO	12	1/2	13/16-16	1/2-14	27	9.5	12.5	31.0	48.5	34.0	27	•		
8-12 C4OMLO	12	1/2	13/16-16	3/4-14	36	9.5	15.5	33.5	51.5	36.5	30	•		
10-6 C4OMLO	14, 15, 16	5/8	1-14	3/8-19	22	12.5	10.0	33.5	40.5	29.5	27	•		
10C4OMLO	14, 15, 16	5/8	1-14	1/2-14	27	12.5	12.5	33.5	48.5	34.0	27	•		
10-12C4OMLO	14, 15, 16	5/8	1-14	3/4-14	36	12.5	15.5	36.0	51.5	36.5	30	•		
10-16 C4OMLO	14, 15, 16	5/8	1-14	1-11	41	12.5	21.5	39.5	58.5	41.5	37	•		
12-8 C4OMLO	18, 20	3/4	1 3/16-12	1/2-14	27	15.5	12.5	37.5	49.5	34.5	37	•		
12C4OMLO	18, 20	3/4	1 3/16-12	3/4-14	36	15.5	15.5	37.5	51.5	36.5	30	•		
12-16 C4OMLO	18, 20	3/4	1 3/16-12	1-11	41	15.5	21.5	41.0	58.5	41.5	37	•		
16-12C4OMLO	22, 25	1	1 7/16-12	3/4-14	36	20.5	15.5	41.5	56.0	41.0	37	•		
16C4OMLO	22, 25	1	1 7/16-12	1-11	41	20.5	21.5	41.5	58.5	41.5	37	•		
16-20 C4OMLO	22, 25	1	1 7/16-12	1 1/4-11	50	20.5	27.5	44.5	61.0	44.0	41	•		
20-16C4OMLO	28, 30, 32	1 1/4	1 11/16-12	1-11	41	26.0	21.5	44.5	61.0	44.0	41	•		
20 C4OMLO	28, 30, 32	1 1/4	1 11/16-12	1 1/4-11	50	26.0	27.5	44.5	61.0	44.0	41	•		
20-24C4OMLO	28, 30, 32	1 1/4	1 11/16-12	1 1/2-11	55	26.0	33.0	49.0	64.5	47.5	50	•		
24C4OMLO	35, 38	1 1/2	2-12	1 1/2-11	55	32.0	33.0	49.0	64.5	47.5	50	•		

Face Seal O-ring information is on [page I34](#).
O-ring and retaining ring parts information is on [page I63](#).

Male Connector – BSPP (for ISO 1179-1 Port)

F42EDMLO

ORFS tube end / Male BSPP port end with Eolastic Seal

Part Number Information
F42EDMLO - Body with EOlastic “ED” Seal

Dimensions in millimeters

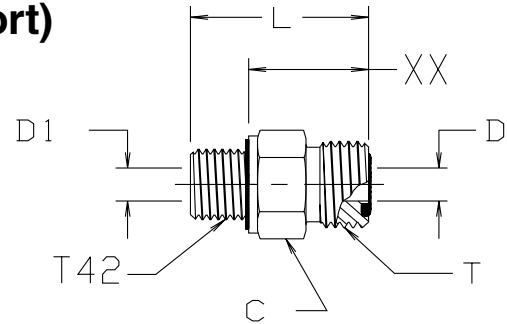

TUBE FITTING PART #	TUBE O.D. (mm)	TUBE O.D. (inch)	T TUBE END UN/UNF-2A	T42 PORT THD BSPP	C HEX (mm)	D DRILL (mm)	D1 DRILL (mm)	L (mm)	XX (mm)	STANDARD MATERIAL FROM STOCK		
										S	SS	B
4F42EDMLO	6	1/4	9/16-18	1/8 - 28	17	4.4	4.0	25.7	17.7	•		
4-4F42EDMLO	6	1/4	9/16-18	1/4 - 19	19	4.4	4.4	30.9	18.9	•		
4-6F42EDMLO	6	1/4	9/16-18	3/8 - 19	22	4.4	4.4	31.6	19.6			
4-8F42EDMLO	6	1/4	9/16-18	1/2 - 14	27	4.4	4.4	38.4	24.4			
6-2F42EDMLO	8, 10	3/8	11/16-16	1/8 - 28	19	6.7	4.0	31.1	23.1			
6F42EDMLO	8, 10	3/8	11/16-16	1/4 - 19	19	6.7	6.7	31.9	19.9	•		
6-6F42EDMLO	8, 10	3/8	11/16-16	3/8 - 19	22	6.7	6.7	33.5	21.5	•		
6-8F42EDMLO	8, 10	3/8	11/16-16	1/2 - 14	27	6.7	6.7	38.5	24.5			
6-12F42EDMLO	8, 10	3/8	11/16-16	3/4 - 14	32	6.7	6.7	40.3	24.3			
8-4F42EDMLO	12	1/2	13/16-16	1/4 - 19	22	9.6	7.0	36.7	24.7			
8F42EDMLO	12	1/2	13/16-16	3/8 - 19	22	9.6	8.0	34.6	22.6	•		
8-8F42EDMLO	12	1/2	13/16-16	1/2 - 14	27	9.6	9.6	40.1	26.1	•		
8-12F42EDMLO	12	1/2	13/16-16	3/4 - 14	32	9.6	9.6	41.9	25.9			
10-6F42EDMLO	14, 15, 16	5/8	1-14	3/8 - 19	27	12.3	8.0	42.4	30.4			
10F42EDMLO	14, 15, 16	5/8	1-14	1/2 - 14	27	12.3	12.3	41.1	27.1	•		
10-12F42EDMLO	14, 15, 16	5/8	1-14	3/4 - 14	32	12.3	12.3	44.3	28.3			
10-16F42EDMLO	14, 15, 16	5/8	1-14	1 - 11	41	12.3	12.3	47.8	29.8			
12-8F42EDMLO	18, 20	3/4	1 3/16-12	1/2 - 14	32	15.5	12.0	48.5	24.5	•		
12F42EDMLO	18, 20	3/4	1 3/16-12	3/4 - 14	32	15.5	15.5	46.1	30.1	•		
12-16F42EDMLO	18, 20	3/4	1 3/16-12	1 - 11	41	15.5	15.5	47.5	29.6			
12-20F42EDMLO	18, 19, 20	3/4	1 3/16-12	1 1/4 - 11	50	15.5	15.5	53.5	33.3			
16-12F42EDMLO	22, 25	1	1 7/16-12	3/4 - 14	38	20.6	16.0	50.3	34.3			
16F42EDMLO	22, 25	1	1 7/16-12	1 - 11	41	20.6	20.0	49.8	31.8	•		
16-20F42EDMLO	22, 25	1	1 7/16-12	1 1/4 - 11	50	20.6	20.6	53.8	33.8			
16-24F42EDMLO	22, 25	1	1 7/16-12	1 1/2 - 11	55	20.6	20.6	57.5	35.6			
20-16F42EDMLO	28, 30, 32	1 1/4	1 11/16-12	1 - 11	48	26.0	20.0	57.3	39.3			
20F42EDMLO	28, 30, 32	1 1/4	1 11/16-12	1 1/4 - 11	50	26.0	25.0	53.8	33.8	•		
20-24F42EDMLO	28, 30, 32	1 1/4	1 11/16-12	1 1/2 - 11	55	26.0	26.0	57.6	35.6			
24F42EDMLO	35, 38	1 1/2	2-12	1 1/2 - 11	55	32.0	32.0	57.6	35.6	•		

See page H123 for information on replacement “ED” seal rings.

Face Seal O-ring information is on page I34.

*Manufacturing option permits a single drill through equal to the smaller of D and D1.

Run Tee – BSPP (for ISO 1179-1 Port)

R4OMLO

ORFS tube end / Male BSPP port end

Part Number Information
R4ML - Body only
R4OMLO - Assembled with O-rings and retaining ring

Dimensions in millimeters

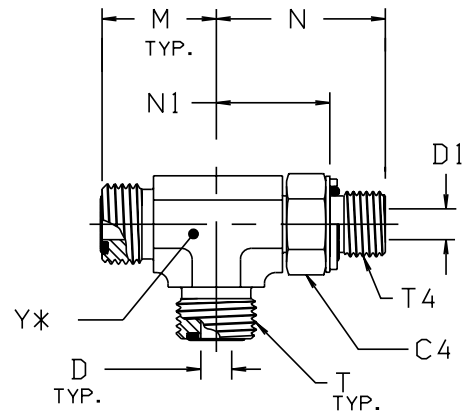

*Y — ACROSS WRENCH FLATS

TUBE FITTING PART #	TUBE O.D. (mm)	TUBE O.D. (inch)	T TUBE END UN/UNF-2A	T4 PORT THD BSPP	C4 HEX (mm)	D DRILL (mm)	D1 DRILL (mm)	M (mm)	N (mm)	N1 (mm)	Y (mm)	STANDARD MATERIAL FROM STOCK		
												S	SS	B
4R4OMLO	6	1/4	9/16-18	1/8 - 28	14	4.5	4.5	21.5	30.0	22.0	14			
4-4-4R4OMLO	6	1/4	9/16-18	1/4 - 19	19	4.5	7.5	23.5	36.0	24.5	19			
6R4OMLO	8, 10	3/8	11/16-16	1/4 - 19	19	6.5	7.5	25.0	36.0	24.5	19			
6-6-6R4OMLO	8, 10	3/8	11/16-16	3/8 - 19	22	6.5	10.0	26.5	38.0	27.0	19			
8R4OMLO	12	1/2	13/16-16	3/8 - 19	22	9.5	10.0	28.0	38.0	27.0	19			
8-8-8R4OMLO	12	1/2	13/16-16	1/2 - 14	27	9.5	12.5	31.0	48.5	34.0	27			
10R4OMLO	14, 15, 16	5/8	1-14	1/2 - 14	27	12.5	12.5	33.5	48.5	34.0	27			
10-12-10R4OMLO	14, 15, 16	5/8	1-14	3/4 - 14	36	12.5	15.5	36.0	51.5	36.5	30			
12R4OMLO	18, 20	3/4	1 3/16-12	3/4 - 14	36	15.5	15.5	37.5	51.5	36.5	30			
12-16-12R4OMLO	18, 20	3/4	1 3/16-12	1 - 11	41	15.5	21.5	41.0	58.5	41.5	37			
16R4OMLO	22, 25	1	1 7/16-12	1 - 11	41	20.5	21.5	41.5	58.5	41.5	37			

Face Seal O-ring information is on [page I34](#).
O-ring and retaining ring parts information is on [page I63](#).

Branch Tee – BSPP (for ISO 1179-1 Port)

S4OMLO

ORFS tube end / Male BSPP port end

Part Number Information
S4ML - Body only
S4OMLO - Assembled with O-rings and retaining ring

Dimensions in millimeters

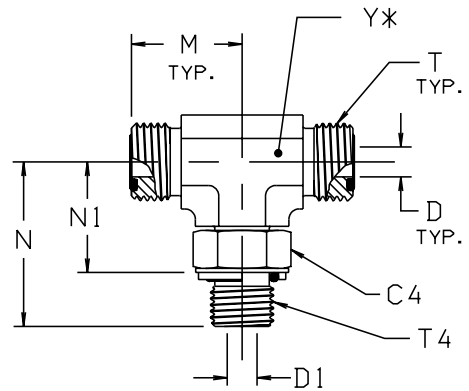

TUBE FITTING PART #	TUBE O.D. (mm)	TUBE O.D. (inch)	T TUBE END UN/UNF-2A	T4 PORT THD UN/UNF-2A	C4 HEX (mm)	D DRILL (mm)	D1 DRILL (mm)	M (mm)	N (mm)	N1 (mm)	Y (mm)	STANDARD MATERIAL FROM STOCK		
												S	SS	B
4S4OMLO	6	1/4	9/16 - 18	1/8 - 28	14	4.5	4.5	21.5	30.0	22.0	14			
4-4-4S4OMLO	6	1/4	9/16 - 18	1/4 - 19	19	4.5	7.5	23.5	36.0	24.5	19			
6S4OMLO	8, 10	3/8	11/16 - 16	1/4 - 19	19	6.5	7.5	25.0	36.0	24.5	19			
6-6-6S4OMLO	8, 10	3/8	11/16 - 16	3/8 - 19	22	6.5	10.0	26.5	38.0	27.0	19			
8S4OMLO	12	1/2	13/16 - 16	3/8 - 19	22	9.5	10.0	28.0	38.0	27.0	19			
8-8-8S4OMLO	12	1/2	13/16 - 16	1/2 - 14	27	9.5	12.5	31.0	48.5	34.0	27			
10S4OMLO	14, 15, 16	5/8	1 - 14	1/2 - 14	27	12.5	12.5	33.5	48.5	34.0	27			
10-10-12S4OMLO	14, 15, 16	5/8	1 - 14	3/4 - 14	36	12.5	15.5	36.0	51.5	36.5	30			
12S4OMLO	18, 20	3/4	1 3/16-12	3/4 - 14	36	15.5	15.5	37.5	51.5	36.5	30			

Face Seal O-ring information is on [page I34](#).
O-ring and retaining ring parts information is on [page I63](#).

Male 45° Elbow – BSPP (for ISO 1179-1 Port)

V4OMLO

ORFS tube end / Male BSPP port end

Part Number Information

V4ML - Body only

V4OMLO - Assembled with O-rings and retaining ring

Dimensions in millimeters

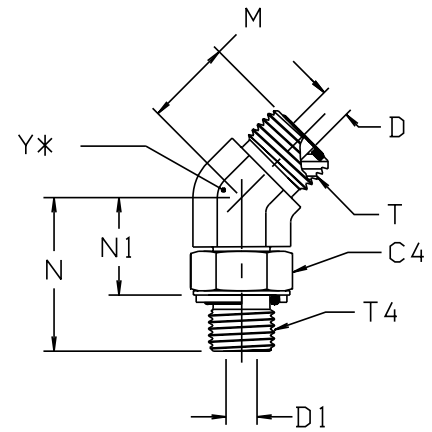

*Y — ACROSS HEX FLATS

TUBE FITTING PART #	TUBE O.D. (mm)	TUBE O.D. (inch)	T TUBE END UN/UNF-2A	T4 PORT THD BSPP	C4 HEX (mm)	D DRILL (mm)	D1 DRILL (mm)	M (mm)	N (mm)	N1 (mm)	Y (mm)	STANDARD MATERIAL FROM STOCK		
												S	SS	B
4V4OMLOS	6	1/4	9/16-18	1/8 - 28	14	4.5	4.5	16.0	27.5	19.0	14			
4-4V4OMLOS	6	1/4	9/16-18	1/4 - 19	19	4.5	7.5	17.5	32.0	21.0	19			
6V4OMLOS	8, 10	3/8	11/16-16	1/4 - 19	19	6.5	7.5	19.0	32.0	21.0	19			
6-6V4OMLOS	8, 10	3/8	11/16-16	3/8 - 19	22	6.5	10.0	19.0	33.5	22.5	19			
6-8V4OMLOS	8, 10	3/8	11/16-16	1/2 - 14	27	6.5	12.5	19.5	43.5	28.5	27			
8V4OMLOS	12	1/2	13/16-16	3/8 - 19	22	9.5	10.0	20.5	33.5	22.5	19			
10V4OMLOS	14, 15, 16	5/8	1-14	1/2 - 14	27	12.5	12.5	23.5	43.5	28.5	27			
10-12V4OMLOS	14, 15, 16	5/8	1-14	3/4 - 14	36	12.5	15.5	24.5	46.5	31.5	30			
12V4OMLOS	18, 20	3/4	1 3/16-12	3/4 - 14	36	15.5	15.5	26.0	46.5	31.5	30			
12-16V4OMLOS	18, 20	3/4	1 3/16-12	1 - 11	41	15.5	21.5	26.0	51.0	34.0	37			
16V4OMLOS	22, 25	1	1 7/16-12	1 - 11	41	20.5	21.5	30.0	51.0	34.0	37			

Face Seal O-ring information is on [page I34](#).

O-ring and retaining ring parts information is on [page I63](#).

Male Connector – Metric (for ISO 9974-1/DIN 3852-1 Port)

F82EDMLO

ORFS tube end / Male metric port end with EOlastic seal

Part Number Information

F82EDMLO - Body with EOlastic "ED" Seal

Dimensions in millimeters

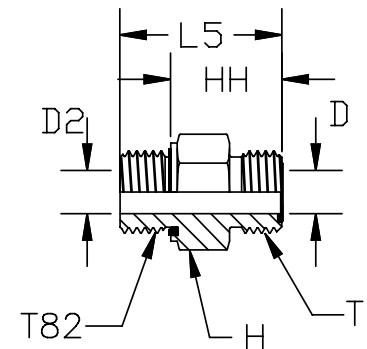

TUBE FITTING PART #	TUBE O.D. (mm)	TUBE O.D. (inch)	T TUBE END UN/UNF-2A	T82 METRIC MALE THREAD	C HEX (mm)	D DRILL (mm)	D2 DRILL (mm)	HH (mm)	L5 (mm)	STANDARD MATERIAL FROM STOCK		
										S	SS	B
4M12F82EDMLO	6	1/4	9/16-18	M12X1.5	17	5.0	4.0	17.7	29.7	•		
6M14F82EDMLO	8	3/8	11/16-16	M14X1.5	22	6.5	5.0	19.9	31.9	•		
8M18F82EDMLO	12	1/2	13/16-16	M18X1.5	24	9.5	8.0	22.6	34.6	•		
10M22F82EDMLO	14, 15, 16	5/8	1-14	M22X1.5	27	12.5	12.5	27.1	41.1	•		
12M27F82EDMLO	18, 20	3/4	1 3/16-12	M27X2	32	15.5	15.5	30.1	46.1	•		
16M33F82EDMLO	22, 25	1	1 7/16-12	M33X2	41	20.5	20.5	31.8	49.8	•		
20M42F82EDMLO	28, 30, 32	1 1/4	1 11/16-12	M42X2	50	26.0	25.0	33.8	53.8	•		

See page H123 for information on replacement "ED" seal rings.

Face Seal O-ring information is on [page I34](#).

Metric Triple-Lok 37° Flared Fittings

The 37° flared fitting is the most widely used fitting throughout the world. Because the fitting can be used to connect to inch tubing, metric tubing and also a hose assembly, this versatility offers customers a greater international acceptance as compared to other fitting styles. Parker invented this fitting in the 1920's calling it Triple-Lok. With standardization committee efforts and the proliferation of other fitting manufacturers, the 37° fitting became the most popular fitting in the world. Parker has retained the name Triple-Lok and uses it today to describe our line of 37° fittings.

The Metric Triple-Lok Section is the second of two Triple Lok sections in this catalog. Triple-Lok fittings within the [Triple-Lok Section \(section C\)](#) are offered as an ideal solution for customers utilizing inch or metric tubing with NPT or SAE Straight Thread ports in their system components. Triple-Lok fittings within the Metric/ BSP Fittings and Conversion Adapters Section are offered as an ideal solution for customers utilizing inch or metric tubing but with British, Metric or ISO-6149 ports in their system components. The flared end (tube/hose end) of the 37° flare fittings in both sections of this catalog is identical.

The 37° flared fitting is quite popular throughout the world for use with inch and metric tubing. This fitting is a three-piece design, while the mating tubing is flared to 37° angle and seats on the nose of the fitting as shown in [Fig. I11](#).

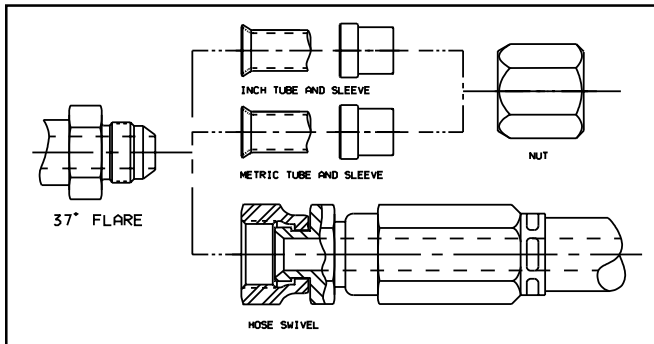

Figure I11 — 37° Flared Fittings

As shown in [Fig. I11](#), a single 37° fitting body will accept both inch and metric tubing by simply changing the sleeve. Also, the 37° body without the nut and sleeve is also very popular as a hose adapter. Study the following example illustrating the options with a 1/2" Triple-Lok fitting:

1. Fitting used with a 1/2" sleeve and 1/2" nut, it can connect to a 1/2" tubing.
2. Fitting used with a 12 mm sleeve and 1/2" nut, it can connect to 12 mm tubing.
3. Fitting used without a nut and sleeve, it can be used as a 1/2" hose adapter.

[Table I8](#) illustrates an even clearer picture of the flexibility of the 37° system. It shows every "convertible sleeve" connection for the 37° flare design. For example, if 12 mm tubing is being used, a 1/2" 37° flare fitting together with a 12 mm sleeve and a standard 1/2" flare fitting nut would be all the necessary components to connect and seal a 12 mm flared tube assembly.

From this example it is evident that any 37° flare fitting body can easily be converted into a metric tube fitting with merely a sleeve change.

Fitting Dash Size	Tube O.D.	Sleeve Part Number	Nut Part Number
-4	6mm	TXS6	4 BTX-S
-5	8mm	5 TX-S	5 BTX-S
-6	10mm	TXS10	6 BTX-S
-8	12mm	TXS12	8 BTX-S
-10	14mm	TXS14	10 BTX-S
-10	15mm	TXS15	10 BTX-S
-10	16mm	10 TX-S	10 BTX-S
-12	18mm	TXS18	12 BTX-S
-12	20mm	20-12 TX-S	20-12 BTX-S
-14	22mm	TXS22	14 BTX-S
-16	25mm	TXS25	16 BTX-S
-20	28mm	TXS28	20 BTX-S
-20	30mm	TXS30	20 BTX-S
-20	32mm	TXS32	20 BTX-S
-24	35mm	TXS35	24 BTX-S
-24	38mm	24 TX-S	24 BTX-S

Table I8 — Convertible Sleeve Chart

The process also works in reverse – if a 37° flare fitting is being used on a 12 mm tube, a standard 1/2" 37° flare sleeve can be used to convert the tubing to inch sizes. This same flare will also accept a 1/2" 37° flare hose swivel which further enhances it's "replaceability" value in the field.

Assembly, Installation and Troubleshooting Procedures

For assembly, installation and troubleshooting procedures for Triple-Lok Fittings for inch and metric tubing, see [pages C6 through C9](#) of the Triple-Lok Section.

Port assembly techniques and torque values for Triple-Lok fittings with BSPT, BSPP, Metric, and ISO-6149 male stud ends can be found in the [General Technical Section \(section A\)](#).

Tube Wall Thickness

Minimum/Maximum tube wall thickness is based on the pressure holding capacity of the fittings and subject to maximum wall thickness limitations.

Fitting Dash Size	Wall Thickness When Using Inch Tubing		Wall Thickness When Using Metric Tubing	
	O.D. Inch	Wall Thickness Inch	O.D. mm	Wall Thickness mm
-2	1/8	0.010 – 0.035	–	–
-3	3/16	0.010 – 0.035	–	–
-4	1/4	0.020 – 0.065	6.0	0.5 – 2.0
-5	5/16	0.020 – 0.065	8.0	0.5 – 2.0
-6	3/8	0.020 – 0.065	10.0	0.5 – 2.0
-8	1/2	0.028 – 0.083	12.0	1.0 – 2.0
-10	5/8	0.035 – 0.095	14.0	1.0 – 2.5
-10	5/8	0.035 – 0.095	15.0	1.0 – 2.5
-10	5/8	0.035 – 0.095	16.0	1.0 – 2.5
-12	3/4	0.035 – 0.109	18.0	1.0 – 3.0
-12	3/4	0.035 – 0.109	20.0	1.0 – 3.0
-14	7/8	0.035 – 0.109	22.0	1.0 – 3.0
-16	1	0.035 – 0.120	25.0	1.0 – 3.0
-20	1 1/4	0.049 – 0.120	30.0	1.5 – 3.0
-20	1 1/4	0.049 – 0.120	32.0	1.5 – 3.0
-24	1 1/2	0.049 – 0.120	38.0	1.5 – 3.0
-32	2	0.058 – 0.134	50.0	1.5 – 3.5

Table I9 — Recommended "Min./Max" Tube Wall Thickness for Metric Triple-Lok

These recommended working pressures represent the capability of the subject fitting. Nevertheless, in some instances, the wall thickness or type of tubing, hose, or hose connector, assembled to the fitting may lower the maximum pressure to which the assembly should be exposed. It is strongly suggested that these fitting working pressure charts be used in conjunction with appropriate pressure charts for tubing or hose during the fitting selection process.

Refer to the definition of pressure rated static and pressure rated dynamic. [Contact Parker for working pressures for all other materials not shown.](#) The following values are based on

a minimum design factor of 4:1 for dynamic and 3:1 for static applications.

Pressure, Rated Static – The maximum pressure that a pressure containing envelope is capable of sustaining in an application not exceeding 30,000 operating cycles in a system free of pressure surges, shocks, vibration, and temperature excursions.

Pressure, Rated Dynamic – The maximum fluctuating pressure load that a pressure containing envelope is capable of sustaining for a minimum of one million operation cycles without failure.

					
		STATIC		DYNAMIC	
SIZE	STEEL	SS	STEEL	SS	
4M10	6000	6000	4500	4500	
5M12	6000	6000	4500	4500	
6M14	6000	6000	4500	4500	
8M16	4800	4800	3600	3600	
8M16	4800	4800	3600	3600	
10M18	4800	4800	3600	3600	
10M22	4800	4800	3600	3600	
12M22	4800	4800	3600	3600	
12M27	3000	3000	2300	2300	

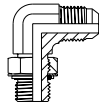
					
		STATIC		DYNAMIC	
SIZE	STEEL	SS	STEEL	SS	
4M10	3500	3500	2500	2500	
5M12	3500	3500	2500	2500	
6M14	3500	3500	2500	2500	
8M16	3500	3500	2500	2500	
8M16	3500	3500	2500	2500	
10M18	3500	3500	2500	2500	
10M22	3500	3500	2500	2500	
12M22	3500	3500	2500	2500	
12M27	3500	3500	2500	2500	

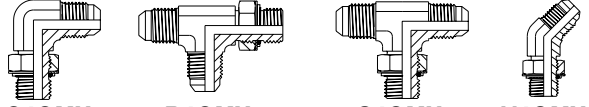
					
		STATIC		DYNAMIC	
SIZE	STEEL	SS	STEEL	SS	
4	3500	3500	2500	2500	
4-4	3500	3500	2500	2500	
5	3500	3500	2500	2500	
5-4	3500	3500	2500	2500	
5-6	3500	3500	2500	2500	
6	3500	3500	2500	2500	
6-6	3500	3500	2500	2500	
8	3500	3500	2500	2500	
8-4	3500	3500	2500	2500	
8-8	3500	3500	2500	2500	
10	3500	3500	2500	2500	
10-6	3500	3500	2500	2500	
10-12	3500	3500	2500	2500	
12	3500	3500	2500	2500	
12-8	3500	3500	2500	2500	
12-16	3500	3500	2500	2500	
16	3500	3500	2500	2500	
16-12	3500	3500	2500	2500	
20	3000	3000	2000	2000	
20-16	3500	3500	2500	2500	
24	3000	3000	2000	2000	
24-20	3000	3000	2000	2000	

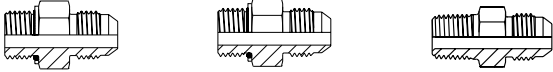
							
		F4OMX		F42EDMX		F3MX	
		STATIC		DYNAMIC			
SIZE	STEEL	SS	STEEL	SS	STEEL	SS	SS
4	8000	9600	5000	6000			
4-4	8000	9600	5000	6000			
4-6	8000	9600	5000	6000			
4-8	4500	5400	3500	4200			
5-4	8000	9600	5000	6000			
5-6	8000	9600	5000	6000			
6	8000	9600	5000	6000			
6-6	8000	9600	5000	6000			
6-8	4500	5400	3500	4200			
8	8000	9600	5000	6000			
8-12	4500	5400	3500	4200			
8-4	8000	9600	5000	6000			
8-8	4500	5400	3500	4200			
10	4500	5400	3500	4200			
10-6	8000	9600	5000	6000			
12	4500	5400	3500	4200			
12-16	4500	5400	3500	4200			
12-8	4500	5400	3500	4200			
16	4500	5400	3500	4200			
16-12	4500	5400	3500	4200			
16-20	3000	3600	2000	2400			
20	3000	3600	2000	2400			
24	3000	3600	2000	2400			
24-20	3000	3600	2000	2400			

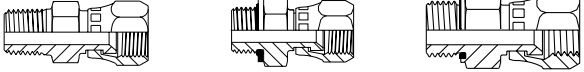
							
		F63MX		F64OMX		F642EDMX	
		STATIC		DYNAMIC			
SIZE	STEEL	SS	STEEL	SS	STEEL	SS	SS
4	8000	9600	5000	6000			
4-4	8000	9600	5000	6000			
5-4	8000	9600	5000	6000			
6	6000	7200	4500	5400			
6-6	6000	7200	4500	5400			
8	5000	6000	4000	4800			
8-4	5000	6000	4000	4800			
10	5000	6000	4000	4800			
12	4000	4800	3500	4200			
12-8	4000	4800	3500	4200			
16	3000	3600	2500	3000			
16-12	3000	3600	2500	3000			
20	3000	3600	2500	3000			
24	2500	3000	2000	2400			

					
		F68OMX		F687OMX	
		STATIC		DYNAMIC	
SIZE	STEEL	SS	STEEL	SS	SS
4M10	8000	9600	5000	6000	
5M12	8000	9600	5000	6000	
6M14	6000	7200	4500	5400	
8M16	5000	6000	4000	4800	
10M22	5000	6000	4000	4800	
12M27	4000	4800	3500	4200	
16M33	3000	3600	2500	3000	

					
		F8OMX		F82EDMX	
		STATIC		DYNAMIC	
SIZE	STEEL	SS	STEEL	SS	SS
4M10	8000	9600	5000	6000	
5M12	8000	9600	5000	6000	
6M14	8000	9600	5000	6000	
8M16	8000	9600	5000	6000	
8M18	8000	9600	5000	6000	
10M18	4500	5400	3500	4200	
10M20	4500	5400	3500	4200	
10M22	4500	5400	3500	4200	
12M22	4500	5400	3500	4200	
12M24	4500	5400	3500	4200	
12M27	4500	5400	3500	4200	
16M27	4500	5400	3500	4200	
16M33	4500	5400	3500	4200	
20M42	3000	3600	2000	2400	
24M48	3000	3600	2000	2400	

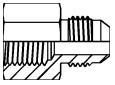
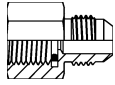

					
		G4MX		G4MXMO	
		STATIC		DYNAMIC	
SIZE		STEEL	SS	STEEL	SS
4		8000	9600	5000	6000
4-4		8000	9600	5000	6000
5		8000	9600	5000	6000
6		8000	9600	5000	6000
6-6		8000	9600	5000	6000
8		8000	9600	5000	6000
8-8		4500	5400	3500	4200
10		4500	5400	3500	4200
12		4500	5400	3500	4200
16		4000	4800	3000	3600

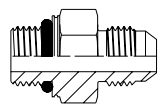
				
F87OMX				
	STATIC		DYNAMIC	
SIZE	STEEL	SS	STEEL	SS
4M10	7700	9240	5800	6960
5M12	7700	9240	5800	6960
6M14	7700	9240	5800	6960
8M16	6050	7260	4550	5460
8M16	6050	7260	4550	5460
10M18	6050	7260	4550	5460
10M22	6050	7260	4550	5460
12M22	6050	7260	4550	5460
12M27	3850	4620	2900	3480
16M27	3850	4620	2900	3480
16M33	3850	4620	2900	3480
20M42	3850	4620	2900	3480
24M48	3850	4620	2900	3480

Male Elbow – BSPT

C3MX

Flare Tube End / Male BSPT Pipe End

Part Number Information
C3MX - Body only

All dimensions are in millimeters

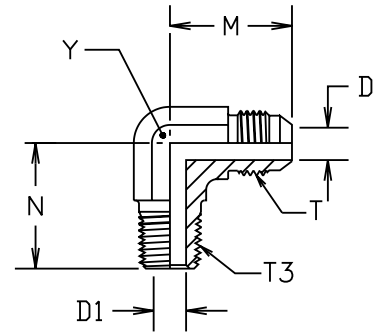

TUBE FITTING PART #	TUBE O.D. (mm)	T TUBE END UN/UNF-2A	T3 BSPT MALE PIPE THREAD	D (mm)	D1 (mm)	M (mm)	N (mm)	Y (mm)	STANDARD MATERIAL FROM STOCK		
									S	SS	B
4C3MX	6	7/16-20	1/8-28	4.4	4.8	22.6	19.8	11	•		
4-4C3MX	6	7/16-20	1/4-19	4.4	4.8	26.6	27.7	14	•		
5C3MX	8	1/2-20	1/8-28	6.0	4.8	24.1	19.8	13	•		
5-4C3MX	8	1/2-20	1/4-19	6.0	7.0	26.6	27.7	14	•		
6C3MX	10	9/16-18	1/4-19	7.5	7.0	26.9	27.7	14	•		
6-6C3MX	10	9/16-18	3/8-19	7.5	10.3	29.0	31.0	19	•		
6-8C3MX	10	9/16-18	1/2-14	7.5	13.5	31.0	37.3	22	•		
8-4C3MX	12	3/4-16	1/4-19	9.9	7.0	31.8	31.0	19	•		
8C3MX	12	3/4-16	3/8-19	9.9	10.3	31.8	31.0	19	•		
8-8C3MX	12	3/4-16	1/2-14	9.9	13.5	33.8	37.3	22	•		
10-6C3MX	14,15,16	7/8-14	3/8-19	12.3	10.3	36.5	32.5	22	•		
10C3MX	14,15,16	7/8-14	1/2-14	12.3	13.5	36.8	37.3	22	•		
10-12C3MX	14,15,16	7/8-14	3/4-14	12.3	18.0	39.2	40.4	27	•		
12-8C3MX	18,20	1 1/16-12	1/2-14	15.5	13.5	42.2	40.4	27	•		
12C3MX	18,20	1 1/16-12	3/4-14	15.5	18.0	42.2	40.4	27	•		
16-12C3MX	25	1 5/16-12	3/4-14	21.5	18.0	46.0	45.2	33	•		
16C3MX	25	1 5/16-12	1-11	21.5	23.8	46.0	50.0	33	•		
20-16C3MX	30,32	1 5/8-12	1-11	27.5	23.8	52.3	59.7	41	•		
20C3MX	30,32	1 5/8-12	1 1/4-11	27.5	31.7	52.3	60.5	41	•		
24C3MX	38	1 7/8-12	1 1/2-11	33.0	38.0	59.2	67.1	48	•		



Male Connector – BSPT F3MX

Flare Tube End / Male BSPT Pipe End

Part Number Information
F3MX - Body only

All dimensions are in millimeters

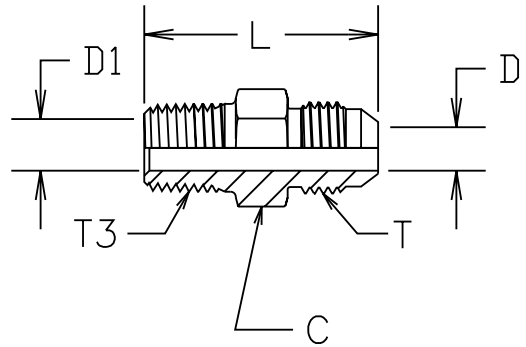

TUBE FITTING PART #	TUBE O.D. (mm)	T TUBE END UN/UNF-2A	T3 BSPT MALE PIPE THREAD	C (mm)	D (mm)	D1 (mm)	L (mm)	STANDARD MATERIAL FROM STOCK		
								S	SS	B
4F3MX	6	7/16-20	1/8-28	13	4.4	4.4	30.7	•		
4-4F3MX	6	7/16-20	1/4-19	14	4.4	4.4	35.3	•		
5F3MX	8	1/2-20	1/8-28	14	6.0	4.8	30.7	•		
5-4F3MX	8	1/2-20	1/4-19	14	6.0	6.0	35.3	•		
6F3MX	10	9/16-18	1/4-19	16	7.5	7.5	35.6	•		
6-6F3MX	10	9/16-18	3/8-19	19	7.5	7.5	35.6	•		
6-8F3MX	10	3/4-16	1/2-14	22	7.5	7.5	41.1	•		
8-4F3MX	12	3/4-16	1/4-19	19	9.9	7.0	38.1	•		
8F3MX	12	3/4-16	3/8-19	19	9.9	9.9	38.1	•		
8-8F3MX	12	3/4-16	1/2-14	22	9.9	9.9	43.7	•		
10-6F3MX	14,15,16	7/8-14	3/8-19	24	12.3	10.3	41.9	•		
10F3MX	14,15,16	7/8-14	1/2-14	24	12.3	12.3	46.7	•		
10-12F3MX	14,15,16	7/8-14	3/4-14	27	12.3	12.3	49.3	•		
12-8F3MX	18,20	1 1/16-12	1/2-14	27	15.5	13.5	50.8	•		
12F3MX	18,20	1 1/16-12	3/4-14	27	15.5	15.5	50.8	•		
12-16F3MX	18,20	1 1/16-12	1-11	36	15.5	15.5	56.6	•		
16-12F3MX	25	1 5/16-12	3/4-14	36	21.5	18.0	53.1	•		
16F3MX	25	1 5/16-12	1-11	36	21.5	21.5	57.9	•		
20-16F3MX	30,32	1 5/8-12	1-11	46	27.5	23.8	60.2	•		
20F3MX	30,32	1 5/8-12	1 1/4-11	46	27.5	27.5	61.0	•		
24F3MX	38	1 7/8-12	1 1/2-11	50	33.0	33.0	66.3	•		

Male 45° Elbow – BSPT V3MX

Flare Tube End / Male BSPT Pipe End

Part Number Information
V3MX - Body only

All dimensions are in millimeters

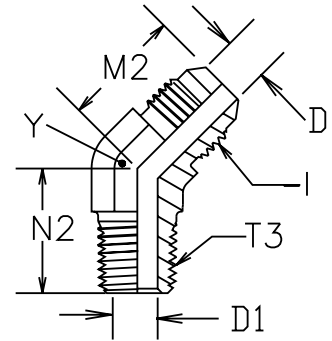

TUBE FITTING PART #	TUBE O.D. (mm)	T TUBE END UN/UNF-2A	T3 BSPT MALE PIPE THREAD	D (mm)	D1 (mm)	M2 (mm)	N2 (mm)	Y (mm)	STANDARD MATERIAL FROM STOCK		
									S	SS	B
4V3MX	6	7/16-20	1/8-28	4.4	4.8	18.3	16.3	11	•		
4-4V3MX	6	7/16-20	1/4-19	4.5	7.0	20.8	21.8	14	•		
6V3MX	10	9/16-18	1/4-19	7.5	7.0	21.1	21.8	14	•		
6-6V3MX	10	9/16-18	3/8-19	7.5	10.3	22.1	24.1	19	•		
8V3MX	12	3/4-16	3/8-19	9.9	10.3	24.9	24.1	19	•		
8-8V3MX	12	3/4-16	1/2-14	9.9	13.5	25.2	29.7	22	•		
12V3MX	18, 20	1 1/16-12	3/4-14	15.5	18.0	32.5	30.5	27	•		

Male Elbow – BSPP (for ISO 1179-1 / DIN 3852-2 Port) C4OMX

Flare Tube End / Male BSPP Port End

Part Number Information
C4OMX - Body with O-ring and Retaining Ring *

All dimensions are in millimeters

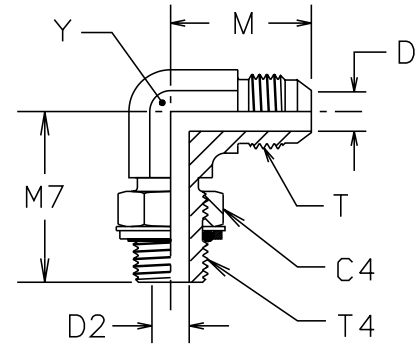

TUBE FITTING PART #	TUBE O.D. (mm)	T TUBE END UN/UNF-2A	T4 BSPP MALE PIPE THREAD	C4 (mm)	D (mm)	D2 (mm)	M (mm)	M7 (mm)	Y (mm)	STANDARD MATERIAL FROM STOCK		
										S	SS	B
4C4OMX	6	7/16-20	1/8-28	14	4.4	4.4	22.6	26.2	11	•		
4-4C4OMX	6	7/16-20	1/4-19	19	4.4	7.5	22.6	31.8	14	•		
5C4OMX	8	1/2-20	1/8-28	14	6.0	4.4	24.1	27.7	13	•		
5-4C4OMX	8	1/2-20	1/4-19	19	6.0	7.5	26.6	31.8	14	•		
5-6C4OMX	8	1/2-20	3/8-19	22	6.0	9.9	28.5	36.8	19	•		
6C4OMX	10	9/16-18	1/4-19	19	7.5	7.5	26.9	31.8	14	•		
6-6C4OMX	10	9/16-18	3/8-19	22	7.5	9.9	29.0	36.8	19	•		
8-4C4OMX	12	3/4-16	1/4-19	19	9.9	7.5	31.8	36.8	19	•		
8C4OMX	12	3/4-16	3/8-19	22	9.9	9.9	31.8	36.8	19	•		
8-8C4OMX	12	3/4-16	1/2-14	27	9.9	12.3	33.8	43.2	22	•		
10-6C4OMX	16	7/8-14	3/8-19	22	12.3	9.9	36.8	37.1	22	•		
10C4OMX	14,15,16	7/8-14	1/2-14	27	12.3	12.3	36.8	43.2	22	•		
10-12C4OMX	15	7/8-14	3/4-14	36	12.3	15.5	39.2	49.3	27	•		
12-8C4OMX	18,20	1 1/16-12	1/2-14	27	15.5	12.3	42.2	49.3	27	•		
12C4OMX	18,20	1 1/16-12	3/4-14	36	15.5	15.5	42.2	49.3	27	•		
12-16C4OMX	18	1 1/16-12	1-11	41	15.5	21.5	44.7	52.1	33	•		
16-12C4OMX	25	1 5/16-12	3/4-14	36	21.5	15.5	46.0	48.2	33	•		
16C4OMX	25	1 5/16-12	1-11	41	21.5	21.5	46.0	52.1	33	•		
20-16C4OMX	30,32	1 5/8-12	1-11	41	27.5	21.5	52.3	57.2	41	•		
20C4OMX	30,32	1 5/8-12	1 1/4-11	50	27.5	27.5	52.3	57.2	41	•		
24-20C4OMX	38	1 7/8-12	1 1/4-11	50	33.0	27.5	59.2	60.7	48	•		
24C4OMX	38	1 7/8-12	1 1/2-11	55	33.0	33.0	59.2	60.7	48	•		

*See page I63 for replacement O-rings and retaining rings.

Manometer Pressure Gauge Connector G4MXMO

Flare Tube End / Female BSPP Pressure Gauge End

Part Number Information
G4MXSMO - Steel Body with Sealing Ring*

All dimensions are in millimeters

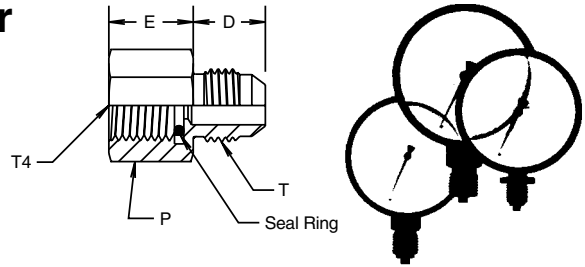

TUBE FITTING PART #	TUBE O.D. (mm)	T TUBE END UN/UNF-2A	T4 BSPP FEMALE PIPE THREAD	D (mm)	E (mm)	P (mm)	STANDARD MATERIAL FROM STOCK		
							S	SS	B
4-4G4MXSMO	6	7/16-20	1/4-19	14.0	17.0	17	•		
4-8G4MXSMO	6	7/16-20	1/2-14	14.0	27.0	27			
5-4G4MXSMO	8	1/2-20	1/4-19	14.0	14.0	17			
5-8G4MXSMO	8	1/2-20	1/2-14	14.0	27.0	27			
6G4MXSMO	10	9/16-18	1/4-19	14.1	13.9	17			
6-8G4MXSMO	10	9/16-18	1/2-14	14.1	20.9	27			
8-4G4MXSMO	12	3/4-16	1/4-19	16.7	14.3	19	•		
8-8G4MXSMO	12	3/4-16	1/2-14	16.7	21.3	27			

* Replacement sealing ring part numbers are: **M25180** for T4 thread of 1/4-19
M25182 for T4 thread of 1/2-14

37° Swivel to Male BSPT F63MX

Swivel Nut / Male BSPT Port End

Part Number Information
F63MX - Body only

All dimensions are in millimeters

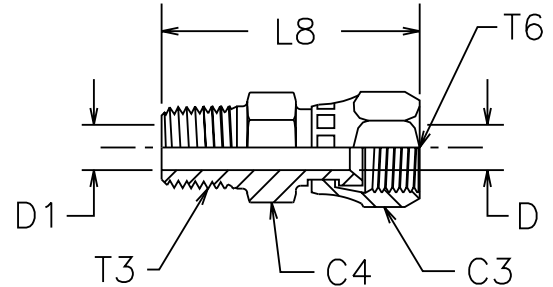

TUBE FITTING PART #	TUBE O.D. (mm)	T6 TUBE END UN/UNF-2B	T3 BSPT MALE PIPE THREAD	C3 (mm)	C4 (mm)	D (mm)	D1 (mm)	L8 (mm)	STANDARD MATERIAL FROM STOCK		
									S	SS	B
4-4F63MX	6	7/16-20	1/4-19	16	14	4.4	4.4	38.1	•		
5-4F63MX	8	1/2-20	1/4-19	16	14	6.0	6.0	38.4	•		
6F63MX	10	9/16-18	1/4-19	19	14	7.5	7.5	40.3	•		
6-6F63MX	10	9/16-18	3/8-19	19	19	7.5	7.5	40.6	•		
8-4F63MX	12	3/4-16	1/4-19	22	19	9.9	7.0	42.8	•		
8F63MX	12	3/4-16	3/8-19	22	19	9.9	9.9	42.8	•		
10F63MX	14, 15, 16	7/8-14	1/2-14	27	22	12.3	12.3	51.2	•		
12-8F63MX	20	1 1/8-12	1/2-14	32	27	15.5	13.5	54.6	•		
12F63MX	18, 20	1 1/16-12	3/4-14	32	27	15.5	15.5	54.6	•		
16-12F63MX	25	1 5/16-12	3/4-14	38	32	21.5	18.0	58.9	•		
16F63MX	25	1 5/16-12	1-11	38	36	21.5	21.5	63.8	•		
20F63MX	30, 32	1 5/8-12	1 1/4-11	50	46	27.5	27.5	69.0	•		

37° Swivel to Male BSPP (for ISO 1179-1 / DIN 3852-2 Port) F64OMX

Swivel Nut End / Male BSPP Port End

Part Number Information
F64OMX - Body with O-ring and Retaining Ring*

All dimensions are in millimeters

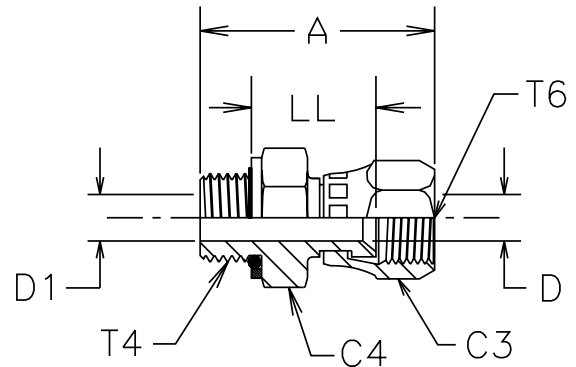

TUBE FITTING PART #	TUBE O.D. (mm)	T6 TUBE END UN/UNF-2B	T4 BSPP MALE PIPE THREAD	A (mm)	C3 (mm)	C4 (mm)	D (mm)	D1 (mm)	LL (mm)	STANDARD MATERIAL FROM STOCK		
										S	SS	B
4F64OMX	6	7/16-20	1/8-28	31.7	16	16	4.4	4.4	16.7	•		
4-4F64OMX	6	7/16-20	1/4-19	34.7	16	19	4.4	4.4	16.6	•		
5-4F64OMX	8	1/2-20	1/4-19	35.2	16	19	6.0	6.0	15.7	•		
6F64OMX	10	9/16-18	1/4-19	37.1	19	19	7.5	7.5	18.2	•		
6-6F64OMX	10	9/16-18	3/8-19	38.1	19	22	7.5	7.5	19.2	•		
8F64OMX	12	3/4-16	3/8-19	40.8	22	22	9.9	9.9	20.7	•		
10F64OMX	14, 15, 16	7/8-14	1/2-14	48.8	27	30	12.3	12.3	23.6	•		
12F64OMX	18, 20	1 1/16-12	3/4-14	51.0	32	36	15.5	15.5	25.5	•		
16F64OMX	25	1 5/16-12	1-11	59.4	38	46	21.5	21.5	28.3	•		
20F64OMX	30, 32	1 5/8-12	1 1/4-11	64.3	50	50	27.5	27.5	32.9	•		
24F64OMX	38	1 7/8-12	1 1/2-11	70.1	55	60	33.0	33.0	35.2	•		

*See page I63 for replacement O-rings and retaining rings.

37° Swivel to Male BSPP (for ISO 1179-1 / DIN 3852-2 Port) F642EDMX

Swivel Nut End / Male BSPP Port End

Part Number Information
F642EDMX - Body with EOlastic "ED" Seal

All dimensions are in millimeters

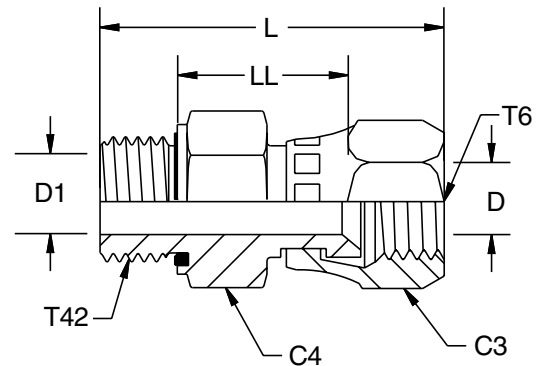

TUBE FITTING PART #	TUBE O.D. (mm)	T6 TUBE END UN/UNF-2B	T42 BSPP MALE PIPE THREAD	C3 (mm)	C4 (mm)	D (mm)	D1 (mm)	L (mm)	LL (mm)	STANDARD MATERIAL FROM STOCK		
										S	SS	B
5F642EDMX	8	1/2-20	1/8-28	16	14	6.0	4.0	24.7	16.7	•		
8-4F642EDMX	12	3/4-16	1/4-19	22	19	9.9	7.0	33.4	21.4	•		
10-6F642EDMX	14, 15, 16	7/8-14	3/8-19	27	22	12.3	12.3	35.4	23.4	•		
12-8F642EDMX	18, 20	1 1/16-12	1/2-14	32	27	15.5	14.0	39.7	25.7	•		
20-16F642EDMX	28, 30, 32	1 5/8-12	1-11	50	41	27.5	23.0	54.0	36.0	•		
24-20F642EDMX	35, 38	1 7/8-12	1 1/4-11	60	50	33.0	30.0	60.0	40.0	•		

*See page H123 for replacement "ED" seal rings.

37° Swivel to Male Metric Parallel Thread (for ISO 9974-1 / DIN 3852-1 Port)

F68OMX

Swivel Nut End / Male Metric Parallel Thread Port End

Part Number Information
F68OMX - Body with O-ring and Retaining Ring*

All dimensions are in millimeters

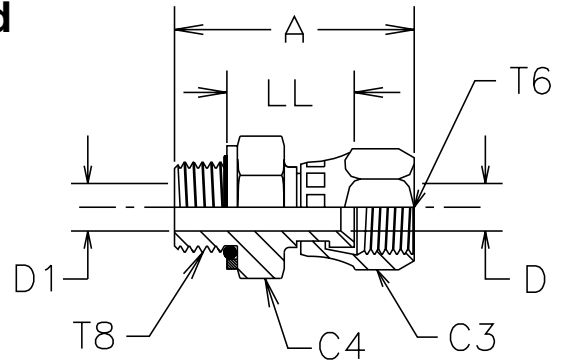

TUBE FITTING PART #	TUBE O.D. (mm)	T6 TUBE END UN/UNF-2B	T8 MALE METRIC PARALLEL THREAD	A (mm)	C3 (mm)	C4 (mm)	D (mm)	D1 (mm)	LL (mm)	STANDARD MATERIAL FROM STOCK		
										S	SS	B
4M10F68OMX	6	7/16-20	M10x1	34.3	16	16	4.4	4.4	17.4	•		
5M12F68OMX	8	1/2-20	M12x1.5	37.9	16	19	6.0	6.0	18.5	•		
6M14F68OMX	10	9/16-18	M14x1.5	38.5	19	19	7.5	7.5	19.3	•		
8M16F68OMX	12	3/4-16	M16x1.5	42.4	22	22	9.9	9.0	22.3	•		
10M22F68OMX	14, 15, 16	7/8-14	M22x1.5	47.9	27	27	12.3	12.3	24.1	•		
12M27F68OMX	18, 20	1 1/16-12	M27x2	52.3	32	32	15.5	15.5	25.4	•		
16M33F68OMX	25	1 5/16-12	M33x2	57.4	38	41	27.5	27.5	28.2	•		

*See page I64 for replacement O-rings and retaining rings.

37° Swivel to ISO 6149

F687OMX

Swivel Nut / Male ISO 6149-3
(Metric Parallel Thread O-ring Port End)

Part Number Information
F687OMX - Body with O-ring

All dimensions are in millimeters

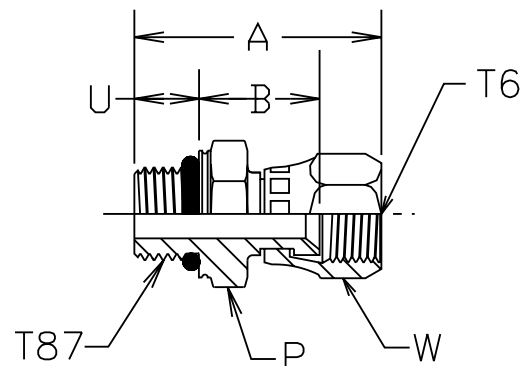

TUBE FITTING PART #	TUBE O.D. (mm)	T6 TUBE END UN/UNF-2B	T87 MALE METRIC PARALLEL THREAD	B (mm)	A (mm)	C3 (mm)	C4 (mm)	U (mm)	STANDARD MATERIAL FROM STOCK		
									S	SS	B
4M10F687OMX	6	7/16-20	M10x1	16.4	33.8	16	16	8.5	•		
5M12F687OMX	8	1/2-20	M12x1.5	20.8	44.0	22	22	11.0	•		
6M14F687OMX	10	9/16-18	M14x1.5	21.4	45.7	22	24	11.0	•		
8M16F687OMX	12	3/4-16	M16x1.5	22.8	46.6	27	27	11.5	•		
10M22F687OMX	14, 15, 16	7/8-14	M22x1.5	22.8	48.6	27	27	13.0	•		
12M27F687OMX	18, 20	1 1/16-12	M27x2	23.4	53.9	32	32	16.0	•		
16M33F687OMX	25	1 5/16-12	M33x2	25.2	57.5	38	41	16.0	•		

For O-ring part number, see page I35.

**Male Connector – BSPP
(for ISO 1179-1 / DIN 3852-2 Port)**
F4OMX

Flare Tube End / Male BSPP Port End

Part Number Information
F4OMX - Body with O-ring and Retaining Ring*

All dimensions are in millimeters

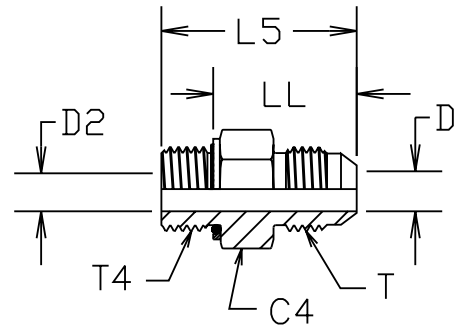

TUBE FITTING PART #	TUBE O.D. (mm)	T TUBE END UN/UNF-2A	T4 BSPP MALE PIPE THREAD	C4 (mm)	D (mm)	D2 (mm)	L5 (mm)	LL (mm)	STANDARD MATERIAL FROM STOCK		
									S	SS	B
4F4OMX	6	7/16-20	1/8-28	16	4.4	4.4	28.7	22.5	•		
4-4F4OMX	6	7/16-20	1/4-19	19	4.4	4.4	32.0	22.7	•		
4-6F4OMX	6	7/16-20	3/8-19	22	4.4	4.4	33.0	23.7	•		
4-8F4OMX	6	7/16-20	1/2-14	30	4.4	4.4	38.6	26.0	•		
5-4F4OMX	8	1/2-20	1/4-19	19	6.0	6.0	32.0	22.7	•		
5-6F4OMX	8	1/2-20	3/8-19	22	6.0	6.0	33.0	33.7	•		
6F4OMX	10	9/16-18	1/4-19	19	7.5	7.5	32.0	22.7	•		
6-6F4OMX	10	9/16-18	3/8-19	22	7.5	7.5	33.0	23.7	•		
6-8F4OMX	10	9/16-18	1/2-14	30	7.5	7.5	38.6	26.0	•		
8-4F4OMX	12	3/4-16	1/4-19	19	9.9	7.5	35.0	25.7	•		
8F4OMX	12	3/4-16	3/8-19	22	9.9	9.9	36.0	26.7	•		
8-8F4OMX	12	3/4-16	1/2-14	30	9.9	9.9	41.4	28.8	•		
8-12F4OMX	12	3/4-16	3/4-14	36	9.9	9.9	42.4	29.8	•		
10-6F4OMX	14, 15, 16	7/8-14	3/8-19	24	12.3	9.9	39.1	29.8	•		
10F4OMX	14, 15, 16	7/8-14	1/2-14	30	12.3	12.3	43.9	31.3	•		
12-8F4OMX	18, 20	1 1/16-12	1/2-14	30	15.5	12.3	46.7	34.1	•		
12F4OMX	18, 20	1 1/16-12	3/4-14	36	15.5	15.5	47.5	34.9	•		
12-16F4OMX	18, 20	1 1/16-12	1-11	46	15.5	15.5	52.6	36.7	•		
16-12F4OMX	25	1 5/16-12	3/4-14	36	21.5	15.5	48.5	35.9	•		
16F4OMX	25	1 5/16-12	1-11	46	21.5	21.5	53.6	37.7	•		
16-20F4OMX	25	1 5/16-12	1 1/4-11	50	21.5	21.5	55.1	39.7	•		
20F4OMX	30, 32	1 5/8-12	1 1/4-11	50	27.5	27.5	56.9	41.0	•		
24-20F4OMX	38	1 7/8-12	1 1/4-11	50	33.0	27.5	60.4	44.5	•		
24F4OMX	38	1 7/8-12	1 1/2-11	55	33.0	33.0	61.0	45.1	•		

*See page I63 for replacement O-rings and retaining rings.

Male Connector – BSPP (for ISO 1179-1 / DIN 3852-2 Port) F42EDMX

Flare Tube End / Male BSPP Port End with EOlasic Seal

Part Number Information
F42EDMX - Body with Eolastic "ED" Seal

All dimensions are in millimeters

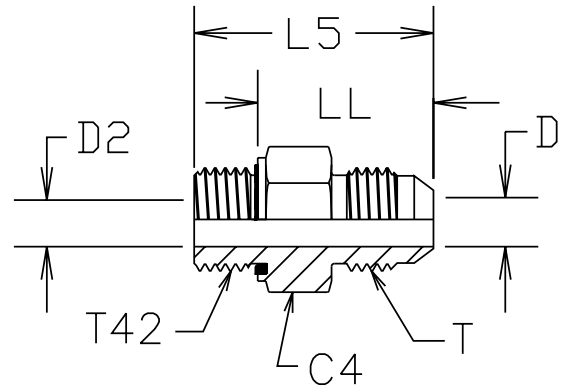

TUBE FITTING PART #	TUBE O.D. (mm)	T TUBE END UN/UNF-2A	T42 BSPP MALE PIPE THREAD	C4 (mm)	D (mm)	D2 (mm)	L5 (mm)	LL (mm)	STANDARD MATERIAL FROM STOCK		
									S	SS	B
4F42EDMX	6	7/16-20	1/8-28	16	4.4	4.0	33.0	22.0	•		
4-4F42EDMX	6	7/16-20	1/4-19	19	4.4	4.4	34.8	22.8	•		
4-6F42EDMX	6	7/16-20	3/8-19	22	4.4	4.4	35.7	23.7	•		
4-8F42EDMX	6	7/16-20	1/2-14	30	4.4	4.4	39.2	25.2	•		
5F42EDMX	8	1/2-20	1/8-28	14	8.0	4.0	30.0	22.0	•		
5-4F42EDMX	8	1/2-20	1/4-19	19	6.0	6.0	34.8	22.8	•		
5-6F42EDMX	8	1/2-20	3/8-19	22	6.0	6.0	35.7	23.7	•		
6-2F42EDMX	10	9/16-18	1/8-28	16	7.5	4.0	31.0	23.1	•		
6F42EDMX	10	9/16-18	1/4-19	19	7.5	7.5	35.1	23.1	•		
6-6F42EDMX	10	9/16-18	3/8-19	22	7.5	7.5	36.0	24.0	•		
6-8F42EDMX	10	9/16-18	1/2-14	30	7.5	7.5	39.4	25.4	•		
8-4F42EDMX	12	3/4-16	1/4-19	19	9.9	7.0	38.7	36.7	•		
8F42EDMX	12	3/4-16	3/8-19	22	9.9	9.0	33.5	26.5	•		
8-8F42EDMX	12	3/4-16	1/2-14	30	9.9	9.9	42.0	28.0	•		
8-12F42EDMX	12	3/4-16	3/4-14	36	9.9	9.9	45.6	29.6	•		
10-6F42EDMX	14, 15, 16	7/8-14	3/8-19	24	12.3	9.0	42.6	30.6	•		
10F42EDMX	14, 15, 16	7/8-14	1/2-14	30	12.3	12.3	44.5	30.5	•		
10-12F42EDMX	14, 15, 16	7/8-14	3/4-14	32	12.3	12.3	48.1	32.1	•		
12-6F42EDMX	18, 20	1 1/16-12	3/8-19	27	15.5	9.0	50.1	38.1	•		
12-8F42EDMX	18, 20	1 1/16-12	1/2-14	30	15.5	14.0	49.0	35.0	•		
12F42EDMX	18, 20	1 1/16-12	3/4-14	36	15.5	15.5	50.9	34.9	•		
12-16F42EDMX	18, 20	1 1/16-12	1-11	46	15.5	15.5	53.4	35.4	•		
16-12F42EDMX	25	1 5/16-12	3/4-14	36	18.0	18.0	52.7	36.7	•		
16F42EDMX	25	1 5/16-12	1-11	46	21.5	21.5	54.7	36.7	•		
16-20F42EDMX	25	1 5/16-12	1 1/4-11	50	21.5	21.5	58.7	38.7	•		
20-16F42EDMX	30, 32	1 5/8-12	1-11	46	27.5	23.0	62.1	44.1	•		
20F42EDMX	30, 32	1 5/8-12	1 1/4-11	50	27.5	23.0	60.0	40.0	•		
20-24F42EDMX	30, 32	1 5/8-12	1 1/2-11	55	27.5	27.5	63.8	41.8	•		
24-20F42EDMX	38	1 7/8-12	1 1/4-11	50	33.0	30.0	63.8	49.2	•		
24F42EDMX	38	1 7/8-12	1 1/2-11	55	33.0	33.0	67.1	45.1	•		

See page H123 for replacement "ED" seal rings.

Male 45° Elbow – BSPP (for ISO 1179-1 / DIN 3852-2 Port) V4OMX

Flare Tube End / Male BSPP Port End

Part Number Information
V4OMX - Body with O-ring and Retaining Ring*

All dimensions are in millimeters

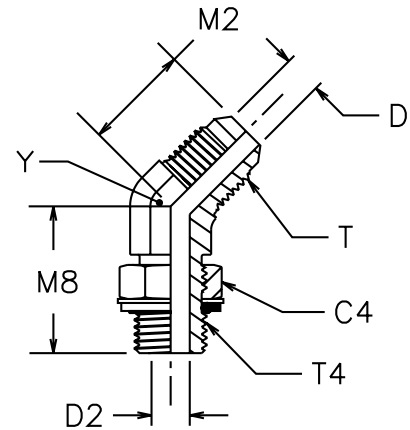

TUBE FITTING PART #	TUBE O.D. (mm)	T TUBE END UN/UNF-2A	T4 BSPP MALE PIPE THREAD	C4 (mm)	D (mm)	D2 (mm)	M2 (mm)	M8 (mm)	Y (mm)	STANDARD MATERIAL FROM STOCK		
										S	SS	B
4V4OMX	6	7/16-20	1/8-28	14	4.4	4.4	18.3	26.7	11	•		
6V4OMX	10	9/16-18	1/4-19	19	7.5	7.5	21.1	29.0	14	•		
8V4OMX	12	3/4-16	3/8-19	22	9.9	9.9	24.9	33.0	19	•		
10V4OMX	14,15,16	7/8-14	1/2-14	27	12.3	12.3	28.2	38.6	22	•		
12V4OMX	18,20	1 1/16-12	3/4-14	36	15.5	15.5	32.5	43.9	27	•		
16V4OMX	25	1 5/16-12	1-11	41	21.5	21.5	37.2	47.2	33	•		

*See page I63 for replacement O-rings and retaining rings.

Male Branch Tee – BSPP (for ISO 1179-1 / DIN 3852-2 Port) S4OMX

Flare Tube End / Male BSPP Port End

Part Number Information
S4OMX - Body with O-ring and Retaining Ring*

All dimensions are in millimeters

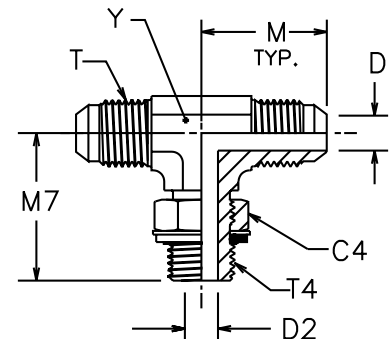

TUBE FITTING PART #	TUBE O.D. (mm)	T TUBE END UN/UNF-2A	T4 BSPP MALE PIPE THREAD	C4 (mm)	D (mm)	D2 (mm)	M (mm)	M7 (mm)	Y (mm)	STANDARD MATERIAL FROM STOCK		
										S	SS	B
4S4OMX	6	7/16-20	1/8-28	14	4.4	4.4	22.6	26.2	11	•		
6S4OMX	10	9/16-20	1/4-19	19	7.5	7.5	26.9	31.8	14	•		
8S4OMX	12	3/4-16	3/8-19	22	9.9	9.9	31.8	36.8	19	•		
10S4OMX	14,15,16	7/8-14	1/2-14	27	12.3	12.3	36.8	43.2	22	•		
12S4OMX	18,20	1 1/16-12	3/4-14	36	15.5	15.5	42.2	49.3	27	•		
16S4OMX	25	1 5/16-12	1-11	41	21.5	21.5	46.0	52.1	33	•		

*See page I63 for replacement O-rings and retaining rings.

Male Run Tee – BSPP (for ISO 1179-1 / DIN 3852-2 Port) R4OMX

Flare Tube End / Male BSPP Port End

Part Number Information
R4OMX - Body with O-ring and Retaining Ring*

All dimensions are in millimeters

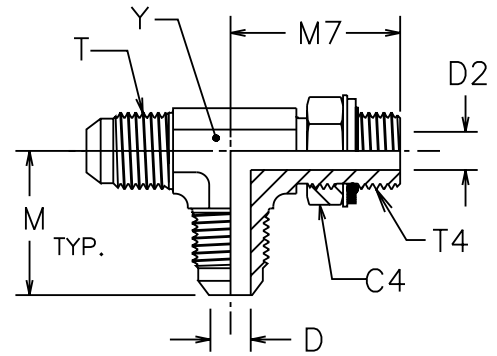

TUBE FITTING PART #	TUBE O.D. (mm)	T TUBE END UN/UNF-2A	T4 BSPP MALE PIPE THREAD	C4 (mm)	D (mm)	D2 (mm)	M (mm)	M7 (mm)	Y (mm)	STANDARD MATERIAL FROM STOCK		
										S	SS	B
4R4OMX	6	7/16-20	1/8-28	14	4.4	4.4	22.6	26.2	11	•		
6R4OMX	10	9/16-18	1/4-19	19	7.5	7.5	26.9	31.8	14	•		
8R4OMX	12	3/4-16	3/8-19	22	9.9	9.9	31.8	36.8	19	•		
10R4OMX	14, 15, 16	7/8-14	1/2-14	27	12.3	12.3	36.8	43.2	22	•		
12R4OMX	18, 20	1 1/16-12	3/4-14	36	15.5	15.5	42.2	49.3	27	•		
16R4OMX	25	1 5/16-12	1-11	41	21.5	21.5	46.0	52.1	33	•		
20R4OMX	28, 30, 32	1 5/8-12	1 1/4-11	50	27.5	27.5	52.3	57.2	41	•		

*See page I63 for replacement O-rings and retaining rings.

Female Connector – BSPP G4MX

Flare Tube End / Female BSPP Port End

Part Number Information
G4MX - Body only

All dimensions are in millimeters

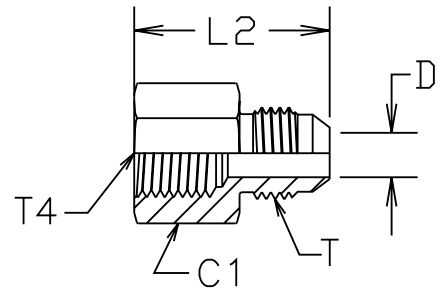

TUBE FITTING PART #	TUBE O.D. (mm)	T TUBE END UN/UNF-2A	T4 BSPP FEMALE PIPE THREAD	C1 (mm)	D (mm)	L2 (mm)	STANDARD MATERIAL FROM STOCK		
							S	SS	B
4G4MX	6	7/16-20	1/8-28	16	4.4	30.2	•		
4-4G4MX	6	7/16-20	1/4-19	19	4.4	35.3	•		
5G4MX	8	1/2-20	1/8-28	16	6.0	29.7	•		
6G4MX	10	9/16-18	1/4-19	19	7.5	35.6	•		
6-6G4MX	10	9/16-18	3/8-19	22	7.5	37.1	•		
8G4MX	12	3/4-16	3/8-19	22	9.9	39.6	•		
8-8G4MX	12	3/4-16	1/2-14	30	9.9	45.5	•		
10G4MX	14, 15, 16	7/8-14	1/2-14	30	12.3	48.0	•		
12G4MX	18, 20	1 1/16-12	3/4-14	36	15.5	52.3	•		
16G4MX	25	1 5/16-12	1-11	46	21.5	59.7	•		

**Male Connector – Metric Parallel Thread
(for ISO 9974-1 / DIN 3852-1 Port)**

F8OMX

Flare Tube End / Male Metric Parallel Thread Port End

Part Number Information
F8OMX - Body with O-ring and Retaining Ring*

All dimensions are in millimeters

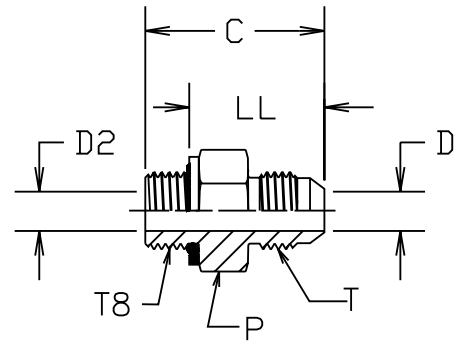

TUBE FITTING PART #	TUBE O.D. (mm)	T TUBE END UN/UNF-2A	T8 MALE METRIC PARALLEL THREAD	C (mm)	D (mm)	D2 (mm)	LL (mm)	P (mm)	STANDARD MATERIAL FROM STOCK		
									S	SS	B
4M10F8OMX	6	7/16-20	M10x1	31.0	4.4	4.4	23.5	16	•		
5M12F8OMX	8	1/2-20	M12x1.5	33.5	6.0	6.0	23.8	19	•		
6M14F8OMX	10	9/16-18	M14x1.5	33.5	7.5	7.5	23.8	19	•		
8M16F8OMX	12	3/4-16	M16x1.5	37.6	9.9	9.0	27.6	22	•		
8M18F8OMX	12	3/4-16	M18x1.5	39.1	9.9	9.9	28.6	24	•		
10M18F8OMX	14, 15, 16	7/8-14	M18x1.5	41.7	12.3	11.0	31.2	24	•		
10M22F8OMX	14, 15, 16	7/8-14	M22x1.5	42.9	12.3	12.3	31.2	27	•		
12M22F8OMX	18, 20	1 1/16-12	M22x1.5	45.5	15.5	14.0	33.8	27	•		
12M24F8OMX	18, 20	1 1/16-12	M24x1.5	44.5	15.5	14.0	33.8	30	•		
12M27F8OMX	18, 20	1 1/16-12	M27x2	49.0	15.5	15.5	35.0	32	•		
16M27F8OMX	25	1 5/16-12	M27x2	50.5	21.5	18.0	36.5	36	•		
16M33F8OMX	25	1 5/16-12	M33x2	51.6	21.5	21.5	37.6	41	•		
20M42F8OMX	30, 32	1 5/8-12	M42x2	54.9	27.5	27.5	40.9	50	•		
24M48F8OMX	38	1 7/8-12	M48x2	59.4	33.0	33.0	43.9	55			

*See page I64 for replacement O-rings and retaining rings.

**Male Connector – Metric Parallel Thread
(for ISO 9974-1 / DIN 3852-1 Port)**

F82EDMX

Flare Tube End / Male Metric Parallel Thread Port End with EOlastic Seal

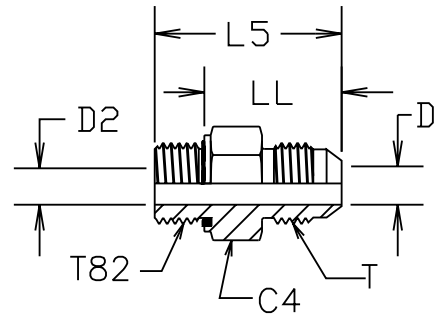

Part Number Information
F82EDMX - Body with EOlastic “ED” Seal

All dimensions are in millimeters

TUBE FITTING PART #	TUBE O.D. (mm)	T TUBE END UN/UNF-2A	T82 MALE METRIC PARALLEL THREAD	C4 (mm)	D (mm)	D2 (mm)	L5 (mm)	LL (mm)	STANDARD MATERIAL FROM STOCK		
									S	SS	B
4M10F82EDMX	6	7/16-20	M10x1	14	4.4	4.4	31.0	23.5			
5M12F82EDMX	8	1/2-20	M12x1.5	17	6.0	6.0	33.5	23.8			
6M14F82EDMX	10	9/16-18	M14x1.5	19	7.5	7.5	33.5	23.8			
6M16F82EDMX	10	9/16-18	M16x1.5	22	7.5	7.5	35.1	25.1	•		
8M16F82EDMX	12	3/4-16	M16x1.5	22	9.9	9.0	37.6	27.6	•		
8M18F82EDMX	12	3/4-16	M18x1.5	24	9.9	9.9	39.1	28.1			
10M18F82EDMX	14,15,16	7/8-14	M18x1.5	24	12.3	11.0	41.7	30.7	•		
10M22F82EDMX	14,15,16	7/8-14	M22x1.5	27	12.3	12.3	42.9	31.2	•		
12M22F82EDMX	18,20	1 1/16-12	M22x1.5	27	15.5	14.0	45.5	33.8	•		
12M27F82EDMX	18,20	1 1/16-12	M27x2	32	15.5	15.5	49.0	35.0			
16M33F82EDMX	25	1 5/16-12	M33x2	41	21.5	21.5	51.6	37.6	•		
20M42F82EDMX	30,32	1 5/8-12	M42x2	50	27.5	27.5	54.9	40.9	•		

See page H123 for replacement “ED” seal rings.



Male Connector – ISO 6149

F87OMX

Flare Tube End / Male ISO 6149-3
(Metric Parallel Thread O-Ring Port End)

Part Number Information
F87OMX - Body with O-ring

All dimensions are in millimeters

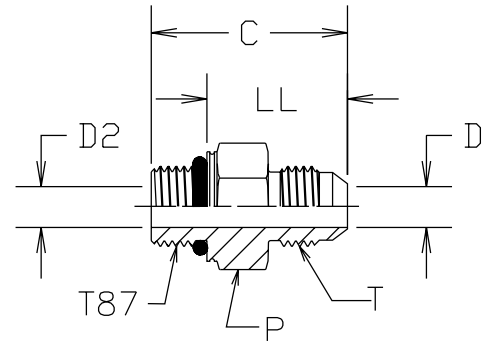

TUBE FITTING PART #	TUBE O.D. (mm)	T TUBE END UN/UNF-2A	T87 MALE METRIC PARALLEL THREAD	C (mm)	D (mm)	D2 (mm)	LL (mm)	P (mm)	STANDARD MATERIAL FROM STOCK		
									S	SS	B
4M10F87OMX	6	7/16-20	M10x1	31.0	4.4	4.4	22.5	16	•		
5M12F87OMX	8	1/2-20	M12x1.5	33.5	6.0	6.0	22.5	19	•		
6M14F87OMX	10	9/16-18	M14x1.5	33.5	7.5	7.5	22.5	19	•		
6M16F87OMX	10	9/16-18	M16x1.5	35.1	7.5	7.5	23.6	22	•		
8M16F87OMX	12	3/4-16	M16x1.5	37.6	9.9	9.0	26.1	22	•		
8M18F87OMX	12	3/4-16	M18x1.5	39.1	9.9	9.9	26.6	24	•		
10M18F87OMX	14, 15, 16	7/8-14	M18x1.5	41.7	12.3	11.0	29.2	24	•		
10M22F87OMX	14, 15, 16	7/8-14	M22x1.5	42.9	12.3	12.3	29.9	27	•		
12M22F87OMX	18, 20	1 1/16-12	M22x1.5	45.5	15.5	14.0	32.5	27	•		
12M27F87OMX	18, 20	1 1/16-12	M27x2	49.0	15.5	15.5	33.0	32	•		
16M27F87OMX	25	1 5/16-12	M27x2	50.5	21.5	18.0	34.5	36	•		
16M33F87OMX	25	1 5/16-12	M33x2	51.6	21.5	21.5	35.6	41	•		
20M42F87OMX	30, 32	1 5/8-12	M42x2	54.9	27.5	27.5	38.9	50	•		
24M48F87OMX	38	1 7/8-12	M48x2	59.4	33.0	33.0	41.9	55	•		

For O-ring part number, [see page I35](#).

**Male Elbow – Metric Parallel Thread
(for ISO 9974-1 / DIN 3852-1 Port)**

C8OMX

Flare Tube End / Male Metric Parallel Thread Port End

Part Number Information
C8OMX - Body with O-ring and Retaining Ring*

All dimensions are in millimeters

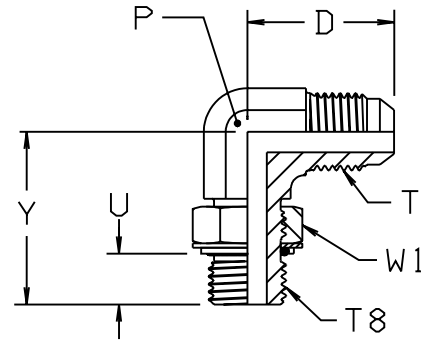

TUBE FITTING PART #	TUBE O.D. (mm)	T TUBE END UN/UNF-2A	T8 MALE METRIC PARALLEL THREAD	M (mm)	M7 (mm)	P (mm)	U (mm)	W1 (mm)	STANDARD MATERIAL FROM STOCK		
									S	SS	B
4M10C8OMX	6	7/16-20	M10x1	22.6	25.4	11	7.5	13	•		
5M12C8OMX	8	1/2-20	M12x1.5	24.1	28.5	13	7.5	16	•		
6M14C8OMX	10	9/16-18	M14x1.5	26.9	32.5	14	8.5	17	•		
8M16C8OMX	12	3/4-16	M16x1.5	31.8	36.4	19	8.5	19	•		
8M18C8OMX	12	3/4-16	M18x1.5	31.8	36.8	19	9.0	22	•		
10M18C8OMX	14, 15, 16	7/8-14	M18x1.5	36.8	41.0	22	9.0	22	•		
10M22C8OMX	14, 15, 16	7/8-14	M22x1.5	36.8	42.5	22	10.5	27	•		
12M22C8OMX	18, 20	1 1/16-12	M22x1.5	42.2	44.0	27	10.5	27	•		
12M27C8OMX	18, 20	1 1/16-12	M27x2.0	42.2	50.0	27	13.0	32	•		
16M33C8OMX	25	1 5/16-12	M33x2.0	46.0	51.4	33	14.0	38	•		

*See page I64 for replacement O-rings and retaining rings.



Male Elbow – ISO 6149

C87OMX

Flare Tube End / Male ISO 6149-3
(Metric Parallel Thread O-ring Port)

Part Number Information
C87OMX - Body with O-ring

All dimensions are in millimeters

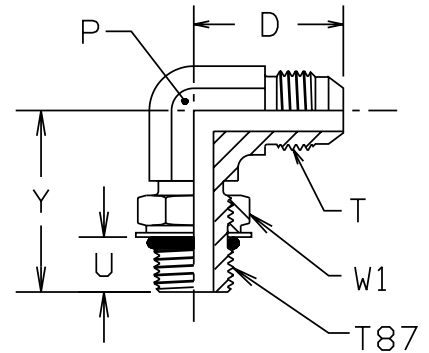

TUBE FITTING PART #	TUBE O.D. (mm)	T TUBE END UN/UNF-2A	T87 MALE METRIC PARALLEL THREAD	M (mm)	M7 (mm)	P (mm)	U (mm)	W1 (mm)	STANDARD MATERIAL FROM STOCK		
									S	SS	B
4M10C87OMX	6	7/16-20	M10x1	22.6	25.0	11	8.6	14	•		
5M12C87OMX	8	1/2-20	M12x1.5	24.1	30.0	13	11.1	17	•		
6M14C87OMX	10	9/16-18	M14x1.5	26.9	34.9	14	11.1	19	•		
8M16C87OMX	12	3/4-16	M16x1.5	31.8	35.9	19	11.5	22	•		
8M18C87OMX	12	3/4-16	M18x1.5	31.8	36.8	19	12.6	24	•		
10M18C87OMX	14, 15, 16	7/8-14	M18x1.5	36.8	40.7	22	12.6	24	•		
10M22C87OMX	14, 15, 16	7/8-14	M22x1.5	36.8	41.7	22	12.8	27	•		
12M22C87OMX	18, 20	1 1/16-12	M22x.15	42.2	44.4	27	12.8	27	•		
12M27C87OMX	18, 20	1 1/16-12	M27x2	42.2	48.5	27	15.8	32	•		
16M33C87OMX	25	1 5/16-12	M33x2	46.0	51.2	33	15.8	41	•		

For O-ring part number, see page I35.

Male 45° Elbow – ISO 6149

V87OMX

Flare Tube End / Male ISO 6149-3
(Metric Parallel Thread O-ring Port)

Part Number Information
V87OMX - Body with O-ring

All dimensions are in millimeters

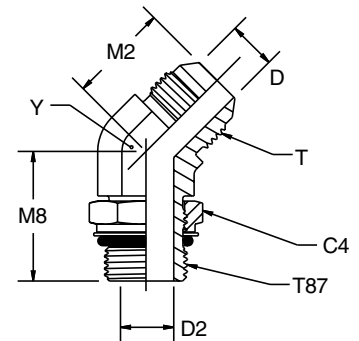

TUBE FITTING PART #	TUBE O.D. (mm)	T TUBE END UN/UNF-2A	T87 MALE METRIC PARALLEL THREAD	C4 (mm)	D (mm)	D2 (mm)	M2 (mm)	M8 (mm)	Y (mm)	STANDARD MATERIAL FROM STOCK		
										S	SS	B
8M16V87OMX	12	3/4-16	M16 X 1.5	22	9.9	9.0	24.9	32.1	19	•		
10M22V87OMX	14, 15, 16	7/8-14	M22 X 1.5	27	12.3	14.0	28.2	37.2	22	•		
12M27V87OMX	18, 20	1 1/16-12	M27 X 2.0	32	15.5	18.0	32.5	43.2	27	•		
16M33V87OMX	25	1 5/16-12	M33 X 2.0	41	21.5	23.0	37.3	46.5	33	•		

For O-ring part number, see page I35.

Sleeve TX

Flare Tube End Sleeve For Metric Tubing

Part Number Information
TX - Sleeve

All dimensions are in millimeters

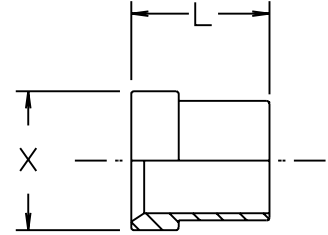

(3) TUBE FITTING PART #	TUBE O.D. (mm)	Fitting Dash Size	L (mm)	X (mm)	STANDARD MATERIAL FROM STOCK		
					S	SS	B
(1) TXS6	6	-4	10.4	9.6	•		
(1) 5 TX	8	-5	11.2	11.4	•		
TXS10	10	-6	12.7	12.7	•		
TXS12	12	-8	14.2	17.3	•		
TXS14	14	-10	16.8	20.3	•		
TXS15	15	-10	16.8	20.3	•		
(1) 10 TX	16	-10	16.8	20.3	•		
TXS18	18	-12	17.3	24.6	•		
(2) 20-12 TX	20	-12	17.3	24.6	•		
TXS22	22	-14	19.0	27.8	•		
TXS25	25	-16	19.8	31.0	•		
TXS28	28	-20	23.1	38.9	•		
TXS30	30	-20	23.1	38.9	•		
TXS32	32	-20	23.1	38.9	•		
TXS35	35	-24	28.4	45.2	•		
(1) 24 TX	38	-24	28.4	45.2	•		

- (1) Inch sleeve for use with metric tubing.
- (2) Use with 20-12 BTX.
- (3) "TXS" part number is for steel sleeve.
Specify "TXSS" for stainless steel sleeve.



Nut (Inch Hex) BTX

Flare tube end nut

SAE 070110

Part Number Information
BMTX - Nut

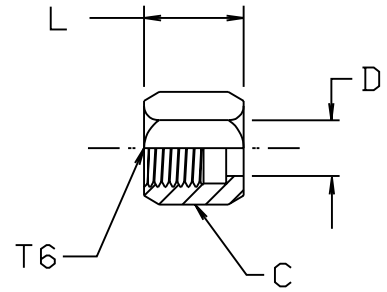

All dimensions are in millimeters

TUBE FITTING PART #	TUBE O.D. (mm)	T6 TUBE END UN/UNF-2B	C HEX (mm)	D (mm)	L (mm)	STANDARD MATERIAL FROM STOCK		
						S	SS	B
4 BTX	6	7/16-20	14	7.8	15.8	•	•	•
5 BTX	8	1/2-20	17	9.5	14.7	•	•	•
6 BTX	10	9/16-18	19	11.2	15.3	•	•	•
8 BTX	12	3/4-16	22	14.5	18.4	•	•	•
10 BTX	14, 15, 16	7/8-14	27	17.8	20.8	•	•	•
12 BTX	18	1 1/16-12	32	21.2	22.0	•	•	•
20-12 BTX	20	1 1/16-12	32	21.2	22.0	•	•	•
16 BTX	25	1 5/16-12	41	27.7	24.4	•	•	•
* 20 BTX	28, 30, 32	1 5/8-12	50	34.2	25.8	•	•	•
24 BTX	35, 38	1 7/8-12	60	41.0	29.7	•	•	•
32 BTX	42, 50	2 1/2-12	65	48.0	39.7	•	•	•

* Use with 20-12 TX.

BSPP

O-Ring & Retaining Ring

(For ISO 1179-1 / DIN 3852-2 Port)

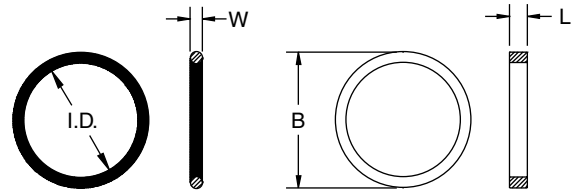

Part Number Information
Specify size and compound

Example: 2-113 N0552
3/8 RETAINING RING

All dimensions are in millimeters

BSPP THREAD SIZE	O-RING PART #	ID (mm)	W (mm)	STANDARD MATERIAL FROM STOCK		RETAINING RING PART #	B (mm)	L (mm)	STANDARD MATERIAL FROM STOCK	
				N0552	V0894				S	SS
1/8-28	5-585	7.97	1.78	•	•	1/8 Retaining Ring	14.96	1.45	•	
1/4-19	2-111	10.77	2.62	•	•	1/4 Retaining Ring	20.45	1.96	•	
3/8-19	2-113	13.94	2.62	•	•	3/8 Retaining Ring	23.95	1.96	•	
1/2-14	5-256	17.96	2.62	•	•	1/2 Retaining Ring	28.45	1.96	•	
3/4-14	2-119	23.47	2.62	•	•	3/4 Retaining Ring	34.44	2.64	•	
1-11	2-217	29.74	3.53	•	•	1 Retaining Ring	44.45	2.64	•	
1 1/4-11	2-222	37.69	3.53	•		1 1/4 Retaining Ring	52.45	2.64	•	
1 1/2-11	2-224	44.04	3.53	•		1 1/2 Retaining Ring	59.94	2.64	•	
2-11	2-228	63.80	3.53			2 Retaining Ring	72.80	2.64		

N0552 is the standard 90-durometer Nitrile (e.g., Buna-N).

V0894 is an optional 90-durometer fluorocarbon (e.g., Viton®).

Other compounds may be purchased from the Parker O-ring Division, phone (606) 269-2351.

See page A29 for O-ring Material Selection and data.



Metric O-Ring & Retaining Ring (For ISO 9974-1 / DIN 3852-1Port)

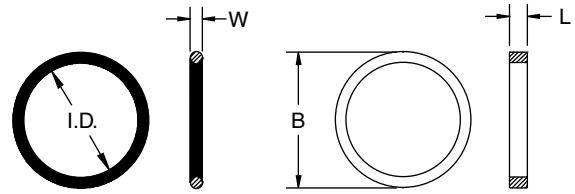

Part Number Information
Specify size and compound
Example: 2-012 N0552
M12RR

All dimensions are in millimeters

METRIC THREAD SIZE	O-RING PART #	ID (mm)	W (mm)	STANDARD MATERIAL FROM STOCK		RETAINING RING PART #	B (mm)	L (mm)	STANDARD MATERIAL FROM STOCK	
				N0552	V0894				S	SS
M8x1	3-902	6.07	1.63	•	•	M8RR	13.15	1.00	•	
M10x1	6-074	8.00	1.50	•	•	M10RR	14.75	1.00	•	
M12x1.5	2-012	9.25	1.78	•	•	M12RR	17.75	1.30	•	
M14x1.5	2-013	10.82	1.78	•	•	M14RR	19.75	1.30	•	
M16x1.5	3-907	13.46	2.08	•	•	M16RR	21.75	1.50	•	
M18x1.5	2-114	15.54	2.62	•	•	M18RR	23.75	2.00	•	
M20x1.5	2-017	17.17	1.78	•	•	M20RR	25.75	1.30	•	
M22x1.5	2-018	18.77	1.78	•	•	M22RR	27.75	1.30	•	
M24x1.5	2-019	20.35	1.78	•	•	M24RR	29.75	1.30	•	
M26x1.5	2-118	21.89	2.62	•	•	M26RR	31.75	2.00	•	
M27x2	2-119	23.47	2.62	•	•	M27RR	32.75	2.00	•	
M30x2	2-121	26.64	2.62	•	•	M30RR	36.32	2.00	•	
M33x2	2-122	28.24	2.62	•	•	M33RR	39.75	2.00	•	
M36x2	2-124	31.42	2.62	•	•	M36RR	42.75	2.00	•	
M42x2	2-128	37.77	2.62	•	•	M42RR	49.75	2.00	•	
M45x2	2-130	40.94	2.62	•	•	M45RR	52.75	2.00	•	
M48x2	2-132	44.12	2.62	•	•	M48RR	54.95	2.00	•	
M50x2	2-133	45.69	2.62	•	•	M50RR	56.31	2.00	•	

N0552 is the standard 90-durometer Nitrile (e.g., Buna-N).
V0894 is an optional 90-durometer fluoroelastomer (e.g., Viton®).
Other compounds may be purchased from the Parker O-ring Division, phone (606) 269-2351.
[See page A29](#) for O-ring Material Selection and data.

Conversion Adapters

There are many types of threads used throughout the world. This Section contains adapters with just a few of those many thread types including: NPT, NPTF, BSPT, BSPP, SAE UN/UNF, and Metric. All the threads in this section are made to industry specifications with conformance shown in [Table I10](#).

Thread	Standard
NPT	ANSI B1.20.1, FED-STD-H28/7
NPTF	SAE J476, ANSI B1.20.3, FED-STD-H28/8
BSPT	BS 21, ISO 7/1
BSPP	BS 2779, ISO 228/1
Metric	ISO 261, ANSI B1.13M, FED-STD-H28/21
UN/UNF*	ANSI B1.1, FED-STD-H28/2

*Class 2A or 2B

Table I10 — Thread Conformance Standards

The next few pages describe the application and assembly methods for the adapters using the various threads above.

Design and Construction

Shaped products (elbows, tees and crosses) are hot forged and machined, while straights are manufactured from cold drawn barstock. Where applicable, these products are made in conformance with the design criteria of the society of Automotive Engineers Standards, SAE J514, J530.

Standard material Specifications: The standard materials used in the manufacture of Industrial Pipe and Adapter fittings are shown in [Table I11](#).

Pipe Fittings, Adapters and Plugs	Steel		Stainless Steel		Brass	
	ASTM	Type	ASTM	Type	ASTM	Type
Forged Bodies	A576	1214/1215	A182	316	B124	CA377
Bar Stock Bodies	A108	12L14	A479	316	B16 B453	CA360 CA345

Table I11 — Standard Material Specifications for Industrial Pipe Fittings and Adapters

Note: Upon request, pipe fittings, adapters and plugs could be furnished in materials other than those shown in the materials specifications chart.

Parker Fluid Connector products made from steel and brass, for the most part, have NPTF threads. Stainless steel products may have NPT or slightly modified NPT threads to minimize the chance of galling on assembly.

Finish - Zinc with Yellow Chromate is used on all standard steel products. Stainless steel fittings are passivated.

NPT and NPTF Connections

How Tapered Pipe Threads Work

NPT and NPTF (Dryseal) tapered pipe threads feature a 60° flank angle and 1°47' taper, as shown in [Fig. I12](#).

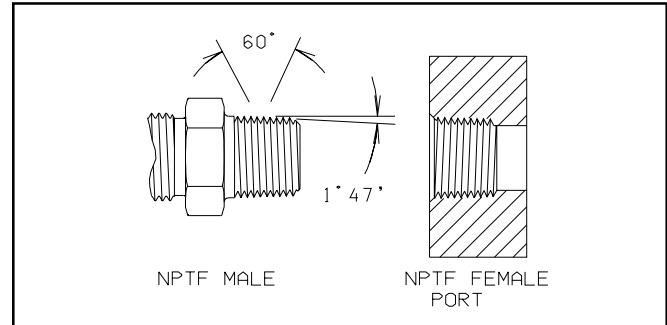

Fig. I12 — Dryseal American Standard Taper Pipe Thread, NPTF

How A Leak Free Joint Is Achieved

NPT threads, when assembled without a sealant, leave a spiral leak path at the crest-root junction as shown in [Fig. I13](#). To seal pressurized fluid, NPT threads need a suitable sealer.

NPTF threads (Dryseal), on the other hand, when assembled, do not leave such spiral leak path. This is because they have controlled truncation at the crest and root, ensuring metal to metal crest-root contact prior to, or just as the male-female thread flanks make contact as seen in [Fig. I14](#). Upon further tightening, the thread crests are flattened out until the flanks also make metal to metal contact as seen in [Fig. I15](#). Thus, theoretically at least, there is no passage left for the fluid to leak, provided all surfaces are flawless and dimensions exact. In the real world, however, this is not the case and a sealant/lubricant is necessary to achieve a leak free joint even with NPTF threads. The sealant/lubricant fills all imperfections in the surfaces affecting the seal and provides lubrication to ease assembly and minimize galling.

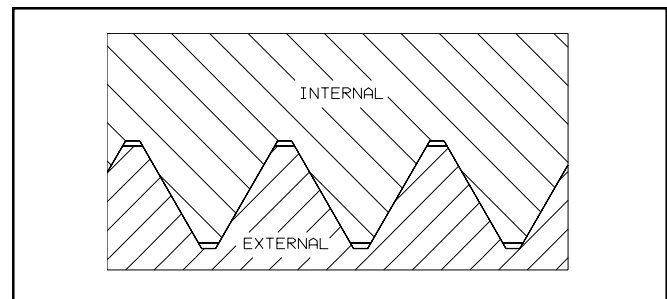

Fig. I13 — NPT: Wrench Tight-No Crest-Root Contact, Flank Contact Only

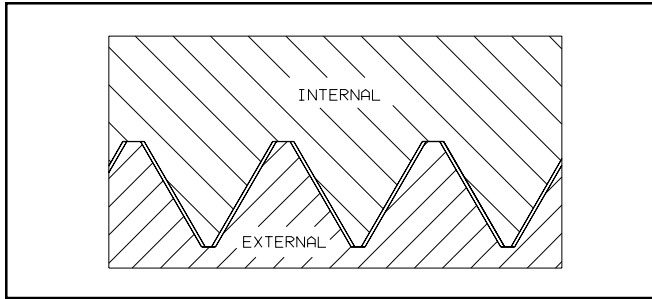

Fig. I14 — NPTF: Hand Tight-Crest to Root Contact

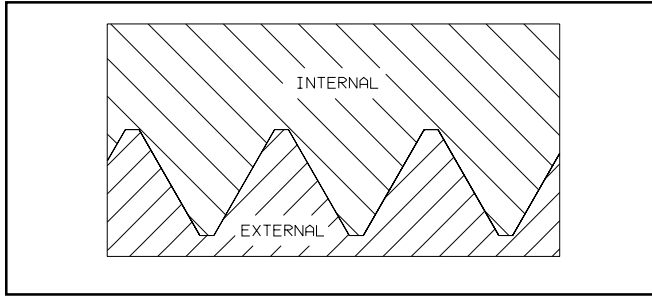

Fig. I15 — NPTF: Wrench Tight-Crest to Root and Flank Contact

It is easier to obtain a seal with NPTF threads than it is with NPT threads because of the metal to metal contact along the full thread profile. Therefore, they are preferred over NPT in high pressure hydraulic applications.

Type of Sealant/Lubricant

Please see [page A43](#) in the General Technical section.

Pressure Holding Capacity

Dryseal taper pipe threads have the highest strength of any commonly used port connection to withstand static pressure load (blow-off resistance). This pressure holding capacity depends mainly on the following factors:

- Strength of connectors and port materials.
- Total number of threads engaged.
- Quality of threads of the mating parts.

Extensive testing has been conducted by the Fluid Connector Divisions of Parker to determine the pressure at which failure occurred in the form of leakage or burst with pipe threaded (NPTF) joints. Tests were conducted on production parts made from low carbon steel forgings as well as barstock, using hardened steel test blocks for male threads and low carbon steel plugs for female threads.

Sealing of Pipe Threads

Pipe threads have very high pressure holding (blow-off resistance) capability. However, their ability to create and maintain seal in a dynamic (high cycle pulsating with attendant shocks and vibration) applications depends on many factors, including the following:

- Quality of threads (surface, form and dimensions) of both the port and the connector.
- Type and application of the sealant.
- Joint tightness.

- Port and connector material combination (difference in thermal expansion).
- Severity of application — amount and severity of vibration, shocks (hydraulic as well as mechanical) and thermal cycling involved.
- Procedure followed in positioning (orienting) shaped connectors.
- Sensitivity of female pipe threads in shaped connectors to over tightening.
- Number of times the joint is re-assembled and the extent to which proper procedure is followed.
- Clamping and routing.

The more of the above factors that are involved in making a connection, the greater is its propensity for leakage. Thus, the propensity for leakage of a pipe threaded joint can vary from extremely low to very high depending on its favorable/unfavorable mix of the above factors in an application.

Past experience has shown and extensive testing has confirmed that:

- Connectors with larger pipe threads have a higher tendency to leak than those with smaller ones. This is because larger threads have more chances for surface imperfections and dimensional inaccuracies; and, being heavier, they are more prone to handling damage. They probably don't always get tightened properly as they require larger wrench clearances and more effort.
- Connectors with female pipe threads have a higher tendency to leak than those with male pipe threads. This is because female pipe threads machined in connectors tend to expand under pressure spikes and repeated assembly, causing eventual loss of seal.
- Shaped connectors with pipe threads have a higher tendency to leak than straight ones because shapes are apt to see higher loosening moments (hose pull, accidental bumping, etc.) than straight ones. They are also more prone to handling damage than straight ones because the forgings are softer than the barstock. Brazed connectors are more susceptible to damage than forged ones due to their even softer (HRB 50-60) condition. Also, it is difficult to always tighten shapes with pipe threads to an optimum tightness level because of orientation requirements.

Thus, connectors with pipe threads, except for straight ones with 3/4-14 NPTF and smaller male pipe threads, have low reliability for leak free operation in dynamic applications. Therefore, where no leakage can be tolerated, SAE straight thread (SAE J1926/ISO 11926), SAE four bolt split flange (SAE J518/ISO 6162) and ISO 6149 port connections are recommended.

Recommended Working Pressures

Some manufactures rate their pipe threaded products very aggressively, i.e. they use one value for all products with pipe threads of a given size, based on burst/leakage tests with male threaded barstock parts. These are very misleading and can lead to leakage or even more serious problems.

We believe the correct way to rate the pipe threads is by taking into consideration the type of product (barstock or forged with male or female threads) and severity of the application.

Working pressures for pipe threaded ends of connectors are arrived at by applying a design factor, based on severity of application. The pressure tables are based on these factors.

Application Guidelines

As seen in the pressure tables, straight connectors with 3/4-14 NPTF and smaller male pipe threads have very high pressure holding capability and seal reliability when used in applications without make and break (such as maintenance) requirements. They are also well suited for low cycle non-pulsating applications with pressures in excess of 6,000 psi.

As noted earlier, connectors with pipe threads, except for straight connectors with 3/4-14 NPTF and smaller male pipe threads, have low reliability for leak free operation in dynamic applications. Therefore, they are not preferred where a leak free joint is required.

While a pipe thread connection can be disassembled and re-assembled in low pressure systems, it is not intended to be a make and break connection. When connectors are known to be disassembled and re-assembled repeatedly, pipe connections are not preferred for high pressure systems.

For the above applications, a port connection with an elastomeric seal, such as SAE straight thread port (SAE J1926/ISO 11979) or SAE four bolt split flange (SAE J518/ISO 6162) and ISO 6149 is recommended.

For application where sealants can't be used, consult the manufacturer.

Assembly of NPTF Port Connections

Please refer to [pages A43 and A44](#) in the General Technical section for recommended assembly procedures for the pipe thread products shown in this section.

Trouble Shooting Guide

Problem	Solution
There is no sealant used or sealant has worn thin.	Apply new sealant and re-tighten to specification.
Threads are galled.	Replace fitting and/or component.
Fitting screws in too far into the port.	Port opened up or cracked Replace component.
Threads are severely nicked.	Replace fitting.
Seals initially but vibrates loose after some time.	Replace with SAE straight thread port.

Table I13 — Industrial Pipe Fittings and Adapters Trouble Shooting Hints

SAE Straight Thread Adapters

How SAE Adapters Work

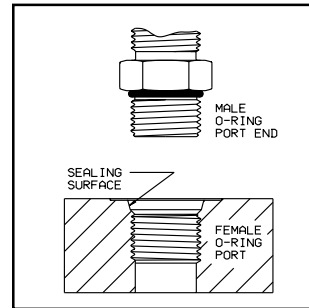

Fig. I16 — SAE Straight Thread O-ring Port

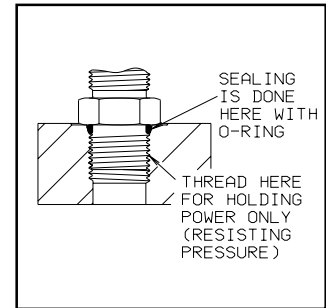

Fig. I17 — SAE Straight Thread O-ring Port Assembly

Parker fittings incorporating SAE Straight Thread O-Ring port studs shown in this section are for connection with the SAE Straight Thread port (SAE J1926-1 / ISO 11926-1) as shown on [page A19](#) in the General Technical section. When properly assembled, they provide the best leak-free port connection available.

Basic port machining dimensions for this industry standard port are given on [page A19](#) in the General Technical Section. For counterbore and thread tapping tools for this port see [page N50](#) in the Tube Fabrication Equipment section.

Assembly of SAE Straight Thread Port Connections

Please see [page A40 through A42](#) in the General Technical section for assembly procedures and torque values.

Trouble Shooting Guide — SAE Straight Thread

Problem	Solution
Leakage from port	O-Ring missing or torn. Replace with new O-Ring and retighten to appropriate specification.
Leakage from port	Fitting not tightened properly, tighten to appropriate specification.
Leakage from port	Adjustable stud not assembled properly, repeat with appropriate assembly procedure as outlined in General Technical Section, Section A. Tighten to appropriate torque specification.
Fitting vibrates loose	Re-evaluate system: clamping, routing, stressed joint, etc.
Threads damaged	Replace fitting and/or component.

Table I17 — SAE Straight Thread Trouble Shooting Hints

Features, Advantages and Benefits — SAE Straight Thread Connections

1. **Elastomeric Seal** — SAE Straight Thread O-Ring connections offer a high seal reliability, especially in dynamic and shock loading applications. The O-Ring seal offers a high tolerance to minor surface imperfections and damage.
2. **Infinite Positioning of Shaped Fittings** — Due to the design of shaped fittings incorporating adjustable SAE Straight Thread connections, they allow for infinite positioning of the port end. Aligning for tube and hose connections is much easier as compared to tapered pipe threads/ports. Female and male thread damage is diminished as well because SAE Straight Threads do not incorporate the metal to metal thread sealing of tapered threads.
3. **Reusability** — Since the sealing and mechanical holding functions are separated, the SAE Straight Thread male studs can be re-used many times simply by changing the O-ring.

BSPT/BSPP Port Connections

How BSP Thread Fittings Work

In Europe, Japan and many other former Commonwealth nations the British Standard Pipe thread form, BSP, is still used extensively to connect pipes and components in hydraulic systems. The BSP thread is offered in a straight (parallel) form known as BSPP and a tapered form known as BSPT. These threads feature a 55° flank angle and the British Whitworth thread profile as shown in [Figs. I18 and I19](#).

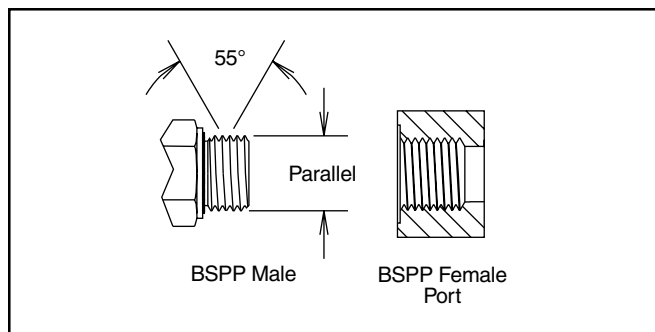

Fig. I18 — British Standard Pipe, Parallel — BSPP

BSPT Threads seal identical to NPT/NPTF thread forms.

Fittings in this section that use BSPT thread have the same benefits and short comings of NPT threads. Therefore, these fittings will require the same preparation and assembly techniques that NPT fittings require. The BSPT thread is designed to thread into and seal in a female BSPT or BSPP port.

Fittings in this section with male BSPP threads use a primary sealing method of an O-ring and retaining ring. Additional sealing methods such as a cutting face or an EOlastic seal are also available on other fittings within the catalog. These BSPP fittings are all designed to thread into a female BSPP port, however, the seal is created with one of the aforementioned sealing methods, not with the threads. It is also important to note that with these BSPP threaded connection, the seal occurs on the port surface or spotface, not in an O-ring gland or chamfer as SAE and ISO-6149 straight thread do. A detail of the BSPP port is shown on [page A21](#).

Assembly of BSP Thread Connections

Fittings with BSPT thread should be prepared and assembled using the assembly methods for NPT/NPTF threads shown on [pages A43 and A44](#) in the General Tehnical section.

Fittings with BSPP threads require a BSPP port conforming to the dimensions shown on [page A21](#) to seal properly. The General Technical Section, Section A, gives the proper assembly torques for this port connection on [page A45](#).

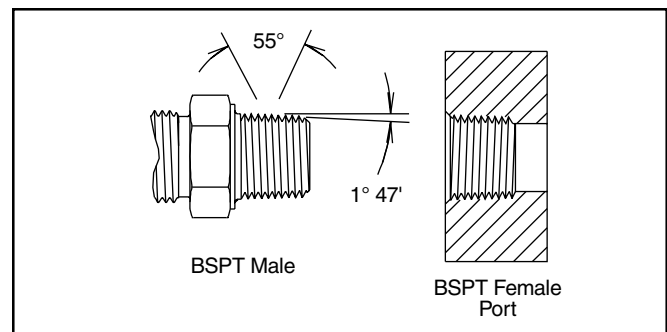

Fig. I19 — British Standard Pipe, Tapered — BSPT

Metric Port Connections

How Metric Port Connections Work

Metric Parallel Thread – ISO 9974 / (DIN 3852, Part 1)

In Europe, primarily in Germany, the traditional metric parallel thread form is still used extensively to connect components in hydraulic systems. This metric thread is designed to thread into and seal in a female Metric parallel port conforming to ISO-9974-1 (DIN-3852, Part 1). Fittings in this section with male metric threads will utilize a primary sealing method of an O-ring and retaining ring. Additional sealing methods such as a cutting face or an EOlastic seal are also available on other fittings within the catalog. Sealing is accommodated with one of the aforementioned sealing methods, not with the threads. It is also important to note that with these male metric threads, the seal occurs on the top face (spotface) of the port, not in an O-ring gland or chamfer as in SAE and ISO-6149 straight threads. A detail of this metric port is shown on [page A22](#).

Assembly of Metric Parallel Thread Port Connections

Please see [page A45](#) in the General Technical section for recommended assembly torques for this port connection.

ISO 6149

To minimize further proliferation of additional port thread styles, the International Standards Organization Technical Committee 131 has completed the development of a world standard leak-free port connection. It is recommended that this port, ISO 6149-1, be specified in all new hydraulic fluid power applications. Parker and other fluid connector manufacturers are expanding product offering to incorporate the ISO 6149 male studs as a standard on many tube fitting products. Parker offers the ISO 6149 male stud end on several tube fitting products including: Seal-Lok, EO, EO-2, Pipe, Plugs, etc.

This port, utilizes metric parallel threads for mechanical holding power and a sealing method similar to the proven SAE Straight Thread O-ring port. A detail of this metric port is shown on [page A18](#).

Assembly of ISO 6149 Port Connections

The assembly procedure for the straight or adjustable versions of ISO 6149 male studs mirror that of SAE Straight Thread O-Ring male studs. This assembly procedure can be found on [page A42](#) of the General Technical Section and recommended assembly torques are given on [page A45](#).

These recommended working pressures represent the capability of the subject fitting. Nevertheless, in some instances, the wall thickness or type of tubing, hose, or hose connector, assembled to the fitting may dictate the maximum pressure to which the assembly should be exposed. It is strongly suggested that these fitting working pressure charts be used in conjunction with appropriate pressure charts for tubing or hose during the fitting selection process.

Refer to the definition of pressure rated static and pressure rated dynamic. The following values are based on a minimum design factor of 4:1 for dynamic and 3:1 for static applications.

Pressure, Rated Static – The maximum pressure that a pressure containing envelope is capable of sustaining in an application not exceeding 30,000 operating cycles in a system free of pressure surges, shocks, vibration, and temperature excursions.

Pressure, Rated Dynamic – The maximum fluctuating pressure load that a pressure containing envelope is capable of sustaining for a minimum of one million operation cycles without failure.

		F3HG			GG44M		
		STATIC			DYNAMIC		
SIZE	STEEL	SS	BRASS	STEEL	SS	BRASS	
1/8	10000	12000	6500	6000	7200	3900	
1/4 X 1/8	9500	11400	6175	6000	7200	3900	
1/4	9500	11400	6175	6000	7200	3900	
3/8 X 1/8	8000	9600	5200	6000	7200	3900	
3/8 X 1/4	8000	9600	5200	6000	7200	3900	
3/8	8000	9600	5200	6000	7200	3900	
1/2 X 1/8	6500	7800	4225	5000	6000	3250	
1/2 X 1/4	6500	7800	4225	5000	6000	3250	
1/2 X 3/8	6500	7800	4225	5000	6000	3250	
1/2	6500	7800	4225	5000	6000	3250	
3/4 X 1/4	5500	6600	3575	4000	4800	2600	
3/4 X 3/8	5500	6600	3575	4000	4800	2600	
3/4 X 1/2	5500	6600	3575	4000	4800	2600	
3/4	5500	6600	3575	4000	4800	2600	
1 X 1/4	4000	4800	2600	3000	3600	1950	
1 X 3/8	4000	4800	2600	3000	3600	1950	
1 X 1/2	4000	4800	2600	3000	3600	1950	
1 X 3/4	4000	4800	2600	3000	3600	1950	
1	4000	4800	2600	3000	3600	1950	
1 1/4 X 3/4	3000	3600	1950	2500	3000	1625	
1 1/4 X 1	3000	3600	1950	2500	3000	1625	
1 1/4	3000	3600	1950	2500	3000	1625	
1 1/2 X 1	3000	3600	1950	2000	2400	1300	
1 1/2 X 1 1/4	3000	3600	1950	2000	2400	1300	
1 1/2	3000	3600	1950	2000	2400	1300	
2 X 1 1/2	3000	3600	1950	2000	2400	1300	
2	3000	3600	1950	2000	2400	1300	

		F80HG			
		STATIC		DYNAMIC	
SIZE	STEEL	SS	STEEL	SS	
M10-1/8	8000	9600	5000	6000	
M12-1/4	8000	9600	5000	6000	
M14-1/4	8000	9600	5000	6000	
M16-3/8	8000	9600	5000	6000	
M16-1/2	6500	7800	5000	6000	
M18-3/8	8000	9600	5000	6000	
M18-1/2	6500	7800	5000	6000	
M22-1/2	4500	5400	3500	4200	
M27-3/4	4500	5400	3500	4200	
M33-1	4000	4800	3000	3600	

		FHG5			
		STATIC		DYNAMIC	
SIZE	STEEL	SS	STEEL	SS	
1/4-6	6000	7200	4500	5400	
3/8-8	5000	6000	4000	4800	
1/2-10	4000	4800	3000	3600	

		FF33M					
		STATIC			DYNAMIC		
SIZE	STEEL	SS	BRASS	STEEL	SS	BRASS	
1/16	10000	12000	6500	6000	7200	3900	
1/8	10000	12000	6500	6000	7200	3900	
1/4 X 1/8	10000	12000	6500	6000	7200	3900	
1/4	10000	12000	6500	6000	7200	3900	
3/8 X 1/8	10000	12000	6500	6000	7200	3900	
3/8 X 1/4	10000	12000	6500	6000	7200	3900	
3/8	10000	12000	6500	6000	7200	3900	
1/2 X 1/4	10000	12000	6500	6000	7200	3900	
1/2 X 3/8	10000	12000	6500	6000	7200	3900	
1/2	10000	12000	6500	6000	7200	3900	
3/4 X 1/2	10000	12000	6500	6000	7200	3900	
3/4	10000	12000	6500	6000	7200	3900	
1	9000	10800	5850	6000	7200	3900	
1 1/4 X 1	6500	7800	4225	5000	6000	3250	
1 1/4	6500	7800	4225	5000	6000	3250	
1 1/2	4000	4800	2600	3000	3600	1950	
2	3000	3600	1950	2500	3000	1625	

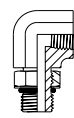
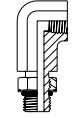
		 AOEG*			 AOE4G*		
		STATIC			DYNAMIC		
SIZE	STEEL	SS	BRASS	STEEL	SS	BRASS	
6 - 1/4	6000	6000	3900	5000	5000	3250	
8 - 1/4	6000	6000	3900	5000	5000	3250	
8 - 3/8	6000	6000	3900	4500	4500	2925	
8 - 1/2	4000	4000	2600	3000	3000	1950	
10 - 1/4	5500	5500	3575	4500	4500	2925	
10 - 3/8	5500	5500	3575	4500	4500	2925	
10 - 1/2	4000	4000	2600	3000	3000	1950	
10 - 3/4	4000	4000	2600	3000	3000	1950	
12 - 1/2	4000	4000	2600	3000	3000	1950	
12 - 3/4	4000	4000	2600	3000	3000	1950	
14 - 1/2	4000	4000	2600	3000	3000	1950	
14 - 3/4	4000	4000	2600	3000	3000	1950	
16 - 1/2	4000	4000	2600	3000	3000	1950	
16 - 3/4	4000	4000	2600	3000	3000	1950	
16 - 1	2250	2250	1463	1750	1750	1138	
20 - 1	2250	2250	1463	1750	1750	1138	
20 - 1 1/4	2000	2000	1300	1500	1500	975	
24 - 1	2250	2250	1463	1750	1750	1138	
24 - 1 1/2	2000	2000	1300	1500	1500	975	
32 - 1	2000	2000	1300	1500	1500	975	
32 - 1 1/2	2000	2000	1300	1500	1500	975	
32 - 2	1250	1250	813	1000	1000	650	

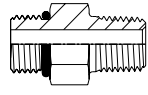
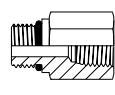
		 F50F			 F50G		
		STATIC			DYNAMIC		
SIZE	STEEL	SS	BRASS	STEEL	SS	BRASS	
4 - 1/8	8000	9600	5200	6000	6000	3900	
4 - 1/4	8000	9600	5200	6000	6000	3900	
6 - 1/4	8000	9600	5200	6000	6000	3900	
6 - 3/8	8000	9600	5200	6000	6000	3900	
6 - 1/2	6500	7800	4225	5000	6000	3250	
8 - 1/8	8000	9600	5200	6000	6000	3900	
8 - 1/4	8000	9600	5200	6000	6000	3900	
8 - 3/8	8000	9600	5200	6000	6000	3900	
8 - 1/2	6500	7800	4225	5000	6000	3250	
10 - 1/4	7500	9000	4875	5500	6000	3575	
10 - 3/8	7500	9000	4875	5500	6000	3575	
10 - 1/2	6500	7800	4225	5000	6000	3250	
10 - 3/4	5500	6600	3575	4000	4800	2600	
12 - 1/4	6500	7800	4225	5000	6000	3250	
12 - 3/8	6500	7800	4225	5000	6000	3250	
12 - 1/2	6500	7800	4225	5000	6000	3250	
12 - 3/4	5500	6600	3575	4000	4800	2600	
14 - 1/2	5500	6600	3575	4000	4800	2600	
14 - 3/4	5500	6600	3575	4000	4800	2600	
16 - 1/2	5500	6600	3575	4000	4800	2600	
16 - 3/4	5500	6600	3575	4000	4800	2600	
16 - 1	4000	4800	2600	3000	3600	1950	
20 - 1	4000	4800	2600	3000	3600	1950	
20 - 1 1/4	3000	3600	1950	2500	3000	1625	
20 - 1 1/2	3000	3600	1950	2500	3000	1625	
24 - 1	3500	4200	2275	2500	3000	1625	
24 - 1 1/4	3000	3600	1950	2000	2400	1300	
24 - 1 1/2	3000	3600	1950	2000	2400	1300	
32 - 1	2500	3000	1625	2000	2400	1300	
32 - 1 1/2	2500	3000	1625	2000	2400	1300	
32 - 2	2500	3000	1625	2000	2400	1300	

* Shaped connectors (elbows, tees and crosses) with pipe threads have low reliability for leak free operation in dynamic systems. For total leak free reliability in such systems, connectors with o-ring sealing such as SAE straight thread or SAE four bolt split flange are recommended.

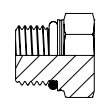
		 P87OMN					
		STATIC			DYNAMIC		
SIZE	STEEL	SS	BRASS	STEEL	SS	BRASS	
M10	10500	12600	6825	8000	9600	5200	
M12	12000	14400	7800	9000	10800	5850	
M14	12000	14400	7800	9000	10800	5850	
M16	12000	14400	7800	9000	10800	5850	
M18	12000	14400	7800	9000	10800	5850	
M22	8000	9600	5200	6000	7200	3900	
M27	8000	9600	5200	6000	7200	3900	
M33	8000	9600	5200	6000	7200	3900	
M42	5500	6600	3575	4000	4800	2600	

		 F40HG					
		STATIC			DYNAMIC		
SIZE	STEEL	SS	BRASS	STEEL	SS	BRASS	
1/8 x 1/8	8000	9600	5200	5000	6000	3250	
1/4 x 1/4	8000	9600	5200	5000	6000	3250	
3/8 x 3/8	8000	9600	5200	5000	6000	3250	
1/2 x 1/2	4500	5400	2925	3500	4200	2275	
3/4 x 3/4	4500	5400	2925	3500	4200	2275	
1 x 1	4500	5400	2925	3500	4200	2275	

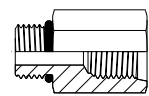
		 F50G5					
		STATIC			DYNAMIC		
SIZE	STEEL	SS	BRASS	STEEL	SS	BRASS	
4-5	6000	7200	3900	4500	5400	2925	
4-6	6000	7200	3900	4500	5400	2925	
6-4	6000	7200	3900	4500	5400	2925	
6-8	5000	6000	3250	4000	4800	2600	
8-6	6000	7200	3900	4500	5400	2925	
8-10	4000	4800	2600	3000	3600	1950	
10-6	6000	7200	3900	5000	6000	3250	
10-8	5000	6000	3250	4000	4800	2600	
10-12	4500	5400	2925	3500	4200	2275	
12-8	6000	7200	3900	4500	5400	2925	
12-10	4000	4800	2600	3000	3600	1950	
12-14	3000	3600	1950	2000	2400	1300	
12-16	3000	3600	1950	2000	2400	1300	
14-10	5000	6000	3250	4000	4800	2600	
14-12	4500	5400	2925	3500	4200	2275	
16-8	6000	7200	3900	5000	6000	3250	
16-12	4500	5400	2925	3500	4200	2275	
16-20	3500	4200	2275	2500	3000	1625	
20-10	4000	4800	2600	3000	3600	1950	
20-12	4000	4800	2600	3000	3600	1950	
20-16	3000	3600	1950	2000	2400	1300	
20-24	2000	2400	1300	1500	1800	975	
24-12	3000	3600	1950	2000	2400	1300	
24-16	3000	3600	1950	2000	2400	1300	
24-20	3000	3600	1950	2000	2400	1300	
32-24	2000	2400	1300	1500	1800	975	

For pressure ratings for adapters not shown, please contact the Tube Fittings Division.

How to Order Industrial Pipe Fittings and Adapters

Nomenclature

Pipe fitting part numbers are constructed from symbols that identify the size and style of the fitting and material used.

Sizes

2 (1/8") through 32 (2"). Tube sizes are determined by the number of sixteenths of an inch in the tube O.D.

Materials

Type 316 Stainless Steel, Steel and Brass. Pipe fittings for special applications can be furnished in almost any material suitable for machining.

Example

Fitting needed — (Pipe fitting) — Steel Male Connector for 1/4" Female Port to 1/8" Female Port.

Part number: 1/4 x 1/8 FF

<u>1/4</u>	<u>X</u>	<u>1/8</u>	<u>FF</u>	—	<u>S</u>	<u>BP</u>
1/4" male pipe thread		1/8" male pipe thread	pipe nipple		Material steel	Bulk Pack (where avail.)

Crosses and Tees

For tees — first size the run (1 to 2) and then the branch (3). For crosses — first size the run (1 to 2) and then the branch (3 to 4).

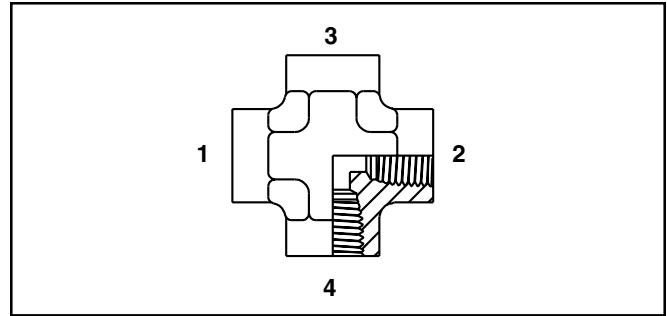

Special Fittings

If design or configuration is questionable please provide a detailed sketch, drawing or sample part to [the Tube Fittings Division](#).

Conversion Adapter F3HG5

Male BSPT / Female SAE straight thread

All dimensions are in inches

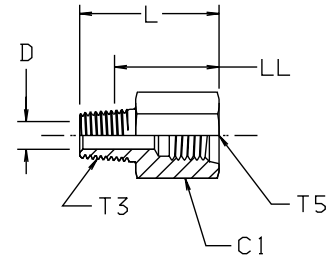

TUBE FITTING PART #	T3 PORT THD BSPT	T5 PORT THD UN/UNF-2B	C1 HEX (inch)	D DRILL (inch)	L (inch)	LL AFTER ASSY (inch)	STANDARD MATERIAL FROM STOCK		
							S	SS	B
1/8-4F3HG5	1/8-28	7/16-20	11/16	0.188	1.09	0.86	•		
1/8-5F3HG5	1/8-28	1/2-20	3/4	0.188	1.09	0.86	•		
1/4-6F3HG5	1/4-19	9/16-18	13/16	0.281	1.36	1.02	•		
3/8-8F3HG5	3/8-19	3/4-16	1	0.406	1.45	1.09	•		
1/2-10F3HG5	1/2-14	7/8-14	1 1/8	0.531	1.78	1.32	•		
3/4-12F3HG5	3/4-14	1 1/16-12	1 3/8	0.719	1.92	1.40	•		
1-16F3HG5	1-11	1 5/16-12	1 5/8	0.938	2.13	1.54	•		

Conversion Adapter F3HG

Male BSPT / Female NPTF*

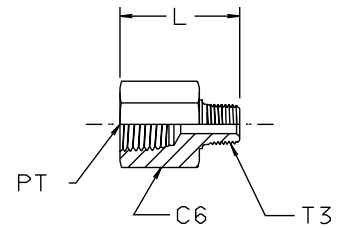

TUBE FITTING PART #	PT FEMALE NPT	T3 MALE BSPT	C6 HEX (inch)	L (mm)	STANDARD MATERIAL FROM STOCK		
					S	SS	B
1/8 x 1/8F3HG	1/8	1/8	9/16	25	•		
1/4 x 1/4F3HG	1/4	1/4	3/4	34	•		
3/8 x 3/8F3HG	3/8	3/8	7/8	35	•		
1/2 x 1/2F3HG	1/2	1/2	1 1/8	47	•		
3/4 x 3/4F3HG	3/4	3/4	1 3/8	47	•		
1 x 1F3HG	1	1	1 5/8	58	•		

*Modified for stainless steel.



Conversion Adapter – BSPP to SAE F4OHG5

For ISO 1179-1 / DIN 3852-2 Port
Male BSPP / Female SAE straight thread

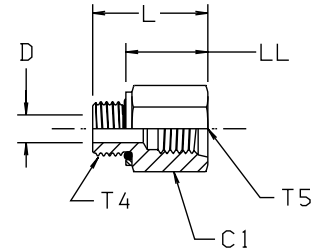

F4HG5 - Body only
F4OHG5 - Assembled with O-ring and retaining ring

All dimensions are in inches

TUBE FITTING PART #	T4 PORT THD BSPP	T5 PORT THD UN/UNF-2B	C1 HEX (inch)	D DRILL (inch)	L (inch)	LL AFTER ASSY (inch)	STANDARD MATERIAL FROM STOCK		
							S	SS	B
1/8-4F4OHG5	1/8-28	7/16-20	11/16	0.172	1.00	0.75	•		
1/4-6F4OHG5	1/4-19	9/16-18	13/16	0.297	1.25	0.89	•		
3/8-6F4OHG5	3/8-19	9/16-18	7/8	0.297	1.25	0.89	•		
3/8-8F4OHG5	3/8-19	3/4-16	1	0.391	1.33	0.97	•		
1/2-10F4OHG5	1/2-14	7/8-14	1 1/8	0.484	1.60	1.14	•		
3/4-12F4OHG5	3/4-14	1 1/16-12	1 3/8	0.609	1.74	1.28	•		
1-16F4OHG5	1-11	1 5/16-12	1 3/4	0.844	1.92	1.33	•		
1 1/4-20F4OHG5	1 1/4-11	1 5/8-12	2	1.078	1.95	1.36	•		

Replacement O-rings and Retaining Rings can be found on [page I63](#).

Conversion Adapter – BSPP to NPTF* F4OHG

For ISO 1179-1 / DIN 3852-2 Port
Male BSPP / Female NPTF

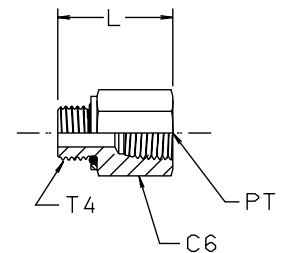

Part Number Information
F4HG - Body only
F4OHG - Assembled with O-ring and retaining ring

TUBE FITTING PART #	PT FEMALE NPT	T4 MALE BSPP	C6 HEX (inch)	L (mm)	STANDARD MATERIAL FROM STOCK		
					S	SS	B
1/8 x 1/8F4OHG	1/8	1/8	5/8	24	•		
1/4 x 1/4F4OHG	1/4	1/4	3/4	32	•		
3/8 x 3/8F4OHG	3/8	3/8	7/8	33	•		
1/2 x 1/2F4OHG	1/2	1/2	1 1/8	43	•		
3/4 x 3/4F4OHG	3/4	3/4	1 3/8	43	•		
1 x 1F4OHG	1	1	1 5/8	52	•		

Replacement O-rings and Retaining Rings can be found on [page I63](#).

*Modified for stainless steel.

Conversion Adapter – Metric to SAE F8OHG5

For ISO 9974 / DIN 3852-1 Port
Male metric / Female SAE straight thread

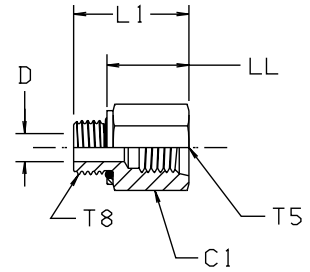

Part Number Information
F8HG5 - Body only
F8OHG5 - Assembled with O-ring and retaining ring

All dimensions are in inches

TUBE FITTING PART #	T5 PORT THD UN/UNF-2B	T8 PORT THD METRIC STR	C1 HEX (inch)	D	L1 (inch)	LL (inch)	STANDARD MATERIAL FROM STOCK		
							S	SS	B
M10-4F8OHG5	7/16-20	M10x1	11/16	0.157	1.06	0.77	•		
M10-6F8OHG5	9/16-18	M10X1	7/8	0.157	1.07	0.78	•		
M14-6F8OHG5	9/16-18	M14x1.5	13/16	0.276	1.19	0.89	•		
M16-8F8OHG5	3/4-16	M16x1.5	1	0.354	1.31	0.95	•		
M18-8F8OHG5	3/4-16	M18X1.5	1	0.433	1.38	0.96	•		
M22-10F8OHG5	7/8-14	M22x1.5	1 1/8	0.512	1.50	1.04	•		
M27-12F8OHG5	1 1/16-12	M27x2	1 1/4	0.630	1.88	1.33	•		
M33-16F8OHG5	1 5/16-12	M33x2	1 5/8	0.866	1.91	1.36	•		
M42-20F8OHG5	1 5/8-12	M42x2	2	1.102	1.91	1.34	•		

Replacement O-rings and Retaining Rings can be found on [page I64](#).

Conversion Adapter – Metric to NPTF* F8OHG

For ISO 9974 / DIN 3852-1 Port
Male metric / Female pipe thread

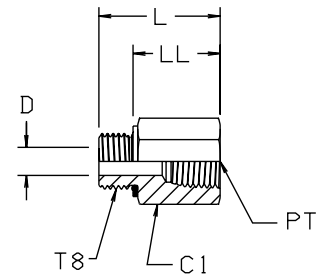

Part Number Information
F8HG - Body only
F8OHG - Assembled with O-ring and retaining ring

All dimensions are in inches

TUBE FITTING PART #	PT NPTF	T8 PORT THD METRIC STR	C1 HEX (inch)	D DRILL (inch)	L (inch)	LL (inch)	STANDARD MATERIAL FROM STOCK		
							S	SS	B
M10-1/8F8OHG	1/8-27	M10X1.0	9/16	0.157	0.99	0.64	•		
M12-1/4F8OHG	1/4-18	M12X1.5	3/4	0.196	1.24	0.85	•		
M14-1/4F8OHG	1/4-18	M14X1.5	3/4	0.281	1.24	0.85	•		
M16-3/8F8OHG	3/8-18	M16X1.5	7/8	0.354	1.36	0.91	•		
M16-1/2F8OHG	1/2-14	M16X1.5	1 1/8	0.354	1.58	1.13	•		
M18-3/8F8OHG	3/8-18	M18X1.5	15/16	0.433	1.42	0.91	•		
M18-1/2F8OHG	1/2-18	M18X1.5	1 1/8	0.433	1.67	1.16	•		
M22-1/2F8OHG	1/2-14	M22X1.5	1 1/8	0.512	1.68	1.10	•		
M27-3/4F8OHG	3/4-14	M27X2.0	1 3/8	0.630	1.87	1.20	•		
M33-1F8OHG	1-11 1/2	M33X2.0	1 5/8	0.866	2.11	1.44	•		

Replacement O-rings and Retaining Rings can be found on [page I64](#).

*Modified for stainless steel.

Female Straight Thread Adapter FHG5

Male Pipe / Female SAE Straight Thread

All dimensions are in inches

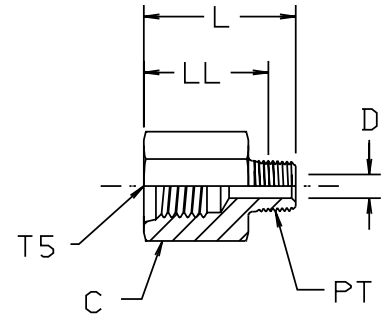

TUBE FITTING PART #	HOSE FITTING PART #	PT PORT THD NPTF	T5 PORT THD UN/UNF-2A	C HEX (inch)	D DRILL (inch)	L (inch)	LL AFTER ASSY (inch)	STANDARD MATERIAL FROM STOCK		
								S	SS	B
1/8-4 FHG5	0110-2-4	1/8-27	7/16-20	11/16	0.187	1.06	0.83	•		
1/8-5 FHG5	0110-2-5	1/8-27	1/2-20	3/4	0.187	1.09	0.86	•		
1/4-6 FHG5	0110-4-6	1/4-18	9/16-18	3/4	0.281	1.36	1.02	•		
3/8-8 FHG5	0110-6-8	3/8-18	3/4-16	1	0.391	1.50	1.15	•		
1/2-10 FHG5	0110-8-10	1/2-14	7/8-14	1 1/4	0.484	1.75	1.29	•		
3/4-8 FHG5	0110-12-8	3/4-14	3/4-16	1 1/8	0.672	1.13	0.65	•		

*Modified for stainless steel.

Female Pipe Elbow AOEG

Straight thread O-ring / Female pipe thread

Part Number Information
AEG - Body only
AOEG - Assembled with O-ring

All dimensions are in inches

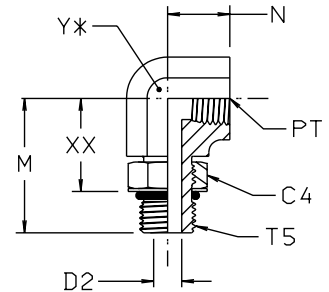

*Y—ACROSS WRENCH FLATS

TUBE FITTING PART #	HOSE FITTING PART #	PT PORT THD NPTF	T5 PORT THD UN/UNF-2A	C4 HEX (inch)	D2 DRILL	M (inch)	N (inch)	XX AFTER ASSY (inch)	Y (inch)	STANDARD MATERIAL FROM STOCK		
										S	SS	B
6-1/4 AOEG	2502-6-4	1/4-18	9/16-18	11/16	0.297	1.34	0.63	0.91	3/4	•		
8-3/8 AOEG	2502-8-6	3/8-18	3/4-16	7/8	0.391	1.47	0.63	0.98	7/8	•		
10-1/2 AOEG	2502-10-8	1/2-14	7/8-14	1	0.484	1.81	0.75	1.25	1 1/16	•		
12-3/4 AOEG	2502-12-12	3/4-14	1 1/16-12	1 1/4	0.609	2.00	0.81	1.35	1 5/16	•		
16-1 AOEG	2502-16-16	1-11 1/2	1 5/16-12	1 1/2	0.844	2.25	1.00	1.60	1 5/8	•		

Male Pipe Adapter F5OF

Male straight thread O-ring / Male NPTF*

Part Number Information
F5F - Body only
F5OF - Assembled with O-ring

All dimensions are in inches

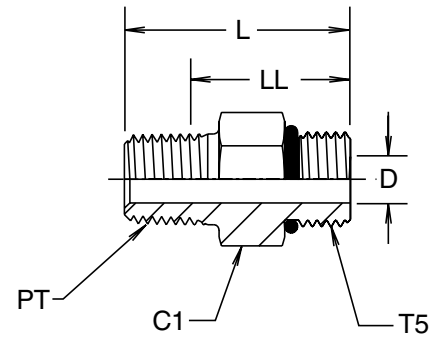

TUBE FITTING PART #	PT PORT THD NPTF	T5 PORT THD UN/UNF-2A	C1 HEX (inch)	D DRILL (inch)	L1 (inch)	LL (inch)	STANDARD MATERIAL FROM STOCK		
							S	SS	B
4-1/8 F5OF	1/8-27	7/16-20	9/16	0.172	1.00	0.64	•	•	
4-1/4 F5OF	1/4-18	7/16-20	9/16	0.172	1.20	0.81		•	
5-1/4 F5OF	1/4-18	1/2-20	5/8	0.234	1.20	0.81		•	
6-1/4 F5OF	1/4-18	9/16-18	11/16	0.297	1.25	0.86	•	•	
6-3/8 F5OF	3/8-18	9/16-18	11/16	0.297	1.34	0.95	•	•	
8-3/8 F5OF	3/8-18	3/4-16	7/8	0.391	1.36	0.92	•	•	
8-1/2 F5OF	1/2-14	3/4-16	7/8	0.391	1.53	1.09	•	•	
10-1/2 F5OF	1/2-14	7/8-14	1	0.484	1.59	1.09	•	•	
12-3/4 F5OF	3/4-14	1 1/16-12	1 1/4	0.656	1.80	1.21	•	•	
16-3/4 F5OF	3/4-14	1 5/16-12	1 1/2	0.719	1.78	1.19		•	
16-1 F5OF	1-11 1/2	1 5/16-12	1 1/2	0.875	1.98	1.39	•	•	
20-1 1/4 F5OF	1 1/4-11 1/2	1 5/8-12	1 7/8	1.078	2.02	1.43	•	•	

*Modified for stainless steel.

Extra Long Female Pipe Elbow AOE4G

Straight thread O-ring / Female pipe thread

Part Number Information
AE4G- Body only
AOE4G - Assembled with O-ring

All dimensions are in inches

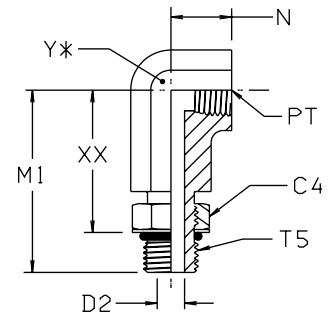

*Y—ACROSS WRENCH FLATS

TUBE FITTING PART #	HOSE FITTING PART #	PT PORT THD NPTF	T5 PORT THD UN/UNF-2A	C4 HEX (inch)	D2 DRILL	M1 (inch)	N (inch)	XX AFTER ASSY (inch)	Y (inch)	STANDARD MATERIAL FROM STOCK		
										S	SS	B
8-3/8 AE4OG	5502-8-6	3/8-18	3/4-16	7/8	0.391	2.94	0.63	2.45	7/8	•		
10-1/2 AE4OG	5502-10-8	1/2-14	7/8-14	1	0.484	3.56	0.75	3.00	1 1/16	•		
12-3/4 AE4OG	5502-12-12	3/4-14	1 1/16-12	1 1/4	0.609	4.06	0.81	3.41	1 5/16	•		
16-1 AE4OG	5502-16-16	1-11 1/2	1 5/16-12	1 1/2	0.844	4.63	1.00	3.98	1 5/8	•		

Female Pipe Adapter F50G

Male Straight thread O-ring / Female pipe thread

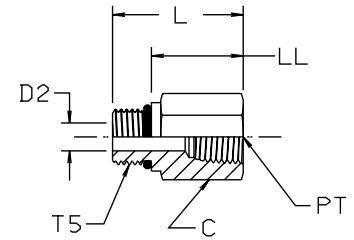

Part Number Information
F5G - Body only
F50G - Assembled with O-ring

All dimensions are in inches

TUBE FITTING PART #	PT PORT THD NPTF	T5 PORT THD UN/UNF-2A	C HEX (inch)	D2 DRILL	L (inch)	LL AFTER ASSY (inch)	STANDARD MATERIAL FROM STOCK		
							S	SS	B
2-1/8 F50G	1/8-27	5/16-24	9/16	0.094	0.91	0.61		•	
4-1/8 F50G	1/8-27	7/16-20	9/16	0.172	1.00	0.64	•	•	
4-1/4 F50G	1/4-18	7/16-20	3/4	0.172	1.16	0.80	•	•	
5-1/4 F50G	1/4-18	1/2-20	3/4	0.234	1.19	0.83	•	•	
6-1/4 F50G	1/4-18	9/16-18	3/4	0.297	1.16	0.77	•	•	
6-3/8 F50G	3/8-18	9/16-18	7/8	0.297	1.28	0.89	•	•	
6-1/2 F50G	1/2-14	9/16-18	1 1/8	0.297	1.53	1.14		•	
8-1/8 F50G	1/8-27	3/4-16	7/8	0.391	0.80	0.36		•	
8-1/4 F50G	1/4-18	3/4-16	7/8	0.391	1.13	0.69	•	•	
8-3/8 F50G	3/8-18	3/4-16	7/8	0.391	1.28	0.84	•	•	
8-1/2 F50G	1/2-14	3/4-16	1 1/8	0.391	1.50	1.06	•	•	
10-1/4 F50G	1/4-18	7/8-14	1	0.500	0.81	0.31	•	•	
10-3/8 F50G	3/8-18	7/8-14	1	0.500	1.31	0.81	•	•	
10-1/2 F50G	1/2-14	7/8-14	1 1/8	0.500	1.53	1.03	•	•	
10-3/4 F50G	3/4-14	7/8-14	1 3/8	0.500	1.63	1.13	•		
12-1/4 F50G	1/4-18	1 1/16-12	1 1/4	0.656	1.00	0.41		•	
12-3/8 F50G	3/8-18	1 1/16-12	1 1/4	0.656	1.00	0.41		•	
12-1/2 F50G	1/2-14	1 1/16-12	1 1/4	0.656	1.41	0.82	•	•	
12-3/4 F50G	3/4-14	1 1/16-12	1 3/8	0.656	1.72	1.13	•	•	
14-1/2 F50G	1/2-14	1 3/16-12	1 3/8	0.719	1.06	0.47	•		
14-3/4 F50G	3/4-14	1 3/16-12	1 3/8	0.719	1.69	1.10	•		
16-1/2 F50G	1/2-14	1 5/16-12	1 1/2	0.844	1.00	0.41	•	•	
16-3/4 F50G	3/4-14	1 5/16-12	1 1/2	0.844	1.50	0.91	•	•	
16-1 F50G	1-11 1/2	1 5/16-12	1 5/8	0.875	1.88	1.29	•	•	
20-1 F50G	1-11 1/2	1 5/8-12	1 7/8	1.078	1.00	0.41	•	•	
20-1 1/2 F50G	1 1/2-14	1 5/8-12	2 1/4	1.078	2.16	1.56	•	•	
20-1 1/4 F50G	1 1/4-11 1/2	1 5/8-12	2	1.078	1.97	1.38	•	•	
24-1 F50G	1-11 1/2	1 7/8-12	2 1/8	1.344	1.00	0.41	•	•	
24-1 1/4 F50G	1 1/4-11 1/2	1 7/8-12	2 1/8	1.312	1.94	1.35	•	•	
24-1 1/2 F50G	1 1/2-11 1/2	1 7/8-12	2 1/4	1.344	2.00	1.41	•	•	
32-2 F50G	2-11 1/2	2 1/2-12	2 7/8	1.781	2.06	1.47	•	•	

BSPF Female Elbow

A4OEG4M

Male BSPP short* / Female BSPP short*

Part Number Information
A4EG4M - Body only
A4OEG4M - Assembled with O-ring

All dimensions are in millimeters

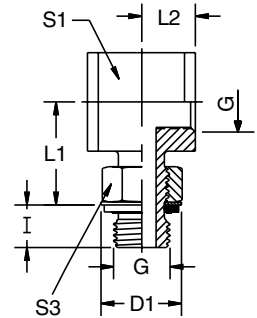

TUBE FITTING PART #	D1	G	I	L1	L2	S1	S3	STANDARD MATERIAL FROM STOCK		
								S	SS	B
2-2A4OEG4M	15	G 1/8 A	6.5	18.5	7	15	14	•		

*Male and female thread lengths have been shortened for compact design. The lengths do not conform to ISO 1179 / DIN 3852-2.

ISO 6149* Female Elbow

A87LPOEG87LPM

Male ISO 6149 short* / Female ISO 6149 short*

Part Number Information
A87LPEG87LPM - Body only
A87LPOEG87LPM - Assembled with O-ring

All dimensions are in millimeters

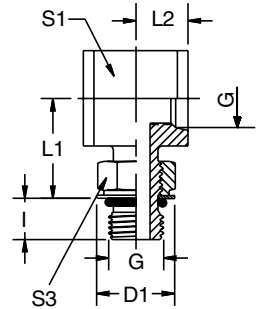

TUBE FITTING PART #	D1	G	I	L1	L2	S1	S3	STANDARD MATERIAL FROM STOCK		
								S	SS	B
M08A87LPOEG87LPM	12.5	M8X1	8.5	13.5	7.5	15	12	•		
M10A87LPOEG87LPM	14.5	M10X1	8.5	14.5	7.5	15	14	•		
M12A87LPOEG87LPM	17.5	M12X1.5	11	17	10	20	17	•		
M14A87LPOEG87LPM	19.5	M14X1.5	11	18	10	20	19	•		

*Male and female thread lengths have been shortened for compact design. The lengths do not conform to ISO 6149.

ISO 6149 Hex Head Plug P87OMN

Metric straight thread O-ring plug – ISO 6149-4*
For ISO 6149-1 port

SAE J2244-4* 62M0109A
Part Number Information
P87MN - Plug Only
P87OMN - Plug with O-ring

All dimensions in millimeters.

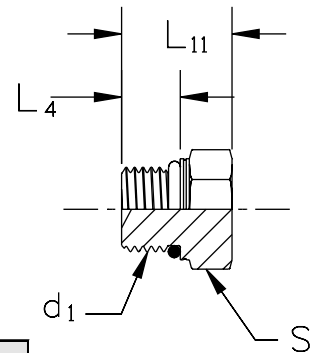

TUBE FITTING PART #	d1 THREAD	L4 (mm)	L11 (mm)	S HEX (mm)	STANDARD MATERIAL FROM STOCK		
					S	SS	B
M8P87OMN	M8X1	8.5	16.2	12	•		
M10P87OMN	M10X1	8.5	16.2	14	•		
M12P87OMN	M12X1.5	11.0	18.5	17	•		
M14P87OMN	M14X1.5	11.0	19.5	19	•		
M16P87OMN	M16X1.5	11.5	21.5	22	•		
M18P87OMN	M18X1.5	12.5	23.5	24	•		
M20P87OMN	M20X1.5	12.5	24.0	27	•		
M22P87OMN	M22X1.5	13.0	25.5	27	•		
M27P87OMN	M27X2	16.0	32.0	32	•		
M30P87OMN	M30X2	16.0	32.0	36	•		
M33P87OMN	M33X2	16.0	32.0	41	•		
M42P87OMN	M42X2	16.0	34.0	50	•		
M48P87OMN	M48X2	17.5	35.5	55	•		
M60P87OMN	M60X2	17.5	33.0	65	•		

*SAE J2244-4 and ISO 6149-4 are draft standards.
Note: For replacement O-rings, see page H124.

Metric Hollow Hex Plug VSTI M-ED

For ISO 9974-1 / DIN 3852-1 port
Metric Parallel Thread Plug with form E (Elastic) Seal

All dimensions in millimeters.

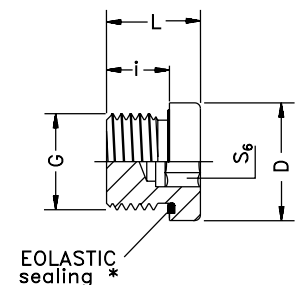

TUBE FITTING PART #	G METRIC THREAD	D	i (mm)	L (mm)	S6	STANDARD MATERIAL FROM STOCK		
						S	SS	B
VSTI10X1EDA3C	M10 x 1	14	8	12	5	•	•	
VSTI12X1.5EDA3C	M12 x 1.5	17	12	17	6	•	•	
VSTI14X1.5EDA3C	M14 x 1.5	19	12	17	6	•	•	
VSTI16X1.5EDA3C	M16 x 1.5	22	12	17	8	•	•	
VSTI18X1.5EDA3C	M18 x 1.5	24	12	17	8	•	•	
VSTI20X1.5EDA3C	M20 x 1.5	26	14	19	10	•	•	
VSTI22X1.5EDA3C	M22 x 1.5	27	14	19	10	•	•	
VSTI26X1.5EDA3C	M26 x 1.5	32	16	21	12	•	•	
VSTI27X2EDA3C	M27 x 2	32	16	21	12	•	•	
VSTI33X2EDA3C	M33 x 2	40	16	22.5	17	•	•	
VSTI42X2EDA3C	M42 x 2	50	16	22.5	22	•	•	
VSTI48X2EDA3C	M48 x 2	55	16	22.5	24	•	•	

*For replacement ED seals, see page H123.
Note: Available with fluorocarbon (e.g., Viton) seals as a standard for steel fittings.

BSPP Hollow Hex Plug VSTI R-ED

BSPP Thread Plug with form E (EOlastic) Seal
For ISO 1179-1 / DIN 3852-2 Port

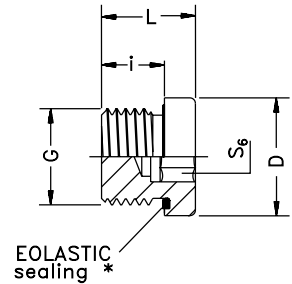

All dimensions in millimeters.

TUBE FITTING PART #	G THREAD BSP	D	i (mm)	L (mm)	S6	STANDARD MATERIAL FROM STOCK		
						S	SS	B
VSTI1/8EDA3C	G 1/8 A	14	8	12	5	•	•	
VSTI1/4EDA3C	G 1/4 A	19	12	17	6	•	•	
VSTI3/8EDA3C	G 3/8 A	22	12	17	8	•	•	
VSTI1/2EDA3C	G 1/2 A	27	14	19	10	•	•	
VSTI3/4EDA3C	G 3/4 A	32	16	21	12	•	•	
VSTI1EDA3C	G 1 A	40	16	22.5	17	•	•	
VSTI1 1/4EDA3C	G 1 1/4 A	50	16	22.5	22	•	•	
VSTI1 1/2EDA3C	G 1 1/2 A	55	16	22.5	24	•	•	

*For replacement ED seals, [see page H123](#).

Note: Available with fluorocarbon (e.g., Viton) seals as a standard for steel fittings.

ISO 6149 Hollow Hex Plug VSTI M-OR

Metric straight Thread O-Ring Plug – ISO 6149-4**
For ISO 6149-1 port

SAE J2244-4* 62M0109B

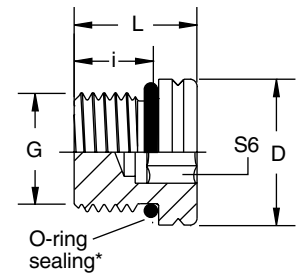

All dimensions in millimeters.

TUBE FITTING PART #	G METRIC THREAD	D	i (mm)	L (mm)	S6	STANDARD MATERIAL FROM STOCK		
						S	SS	B
VSTI10X1ORA3C	M10 x 1	13	9.5	13.5	5	•		
VSTI12X1.5ORA3C	M12 x 1.5	17	11.0	16.0	6	•		
VSTI14X1.5ORA3C	M14 x 1.5	19	11.0	16.0	6	•		
VSTI16X1.5ORA3C	M16 x 1.5	21	12.5	17.5	8	•		
VSTI18X1.5ORA3C	M18 x 1.5	23	14.0	17.0	8	•		
VSTI22X1.5ORA3C	M22 x 1.5	27	15.0	20.0	10	•		
VSTI27X2ORA3C	M27 x 2	32	18.5	23.5	12	•		
VSTI33X2ORA3C	M33 x 2	38	18.5	25.0	14	•		
VSTI42X2ORA3C	M42 x 2	48	19.0	25.5	22	•		

*For replacement O-rings, [see page H124](#).

**ISO 6149-4 and SAE J2244-4 are draft standards.

Note: Available with fluorocarbon (e.g., Viton) O-rings as a standard for steel fittings.

BSPT Pipe Nipple FF33M

Male BSPT / Male BSPT

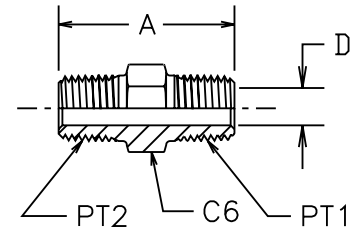

TUBE FITTING PART #	PT1 MALE BSPT	PT2 MALE BSPT	C6 HEX (mm)	D (mm)	L (mm)	STANDARD MATERIAL FROM STOCK		
						S	SS	B
1/8FF33M	1/8-28	1/8-28	10	4.8	21	•		
1/4x1/8FF33M	1/4-19	1/8-28	14	4.8	27	•		
1/4FF33M	1/4-19	1/4-19	14	7.0	29	•		
3/8x1/4FF33M	3/8-19	1/4-19	17	7.0	30	•		
3/8FF33M	3/8-19	3/8-19	17	10.3	30	•		
1/2FF33M	1/2-14	1/2-14	22	14.0	39	•		
1/2x3/8FF33M	1/2-14	3/8-19	22	10.3	43	•		
3/4FF33M	3/4-14	3/4-14	27	18.0	46	•		
3/4x1/2FF33M	3/4-14	1/2-14	27	13.5	50	•		
1FF33M	1-11	1-11	36	23.5	59	•		

BSPP Female Union GG44M

Female BSPP / Female BSPP

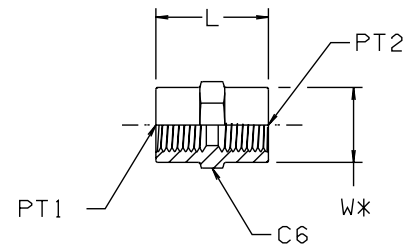

*W DIAMETER MAY BE PRESENT DUE TO MANUFACTURING OPTION

TUBE FITTING PART #	PT1 FEMALE BSPP	PT2 FEMALE BSPP	C6 HEX (mm)	L (mm)	STANDARD MATERIAL FROM STOCK		
					S	SS	B
1/8GG44M	1/8-28	1/8-28	14	19.0	•		
1/4GG44M	1/4-19	1/4-19	17	28.0	•		
3/8GG44M	3/8-19	3/8-19	22	28.0	•		
3/8x1/4GG44M	3/8-19	1/4-19	22	28.0	•		
1/2GG44M	1/2-14	1/2-14	27	32.5	•		
1/2x3/8GG44M	1/2-14	3/8-19	27	31.0	•		
1GG44M	1-11	1-11	46	42.0	•		

BSPB Reducing Adapter / Expander

RI-ED

For ISO 1179-1 / DIN 3852-2 Port
Male BSPB with EOLastic Seal / Female BSPB

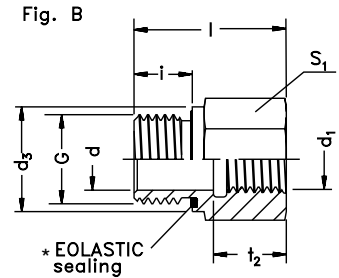
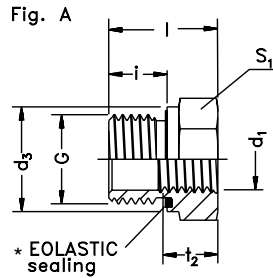

All dimensions in millimeters.

TUBE FITTING PART #	d1 FEMALE THREAD BSPB	G MALE THREAD BSPB	d (mm)	d3 (mm)	i (mm)	L (mm)	S1 (mm)	t2 (mm)	Fig.	STANDARD MATERIAL FROM STOCK		
										S	SS	B
RI1/8EDX1/4A3C	G1/4	G1/8A	4	14	8	31.0	19	17.0	B	•	•	
RI1/8EDX3/8A3C	G3/8	G1/8A	4	14	8	32.0	24	17.0	B	•	•	
RI1/4EDX1/8A3C	G1/8	G1/4A	5	19	12	29.0	19	12.0	B	•	•	
RI1/4EDX3/8A3C	G3/8	G1/4A	5	19	12	36.0	24	17.0	B	•	•	
RI1/4EDX1/2A3C	G1/2	G1/4A	5	19	12	40.0	30	20.0	B	•	•	
RI1/4EDX3/4A3C	G3/4	G1/4A	5	19	12	43.0	36	22.0	B	•	•	
RI3/8EDX1/8A3C	G1/8	G3/8A	—	22	12	22.5	22	8.0	A	•	•	
RI3/8EDX1/4A3C	G1/4	G3/8A	8	22	12	36.0	22	17.0	B	•	•	
RI3/8EDX1/2A3C	G1/2	G3/8A	8	22	12	41.0	30	20.0	B	•	•	
RI3/8EDX3/4A3C	G3/4	G3/8A	8	22	12	44.0	36	22.0	B	•	•	
RI1/2EDX1/8A3C	G1/8	G1/2A	—	27	14	24.0	27	8.0	A	•	•	
RI1/2EDX1/4A3C	G1/4	G1/2A	—	27	14	24.0	27	12.0	A	•	•	
RI1/2EDX3/8A3C	G3/8	G1/2A	12	27	14	37.0	27	17.0	B	•	•	
RI1/2EDX3/4A3C	G3/4	G1/2A	12	27	14	46.0	36	22.0	B	•	•	
RI1/2EDX1A3C	G1	G1/2A	12	27	14	49.0	41	24.5	B	•	•	
RI1/2EDX11/4A3C	G1 1/4	G1/2A	10	27	14	53.0	55	26.5	B	•	•	
RI3/4EDX1/4A3C	G1/4	G3/4A	—	32	16	26.0	32	12.0	A	•	•	
RI3/4EDX3/8A3C	G3/8	G3/4A	—	32	16	26.0	32	12.0	A	•	•	
RI3/4EDX1/2A3C	G1/2	G3/4A	16	32	16	43.0	32	20.0	B	•	•	
RI3/4EDX1A3C	G1	G3/4A	16	32	16	51.0	41	24.5	B	•	•	
RI3/4EDX11/4A3C	G1 1/4	G3/4A	16	32	16	55.0	55	26.5	B	•	•	
RI3/4EDX11/2A3C	G1 1/2	G3/4A	16	32	16	57.0	60	28.5	B	•	•	
RI1EDX1/4A3C	G1/4	G1A	—	40	18	29.0	41	12.0	A	•	•	
RI1EDX3/8A3C	G3/8	G1A	—	40	18	29.0	41	12.0	A	•	•	
RI1EDX1/2A3C	G1/2	G1A	—	40	18	29.0	41	14.0	A	•	•	
RI1EDX3/4A3C	G3/4	G1A	20	40	18	49.0	41	22.0	A	•	•	
RI1EDX11/4A3C	G1 1/4	G1A	20	40	18	57.0	55	26.5	B	•	•	
RI1EDX11/2A3C	G1 1/2	G1A	20	40	18	59.0	60	28.5	B	•	•	
RI11/4EDX1/2A3C	G1/2	G1 1/4A	—	50	20	32.0	50	14.0	A	•	•	
RI11/4EDX3/4A3C	G3/4	G1 1/4A	—	50	20	32.0	50	16.0	A	•	•	
RI11/4EDX1A3C	G1	G1 1/4A	25	50	20	53.0	50	24.5	B	•	•	
RI11/4EDX11/2A3C	G1 1/2	G1 1/4A	25	50	20	60.0	60	28.5	B	•	•	
RI11/2EDX1/2A3C	G1/2	G1 1/2A	—	55	22	36.0	55	14.0	A	•	•	
RI11/2EDX3/4A3C	G3/4	G1 1/2A	—	55	22	36.0	55	16.0	A	•	•	
RI11/2EDX1A3C	G1	G1 1/2A	—	55	22	36.0	55	18.0	A	•	•	
RI11/2EDX11/4A3C	G1 1/4	G1 1/2A	32	55	22	58.0	55	26.5	B	•	•	
RI2EDX11/2A3C	G1 1/2	G2 A	40	72	24	65.0	70	28.5	B	•		

*For replacement ED seals, see page H123.

BSPB Reducing Adapter / Expander

RI

For ISO 1179-1 / DIN 3852-2 Port
Male BSPB with Cutting Face / Female BSPB

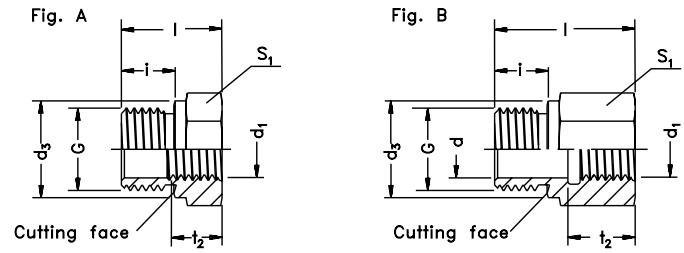

All dimensions in millimeters.

TUBE FITTING PART #	PT2 FEMALE THREAD BSPB	G MALE THREAD BSPB	d (mm)	d3 (mm)	i (mm)	L (mm)	S1 (mm)	t2 (mm)	Fig.	STANDARD MATERIAL FROM STOCK		
										S	SS	B
RI1/8X1/4A3CX	G 1/4	G 1/8A	4	14	8	31	19	17.0	B	•	•	•
RI1/8X3/8A3CX	G 3/8	G 1/8A	4	14	8	32	24	17.0	B	•	•	•
RI1/4X1/8A3CX	G 1/8	G 1/4A	5	18	12	28	19	12.0	B	•	•	•
RI1/4X3/8A3CX	G 3/8	G 1/4A	5	18	12	36	24	17.0	B	•	•	•
RI1/4X1/2A3CX	G 1/2	G 1/4A	5	18	12	40	30	20.0	B	•	•	•
RI1/4X3/4A3CX	G 3/4	G 1/4A	5	18	12	43	36	22.0	B	•	•	•
RI3/8X1/8A3CX	G 1/8	G 3/8A	—	22	12	22.5	22	8.0	A	•	•	•
RI3/8X1/4A3CX	G 1/4	G 3/8A	8	22	12	36	22	17.0	B	•	•	•
RI3/8X1/2A3CX	G 1/2	G 3/8A	8	22	12	41	30	20.0	B	•	•	•
RI3/8X3/4A3CX	G 3/4	G 3/8A	8	22	12	44	36	22.0	B	•	•	•
RI1/2X1/8A3CX	G 1/8	G 1/2A	—	26	14	24	27	8.0	A	•	•	•
RI1/2X1/4A3CX	G 1/4	G 1/2A	—	26	14	24	27	12.0	A	•	•	•
RI1/2X3/8A3CX	G 3/8	G 1/2A	12	26	14	36	27	17.0	B	•	•	•
RI1/2X3/4A3CX	G 3/4	G 1/2A	12	26	14	46	36	22.0	B	•	•	•
RI1/2X1A3CX	G 1	G 1/2A	12	26	14	49	41	24.5	B	•	•	•
RI1/2X11/4A3CX	G 1 1/4	G 1/2A	10	26	14	53	55	26.5	B	•	•	•
RI3/4X1/4A3CX	G 1/4	G 3/4A	—	32	16	26	32	12.0	A	•	•	•
RI3/4X3/8A3CX	G 3/8	G 3/4A	—	32	16	26	32	12.0	A	•	•	•
RI3/4X1/2A3CX	G 1/2	G 3/4A	16	32	16	41	32	20.0	B	•	•	•
RI3/4X1A3CX	G 1	G 3/4A	16	32	16	51	41	24.5	B	•	•	•
RI3/4X11/4A3CX	G 1 1/4	G 3/4A	16	32	16	55	55	26.5	B	•	•	•
RI3/4X11/2A3CX	G 1 1/2	G 3/4A	16	32	16	57	60	28.5	B	•	•	•
RI1X1/4A3CX	G 1/4	G 1A	—	39	18	29	41	12.0	A	•	•	•
RI1X3/8A3CX	G 3/8	G 1A	—	39	18	29	41	12.0	A	•	•	•
RI1X1/2A3CX	G 1/2	G 1A	—	39	18	29	41	14.0	A	•	•	•
RI1X3/4A3CX	G 3/4	G 1A	20	39	18	47	41	22.0	B	•	•	•
RI1X11/4A3CX	G 1 1/4	G 1A	20	39	18	57	55	26.5	B	•	•	•
RI1X11/2A3CX	G 1 1/2	G 1A	20	39	18	59	60	28.5	B	•	•	•
RI11/4X1/2A3CX	G 1/2	G 1 1/4A	—	49	20	32	50	14.0	A	•	•	•
RI11/4X3/4A3CX	G 3/4	G 1 1/4A	—	49	20	32	50	16.0	A	•	•	•
RI11/4X1A3CX	G 1	G 1 1/4A	25	49	20	52	50	24.5	B	•	•	•
RI11/4X11/2A3CX	G 1 1/2	G 1 1/4A	25	49	20	60	60	28.5	B	•	•	•
RI11/2X1/2A3CX	G 1/2	G 1 1/2A	—	55	22	36	55	14.0	A	•	•	•
RI11/2X3/4A3CX	G 3/4	G 1 1/2A	—	55	22	36	55	16.0	A	•	•	•
RI11/2X1A3CX	G 1	G 1 1/2A	—	55	22	36	55	18.0	A	•	•	•
RI11/2X11/4A3CX	G 1 1/4	G 1 1/2A	32	55	22	58	55	26.5	B	•	•	•
RI2X11/2A3CX	G 1 1/2	G 2A	40	68	24	62	70	28.5	B	•	•	•

Hex Head (BSPT) Pipe Plug

HP3M

Male (BSPT) pipe thread

All dimensions in millimeters.

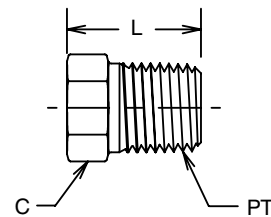

TUBE FITTING PART #	PT PORT THREAD NPTF	C HEX (mm)	L (mm)	STANDARD MATERIAL FROM STOCK		
				S	SS	B
1/8 HP3M	1/8-27	10	15.0	•		
1/4 HP3M	1/4-18	14	20.6	•		
3/8 HP3M	3/8-18	17	20.6	•		
1/2 HP3M	1/2-14	22	26.4	•		
3/4 HP3M	3/4-14	27	27.4			
1 HP3M	1-11 1/2	36	33.3			

[Click Here](#)
to Go to the First Page
of the Next Section

