

COSSA SPORT BYLAWS

AMENDED TO SEPTEMBER 2012

Contents

COSSA ALPINE SKIING	2
COSSA BADMINTON	5
COSSA BASKETBALL	8
COSSA CROSS COUNTRY RUNNING	9
COSSA CURLING	11
COSSA FIELD HOCKEY	12
COSSA FOOTBALL	13
COSSA GOLF	14
COSSA GIRL'S GYMNASTICS	16
COSSA BOYS' HOCKEY	17
COSSA GIRLS HOCKEY	19
COSSA BOYS LACROSSE	20
NORDIC SKIING	22
COSSA BOYS' RUGBY 15's	26
COSSA GIRLS' RUGBY	27
COSSA SNOWBOARDING	28
COSSA SOCCER	30
COSSA SWIMMING	31
COSSA TENNIS	33
COSSA TRACK AND FIELD	34
COSSA VOLLEYBALL	39
COSSA WRESTLING	41

COSSA ALPINE SKIING

Date: Event to be held no later than one (1) week prior to the OFSAA Championship race unless extraordinary circumstances dictate a change, and such a change is approved by the OFSAA convenor and COSSA Executive.

Convenor: Responsible for booking the site and organizing the event.

Location: To be decided no later than December 15th of the current school year.

Meet Structure: The event will be a one-day event with at least one run of Slalom and at least one run of Giant Slalom. Additional runs may be added at any time at the discretion of the COSSA convenor. If more than one run is taken by a racer his/her total time shall be used for scoring. DNF or DQ violations that are committed during a race shall apply to the run during which the violation occurred only. Violations committed prior to each race or during course inspection shall apply to the first run only. Violations committed off-course shall apply to the most recently completed run only.

Eligibility: Competitors must be eligible under the COSSA constitution, Article 12: Classification of Competitors and their District's Eligibility Rules.

Entries: Entries must be received by the host school no later than one (1) week prior to the date of the meet COSSA Championship meet. The following, from each district qualifier, are eligible to compete at the COSSA Championship meet:

- i) the top three teams, of up to five (5) racers, in each of Level I and II Boys' and Girls';
- ii) the top six individuals in each of Level I and II Boys' and Girls', if not already a member of qualifying team;
- iii) additional, fourth or lower placing teams, at the discretion of the district convener, up to a maximum of 60 racers in total;
- iv) one team in each of Level I and II Boys' and Girls' from the COSSA host school, if not already a qualifying team, at the discretion of the COSSA convenor.

All racers must be declared on the entry form. Any substitutions must be declared at the coaches' meeting, the morning of the event, and must race in the order of the skier they are replacing. All athletes must have competed at their district qualifier.

The entry fee will cover the operating costs of hosting the meet and may or may not cover the cost of lift tickets.

All other costs are the responsibility of the skier and/or their school.

Events:

The events to be conducted are: Level 1 Girls' Slalom, Level 1 Girls' Giant Slalom, Level 1 Boys' Slalom, Level 1 Boys' Giant Slalom, Level 2 Girls' Slalom, Level 2 Girls' Giant Slalom, Level 2 Boys' Slalom, Level 2 Boys' Giant Slalom,

Definition of Teams and Team Members:

Level I Team Racers: Participants are school-trained athletes only. They have no ski league affiliation, past or present, beyond the Nancy Green League or equivalent.

Level II Team Racers: Participants are those skiers who are club-trained beyond the Nancy Green level.

A member of the current year's provincial team, any division team or equivalent, ski academy team and/or enhanced racing club program is ineligible for COSSA competition. An enhanced program racer is an individual who trains and/or races four (4) or more days per week with a club.

A completed Racer Profile form will be a condition of entry into the COSSA Championship meet for all athletes. The COSSA convenor may check the status of any racer. Any racer with a missing, incomplete, or inaccurate Racer Profile form will be disqualified. It is the responsibility of each coach to ensure the validity of his/her teams' forms.

Teams: A school team skier is defined as an individual who practices under the direction of the designated school coach at least two times per week (dry land or on-hill), beginning no later than the week following the school Christmas break.

Scoring: Scoring shall be the same for each of Level I and II Boys' and Girls' as follows:

- a) The racer with the fastest time in each event shall receive one (1) point; the second fastest time, two (2) points; third, three (3) points, and so on. In the event of a tie, tied racers will be given an equal number of points, and an appropriate number of subsequent places will be excluded.
- b) Team scores shall be calculated by adding the points of the three fastest racers in Slalom to the points of the three fastest racers in Giant Slalom. In the event of a tie, the total time for each team shall be calculated by adding the times of the three fastest racers in Slalom to the times of the three fastest racers in Giant Slalom. The team with the lowest total time shall be declared the winner. If a tie still exists, the tie will be broken at the discretion of the convenor and the jury.
- c) Individual scores shall be calculated by adding the Slalom points to the Giant Slalom points for each racer. In the event of a tie, the total time for each racer shall be calculated adding his/her Slalom time to his/her Giant Slalom time. The racer with the lowest total time shall be declared the winner. If a tie still exists, the tie will be broken at the discretion of the convenor and the jury.

If a racer does not finish the course because he/she missed gate(s); skied off the course; missed the finish line; was overtaken by another skier while on course; or fell and failed to resume racing within 30 seconds he/she shall be scored as a "Did Not Finish" (DNF) and shall be assigned one more point than the slowest finishing racer in the event. This racer's points may be used in the calculation of team and individual scores.

A racer shall be scored as "Disqualified" (DQ) for committing any the following violations: did not start; failed to wear a helmet; used profanity on course; deliberately interfered with another racer on course; failed to lower safety bar on chair lift; passed gates, shadowed course, or did not display bib during course inspection; showed disrespect for officials, coaches, resort employees or fellow racers; or any other reason deemed appropriate by the convenor and jury.

If a racer is disqualified from Slalom or Giant Slalom, he/she will not be assigned points for that event. This racer may not contribute to his/her team's score for the event from which he/she is disqualified. Points assigned from the other event may still be used in the calculation of the team score. Since points from both events are required for calculation of individual scores, disqualified racers are not eligible for an individual award.

The convenor shall post a list of racers scored as DNF or DQ for Slalom immediately following completion the Slalom runs. The convenor shall post a list of racers scored as DNF or DQ for Giant Slalom immediately following completion the Giant Slalom runs. DNF and DQ decisions may be appealed within 10 minutes of posting the list. A jury of three coaches from schools not involved with the appeal will make the final decision on the appeal.

Rule Book: The current F.I.S. International Ski Competition Rules (ICR) will be used with the exceptions included in these by-laws.

Uniform and Equipment: All skiers must have ski brakes. A protective helmet designed for snow sports must be worn by all racers during both Slalom and Giant Slalom events.

All racers are permitted to wear downhill suits.

Awards: Team championships shall be declared for each of Level I and II Boys' and Girls'. Medals shall be presented to the first two teams in each category (five medals for each team) and ribbons shall be presented to the third, fourth, fifth, and sixth place teams in each category (five ribbons for each team).

Individual championships shall be declared for each of Level I and II Boys' and Girls'. Medals shall be presented to the first two individuals in each category and ribbons shall be presented to the third, fourth, fifth, and sixth place individuals in each category.

COSSA BADMINTON

1. Date:

The COSSA Championship shall be held one week prior to the OFSAA set date, unless extraordinary circumstances dictate a change.

2. Events:

There will be a Junior and Senior COSSA competition.

The events to be conducted are:

LADIES SINGLES MEN'S SINGLES MIXED DOUBLES

LADIES DOUBLES MEN'S DOUBLES

3. Tournament Structure and Procedure:

(A) There will be a Junior and Senior COSSA tournament.

(i) Juniors - Individual's birth certificate indicates that he/she has not yet reached his/her 15th birthday by January 1st prior to the start of the school year in which the competition is held.

(ii) Seniors - Individual's birth certificate indicates that he/she has not yet reached his/her 19th birthday by January 1st prior to the start of the school year in which the competition is held.

(iii) Both Juniors and Seniors must meet regular COSSA qualifications for competition.

(B) The draw format is a modified double elimination where the draw sheets for the five events will be played between the districts in accordance with the following matching:

Q1 vs K4 K1 vs Q4

K2 vs Q3 Q2 vs K3

(C) Players are to supply their own racquets and practice birds.

(D) Refer to OFSAA scoring system section 7 (7.1-7.6)

(E) Each match is the best two out of three games to 21 points. Each game must be won by two points with a ceiling of 30 points.

(F) Players may be coached between games one - two and two - three during the two minute break. Two coaches are allowed on the court.

(G) 60 second optional break at 11 points to get water and/or clean glasses. [No coaching permitted]

(H) Players are expected to introduce themselves to their opponent prior to the match and shake hands upon completion of the match.

(I) The convener shall provide score keepers for each match (teachers and/or students), and linesman for the medal games.

(J) The convener shall include in the pre-tournament information the fact that students who appear at the tournament without a proper supervising staff member shall not be eligible to compete.

(K) The top four (2) finishers from each division at the senior COSSA shall be eligible for OFSAA.

5. Entry

- (A) Kawartha and Bay of Quinte Districts must forward their competition results to the COSSA convener and include both names of their competitors and their schools.
- (B) AELS eligibility forms, properly signed, must be received by the COSSA convener prior to the start of the tournament.
- (C) Should any school fail to fulfill its prior commitment to attend the COSSA championship tournament that school shall pay the entry fee for the absent competitor.

6. Expenses:

- (i) An Entry Fee shall be charged which shall be sufficient to cover the operating costs of the tournament. The fees will be provided in the pre-tournament information provided by the COSSA convener.
- (ii) All OFSAA entries must be made and paid to the Senior COSSA convener at the COSSA tournament.
- (iii) the senior convener will be responsible for providing a COSSA Badminton T-shirt to the top 2 teams/players advancing to the OFSAA tournament.

7. Eligibility:

Shall meet the requirements of the OFSAA Eligibility By-laws 5, section 8(a-h).

8 Rules:

- (A) each match is the best 2 out of 3 games
- (B) all games go to 21 points, must win by two points with a ceiling of 30 points
- (C) warm ups are limited to three (3) minutes
- (D) at 11 points a one minute break is optional and players may NOT leave the court or be spoken too
- (E) two coaches may advise only between games #1 and #2 and #2 and #3
(2 minute limit)

9. Uniforms:

Competitors must wear proper clothing : a t-shirt that is 90% white in colour or a school coloured uniform top; white or black, or school coloured shorts. Shorts may not be below the knee in length. Doubles uniforms must be matching top and bottom uniforms. Competitors in violation of the dress code must be notified by the convener prior to the start of their match of the violation. Competitors must be wearing proper attire by the beginning of their match or forfeit the match. (Once a match has started, it can not be interrupted for a dress code violation.) Shorts can not be below the knee (OFSAA Playing Regulations 16).

10 Equipment:

The bird to be used shall be the same as the one at OFSAA. The COSSA convener is to state in advance the type of bird being used.

All competitors participating at COSSA championships must wear protective eyewear whenever they are on the court. Protective eyewear must meet ASTM FEO3 approval.

11. Awards:

Medals will be presented to first and second place finishers for each event.

Team points are awarded to be awarded as follows: 1st - 15 points; 2nd - 12 points; 3rd - 9 points; 4th - 6 points; 5th - 3 points; 6th - 3 points.

12. Supervision:

Refer to OFSAA By-Law 6 section 1)

13. Jury of Appeal:

The Jury of Appeal shall consist of three (3) individuals: the convener and two volunteers from two different districts the Bay of Quinte and the Kawartha Athletic Associations. Should an appeal be made of an athlete from a school of one or more of the three (3) jury members, alternate members will be appointed. The jury of Appeal shall handle disputes which fall in the realm of:

- (A) Tournament Structure and Procedure
- (B) Rules and Regulations
- (C) Uniforms and Equipment
- (D) Scoring

COSSA BASKETBALL

1. Schools will be classified as 'A', 'AA', 'AAA', or 'AAAA' based on OFSAA classifications for Senior only. Any school, with district approval, may elect to compete up.
2. COSSA Basketball will follow the rules and regulations of the National Federation Rule Book.
3. COSSA Basketball will be a four team tournament with the top two teams representing each district. If a district does not have an entry at any one level, the other district's champion will represent COSSA at the appropriate OFSAA level. If both districts have only one entry at any level, then there will be NO COSSA semi-final and just the COSSA final game. If one district has only one entry and the other district has two, there will be a playoff between the 2nd seed and the single district with the entry.
4. All finals, in each classification, are to be played at the same school, but the order of the finals is at the discretion of the Host Convenor to accommodate costs and travel.
5. Schools are to bring two sets of uniforms or tops. All members of the participating teams must be attired in similar colour and styled uniforms.
6. **AWARDS:** COSSA Champions will receive COSSA Gold medals while the runners-up shall receive COSSA Silver medals.
7. **FINANCES:** The cost of referees and medals will be recovered in the form of an entry fee, payable on the day of the championship.
8. If a single site is used, game times will be as follows:
Junior Semi-Finals: 10:00 AM and 11:30 AM Senior Semi-Finals: 1:00 PM and 2:30 PM
Junior Final: 4:00 PM Senior Final: 6:00 PM
If a double site is used, games times will be as follows:
Junior Semi-Finals: 12:00 PM Senior Semi-Finals: 1:30 PM or 20 minutes after
completion of the junior game
Junior Final: 4:00 PM Senior Final: 6:00 PM
Any changes must be made through the COSSA Executive.

COSSA CROSS COUNTRY RUNNING

PREAMBLE

1. The boys' and girls meets are to be held the same day, using the same location. The start time shall not be before 11:30 AM.
2. Maps are to be provided for each school on race day. These maps should clearly show the courses to be used.
3. **RACE ORDER:** To be decided by the District Convening, keeping in mind the race distances, marshalling locations, etc.
4. The Host District may hold the COSSA meet on the same course as the District Meet.

COURSES

1. Race Distances shall conform to the same ones required by OFSAA.

Midget Girls' - 3000m	Midget Boys' - 5000m
Junior Girls' - 4000m	Junior Boys' - 6000m
Senior Girls' - 5000m	Senior Boys' - 7000m

A 400m tolerance is permitted in each race .

2. Adequate marshals should be stationed around the course. Communication devices, if available, should be used.
3. The courses should be properly marked off with stakes.

ENTRIES

1. Only those runners whose names appear in the AELS System, on the COSSA eligibility sheets, shall be eligible to compete at COSSA. These eligibility sheets **MUST** be handed in at district meet and brought to the COSSA Championship by district convenors or their representative. Schools are to provide a hard copy, with appropriate signatures at their District Championships. The District Convenor is to hand in **ALL** of their District's AELS sheets to the COSSA Convenor. In addition, all competitors must be eligible in accordance with the OFSAA Practice rule by the COSSA meet.
2. In order to qualify a team in a specific age category (minimum of 4 runners, no maximum), the school must have qualified a team at their district meet. Schools may only enter one team in any age category. Schools may move runners up to a higher age class at COSSA. Runners may not move down in a category, even though they are eligible to compete in that age class.
3. All runners must have competed at their District meet. In the event that a runner, on a team, is unable to compete at their District meet due to injury (a doctor's note may be required or compassionate reasons (death in the family) etc, the COACH **MUST** appeal, in writing, to the COSSA Cross Country convenor by Monday prior to the meet. If the appeal is granted, the athlete is only eligible for team competition and not individual competition.
4. District Convenors **MUST** send complete individual and team results to the Association convenor, a minimum of 3 days prior to the COSSA Championship date. These are the District's entries.
5. Entry Fees must be paid at Registration for COSSA.
6. **AGES** - COSSA will conform to OFSAA age classifications for competition.

SCORING

1. The place finish of the first four runners on each team will be added together to determine the team scores. (**3+6+24+40= 73 for the team score**)
2. Ties in any division will be broken by the finish place of the fourth runner (last counting runner) of the teams involved. (**ie. Team A - 1,5,6,30= 42/ Team B -3,4, 15, 20 = 42 ; Team B wins**).

3. The Overall Championship trophy will be awarded to the school with the greatest number of points, based on team standings from each of the six age class races.
4. Points are to awarded on a **10-8-6-4-2-1** basis for the six place teams in each race. A school does NOT have to compete in all six age class races to be declared champion. If a tie occurs in the overall championship, it shall NOT be broken.
5. Schools winning a team/overall championship(s) MUST bring the trophy (ies) to the next years meet!

AWARDS

1. COSSA medals are to be awarded to 1st and 2nd place individuals. Ribbons are to be awarded to 3rd, 4th, 5th, and 6th place individuals. COSSA gold and silver medals are to be presented to the first and second place teams. (to a maximum of the first 7 finishers on the team). Ribbons are to be presented to the members of the third place teams.(to a maximum of the first 7 finishers on the team)
2. Awards are to be ordered through the COSSA Secretary - Treasurer.

COSTS

1. Costs are to be kept at an affordable level. The purpose of the meet is not to make money for the host, nor is it to lose money. All profits are to be split according to the COSSA Constitution.

OFSAA ENTRIES

1. The convenor shall enter two teams of six runners (5 competitors plus one alternate) in each age division for OFSAA, as well as the top 3 individual finishers who were not on one of the qualifying teams. The fourth individual finisher not on a qualifying team shall be declared the Association's alternate.
2. All school teams and individuals who qualify for OFSAA MUST pay for the entries before they leave the COSSA Meet.
3. Schools MUST hand in their completed OFSAA Eligibility form, OFSAA Supervision form, and OFSAA Practice form upon registering for the OFSAA Meet.
4. If any individual or team is unable to compete at OFSAA, the coach must notify the COSSA Convenor at the time of the COSSA Meet so substitutions can be made.

COSSA CURLING

1. Curling shall be an open competition.
2. The rules of play shall follow the CCA. The tournament shall be a four team round robin format. Each District shall be entitled to send two teams.
3. The 4 rock zone rule (Free Guard Zone Rule) will be used in COSSA curling.
4. All games shall be eight ends in length.
5. The Boys' and Girls' competitions shall be held on the same day, at the same place.
6. All teams shall be accompanied by a teacher.
7. In case of a tie for first place the COSSA winner would be determined as follows:
 - (a) Match between the tied teams (if 2 teams are tied)
 - (b) If 3 teams are tied, the winner shall be determined by a "shoot-out". The format is as follows:
Each team member will throw one rock toward the glass on the ice on which their last game was played. Sweeping is allowed. Rocks will be scored and removed after each shot.
Scoring: Full Button - 8 points
Touching Button - 7 points
Full 4-foot - 6 points
Touching 4-foot - 5 points
Full 8-foot - 4 points
Touching 8-foot - 3 points
Full 12-foot - 2 points
Touching 12-foot - 1 point
8. If two teams are tied at the end of regulation play, an extra end (continuous play) will be played until such a time as a winner is declared.
9. Game starting times be scheduled at 3 hour intervals.
10. Teams are allowed two (2), one-minute time outs per game, called at any time a team is in control of the house.
11. At the end of 4 ends a five(5) minute timeout for each team shall be taken. The ice may be swept at this time.

COSSA FIELD HOCKEY

1. Age as OFSAA eligibility. To be eligible to compete at the OFSAA championship a school field hockey team must participate in a minimum of six (6) regulation length games and-or two (2) separate tournaments during a minimum four week period under the supervision of a teacher/coach.
2. Each game shall be officiated by two officials. Officials must have minimum and current Prov. A. rating.
3. The tournament will be a four team tournament. There will be 3 Kawartha representatives and 1 Quinte representative. This is subject to change if and when Quinte's involvement in Field Hockey changes. COSSA will be hosted every 3rd year by Bay of Quinte until such time Quinte's situation changes.
4. A team may consist of unlimited numbers, but only 20 medals will be awarded. Medals are for 1st and 2nd place only.
5. Games shall consist of 30 minute halves, with a five minute half-time and a 15 minute break between games.
6. The tournament shall be a single knock out.

Game 1	KD 1	vs	KD 3
Game 2	KD 2	vs	QD
Game 3	Winner of Game 1 vs winner of game 2		
7. Games tied after regulation time will have a 5 minute rest and then proceed with 2 x 7-1/2 minute halves with a 5-minute intermission. If still tied, each team will select 5 players listed on the game sheet (unless suspended) to take 5 penalty strokes, alternating with the opposing team. The team scoring the most goals wins. If still tied, a sudden death penalty stroke system will be used until the tie is broken. Any 5 players may start the sudden death series but no player may repeat a stroke until 4 players from her team have stroked.
8. Rules of play shall follow the OFSAA Field Hockey sport By-Laws.
9. There shall be a minimum of 30 minutes rest between any back to back games throughout the day, unless both coaches and officials agree to a change.
Committee for decisions: the top of two rated officials at the tournament plus the convenor (or uninvolved coach, if desired by the convenor) shall form a jury of appeal.
Any concerns not addressed here should follow this procedure. COSSA Constitution, OFSAA Championship Constitution, the Rules of the International Field Hockey Federation.
10. The tournament shall not start before 10:00 AM.

COSSA FOOTBALL

1. Each district shall send one Junior and one Senior team to the A/AA and AAA/AAA Championships.
2. The current Canadian Amateur Football Association Rule Book is now in effect.
Footballs used shall be According to this book. (i.e. U.S. ball now O.K.).
3. All quarters shall be 12 minutes in length and official CIAU timing rules will be used..
4. For crowd control, there should be a restraining area at least five yards from the sideline.
5. Home teams shall have a three "legal" ball rotation available at all times in case of inclement weather.
6. COSSA finals must be played on the date decided at the COSSA Annual Meeting. Changes must be made through the COSSA Executive.
7. Officials shall come from the host District.
8. COSSA awards are to be paid for by the two finalists in each District.
9. Football ties at the end of regulation time are broken using the following format. Following a coin toss each team will be given an opportunity to score as follows: each team will scrimmage the ball at the 35 yard line and may advance by consecutive series of downs until it scores or loses the ball. The ball will be scrimmaged at the same end of the field for both teams. The ball is live until the whistle blows. This means a team can score on an interception. If the score is still tied, then the procedure is repeated until a winner is declared.
10. The Junior championships shall be played on Thursday in opposite Districts. The Senior championships shall be played on Friday in opposite Districts. All games shall start at 12:00 PM. If one set of games falls on November 11th, then that set of games shall be moved to Wednesday.

COSSA GOLF

PREAMBLE

The COSSA tournament will be comprised of the following teams: Kawartha 4 teams and Bay of Quinte 4 teams (Boys and Girls). The top four individual boy golfers and the top four female individual girl golfers representing Kawartha and Bay of Quinte not on the top 4 teams entered will also qualify for this event. If there are more than 4 top female golfers from each district, the convenors may verbally agree to allow all female golfers participate if they have qualified with a score not more than 110.

Groupings Order: The golf groupings will include 2 athletes from Kawartha and 2 athletes from Bay of Quinte in a foursome. When possible, no athlete from the same school will play with another athlete from their school. Each district will rank their golfers and each group will include similar rankings.

OFSSA ENTRIES

1. The top finishing females (handicap under 20) at COSSA qualify to Ofsaa tournament. Ofsaa sets a deadline of number of qualifiers each year. The remaining golfers are eligible to play in the non competitive tournament (handicap over 20) depending on the numbers Ofsaa allows.
2. If any individual or team is unable to compete at OFSAA, the coach must notify the COSSA Convenor at the time of the COSSA tournament so substitutions can be made.

PLAYING REGULATIONS

1. Facilities

Convenors should attempt to secure the following for the COSSA Championship.

- a) Boys: a course with a minimum slope rating of 110 or a minimum of 5750 yards.
- b) Girls: For the competitive division, a course with a minimum slope rating of 100 or a minimum of 4900 yards.

2. Tournament Structure and Procedure:

- a) The convenor will try wherever possible to see that competitors from the same school shall not be paired together in a foursome. The convenor must have players from each qualifying area in each grouping. The groupings outlined in the preamble may be altered to accommodate these requirements if necessary.
- b) Every foursome will be allocated a designated teacher supervisor, if available, to assist in keeping the foursome on schedule with respect to play. Every attempt will be made not to put teachers/coaches with foursomes which include their own athletes.
- c) Coaching will not be permitted on the course.
- d) Caddies will not be permitted for participants.
- e) Association convenors should provide rankings for the players.
- f) Convenor should provide and make available a pin position sheet for all participants.

3. Scoring:

- a) In the boys and girls team competition the top three (3) scores will be used to calculate the team score.
- b) Boys and Girls individual champions will be determined by the lowest 18 hole score of the day.

4. Expenses:

An Entry Fee shall be charged which shall be sufficient to cover the operating costs of the Championship. Those schools having entries are responsible for arranging and financing their own travel, meals, entry fees and accommodations (if necessary) for the event.

5. Eligibility:

To represent a school in any activity coordinated by the Federation a student **must:**

- (i) be eligible for competition under the Constitution, By-Laws and Standing Rules (Playing

Regulations) of this Association.

(ii) be certified as eligible by the Principal of the school and therefore be on the eligibility list presented to the convenor prior to the first competition of the season. A maximum of eight eligible players may appear on this list.

(iii) meet the following age requirement: the individual's birth certificate indicates that he/she has not reached his 19th birthday by January 1st prior to the start of the school year in which the competition is held.

6. Rules and Officials:

The laws of the current version of the RCGA Rules shall govern play at COSSA Golf. Local course rules will supersede RCGA rules. Any rule changes must be communicated to all participants and coaches, in writing, before the tournament begins.

The convenor(s) and or designate(s) (a Golf Professional from the participating golf club is strongly recommended) will function as head official(s) for the championships.

7. If there is a tie for first place for individual play, a sudden death playoff will take place. The starting hole will be determined based on golf course availability.

b) The team competition is determined by the best 3 scores out of 4 golfers. If there is a tie:the fourth score will be used, and if there is still a tie, a sudden death playoff will take place where 2 golfers from each team selected by the coach will play in a combined score sudden death playoff.

8. Uniforms and Equipment:

All competitors are expected to dress in proper golf attire that is neat, clean and which meets the dress code in effect at the course hosting the tournament. Student-athletes must remain fully clothed in the appropriate attire in the competition area, AND use the designated locker room or change area to change to and from competition attire.

9. Supervision: (Reference By-Law 6, Section 1)

COSSA supervision rules apply to all Golf championships.

10. Registration:

Registration materials will only be given to the teacher accompanying the team.

11. Jury of Appeal: The Kawartha and Bay of Quinte convenors as well as the Professional from the golf course will sit on the jury of appeal.

COSSA GIRL'S GYMNASTICS**1. PLAYING REGULATIONS**

COSSA accepts the OFSAA playing regulations as follows:

6. Eligibility
7. Events (including Sport Aerobics)
8. Rules of Competition
9. Competitive Divisions
10. Uniform (exception: gymnasts allowed to wear shorts)

COSSA accepts the OFSAA Appendix to the Playing Regulations (Equipment, Event Specifications, Event Regulations) with the exception that the higher score of the two vaults will be counted.

2. QUALIFYING FOR COSSA

- (a) Each District shall be allowed to send its top ten competitors in each event.
- (b) The top three All Round Competitors at the District Meets shall compete All Round at COSSA. (This may mean sending more than ten to COSSA).

3. AWARDS

- (a) COSSA medals shall be awarded to the first and second place finishers for each event and all around for levels 1 through 5. Level 6 will receive medals for all around only. (26 gold and 26 silver)
- (b) Silver Trays will be awarded to All Round Champions at each level. It is the responsibility of the school to engrave the tray and return it the following year.
- (c) Overall Team Championship trophies will be awarded using the following method:
Levels 1,2 and 3 Team Trophies - 2 scores per event, total of 8 scores
Elite Team Trophy - 2 scores per event from any Level 4, 5 or 6 gymnasts on the team.
Because the scores are out of a variety of start values, the scores must be adjusted and calculated to reflect a score out of 10.0 for Levels 4, 5, and 6 team scores.

4. GENERAL INFORMATION

- (a) COSSA entry fees are to be paid for following the District meet. No refunds for scratches.
- (b) There will be a formal march in, in competitive attire, for the COSSA awards presentation at the end of the meet.
- (c) Coaches' lunch is not an allowable expense at this meet.

COSSA BOYS' HOCKEY

Eligibility

- 1 a) Any team entered in the Kawartha and Quinte leagues is eligible for post season play.
- b) Each coach will submit an 'eligibility' list to the convenor appropriate prior to start of league play. Each association convenor will submit the eligibility list of the league champion to the COSSA convenor prior to beginning COSSA play-offs.
- c) Coaches must notify the convenor of any roster additions prior to such player's participation in a game. This may be done by telephone, followed by written confirmation. This may be done by email, followed by an updated OFSAA AELS Eligibility List.
- d) All players must have completed 4 league games prior to play-off competition to become eligible for play-offs. ** see exceptions listed below
- i) Students who have previously attended the same school and are re-registering in the 2nd semester and have not been at another school in the interim, are eligible for playoffs provided they played in all of the team's 2nd semester games.
- ii) Students who are legitimate team members and cannot meet the 6 game (or all 2nd semester game) requirements due to injury or illness for all of the teams league games are eligible for playoffs after competing in a minimum of 2 of the teams league games. The player in question must have been placed on the team eligibility list prior to the teams final 5 games of the regular season.
- e) A player must be a full time student.
- f) A player must not take part in any Junior level hockey game, A, B, C, D, E, etc in any way, by signing a game sheet, sitting on the bench, being dressed, having his name on the game sheet, as of December 1st.
- g) A player who has transferred high schools, must go through the proper transfer policy channels for their district.

Rules

- 2 a) All Hockey Canada rules will govern except that COSSA and OFSAA rules will take precedence where applicable.
- b) The red line is used for icing only. Since it not used for "off-side"; teams must have the required number of players on the ice for each face off so that no advantage is gained.
- c) The maximum number of players permitted to dress for a game is twenty (20), eighteen (18) plus two (2) goaltenders.
- d) Coincidental minor penalites will not result in both teams being short handed.
- e) Double minor penalties will be given instead of a major penalty if the referee deems the infraction to be accidental and no injury occurs.
- f) Suspensions will follow the Ontario Hockey Federation(OHF) guidelines for minimum suspension time lines.
- g) If any player has received 3 minor penalties in a game, he shall be suspended from play for the balance of that game and upon receipt of a fourth minor. (Or third stick penalty, Hockey Canada rule)
- h) The Convenor and coaches shall be responsible for the enforcement of suspensions.
- i) Any player receiving a match penalty will receive a 2 to 5 game suspension.
- j) Players must wear mouth guards, ear flaps and neck guards. Goaltenders must also wear the protective flap with their goaltender mask.

3. Playoff Format

- a) COSSA Championship will be one day tournament in advance of the OFSAA Boys' Hockey deadline.
- b) The COSSA Championship will consist of two entrants from Bay of Quinte and two entrants from Kawartha. The semi-finals shall be held simultaneously on twin pads where practicable:

Bay of Quinte 1 vs Kawartha 2

Kawartha 1 vs Bay of Quinte 2

The winners of the semi-final games shall meet in the final which is to be played no sooner than 2 hours after the conclusion of the semi-final games.

- c) Games shall be three 15 minute stop time periods.
- d) Teams will retreat to their dressing rooms between the 2nd and 3rd period, at which time the ice is resurfaced.
- e) There shall be a 10 minute warm up prior to the game.
- f) The home team is responsible for renting adequate ice time in order to allow the game to run as outlined by COSSA by-laws.
- g) One referee and two linesmen must be assigned for each game.
- h) One time out per team per game.
- i) Overtime
 - i) Overtime play will consist of a fifteen minute stop time period sudden-death (first team to score will win the game)
 - ii) If after one stop time overtime period the score is still tied. A shoot out will occur.
- j) Shootout
 - i) Three (3) players from each team will participate in a one on one shoot out. If the score is still tied after the first set of three players, another set of 3 players will be selected to participate in the next shoot out. This format shall continue until a winner is declared.

4. Mercy rule will remain. Straight time during the last five minutes if the goal spread is 5 goals or more. Once started, the mercy rule will remain in effect if the goal spread becomes less than five.

5. Role of the Convenor

- a) The convenor will endeavor to provide, as far as possible, the services of the Hockey Canada 'carded' referees through the aid of a referee-in-chief.
- b) Will oversee the finances of the playoffs and submit a statement to COSSA Secretary/Treasurer.

COSSA GIRLS HOCKEY

1. All rules that govern OFSAA Girl's Hockey and OWHA shall apply to the COSSA Championship.
2. The COSSA Championship will be a one day tournament in advance of the OFSAA Girl's Hockey deadline.
3. The COSSA championship will consist of two entrants from Bay of Quinte and two entrants from Kawartha.
4. The semi-finals shall be held simultaneously on twin pads where practicable:
Bay of Quinte 1 vs Kawartha 2
Kawartha 1 vs Bay of Quinte 2
5. All games, including the Championship game, shall consist of three (3) twelve-minute stoptime periods with a five (5) minute warm-up directly before the start of the game and a three (3) minute rest time between periods. The warm-up and rest time between periods will be put up on the game clock. If there is a spread of five (5) or more goals the final period shall be straight time. If the point spread returns to a three-goal spread, it returns to stop time.
6. The winners of the semi-final games shall meet in the final which is to be played no sooner than two hours after the conclusion of the semi-final games.
7. In the case of a tie in any game, the overtime shall be a ten minute 3 on 3 sudden victory period. (Three skaters and a goalie per team.) If the game is still tied, a 3 player simultaneous shootout will occur with penalized players not eligible.
8. Any penalties incurred in the overtime shall result in the team who is not penalized adding a player for the time of the penalty. The penalized player must sit in the penalty box but her team may have three skaters.
9. Any penalty resulting in a one or more game suspension incurred in the COSSA gold medal game must be reported to the OFSSA convenor and the girl is ineligible to represent COSSA until the suspension is served.
10. Awards: Gold and silver medals will be awarded to the finalists.

COSSA BOYS LACROSSE**ELIGIBILITY**

See Article 12 of the COSSA Constitution.

Any Junior Age player, whose name appears on a Junior A box lacrosse game sheet, will be declared ineligible for a Junior Boys Lacrosse team.

TOURNAMENT STRUCTURE

The COSSA Championship will be a one day tournament in advance of the OFSAA Boys Lacrosse deadline.

2. The tournament shall begin no earlier than 10:00 AM
3. The COSSA Championship will consist of two entrants from the Bay of Quinte and two entrants from Kawartha.
4. The semi-finals will be: Bay of Quinte 1 vs Kawartha 2
Kawartha 1 vs Bay of Quinte 2

The winners of the semi final games shall meet in the final which is to be played no sooner than 2 hours after the conclusion of the semi final games.

PLAYING REGULATIONS

No games will be played unless there are 2 carded officials.

Each game will consist of 4 – 12 minute quarters.

Teams will change ends at the end of each quarter.

The last 2 minutes of the 4th quarter will be stop time if the score is within 2 goals.

Time outs are 2 per half per team and are one minute in duration.

Overtime, if necessary, will immediately go to successive sudden death 4-minute periods with no rest interval until a winner is declared. Teams shall change ends at the end of each period. No time outs in overtime.

PLAYER EQUIPMENT AND UNIFORMS

1. All players must wear:

- CSA approved helmet and mask with chinstrap fastened on both sides
- Full fit interior mouth guard at all times when on the playing field
- Gloves with fingers fully encased
- Shoulder pads
- Elbow pads

2. Goalies must wear a throat guard and chest protector.

3. Any player found in violation of #1 and/or #2 will receive a one minute personal foul and removal from the game until he can comply. All offending equipment must be repaired, removed or added subject to the official's discretion.

4. All teams must wear matching shirt and shorts. No duplicate numbers will be permitted on the same team. In cases where teams have similar coloured jerseys, it is the requirement of the home team to wear contrasting jerseys.

RULES OF THE GAME

The International Lacrosse Federation rule book will be in effect except for the special COSSA

Rules noted below:

Teams are allowed to use a maximum of 4 long sticks on the field at one time.

All players must report to the sidelines for a time-out. The coach must not go on to the field for time-outs.

Four personal fouls by one player during the game is a foul out.

Any swearing on the field is an automatic one minute personal foul. Players who 'jaw' or glare at each other, face-to-face, after a whistle on a stoppage of play will each receive a 1 minute unsportsmanlike foul. A 3 minute 'trash talking' foul will be called against any player, coach, or team personnel who taunts any player, coach, fan or bench personnel with derogatory or racial slurs even if it is directed at his own team.

Most slashing fouls will be two minutes in duration. Slashing will be closely called. All swinging of the stick that is not stick on stick will be a slashing penalty. All players should be taught and encouraged to poke on the ball if there are two hands on the stick. If a player is carrying a ball in the stick with one hand he must hit the stick when checking or with body type checking only. However, a 3 minute slashing foul will be called for any slash or swing in the judgement of the official that is deemed to intimidate the opponent or a deliberate attempt to injure.

Most spearing fouls will 2 minutes in duration. However, a 3 minute spearing penalty will be given to any player who in an attempt to poke an opponent in the judgement of the official uses a spear in a deliberate attempt to injure.

All 3 minute fouls result in an automatic game expulsion.

A goaltender does not serve any foul which is less than 3 minutes in duration. These fouls will be served by the designated defender. Should the goaltender receive a 3 minute foul he will removed from the game. Goaltenders are also subject to rule #3 regarding four personal fouls which result in a foul out.

AWARDS

COSSA Champions will receive COSSA Gold medals while the runners up shall receive COSSA Silver medals.

FINANCES

The cost of referees and medals as well as operational costs will be recovered in the form of an entry fee, payable on the day of the championship.

NORDIC SKIING**(1) Official Rule Book:**

COSSA Cross-Country Ski Championships will follow OFSAA race guidelines. The OFSAA race guidelines are based on the following sources:

- (a) FIS guidelines
- (b) Cross-Country Canada (CSA) guidelines
- (c) Cross-Country Ski Racing in the Extreme Cold (pamphlet from SOD)
- (d) Standards for Cross-Country Ski Race Organization (pamphlet from SOD)

Race Format:

The races shall be freestyle and skating shall be allowed at all times, including the start/finish areas. Racers should start 1-2 at a time, with 30 sec to 1 minute intervals between starting groups. There is a move at the OFSAA level to have 1 skier start every 30 sec, reducing possible crowding situations while on course. The race convener must ensure that the start and finish areas are sufficiently wide enough to allow skating. The use of “no skating zones” is strongly discouraged at divisional and OFSAA races. If a racer is late for his/her start, the racer will be allowed onto the course at the starters discretion, and the original start time will stand.

(2) Scheduling:

The COSSA Cross-Country Ski Meet shall be held annually on:

- (a) a Tuesday or Wednesday in February prior to the OFSAA championships

Note: Due to the small number of skiers participating in the COSSA Nordic

Championships over the past 10 years, the COSSA Championship has been held in conjunction with the CISAA Championship, held in Haliburton on the 2nd or 3rd Tuesday or Wednesday in February.

Future conveners and race locations will be determined at the coaches meeting that precedes the annual COSSA Championship Race. This information will be communicated to the COSSA Annual Meeting in May.

Race location and date may vary due to poor snow conditions.

(discretion of the race convener).

(3) Officials:

The race convener is responsible for organizing and supplying race officials.

(4) Events: (Individual and Relay)

- (a) Novice Boys/Girls *see note below
- (b) Junior Boys/Girls
- (c) Senior Boys/Girls

Schools may enter individuals/teams in each event. A team will consist of a minimum of 4 skiers and a maximum of 5. There is no limit on the maximum number of individual skiers a school can enter in any category.

Skiers may race in only one age category. For example;

A Junior boy/girl may not race in the Junior and Senior Events.

A coach could decide to race a Junior boy/girl in the senior category

A senior racer can not enter the Junior category

Generally, at least 4 skiers must be entered in a category before that category will be officially recognized (conveners discretion).

Special Note:

To encourage first year skiers to participate in races, many conveners have created a Novice Boys/Girls Category. Novice indicates a first year racer, regardless of age. This format has been very successful and resulted in more skiers participating at races. The COSSA coaches strongly support the introduction of the Novice category and have included it in the COSSA Championship.

Note:

Novice skiers do not count toward the team championships and cannot compete at OFSAA.

- (5) Eligibility:** Age categories as per OFSAA race guidelines, other than Novice
- (a) Novice Boys/Girls First year racer regardless of age
 - (b) Junior Boys/Girls the individual can not turn 16 by December 31 of school year
 - (c) Senior Boys/Girls the individual can not turn 19 by December 31 of school year

(6) Scoring:

Scoring will follow OFSAA guidelines.

Individual Awards:

Individual awards will be determined based on the results from the morning races.

In the Nordic Individual event, the Individual placing shall be determined by time.

Individual awards (medals) will be presented in each category to the 1st and 2nd place skier. Ribbons will be awarded to the 3rd, 4th, 5th and 6th place skiers in each category.

Team placings shall be determined by adding up the placings of the four fastest Team members in the Individual morning event. The lowest total will determine the Team event winner who will receive one point. The second lowest total shall be second in the Team event and will receive two points, and so on. No Team with three or fewer members shall receive a place or points.

Team Awards:

Team awards will be determined by combining the Team totals from the morning Individual races with the Sprint Relay results from the afternoon races. A sprint relay team shall consist of 4 skiers.

Nordic Team Sprint Relay placing will be determined, and points awarded. The first place team will be awarded 1 point, the 2nd place team 2 points, and so on, by the order of finish in the Sprint Final

Team awards (medals and plaques) will be awarded to the winning team in each category up to a maximum of 5 skiers. As per OFSAA guidelines, in the event of a tie at the completion of the sprint relay race, the position of the 4th skier from the individual results will be used to break a tie.

For example: School A and School B are tied at the completion of the sprint relay.

The 4th skier to count for School A placed 12th

The 4th skier to count for School B placed 9th

School B would win the team category based on the position of their 4th skier.

(7) Race Distances:**(a) Individual Races:**

All race distances are based on OFSAA guidelines. Individual race distances will vary with snow conditions and race site. The course must be wide enough to permit skating.

- (a) Novice Boys/Girls 2km + or - .5km
- (b) Junior Girls 4km + or - 1km
- (c) Junior Boys 5km + or - 2km
- (d) Senior Girls 5km + or - 2km
- (e) Senior Boys 8km + or - 2km

(b) Sprint Relay Races:

Sprint relay courses will normally be as close to 800m as possible. Sprint relay race distances will vary with snow conditions and race site. The course must be wide enough to permit skating

- (1) Jr. Girls/Jr. Boys 4 x 800m
- (2) Sr. Girls/Sr. Boys 4 x 800m

(8) OFSAA Qualification:

(a) Teams: The winning team in each category will qualify to represent COSSA at the OFSAA Championship. A team consists of a maximum of 5 skiers.

(b) Individuals: The top 3 individuals, in the top ten, in each category, not on a winning team, will qualify to represent COSSA at the OFSAA Championship.

Additional Entries: The Convener, with input from the coaches, will then examine the remaining skiers in the top ten, in each category, to determine if they are competitive to compete at OFSAA. If a skier is selected to compete at OFSAA, the convener will contact the OFSAA convener and request that the skier be sent as an additional association entry.

(9) Uniforms:

As per OFSAA guidelines. No club, provincial, or national team racing suits will be permitted. Racing suits can not be taped or turned inside out in an attempt to meet race guidelines.

(10) Equipment:

As per OFSAA guidelines. Minimum ski length is 140 cm and there is no maximum ski width. Equipment may be exchanged only if broken during the race.

(11) Convener:

The convener shall send meet information, entry forms etc., to member schools at least three weeks prior to the competition. The convener should set an entry deadline that is 5-6 days prior to the race, and has the right to refuse late entries.

The convener must set an entry fee that will cover all expenses:

Site/grooming charges

Postage/phone etc.

Travel costs (gas, km)

Paper/photo copy costs

Awards

The convener will chair a coaches meeting on race day, prior to the start of the race, in order to:

- (a) clarify the race rules and regulations
- (b) choose a convener and site for the following year
- (c) discuss/review any changes to this constitution

The convener must organize a jury of appeal:

The jury of appeal shall consist of three individuals;

- the race convener

- two coaches

The jury of appeal will handle disputes which do not fall within the jurisdiction of the officials.

Protests must be submitted in writing to the convener by the coach, within 30minutes of the results for the race in question being posted. The decision of the Jury of Appeal is final.

(12) Sportsmanship and Conduct:

As per COSSA and OFSAA guidelines. Coaches must accept final responsibility for the actions of their skiers. Poor sportsmanship/conduct by an individual skier or team may result in that skier or team being disqualified from the competition.

COSSA BOYS' RUGBY 15's**GENERAL**

1. All games will be played in accordance with the Canadian Rugby Union Laws of the Game.
2. Modifications authorized by the Ontario Rugby Union for school aged players will be followed.
3. Each district is allowed two entries. If either district has no second place team, the third place team from the other district shall compete.
4. Players must wear a mouthguard at all times while playing.

TOURNAMENT STRUCTURE

1. Junior and Senior tournaments are to be held on the same day and in the same location. The tournament shall begin no earlier than 10:00 AM.
2. Each Championship shall be a single day tournament with semifinal and final games. The semi final games will consist of the first place team in each district playing the second place team in the other district. The winners will meet in the championship. All games will be 40 minutes in length (two 20 minute halves with a five minute rest period in between). If a player is ejected from a semifinal game he is not allowed to play in either the consolation final or the championship game.

TIE BREAKER

1. If a semi-final game is tied at the end of regulation time, it will go directly to penalty kicks. If the finals are tied at the end of regulation time there will be a five minute rest period and then two five minute overtime halves will be played.
2. Kicks: Each team will select up to three (3) players, from among the players on the field at the end of regulation period. These players shall be organized to kick from designated spots at the same goalposts with the wind at their backs. A best of three format shall be used.

The kicks shall be in the following sequence on the 22m line:

- a) midway between sidelines and 22m
- b) left 15m line and 22m
- c) right 15m line and 22m line

SUBSTITUTIONS

1. Free substitution will be allowed between the 22 meter lines and upon the referees discretion. Substitution for an player may be made at any time (upon referees approval) . However, the player may not return to the game unless he is a member of the tight five (prop, hook, lock).

COSSA GIRLS' RUGBY

1. COSSA will run a varsity 15 a side playoff tournament to be held in the fall season.
2. The laws of the Canadian Rugby Union will govern with the following exceptions:
 - a) Each team shall provide a competent touch judge for each game. The referee will clarify to touch judges what their responsibilities are before the game begins.
 - b) All teams must wear uniforms of the same colour and pattern.
 - c) All teams must wear mouthguards at all times.
 - d) Should a player be ejected from a game for flagrant abuse of the rules or abusive language, she is no longer eligible for competition that game and is suspended for the next game. No replacement will be allowed for the remainder of the game during which the offence occurred.
3. The top two teams from Kawartha and Quinte will proceed to the COSSA play-offs.
4. Seeding : K1 vs Q2
Q1 vs K2

K1---

Q2---

_____ COSSA Champion

K2—

Q1---

5. COSSA games shall consist of 2 twenty (20) minute halves with a five (5) minute rest period between halves.
6. Ties must be broken by the OFSAA kicking tie-breaking formula with the exception that after the first round of kicks, if a tie still remains, the kicks become "sudden-death".
7. In all girl's rugby games played within COSSA, up to and including the COSSA finals that players be allowed to wear clothing appropriate to the weather as follows: full length spandex compression tights, skating tights or sweatpants are permitted but must be worn under the rugby shorts. Leggings must be seamless and not have zippers, snaps or pockets. Players would still not be allowed to use any knee or ankle braces with metal or hard plastic. The referee will have the final say as to whether the leggings pose a safety risk to other players. Gloves or mitts are permitted as long as there are no hard surfaces, snaps or buckles. Hats would be limited to regulation scrum caps. Long ties on hats are not permitted. Long sleeve t-shirts are allowed under the uniform.
8. Free substitution will be allowed between the 22 meter lines and upon the referees discretion
9. The tournament shall begin no earlier than 10:00 AM.

COSSA SNOWBOARDING

Date: Event to be held no later than one (1) week prior to the OFSAA Championship race unless extraordinary circumstances dictate a change, and such a change is approved by the OFSAA convenor and COSSA Executive.

Convenor: Responsible for booking the site and organizing the event.

Location: To be decided no later than December 15th of the current school year.

Meet Structure: The event will be a one-day event with two runs of Giant Slalom.

Eligibility: Competitors must be eligible under the COSSA constitution, Article 12: Classification of Competitors and their District's Eligibility Rules.

Entries: Entries must be received by the host school no later than one (1) week prior to the date of the meet COSSA Championship meet. The following, from each district qualifier, are eligible to compete at the COSSA Championship meet:

- i) the top three teams, of up to five (5) racers, in each of Level I and II Boys' and Girls';
- ii) the top six individuals in each of Level I and II Boys' and Girls', if not already a member of qualifying team;
- iii) additional, fourth or lower placing teams, at the discretion of the district convenor, up to a maximum of 60 racers in total;
- iv) one team in each of Level I and II Boys' and Girls' from the COSSA host school, if not already a qualifying team, at the discretion of the COSSA convenor.

All racers must be declared on the entry form. Any substitutions must be declared at the coaches' meeting, the morning of the event, and must race in the order of the skier they are replacing. All athletes must have competed at their district qualifier.

The entry fee will cover the operating costs of hosting the meet and may or may not cover the cost of lift tickets.

All other costs are the responsibility of the skier and/or their school.

Events:

The events to be conducted are: Level 1 Girls= Giant Slalom, Level 2 Girls= Giant Slalom, Level 1 Boys= Giant Slalom, Level 2 Boys= Giant Slalom

Definition of Teams and Team Members:

Level I Team Racers: Participants are school-trained athletes only.

Level II Team Racers: Participants are past or present members of the Canadian Snowboarding Federation and have competed at one or more CSF sanctioned events.

A completed Racer Profile form will be a condition of entry into the COSSA Championship meet for all athletes. The COSSA convenor may check the status of any racer. Any racer with a missing, incomplete, or inaccurate Racer Profile form will be disqualified. It is the responsibility of each coach to ensure the validity of his/her teams' forms.

Teams: A school team skier is defined as an individual who practices under the direction of the designated school coach at least two times per week (dry land or on-hill), beginning no later than the week following the school Christmas break.

Scoring: Scoring shall be the same for each of Level I and II Boys' and Girls' as follows:

- a) The racer with the fastest total time in both runs shall receive one (1) point; the second total fastest time, two (2) points; third, three (3) points, and so on. In the event of a tie, tied racers will be given an equal number of points, and an appropriate number of subsequent places will be excluded.
- b) Team scores shall be calculated by adding the points of the three fastest racers in the Giant Slalom. In the event of a tie, the total time for each team shall be calculated by adding the total times of the three fastest racers. The team with the lowest total time shall be declared the winner. If a tie still exists, the tie will be broken at the discretion of the convener and the jury.
- c) Individual scoring shall be calculated by total time. If a racer does not finish the course because he/she missed gate(s); rode off the course; missed the finish line; was overtaken by another rider while on course; or fell and failed to resume racing within 30 seconds he/she shall be scored as a ADid Not Finish@ (DNF) and shall be assigned one more point than the slowest finishing racer in the event. This racer's points may be used in the calculation of team and individual scores.

A racer shall be scored as "Disqualified" (DQ) for committing any the following violations: did not start; failed to wear a helmet; used profanity on course; deliberately interfered with another racer on course; failed to lower safety bar on chair lift; passed gates, shadowed course, or did not display bib during course inspection; showed disrespect for officials, coaches, resort employees or fellow racers; or any other reason deemed appropriate by the convenor and jury.

If a racer is disqualified, he/she will not be assigned points for that event. This racer may not contribute to his/her team's score. Disqualified racers are not eligible for an individual award.

The convenor shall post a list of racers scored as DNF or DQ for each Giant Slalom run immediately following completion the run. DNF and DQ decisions may be appealed within 10 minutes of posting the list. A jury of three coaches from schools not involved with the appeal will make the final decision on the appeal.

Uniform and Equipment: A protective helmet designed for snow sports must be worn by all racers. All racers are permitted to wear downhill suits and to use racing boards.

Awards: Team championships shall be declared for each of Level I and II Boys' and Girls'. Medals shall be presented to the first two teams in each category (five medals for each team) and ribbons shall be presented to the third, fourth, fifth, and sixth place teams in each category (five ribbons for each team).

Individual championships shall be declared for each of Level I and II Boys' and Girls'. Medals shall be presented to the first two individuals in each category and ribbons shall be presented to the third, fourth, fifth, and sixth place individuals in each category.

COSSA SOCCER

1. The F.I.F.A Rule Book shall be used to govern COSSA play.
2. a) Referees should be registered officials from the host District.
b) Soccer Games **MUST** have 3 qualified (certified) officials to referee both semi-finals and finals (one referee and two lines people).
3. 40 minute halves will be used for Senior competition and 30 minute halves for Junior competition.
4. The tournament shall be single elimination. (Two teams entered from each district).
5. **Ties:** All soccer games tied at the end of regulation time will be broken by playing two ten minute golden goal periods. If the tie continues, it will be broken by five penalty shots by each team, each team using five different players who were playing at the end of the overtime. If the tie still continues, penalty shots will alternate, using the remaining team members on the field at the end of overtime, until the tie is broken, with each team having taken an equal number of shots. In the event that a team playing with fewer than eleven players because of disqualification, substitution for other than those already in the "kick off" may be made (except for the ejected players).
6. Substitutions shall only be made (a) after a goal, (b) at the end of half time, (c) after a goal kick, (d) between overtime periods, (e) at the referee's discretion, (f) to be allowed on your throw in
7. Any player receiving a yellow card must be replaced at that time and that player may be substituted back in the game at the next appropriate time.
8. Any player receiving 2 yellow cards or a red card in the same game will be ejected from that game plus suspended from the next game.
9. Yellow and Red cards carry over from league and playoff games to COSSA. Kawartha and Quinte District Convenors shall provide this information to the COSSA Convenor.
10. The girl's soccer championship not to be played on the same day as East Regional Track and Field Meet.
11. The tournament shall begin no earlier than 10:00 AM.

COSSA SWIMMING

1. COSSA Swimming championships shall follow the same divisions as OFSAA Swimming championships (i.e. Senior and Open), for Individual events only.
2. **MEET STRUCTURE**-All the events are timed finals. If there is a tie in times for medal places, a swim off will be held at the end of the meet.
A scratch meeting will be held prior to the meet.
3. **ENTRIES:-**
 - (a) The Districts may enter: 8 individuals in each individual event and six relay teams in each relay event.
 - (b) A competitor may enter a maximum of four events, and if he or she is entered in the maximum, at least one event must be a relay.
 - (c) Individual schools may enter a maximum of four competitors in each individual event, and two relay teams in each relay event.
 - (d) Eight competitors may be entered as a relay team, and any four may swim in the event.
 - (e) The meet will be conducted according to the latest C.A.S.A. Rule Book.
 - (f) Time standards shall be used as a requirement for entry to OFSAA, and the time to be that of the 20th place finisher in that event at the OFSAA meet the previous year.
4. **EXPENSES**- An entry fee shall be charged which shall be sufficient to cover operating costs of the tournament.
5. **ELIGIBILITY-**
 - a) Only bona fide members of a school team, which is coached/supervised by a staff member from that school, may participate.
6. **SCORING**-Points shall be scored toward school championships as follows: Individual Events: 1st-12 pts, 2nd-10, 3rd-8, 4th-7, 5th-6, 6th-5, 7th-4, 8th-3, 9th-2, 10th-1 pt. Relay Events count double the above points.
7. **AWARDS**-COSSA medals shall be presented to 1st and 2nd place only. Ribbons shall be presented from 3rd to 6th place finishers.
8. Team Championship trophies shall be presented to Womens' Team Championships, Mens' Team Champions, and the OVER-ALL Champions.
9. In order for a swimmer to compete in an event at OFSAA the swimmer must compete in that event at COSSA. All entries for OFSAA will come from COSSA championships. (The COSSA champion and any other swimmer who has met the qualifying time at COSSA, KAWARTHA or BAY OF QUINTE only shall qualify for OFSAA)
10. COSSA swimming championships will follow the OFSAA Sport Regulations for Swimming
11. **Classification of Swimmers**
 - a) A **NOVICE** swimmer is to be under the age of 16 as of August 31 of the present school year. They may be in their first year of high school swimming and who have never been registered with a SNC Swim Club
 - b) A **JUNIOR** swimmer is to be under the age of 16 as of August 31 and who has not been registered as a competitive swimmer with a SNC Swim Club two years prior to entry to secondary school. A swimmer who is eligible for swimming on a junior relay team must not have been registered as a competitive swimmer with a SNC Swim Club in the last year, and is under the age of 16 as of August 31 of the current school year.
 - c) A **SENIOR** swimmer is to be under the age of twenty (20) as of August 31, and who has not been registered as a competitive swimmer with a SNC Swim Club in the last year.
 - d) An **OPEN** swimmer is to be under the age of twenty (20) as of August 31 and who has competed for and/or

trained with a SNC club or equivalent as of September 1st of the year prior to the current school year shall be eligible to compete in the Open Division only provided that he /she is a bona fide member of the school team.
e) SENIOR relays must consist of any combination of senior or open level swimmers.

Schedule of Events (Boys , Girls)

a) Novice 50m Freestyle, 50m Backstroke, 50m Breaststroke, 25m Butterfly, 200m Freestyle relay, 200m Medley relay.

b) Junior 50m Freestyle, 100m Freestyle, 50m Backstroke, 50m Breaststroke, 50m Butterfly, 100m Individual Medley, 200m Freestyle relay, 200m Medley relay.

c) Senior 50m Freestyle, 100m Freestyle 200m Freestyle, 100m Backstroke, 100m Breaststroke, 50m Butterfly, 100m Individual Medley, 200m Freestyle Relay, 200m Medley Relay

d) Open 100m Freestyle, 200m Freestyle, 100m Backstroke, 100m Breaststroke, 100m Butterfly, 200m Individual Medley, 400m Freestyle Relay (Exhibition)

Guidelines for COSSA Convenor

1. Use an appropriate meet manager program for entries and results
2. Starters, Referees, Clerk of the Course, Marshaller, Place Judge, and Stroke and Turn Judge should have qualified officials or have previous experience officiating swim meets.
3. Should provide 3 timers per lane.
4. Ensure a false start rope is in place and assign responsibility for that position.

COSSA TENNIS

1. Each District of COSSA shall be represented by three teams in each of the following categories: Girls' Singles, Boys' Singles, Girls' Doubles, Boys' Doubles, and Mixed Doubles. A competitor may enter only one of these.
2. The draw shall be a modified double elimination tournament.
3. Schools that qualify players to COSSA must pay entry fees unless they make arrangements for substitution with the next qualifier.
4. Matches are to be 8 game prosets, no advantage scoring, with a twelve (12) point tie breaker at Seven (7) all. The final match on the undefeated side may be extended to 2 of 3 sets at the discretion of the convenor upon considering the time, size of draw and weather.
5. If a match goes to three sets, the third set, if played out to 6-6, should be decided with a twelve point tie-breaker.

COSSA TRACK AND FIELD

1. The COSSA meet shall be held on an all-weather track and field facility on a date suitable for the OFSAA entry deadline. The meet shall begin at 9:30 AM.
2. To be eligible to compete at COSSA, an athlete MUST be eligible under COSSA rules and regulations. This means they must have successfully competed (time, distance, or height) at their District meet and legally qualified for entry to COSSA.

A competitor must not have competed for other than his/her school in a Track and Field meet from the period of May 1st to the date of the COSSA Track and Field Meet. Competitors who represent Canada or Ontario in a Track and Field Meet during this period shall be excused from this limitation of competition.

AGE CLASSIFICATIONS:

COSSA will conform to OFSAA age classifications for competition.

5. EVENTS :

COSSA will conform to OFSAA events, distances, heights and implement weights.

6. Competitors in both track and field events must compete in their school's uniform or a neutral top (ie PE uniform , white shirt - NO cutoffs or logos). Relay team members must wear identical tops. School, association, and OFSAA logos are the only acceptable insignia allowed during competition. Failure to abide by this regulation will result in disqualification.

7. There shall be two adult (non -secondary school students) officials at each field event except the Pole Vault and High Jump. In the Shot Put, Discus, and Javelin events, one adult shall be in the field.

8. The I.A.A.F. Rules for Track and Field must be followed, subject to these changes approved by COSSA:

- a) There shall be two teams of Track and field officials for simultaneous backstretch and front stretch events.
- b) There should be one Track Referee and one Field Referee (if possible, two Field Referees, one(1) for jumping and (1) for throwing events).
- c) The Convenor(s) shall supply Judges and four Track Marshals
- d) Track and Field officials should be suitably attired.
- e) A Jury of Appeal, shall be set up in advance at the COSSA meet to deal with disputes on the day of the meet. Disputes shall be handled according to the I.A.A.F. handbook.

Entries:

- a) Top 8 successful finishers in each event, at their District Championships, shall be entered at COSSA

If only 8 are entered from district meets, it shall be run as a FINAL.

- b) Schools may qualify two (2) relay teams. Each team will count for points towards the team championships.
- c) Entries for the COSSA meet shall be sent to the Entries Convenor no later than Monday prior to the meet.
- d) District meet results & entries to COSSA are to use compatible computer programs (Hy-Tek Meet Manager)

Qualifying and Seeding :

- a) Performances at District Meets will be used for seeding purposes
- b) **Scratch Rule** - once the meet begins, any athlete who scratches from a final after qualifying in heats of the 100m, 200m, or sprint hurdles will be ineligible to compete in any further events during that day of competition.

Eight (8) Lane Track**(Sprint Hurdles, 100m, 200m)**

- i) Two heats of 8 runners with the first 2 places in each heat plus the next 4 fastest times advancing to the final.
- ii) **Seeding** - the runners will be placed in the heats using the following format, which is based upon seed times submitted from the district meets with '1' being the fastest and '16' being the slowest.

Heat #1 - 1,4,5,8,9,12,13,16**Heat #2 - 2,3,6,7,10,11,14,15**

In the heats, runners shall be placed randomly in all eight lanes.

In the **FINAL** - the top two runners in each heat shall be randomly placed in lanes 3,4,5, and 6. The remaining runners shall be randomly placed in lanes 1,2,7, and 8. (If conditions warrant, the Head Track Referee has the authority to change the lane assignments.

- iii) Ties in heat times qualifying to the final will be broken as follows:

- 1) better placing in the same heat with identical times;
- 2) better placing in different heats with identical times;
- 3) the runner in the faster heat.

(400m , 400m Hurdles)

- i) These events will be run as timed section finals. There will be two sections of 8 runners in each event with the final placing based on times.
- ii) The top 2 runners from each district plus the next 4 fastest times shall be placed in the second timed section. The remaining runners shall be placed in the first timed section.
- iii) In both timed sections, runners will be randomly placed in all eight lanes.
- iv) If a tie occurs in times from different sections, the runners will both be given the same placing. The runner from the second timed section will advance to the regional meet. If the runners are still tied in times and places, then the qualifier shall be decided by drawing lots. There will be **NO RUNOFFS**.

(800m)

- i) The 800m will be run as a box start with a one (1) turn stagger.
- ii) Seeding - runners will be designated to a box based on random draw.
- iii) Four (4) runners will be assigned per box (a box = 2 lanes)

(1500m, Open 2000m Steeplechase)

- i) The runners shall be placed on the starting line based upon random draw for position.

(3000m)

- i) The 3000m shall be run from a box start with a one (1) turn stagger.
- ii) Seeding - Runners will be designated to a box based on random draw.
- iii) Four (4) runners will be placed in each box. (a box = 2 lanes)

(Relays - 4 x 100m and 4 x 400m)

- i) These events to be run as timed section finals. The same procedure for breaking ties in the 400m shall be used in the relays.
- ii) Determination of heats and lanes to be done using the same format as described in individual events.

(Field Events)

- i) The order in which the competitors take their trials shall be drawn by lot, prior to the start of the competition by the entries chairperson.
- ii) Top eight (8) after 3 rounds in the LJ, TJ, DT, JT, and SP shall receive an additional 3 trials. The order of the top 8 after the first 3 rounds is to be reversed (8th -1st where 8th place competes first and 1st place competes last) for the final 3 rounds.
- iii) Ties in Vertical Jumping Events - if this occurs in the final qualifying or first alternate position for the Regional Meet, the following tie breaking procedure will take place.
The competitors involved in the tie will break the tie with a jump-off immediately after the conclusion of the event. Heights attained during the tie-breaking process shall not be reflected in the final results of the competition.
- iv) There shall be two (2) high jump pits at the COSSA meet where possible.

(Throwing events) -

- a) any implement wishing to be used in competition MUST be weighed in. Once an implement is approved, any competitor may use it.
- b) ALL throwing implements brought to COSSA must be weighed in between 0900 and 1030 . They are to be turned into the Track and Field officials. Other weigh in times may be established by the convener.
- c) There shall be a supervised area for practising Field Events
- d) No practice shall be allowed during competition
- e) Any individuals breaking these rules will be disqualified
- f) The COSSA Convenor shall make provisions for on regulation throwing implement for each of the classifications.
- g) Rubber tipped cleats may be worn as footwear in the javelin unless the surface is all-weather, in which the maximum spike length is 6mm. No cleats may be worn on an all-weather surface.

11. Scoring - a) Team Champions will be determined using the following system when the meet is held on an 8 lane facility

1 st - 10 points	5 th - 4 points
2 nd - 8 points	6 th - 3 points
3 rd - 6 points	7 th - 2 points
4 th - 5 points	8 th - 1 point

b) Team Championships to be awarded to the school(s) which score the most points in each of the following categories :

- a) 'A' School (as defined by OFSAA)
- b) Girls Overall
- c) Boys Overall
- d) Overall Champions
- c) In the event that there are more than 3 competitors from a school placing, only the top 3 competitors placing will be used for scoring purposes. The next highest placed competitor will be moved up pointless.

12. Regional Qualifying

- i) COSSA hosts (8 lane track) - 6 entries , all events
- ii) COSSA not hosting (8 lane track) - 5 entries , all events

13. **First Aid** - There shall be qualified medical personnel on site
14. The COSSA convenor , at their discretion may call an organizational meeting to review the format and organizational structure of the COSSA meet.
15. **Finances** - each school will be billed for their entries following the meet through their Secretary- Treasurer.
16. **AWARDS** - Gold and silver medals to be awarded to first and second in each event. Ribbons to be awarded to 3rd through 8th.

TO IMPROVE THE OPERATION OF A TRACK AND FIELD MEET OFFICIALS

The officials will be a combination equally represented from each District.

A TRACK MEET WILL RUN MORE SMOOTHLY IF:

1. Officials are on time.
2. Officials know the rules pertaining to their event.
3. Officials know they can contribute to the efficient operation of the event.

TO ACHIEVE THESE GOALS:

A set list of officials should be drawn up for use at all COSSA meets. After a few weeks, officials will become familiar with their roles, and officiating will become more standardized from year to year.

TO MAKE THE DUTIES MORE EQUITABLE:

1. The field Event Judges will handle all of the Boys and Girls age groups in that event.
2. Relay Judges will act as Hurdle Judges in the morning.
3. There will be an official in charge of Hurdles and the Hurdle Crew.

TO HAVE THE MEET RUN ON TIME:

1. Each official must draw equipment, where necessary, and report prior to the scheduled time of the event.
2. Be prompt. A missing or late official delays an event unnecessarily and makes the meet run longer.
3. There must be co-operation between the Starter and the Finish Line Personnel. Each should challenge the other by the speed with which each is ready for the next heat. This can be accomplished by:
 - (a) **THE TRACK MARSHAL AND STARTER** -The Marshal moves the next heat onto the track as soon as the previous heat has left the Start. The Starter completes the instructions to the competitors by the time the Finish Line People have cleared away the previous Heat.

4. THE FINISH LINE PEOPLE

The FINISH LINE JUDGE writes down the names or numbers of the competitors using the following method: Judge #1 picks 1st, Judge #2 picks 1st and 2nd, Judge #3 picks 2nd and 3rd, Judge #4 picks 3rd and 4th, Judge #5 picks 4th and 5th, and Judge #6 picks 5th and 6th.

THE FINISH LINE JUDGE - writes down the order of finish on the score sheet obtained prior to the event. The score sheet is handed to the RECORDER. (The Assistant Timer provides the Recorder).

CHIEF TIMER reads all the watches (see notes on timing) and records on a slip of paper the time or times for each place and gives the slip of paper to the Recorder.

THE FINISH LINE PERSONNEL are now ready for the next heat.

5. Communications between CLERK and ANNOUNCER or between FIELD EVENT JUDGES and ANNOUNCER can be improved with the use of walkie-talkies or a Runner.

6. NOTES ON TIMING

HEATS ... 3 watches on first, 1 watch on second, 2 watches on third and fourth, 1 watch on fifth and sixth.

Finals ... 3 watches on first and second, 1 watch on third, fourth, fifth and sixth.

Hand timed races up to 20km: any time over the tenth of a second gets rolled up (i.e. 10:09 sec is read 10:1, 10:10 sec is read 10:1, and 10:11 sec is read 10:2).

N.B. All times should be recorded before the watches are cleared.

COACHES

COACHES can contribute to the efficient running of the Meet by:

1. Knowing the rules
2. Knowing how competitors qualify to go on
3. Having competitors ready for their events when called,
4. Realizing that when a competitor is simultaneously in a Field Event and a Track Event, the Coach can send another student to the Track Marshalling area to check in for the competitor and obtain the lane draw. Then, on third (last) call, or when the heat before is going on the Track, the competitor can quickly go to the Track competition from the Field Event.

COMPETITORS

1. Athletes must be made aware of the importance of being on time for an event.
2. Athletes should warm up ahead of time and report on the first call to the official in charge of the event.
3. Where a competitor is in a Track event and a Field Event at the same time, he or she should compete in as many rounds of the Field event as is possible first. The official in charge can change the order of competition in a round of a Field event to accommodate an athlete taking part in another event, but he cannot allow a trial if the competitor is not present for that round when called.

COSSA VOLLEYBALL**1. Classification of Schools**

a) Schools shall be classified as "A", "AA", or "AAA" based on OFSAA classifications.

Any team in any member school, with district approval, may elect to compete in a higher classification.

COSSA Championships

a) The rules of OVA Youth shall be used including the libero, 60 sec time out , 12 substitutions, tie breaking procedure.

c) **Net Heights** Junior Boys: 2.35m Senior Boys: 2.43m

Junior Girls: 2.13m Senior Girls: 2.24m

d) A minimum warmup of 15 minutes shall be allowed for any team arriving at a court for the first time during the tournament.

e) All team members shall be attired in identical shirts and same colour shorts. The number on the shirt must be visible

f) Two carded adult officials (non-student) per court must be used for all matches at all COSSA Volleyball tournaments, except in the 'A' division where only one carded official must be used every time there is less than 4 teams involved in the championship.

g) All COSSA Championships will be played on a centre court.

h) The "A", "AA" and "AAA" COSSA tournaments shall use a four team round robin format with **two teams from each district**. Matches shall be best 2 out of 3 - 25 point games no cap with the third game to 15 points with no cap . If one district has only one eligible team in a division, the other district may send up to three teams to complete the four team tournament. This will seed teams for the playoffs.

The COSSA tournament schedule should alternate each year.

Even years, the format should be:

Rd 1 K1 vs Q2

Rd 2 K2 vs Q1

Rd 3 K1 vs Q1

Rd 4 Q2 vs K2

Rd 5 K1 vs K2

Rd 6 Q1 vs Q2

Odd years, the format should be:

Rd 1 Q1 vs K2

Rd 2 K1 vs Q2

Rd 3 K1 vs Q1

Rd 4 Q2 vs K2

Rd 5 Q1 vs Q2

Rd 6 K1 vs K2

Playoff format : 1st in the round robin plays 2nd in the round robin for the COSSA Championship.

Matches will be a best 2 out of 3 with the first two games being to 25 points no cap. The third and deciding game will be to 15 no cap .

i) If a district does not have an entry at any one level, the other district's champion will represent COSSA at the appropriate OFSAA level as the COSSA Champion.

j) Convenor must supply all minor officials, including linesman, for COSSA Championships.

OVA Tie-Breaking Procedures - Youth Competition

If two or more teams, within a pool, are tied at the end of the preliminary round, the following criteria will be applied in order until all ties are broken, and all tied teams ranked. This means that if there is a tie among teams X, Y & Z and criteria b) is able to determine X as first, Y as second and Z as third, then no further criteria is needed. However, if criteria b) determines X as first (or third) and there is still a tie between Y & Z, then the ranking of the remaining teams will be determined by proceeding to criteria c) and so on, if necessary. Continue through the sequence of criteria and DO NOT start at a) again.

(a) The team having the best ratio of won/lost matches, considering matches played between the tied teams, will be ranked higher.

(b) The team having the best ratio of won/lost games, considering matches played between the tied teams, will be ranked higher.

(c) The team having the best ratio of won/lost games, considering all matches of the round, will be ranked higher.

(d) The team having the best ratio of points for/against, considering games played between the tied teams, will be ranked higher. However, if this criteria would eliminate a team or teams from the playoffs, see the notes below.

(e) The team having the best ratio of points for/against, considering all games played during the round, will be ranked higher. However, if this criteria would eliminate a team or teams from the playoffs, see the notes below.

(f) A coin toss by the tournament director and head official in the presence of team representatives.

NOTES: For criteria (d) and (e) only, after the sequence of (a), (b) and (c) has been followed.

If two teams are tied for one playoff spot, one rally point game (to 15 points) between the tied teams will be played with the winner advancing to the playoffs.

In the case of a **3-way tie for one playoff spot**, the team with the best points ratio will be designated team "A". Teams "B" and "C" will play a rally point game with the winner playing another rally point game against team "A" for the playoff spot.

In the case of a **3-way tie for two playoff spots**, points ratio will be used to determine the first position. The other two tied teams will play a rally point game for the second playoff position.

Format and Protocol for Tie Break Games: 15 point rally scoring; change of courts at 8 points; winner must obtain a margin of at least 2 points - no point cap; a 5 minute common and general warmup only - no net warmup (no attacking nor serving).

5. Awards - COSSA gold medals shall be awarded to the COSSA Champions and COSSA silver medals to the runners-up.

Finances -Cost of medals and officials shall be recovered in the form of the entry fee, payable the day of the Championships

The tournament shall begin no earlier than 10:00 AM.

COSSA WRESTLING

1. As determined by the COSSA Executive, the date of the COSSA Wrestling Championships shall be set in the week preceding the OFSAA Declaration date.
2. There shall be one open classification for both schools and age.
3. The current OFSAA rule book will be followed. This will include rules, weight classes, and proper wrestling uniforms.
4. The top four (4) competitors from each District in each weight class are eligible for COSSA.
5. COSSA format shall be a bracket draw with consolation .

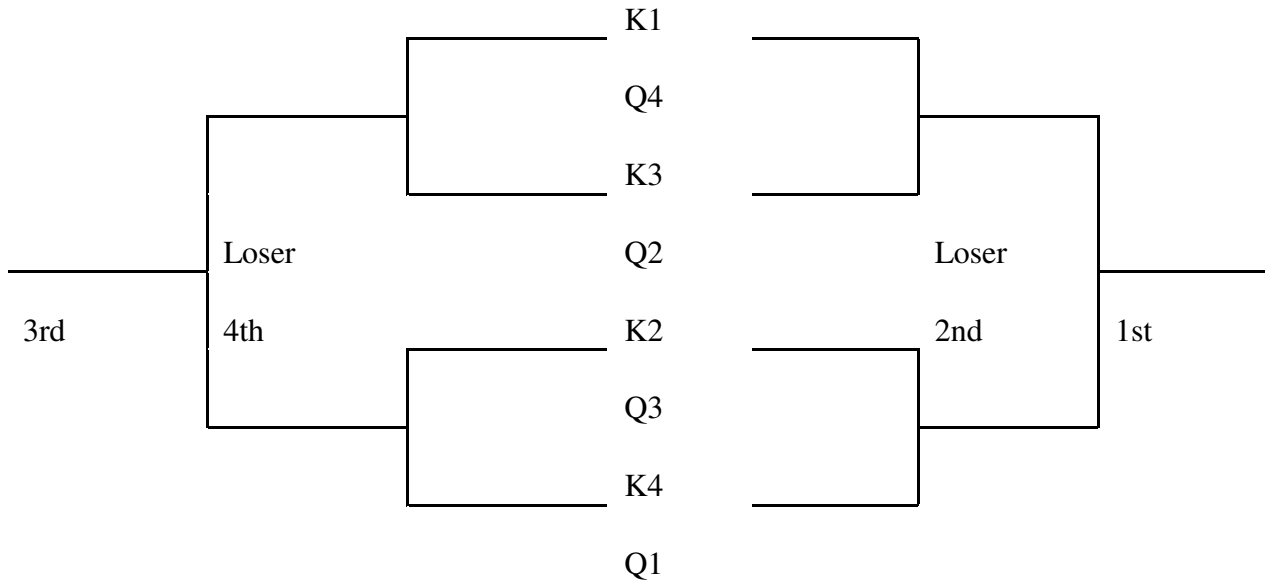

6. The team points will be as follows: 1st – 10, 2nd - 6, 3rd - 4, 4th - 1
7. Three wrestlers points will count for the team trophy.
8. If one district does not have 4 qualifiers in any class the other district's 5th and 6th place finishers will be permitted to advance and assume the appropriate positions on the draw sheet.
9. Prior to the district wrestling championships, all competitors must have participated in at least 2 meets. Any exceptions, i.e. injuries must be forwarded to the district convenors 1 week prior to the district meet.
10. The tournament shall begin no earlier than 10:00 AM. Weigh-ins and coaches meetings shall be in advance of the tournament.
11. a) each school will have a coach from another near-by school designated to attend an official weigh-in at the assigned school between the times of 3:00 pm - 5:00 pm.
 b) in special circumstances (e.g. rural location of school, inclement weather, or any other extenuating reasons), the school principal, vice-principal, and athletic director can assist in this procedure if a coach from a near-by school can not attend. Please note, this special circumstance definitely applies to Haliburton Highlands Secondary School, Fenelon Falls Secondary School, and North Hastings High School.
 c) A wrestler must weigh-in (with as many opportunities as necessary) before 5 pm of the weigh-in date.

d) Each school shall use the “**Weigh-in Verification & Entry Form**” attached to this document to officially submit entries to the COSSA Wrestling Championships. A summary of confirmed and scratched entrants shall be e-mailed to the COSSA Wrestling Convenor and Drawmaster by 6:00 pm on the date of the weigh-in. The Convenor shall e-mail confirmation of summaries upon receipt. A **paper copy** of this form, completed [*preferably typed*] and properly signed & dated by both the home coach and designated witness, shall be submitted to the COSSA Wrestling Convenor on or before the day of the COSSA Wrestling Championships.

12. Official Skin Check Procedure

- a) Coaches shall be responsible for ensuring their wrestlers are free from communicable skin diseases for competitions.
- b) An athlete shall be excluded from competition for any potentially infectious skin condition including, but not limited to, fungal [*e.g., tinnea (ringworm)*], bacterial [*e.g., Staphylococcus spp., Streptococcus spp., impetigo*], viral [*e.g., Herpes Simplex*], or weeping lesions expressing pus or yellowish fluid.
- c) A doctor’s note, typed on his/her official letterhead, shall be required, and presented to the Convenor prior to the COSSA Wrestling Championships, for exemptions for any non-contagious skin rash [*eg., eczema*].
- d) Skin conditions such as mat burns, cuts, severe acne, boils, etc “*may*” be permitted, at the discretion of the Convenor, provided they present no danger to the athlete himself/herself nor to others and can be safely covered with athletic tape [*where practical or necessary*].
- e) In the event a coach or referee is concerned about a potential infectious skin condition, including those covered by tape or bandages, on a wrestler, a **written** protest shall be filed with the Convenor **prior** to the bout. With the assistance of 2 **neutral** coaches [*one from Kawartha & one from Bay of Quinte*], the Convenor shall render a decision regarding exclusion of the athlete.