

ASSEMBLY

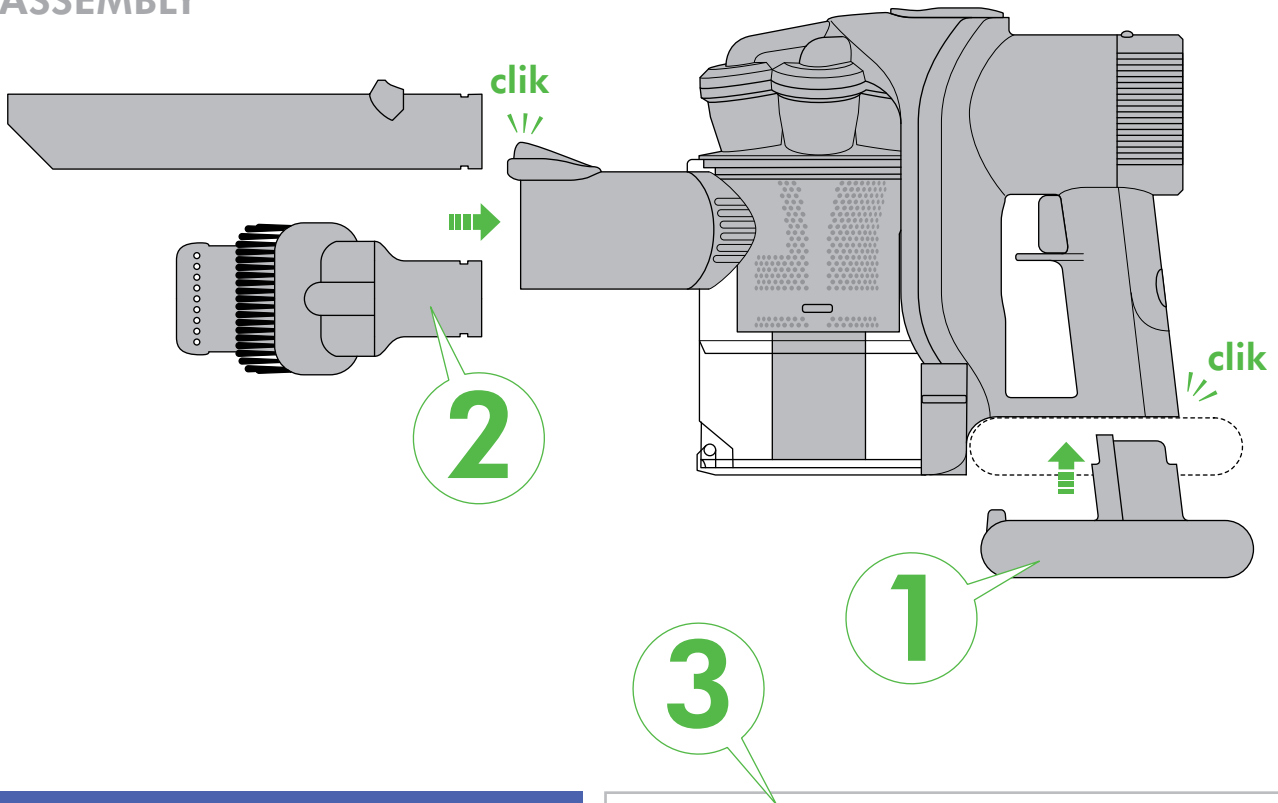

WASH FILTER
Wash your filter with cold water regularly or as required.

The diagram shows the charging process:

- The power cord is plugged into a wall outlet.
- A battery level gauge is shown with a green arrow indicating the charge level. The gauge has numbers 1 through 12. A green arrow points from 12 down to 3, with "3.5 hrs" written next to it.
- A green oval icon is labeled "FULLY CHARGED".

REGISTER YOUR 2 YEAR GUARANTEE TODAY

The diagram shows the dust bin being inserted into the main unit. A circular callout with the word "MAX" and three horizontal bars indicates the maximum fill level for the dust bin.

Your Dyson handheld vacuum will be covered for parts and labour for 2 years from the date of purchase, subject to the terms of the guarantee.

If you have a query about your Dyson handheld vacuum, call the Dyson Customer Care Helpline quoting the serial number and details of where/when you bought the Dyson handheld vacuum. The serial number can be found on the rating plate which is behind the filter.

Most queries can be solved over the phone by one of our trained Dyson Customer Care Helpline staff.

Visit our website to register your full parts and labour guarantee online (Australia only).
www.dyson.com.au/register

Note your serial number for future reference



This illustration is for example purposes only.

IMPORTANT SAFETY PRECAUTIONS

READ ALL INSTRUCTIONS BEFORE USING THIS APPLIANCE

When using an electrical appliance, basic precautions should always be followed, including the following:

WARNING

TO REDUCE THE RISK OF FIRE, ELECTRIC SHOCK OR INJURY:

1. Use only as described in this Dyson Operating Manual. Use only Dyson recommended attachments.
2. Do not use outdoors, on wet surfaces or near a naked flame.
3. Do not use to pick up flammable or combustible liquids, such as petrol or use in areas where they may be present.
4. Do not pick up anything that is burning or smoking, such as cigarettes, matches or hot ashes.
5. Do not use without the clear bin and the filter in place.
6. Children should be supervised to ensure they do not play with the Dyson handheld vacuum.
7. Do not use with damaged cable or plug. If the Dyson handheld vacuum is not working as it should, has been dropped, damaged, left outdoors or dropped into water, contact the Dyson Customer Care Helpline.
8. This Dyson handheld vacuum is not intended for use by persons (including children) with reduced physical, sensory or mental capabilities, or lack of experience and knowledge, unless they have been given supervision or instruction concerning the use of the Dyson handheld vacuum by a person responsible for their safety.
9. Do not put any object into openings. Do not use with any opening blocked; keep free of dust, lint, hair and anything that may reduce air flow.
10. Keep hair, loose clothing, fingers and all parts of body away from openings and moving parts.
11. Use extra care when cleaning on stairs.
12. Use only the charger supplied with the product to recharge.
13. Do not charge the unit outdoors, in a bathroom or where it may be wet.
14. Do not handle charger, including the charger plug and the charger terminals with wet hands.
15. Do not unplug the charger by pulling on the cable. To unplug, grasp the plug, not the cable.
16. Do not incinerate the Dyson handheld vacuum even if it is severely damaged. The batteries may explode in a fire.
17. Do not use with an extension cable.
18. Unplug the charger from the supply before maintenance.

SAVE THESE INSTRUCTIONS

THIS HANDHELD VACUUM IS INTENDED FOR DOMESTIC HOUSEHOLD AND CAR USE ONLY.

3 EASY WAYS TO REGISTER YOUR 2 YEAR GUARANTEE

REGISTER ONLINE

Visit our website to register your full parts and labour guarantee online (Australia only).

www.dyson.com.au/register

REGISTER BY PHONE

Call our dedicated Helpline.

AU 1800 239 766
NZ 0800 397 667
SG 7000 435 7546
ID 021 707 39766

REGISTER BY MAIL

Complete and return the form to Dyson in the envelope supplied.



Do not use near naked flame.



Do not store near heat source.



Do not pick up water or liquids.



Do not pick up burning objects.

Looking for blockages

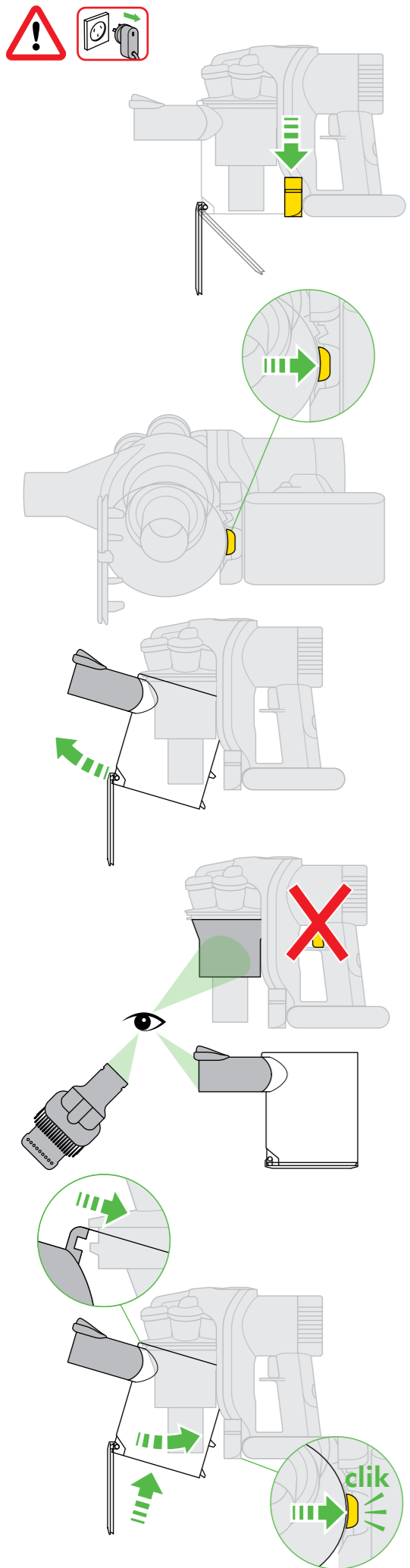

Power

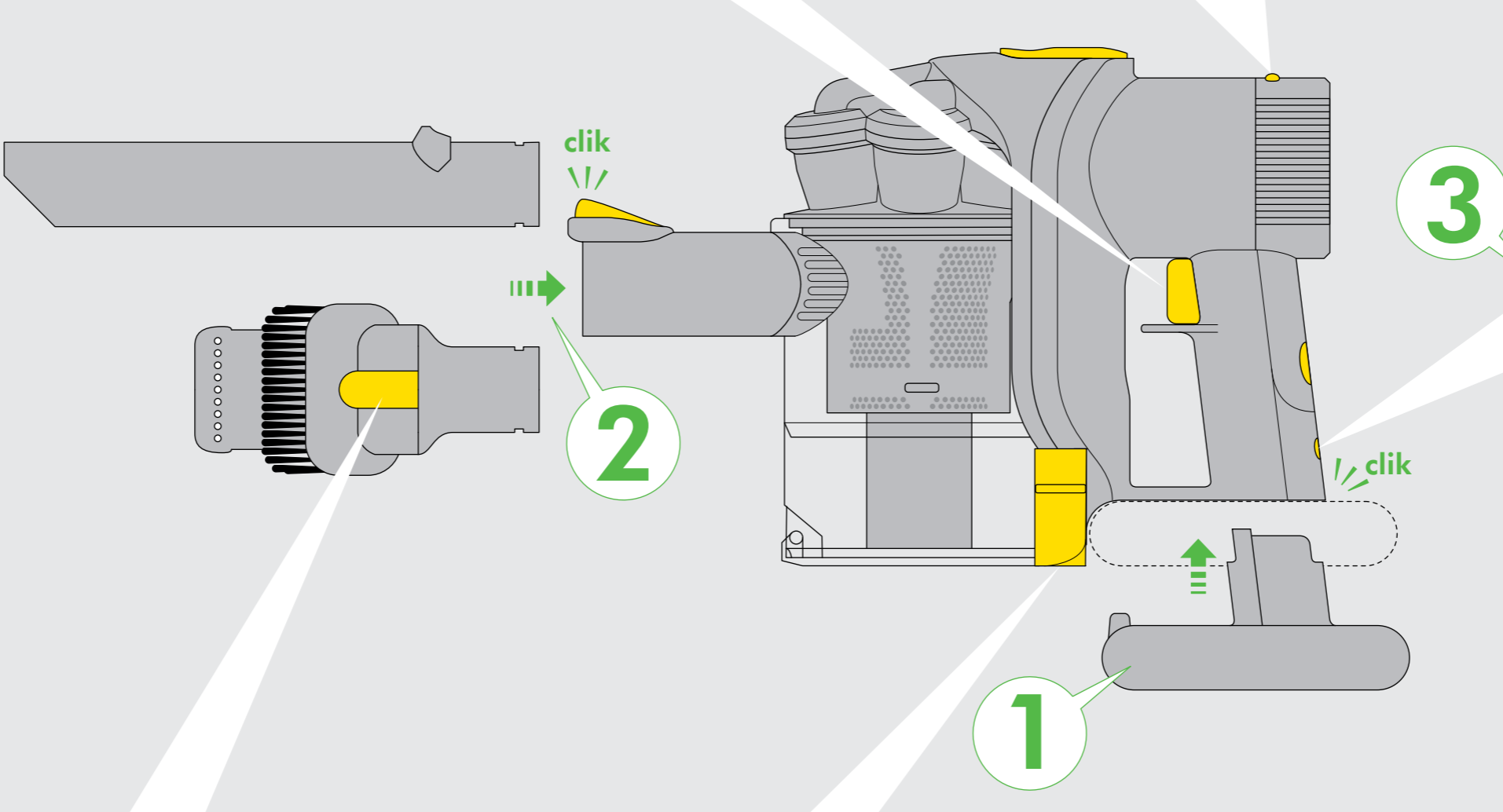
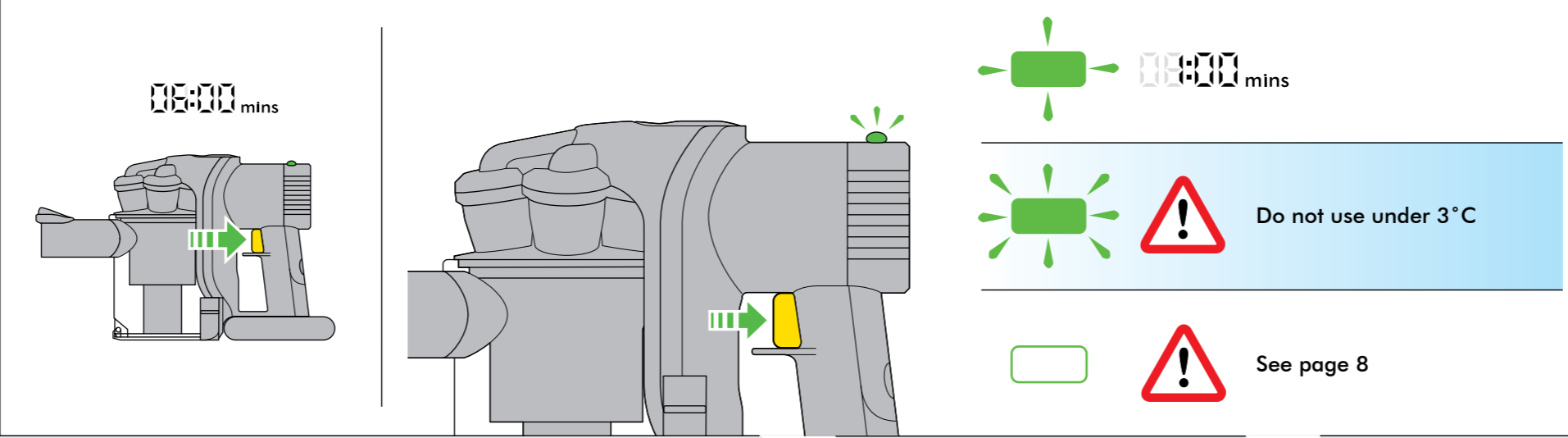

Charging

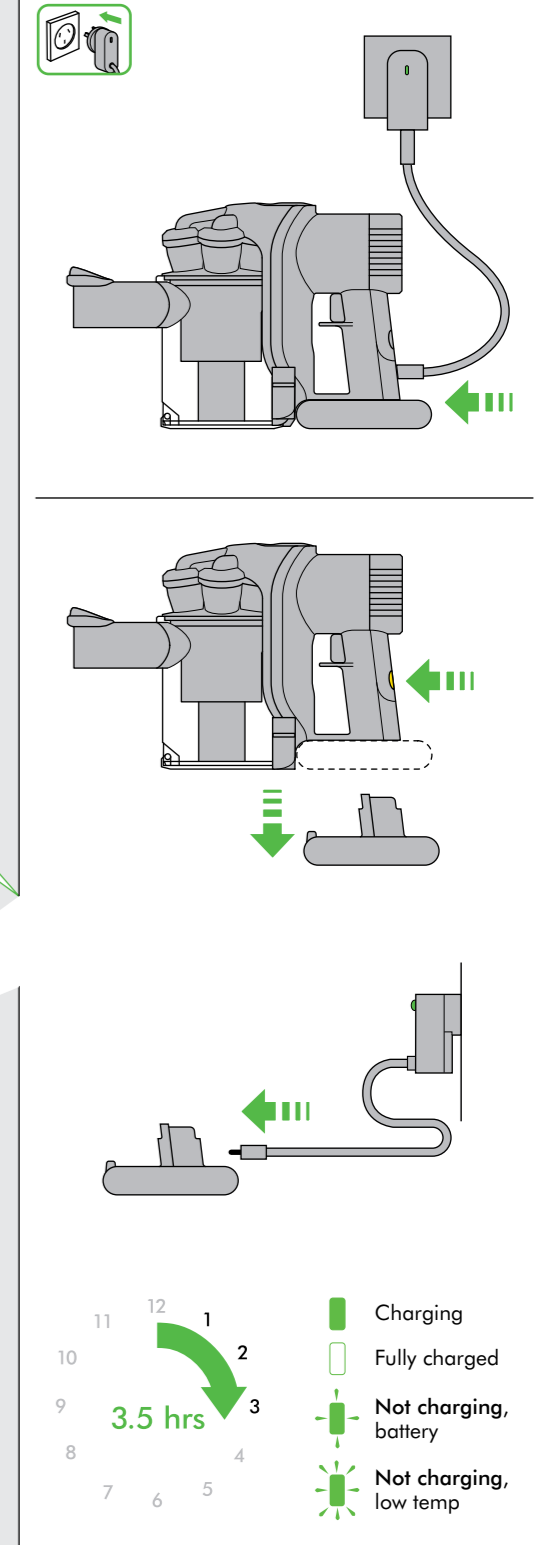

Tools

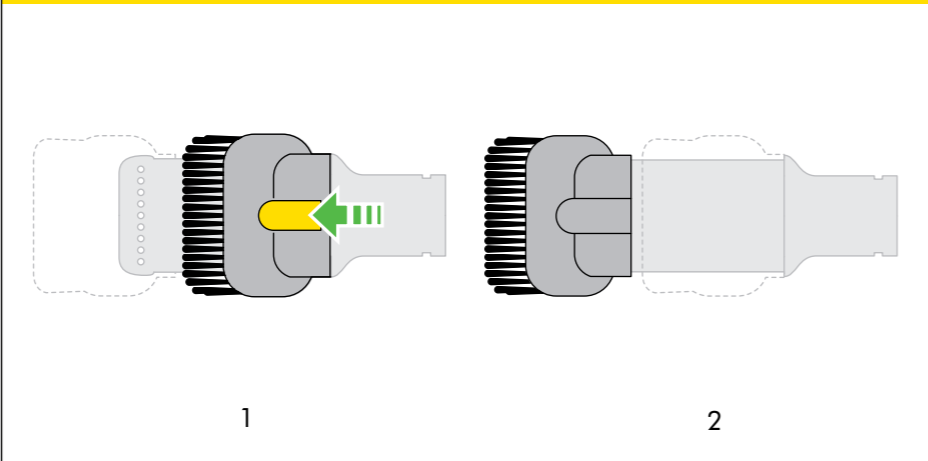

Emptying the clear bin

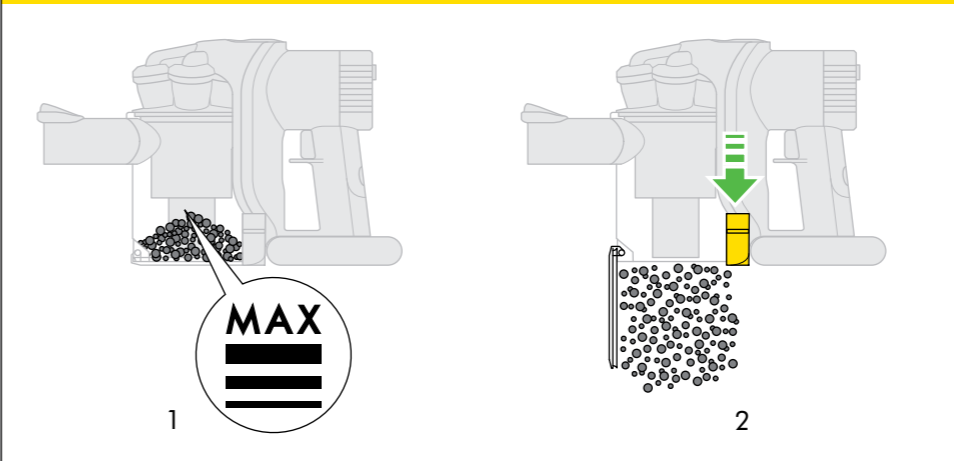

IMPORTANT!
WASH FILTER

Wash your filter with cold water regularly or as required.

IMPORTANT!

WASH FILTER



Wash your filter with cold water regularly or as required.

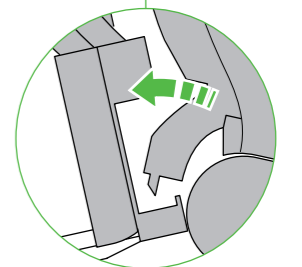
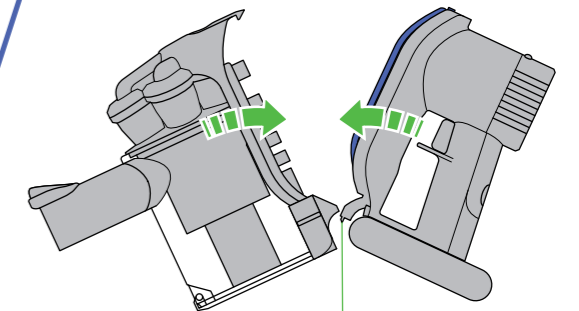
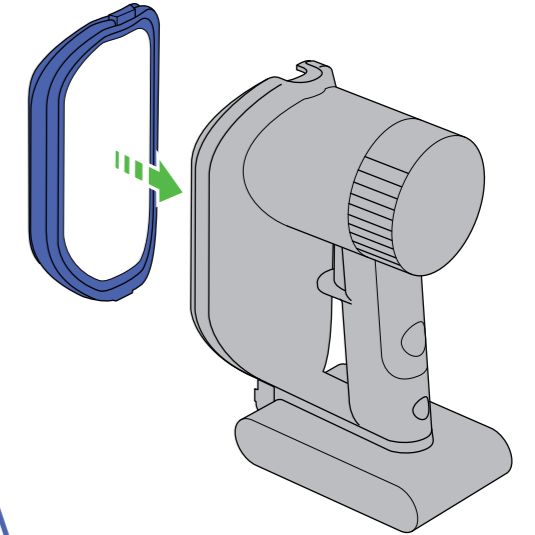
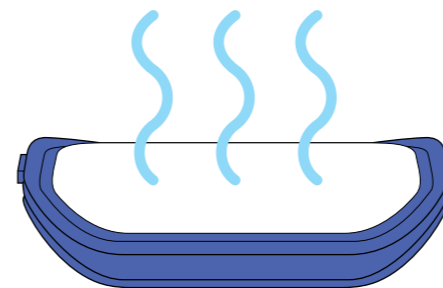
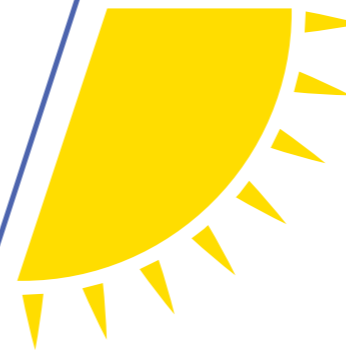
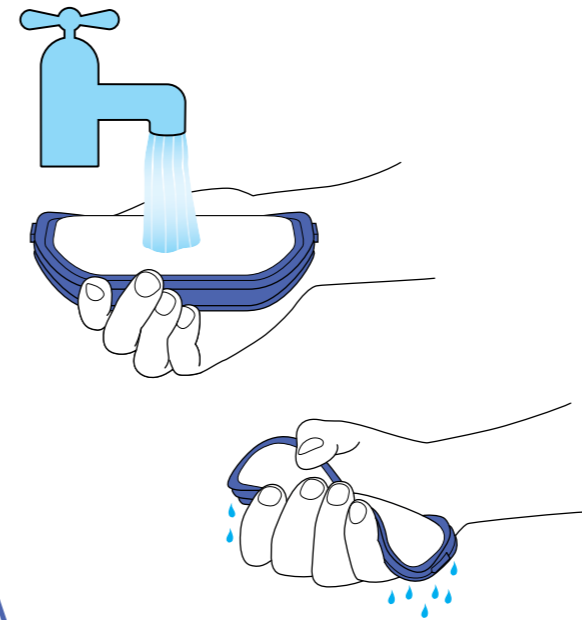
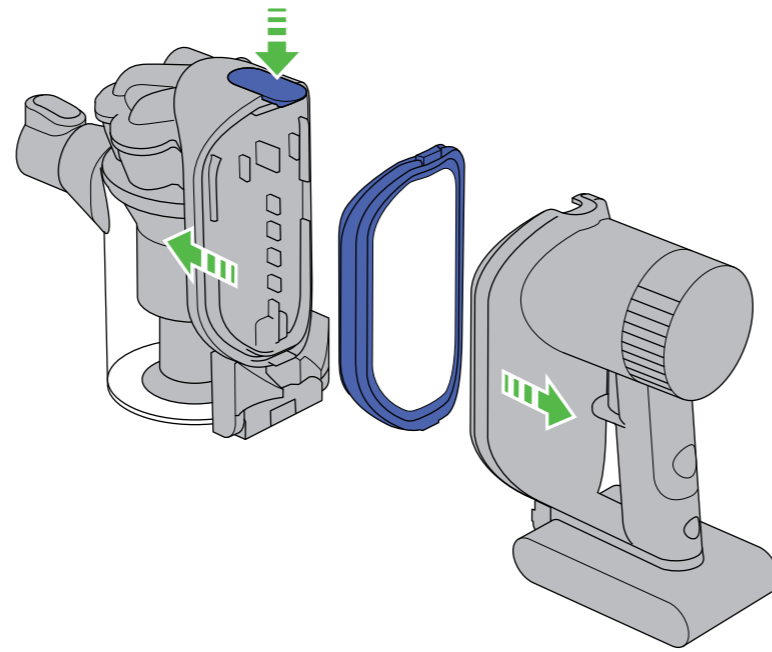
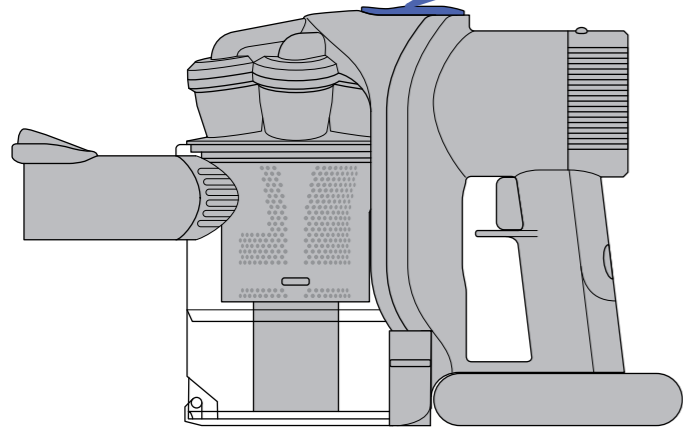

USING THE DYSON HANDHELD VACUUM



CAUTION:

- Dirt and debris may be released from the Dyson handheld vacuum if it is turned upside down. Ensure the Dyson handheld vacuum remains upright in use and storage.
- Do not operate the Dyson handheld vacuum while checking for blockages.

PLEASE NOTE:

- Do not carry out any maintenance or repair work other than that shown in this Dyson Operating Manual or advised by the Dyson Customer Care Helpline.
- This Dyson handheld vacuum is designed for domestic indoor and car use only. Do not use it while the car is in motion or while driving.
- Do not press down on the nozzle with excessive force when using the Dyson handheld vacuum as this may cause damage.
- If the motor overheats, the Dyson handheld vacuum will cut out automatically. Leave it to cool for at least an hour and check for blockages before restarting.
- Fine dirt such as flour or plaster dust should only be vacuumed in very small amounts.
- Consult your flooring manufacturer's recommended instructions before vacuuming and caring for your flooring, rugs and carpet.

TROUBLESHOOTING – DYSON HANDHELD VACUUM

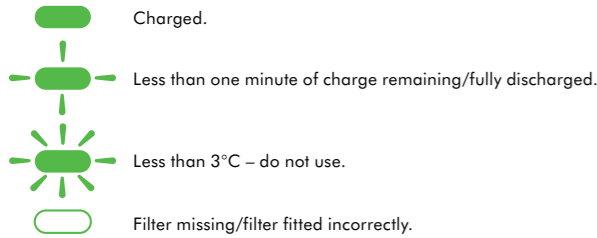

EMPTYING THE CLEAR BIN



CAUTION:

- Switch off the Dyson handheld vacuum and disconnect from charger before emptying the clear bin.
- Empty as soon as the dirt reaches the level of the MAX mark – do not overflow.
- To release the dirt, push the button at the side of the clear bin as shown.

PLEASE NOTE:

- Do not use the Dyson handheld vacuum without the clear bin in place.

CLEANING THE CLEAR BIN



CAUTION:

- Ensure the clear bin is completely dry before replacing.

PLEASE NOTE:

- To remove the clear bin, push the release button on the underside of the Dyson handheld vacuum as shown.
- Use only cold water to clean the clear bin. Do not use detergents, polishes or air fresheners.
- Do not put the clear bin in a dishwasher.

WASHING THE FILTER



CAUTION:

- Switch 'OFF' and disconnect from charger before removing the filter.
- Ensure filter is completely dry before refitting to the Dyson handheld vacuum.

PLEASE NOTE:

- This Dyson handheld vacuum has one filter, located as shown. It is important to check your filter and wash with cold water regularly or as required, to maintain performance. Please leave to dry completely for 12 hours.
- The filter may require more frequent washing if vacuuming fine dust.
- Do not use detergents to clean the filter.
- Do not put the filter in the dishwasher, washing machine, tumble dryer, oven, microwave or near an open flame.

LOOKING FOR BLOCKAGES



CAUTION:

- Switch off the Dyson handheld vacuum and disconnect from charger before looking for blockages.
- Beware of sharp objects when clearing blockages.
- Refit all parts of the Dyson handheld vacuum securely before using.

PLEASE NOTE:

- Clearing blockages is not covered by the Dyson handheld vacuum's guarantee. If any part of the Dyson handheld vacuum becomes blocked, it may overheat and then automatically shut off.
- Unplug the Dyson handheld vacuum and leave to cool down. Clear blockage before restarting.

CHARGING AND STORING THE DYSON HANDHELD VACUUM

The Dyson handheld vacuum will turn off if the battery temperature is below 3°C. This is designed to protect the motor and battery of your product. Do not charge the Dyson handheld vacuum and then move it to an area with a temperature below 3°C for storage purposes.

TROUBLESHOOTING – CHARGER

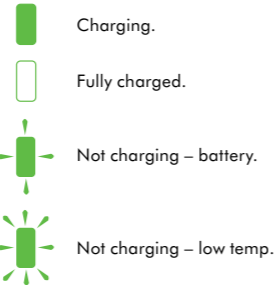

BATTERY SAFETY INSTRUCTIONS

Use only Dyson batteries and charging unit for the Dyson handheld vacuum. The battery is a sealed unit and under normal circumstances poses no safety concerns. In the unlikely event that liquid leaks from the battery do not touch the liquid and observe the following precautions:
Skin contact – can cause irritation. Wash with soap and water.
Inhalation – can cause respiratory irritation. Expose to fresh air and seek medical advice.
Eye contact – can cause irritation. Immediately flush eyes thoroughly with water for at least 15 minutes. Seek medical attention.
Disposal – wear gloves to handle the battery and dispose of immediately following local ordinances or regulations.



CAUTION:

The battery used in this device may present a risk of fire or chemical burn if mistreated. Do not disassemble, short contacts, heat above 140° F (60° C), or incinerate. Replace battery with a Dyson battery only, use of any other battery may present a risk of fire or explosion. Dispose of used battery promptly. Keep away from children. Do not disassemble and do not dispose of in fire.

- The battery must be removed from the Dyson handheld vacuum before it is scrapped.
- The battery is to be disposed of safely.
- The Dyson handheld vacuum must be disconnected from the supply mains when removing the battery.

The symbol  on the product or on its packaging indicates that this product should not be treated as household waste. Instead it should be handed over to the applicable collection point for the recycling of electrical and electronic equipment – this may be your local civic amenity site product. By ensuring this product is disposed of correctly, you will help prevent potential negative consequences for the environment and for human health, which could otherwise be caused by inappropriate waste handling of this product. For more detailed information about recycling of this product, please contact the Dyson Customer Care Helpline, your local authority civic amenity site product.

2 YEAR GUARANTEE - TERMS AND CONDITIONS

To help us ensure you receive prompt and efficient service, please register as a Dyson owner. There are three ways to do this:

- Online (Australia only) at customercare@dyson.com.au
- By calling the Dyson Customer Care Helpline.
- By completing and returning the enclosed form to us by mail. This will confirm ownership of your Dyson handheld vacuum in the event of an insurance loss and enable us to contact you if necessary.

DYSON CUSTOMER CARE

If you have a query about your Dyson handheld vacuum call the Dyson Customer Care Helpline and quote your serial number or contact us via the Dyson website. The serial number can be found on the main body of the handheld vacuum behind the filter.

Most queries can be solved over the phone by one of our Dyson Customer Care Helpline staff.

If your Dyson handheld vacuum needs a service, call the Dyson Customer Care Helpline so we can discuss the available options.

DYSON CUSTOMER CARE DETAILS

Any queries – just call the Dyson Customer Care Helpline

AU: 1800 239 766 (Mon-Fri 8:00am to 6:00pm EST, Sat-Sun 8:30am to 4:00pm EST) www.dyson.com.au
NZ: 0800 397 667 (Mon-Fri 8:30am to 5:00pm) www.dyson.co.nz
ID: 021 707 39766 www.dyson.com
SG: 7000 435 7546 www.dyson.com.sg

SUMMARY OF COVER

Terms and conditions of the Dyson 2 year guarantee.

- The guarantee becomes effective from the date of purchase.
- All work will be carried out by Dyson Appliances (Aust) Pty Ltd, Avery Robinson Ltd (New Zealand).
- Any parts replaced will become the property of Dyson Appliances (Aust) Pty Ltd.
- The repair or replacement of your Dyson handheld vacuum under guarantee will not extend the period of guarantee.
- The guarantee provides benefits which are additional to and do not affect your statutory rights as a consumer.
- You must provide proof of purchase before any work can be carried out on your Dyson handheld vacuum. Without this proof, any work carried out will be chargeable. Please keep your receipt.

WHAT IS COVERED

- The repair or replacement of your Dyson handheld vacuum if your vacuum cleaner is found to be defective due to faulty materials, workmanship or function within 2 years of purchase (if any part is no longer available or out of manufacture, Dyson will replace it with a functional replacement part).

WHAT IS NOT COVERED

Dyson shall not be liable for costs of repair or replacement of a product incurred as a result of:

- Normal wear and tear.
- Industrial use of the Dyson handheld vacuum such as vacuuming gyprock dust or builders dust may void your guarantee.
- Accidental damage, faults caused by negligent use or care, neglect, careless operation or handling of the Dyson handheld vacuum which is not in accordance with this Dyson Operating Manual.
- Blockages – please refer to the Dyson Operating Manual for details on how to unblock your Dyson handheld vacuum.
- Use of the Dyson handheld vacuum for anything other than normal domestic purposes.
- Use of parts not assembled or installed in accordance with the instructions of Dyson.
- Use of parts and accessories other than those produced or recommended by Dyson.
- External sources such as transit damage or weather.
- Repairs or alterations carried out by parties other than Dyson or its authorised agents.
- If you are in any doubt as to what is covered by your guarantee, please call the Dyson Customer Care Helpline on:
Australia 1800 239 766
New Zealand 0800 397 667
Indonesia 021 707 39766
Singapore 7000 435 7546

ABOUT YOUR PRIVACY

Dyson may use this information for future marketing and research purposes (including sending commercial electronic messages) and may disclose it to third parties for the purposes of providing the services you have requested or to our business partners or professional advisers. If you wish to access your personal information or see our full privacy policy, please contact us at customercare@dyson.com.au

CONFORMITY INFORMATION

A sample of this product has been tested and found to be in conformity with the following European Directive: 2006/95/EC Low voltage Directive, 93/68/EEC CE Marking Directive, 2004/108/EC EMC Directive, and the following Australia and New Zealand Directive: AS/NZS60335.2.2 2002.

PRODUCT INFORMATION

Net weight: 1.23kg

This product is protected by the following intellectual property rights:

PATENTS/APPLICATIONS

CA 2544609; JP 2007-508934; US 2007-0079579; AU 2004294771; AU 2002226556; CA 2,439,250; EP 1370172; JP 4002185; US 6991666; AU 2002225207; EP 1361814; JP 3860541; US 7018439; AU 2001240894; EP 1268076; JP 2003-528704; US 6,835,222; AU 2002-225232; EP 1361815; JP 3940082; US 6,974,488; EP 1748848; JP 2007-534377; US 2007-0175189; WO 2005/110608; WO 2008/009884; WO 2008/009891; WO 2008/015377; WO 2008/015378; WO 2008/009886; WO 2008/009888; WO 2008/009883; GB 2440515; GB 2440514; GB 2440126; GB 2440109; GB 2440107.

DESIGNS/DESIGN APPLICATIONS:

GB 3025398; GB 3025399; GB 3025400; GB 3025401; GB 3025402; GB 3025403; GB 3025404; EU 651849.
Equivalent patents, registered designs and applications exist in other countries.

IMPORTANT!

WASH FILTER



Wash your filter with cold water regularly or as required.

Register for a filter wash reminder by email (Australia only);
customercare@dyson.com.au



Dyson Customer Care

If you have a question about your Dyson handheld vacuum, call the Dyson Customer Care Helpline with your serial number and details of where and when you bought the Dyson handheld vacuum, or contact us via the Dyson website. The serial number can be found on the main body of the Dyson handheld vacuum behind the filter.

AU Dyson Customer Care
customercare@dyson.com.au
1800 239 766
Dyson Appliances (Aust) Pty Ltd.,
PO Box 2835,
Taren Point, NSW 2229,
Australia
www.dyson.com.au

NZ Dyson Customer Care
dyson@averyrobinson.co.nz
0800 397 667
Avery Robinson Ltd.,
Unit F, 151D Marua Road,
Ellerslie, Auckland 1051,
New Zealand
www.dyson.co.nz



QUESTIONNAIRE

Please take a few moments to answer our questions.
They will help us develop new products for the future.

- This handheld cleaner is...
 - My first handheld cleaner
 - A replacement handheld cleaner
 - An additional handheld cleaner
- Which brand of cleaner are you replacing or adding to?

<input type="checkbox"/> Dyson	<input type="checkbox"/> Electrolux
<input type="checkbox"/> Hoover	<input type="checkbox"/> LG
<input type="checkbox"/> Miele	<input type="checkbox"/> Panasonic
<input type="checkbox"/> Samsung	<input type="checkbox"/> Nilfisk
<input type="checkbox"/> Vax	<input type="checkbox"/> Kambrook
<input type="checkbox"/> Volta	<input type="checkbox"/> Wertheim
<input type="checkbox"/> Other, please specify	
- Why did you choose to buy a Dyson handheld cleaner?
(Please rank in order, 1-5. 1 being the most important).
 - Dyson reputation
 - Good for pet hair pick-up
 - Performs consistently well
 - No loss of suction
 - Previous experience of Dyson
 - Features
 - HEPA filtration
 - Price/special offer
 - Wanted a bagless handheld
 - Compact and easy to store
 - Store staff recommendation
 - Picks up more dust than others
 - Latest model/technology
 - Reliability/quality
 - Friend/family recommendation
 - Other
- Where did you first hear about the Dyson model you bought?
 - From friends and family
 - Saw it on the internet
 - From a TV/magazine advert
 - Saw it in a store catalogue
 - Saw it in a store
 - Recommended by salesperson
- Do you own a Dyson handheld?
 - Yes
 - No
- What is your average household income?
 - Less than \$45,000
 - Between \$45,000 – \$74,000
 - Between \$75,000 – \$100,000
 - Over \$100,000
- Do you have any household pets?
 - Dog
 - Cat
 - None
 - Other
- Does anyone in your household suffer from any of the following?
 - Asthma
 - Allergies
 - None
- To which age group do you belong?

<input type="checkbox"/> 16 – 24	<input type="checkbox"/> 25 – 34
<input type="checkbox"/> 35 – 44	<input type="checkbox"/> 45 – 54
<input type="checkbox"/> 55 – 64	<input type="checkbox"/> 65+
- Would you recommend a Dyson handheld cleaner to your family and friends?
 - Yes
 - No
- Do you have children?

<input type="checkbox"/> Pre-school	<input type="checkbox"/> Aged 5-17 years
<input type="checkbox"/> Aged +17 years	<input type="checkbox"/> Children no longer at home
<input type="checkbox"/> Pregnant	<input type="checkbox"/> No children
- Which best describes your house?
(Tick one from each column).

<input type="checkbox"/> Own house	<input type="checkbox"/> Up to 2 beds
<input type="checkbox"/> Rented house	<input type="checkbox"/> 3-4 beds
<input type="checkbox"/> Own apartment/villa	<input type="checkbox"/> More than 4 beds
<input type="checkbox"/> Rented apartment/villa	
<input type="checkbox"/> Live with parents	
<input type="checkbox"/> Share accommodation	

THANK YOU FOR YOUR TIME



Date of purchase / / Store of purchase

Serial number

Did you purchase an extended warranty? Yes No

If yes, for what additional period? 1 year 2 years 3 years

Title Surname

First name

Address

Postcode Country of purchase Australia New Zealand

e-mail

Telephone Mobile

As a Dyson owner, you can hear about Dyson inventions and ideas before anyone else. If it's okay to contact you, please let us know how we may do this.

By mail Yes No By email Yes No

By phone Yes No By text message Yes No

Privacy Act
 Dyson may use this information for future marketing and research purposes (including sending commercial electronic messages) and may disclose it to third parties for the purposes of providing the services you have requested or to our business partners or professional advisers. If you wish to access your personal information or see our full privacy policy, please contact us at customercare@dyson.com.au
 If you do not wish to receive marketing information by these methods from Dyson please tick this box.

3 EASY WAYS TO REGISTER YOUR 2 YEAR GUARANTEE



REGISTER ONLINE

Visit our website to register your full parts and labour guarantee online (Australia only).

www.dyson.com.au/register



REGISTER BY PHONE

Call our dedicated Helpline.

AU 1800 239 766
NZ 0800 397 667
SG 7000 435 7546
ID 021 707 39766



REGISTER BY MAIL

Complete and return the form to Dyson in the envelope supplied.

