

HO904600TX-BLACK/
HO914600TX-WHITE/
HO924600TX-ESPRESSO
"LANGSTON" DESK
Assembly Instruction

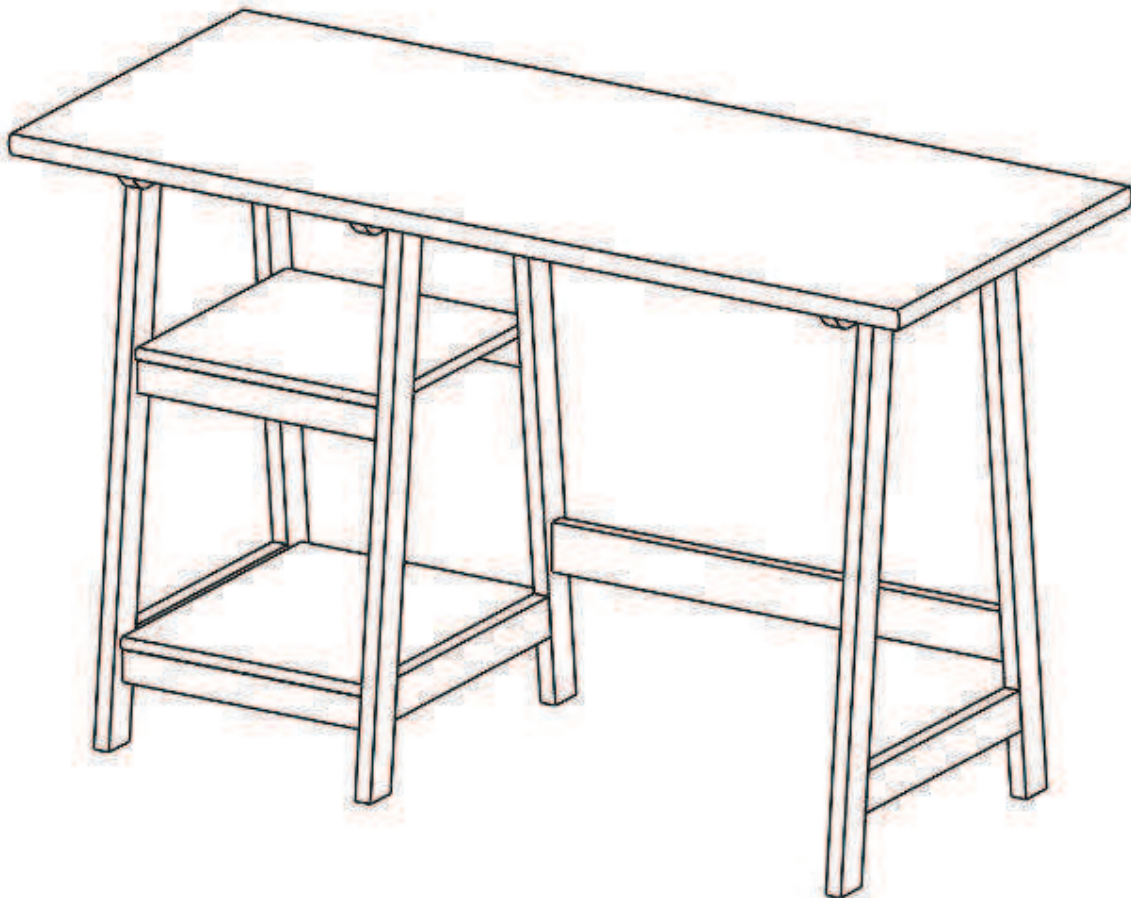

For assistance with assembly contact:
Southern Enterprises Inc.
Customer Service 1-800-633-5096
service@seidal.com
www.seidal.com

Max top load 40 lb.



HO904600TX-BLACK



HO914600TX-WHITE/HO924600TX-ESPRESSO

"LANGSTON" DESK

Parts List

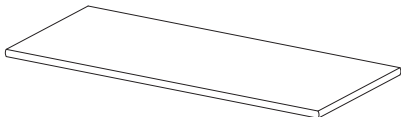
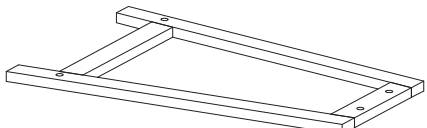
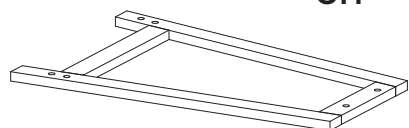
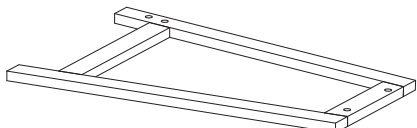
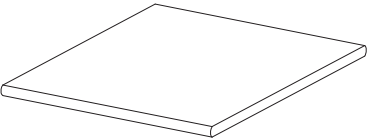
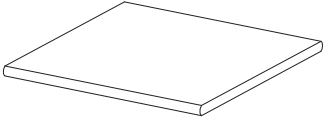
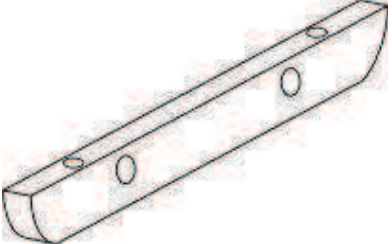
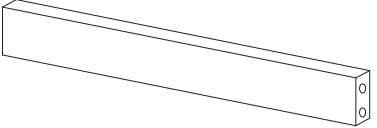
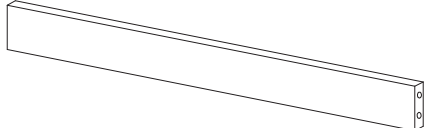
Please review all parts and hardware before disposing of any packaging.
Call Customer Service if missing hardware. Do not return to store/retailer.
Using a screw that is too long will cause damage. Before beginning assembly,
separate each type of screw. Carefully study the screw diagrams below. You may
receive extra hardware with your unit.

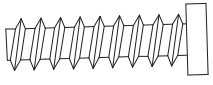
<p>A</p> <p>Quantity Of 1</p>  <p>Wood Top</p>	<p>B</p> <p>Quantity Of 1</p>  <p>Left Side Panel</p>	<p>C</p> <p>Quantity Of 1</p>  <p>Central panel</p>
<p>D</p> <p>Quantity Of 1</p>  <p>Right Side panel</p>	<p>E</p> <p>Quantity Of 1</p>  <p>Second Shelf</p>	<p>F</p> <p>Quantity Of 1</p>  <p>Bottom Shelf</p>
<p>G</p> <p>Quantity Of 3</p>  <p>Top Stretcher</p>	<p>H</p> <p>Quantity Of 4</p>  <p>Short Stretcher</p>	<p>I</p> <p>Quantity Of 1</p>  <p>Long Stretcher</p>

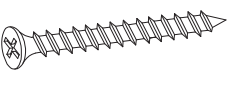
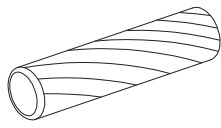
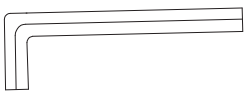
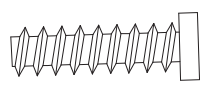
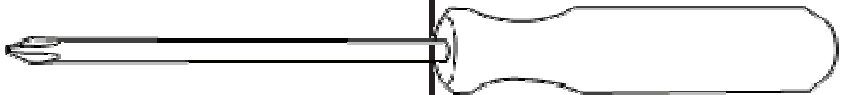
<p>1</p> <p>Quantity Of 10</p>  <p>Bolts 1/4"x 45mm</p>	<p>2</p> <p>Quantity Of 10</p>  <p>Barrel Nuts 1/4"</p>	<p>3</p> <p>Quantity Of 8</p>  <p>Screw 4 x 32mm</p>
<p>4</p> <p>Quantity Of 20</p>  <p>Dowel 8 x30 mm</p>	<p>5</p> <p>Quantity Of 1</p>  <p>Wrench 1/4"</p>	<p>6</p> <p>Quantity Of 12</p>  <p>Bolts 1/4" x 32mm</p>
<p>Care and Cleaning Instructions: Before using, wipe with a clean, dry cloth. Periodically apply furniture wax to renew The finish. Avoid rubbing or scratching the surface with rough or abrasive objects.</p>		<p>For replacement parts or questions, please call Customer Service at 1-800-633-5096. Do not return product to store. Please call manufacturer for assistance, questions or parts.</p>
<p>Assembly Tool Required No.2 phillips screw diver</p>		

HO904600TX-BLACK/
HO914600TX-WHITE/HO924600TX-ESPRESSO
"LANGSTON" DESK
Assembly Instruction

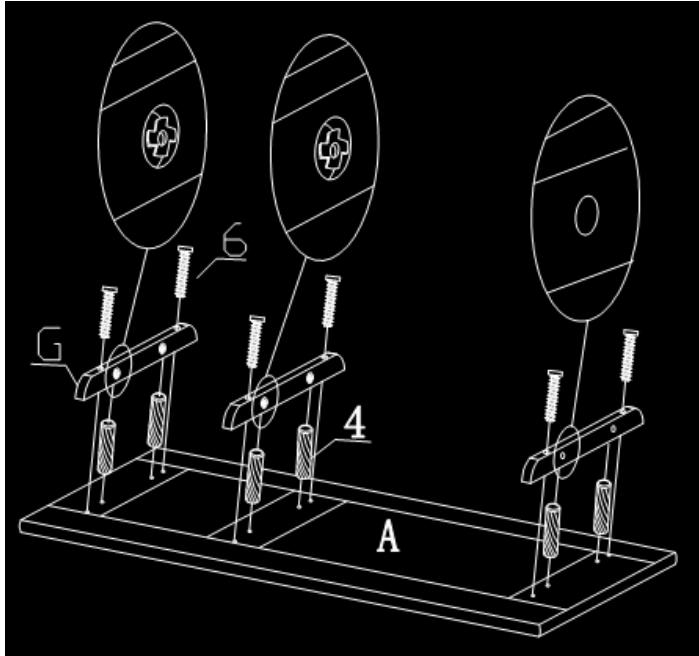

Step 1: Put all parts on a soft surface to prevent scratches ,

Attach top stretcher (G) to wood top (A) by using bolts (6) and dowel (4) as shown.

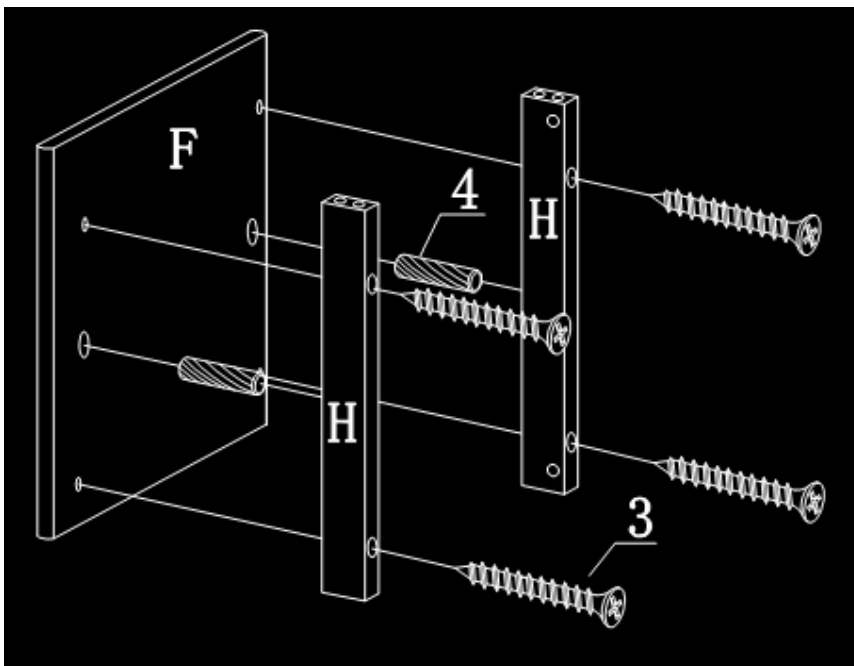

Step 2: Attach short stretcher (H) to top shelf (F) by using screw (3) and dowel (4) as shown.

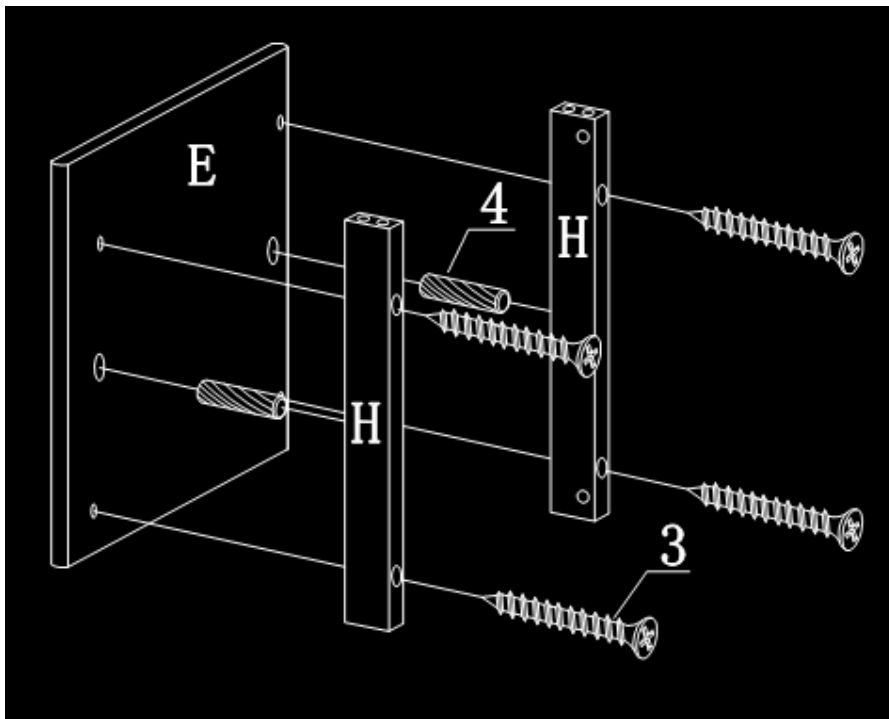

Step 3: Attach short stretcher (H) to bottom shelf (E) by using screw (3) and dowel (4) as shown.

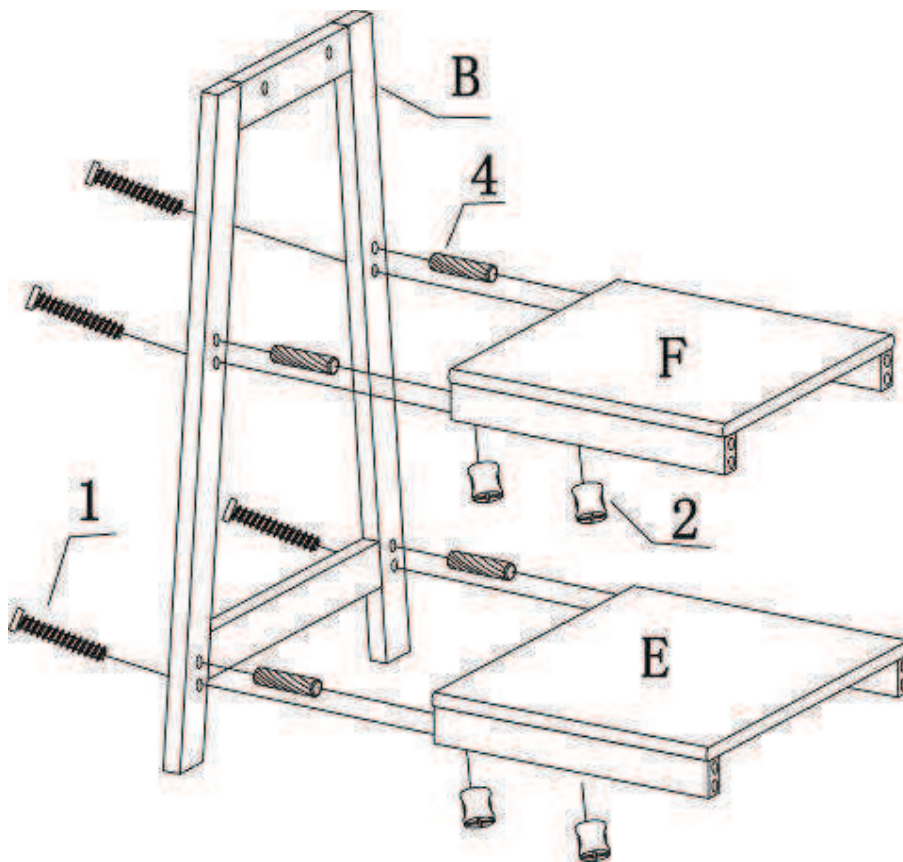

Step 4: Insert barrel nut (2) into short stretcher (H) and keep the hole of barrel nut (2) to be horizontal when assembly.

Then attach left side panel (B) to shelves (E) & (F) by using bolts (1), dowel (4) and barrel nut (2) as shown.

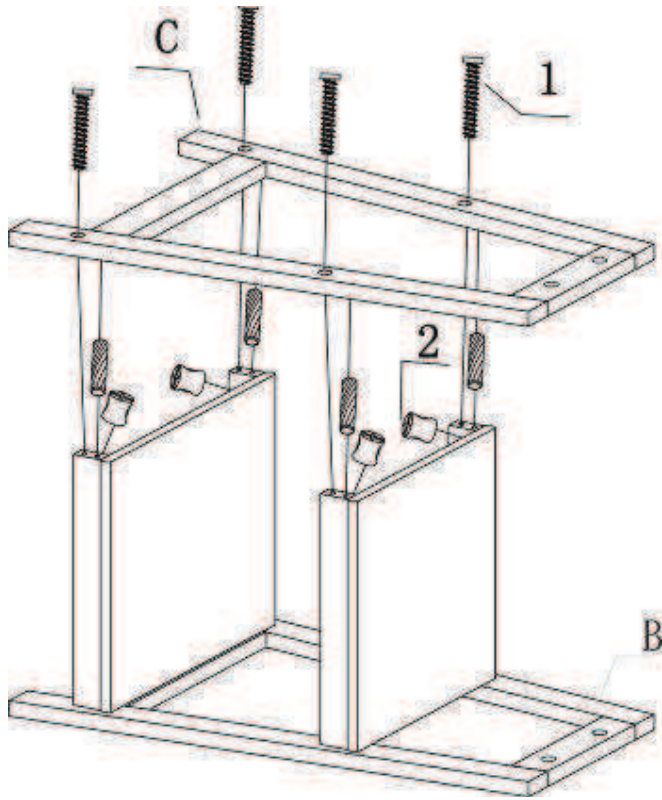

Step 5: Repeat same procedure as Step 4.

Attach central panel (C) to shelves (E) & (F) by using bolts (1), dowel (4) and barrel nut (2) as shown.

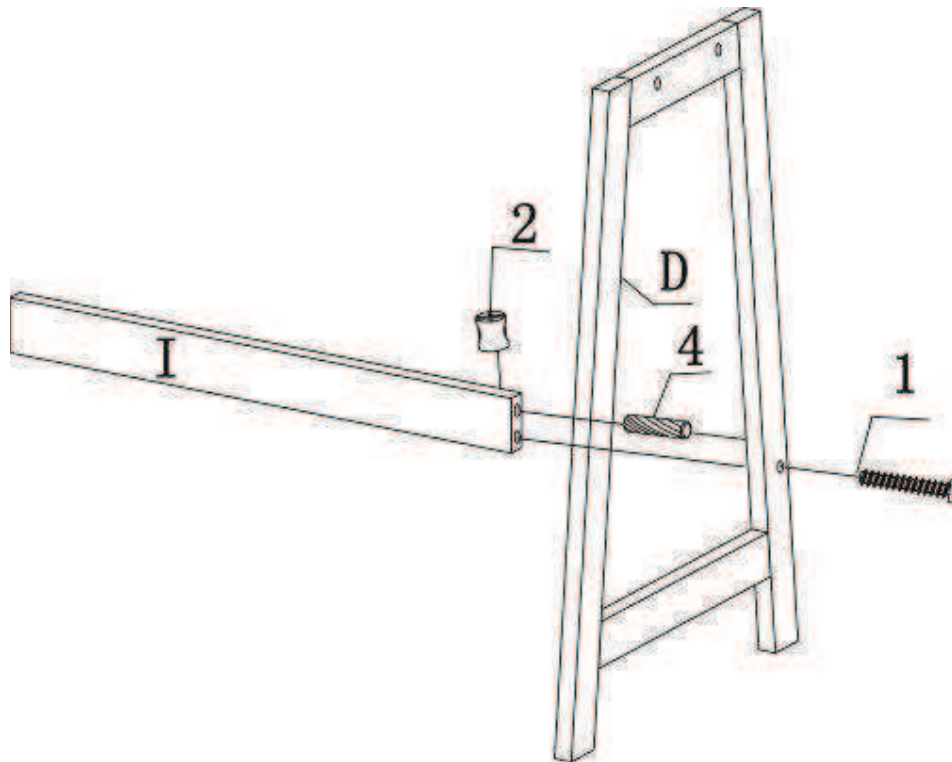

Step 6: Insert barrel nut (2) into long stretcher (I) and keep the hole of barrel nut (2) to be horizontal when assembly.

Attach long stretcher (I) to right side panel (D) by using bolt (1), dowel (4) and barrel nut (2) as shown.

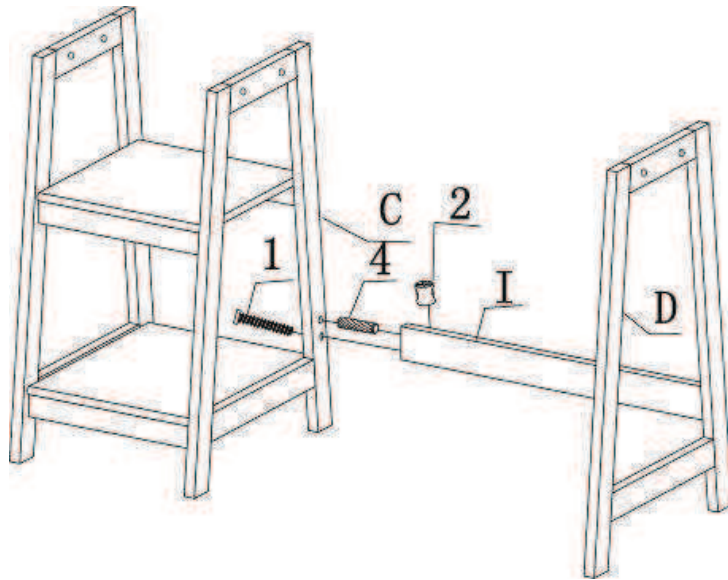

Step 7: Repeat same procedure as Step 6.

Attach long stretcher (I) to central panel (C) by using bolt (1), dowel (4) and barrel nut (2) as shown.

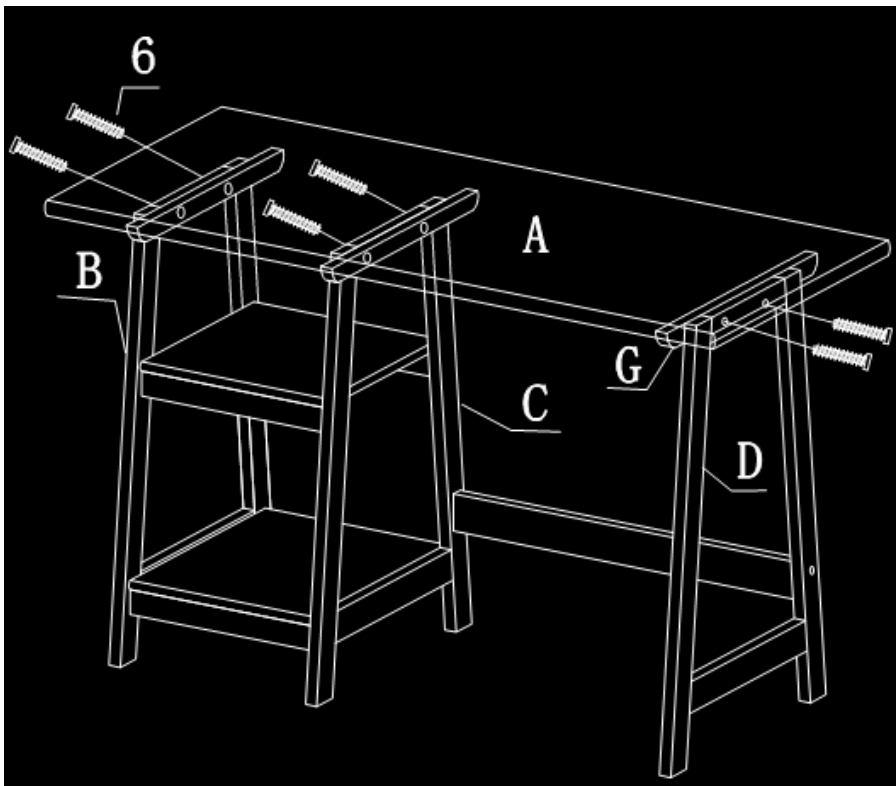

Step 8: Attach wood top (A) to panels (B), (C), (D) by using bolt (6) as shown.

Then your table is ready to use.

We'd love to hear from you! Email us photos of our products in your home at sei@seidal.com and we might feature it on our site or use it to model one of our inspirational photos.

“PARTS WILL BE SENT IF AVAILABLE FROM SEI” “THIS IS NOT A WARRANTY”

Parts Replacement Form

Customer Information

Name _____

Address _____

City/State/Zip Code _____

Phone Number _____

Please indicate where you purchased this item: Store/ Website/ Catalog

Please indicate color/size/style number:

Style No

Parts Letter

Parts Description

Quantity Needed

Please count, identify and compare parts and hardware list to be sure all parts are present. It may help to divide parts and label them to correspond with part list. Extra hardware may be included. If any items are missing, **please contact Southern Enterprises at 800-633-5096 or in Dallas (972) 869-0111/ 9am – 4pm Mon-Fri Central time if you have product issues with your purchase. Please ask for a customer service representative for issues involving damages or replacement parts. Please ask for a technical assistance representative for any issues with product assembly and product construction. Please contact the retailer that you purchased from for returns.**

Missing or damaged hardware and/ or parts will be replaced free of charge. **We do not sell parts. We do not recommend modifying product(s) and we are not responsible for any damages due to product modification(s).**

If this product has not been purchased from our retail affiliates (within 9 months), we are under no obligation to provide parts or replacements merchandise. Parts will not be available for items arriving fully assembled.



Customer Service 1-800-633-5096

service@seidal.com

Southern Enterprises, Inc.

600 Freeport Parkway, Suite 200

Coppell, Texas 75019